

# Caterpillar Performance Handbook

# 41



# CONTENTS

	Page
Preface .....	4
Environment and Sustainability .....	4
Operator and Machine Protection .....	5
Operator Training .....	5
Machine Modifications .....	7
Equipment Options .....	7
Machine Protection .....	7
Fire Prevention .....	7
Safety Regulations .....	8
Sound Suppression .....	8
Replacement Parts Warning .....	8
Nomenclature .....	9

<b>TRACK-TYPE TRACTORS</b>	<b>1</b>
<b>MOTOR GRADERS</b>	<b>2</b>
<b>SKID STEER LOADERS • MULTI TERRAIN LOADERS • COMPACT TRACK LOADERS</b>	<b>3</b>
<b>EXCAVATORS</b>	<b>4</b>
<b>BACKHOE LOADERS</b>	<b>5</b>
<b>FOREST PRODUCTS</b>	<b>6</b>
<b>PIPELAYERS</b>	<b>7</b>
<b>WHEEL TRACTOR-SCRAPERS • TOWED SCRAPERS</b>	<b>8</b>
<b>CONSTRUCTION &amp; MINING TRUCKS</b>	<b>9</b>
<b>ARTICULATED TRUCKS</b>	<b>10</b>
<b>WHEEL DOZERS • SOIL COMPACTORS</b>	<b>11</b>
<b>WHEEL LOADERS • INTEGRATED TOOLCARRIERS</b>	<b>12</b>
<b>TRACK LOADERS</b>	<b>13</b>
<b>TELESCOPIC HANDLERS</b>	<b>14</b>
<b>PAVING PRODUCTS</b>	<b>15</b>
<b>UNDERGROUND MINING EQUIPMENT</b>	<b>16</b>
<b>HYDROMECHANICAL WORK TOOLS</b>	<b>17</b>
<b>ENGINES</b>	<b>18</b>

# CATERPILLAR PERFORMANCE HANDBOOK

a publication by Caterpillar Inc., Peoria, Illinois, U.S.A.

JANUARY 2011

**To be removed from the Caterpillar Performance Handbook subscription list, to change your mailing address, or to change the quantity of books you receive, please call 309-266-0942 or 800-566-7782 (Option 3) or email Media Logistics Services at [Media\\_Logistics@cat.com](mailto:Media_Logistics@cat.com).**

Performance information in this booklet is intended for estimating purposes only. Because of the many variables peculiar to individual jobs (including material characteristics, operator efficiency, underfoot conditions, altitude, etc.), neither Caterpillar Inc. nor its dealers warrant that the machines described will perform as estimated.

**NOTE: Always refer to the appropriate Operation and Maintenance Manual for specific product information.**

Materials and specifications are subject to change without notice.

CAT, CATERPILLAR, SAFETY.CAT.COM, their respective logos, "Caterpillar Yellow" and the "Power Edge" trade dress, as well as corporate and product identity used herein, are trademarks of Caterpillar and may not be used without permission.

<b>FORMER MODELS</b>	<b>19</b>
<b>OWNING &amp; OPERATING COSTS</b>	<b>20</b>
<b>TIRES</b>	<b>21</b>
<b>MINING AND EARTHMOVING</b>	<b>22</b>
<b>STOCKPILE COAL HANDLING</b>	<b>23</b>
<b>LAND CLEARING</b>	<b>24</b>
<b>WASTE HANDLING</b>	<b>25</b>
<b>TECHNOLOGY PRODUCTS</b>	<b>26</b>
<b>TABLES</b>	<b>27</b>

# PREFACE

Machine performance must ultimately be measured in unit cost of material moved, a measure that includes both production and costs. Factors bearing directly on productivity include such things as weight to horsepower ratio, capacity, type of transmission, speeds and operating costs. The Performance Handbook considers these factors in detail. There are other less direct machine performance factors for which no tables, charts or graphs are possible. Serviceability, parts availability and operator convenience are examples. In comparing machine performance, all factors should be considered. This Handbook is intended as an aid which, when coupled with experience and a good knowledge of local conditions, can assist in estimating true machine performance.

Many sections of the Handbook include tables or curves showing cycle times or hourly production figures for Cat® machines under certain conditions. Statements of conditions always accompany or precede the curves or tables. Before using any performance information in this Handbook, a complete understanding of the qualifying conditions is essential. The data is based on field testing, computer analysis, laboratory research and experience; and every effort has been made to assure their correctness.

However, all such data is based upon 100% efficiency in operation — a status which cannot be achieved continuously even under ideal conditions. Thus, in using such performance and production data, it is necessary to correct the results indicated in the handbook tables by appropriate factors. This allows for the anticipated actual job efficiency, operator efficiency, material characteristics, haul road conditions, altitude and other factors which may reduce performance or production on a particular job.

Methods for estimating machine owning and operating costs vary widely, depending on locality, industry practices, owner preferences and other factors. One method is suggested in the Handbook section on Owning and Operating Costs. When used with good judgment, it has provided reasonably accurate estimates in the past. Included in the Owning and Operating Section are guidelines, based on working conditions, to assist in estimating consumption of fuel and lubricants, tire life and repair costs for Cat machines. However, what one Handbook user regards as “excellent” conditions, another may consider “severe” or “average”, depending on his own experience and basis of comparison. Therefore, these guidelines should be considered only approximations.

Caterpillar Inc. has made every effort to assure that the information contained in this Handbook is accurate and is a fair statement of the results to be achieved in the circumstances indicated. However, because of the many variables involved in estimating the production or performance of earthmoving machinery, their consumption of fuel and lubricants, tire life and repair costs, and the possibility of inadvertent errors or omissions in assembling this data, Caterpillar cannot and does not imply that all data in this book are complete nor that this level of performance will be achieved on a given job.

Specifications shown in this Handbook were current at time of printing. However, due to Caterpillar's many machine improvement programs, specifications and materials may change without notice. For current specifications relating to a machine's performance, please refer to the most recent Cat product specification sheet.

**Caterpillar Inc.**

## ENVIRONMENT AND SUSTAINABILITY

Caterpillar supports environmental responsibility through sustainable development. Our products and services are intended to support sustainable development of global resources and they will meet or exceed applicable regulations and standards wherever they are initially sold. We establish and adhere to environmentally sound policies and practices in product design, engineering, and manufacturing.

We educate and encourage our customers to use the products they purchase from us in environmentally responsible ways. We take effective steps to continually increase the natural resources efficiency and cleanliness of our facilities. When available, the various product groups have included relevant sustainability data with their content updates for inclusion in the Performance Handbook.

# OPERATOR AND MACHINE PROTECTION

A well trained operator, working under suitable conditions, utilizing a modern, properly-equipped machine provides a machine-operator team capable of giving maximum production. These factors, along with appropriate job site rules and communication procedures, are essential to coordinate people and machines working together.

Appropriately protected and maintained machines are less likely to suffer premature component failure or damage, and give operators the confidence and assurance they need to carry out their work. Furthermore, training is not complete until the operator reads, understands and agrees to follow the instructions provided in the Operation and Maintenance Manual included with every Cat machine.

Employers have a duty to provide a safe work place for their employees. The purchaser of a Cat machine has a duty to review his/her particular application and job site for the machine to identify potential hazards inherent to that application or job site. Based on the results of this hazard analysis, the appropriate operator and machine protection configuration can be determined.

Caterpillar designs, builds, and tests its products to ensure the safety of operators, maintenance persons, service persons, and bystanders. That means people in, on and around Cat products. Caterpillar provides as standard equipment the appropriate operator and machine protection for most applications. However, particular applications, including the use of some Work Tools, may require additional operator and/or machine protection. Caterpillar offers related options for most such applications. However, there may be very special applications where the Cat dealer or the Purchaser may want to fabricate, or request Caterpillar to provide, custom or special guarding. Your Cat dealer can help you with this hazard analysis and guarding configuration process.

## I. Operator Training and Protection Practices

*Remember that any kind of machine or mechanical device can be hazardous if not kept in good condition, or if operated by careless or improperly trained operators, or if operated in an irresponsible manner.*

Listed below are some recommended basic steps that can be broadly applied to most work environments:

- Train operators for the job they are assigned to do. The length and type of training must comply with governmental and local regulations wherever they apply. As an example, machine operators in mining activities must be trained in accordance with Mine Safety and Health Administration (MSHA) regulations. Where specific regulations do not apply, no operator should be assigned to a job until he or she meets the following minimum requirements:
  - Completes proper training to operate the assigned machine and understands that seat belts must be worn whenever seated in operator's compartment. **SEAT BELTS SAVE LIVES!**
  - Reads and understands the Operation & Maintenance manual for that machine, and knows that a copy of that manual is stored in the operator's compartment.
  - Reads and understands the AEM (Association of Equipment Manufacturers), or any other furnished manual related to rules for safe machine operation and identification of hazards. For example, that includes the Work Tool Operation and Maintenance Manual if a Cat Work Tool is involved in the given application.
  - Has appropriate personal safety equipment and knows how to use it. This includes such things as hard hat, gloves, safety glasses, hearing protection, high-visibility vest, and safety shoes.
  - Knows what the job requirements are, what other machines are working in the area, and is aware of any hazardous conditions that may arise.

- Be sure operators are alert and in proper physical and mental condition to perform their work assignments safely. No machine should be operated by a person who is drowsy, under the affect of medicines or drugs, suffers blackouts, or is suffering from any physical or mental distraction that could contribute to unsafe operation.
- Maintain proper job conditions and working procedures. Check the job for possible hazards, both above and below ground level. Look for all possible sources of danger to the operator and others in the area. When operating in hazardous conditions the door and windows must always be closed. Pay particular attention to conditions which may be hazardous or near the operating limits of the machine: e.g., side slopes, steep grades, potential overloads, etc. Examine the work site for restricted traffic patterns, obstructed views, congestion, underground power or gas lines, etc. If the machine is equipped with a Quick Coupler, always make sure the Work Tool is properly attached by conducting an attachment test as directed in the Quick Coupler Operation and Maintenance Manual. Hazardous work conditions should be corrected wherever possible and adequate warnings should be posted when applicable.
- Provide the correct machine to handle the job and equip it properly for the job to provide the necessary operator protection. Check for compliance with all applicable governmental and local regulations. It is the legal responsibility of the machine owner or employer to see that his equipment complies with, and is operated in accordance with, all such requirements.
- Make sure the machine is properly maintained. The operator at the beginning of each shift should perform a walk-around inspection before the machine is placed in operation. This process is described in the machine and Work Tool Operation and Maintenance Manual. If this inspection reveals any problems that could affect safety, the machine or Work Tool must not be operated until these problems are corrected. Some examples include:
  - Loose, bent or missing grab irons, railings or steps;
  - Worn, cut or missing seat belts (any seat belt over three (3) years old must be replaced regardless of condition);
  - Damaged windows in the operator's compartment;
  - Worn, rubbing or abraded electrical insulation and hydraulic hoses;
  - Material or unwanted debris accumulation;
  - Incompatibility of the component attachments (Quick Couplers);
  - Hydraulic leaks that could impair the lock/secure feature of a Quick Coupler or other securing devices;
  - Any fluid leaks; and
  - Missing or damaged guards.
- Know the limits of your machine and equipment. With certain Work Tool combinations, including Quick Couplers, the Work Tool can hit the cab or the machine. Always check for interference limits when first operating.
- It is the machine owner's or employer's responsibility to ensure the machine is properly maintained. Your Cat dealer will be glad to assist you in selecting and equipping the machine best suited for your job and in providing maintenance for your machines.

## II. Machine Modifications

Modifications must not be made to the machine that:

- Interfere with operator visibility;
- Interfere with ingress or egress from the machine;
- Exceed the rated payload or gross combination weight of the machine resulting in overloading the braking and/or steering system or the roll-over protective structure (ROPS) capacity rating (shown on a plate affixed to the ROPS); or
- Place objects in the cab that intrude into the operator's space or that are not firmly fixed into place.
- Are not authorized by Caterpillar.

## III. Operator-related Equipment Options

Each job presents unique conditions that must be taken into account. Consider direct dangers to the operator as well as all possible sources of distraction that could reduce operator efficiency and increase the chances of costly and dangerous mistakes. Climate-controlled, sound-suppressed cabs, and special exterior lighting are options available from Caterpillar that can address requirements of special working environments.

“Flexible” machines include hydraulic excavators (track-type, wheel-type, and compact), skid-steer loaders, backhoe loaders and integrated tool-carriers can utilize interchangeable “Work Tools” to accomplish specific tasks. Work Tools or any tool used in hazardous applications like demolition, quarry, logging, stump grinding, scrap handling, milling, and scaling, can create a need for special operator guarding. When flying debris from impact, cutting, shearing or sweeping attachments is present, additional protective devices such as a front screen, Falling Object Guarding System (FOGS, includes top & front guarding), thick polycarbonate windshields or a combination of these is recommended by Caterpillar. The failure to provide proper operator/machine guarding in some of these applications can lead to machine damage, personal injury or death. Contact your Cat dealer for operator guarding options on your machine.

## IV. Machine Protection

Check the job for unusually demanding conditions that could cause premature failure or excessive wear of machine components. Additional protective devices such as heavy-duty radiator guards, crankcase guards, engine enclosures, track roller guards and/or brake shields may be needed. Also, consider the use of anti-vandalism devices, such as cap locks and instrument panel guards. The failure to provide proper guarding in some of these applications can lead to machine damage, personal injury or death. Contact your Cat dealer for machine-protection and vandalism-prevention options for your machine.

## V. Fire Prevention

***Remember that most fluids on your machine are flammable!***

To minimize the risk of fire, Caterpillar recommends following these basic steps:

- Always perform the Walk-Around Inspection described in Part I. It can identify many of the fire hazards described below.
- Remove trash (leaves, twigs, papers, etc.) that may accumulate in the engine compartment or around other hot parts on the product.
- Do not operate a machine if leakage of flammable fluids is noticed. Repair leaks before resuming machine operation. Most fluids used in Cat machines should be considered flammable.
- Keep access doors to major machine compartments in working order to permit the use of fire fighting equipment, should a fire occur.
- Avoid attaching electrical wiring to hoses and tubes that contain flammable or combustible fluids. Hydraulic hoses can move during machine operation and abrade wires and other hoses if improperly secured.
- Replace any rubbing, damaged, frayed, kinked or leaking hydraulic hoses or fittings. Use genuine Cat parts or their equivalent, including both pressure and temperature limit capabilities.
- Follow safe fueling practices as described in Cat Operation and Maintenance Manuals, AEM Safety Manuals, and local regulations. Never store flammable fluids in the machine operator's compartment, nor smoke while fueling the machine.
- As an additional safety measure, keep a fire extinguisher on the machine in a location as specified in the Operation and Maintenance Manual.
- Consider installation of an after-market fire-suppression system (FSS) on the equipment if the application and working conditions warrant it.



## VI. Safety Regulations

Regulations vary from country to country and often within country. Your Cat dealer can assist you in properly equipping your machine to meet applicable requirements. **Note: The general summaries given below are not substitutes for Owners or Employers reading and being familiar with the appropriate local laws.**

### (a) United States (US)

With a few exceptions, all machine operations in the United States are covered by federal and/or state regulations. If the machine is used in mining activities, the regulations are administered by the Mine Safety and Health Administration (MSHA). Other activities, including construction, are under regulations administered by the Occupational Safety and Health Administration (OSHA). These agencies require employers to provide a safe working environment for employees. Caterpillar has the same objective.

OSHA and MSHA have adopted criteria for ROPS, Falling Object Protective Structures (FOPS), seat belts, warning horns, back-up alarms, operator sound levels, steering systems, and braking systems. Additional operator's compartment protection may be required for machines engaged in logging, demolition and other special applications.

### (b) European Union (EU)

The EU Machinery Safety Directive applies to Cat machines and most work tools. It requires that the "CE mark" be applied to the product and that a manufacturer's declaration be provided. The "CE mark" indicates that safety issues have been addressed by applying the appropriate safety standards in the design and manufacture of the machine. The objective of the Safety Directive is to protect operators, spectators and maintenance personnel. Caterpillar fully supports this objective. This is especially true if a machine is not equipped with a closed cab. For example if the machine has no cab, or is being operated with the doors or windows opened.

## VII. Sound Suppression

Different marketing areas have different noise emission requirements. Noise regulations usually specify limits for operators and spectators.

### (a) United States

OSHA and MSHA noise-control regulations set permissible noise-exposure limits for machine operators and employees. Operator protection from machine noise can be achieved by use of factory-built cabs as offered in the Caterpillar Price List. These cabs, when properly maintained and operated with the doors and windows closed, reduce the operator sound level for an eight-hour operating period to meet the OSHA and MSHA noise-exposure limits in effect at the date of manufacture. Variables that may be encountered on the job site, such as other nearby noise sources or noise-reflecting surfaces, may reduce the allowable work hours. If this occurs, ear protective devices may be required. This is especially true if a machine is not equipped with a closed cab. For example if the machine has no cab, or is being operated with the doors or windows opened.

### (b) European Union

Operator sound-exposure requirements for machines in Europe are very similar to the OSHA and MSHA regulations mentioned above. In addition to operator sound-exposure requirements, most types of Cat machines are subject to European Commission regulations for exterior sound levels. Caterpillar ensures its products sold in the EU comply with the applicable noise regulations.

## VIII. Replacement Parts for your Cat Machine

### **WARNING**

When replacement parts are required for this product, Caterpillar recommends using Cat replacement parts or parts with equivalent specifications including, but not limited to, physical dimensions, type, strength and material. Failure to heed this warning can lead to premature failures, product damage, personal injury or death of persons on, or around, the product.

# Nomenclature

## THE CAT PRODUCT LINE

### TRACK-TYPE TRACTORS

Flywheel power 55 to 634 kW (74 to 850 hp)

### \*Waste Handling Arrangements (WHA)

available for sanitary landfill applications



D3K XL  
D3K LGP



D4K XL  
D4K LGP



D5K XL  
D5K LGP



D5N XL  
D5N LGP



D6K XL  
D6K LGP



D6N XL  
D6N LGP



D6G Series 2 XL  
D6G Series 2 LGP



D6R  
D6R XL  
D6R LGP



D6R Series 3\*  
D6R XL Series 3\*  
D6R XW Series 3\*  
D6R LGP Series 3\*  
D6T\*



D7E  
D7E LGP



D7G Series 2



D7R Series 2\*  
D7R XR Series 2\*  
D7R LGP Series 2\*



D8R  
D8T\*  
D8R LGP  
D8T LGP



D9R  
D9T\*



D10T\*



D11T  
D11T CD

### MOTOR GRADERS

Flywheel power 104 to 397 kW (140 to 533 hp)

\*All Wheel Drive.



120K



120M Global  
120M Global  
with AWD\* option



12K



12M Global



140K



140M Global  
140M Global  
with AWD\* option



160K



160M Global  
160M Global  
with AWD\* option



14M Global



16M Global



24M Global

### SKID STEER LOADERS/MULTI TERRAIN LOADERS/COMPACT TRACK LOADERS

Operating Weight 2600 to 4865 kg (5710 to 10,730 lb)



Skid Steer  
216B2  
226B2  
232B2  
242B2  
236B2  
252B2



Skid Steer  
246C  
256C  
262C  
272C



Multi Terrain  
247B2  
257B2



Multi Terrain  
277C  
287C  
297C



Compact Track  
279C/289C  
299C

## HYDRAULIC EXCAVATORS

Operating Weight 1650 to 316 600 kg (3640 to 698,000 lb)

### Track Models



301.6C  
301.8C



302.5C



303C CR  
303.5C CR  
305.5



307C  
307D



308D CR  
308C CR SB



311D LRR



312D  
312D L



313C CR  
313C SR



314C CR  
314C LCR



315D L



319D L  
319D LN



320D  
320D RR  
320D LRR  
320D L  
323D L  
323D LN



321D LCR



324D  
324D L  
324D LN



329D  
329D L  
329D LN



336D  
336D L  
336D LN  
336E



345D  
345D L – FIX  
345D L – VG



365C L



374D



385C  
385C L



390D

### Front Shovels

Operating Weight 74 300 to 318 500 kg (163,803 to 702,000 lb)



385C FS

### Wheel Models



M313D



M315D



M316D



M318D



M322D

## BACKHOE LOADERS

Digging depth 4420 to 6528 mm (14'6" to 21'5")



416E 420E/420E IT



422E 428E



430E/430E IT



432E 442E



434E MECHANICAL  
434E PILOT  
444E



450E

## FOREST PRODUCTS

### Wheel Skidders



525C  
535C  
545C

### Track Skidders



517 Cable  
527 Cable



517 Grapple  
527 Grapple

### Forest Machines



320D FM 325D FM  
324D FM 330D FM

### Wheel Loaders and Integrated Tool Carriers



950H LL 988H LL  
966H LL IT62H LL  
980H LL

### Work Tools

Grapples  
Logging Forks  
Woodchip Dozers  
Scoops  
Rakes

### Track Harvesters



501 532  
501 HD 541  
511 551  
521 552  
522

### Wheel Harvester



550

### Track Feller Bunchers



511 541  
521 551  
522 552  
532

### Wheel Feller Bunchers



553  
563  
573

### Felling Heads

HF 201  
HF 221

### Forwarders



534 544  
564 574  
584/584HD

### Knuckleboom Loaders



519 519SM  
529 519SM/EHC  
559B 569SM  
569 569SM/EHC  
579

## PIPELAYERS

Lifting capacity 18 145 to 91 625 kg (40,000 to 202,000 lb)



PL61



572R Series 2



583T



587R/587T

## WHEEL TRACTOR-SCRAPERS

### Standard Models

Heaped capacity 17 to 26 m<sup>3</sup> (22 to 34 yd<sup>3</sup>)



621G



631G

### Tandem Powered Scrapers

Heaped capacity 17 to 33.6 m<sup>3</sup> (22 to 44 yd<sup>3</sup>)



627G



637G



657G

### Elevating Scrapers

Heaped capacity 17.6 m<sup>3</sup> (23 yd<sup>3</sup>)



623G

### Coal Bowl Scrapers

Heaped capacity 38 to 56 m<sup>3</sup> (50 to 73 yd<sup>3</sup>)



637G



657G

### Push-Pull Scrapers

Heaped capacity 17 to 33.6 m<sup>3</sup> (22 to 44 yd<sup>3</sup>)



627G



637G



657G

## CONSTRUCTION & MINING TRUCKS

### Construction & Mining Trucks

Capacity 37 to 363 metric ton — 41 to 400 U.S. tons

\*OEM Solutions Group non-dumper for special applications available



770  
772



773E  
773F\*  
775F\*



777D  
777F\*



785C  
785D\*



789C



793D  
793F



797F

## ARTICULATED TRUCKS

Capacity 23.6 to 39.5 metric tons (26 to 43.5 U.S. tons)



725



730



730 Ejector



735



740



740 Ejector

## WHEEL DOZERS

Flywheel power 173 to 597 kW (232 to 801 hp)



814F2



824H



834H



844H



854K

## LANDFILL COMPACTORS

Flywheel power 173 to 349 kW (232 to 468 hp)



816F2



826H



836H



815F2



825H

## SOIL COMPACTORS

Flywheel power 173 to 264 kW (232 to 354 hp)

## WHEEL LOADERS & INTEGRATED TOOLCARRIERS

Bucket Capacity (Heaped) 0.6 to 30 m<sup>3</sup> (0.78 to 40 yd<sup>3</sup>)

\* High lift arrangement available.  
† Waste handling arrangement available.



904H



906H



907H



908H



914G/IT14G



924Hz†



924H Pin On\*  
924H Hook On\*†



928Hz†



930H Pin On\*  
930H Hook On\*†



938H\*†  
IT38H†



950H\*†



962H\*†  
IT62H†



966H\*†



972H\*†



980H\*†



988H\*



990H\*



992K



993K\*



994F\*

## TRACK LOADERS

Bucket Capacity (Heaped)\* 1.15 to 3.2 m<sup>3</sup> (1.5 to 4.2 yd<sup>3</sup>)

\*General Purpose Bucket.

†Waste handling arrangement available.



939C



953D†



963D†



973C†



973D†

## TELESCOPIC HANDLERS

### Non-U.S. Versions



TH255



TH406  
TH407  
TH336  
TH337  
TH414  
TH417  
TH514

### U.S. Versions



TH255



TH406  
TH407



TL642  
TL943  
TL1055  
TL1255

## PAVING PRODUCTS\*

\*Paving products starting with BG are Barber Greene products.

### Cold Planers



PM102



PM200 — 2.0 m



PM200 — 2.2 m



PM201

### Reclaimer/Soil Stabilizers

Flywheel power 250-321 kW (335-430 hp)

Cutting width 2438 mm (8'0")



RM300



RM500

### Asphalt Pavers

Paving width 914 to 9754 mm (3 to 32 ft)



AP300



AP500E



AP600D



AP1000D



AP555E



AP655D



AP755



AP1055D



BG500E



BG600D



BG-260D



BG555E



BG655D



BG-2455D

---

## PAVING PRODUCTS (Continued)

### Vibratory and Pneumatic Tire Compactors

#### Single Drum Smooth

Drum width 1270 to 2130 mm (4'2" to 7'0")



CS323C



CS423E



CS433E



CS44



CS533E



CS54



CS56



CS64



CS74



CS76



CS76 XT

#### Single Drum, Padded

Drum width 1270 to 2130 mm (4'2" to 7'0")



CP323C



CP433E



CP44



CP533E



CP54



CP56



CP64



CP74



CP76

#### Double Drum and Combi

Drum width 1000 to 2130 mm (3'3.4" to 7'0")



CB14



CB14 XW



CB14 Full Flush



CB22



CB24



CC24



CB32



CB434D



CB434D XW



CB54



CB54 XW



CB64



CD54

### Pneumatic Tire Asphalt Compactors

Wheel loads 1134 to 5000 kg (2500 to 11,020 lb)



PS150C



PS360C

---

## UNDERGROUND MINING

### Load-Haul-Dump

Bucket sizes 2.4-11.6 m<sup>3</sup> (3.1-15.2 yd<sup>3</sup>)



R1300G II



R1600G



R1700G



R2900G  
R2900G XTRA

### Articulated Trucks

30-55 t (33-61 T) capacity



AD30



AD45B



AD55B

---

## HYDROMECHANICAL WORK TOOLS

### Hydraulic Hammers

H35D S	H115 S
H45D S	H120C S
H55D S	H130 S
H65D S	H140D S
H70/H70 S	H160D S
H90/H90C S	H180D S
H100/H100 S	

### Mobile Scrap and Demolition Shears

S305	S340B
S320B	S365B
S325B	S385B

### Multi-Processors

MP15	MP30
MP20	MP40

### Contractor's Grapples

G107B	G130B
G112B	G145B
G115B	G165B
G120B	G185B
G125B	

### Sorting and Demolition Grapples

G315	G310B
G320	G315B
G330	G320B

### Orange Peel Grapples

GSH15B
GSH20B
GSH22B





# TRACK-TYPE TRACTORS

## Hydraulic Controls

## Bulldozers

## Rippers and Winches

### CONTENTS

#### TRACK-TYPE TRACTORS

Features .....1-1  
 Specifications .....1-3  
 Power Shift Drawbar Pull vs.  
 Ground Speed Curves .....1-17  
 Power Shift Travel Speeds .....1-23  
 Ground Pressures .....1-25  
 Extreme Slope Operation .....1-27

#### HYDRAULIC CONTROLS

Features .....1-29  
 Specifications .....1-30

#### BULLDOZERS

Features .....1-33  
 Summary of Blade Options .....1-34  
 Blade Selection .....1-35  
 General Dimensions (Tractor and Blade) ....1-38  
 SAE Blade Capacity Definition .....1-38  
 Blade Specifications .....1-39  
 Estimating Production Off-the-Job .....1-52  
 Job Condition Correction Factors .....1-56  
 Measuring Production On-the-Job .....1-57  
 Work Tools .....1-57

#### RIPPERS

Features .....1-59  
 Ripper Specification Diagrams  
 Adjustable Parallelogram Ripper .....1-60  
 Radial Ripper .....1-62  
 Fixed Parallelogram Ripper .....1-62  
 Specifications  
 Track-Type Tractors .....1-63  
 Tip Selection .....1-72  
 Estimating Ripping Production .....1-72  
 Seismic Wave Velocity Charts .....1-75  
 Estimated Ripper Production Graphs .....1-80

#### WINCHES

PACCAR Features .....1-83  
 Allied Features .....1-84  
 Physical Specifications .....1-85  
 Operating Specifications .....1-97  
 Waste Handling See Waste  
 Track-Type Tractors .....Handling Section

#### TRACK-TYPE TRACTORS

##### Features:

- **Cat® Diesel Engines** provide the power, high torque rise, reliability and performance you can depend on.
- **HEUI** on D6T increases fuel efficiency, reduces smoke, improves cold starting and enhances diagnostic capabilities.
- **Electronic Unit Injection (EUI)** on D7R Series 2. The Electronic Control Module (ECM) performs much like a mechanical governor, but has no moving parts. The ECM signals the injectors regulating the fuel supply thus controlling engine speed and power. EUI provides: Reduced exhaust smoke, automatic altitude compensation and cold start protection.
- **Mechanical Electronic Unit Injector (MEUI)** on D8T, D9T, D10T and D11T excels in its ability to control injection pressure over the entire engine operating speed range. It combines the technical advancement of an electronic control system with the simplicity of direct mechanically controlled unit fuel injection. These features allow the engine to have complete control over injection timing, duration, and pressure.

- **Common Rail fuel injection system on D6K, D6N and D7E** as well as D3K, D4K and D5K; optimizes performance and fuel consumption, minimizes heat rejection, and lowers emissions.
- **Oil cooled steering clutches and brakes** standard on D9R, D10T and D11T.
- **Finger Tip Controls (FTC)** of transmission, steering clutches and brakes on D10T and D11T.
- **Differential steering** allows infinitely variable turning radius. Standard on the D6N, D6T, D7R Series 2, D7E, D8R and D8T, allows the tractor to make a “power turn” keeping both tracks working for more traction and higher performance.
- **Electronic Hydrostatic Power Train System** on D3K thru D6K allows power turns, stepless speed range, smooth modulation, dynamic hydrostatic braking, superior maneuverability and excellent controllability.
- **Electric Drive Power Train System** on D7E allows stepless speed range, smooth modulation, and excellent efficiency. When coupled with differential steer it provides superior maneuverability with locked-track pivot turn capability and excellent controllability.
- **Combined hand lever steering** located left of operator provides easier operation on D9R.
- **Standard Tractors** designed for heavy dozing and general grading.
- **XL Tractor D6T** offers higher horsepower and longer roller frames for increased finish grading capability, flotation and productivity.
- **Extra Wide (XW) gauge** on D6T length roller frame provides wider shoes for greater flotation and stability for steep slope grading.
- **Sealed and Lubricated Track** reduces pin and bushing wear for lower undercarriage repair costs. Sealed and lubricated track is standard on the D3K, D4K, and D5K while heavy duty track chain is available on D6N, D6T, D7R Series 2 and D7E improves wear life and reduces pin/bore stretching and cracking.
- **SystemOne Undercarriage** extends undercarriage system life, improves reliability, and reduces owning and operating costs. Optional on D6T (all sources), D6K and D6N, optional on D8T and D8R (East Peoria sourced), D3K, D4K, D5K.
- **Elevated sprockets** (not on D6K or D7E) eliminate final drive stress induced by roller frame movement and ground impact loads. Final drives pull chain only. Seals moved up out of dirt, sand and water for longer life. Blade visibility improved because operator sits higher.
- **Resilient mounted bogie undercarriage** on D8R, D8T, D9T, D10T and D11T reduces shock transmitted to tractor. Allows track to conform to rough ground for better traction.
- **Solid mounted undercarriage** standard on D3K through D5K provides stable platform for low impact, and high abrasion applications. Provides optimum finish grading performance.
- **Oscillating undercarriage** on D6K through D7E and optional on the D8R and D8T decreases ground shock to the machine and provides a smoother, more comfortable ride for the operator.
- **Accessible modular design** on D6N XL and up greatly reduces drive train removal and installation time resulting in reduced repair costs.
- **Tag link** on D7R Series 2 and up; L-shaped push arms on D6N, D6T and D7E. Both designs allow closer mounting of dozer blades. This reduces total tractor length, improves maneuverability, balance, blade penetration and pryout.
- **Low ground pressure (LGP)** tractors offer greater flotation in soft, swampy conditions. Available on D3K through D8T.



MODEL	D3K XL		D3K LGP		D4K XL		D4K LGP	
Flywheel Power	55.2 kW	<b>74 hp</b>	55.2 kW	<b>74 hp</b>	62.6 kW	84 hp	62.6 kW	84 hp
Operating Weight*	7795 kg	<b>17,185 lb</b>	8093 kg	<b>17,842 lb</b>	8147 kg	<b>17,961 lb</b>	8501 kg	<b>18,742 lb</b>
Engine Model	<b>C4.4 ACERT™</b>		<b>C4.4 ACERT</b>		<b>C4.4 ACERT</b>		<b>C4.4 ACERT</b>	
Rated Engine RPM	<b>1900</b>		<b>1900</b>		<b>1900</b>		<b>1900</b>	
No. of Cylinders	<b>4</b>		<b>4</b>		<b>4</b>		<b>4</b>	
Bore	105 mm	<b>4.13"</b>	105 mm	<b>4.13"</b>	105 mm	<b>4.13"</b>	105 mm	<b>4.13"</b>
Stroke	127 mm	<b>5.0"</b>	127 mm	<b>5.0"</b>	127 mm	<b>5.0"</b>	127 mm	<b>5.0"</b>
Displacement	4.4 L	<b>269 in³</b>	4.4 L	<b>269 in³</b>	4.4 L	<b>269 in³</b>	4.4 L	<b>269 in³</b>
Track Rollers (Each Side)	<b>6</b>		<b>6</b>		<b>7</b>		<b>7</b>	
Width of Standard Track Shoe	406 mm	<b>16"</b>	635 mm	<b>25"</b>	460 mm	<b>18"</b>	635 mm	<b>25"</b>
Length of Track on Ground	2095 mm	<b>83"</b>	2095 mm	<b>83"</b>	2248 mm	<b>89"</b>	2248 mm	<b>89"</b>
Ground Contact Area (w/Std.Shoe)	17 011 cm²	<b>2637 in²</b>	26 607 cm²	<b>4124 in²</b>	20 682 cm²	<b>3206 in²</b>	28 550 cm²	<b>4425 in²</b>
Track Gauge	1495 mm	<b>59"</b>	1725 mm	<b>68"</b>	1550 mm	<b>61"</b>	1725 mm	<b>68"</b>
GENERAL DIMENSIONS:								
Height (To Top of ROPS)	2763 mm	<b>108.8"</b>	2763 mm	<b>108.8"</b>	2763 mm	<b>108.8"</b>	2763 mm	<b>108.8"</b>
Overall Length (with P blade)	4266 mm	<b>168"</b>	4255 mm	<b>167.6"</b>	4274 mm	<b>168"</b>	4266 mm	<b>168"</b>
(without Blade)	3275 mm	<b>128.9"</b>	3275 mm	<b>128.9"</b>	3275 mm	<b>128.9"</b>	3275 mm	<b>128.9"</b>
Width (w/o Trunnion and Blade — Std. Shoe)	1901 mm	<b>74.8"</b>	2360 mm	<b>92.9"</b>	2010 mm	<b>79.1"</b>	2360 mm	<b>92.9"</b>
Ground Clearance	332 mm	<b>13"</b>	332 mm	<b>13"</b>	332 mm	<b>13"</b>	332 mm	<b>13"</b>
Blade Types and Widths:								
VPAT, Straight	2646 mm	<b>104.1"</b>	3149 mm	<b>124.0"</b>	2782 mm	<b>109.5"</b>	3149 mm	<b>124.0"</b>
VPAT, Angled 25°	2417 mm	<b>95.1"</b>	2874 mm	<b>113"</b>	2542 mm	<b>100.1"</b>	2874 mm	<b>113"</b>
Fuel Tank Refill Capacity	195 L	<b>51.5 U.S. gal</b>	195 L	<b>51.5 U.S. gal</b>	195 L	<b>51.5 U.S. gal</b>	195 L	<b>51.5 U.S. gal</b>

\*Operating weight includes ROPS canopy, operator, lubricants, coolant, full fuel tank, hydraulic controls and fluids, back-up alarm, seat belts, lights, rigid drawbar, front pull device and standard service crankcase guard.



**D5K XL**



**D5K LGP**

**MODEL**

	<b>D5K XL</b>		<b>D5K LGP</b>	
Flywheel Power:				
Hydrostatic	71.6 kW	<b>96 hp</b>	71.6 kW	<b>96 hp</b>
Operating Weight:*				
Hydrostatic	9408 kg	<b>20,741 lb</b>	9683 kg	<b>21,347 lb</b>
Engine Model	<b>C4.4 ACERT</b>		<b>C4.4 ACERT</b>	
Rated Engine RPM	<b>1900</b>		<b>1900</b>	
No. of Cylinders	<b>4</b>		<b>4</b>	
Bore	105 mm	<b>4.13"</b>	105 mm	<b>4.13"</b>
Stroke	127 mm	<b>5.0"</b>	127 mm	<b>5.0"</b>
Displacement	4.4 L	<b>269 in<sup>3</sup></b>	4.4 L	<b>269 in<sup>3</sup></b>
Track Rollers (Each Side)	<b>7</b>		<b>7</b>	
Width of Standard Track Shoe	510 mm	<b>20"</b>	660 mm	<b>26"</b>
Length of Track on Ground	2310 mm	<b>91"</b>	2310 mm	<b>91"</b>
Ground Contact Area (w/Std. Shoe)	23 562 cm <sup>2</sup>	<b>3652 in<sup>2</sup></b>	30 492 cm <sup>2</sup>	<b>4726 in<sup>2</sup></b>
Track Gauge	1600 mm	<b>63"</b>	1750 mm	<b>69"</b>
<b>GENERAL DIMENSIONS:</b>				
Height (To Top of ROPS Canopy)	2769 mm	<b>109.0"</b>	2769 mm	<b>109.0"</b>
Height (To Top of ROPS Cab)	2769 mm	<b>109.0"</b>	2769 mm	<b>109.0"</b>
Overall Length (with P Blade)	4321 mm	<b>170.1"</b>	4294 mm	<b>169.1"</b>
(without Blade)	3199 mm	<b>125.9"</b>	3265 mm	<b>128.5"</b>
Width (w/o Trunnion and Blade — Std. Shoe)	2110 mm	<b>83.1"</b>	2410 mm	<b>94.9"</b>
Ground Clearance	332 mm	<b>13"</b>	332 mm	<b>13"</b>
Blade Types and Widths:				
VPAT, Straight	2782 mm	<b>109.5"</b>	3220 mm	<b>126.7"</b>
VPAT, Angled 25°	2636 mm	<b>103.8"</b>	2940 mm	<b>115.8"</b>
Fuel Tank Refill Capacity	195 L	<b>51.5 U.S. gal</b>	195 L	<b>51.5 U.S. gal</b>

\*Operating weight includes ROPS canopy, operator, lubricants, coolant, full fuel tank, hydraulic controls and fluids, back-up alarm, seat belts, lights, rigid drawbar, front pull device and standard service crankcase guard.



MODEL	D6K XL		D6K LGP		D6N XL		D6N LGP	
Flywheel Power:								
Hydrostatic	93.2 kW	<b>125 hp</b>	93.2 kW	<b>125 hp</b>	—	—	—	—
Power Shift	—	—	—	—	111.8 kW	<b>150 hp</b>	111.8 kW	<b>150 hp</b>
Operating Weight:								
Hydrostatic	12 886 kg	<b>28,409 lb</b>	13 467 kg	<b>29,690 lb</b>	—	—	—	—
Power Shift Differential Steer	—	—	—	—	16 668 kg	<b>36,747 lb</b>	17 997 kg	<b>39,712 lb</b>
Engine Model	<b>C6.6 ACERT</b>		<b>C6.6 ACERT</b>		<b>C6.6 ACERT</b>		<b>C6.6 ACERT</b>	
Rated Engine RPM	<b>2100</b>		<b>2100</b>		<b>2200</b>		<b>2200</b>	
No. of Cylinders	<b>6</b>		<b>6</b>		<b>6</b>		<b>6</b>	
Bore	105 mm	<b>4.13"</b>	105 mm	<b>4.13"</b>	105 mm	<b>4.13"</b>	105 mm	<b>4.13"</b>
Stroke	127 mm	<b>5.0"</b>	127 mm	<b>5.0"</b>	127 mm	<b>5.0"</b>	127 mm	<b>5.0"</b>
Displacement	6.6 L	<b>403 in<sup>3</sup></b>	6.6 L	<b>403 in<sup>3</sup></b>	6.6 L	<b>403 in<sup>3</sup></b>	6.6 L	<b>403 in<sup>3</sup></b>
Track Rollers (Each Side)	<b>7</b>		<b>7</b>		<b>7</b>		<b>8</b>	
Width of Standard Track Shoe	560 mm	<b>22"</b>	760 mm	<b>30"</b>	610 mm	<b>24"</b>	840 mm	<b>33"</b>
Length of Track on Ground	2645 mm	<b>104"</b>	2645 mm	<b>104"</b>	2611 mm	<b>103"</b>	3113 mm	<b>123"</b>
Ground Contact Area (w/Std. Shoe)	3.0 m <sup>2</sup>	<b>4650 in<sup>2</sup></b>	4.0 m <sup>2</sup>	<b>6200 in<sup>2</sup></b>	3.18 m <sup>2</sup>	<b>4929 in<sup>2</sup></b>	5.23 m <sup>2</sup>	<b>8107 in<sup>2</sup></b>
Track Gauge	1770 mm	<b>70"</b>	2000 mm	<b>79"</b>	1890 mm	<b>74.4"</b>	2160 mm	<b>85"</b>
GENERAL DIMENSIONS:								
Height (To Top of ROPS Canopy)	2958 mm	<b>116.5"</b>	2958 mm	<b>116.5"</b>	3040 mm	<b>119.7"</b>	3144 mm	<b>123.8"</b>
Height (To Top of ROPS Cab)	2958 mm	<b>116.5"</b>	2958 mm	<b>116.5"</b>	3095 mm	<b>121.9"</b>	3200 mm	<b>126"</b>
Overall Length (with VPAT Blade)	4688 mm	<b>185"</b>	4688 mm	<b>185"</b>	4903 mm	<b>193"</b>	5369 mm	<b>211.4"</b>
(without Blade)	4220 mm	<b>166"</b>	4220 mm	<b>166"</b>	3740 mm	<b>147.2"</b>	4165 mm	<b>164"</b>
(with SU Blade)	—	—	—	—	5157 mm	<b>203"</b>	—	—
Width (Over Trunnion)	—	—	—	—	2630 mm	<b>103.5"</b>	—	—
Width (w/o Trunnion — Std. Shoe)*	—	—	—	—	2500 mm	<b>98.4"</b>	3000 mm	<b>118"</b>
Width (w/o Trunnion and Blade — Std. Shoe)	2330 mm	<b>91.7"</b>	2760 mm	<b>108.7"</b>	—	—	—	—
Ground Clearance	360.4 mm	<b>14.2"</b>	360.4 mm	<b>14.2"</b>	394 mm	<b>15.5"</b>	507 mm	<b>20.0"</b>
Blade Types and Widths:								
Semi-U	—	—	—	—	3154 mm	<b>124"</b>	—	—
VPAT	3077 mm	<b>121.1"</b>	3360 mm	<b>132.3"</b>	3272 mm	<b>128.8"</b>	4080 mm	<b>160.6"</b>
Fuel Tank Refill Capacity	295 L	<b>77.9 U.S. gal</b>	295 L	<b>77.9 U.S. gal</b>	299 L	<b>79 U.S. gal</b>	299 L	<b>79 U.S. gal</b>

\*Width (w/o Trunnion — Std. Shoe) is also w/o VPAT Blade.



MODEL	D6G***		D6G Series 2 XL		D6G Series 2 LGP	
Flywheel Power	119 kW	160 hp	119 kW	160 hp	119 kW	160 hp
Operating Weight:* Power Shift	15 430 kg	34,017 lb	16 880 kg	37,219 lb	17 500 kg	38,588 lb
Engine Model	3306 T		3306 T		3306 T	
Rated Engine RPM: Power Shift	1900		1900		1900	
No. of Cylinders	6		6		6	
Bore	121 mm	4.75"	121 mm	4.75"	121 mm	4.75"
Stroke	152 mm	6"	152 mm	6"	152 mm	6"
Displacement	10.5 L	638 in <sup>3</sup>	10.5 L	638 in <sup>3</sup>	10.5 L	638 in <sup>3</sup>
Track Rollers (Each Side)	7		7		7	
Width of Standard Track Shoe	508 mm	20"	560 mm	22"	927 mm	36.5"
Length of Track on Ground	2.67 m	8'9"	2.67 m	8'9"	2.88 m	9'5"
Ground Contact Area (w/Std. Shoe)	2.72 m <sup>2</sup>	4216 in <sup>2</sup>	2.99 m <sup>2</sup>	4635 in <sup>2</sup>	5.34 m <sup>2</sup>	8276 in <sup>2</sup>
Track Gauge	1.88 m	6'2"	1.88 m	6'2"	2.11 m	6'11"
GENERAL DIMENSIONS:						
Height (Stripped Top)**	2.10 m	6'11"	2.16 m	7'1"	2.18 m	7'2"
Height (To Top of ROPS Canopy)	2.90 m	9'5"	3.14 m	10'4"	3.21 m	10'6"
Height (To Top of ROPS Cab)	3.10 m	10'3"	3.14 m	10'4"	3.21 m	10'6"
Overall Length (without Blade)	3.94 m	12'9"	3.94 m	12'11"	3.94 m	12'11"
with S Blade	5.00 m	16'4"	5.00 m	16'4"	5.20 m	17'1"
with SU Blade	—	—	5.30 m	17'4"	—	—
with Angle Blade	—	—	5.15 m	16'11"	—	—
Width (Over Trunnion)	—	—	2.65 m	8'8"	3.24 m	10'8"
Width (w/o Trunnion — Std. Shoe)	2.39 m	7'10"	2.44 m	8'0"	3.03 m	9'11"
Ground Clearance	310 mm	12.2"	310 mm	12.2"	310 mm	12.2"
Blade Types and Widths:						
Straight	3.20 m	10'6"	3.20 m	10'6"	3.70 m	12'2"
Angle Straight	3.90 m	12'9"	3.90 m	12'9"	—	—
Semi-U	3.20 m	10'6"	3.10 m	10'2"	—	—
Fuel Tank Refill Capacity	300 L	79 U.S. gal	320 L	84 U.S. gal	320 L	84 U.S. gal

\*Operating weight includes ROPS canopy, operator, lubricants, coolant, full fuel tank, hydraulic controls and fluids, straight dozer with tilt rigid drawbar, front towing device, engine enclosures and suspension seat.

\*\*Height (Stripped Top) — without ROPS canopy, exhaust, pre-cleaner, seat back or other easily removed encumbrances.

\*\*\*Not sold in U.S., Canada, Japan or Europe.



MODEL	D6R		D6R XL		D6R LGP	
Flywheel Power	130 kW	175 hp	145 kW	195 hp	145 kW	195 hp
Operating Weight:* Power Shift	18 325 kg	40,400 lb	20 080 kg	44,270 lb	21 716 kg	47,874 lb
Engine Model	C9		C9		C9	
Rated Engine RPM: Power Shift	2000		2000		2000	
No. of Cylinders	6		6		6	
Bore	112 mm	4.4"	112 mm	4.4"	112 mm	4.4"
Stroke	149 mm	5.9"	149 mm	5.9"	149 mm	5.9"
Displacement	8.8 L	537 in <sup>3</sup>	8.8 L	537 in <sup>3</sup>	8.8 L	537 in <sup>3</sup>
Track Rollers (Each Side)	6		7		8	
Width of Standard Track Shoe	560 mm	22"	560 mm	22"	915 mm	36"
Length of Track on Ground	2664 mm	105"	2871 mm	113"	3275 mm	129"
Ground Contact Area (w/Std.Shoe)	2.98 m <sup>2</sup>	4620 in <sup>2</sup>	3.22 m <sup>2</sup>	4972 in <sup>2</sup>	5.99 m <sup>2</sup>	9288 in <sup>2</sup>
Track Gauge	1880 mm	74"	1880 mm	74"	2286 mm	90"
GENERAL DIMENSIONS:						
Height (Stripped Top)**	3143 mm	10'4"	3143 mm	10'4"	3193 mm	10'6"
Height (To Top of ROPS Canopy)	3195 mm	10'6"	3195 mm	10'6"	3245 mm	10'8"
Height (To Top of ROPS Cab)	3195 mm	10'6"	3195 mm	10'6"	3245 mm	10'8"
Overall Length (without Blade)	3860 mm	12'8"	3860 mm	12'8"	4247 mm	13'11"
with S Blade	4903 mm	16'0"	—	—	5465 mm	17'9"
with SU Blade	5095 mm	16'7"	5332 mm	17'5"	—	—
with Angle Blade	5007 mm	16'4"	—	—	—	—
Width (over Trunnion)	2640 mm	8'8"	2640 mm	8'8"	3491 mm	11'5"
Width (w/o Trunnion — Std. track)	2440 mm	8'0"	2440 mm	8'0"	3201 mm	10'6"
Ground Clearance	383 mm	1'3"	383 mm	1'3"	433 mm	1'5"
Blade Types and Widths:						
Straight	3360 mm	11'0"	—	—	4063 mm	13'4"
Angle Straight	4166 mm	13'8"	4166 mm	13'8"	—	—
Semi-U	3260 mm	10'8"	3260 mm	10'8"	—	—
Fuel Tank Refill Capacity	424 L	112 U.S. gal	424 L	112 U.S. gal	424 L	112 U.S. gal

\*Operating weight includes ROPS canopy, operator, lubricants, coolant, full fuel tank, hydraulic controls and fluid, SU blade, horn, back-up alarm, retrieval hitch and front pull hook.

\*\*Height (Stripped Top) — without ROPS canopy, exhaust, seat back or other easily removed encumbrances.









MODEL	D6R Series 3		D6R Series 3 XL		D6R Series 3 XW		D6R Series 3 LGP	
Flywheel Power	138 kW	<b>185 hp</b>	149 kW	<b>200 hp</b>	149 kW	<b>200 hp</b>	149 kW	<b>200 hp</b>
Operating Weight:* Power Shift Differential Steer								
SU Blade	18 326 kg	<b>40,400 lb</b>	20 081 kg	<b>44,270 lb</b>	20 672 kg	<b>45,573 lb</b>	21 716 kg	<b>47,874 lb</b>
Engine Model	<b>C9 ACERT</b>		<b>C9 ACERT</b>		<b>C9 ACERT</b>		<b>C9 ACERT</b>	
Rated Engine RPM: Power Shift	<b>1850</b>		<b>1850</b>		<b>1850</b>		<b>1850</b>	
No. of Cylinders	<b>6</b>		<b>6</b>		<b>6</b>		<b>6</b>	
Bore	112 mm	<b>4.4"</b>	112 mm	<b>4.4"</b>	112 mm	<b>4.4"</b>	112 mm	<b>4.4"</b>
Stroke	149 mm	<b>5.9"</b>	149 mm	<b>5.9"</b>	149 mm	<b>5.9"</b>	149 mm	<b>5.9"</b>
Displacement	8.8 L	<b>537 in<sup>3</sup></b>	8.8 L	<b>537 in<sup>3</sup></b>	8.8 L	<b>537 in<sup>3</sup></b>	8.8 L	<b>537 in<sup>3</sup></b>
Track Rollers (Each Side)	<b>6</b>		<b>7</b>		<b>7</b>		<b>8</b>	
Width of Standard Track Shoe	560 mm	<b>22"</b>	560 mm	<b>22"</b>	760 mm	<b>30"</b>	915 mm	<b>36"</b>
VPAT	—		560 mm	<b>22"</b>	760 mm	<b>30"</b>	810 mm	<b>32"</b>
Length of Track on Ground	2.67 m	<b>8'9"</b>	2.87 m	<b>9'5"</b>	2.87 m	<b>9'5"</b>	3.28 m	<b>10'9"</b>
Ground Contact Area (w/Std. Shoe)	2.98 m <sup>2</sup>	<b>4620 in<sup>2</sup></b>	3.22 m <sup>2</sup>	<b>4972 in<sup>2</sup></b>	4.36 m <sup>2</sup>	<b>6780 in<sup>2</sup></b>	5.99 m <sup>2</sup>	<b>9288 in<sup>2</sup></b>
VPAT	—		3.22 m <sup>2</sup>	<b>4972 in<sup>2</sup></b>	4.36 m <sup>2</sup>	<b>6780 in<sup>2</sup></b>	5.31 m <sup>2</sup>	<b>8256 in<sup>2</sup></b>
Track Gauge	1.88 m	<b>74"</b>	1.88 m	<b>74"</b>	2.03 m	<b>80"</b>	2.29 m	<b>90"</b>
VPAT	—		2.13 m	<b>84"</b>	2.29 m	<b>90"</b>	2.29 m	<b>90"</b>
GENERAL DIMENSIONS:								
Height (Stripped Top)**	2.38 m	<b>7'10"</b>	2.38 m	<b>7'10"</b>	2.38 m	<b>7'10"</b>	2.43 m	<b>8'0"</b>
Height (To Top of ROPS Canopy)	3.20 m	<b>10'6"</b>	3.20 m	<b>10'6"</b>	3.20 m	<b>10'6"</b>	3.25 m	<b>10'8"</b>
Height (To Top of ROPS Cab)	3.19 m	<b>10'5"</b>	3.20 m	<b>10'6"</b>	3.20 m	<b>10'6"</b>	3.25 m	<b>10'8"</b>
Overall Length (without Blade)	3.86 m	<b>12'8"</b>	3.86 m	<b>12'8"</b>	3.86 m	<b>12'8"</b>	4.25 m	<b>13'11"</b>
with S Blade	4.90 m	<b>16'1"</b>	—		—		5.47 m	<b>17'11"</b>
with SU Blade	5.10 m	<b>16'9"</b>	5.33 m	<b>17'6"</b>	5.33 m	<b>17'6"</b>	—	
with VPAT Blade	—		5.27 m	<b>17'4"</b>	5.27 m	<b>17'4"</b>	5.97 m	<b>19'7"</b>
with Angle Blade	5.01 m	<b>16'5"</b>	5.21 m	<b>17'1"</b>	5.21 m	<b>17'1"</b>	—	
Overall Length (VPAT)	—		3.86 m	<b>12'8"</b>	3.86 m	<b>12'8"</b>	4.25 m	<b>13'11"</b>
with S Blade	—		—		—		5.47 m	<b>17'11"</b>
with SU Blade	—		5.33 m	<b>17'6"</b>	5.33 m	<b>17'6"</b>	—	
with VPAT Blade	—		5.27 m	<b>17'4"</b>	5.27 m	<b>17'4"</b>	5.97 m	<b>19'7"</b>
with Angle Blade	—		5.21 m	<b>17'1"</b>	5.21 m	<b>17'1"</b>	—	
Width (Over Trunnion)	2.64 m	<b>8'8"</b>	2.64 m	<b>8'8"</b>	2.95 m	<b>9'8"</b>	3.43 m	<b>8'8"</b>
Width (w/o Trunnion — Std. Track)	2.44 m	<b>8'0"</b>	2.44 m	<b>8'0"</b>	2.74 m	<b>9'0"</b>	3.15 m	<b>10'4"</b>
Ground Clearance	383 mm	<b>1'3"</b>	383 mm	<b>1'3"</b>	383 mm	<b>1'3"</b>	433 mm	<b>1'5"</b>
Blade Types and Widths:								
Straight	3.36 m	<b>11'0"</b>	—		—		4.06 m	<b>13'4"</b>
Angle Straight	4.17 m	<b>13'8"</b>	4.17 m	<b>13'8"</b>	4.20 m	<b>13'9"</b>	—	
Full 25° Angle	3.78 m	<b>12'5"</b>	3.78 m	<b>12'5"</b>	3.81 m	<b>12'6"</b>	—	
Semi-U	3.26 m	<b>10'8"</b>	3.26 m	<b>10'8"</b>	3.56 m	<b>11'8"</b>	—	
VPAT	—		—		—		—	
Straight	—		3.88 m	<b>12'9"</b>	4.16 m	<b>13'8"</b>	4.16 m	<b>13'8"</b>
Full 24° Angle	—		3.55 m	<b>11'8"</b>	3.81 m	<b>12'6"</b>	3.81 m	<b>12'6"</b>
Fuel Tank Refill Capacity	382 L	<b>101 U.S. gal</b>	382 L	<b>101 U.S. gal</b>	382 L	<b>101 U.S. gal</b>	382 L	<b>101 U.S. gal</b>

\*Operating weight includes ROPS canopy, operator, lubricants, coolant, full fuel tank, hydraulic controls and fluid, SU blade, horn, back-up alarm, retrieval hitch and front pull hook.

\*\*Height (Stripped Top) — without ROPS canopy, exhaust, seat back or other easily removed encumbrances.

MODEL								
	D6T		D6T XL		D6T XW		D6T LGP	
Flywheel Power	138 kW	<b>185 hp</b>	149 kW	<b>200 hp</b>	149 kW	<b>200 hp</b>	149 kW	<b>200 hp</b>
Operating Weight:**								
Power Shift Differential Steer								
SU Blade	19 429 kg	<b>42,841 lb</b>	20 449 kg	<b>45,090 lb</b>	21 301 kg	<b>46,968 lb</b>	22 039 kg	<b>48,588 lb</b>
Engine Model	<b>C9 ACERT</b>		<b>C9 ACERT</b>		<b>C9 ACERT</b>		<b>C9 ACERT</b>	
Rated Engine RPM: Power Shift	<b>1850</b>		<b>1850</b>		<b>1850</b>		<b>1850</b>	
No. of Cylinders	<b>6</b>		<b>6</b>		<b>6</b>		<b>6</b>	
Bore	112 mm	<b>4.4"</b>	112 mm	<b>4.4"</b>	112 mm	<b>4.4"</b>	112 mm	<b>4.4"</b>
Stroke	149 mm	<b>5.9"</b>	149 mm	<b>5.9"</b>	149 mm	<b>5.9"</b>	149 mm	<b>5.9"</b>
Displacement	8.8 L	<b>537 in<sup>3</sup></b>	8.8 L	<b>537 in<sup>3</sup></b>	8.8 L	<b>537 in<sup>3</sup></b>	8.8 L	<b>537 in<sup>3</sup></b>
Track Rollers (Each Side)	<b>6</b>		<b>7</b>		<b>7</b>		<b>8</b>	
Width of Standard Track Shoe	560 mm	<b>22"</b>	560 mm	<b>22"</b>	760 mm	<b>30"</b>	915 mm	<b>36"</b>
VPAT	—		560 mm	<b>22"</b>	710 mm	<b>28"</b>	785 mm	<b>31"</b>
Length of Track on Ground	2.63 m	<b>8'8"</b>	2.84 m	<b>9'4"</b>	2.84 m	<b>9'4"</b>	3.25 m	<b>10'8"</b>
Ground Contact Area (w/Std. Shoe)	2.94 m <sup>2</sup>	<b>4557 in<sup>2</sup></b>	3.18 m <sup>2</sup>	<b>4929 in<sup>2</sup></b>	4.31 m <sup>2</sup>	<b>6681 in<sup>2</sup></b>	5.95 m <sup>2</sup>	<b>9223 in<sup>2</sup></b>
VPAT	—		3.18 m <sup>2</sup>	<b>4929 in<sup>2</sup></b>	4.03 m <sup>2</sup>	<b>6247 in<sup>2</sup></b>	5.10 m <sup>2</sup>	<b>7905 in<sup>2</sup></b>
Track Gauge	1.88 m	<b>74"</b>	1.88 m	<b>74"</b>	2.03 m	<b>80"</b>	2.29 m	<b>90"</b>
VPAT	—		2.13 m	<b>84"</b>	2.29 m	<b>90"</b>	2.29 m	<b>90"</b>
GENERAL DIMENSIONS:								
Height** (Stripped Top)***	2.40 m	<b>7'10"</b>	2.44 m	<b>8'0"</b>	2.44 m	<b>8'0"</b>	2.45 m	<b>8'0"</b>
Height** (To Top of ROPS Canopy)	3.20 m	<b>10'6"</b>	3.20 m	<b>10'6"</b>	3.20 m	<b>10'6"</b>	3.25 m	<b>10'8"</b>
Height** (To Top of ROPS Cab)	3.11 m	<b>10'2"</b>	3.15 m	<b>10'4"</b>	3.15 m	<b>10'4"</b>	3.15 m	<b>10'4"</b>
Overall Length (without Blade)	3.86 m	<b>12'8"</b>	3.86 m	<b>12'8"</b>	3.86 m	<b>12'8"</b>	4.25 m	<b>13'11"</b>
with S Blade	4.90 m	<b>16'1"</b>	—		—		5.47 m	<b>17'11"</b>
with SU Blade	5.10 m	<b>16'9"</b>	5.33 m	<b>17'6"</b>	5.33 m	<b>17'6"</b>	—	
with VPAT Blade	—		5.27 m	<b>17'4"</b>	5.27 m	<b>17'4"</b>	5.97 m	<b>19'7"</b>
with Angle Blade	5.01 m	<b>16'5"</b>	5.21 m	<b>17'1"</b>	5.21 m	<b>17'1"</b>	5.82 m	<b>19'1"</b>
Width (Over Trunnion)	2.64 m	<b>8'8"</b>	2.64 m	<b>8'8"</b>	2.95 m	<b>9'8"</b>	3.43 m	<b>8'8"</b>
Width (w/o Trunnion — Std. Track)	2.44 m	<b>8'0"</b>	2.44 m	<b>8'0"</b>	2.79 m	<b>9'2"</b>	3.20 m	<b>10'6"</b>
Ground Clearance**	384 mm	<b>1'3"</b>	384 mm	<b>1'3"</b>	384 mm	<b>1'3"</b>	434 mm	<b>1'5"</b>
Blade Types and Widths:								
Straight	3.36 m	<b>11'0"</b>	—		—		4.06 m	<b>13'4"</b>
Angle Straight	4.17 m	<b>13'8"</b>	4.17 m	<b>13'8"</b>	4.50 m	<b>14'9"</b>	5.07 m	<b>16'8"</b>
Full 25° Angle	3.78 m	<b>12'5"</b>	3.78 m	<b>12'5"</b>	3.81 m	<b>12'6"</b>	4.63 m	<b>15'2"</b>
Semi-U	3.26 m	<b>10'8"</b>	3.26 m	<b>10'8"</b>	3.56 m	<b>11'8"</b>	—	
VPAT								
Straight	—		3.88 m	<b>12'9"</b>	4.16 m	<b>13'8"</b>	4.16 m	<b>13'8"</b>
Full 24° Angle	—		3.55 m	<b>11'8"</b>	3.81 m	<b>12'6"</b>	3.81 m	<b>12'6"</b>
Fuel Tank Refill Capacity	425 L	<b>112 U.S. gal</b>	425 L	<b>112 U.S. gal</b>	425 L	<b>112 U.S. gal</b>	425 L	<b>112 U.S. gal</b>

\*Operating weight includes cab, operator, lubricants, coolant, full fuel tank, standard track, hydraulic controls and fluid, SU blade, drawbar and counterweight.

\*\*Dimensions measured from ground line. Add grouser height for total dimension on hard surfaces.

\*\*\*Height (Stripped Top) — without ROPS canopy, exhaust, seat back or other easily removed encumbrances.

## Track-Type Tractor Sustainability

Well matched engine and power train systems enhance productivity and fuel efficiency.



MODEL	D6T XL		D6T XW		D6T LGP	
Engine Emissions Tier	Tier 4 Interim/Stage IIIB		Tier 4 Interim/Stage IIIB		Tier 4 Interim/Stage IIIB	
Flywheel Power	149 kW	200 hp	149 kW	200 hp	149 kW	200 hp
Operating Weight:* Power Shift Differential Steer	20 679 kg	45,590 lb	21,531 kg	47,468 lb	22,270 kg	49,096 lb
Engine Model	C9.3 ACERT		C9.3 ACERT		C9.3 ACERT	
Advertised Engine RPM	1850		1850		1850	
No. of Cylinders	6		6		6	
Bore	115 mm	4.5"	115 mm	4.5"	115 mm	4.5"
Stroke	149 mm	5.9"	149 mm	5.9"	149 mm	5.9"
Displacement	9.3 L	567 in <sup>3</sup>	9.3 L	567 in <sup>3</sup>	9.3 L	567 in <sup>3</sup>
Track Rollers (Each Side)	7		7		8	
Width of Standard Track Shoe	560 mm	22"	760 mm	30"	915 mm	36"
VPAT	560 mm	22"	710 mm	28"	785 mm	31"
Length of Track on Ground	2.84 m	9'4"	2.84 m	9'4"	3.25 m	10'8"
Ground Contact Area (w/Std.Shoe)	3.18 m <sup>2</sup>	4929 in <sup>2</sup>	4.31 m <sup>2</sup>	6681 in <sup>2</sup>	5.95 m <sup>2</sup>	9223 in <sup>2</sup>
VPAT	3.18 m <sup>2</sup>	4929 in <sup>2</sup>	4.03 m <sup>2</sup>	6247 in <sup>2</sup>	5.10 m <sup>2</sup>	7905 in <sup>2</sup>
Track Gauge	1.88 m	74"	2.03 m	80"	2.29 m	90"
VPAT	2.13 m	84"	2.29 m	90"	2.29 m	90"
GENERAL DIMENSIONS:						
Height** (Stripped Top***)	2.44 m	8'0"	2.44 m	8'0"	2.45 m	8'0"
Height** (To Top of ROPS Canopy)	3.11 m	10'2"	3.11 m	10'2"	3.16 m	10'5"
Height** (To Top of ROPS Cab)	3.15 m	10'4"	3.15 m	10'4"	3.15 m	10'4"
Overall Length (without Blade)	3.88 m	12'9"	3.88 m	12'9"	4.22 m	13'10"
with S Blade	—	—	—	—	5.43 m	17'10"
with SU Blade	5.34 m	17'6"	5.35 m	17'7"	—	—
with VPAT Blade	5.10 m	16'9"	5.37 m	17'7"	5.97 m	19'7"
with Angle Blade	5.22 m	17'2"	5.28 m	17'4"	5.80 m	19'0"
Width (Over Trunnion)	2.64 m	8'8"	2.95 m	9'8"	3.43 m	8'8"
Width (w/o Trunnion — Std. Track)	2.44 m	8'0"	2.79 m	9'2"	3.20 m	10'6"
Ground Clearance**	384 mm	1'3"	384 mm	1'3"	434 mm	1'5"
Blade Types and Widths:						
Straight	4.16 m	13'8"	4.52 m	14'10"	5.07 m	16'8"
Angle Straight	3.80 m	12'6"	4.13 m	13'7"	4.78 m	15'8"
Full 25° Angle	3.26 m	10'8"	3.57 m	11'9"	—	—
Semi-U	3.88 m	12'9"	4.16 m	13'8"	4.16 m	13'8"
VPAT Straight	3.54 m	11'7"	3.80 m	12'6"	3.80 m	12'6"
Fuel Tank Refill Capacity	425 L	112 U.S. gal	425 L	112 U.S. gal	425 L	112 U.S. gal

\*Operating weight includes cab, operator, lubricants, coolant, full fuel tank, standard track, hydraulic controls and fluid, SU blade and drawbar.

\*\*Dimensions measured from ground line. Add grouser height for total dimension on hard surfaces.

\*\*\*Height (Stripped Top) — without ROPS canopy, exhaust, seat back or other easily removed encumbrances.



MODEL	D7E		D7E LGP		D7E		D7E LGP	
Engine Emissions Tier	—		—		Tier 4 Interim/ Stage IIIB		Tier 4 Interim/ Stage IIIB	
Flywheel Power	175 kW	<b>235 hp</b>	175 kW	<b>235 hp</b>	—		—	
Advertised Flywheel Power	—		—		175 kW	<b>235 hp</b>	175 kW	<b>235 hp</b>
Operating Weight:* Electric Drive Differential Steer	25 700 kg	<b>56,669 lb</b>	28 170 kg	<b>62,115 lb</b>	25 996 kg	<b>57,310 lb</b>	28 465 kg	<b>62,755 lb</b>
Engine Model	<b>C9.3</b>		<b>C9.3</b>		<b>C9.3</b>		<b>C9.3</b>	
Rated Engine RPM	<b>1700</b>		<b>1700</b>		—		—	
Advertised Engine RPM	—		—		<b>1700</b>		<b>1700</b>	
No. of Cylinders	<b>6</b>		<b>6</b>		<b>6</b>		<b>6</b>	
Bore	115 mm	<b>4.5"</b>	115 mm	<b>4.5"</b>	115 mm	<b>4.5"</b>	115 mm	<b>4.5"</b>
Stroke	149 mm	<b>5.9"</b>	149 mm	<b>5.9"</b>	149 mm	<b>5.9"</b>	149 mm	<b>5.9"</b>
Displacement	9.3 L	<b>567 in<sup>3</sup></b>	9.3 L	<b>567 in<sup>3</sup></b>	9.3 L	<b>567 in<sup>3</sup></b>	9.3 L	<b>567 in<sup>3</sup></b>
Track Rollers (Each Side)	<b>7</b>		<b>8</b>		<b>7</b>		<b>8</b>	
Width of Standard Track Shoe	610 mm	<b>24"</b>	915 mm	<b>36"</b>	610 mm	<b>24"</b>	915 mm	<b>36"</b>
Length of Track on Ground	3.02 m	<b>9'11"</b>	3.45 m	<b>11'4"</b>	3.02 m	<b>9'11"</b>	3.45 m	<b>11'4"</b>
Ground Contact Area (w/Std. Shoe)	3.68 m <sup>2</sup>	<b>5698 in<sup>2</sup></b>	6.31 m <sup>2</sup>	<b>9792 in<sup>2</sup></b>	3.68 m <sup>2</sup>	<b>5698 in<sup>2</sup></b>	6.31 m <sup>2</sup>	<b>9792 in<sup>2</sup></b>
Track Gauge	1.98 m	<b>6'6"</b>	2.29 m	<b>7'6"</b>	1.98 m	<b>6'6"</b>	2.29 m	<b>7'6"</b>
GENERAL DIMENSIONS:								
Height** (To Top of ROPS Cab)	3.32 m	<b>10'11"</b>	3.32 m	<b>10'11"</b>	3.32 m	<b>10'11"</b>	3.32 m	<b>10'11"</b>
Overall Length (without Blade)	4.88 m	<b>16'0"</b>	4.88 m	<b>16'0"</b>	4.88 m	<b>16'0"</b>	4.88 m	<b>16'0"</b>
with S Blade	5.86 m	<b>19'3"</b>	5.56 m	<b>18'3"</b>	5.86 m	<b>19'3"</b>	5.56 m	<b>18'3"</b>
with SU Blade	6.07 m	<b>19'11"</b>	—	—	6.07 m	<b>19'11"</b>	—	—
Width (Over Trunnion)	2.88 m	<b>9'5"</b>	3.42 m	<b>11'3"</b>	2.88 m	<b>9'5"</b>	3.42 m	<b>11'3"</b>
Width (w/o Trunnion — Std. Shoe)	2.59 m	<b>8'6"</b>	3.2 m	<b>10'6"</b>	2.59 m	<b>8'6"</b>	3.2 m	<b>10'6"</b>
Ground Clearance	472 mm	<b>18.6"</b>	472 mm	<b>18.6"</b>	472 mm	<b>18.6"</b>	472 mm	<b>18.6"</b>
Blade Types and Widths:								
Straight	3.9 m	<b>12'10"</b>	4.54 m	<b>14'11"</b>	3.9 m	<b>12'10"</b>	4.54 m	<b>14'11"</b>
Angle Straight	4.5 m	<b>14'9"</b>	—	—	4.5 m	<b>14'9"</b>	—	—
Full 25° Angle	4.12 m	<b>13'6"</b>	—	—	4.12 m	<b>13'6"</b>	—	—
Universal	3.99 m	<b>13'1"</b>	—	—	3.99 m	<b>13'1"</b>	—	—
Semi-U	3.71 m	<b>12'2"</b>	—	—	3.71 m	<b>12'2"</b>	—	—
Fuel Tank Refill Capacity	409 L	<b>108 U.S.gal</b>	409 L	<b>108 U.S.gal</b>	409 L	<b>108 U.S.gal</b>	409 L	<b>108 U.S.gal</b>

\*Operating weight includes cab, operator, lubricants, coolant, full fuel tank, standard track, hydraulic controls and fluid, SU blade and drawbar.

\*\*Dimensions measured from ground line. Add grouser height for total dimension on hard surfaces.

### Cat D7E — Resourceful in every way

- The D7E is designed to maximize efficiency and productivity while conserving natural resources.
- Burns 10–30% less fuel per hour than previous models. Less fuel burned means reduced emissions.
- The D7E earned a 2009 Clean Air Excellence Award from the U.S. Environmental Protection Agency.
- More efficient – 25% more material moved per liter/gallon of fuel.
- Fewer parts and longer component life, less fuel and fluids, means less to replace and less to dispose.
- Major structures and components are built to be rebuilt, reducing waste and replacement costs.



MODEL	D7G†		D7G Series 2		D7R Series 2		D7R Series 2 XR	
Flywheel Power	150 kW	<b>202 hp</b>	149 kW	<b>200 hp</b>	179 kW	<b>240 hp</b>	179 kW	<b>240 hp</b>
Operating Weight:* Power Shift Clutch Brake (FTC) Power Shift Differential Steer	20 094 kg	<b>44,300 lb</b>	20 580 kg	<b>45,381 lb</b>	—	—	27 002 kg	<b>59,540 lb</b>
Engine Model	<b>3306 T</b>		<b>3306 DITA</b>		<b>3176C SCAC</b>		<b>3176C SCAC</b>	
Rated Engine RPM	<b>2000</b>		<b>2000</b>		<b>2100</b>		<b>2100</b>	
No. of Cylinders	<b>6</b>		<b>6</b>		<b>6</b>		<b>6</b>	
Bore	121 mm	<b>4.75"</b>	121 mm	<b>4.75"</b>	124 mm	<b>4.92"</b>	124 mm	<b>4.92"</b>
Stroke	152 mm	<b>6"</b>	152 mm	<b>6"</b>	140 mm	<b>5.5"</b>	140 mm	<b>5.5"</b>
Displacement	10.5 L	<b>638 in³</b>	10.5 L	<b>638 in³</b>	10.3 L	<b>629 in³</b>	10.3 L	<b>629 in³</b>
Track Rollers (Each Side)	<b>6</b>		<b>6</b>		<b>7</b>		<b>8</b>	
Width of Standard Track Shoe	508 mm	<b>20"</b>	560 mm	<b>22"</b>	560 mm	<b>22"</b>	610 mm	<b>24"</b>
Length of Track on Ground	2.72 m	<b>8'11"</b>	2.72 m	<b>8'11"</b>	2.87 m	<b>9'5"</b>	3.05 m	<b>10'0"</b>
Ground Contact Area (w/Std. Shoe)	2.76 m²	<b>4280 in²</b>	3.05 m²	<b>4738 in²</b>	3.21 m²	<b>4976 in²</b>	3.72 m²	<b>5766 in²</b>
Track Gauge	1.98 m	<b>6'6"</b>	1.98 m	<b>6'6"</b>	1.98 m	<b>6'6"</b>	1.98 m	<b>6'6"</b>
GENERAL DIMENSIONS:								
Height** (Stripped Top)***	2.27 m	<b>7'5"</b>	2.47 m	<b>8'1"</b>	2.58 m	<b>8'6"</b>	2.58 m	<b>8'6"</b>
Height** (To Top of ROPS Canopy)	3.25 m	<b>10'8"</b>	3.37 m	<b>11'1"</b>	3.29 m	<b>10'9"</b>	3.29 m	<b>10'9"</b>
Height** (To Top of ROPS Cab)	—	—	3.37 m	<b>11'1"</b>	3.28 m	<b>10'9"</b>	3.28 m	<b>10'9"</b>
Overall Length (without Blade)	4.19 m	<b>13'9"</b>	4.20 m	<b>13'9"</b>	4.73 m	<b>15'6"</b>	4.73 m	<b>15'6"</b>
with S Blade	5.28 m	<b>17'4"</b>	5.28 m	<b>17'4"</b>	5.81 m	<b>19'1"</b>	5.81 m	<b>19'1"</b>
Width (Over Trunnion)	—	—	—	—	2.88 m	<b>9'5"</b>	2.88 m	<b>9'5"</b>
Width (w/o Trunnion — Std. Shoe)	2.55 m	<b>8'5"</b>	2.55 m	<b>8'5"</b>	2.54 m	<b>8'4"</b>	2.59 m	<b>8'6"</b>
Ground Clearance	347 mm	<b>13.7"</b>	347 mm	<b>13.7"</b>	415 mm	<b>1'4"</b>	415 mm	<b>1'4"</b>
Blade Types and Widths:								
Straight	3.66 m	<b>12'0"</b>	3.66 m	<b>12'0"</b>	3.52 m	<b>11'7"</b>	3.32 m	<b>11'7"</b>
Angle Straight	4.27 m	<b>14'0"</b>	4.27 m	<b>14'0"</b>	4.50 m	<b>14'9"</b>	4.50 m	<b>14'9"</b>
Full 25° Angle	3.90 m	<b>12'10"</b>	3.90 m	<b>12'10"</b>	4.12 m	<b>13'6"</b>	4.12 m	<b>13'6"</b>
Universal	—	—	—	—	3.98 m	<b>13'1"</b>	3.98 m	<b>13'1"</b>
Semi-U	—	—	3.45 m	<b>11'4"</b>	3.69 m	<b>12'2"</b>	3.69 m	<b>12'2"</b>
Fuel Tank Refill Capacity	435 L	<b>115 U.S. gal</b>	415 L	<b>110 U.S. gal</b>	481 L	<b>127 U.S. gal</b>	481 L	<b>127 U.S. gal</b>

FTC — Fingertip clutch/brake control

\*Operating weight includes cab, operator, lubricants, coolant, full fuel tank, standard track, hydraulic controls and fluid, SU blade, drawbar and counterweight.  
— D7G includes ROPS canopy and end track guiding guards.

\*\*Dimensions measured from ground line. Add grouser height for total dimension on hard surfaces.

\*\*\*Height (Stripped Top) — without ROPS canopy, exhaust, seat back or other easily removed encumbrances.

†Not sold in U.S., Canada, Japan or Europe.

### Track-Type Tractor Sustainability

Major structures and components are built to be rebuilt, reducing waste and replacement costs.



MODEL	D7R Series 2 LGP		D8R		D8R LGP	
Flywheel Power	179 kW	240 hp	228 kW	305 hp	228 kW	305 hp
Operating Weight:*						
Power Shift Differential Steer	27 626 kg	60,916 lb	37 580 kg	82,850 lb	33 730 kg	74,360 lb
Engine Model	3176C SCAC		3406C TA		3406C TA	
Rated Engine RPM	2100		2100		2100	
No. of Cylinders	6		6		6	
Bore	124 mm	4.92"	137 mm	5.4"	137 mm	5.4"
Stroke	140 mm	5.5"	165 mm	6.5"	165 mm	6.5"
Displacement	10.3 L	629 in <sup>3</sup>	14.6 L	893 in <sup>3</sup>	14.6 L	893 in <sup>3</sup>
Track Rollers (Each Side)	7		8		8	
ERF††	9		—		—	
Width of Standard Track Shoe	914 mm	36"	610 mm	24"	965 mm	38"
Length of Track on Ground	3.16 m	10'5"	3.21 m	10'6"	3.20 m	10'6"
Ground Contact Area (w/Std. Shoe)	5.78 m <sup>2</sup>	8960 in <sup>2</sup>	3.91 m <sup>2</sup>	6062 in <sup>2</sup>	6.2 m <sup>2</sup>	9576 in <sup>2</sup>
Track Gauge	2.24 m	7'4"	2.08 m	6'10"	2.34 m	7'8"
GENERAL DIMENSIONS:						
Height** (Stripped Top)***	2.70 m	8'10"	2.67 m	8'9"	2.67 m	8'9"
Height** (To Top of ROPS Canopy)	3.40 m	11'2"	3.51 m	11'6"	3.51 m	11'6"
Height** (To Top of ROPS Cab)	3.39 m	11'1"	3.45 m	11'3"	3.45 m	11'3"
Overall Length (with SU Blade)†	—	—	6.91 m	22'8"	6.91 m	22'8"
(without Blade)	—	—	4.93 m	16'2"	4.93 m	16'2"
Overall Length (without Blade)	4.73 m	15'6"	—	—	—	—
(with S Blade)	5.81 m	19'1"	—	—	—	—
Width (Over Trunnion)	3.37 m	11'1"	3.05 m	10'0"	3.55 m	11'7"
Width (w/o Trunnion — Std. Shoe)	3.15 m	10'4"	2.70 m	8'8"	3.30 m	10'10"
Ground Clearance	495 mm	1'7"	606 mm	1'11"	574 mm	1'11"
Blade Types and Widths:						
Straight	4.55 m	14'11"	—	—	—	—
Angle Straight	—	—	4.99 m	16'4"	—	—
Full 25° Angle	—	—	4.52 m	14'10"	—	—
Universal	—	—	4.26 m	14'0"	—	—
Semi-U	—	—	3.94 m	12'11"	4.40 m	14'5"
Fuel Tank Refill Capacity	481 L	127 U.S. gal	625 L	165 U.S. gal	625 L	165 U.S. gal

\*Operating weight includes cab, operator, lubricants, coolant, full fuel tank, standard track, hydraulic controls and fluid, SU blade, drawbar and counterweight.

— D8R equipped with track guides, ROPS/FOPS cab, single shank ripper and SU blade.

\*\*Dimensions measured from ground line. Add grouser height for total dimension on hard surfaces.

\*\*\*Height (Stripped Top) — without ROPS canopy, exhaust, seat back or other easily removed encumbrances.

†Includes drawbar.

††ERF — Extended Track Roller Frame. Extends frame 302 mm (11.9"), adds 3 track sections and 2 rollers/side.

## Track-Type Tractor Sustainability

Cat tractors are designed for ease of serviceability, with features like ground-level service points and wide engine enclosure doors.



MODEL	D8T		D8T LGP		D8T		D8T LGP	
Engine Emissions Tier	—		—		Tier 4 Interim/ Stage IIIB		Tier 4 Interim/ Stage IIIB	
Flywheel Power	231 kW	<b>310 hp</b>	231 kW	<b>310 hp</b>	231 kW	<b>310 hp</b>	231 kW	<b>310 hp</b>
Operating Weight:* Power Shift Differential Steer	38 488 kg	<b>84,850 lb</b>	38 488 kg	<b>84,850 lb</b>	38 941 kg	<b>85,850 lb</b>	38 941 kg	<b>85,850 lb</b>
Engine Model	<b>C15 ACERT</b>		<b>C15 ACERT</b>		<b>C15 ACERT</b>		<b>C15 ACERT</b>	
Rated Engine RPM	<b>1850</b>		<b>1850</b>		<b>1850</b>		<b>1850</b>	
No. of Cylinders	<b>6</b>		<b>6</b>		<b>6</b>		<b>6</b>	
Bore	137 mm	<b>5.4"</b>	137 mm	<b>5.4"</b>	137 mm	<b>5.4"</b>	137 mm	<b>5.4"</b>
Stroke	172 mm	<b>6.75"</b>	172 mm	<b>6.75"</b>	172 mm	<b>6.75"</b>	172 mm	<b>6.75"</b>
Displacement	15.2 L	<b>928 in<sup>3</sup></b>	15.2 L	<b>928 in<sup>3</sup></b>	15.2 L	<b>928 in<sup>3</sup></b>	15.2 L	<b>928 in<sup>3</sup></b>
Track Rollers (Each Side)	<b>8</b>		<b>8</b>		<b>8</b>		<b>8</b>	
Width of Standard Track Shoe	610 mm	<b>24"</b>	965 mm	<b>38"</b>	610 mm	<b>24"</b>	965 mm	<b>38"</b>
Length of Track on Ground	3.21 m	<b>10'6"</b>	3.20 m	<b>10'6"</b>	3.21 m	<b>10'6"</b>	3.20 m	<b>10'6"</b>
Ground Contact Area (w/Std. Shoe)	3.91 m <sup>2</sup>	<b>6062 in<sup>2</sup></b>	6.2 m <sup>2</sup>	<b>9576 in<sup>2</sup></b>	3.91 m <sup>2</sup>	<b>6062 in<sup>2</sup></b>	6.2 m <sup>2</sup>	<b>9576 in<sup>2</sup></b>
Track Gauge	2.08 m	<b>6'10"</b>	2.34 m	<b>7'8"</b>	2.08 m	<b>6'10"</b>	2.34 m	<b>7'8"</b>
GENERAL DIMENSIONS:								
Height** (Stripped Top)***	2.67 m	<b>8'9"</b>	2.67 m	<b>8'9"</b>	2.67 m	<b>8'9"</b>	2.67 m	<b>8'9"</b>
Height** (To Top of ROPS Canopy)	3.46 m	<b>11'4"</b>	3.45 m	<b>11'4"</b>	3.46 m	<b>11'4"</b>	3.45 m	<b>11'4"</b>
Height** (To Top of ROPS Cab)	3.46 m	<b>11'4"</b>	3.45 m	<b>11'4"</b>	3.46 m	<b>11'4"</b>	3.45 m	<b>11'4"</b>
Overall Length (with SU Blade)†	6.09 m	<b>20'0"</b>	6.09 m	<b>20'0"</b>	6.09 m	<b>20'0"</b>	6.09 m	<b>20'0"</b>
(without Blade)	4.64 m	<b>15'3"</b>	4.98 m	<b>16'4"</b>	4.64 m	<b>15'3"</b>	4.98 m	<b>16'4"</b>
Width (Over Trunnion)	3.06 m	<b>10'0"</b>	3.06 m	<b>10'0"</b>	3.06 m	<b>10'0"</b>	3.06 m	<b>10'0"</b>
Width (w/o Trunnion — Std. Shoe)	2.64 m	<b>8'8"</b>	2.64 m	<b>8'8"</b>	2.64 m	<b>8'8"</b>	2.64 m	<b>8'8"</b>
Ground Clearance	618 mm	<b>2'4"</b>	609 mm	<b>2'0"</b>	618 mm	<b>2'4"</b>	609 mm	<b>2'0"</b>
Blade Types and Widths:								
Angle Straight	4.99 m	<b>16'4"</b>	—	—	4.99 m	<b>16'4"</b>	—	—
Full 25° Angle	4.52 m	<b>14'10"</b>	—	—	4.52 m	<b>14'10"</b>	—	—
Universal	4.26 m	<b>14'0"</b>	—	—	4.26 m	<b>14'0"</b>	—	—
Semi-U	3.94 m	<b>12'11"</b>	4.40 m	<b>14'5"</b>	3.94 m	<b>12'11"</b>	4.40 m	<b>14'5"</b>
Fuel Tank Refill Capacity	643 L	<b>170 U.S. gal</b>	643 L	<b>170 U.S. gal</b>	643 L	<b>170 U.S. gal</b>	643 L	<b>170 U.S. gal</b>

\*Operating weight includes ROPS canopy, operator, lubricants, coolant, full fuel tank, hydraulic controls and fluids, semi universal blade with tilt, back-up alarm, seat belts, lights, rigid drawbar and front towing device.

\*\*Dimensions measured from ground line. Add grouser height for total dimension on hard surfaces.

\*\*\*Height (Stripped Top) — without ROPS canopy, exhaust, seat back or other easily removed encumbrances.

†Includes drawbar.

### Track-Type Tractor Sustainability

Cat engines with ACERT™ Technology provide powerful reliability, while meeting the toughest emissions standards.



MODEL	D9R		D9T	
Flywheel Power	302 kW	405 hp	306 kW	410 hp
Operating Weight:* Power Shift Clutch Brake	48 784 kg	107,548 lb	—	—
Power Shift Differential Steer	—	—	47 900 kg	105,600 lb
Engine Model	3408C SCAC		C18 ACERT	
Rated Engine RPM	1900		1800	
No. of Cylinders	8		6	
Bore	137 mm	5.4"	145 mm	5.7"
Stroke	152 mm	6"	183 mm	7.2"
Displacement	18 L	1099 in <sup>3</sup>	18.1 L	1104 in <sup>3</sup>
Track Rollers (Each Side)	8		8	
Width of Standard Track Shoe	610 mm	24"	610 mm	24"
Length of Track on Ground	3.47 m	11'5"	3.47 m	11'5"
Ground Contact Area (w/Std. Shoe)	4.24 m <sup>2</sup>	6569 in <sup>2</sup>	4.24 m <sup>2</sup>	6569 in <sup>2</sup>
Track Gauge	2.25 m	7'5"	2.25 m	7'5"
GENERAL DIMENSIONS:				
Height** (Stripped Top)***	3.00 m	9'10"	—	—
Height** (To Top of ROPS Canopy)	3.99 m	13'1"	4.00 m	13'1"
Height** (To Top of ROPS Cab)	3.82 m	12'6"	3.82 m	12'6"
Overall Length (with SU Blade)†	6.84 m	22'5"	—	—
(without Blade)	5.18 m	17'0"	—	—
(with SU Blade and Ripper)	—	—	6.63 m	21'10"
(without Blade and Ripper)	—	—	4.91 m	16'1"
Width (Over Trunnion)	3.30 m	10'10"	3.31 m	10'11"
Width (w/o Trunnion — Std. Shoe)	2.93 m	9'8"	2.87 m	9'5"
Ground Clearance	591 mm	1'11"■	596 mm	1'11"
Blade Types and Widths:				
Universal	4.65 m	15'3"	4.65 m	15'3"
Semi-U	4.31 m	14'2"	4.31 m	14'2"
Fuel Tank Refill Capacity	818 L	216 U.S. gal	889 L	235 U.S. gal

\*Operating weight includes ROPS canopy, operator, lubricants, coolant, full fuel tank, hydraulic controls and fluids, semi universal blade with tilt, back-up alarm, seat belts, lights, rigid drawbar and front towing device.

— D9R equipped with track guides, ROPS/FOPS cab, single shank ripper and SU blade.

\*\*Dimensions measured from ground line. Add grouser height for total dimension on hard surfaces.

\*\*\*Height (Stripped Top) — without ROPS canopy, exhaust, seat back or other easily removed encumbrances.

†Includes drawbar.

■SAE J1234.





MODEL	D10T		D11T		D11T CD	
Flywheel Power	433 kW	580 hp	634 kW	850 hp	634 kW	850 hp
Operating Weight:*						
Power Shift Clutch Brake	66 451 kg	146,500 lb	104 600 kg	230,100 lb	113 000 kg	248,600 lb
Engine Model	C27 ACERT		C32 ACERT		C32 ACERT	
Rated Engine RPM	1800		1800		1800	
No. of Cylinders	12		12		12	
Bore	137 mm	5.4"	145 mm	5.71"	145 mm	5.71"
Stroke	152 mm	6"	162 mm	6.38"	162 mm	6.38"
Displacement	27 L	1647.5 in <sup>3</sup>	32.1 L	1959 in <sup>3</sup>	32.1 L	1959 in <sup>3</sup>
Track Rollers (Each Side)	8		8		8	
Width of Standard Track Shoe	610 mm	24"	710 mm	28"	915 mm	36"
Length of Track on Ground (Idler to Idler)	3.88 m	12'9"	4.44 m	14'7"	4.44 m	14'7"
Ground Contact Area (w/Std. Shoe)	4.74 m <sup>2</sup>	7347 in <sup>2</sup>	6.31 m <sup>2</sup>	9781 in <sup>2</sup>	8.1 m <sup>2</sup>	12,581 in <sup>2</sup>
Track Gauge	2.55 m	8'4"	2.89 m	9'6"	2.89 m	9'6"
GENERAL DIMENSIONS:						
Height (Stripped Top)**	3.222 m	10'7"	3.64 m	11'11"	3.64 m	11'11"
Height (To Top of ROPS Canopy)	4.26 m	14'0"	4.60 m	15'1"	4.60 m	15'1"
Height (To Top of ROPS Cab)	4.01 m	13'2"	4.29 m	14'1"	4.29 m	14'1"
Overall Length:						
(with SU Blade and SS Ripper)***	9.16 m	30'1"	10.59 m	34'9"	10.70 m	35'1"
(without Blade and Ripper)†	5.331 m	17'6"	6.03 m	19'9"	6.03 m	19'9"
Width (Over Trunnion)	3.74 m	12'3"	4.38 m	14'4"	4.38 m	14'4"
Width (w/o Trunnion — Std. Shoe)	3.30 m	10'10"	3.78 m	12'5"	3.81 m	12'6"
Ground Clearance††	571 mm	1'10"	574 mm	1'11"	574 mm	1'11"
Blade Types and Widths:						
CarryDozer		—		—	6.71 m	22'0"
Universal	5.26 m	17'3"	6.36 m	20'10"		—
Semi-U	4.86 m	15'11"	5.60 m	18'4"		—
Fuel Tank Refill Capacity	1204 L	318 U.S. gal	1609 L	425 U.S. gal	1609 L	425 U.S. gal
Fuel Tank Refill Capacity (Extra Capacity)		—	1987 L	505 U.S. gal	1987 L	505 U.S. gal

\*Operating weight includes operator, lubricants, coolant, full fuel tank, hydraulic controls and fluids, SU blade with tilt, back-up alarm, seat belts, lights, rigid drawbar and front towing device.

\*\*Height (Stripped Top) — without ROPS canopy, cab, exhaust, lift cylinders, seat back or other easily removed encumbrances.

\*\*\*Overall length of D11T CD includes Straight (CarryDozer) Blade and SS Ripper.

†Overall length of machine from front tag link trunion to rigid drawbar and excludes track grouser height.

††SAE J1234.

All dimensions are approximate.

D3K XL  
D3K LGP

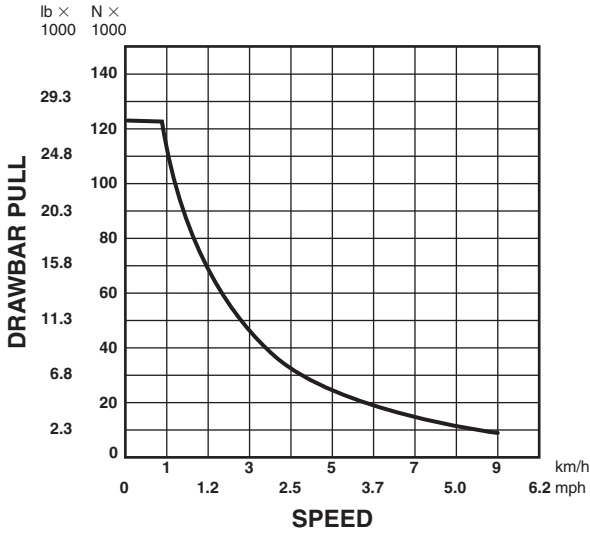

D4K XL  
D4K LGP

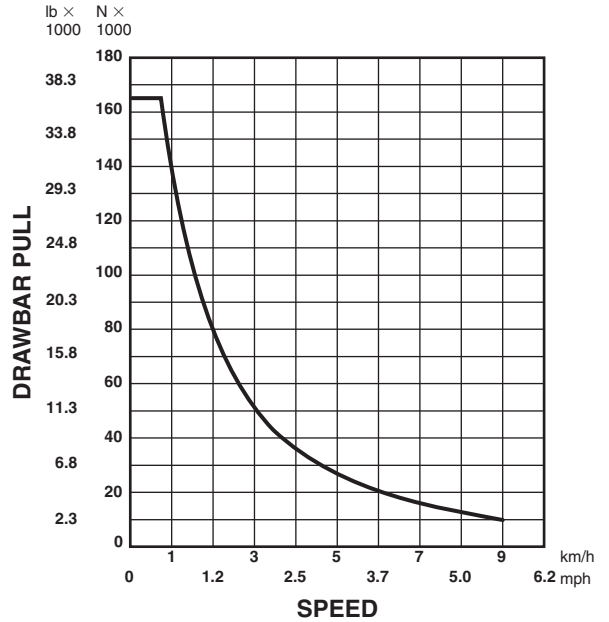

D5K XL  
D5K LGP

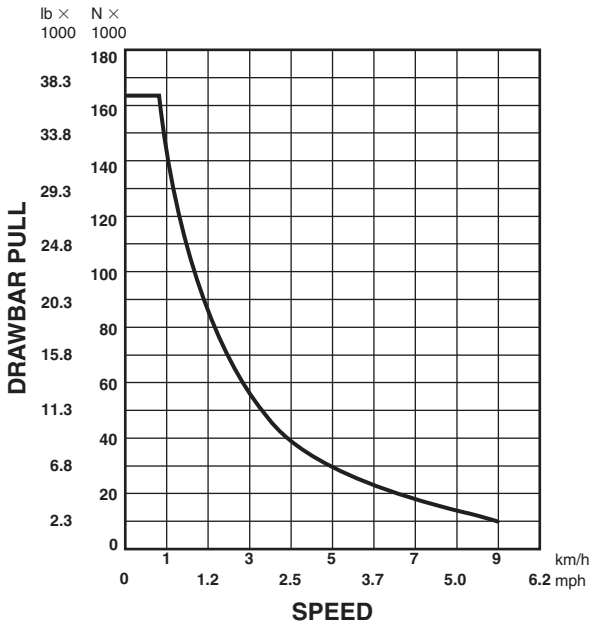

**NOTES:** Usable pull will depend upon weight and traction of equipped tractor.

Assumes sufficient machine weight for <5% track slip at POR pressure.

Assumes pumps and motors are broken in.

Assumes nominal engine power and valve settings.

Drawbar pull at track stall will be lower.

**D6G/D6G Series 2 XL/  
 D6G Series 2 LGP**

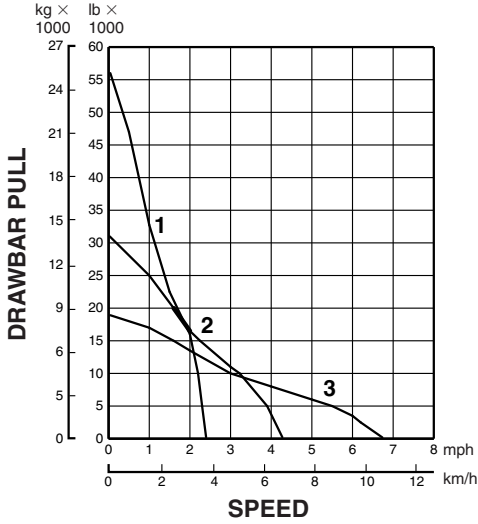

**D6N  
 Differential Steering (D/S)**

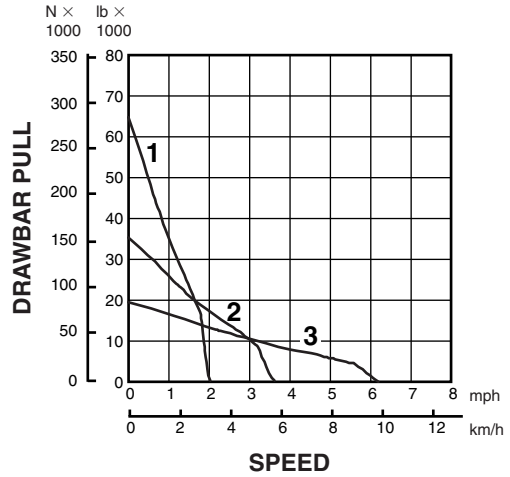

**D6R**

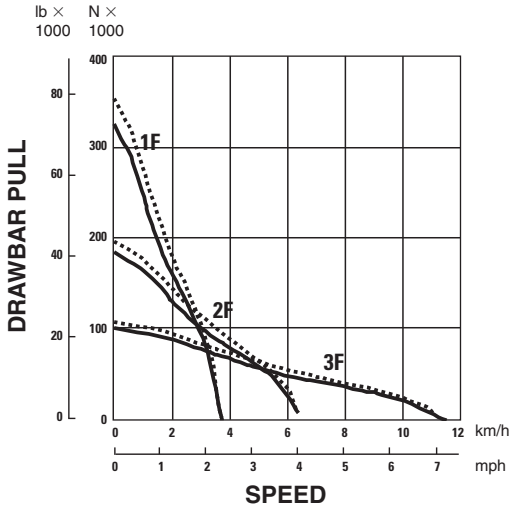

**D6R Series 3**

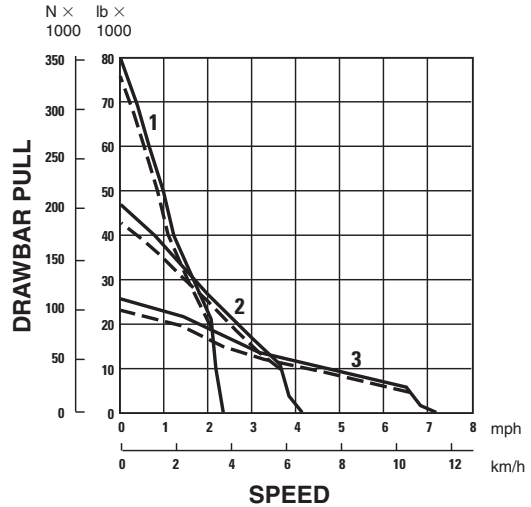

**KEY**

- STD
- - - XL/LGP

**KEY**

- 1 — 1st Gear
- 2 — 2nd Gear
- 3 — 3rd Gear

**KEY**

- - - STD
- XL/XW/LGP

**NOTE:** Usable pull will depend upon weight and traction of equipped tractor.

D6T Standard

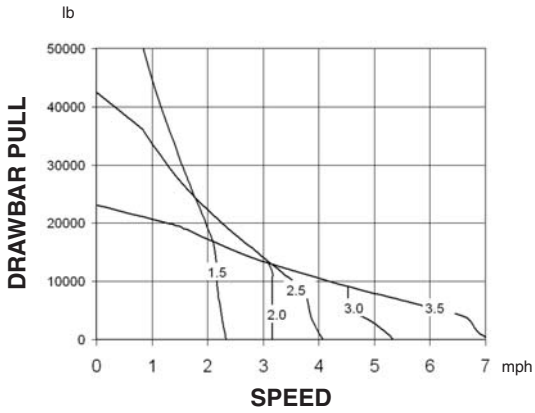

D6T XL/XW/LGP

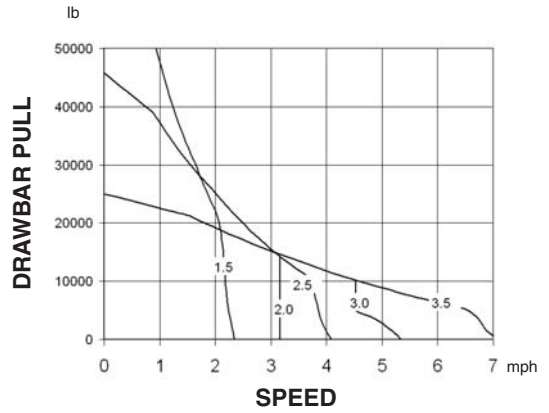

D7E

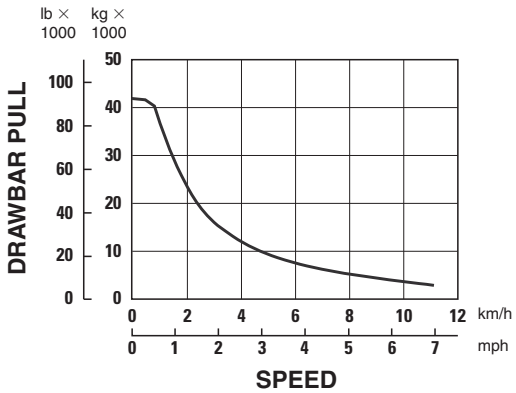

**D7G/D7G Series 2**

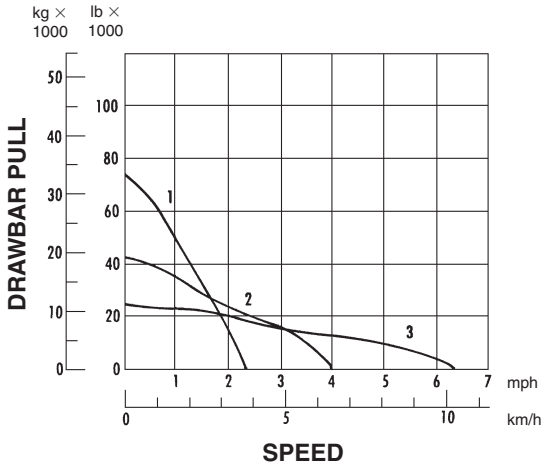

**D7R Series 2 Standard/XR/LGP  
 Differential Steer**

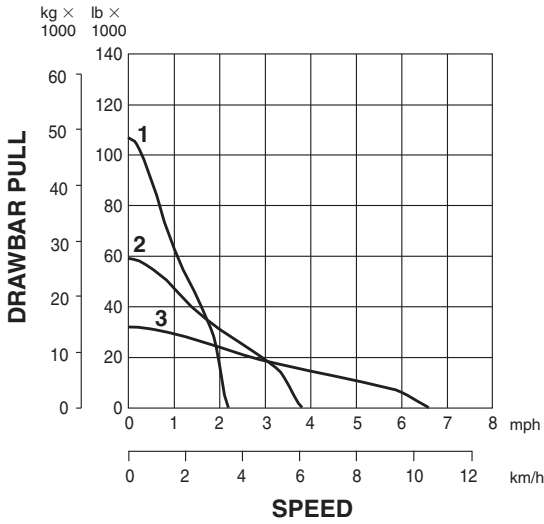

**KEY**

- 1 — 1st Gear
- 2 — 2nd Gear
- 3 — 3rd Gear

**NOTE:** Usable pull will depend upon weight and traction of equipped tractor.

**D8R  
D8R LGP**

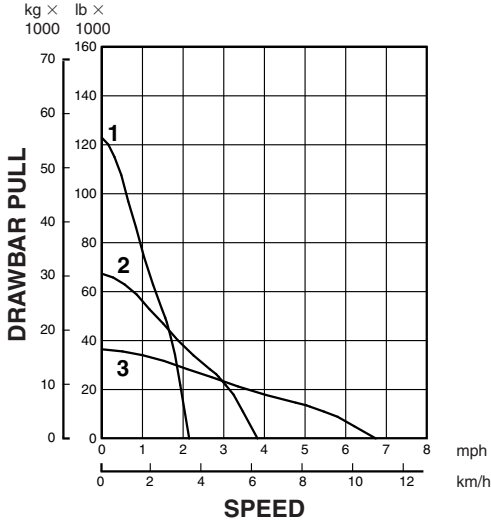

**D8T  
D8T LGP**

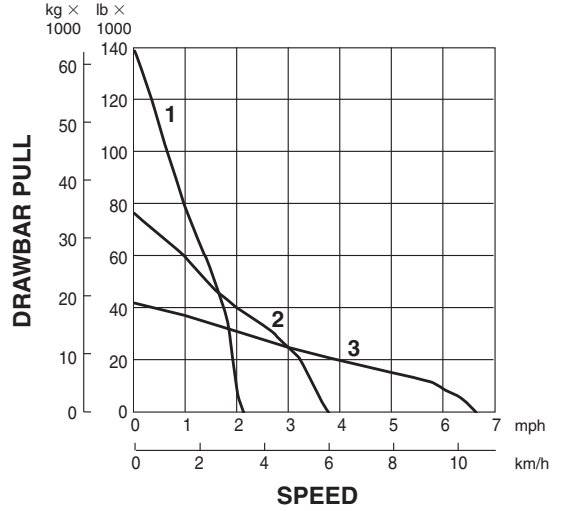

**D9R Power Shift with  
Steering Clutches and Brakes**

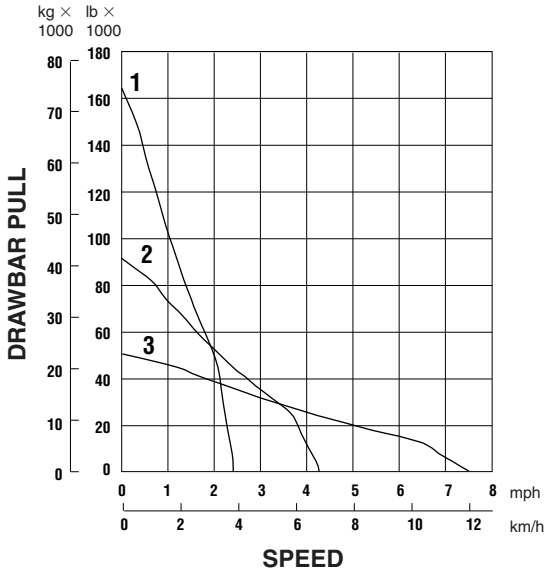

**KEY**

- 1 — 1st Gear
- 2 — 2nd Gear
- 3 — 3rd Gear

**NOTE:** Usable pull will depend upon weight and traction of equipped tractor.

D9T Differential Steering

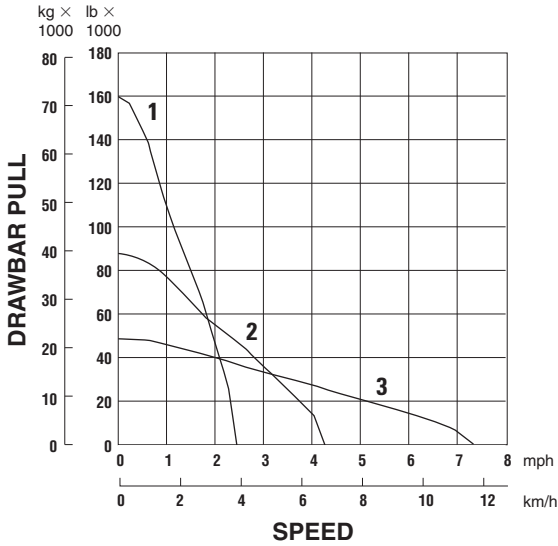

D10T

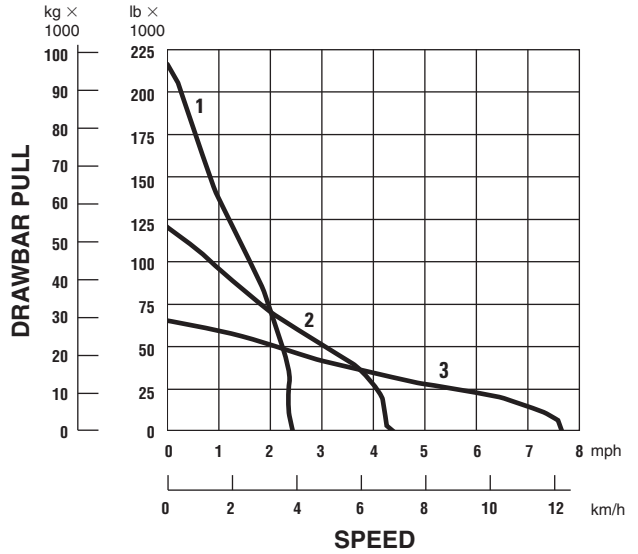

D11T/D11T CD

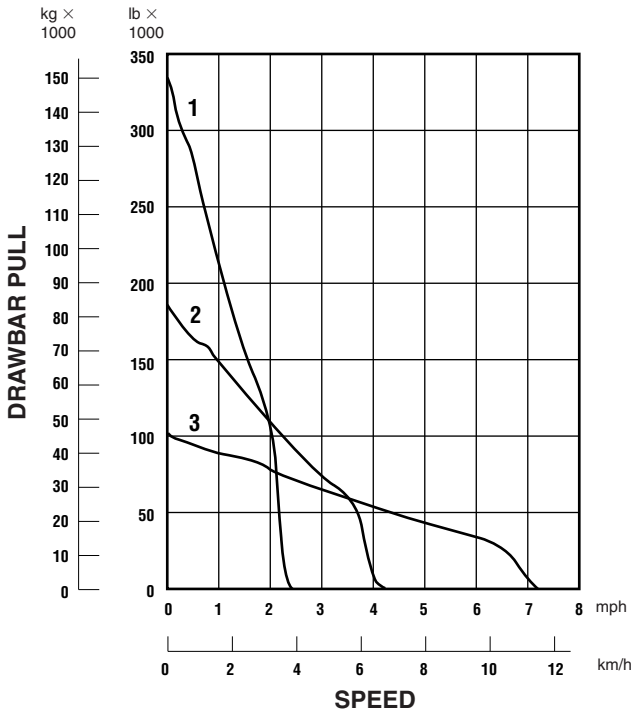

KEY

- 1 — 1st Gear
- 2 — 2nd Gear
- 3 — 3rd Gear

**NOTE:** Usable pull will depend upon weight and traction of equipped tractor. Tractors with suspended undercarriage can provide up to 15% more tractive effort than tractors with non-suspended undercarriage.

## TRAVEL SPEED

POWER SHIFT MODEL	D3K All Models		D4K All Models		D5K All Models		D6K All Models		D6N FTC	
	km/h	mph	km/h	mph	km/h	mph	km/h	mph	km/h	mph
FORWARD	—	—	—	—	—	—	—	—	3.1	1.9
1	—	—	—	—	—	—	—	—	5.7	3.5
2	—	—	—	—	—	—	—	—	10.0	6.2
3	—	—	—	—	—	—	—	—	—	—
REVERSE	—	—	—	—	—	—	—	—	3.1	1.9
1	—	—	—	—	—	—	—	—	6.4	4.0
2	—	—	—	—	—	—	—	—	11.6	7.2
3	—	—	—	—	—	—	—	—	—	—
HYDROSTATIC	—	—	—	—	—	—	—	—	—	—
FORWARD	9.0	5.6	9.0	5.6	9.0	5.6	0-10.0	0-6.2	—	—
REVERSE	10.0	6.2	10.0	6.2	10.0	6.2	0-10.0	0-6.2	—	—

POWER SHIFT MODEL	D6N D/S		D6G/ D6G Series 2 XL/ D6G Series 2 LGP		Differential Steer D6R		Differential Steer D6R Series 3		D6T		D7E		D7E LGP	
	km/h	mph	km/h	mph	km/h	mph	km/h	mph	km/h	mph	km/h	mph	km/h	mph
FORWARD	3.4	2.1	4.0	2.5	3.8	2.3	3.8	2.3	3.8	2.3	—	—	—	—
1	5.9	3.7	6.9	4.3	6.6	4.1	3.8	2.3	6.6	4.1	—	—	—	—
2	9.9	6.2	10.8	6.7	11.5	7.1	11.4	7.1	11.4	7.1	—	—	—	—
3	—	—	—	—	—	—	—	—	—	—	—	—	—	—
REVERSE	3.8	2.4	4.8	3.0	4.8	3.0	4.8	3.0	4.8	3.0	—	—	—	—
1	7.2	4.5	8.4	5.2	8.4	5.2	8.4	5.2	8.4	5.2	—	—	—	—
2	11.7	7.3	12.9	8.0	14.6	9.1	14.5	9.0	14.6	9.0	—	—	—	—
3	—	—	—	—	—	—	—	—	—	—	11.3	7.0	11.3	7.0
ELECTRIC	—	—	—	—	—	—	—	—	—	—	11.3	7.0	11.3	7.0
FORWARD	—	—	—	—	—	—	—	—	—	—	—	—	—	—
REVERSE	—	—	—	—	—	—	—	—	—	—	—	—	—	—

POWER SHIFT MODEL	D7G		D7G Series 2		D7R Series 2	
	km/h	mph	km/h	mph	km/h	mph
FORWARD	3.7	2.3	3.9	2.4	3.5	2.2
1	6.4	4.0	6.9	4.3	6.2	3.8
2	10.0	6.2	9.9	6.1	10.7	6.7
3	—	—	—	—	—	—
REVERSE	4.5	2.8	4.5	2.8	4.6	2.9
1	7.9	4.9	8.4	5.2	8.0	5.0
2	11.9	7.4	12.7	7.9	13.8	8.6
3	—	—	—	—	—	—

\*Power Shift direct drive transmission available for Japan domestic market only.

\*\*Not available at time of printing.



**TRAVEL SPEED**

POWER SHIFT MODEL	Differential Steer		D8T		D9R		D9T		D10T		D11T/CD		D11T/CD High Altitude	
	km/h	mph	km/h	mph	km/h	mph	km/h	mph	km/h	mph	km/h	mph	km/h	mph
FORWARD														
1	3.5	2.2	3.4	2.1	3.8	2.4	3.9	2.4	4.0	2.5	3.9	2.4	4.0	2.5
2	6.2	3.9	6.1	3.8	6.8	4.2	6.8	4.2	7.2	4.5	6.8	4.2	7.0	4.4
3	10.8	6.7	10.6	6.6	11.9	7.4	11.7	7.3	12.7	7.9	11.8	7.3	12.0	7.5
REVERSE														
1	4.7	2.9	4.5	2.8	4.7	2.9	4.7	2.9	5.2	3.2	4.7	2.9	4.8	3.0
2	8.1	5.0	8.0	5.0	8.4	5.2	8.4	5.2	9.0	5.6	8.2	5.1	8.3	5.2
3	13.9	8.6	14.2	8.8	14.7	9.1	14.3	8.9	15.8	9.8	14.0	8.7	14.9	9.0

DIRECT DRIVE MODEL	D6R Series 3* P.S./D.D.	
FORWARD	km/h	mph
1	3.4	2.1
2	5.9	3.7
3	10.4	6.5
4		—
5		—
6		—
REVERSE		
1	4.3	2.7
2	7.5	4.7
3	13.3	8.3
4		—
5		—
6		—

\*Japan only.

GEAR	D6T Powershift with Multi Velocity Program		D6T Powershift with Multi Velocity Program — Sound Suppressed		D6T Tier 4 Interim/Stage IIIB Powershift with Multi Velocity Program		D6T Tier 4 Interim/Stage IIIB Powershift with Multi Velocity Program — Sound Suppressed	
	km/h	mph	km/h	mph	km/h	mph	km/h	mph
FORWARD								
1.5	3.8	2.3	3.2	2.0	3.8	2.3	3.2	2.0
2	5.1	3.2	5.1	3.2	5.1	3.2	5.1	3.2
2.5	6.6	4.1	6.3	3.9	6.6	4.1	6.3	3.9
3	8.5	5.3	8.5	5.3	8.5	5.3	8.5	5.3
3.5	11.4	7.1	10.9	6.8	11.4	7.1	10.9	6.8
REVERSE								
1.5	4.8	3.0	3.9	2.4	4.8	3.0	3.9	2.4
2	6.6	4.1	6.6	4.1	6.6	4.1	6.6	4.1
2.5	8.4	5.2	8.0	5.0	8.4	5.2	8.0	5.0
3	11.0	6.8	11.0	6.8	8.7	5.4	8.7	5.4
3.5	14.6	9.0	13.8	8.6	14.6	9.0	13.8	8.6

## GROUND PRESSURES

Pressures computed from operating weights given earlier in this section in the specifications tables.

MODEL	SHOE WIDTH		CONTACT AREA		GROUND PRESSURE	
	mm	in	m <sup>2</sup>	in <sup>2</sup>	kPa	psi
D3K XL	406	16	1.7	2637	44.8	6.50
D3K LGP	635	25	2.7	4124	29.7	4.30
D4K XL	460	18	2.1	3206	38.6	5.60
D4K LGP	635	25	2.9	4425	29.2	4.24
D5K XL	510	20	2.4	3652	39.1	5.67
D5K LGP	660	26	3.0	4726	31.1	4.52
D6K XL	510	20	2.70	4185	46.7	6.77
(Standard shoe)	560	22	3.00	4650	42.5	6.16
D6K LGP	610	24	3.20	4960	40.7	5.90
(Standard shoe)	760	30	4.00	6200	32.7	4.74
D6N XL (DS)	560	22	2.89	4480	56.2	8.15
(Standard shoe)	610	24	3.15	4880	51.6	7.48
D6N LGP (DS)	865	34	5.39	8358	32.3	4.70
(Standard shoe)	840	33	5.24	8117	33.2	4.80
D6G	457	18	2.43	3766	60.0	8.70
◀	508	20	2.71	4200	54.0	7.83
	560	22	2.98	4619	49.0	7.10
	610	24	3.25	5040	45.0	6.54
D6G Series 2 XL	560	22	2.98	4619	56.0	8.21
	610	24	3.25	5040	52.0	7.53
D6G Series 2 LGP	915	36	5.27	8169	33.0	4.79
	927	36.5	5.34	8277	32.7	4.74
D6R	560	22	2.98	4620	60.3	8.74
	610	24	3.25	5040	55.3	8.02
D6R XL	560	22	3.22	4972	61.4	8.90
	610	24	3.50	5424	56.3	8.16
D6R LGP	915	36	5.99	9288	35.5	5.15
	991	39	6.49	10,062	32.8	4.76
D6R Series 3	508	20	2.70	4200	66.6	9.62
	560	22	2.98	4620	60.3	8.74
	610	24	3.25	5040	55.3	8.02
D6R Series 3 XL	508	20	2.92	4520	67.5	9.79
	560	22	3.22	4972	61.4	8.90
	610	24	3.50	5424	56.3	8.16
D6R Series 3 XW	610	24	3.50	5424	57.9	8.40
	760	30	4.36	6780	46.3	6.72
D6R Series 3 LGP	810	32	5.31	8256	40.0	5.80
	915	36	5.99	9288	35.5	5.15
	991	39	6.49	10,062	32.8	4.76

◀Standard Shoe.

DS — Differential Steer

MODEL	SHOE WIDTH		CONTACT AREA		GROUND PRESSURE	
	mm	in	m <sup>2</sup>	in <sup>2</sup>	kPa	psi
D6T	560	22	2.94	4564	65.0	9.42
	610	24	3.21	4971	59.5	8.63
D6T XL	508	20	2.88	4465	68.8	9.97
	560	22	3.18	4922	62.9	9.13
	610	24	3.46	5361	58.1	8.43
D6T XW	508	20	2.88	4465	69.9	10.13
	610	24	3.46	5361	58.9	8.54
	710	28	4.03	6240	51.0	7.40
	760	30	4.31	6679	48.3	7.01
D6T LGP	610	24	3.97	6146	52.0	7.55
	760	30	4.94	7657	42.2	6.12
	790	31	5.14	7959	40.4	5.86
	915	36	5.95	9219	35.7	5.18
	991	39	6.44	9984	32.4	4.70
D6T XL	508	20	2.88	4465	69.5	10.08
(Tier 4 Interim/	560	22	3.18	4922	63.6	9.23
Stage IIIB)	610	24	3.46	5361	58.8	8.52
D6T XW	508	20	2.88	4465	70.6	10.24
(Tier 4 Interim/	610	24	3.46	5361	59.5	8.63
Stage IIIB)	710	28	4.03	6240	51.6	7.48
	760	30	4.31	6679	48.8	7.08
D6T LGP	610	24	3.97	6146	52.6	7.63
(Tier 4 Interim/	760	30	4.94	7657	42.6	6.19
Stage IIIB)	790	31	5.14	7959	40.8	5.92
	915	36	5.95	9219	36.1	5.24
	991	39	6.44	9984	32.7	4.75

**NOTE:** Ground contact area = width of track shoe  
× length of track on ground × 2.

$$\text{Ground pressure} = \frac{\text{operating weight}}{\text{ground contact area}}$$

**GROUND PRESSURES**

Pressures computed from operating weights given earlier in this section in the specifications tables.

MODEL	SHOE WIDTH		CONTACT AREA		GROUND PRESSURE	
	mm	in	m <sup>2</sup>	in <sup>2</sup>	kPa	psi
D7E <sup>1</sup>	560	22	3.37	5231	74.7	10.83
	610	24	3.68	5698	68.6	9.95
	660	26	3.98	6165	63.4	9.19
D7E LGP <sup>1</sup>	915	36	6.31	9792	43.8	6.34
D7E Tier 4 Interim <sup>1</sup>	560	22	3.37	5231	75.6	10.96
	610	24	3.68	5698	69.4	10.06
	660	26	3.98	6165	64.1	9.30
D7E LGP Tier 4 Interim <sup>1</sup>	915	36	6.31	9792	44.2	6.41
D7G	508	20	2.76	4280	73.0	10.60
	559	22	3.04	4708	66.0	9.60
	610	24	3.31	5136	60.0	8.80
D7G Series 2	560	22	3.04	4708	67.7	9.81
	610	24	3.31	5136	62.2	9.01
D7R Series 2	510	20	2.94	4560	83.4	11.71
	560	22	3.24	5016	76.0	10.69
	610	24	3.53	5472	69.8	9.87
	660	26	3.82	5928	64.0	9.17
D7R Series 2 XR	560	22	3.43	5315	71.5	10.16
	610	24	3.75	5808	65.9	9.37
	660	26	4.06	6282	61.2	8.70
D7R Series 2 LGP	760	30	4.80	7504	55.1	7.74
	915	36	5.82	9029	46.0	6.55
D7R Series 2 LGP ERF*	915	36	6.49	10,060	42.0	6.09

\* Extended track roller frame.  
 ◀ Standard shoe.  
<sup>1</sup> D7E contact area per ISO 16754:2008.

MODEL		SHOE WIDTH		CONTACT AREA		GROUND PRESSURE	
		mm	in	m <sup>2</sup>	in <sup>2</sup>	kPa	psi
D8R/D8T	◀	610	24	3.91	6062	94.9	13.76
		660	26	4.23	6559	87.7	12.71
		710	28	4.55	7056	81.5	11.82
D8R LGP/ D8T LGP		965	38	6.20	9746	54.0	7.82
D9R/D9T		560	22	3.89	6031	124.8	18.10
	◀	610	24	4.24	6569	114.6	16.62
		685	27	4.74	7374	102.0	14.80
		760	30	5.28	8185	92.0	13.34
D10T	◀	610	24	4.74	7321	135.7	19.63
		710	28	5.52	8551	116.2	16.86
		800	31.5	6.22	9635	103.1	14.97
D11T	◀	710	28	6.31	9781	162.4	23.57
		810	32	7.20	11,159	142.4	20.66
		915	36	8.13	12,605	126.0	18.29
D11T CD		810	32	7.20	11,159	153.8	22.32
	◀	915	36	8.13	12,594	136.7	19.76

**NOTE:** Ground contact area = width of track shoe × length of track on ground × 2.

$$\text{Ground pressure} = \frac{\text{operating weight}}{\text{ground contact area}}$$

## EXTREME SLOPE OPERATION

The following table gives the MAXIMUM fore and aft slope on which each tractor will have proper lubrication. Consult Operation & Maintenance Manual (if applicable) for POWER TRAIN fluid level overfill requirements for operation on extreme slopes. Extreme slope operation is anytime the slope exceeds 25° (47%).

The ENGINE should never be overfilled with oil. This may lead to rapid overheating. For extreme slope operation, engine oil should be maintained at the full mark.

**NOTE:** Both ENGINE and POWER TRAIN fluid levels should be checked on level ground before working sidehills and slopes.

### 100% slope capability for all track-type tractor models and pipelayers

When working sidehills and slopes, consideration should be given to the following important points:

- Speed of travel — At higher speeds, inertia forces tend to make the tractor less stable.
- Roughness of terrain or surface — Ample allowance should be made where the terrain or surface is uneven.
- Mounted equipment — Bulldozers, sidebooms, winches, and other mounted equipment cause the tractor to balance differently.
- Nature of surface — New earthen fills may give way with the weight of the tractor. Rocky surfaces may promote side slipping of tractor.
- Track slippage due to excessive loads — This may cause downhill track to “dig in,” increasing angle of tractor.

- Implements hitched to the drawbar — This may decrease weight on uphill track, e.g., logging arch, two-wheel wagon.
- Height of hitch on tractor — When a high drawbar is used the tractor is less stable than with the standard drawbar.
- Width of shoes — Wide track shoes tend to decrease “digging in”, hence tractor is more stable.
- Operated equipment — Be aware of the stability and other performance features of the equipment operated by the tractor.
- Keep all attachments or pulled loads low to the ground for optimum stability.

\*The D7G requires a 23 L (6 gal) transmission overfill for acceptable operation on slopes above 25° (47%).

**NOTE:** Safe operation on steep slopes may require special machine maintenance as well as excellent operator skill and proper equipment for the specific application. Consult Operation & Maintenance Manual (if applicable) for proper fluid level requirements.



# HYDRAULIC CONTROLS

## CONTENTS

Features .....	1-29
Specifications .....	1-30

### Features:

- **Designed and built for specific tractor applications.** Valves and components sized for exacting quality and performance.
- **Job requirements matched** through various arrangements.
- **Hydraulic blade and ripper controls:** Mechanical controls on G Series. Electro hydraulic controls on D6N and D6K (optional on D6T). Pressure compensated on D9R. Pilot operated on D6T and D7R Series 2. Electro hydraulic blade and ripper controls on D7E, D8T, D9T, D10T and D11T.
- **Full flow filters\***... all oil completely filtered.
- **Dual tilt** — standard on D11T and D11T CD, attachment option on D7E, D8R, D8T, D9R, D9T, D10T.

\*Exception — D8R 2-pump.

MODEL	D3K		D4K		D5K	
Mounting Point	Fender		Fender		Fender	
Number of Valves	3 or 4		3 or 4		3 or 4	
Flow at 6890 kPa (1000 psi)	73.5 L/min	19.4 gpm	73.5 L/min	19.4 gpm	73.5 L/min	19.4 gpm
	@ 2150 RPM		@ 2150 RPM		@ 2150 RPM	
Tank Capacity (Oil)	59.5 L	15.7 U.S. gal	59.5 L	15.7 U.S. gal	59.5 L	15.7 U.S. gal
Lift Relief Valve Setting	20 600 kPa	2988 psi	20 600 kPa	2988 psi	20 600 kPa	2988 psi
Weight Installed	39 kg	86 lb*	39 kg	86 lb*	39 kg	86 lb*
	(Four Valves)		(Four Valves)		(Four Valves)	

MODEL	D6K	D6N	D6N**	D6G/ D6G Series 2 XL/ D6G Series 2 LGP
Mounting Point	Under Operators Platform	Right Rear Fender	Right Rear Fender	Fender
Number of Valves	3 or 4	3 or 4	3 or 4	1, 2 or 3
Flow at 6890 kPa (1000 psi)	120 L/min 31.7 gpm	132.5 L/min 35.0 gpm	121 L/min 32 gpm	176 L/min 46 gpm
	@ 2100 RPM	@ 2300 RPM	@ 2200 RPM	@ 1900 RPM
Tank Capacity (Oil)	58 L 15.3 U.S. gal	29.5 L 7.8 U.S. gal	29.5 L 7.8 U.S. gal	47 L 12 U.S. gal
Lift Relief Valve Setting	—	—	—	16 200 kPa 2349 psi
XL and LGP	26 000 kPa 3771 psi	26 200 kPa 3800 psi	25 000 kPa 3600 psi	—
Weight Installed: 3 Valve	30 kg 66 lb	27 kg 59.5 lb	295 kg ** 650 lb	318 kg 700 lb
4 Valve	37 kg 81.6 lb	32 kg 70.5 lb	314 kg ** 703 lb	(Two Valves)

MODEL	D6R (Differential Steer)	D6R Series 3 (Differential Steer)	D6T	D6T VPAT
Mounting Point	Under Operators Platform	Under Operators Platform	Under Operators Platform	Under Operators Platform
Number of Valves	3 or 4	2, 3, 4 or 5	2, 3 or 4	3, 4 or 5
Flow at 6890 kPa (1000 psi)	214 L/min 57 gpm	214 L/min 57 gpm	205 L/min 54 gpm	205 L/min 54 gpm
	@ 2000 RPM	@ 2125 RPM (PMP)	@ 2010 RPM	@ 2010 RPM
Tank Capacity (Oil)	51.5 L 13.6 U.S. gal	47.3 L 12.5 U.S. gal	47.3 L 12.5 U.S. gal	47.3 L 12.5 U.S. gal
Lift Relief Valve Setting	19 305 kPa 2800 psi	19 305 kPa 2800 psi	19 300 kPa 2800 psi	21 550 kPa 3125 psi
Weight Installed	311 kg 686 lb	311 kg 686 lb	Included in Std. Tractor (Two Valves)	Included in Std. Tractor (Three Valves)
	(Two Valves)	(Two Valves)		

MODEL	D7E (Differential Steer)	D7G (173B)	D7G Series 2	D7R Series 2 (Differential Steer)
Mounting Point	Blade Control under Hood; Ripper on Rear	Fender	Fender	Under Operators Platform
Number of Valves	2 Std., 4 w/ripper	1, 2 or 3	1, 2 or 3	2 or 3
Flow at 6890 kPa (1000 psi)	204 L/min 54 gpm	227 L/min 60 gpm	245 L/min 65 gpm	289 L/min 76 gpm
	@ 2124 RPM (PMP)	@ 2080 RPM	@ 2080 RPM	@ 2100 RPM
Tank Capacity (Oil)	76 L 20 U.S. gal	91 L 24 U.S. gal	102 L 27 U.S. gal	54 L 14.3 U.S. gal
Lift Relief Valve Setting	27 600 kPa 4000 psi	15 500 kPa 2250 psi	16 500 kPa 2393 psi	22 750 kPa 3300 psi
Weight Installed	Included in Std. Tractor (Two Valves)	458 kg 1010 lb (Two Valves)	— (Two Valves)	358 kg 784 lb (Two Valves)

\*Hydraulic tank not included.

\*\*Steering system not included.

NOTE: Weight installed, two valves, includes pump, tank with filters, valves, lines, linkage, oil cooler and control levers.

MODEL	D8R	D8T	D9R	D9T
Mounting Point	Under Operators Platform	At Rear Under Fuel Tank	Under Operators Platform	Under Operators Platform
Number of Valves	2 Std. 4 with Ripper◀ Pilot Control System	2 Std. 4 with Ripper Electro/Hydraulic Control System	4 + Dual Tilt (Attach.) Radiator Guard	4 + Dual Tilt (Attach.) Electro/Hydraulic Control System
Flow at 6890 kPa (1000 psi)	240 L/min    63 gpm @ 2100 RPM (PMP)	270 L/min    71.3 gpm @ 2200 RPM	239 L/min    63 gpm @ 1900 RPM	239 L/min    63 gpm @ 1900 RPM
Tank Capacity (Oil)	72 L    19 U.S. gal	75 L    19.8 U.S. gal	77.2 L    20.4 U.S. gal	89 L    23.5 U.S. gal
Lift Relief Valve Setting	24 200 kPa    3500 psi	24 200 kPa    3500 psi	26 200 kPa    3800 psi	26 200 kPa    3800 psi
Weight Installed	Included in Std. Tractor (Two Valves)	Included in Std. Tractor	Included in Std. Tractor (Two Valves)	Included in Std. Tractor

MODEL	D10T	D11T	D11T CD
Mounting Point	Under Operators Platform	Under Operators Platform	Under Operators Platform
Number of Valves	2 Std. 4 with Ripper At Rear Under Fuel Tank 1◀ + Dual Tilt (Attach.) Radiator Guard	4 At Rear Under Fuel Tank 1◀ + Dual Tilt Standard Radiator Guard	4 At Rear Under Fuel Tank 1◀ Dual Tilt Standard Quick Dump Valve Standard Both on Radiator Guard
Flow at 6890 kPa (1000 psi)	450 L/min    118.7 gpm @ 1800 RPM	620 L/min    164 gpm @ 1890 RPM	670 L/min    177 gpm @ 1890 RPM
Tank Capacity (Oil)	131 L    34.6 U.S. gal	223 L    59 U.S. gal	223 L    59 U.S. gal
Lift Relief Valve Setting	Lift: 18 790 kPa    2725 psi Tilt: 20 340 kPa    2950 psi	22 580 kPa    3275 psi 24 132 kPa    3500 psi	24 476 kPa    3550 psi 25 338 kPa    3675 psi
Weight Installed	Included in Std. Tractor (Two Valves)	Included in Std. Tractor	Included in Std. Tractor

◀Ripper valve.

NOTE: Weight installed, two valves, includes pump, tank with filters, valves, lines, linkage, oil cooler and control levers.





# BULLDOZERS

## CONTENTS

Features .....	1-33
Summary of Blade Options .....	1-34
Blade Selection .....	1-35
General Dimensions (Tractor and Blade) .....	1-38
SAE Blade Capacity Definition .....	1-38
Blade Specifications .....	1-39
Estimating Production Off-the-Job .....	1-52
Job Condition Correction Factors .....	1-56
Measuring Production On-the-Job .....	1-57
Work Tools .....	1-57

## Features:

- **Straight Bulldozers** — adjustable pitch angle controls blade penetration.
- **Variable cutting edge Power Angle and Tilt (VPAT)** — blade is available on the D3K, D4K, D5K, D6K, D6N, and D6T. The blade can be mechanically tipped forward for improved penetration or back for more productivity and easier finish grading.
- **Angling Bulldozers** — 25° right/left angling; C-frame allows mounting other tools.
- **Universal Bulldozers** — 25° wings provide increased capacity, less spillage.
- **Semi-Universal Bulldozers** — combines penetration ability of straight blade with increased load capacity provided by short 25° wings.
- **Wheel Dozer blades** are straight design, with hydraulic pitch and tilt control.
- **Box-section construction** on blades adds rigidity and strength.
- **Cutting edges** are heat treated and reversible for extra life.

**CAT BLADES**

**SPECIAL BLADES**

MODEL	S	U	SU	A	FS	LFS	VP	CD	RC	WC	CL	HU	LF	TW	CU	CPB	CB	VR	WCB	CS	WCS	W	
D3K XL							●																
D3K LGP							●																
D4K XL							●																
D4K LGP							●																
D5K XL							●																
D5K LGP							●																
D5E				●																			
D6K XL							●																
D6K LGP							●																
D6N XL			●				●						●										
D6N LGP							●						●										
D6R	●		●	●																			
D6R XL			●	●																			
D6R LGP	●																						
D6R Series 3	●		●	●						●	●		●						●				
D6R Series 3 XL			●	●			●																
D6R Series 3 LGP	●						●			●	●		●						●				
D6R Series 3 XW			●	●			●																
D6T	●		●	●						●	●		●						●				
D6T XL			●	●			●						●										
D6T LGP	●			●			●			●	●		●						●				
D6T XW			●	●			●						●										
D6G	●			●																			
D6G Series 2 XL	●		●	●																			
D6G Series 2 LGP	●																						
D7R Series 2	●	●	●	●						●	●		●	●					●				
D7R Series 2 LGP	●																		●				
D7G	●	●		●										●									
D7G Series 2	●		●	●																			
D8R/D8T		●	●	●					●	●	●		●		●	●			●				
D8R LGP/D8T LGP			●																				
D9R/D9T		●	●						●	●	●		●		●	●	●			●			
D10T		●	●						●	●	●		●		●	●	●						
D11T		●	●						●		●												
D11T CD								●															
814F	●				●						●	●								●	●		
815F					●																		
816F						●							●										●
824G/824H	●									●	●	●										●	
825G					●																		
826G/826H						●							●										●
834G/834H	●	●								●	●									●	●		
836G/836H													●										●

**CAT SUPPLIED**

- S — Straight
- U — Universal
- SU — Semi-Universal
- A — Angling
- FS — Fill Spreading
- LFS — Landfill Spreading
- VP — Variable Pitch, Lower, Angle and Tilt (VPAT)

**SPECIAL SUPPLIED**

- RC — Reclamation U
- WC — Woodchips
- CL — Coal
- HU — Heavy U
- LF — Landfill
- CD — CarryDozer
- TW — Two-Way Dozer
- CU — Cushion Dozer
- CPB — Cushion Push Block
- CB — Coal Bulldozer
- VR — Variable Radius

- WCB — Wood Chip Bulldozer
- CS — Coal Scoop
- WCS — Wood Chip Scoop
- W — W-Blade

**NOTE:** This chart suggests a range of blade options for Cat built machines. It is not totally inclusive of all blades available. For additional information consult your Cat dealer.

## BLADE SELECTION

Properly matching tractor and dozer is a basic requirement for maximizing production. First consider the kind of work the tractor will be doing most of its life. Then evaluate:

- Material to be moved.
- Tractor limitations.

### Materials to be moved

Most materials are dozeable. However, dozer performance will vary with material characteristics such as:

*Particle Size and Shape* — The larger the individual particle size, the harder it is for a cutting edge to penetrate. Particles with sharp edges resist the natural rolling action of a dozer blade. These particles require more horsepower to move than a similar volume of material with rounded edges.

*Voids* — Few voids or the absence of voids means the individual particles have most or all of their surface area in contact with other particles. This forms a bond which must be broken. A well graded material, which lacks voids, is generally heavy, and will be hard to remove from the bank state.

*Water Content* — In most materials the lack of moisture increases the bond between particles and makes the material difficult to remove from the bank state. A high moisture content makes dozing difficult because the material is heavy and requires more force to move. Optimum moisture reduces dust and offers the best condition for dozing ease and operator comfort.

The effect of freezing depends on the moisture content. When frozen, the material's bond strengthens as moisture content increases and temperature decreases. However, freezing a completely dry material does not change its characteristics.

An indication of a blade's ability to penetrate and obtain a blade load is kW per meter (or horsepower per foot) of cutting edge. The higher the kW/meter (HP/foot), the more aggressive the blade. Kilowatt per  $Lm^3$  (horsepower per loose cubic yard) indicates a blade's ability to push material. The higher the kW/ $Lm^3$  (HP/LCY), the greater the blade's potential capability for carrying material at a greater speed.

### Tractor Limitations

The weight and horsepower of the machine determines its ability to push. No tractor can exert more pounds push than the machine itself weighs and its power train can develop. Various terrain and underfoot conditions on the job limit the tractor's ability to use its weight and horsepower. The "approximate coefficient of traction factors" chart in the Tables Section presents these traction factors for common materials. To use the chart, take the total tractor weight (with attachments) times the factor to arrive at the maximum usable push the dozer can exert.

### Production Dozing Tools

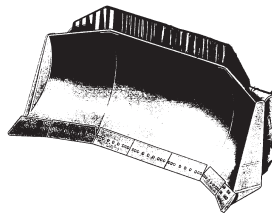

**"U"** — Universal blade — the large wings on this blade include one end bit and at least one section of cutting edge which make it efficient for moving big loads over long distances as in land reclamation, stockpile

work, charging hoppers and trapping for loaders. As this blade has a lower kW/meter (HP/foot) of cutting edge than an "S" or "SU", penetration should not be a prime objective. With a lower kW/ $Lm^3$  (HP/LCY) than an "S" or "SU", this blade is best for lighter or relatively easily dozed material. If equipped with tilt cylinders the U blade can be used to pry out, level, cut ditches and steer the tractor.

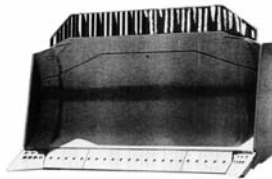

**"SU"** — The Semi-U blade combines the desirable characteristics of S and U-blades into one package. It has increased capacity by the addition of short wings which include only the dozer end

bits. The wings provide improved load retention capabilities while maintaining the blade's ability to penetrate and load quickly in tightly packed materials and to handle a wide variety of materials in production oriented applications. Tilt cylinder(s) increase both the productivity and versatility of this dozer. Equipped with a push plate, it is effectively used for push loading scrapers.

## Bulldozers

### Blade Selection

- Production Dozing Tools
- General Purpose Dozing Tools
- Special Application Dozing Tools

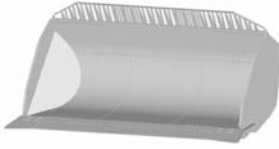

**“CD”** — The CD or Carry-Dozer Blade is available for the D11T CarryDozer only. It is built to the same high standard of structural integrity as the “U” and “SU” Dozers. The CD Blade has

a unique “bucket” shape that allows it to carry several cubic yards or cubic meters of material in the blade. This acts as a disposable counterweight that allows the CarryDozer to push more material per pass than a standard D11T. The CarryDozer will not be as effective as the “U” or “SU” dozer in tightly packed or poorly shot material. It is also more sensitive to the carry-back in sticky materials.

### General Purpose Dozing Tools

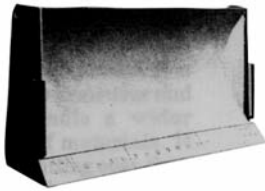

**“S”** — The Straight blade provides excellent versatility. Since it is physically smaller than the SU or U-blade, it is easier to maneuver and can handle a wider range of materials. It has a higher kW/

meter (HP/foot) of cutting edge than the SU or U-blade; consequently, the “S” is more aggressive in penetrating and obtaining a blade load. A tilt cylinder increases both the productivity and versatility of this dozer. With a high kW/Lm<sup>3</sup> (HP/LCY), the S-blade can handle heavy material easily.

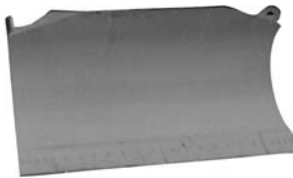

**Power Angle and Tilt blade** — Versatility is its key feature with its ability to perform a variety of site development to general dozing work as well as heavy-

duty applications. Angle and tilt control is with 2 levers on some machines, 1 lever on others.

Variable Power Angle and Tilt (VPAT) blade can be mechanically tipped forward for improved penetration or shedding sticky material and backward for finish grading and improved productivity.

### Special Application Dozing Tools

Caterpillar provides specialty bulldozers for specific applications. The blades are designed to increase production while performing certain tasks. Following are the most popular special applications blades.

### Variable Radius (VR) Blades

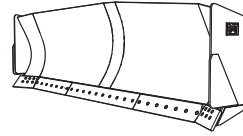

**Variable Radius Semi-U Blades** are excellent tools for land improvement, soil conservation, site development or general construction.

They combine the penetration ability of a Semi-U Blade with the load retention and high capacity of a U-blade.

They provide the aggressive cutting action needed for digging, while having the material retention characteristics needed for moving high volumes over a distance. This is accomplished through a mold-board which varies in radius from the edge to the center. This creates a rolling action in the material being moved, pushing it to the center of the blade for better retention. The extended side wings, angled to thirty degrees, further increase the capacity over a standard blade.

### Cushion Dozers

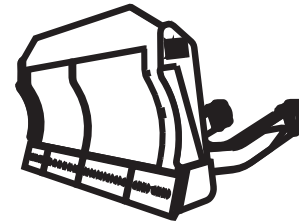

**Cushion Dozers** are designed to push-load wheel-tractor scrapers, or track-type tractors. The heavy-duty design includes reinforcement to transfer machine power without damaging the blade

or the tractor. Blade cylinders are pinned to the C-frame, and the blade height is such that the blade lift cylinders are isolated from damaging forces.

The taller blade allows pushing from a higher position, eliminating blade drag and increasing productivity. The blade curvature is matched to the curve of the Cat Push Block for maximum contact area, preventing the block from riding over the top of the blade. Extended side plates make it easier for operators to “catch” the stinger when repositioning for a new pass. The center of the blade is armored with T-1 plate steel for maximum service life. The narrow width of the cushion blade increases machine maneuverability in congested cuts and reduces the possibility of cutting tires associated with SU and U-blades.

When not push-loading, the dozer can be used for cut maintenance and other general dozing jobs.

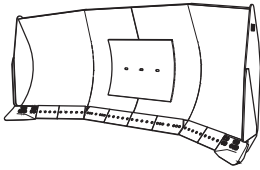

**Coal U-Blades** are designed specifically to move large volumes of coal in coal piles, at powerplants and trans-shipment points. The wing angle of thirty degrees crowds material to the center of the blade, maximizing capacity by minimizing side spill. The moldboard is much higher and wider than standard, specifically to match the material density and loading characteristics of coal. The curve of the moldboard rolls the material forward, enhancing the carrying capacity. With this design, coal-moving capacity can be as much as 200 percent greater than a standard U-blade.

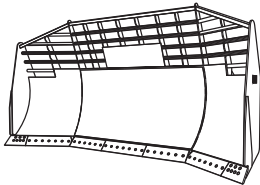

**Landfill U-Blades** provide capacity increases of up to fifty percent over a straight blade. Landfill blades have the height and width to handle large volumes of low-density refuse, but are tough enough to dig and bulldoze ground cover. Vision to the load is provided by areas of screen in the upper blade. Angled wings slice into natural bed earth for trenches or cover material, adding to the versatility in the landfill.

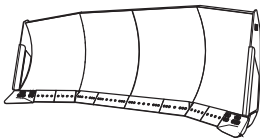

**Reclamation U-Blades** — are purpose-built for reclamation of mine spoil piles. The blade has a larger capacity than a standard U-blade. The wing angle of 28 degrees provides a good balance between load retention and shearing action, keeping the optimal load in front of the blade, but cutting cleanly through the material when necessary.

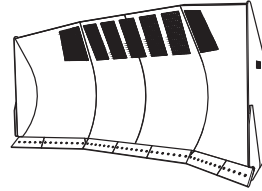

The width of **Woodchip U-Blades** gives operators maximum control and greater confidence, even in steep chip piles. Deep curvature of the moldboard keeps material flowing to live dead chips and optimize production on long pushes. Blade height and wings angled at thirty degrees combine for excellent material retention — giving better production with every pass. An operator visibility window in the top section is standard.

### Multi-Application/Rock and Root Rakes

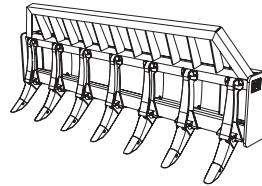

**Multi-Application/Rock and Root Rakes** are perfectly suited for heavy duty land clearing including removal of stumps, large rocks or large trees and for work in clay and other heavy soils. Frames are constructed of high strength steel for longer life. Cast teeth, with replaceable tips, are designed for maximum ground penetration and resistance to shock loading when prying or pushing trees, stumps and rocks. Brush rack is standard and increases height and capacity by as much as 40%.

Rake is a direct replacement for existing blade, and utilizes existing push arms and C-frames.

## Bulldozers

### General Dimensions Key

- Tractor and Blade
- SAE Blade Capacity Definition

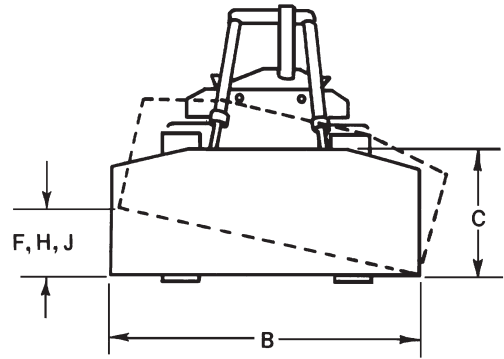
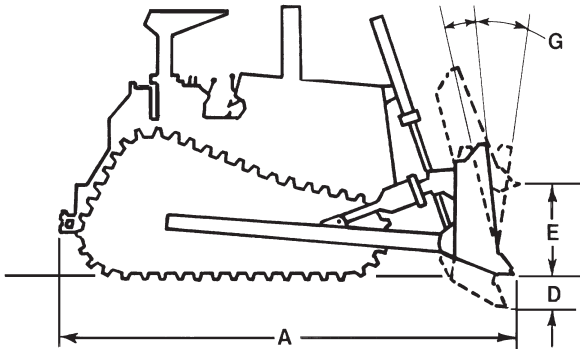

### KEY

- A** Length (Blade Straight)  
Blade:
- B** Width (including standard end bits)
- C** Height
- D** Maximum Digging Depth
- E** Ground Clearance @ Full Lift
- F** Maximum Tilt (Manual)
- G** Maximum Pitch Adjustment
- H** Maximum Hydraulic Tilt
- J** Hydraulic Tilt (manual brace centered)
- K** Push Arm Trunnion Width (to Ball Centers)

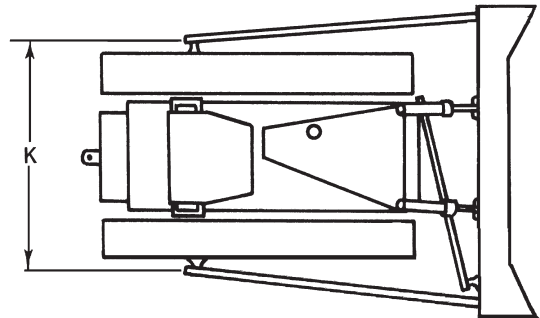

Blade capacities on the following pages are as determined by SAE recommended practice J1265. Capacities are defined as:

$$V_s = 0.8 WH^2.$$

$$V_u = ZH(W-Z) \tan X.$$

Where:  $V_s$  = Capacity of straight or angling blade.

$V_u$  = Capacity of semi-U or full U-blade.

$W$  = Blade width exclusive of end bits.

$H$  = Effective blade height considering tapered top corners, etc.

$Z$  = Wing length measured parallel to blade width @ ground line of cutting edges.

$X$  = Wing angle.

MODEL	D3K				D4K			
	D3K XL		D3K LGP		D4K XL		D4K LGP	
Type	Variable Power Angling and Tilt		Variable Power Angling and Tilt		Variable Power Angling and Tilt		Variable Power Angling and Tilt	
Blade Capacities*	1.52 m <sup>3</sup>	1.99 yd <sup>3</sup>	1.66 m <sup>3</sup>	2.17 yd <sup>3</sup>	1.98 m <sup>3</sup>	2.59 yd <sup>3</sup>	1.85 m <sup>3</sup>	2.42 yd <sup>3</sup>
Weight Shipping** (Dozer)	572 kg	1261 lb	630 kg	1389 lb	642 kg	1415 lb	661 kg	1457 lb
Tractor and Dozer Dimensions:								
A Length (Blade Straight)	4266 mm	168.0"	4255 mm	167.6"	4274 mm	168.3"	4266 mm	168.0"
Length (Blade Angled)	4763 mm	187.5"	4854 mm	191.1"	4795 mm	188.8"	4873 mm	191.8"
Width (Blade Angled)	2417 mm	95.1"	2874 mm	113"	2542 mm	100"	2874 mm	113"
Blade Dimensions:								
B Width (including std. end bits)	2646 mm	104.1"	3149 mm	124.0"	2782 mm	109.5"	3149 mm	124.0"
C Height	910 mm	35.8"	860 mm	33.8"	1010 mm	39.8"	910 mm	35.8"
D Max. Digging Depth	573 mm	22.5"	573 mm	22.5"	572 mm	22.5"	590 mm	23.2"
E Ground Clearance @ Full Lift	730 mm	28.7"	730 mm	28.7"	743 mm	29.3"	708 mm	27.9"
G Max. Pitch Adjustment	52° to 58°		52° to 58°		52° to 58°		52° to 58°	
J Hydraulic Tilt	368 mm	14.4"	438 mm	17.2"	387 mm	15.2"	438 mm	17.2"
Blade Angle	25°		25°		25°		25°	

MODEL	D5K				D6K XL		D6K LGP	
	D5K XL		D5K LGP		VPAT XL		VPAT LGP	
Type	Variable Power Angling and Tilt		Variable Power Angling and Tilt		Variable Pitch Power Angle and Tilt		Variable Pitch Power Angle and Tilt	
Blade Capacities*	2.19 m <sup>3</sup>	2.86 yd <sup>3</sup>	2.34 m <sup>3</sup>	3.06 yd <sup>3</sup>	2.7 m <sup>3</sup>	3.5 yd <sup>3</sup>	2.9 m <sup>3</sup>	3.8 yd <sup>3</sup>
Weight Shipping** (Dozer)	706 kg	1556 lb	728 kg	1605 lb	2173 kg	4791 lb	2231 kg	4919 lb
Tractor and Dozer Dimensions:								
A Length (Blade Straight)	4321 mm	170.1"	4294 mm	169.1"	4980 mm	196"	4980 mm	196"
Length (Blade Angled)	4864 mm	191.5"	4908 mm	193.2"	5564 mm	219"	5620 mm	221"
Width (Blade Angled)	2636 mm	103.8"	2940 mm	115.8"	2817 mm	111"	3118 mm	123"
Width (with C-Frame only)	—		—		2330 mm	92"	2760 mm	109"
Blade Dimensions:								
B Width (including std. end bits)	2782 mm	109.5"	3220 mm	126.7"	3077 mm	121"	3360 mm	132"
C Height	1050 mm	41.3"	1010 mm	39.8"	1140 mm	44.9"	1125 mm	44.3"
D Max. Digging Depth	586 mm	23.1"	572 mm	22.5"	473 mm	18.6"	473 mm	18.6"
E Ground Clearance @ Full Lift	767 mm	30.2"	767 mm	30.2"	943 mm	37.1"	943 mm	37.1"
G Max. Pitch Adjustment	52° to 58°		52° to 58°		55° to 61°		55° to 61°	
H Max. Hydraulic Tilt	—		—		466 mm	18.3"	505 mm	19.9"
J Hydraulic Tilt	402 mm	15.8"	448 mm	17.6"	—		—	
Blade Angle	25°		25°		25°		25°	

\*Blade capacities as determined by SAE J1265.

\*\*Shipping Weight — Total Bulldozer Arrangement includes: Blade, push arms or C-frame, braces, cylinders, lines, trunnions and lift cylinder mountings.



# Bulldozers

## Blade Specifications

- D6N XL   ● D6N LGP   ● D6R
- D6R Series 3   ● D6R Series 3 XL   ● D6R Series 3 XW

MODEL	D6N XL				D6N LGP	
	6SU		6VPAT XL		6VPAT LGP	
Type	Semi-Universal		Variable Pitch Power Angle and Tilt		Variable Pitch Power Angle and Tilt	
Blade Capacities*	4.28 m <sup>3</sup>	5.6 yd <sup>3</sup>	3.18 m <sup>3</sup>	4.16 yd <sup>3</sup>	3.16 m <sup>3</sup>	4.13 yd <sup>3</sup>
Weight, Shipping** (Dozer)	2600 kg	5732 lb	2560 kg	5644 lb	2950 kg	6504 lb
Tractor and Dozer Dimensions:						
A Length (Blade Straight)	5157 mm	203"	4903 mm	193"	5369 mm	211.4"
Length (Blade Angled)	—	—	5527 mm	217.6"	6290 mm	247.6"
Width (Blade Angled)	—	—	2972 mm	117"	3706 mm	146"
Width (with C-Frame only)	—	—	2500 mm	98.4"	3000 mm	118"
Blade Dimensions:						
	(outside mounted)		(inside mounted)		(inside mounted)	
B Width (including std. end bits)	3154 mm	124.2"	3272 mm	128.8"	4080 mm	160.6"
C Height	1244 mm	49"	1195 mm	47.1"	1040 mm	40.9"
D Max. Digging Depth	520 mm	20.5"	538 mm	21.2"	433 mm	17"
E Ground Clearance @ Full Lift	983 mm	38.7"	822 mm	32.4"	1024 mm	40.3"
G Max. Pitch Adjustment	± 5°		54° to 62°		54° to 62°	
H Max. Hydraulic Tilt	665 mm	26.2"	497 mm	19.6"	598 mm	23.5"
Blade Angle	—		25°		25°	

MODEL	D6R				D6R Series 3, D6R Series 3 XL and D6R Series 3 XW			
	6A		6A XL		6A		6A XL	
Gauge	1880 mm	74"	1880 mm	74"	1880 mm	74"	1880 mm	74"
Type	Angling		Angling		Angling		Angling	
Blade Capacities*	3.93 m <sup>3</sup>	5.14 yd <sup>3</sup>	3.93 m <sup>3</sup>	5.14 yd <sup>3</sup>	3.93 m <sup>3</sup>	5.14 yd <sup>3</sup>	3.93 m <sup>3</sup>	5.14 yd <sup>3</sup>
Weight, Shipping** (Dozer)	3138 kg	6904 lb	3109 kg	6839 lb	3138 kg	6904 lb	3109 kg	6839 lb
Tractor and Dozer Dimensions:								
A Length (Blade Straight)	5.22 m	17'1"	5.43 m	17'10"	5.22 m	17'1"	5.43 m	17'10"
Length (Blade Angled)	6.05 m	19'10"	6.26 m	20'6"	6.05 m	19'10"	6.26 m	20'6"
Width (Blade Angled)	3.78 m	12'5"	3.78 m	12'5"	3.78 m	12'5"	3.78 m	12'5"
Width (with C-Frame only)	2.91 m	9'7"	2.98 m	9'10"	2.91 m	9'7"	2.98 m	9'10"
Blade Dimensions:								
B Width (including std. end bits)	4.16 m	13'8"	4.16 m	13'8"	4.16 m	13'8"	4.16 m	13'8"
C Height	1155 mm	3'9.5"	1155 mm	3'9.5"	1155 mm	3'9.5"	1155 mm	3'9.5"
D Max. Digging Depth	506 mm	1'7.9"	524 mm	1'8.6"	506 mm	1'7.9"	524 mm	1'8.6"
E Ground Clearance @ Full Lift	1141 mm	3'8.9"	1205 mm	3'11.4"	1141 mm	3'8.9"	1205 mm	3'11.4"
F Manual Tilt	408 mm	16.1"	408 mm	16.1"	408 mm	16.1"	408 mm	16.1"
H Max. Hydraulic Tilt	408 mm	16.1"	408 mm	16.1"	408 mm	16.1"◀	408 mm	16.1"
Blade Angle	25°		25°		25°		25°	

\* Blade capacities as determined by SAE J1265. Tractor and dozer dimensions variations due to SystemOne™ undercarriage products are negligible. Notice that the capacity of the U-blade is the volume carried by a straight blade of the same dimensions plus the volume included in the "cup" of the U-blade. It is intended for **relative comparisons of dozer sizes**, and not for predicting capacities or productivities in actual field conditions.

\*\* Shipping Weight — Total Bulldozer Arrangement includes: Blade, push arms or C-frame, braces, cylinders, lines, trunnions and lift cylinder mountings.

◀ Attachment includes two cylinders.

Blade Specifications

● D6R Series 3 XL ● D6R Series 3 XW  
● D6R Series 3 LGP ● D6R ● D6R XL ● D6R LGP

MODEL	D6R Series 3 XL, D6R Series 3 XW and D6R Series 3 LGP							
	6PAT XL		6VPAT XL		6VPAT XW		6VPAT LGP	
Gauge	1880 mm	74"	2134 mm	84"	2286 mm	90"	2286 mm	90"
Type	PAT		PAT		PAT		PAT	
Blade Capacities*	4.84 m <sup>3</sup>	6.33 yd <sup>3</sup>	4.2 m <sup>3</sup>	5.5 yd <sup>3</sup>	5.08 m <sup>3</sup>	6.65 yd <sup>3</sup>	4.2 m <sup>3</sup>	5.5 yd <sup>3</sup>
Weight, Shipping** (Dozer)	3246 kg	7150 lb	1615 kg	3560 lb	1656 kg	3650 lb	1642 kg	3620 lb
Tractor and Dozer Dimensions:								
A Length (Blade Straight)	5.44 m	17'10"	5.44 m	17'10"	5.44 m	17'10"	—	
Length (Blade Angled)	5.94 m	19'6"	5.94 m	19'6"	5.94 m	19'6"	—	
Width (Blade Angled)	3.29 m	10'9"	3.75 m	12'4"	3.44 m	11'1"	3.75 m	12'4"
Width (with C-Frame only)	2.49 m	8'2"	—		—		—	
Blade Dimensions:								
B Width (including std. end bits)	3.62 m	11'9"	3.88 m	12'9"	4.16 m	13'8"	4.16 m	13'8"
C Height	1372 mm	54"	1295 mm	51.0"	1295 mm	51.0"	1191 mm	46.9"
D Max. Digging Depth	732 mm	28.7"	737 mm	29.0"	737 mm	29.0"	672 mm	26.5"
E Ground Clearance @ Full Lift	1181 mm	46.5"	1181 mm	46.5"	1181 mm	46.5"	1283 mm	50.5"
F Manual Tilt	—		—		—		—	
G Max. Pitch Adjustment	—		+0° to -3.8°		+0° to -3.8°		+0° to -4.0°	
H Max. Hydraulic Tilt	440 mm	17.3"	502 mm	19.8"	460 mm	18.1"	502 mm	19.8"
Blade Angle	25°		25°		25°		25°	

MODEL	D6R, D6R XL and D6R LGP							
	6S		6SU		6SU XL		6S LGP	
Type	Straight		Semi-Universal		Semi-Universal		Straight	
Blade Capacities*	3.89 m <sup>3</sup>	5.09 yd <sup>3</sup>	5.61 m <sup>3</sup>	7.34 yd <sup>3</sup>	5.61 m <sup>3</sup>	7.34 yd <sup>3</sup>	3.75 m <sup>3</sup>	4.90 yd <sup>3</sup>
Weight, Shipping** (Dozer)	2599 kg	5717 lb	2699 kg	5937 lb	2973 kg	6540 lb	3050 kg	6725 lb
Tractor and Dozer Dimensions:								
A Length (Blade Straight)	5.12 m	16'9"	5.31 m	17'5"	5.55 m	18'2"	5.47 m	17'11"
Blade Dimensions:								
B Width (including std. end bits)	3.36 m	11'0"	3.26 m	10'8"	3.26 m	10'8"	4.04 m	13'3"
C Height	1257 mm	4'1.5"	1411 mm	4'7.6"	1411 mm	4'7.6"	1101 mm	3'7.3"
D Max. Digging Depth	473 mm	18.6"	473 mm	18.6"	459 mm	18.1"	655 mm	2'1.2"
E Ground Clearance @ Full Lift	1104 mm	3'7.5"	1104 mm	3'7.5"	1195 mm	3'11.1"	1083 mm	3'6.6"
F Manual Tilt	689 mm	2'3.1"	670 mm	2'2.4"	670 mm	2'2.4"	632 mm	2'0.9"
G Max. Pitch Adjustment	+5.3 to 4.8°		+5.3 to 4.8°		+5.3 to 4.8°		+5.3 to 4.8°	
H Max. Hydraulic Tilt	764 mm	2'6.1"	743 mm	2'5.3"	743 mm	2'5.3"	701 mm	2'3.6"
J Hydraulic Tilt (Manual Brace Centered)	420 mm	16.5"	408 mm	16.1"	408 mm	16.1"	385 mm	15.2"

\* Blade capacities as determined by SAE J1265.

Notice that the capacity of the U-blade is the volume carried by a straight blade of the same dimensions plus the volume included in the "cup" of the U-blade. It is intended for **relative comparisons of dozer sizes**, and not for predicting capacities or productivities in actual field conditions.

\*\* Shipping Weight — Total Bulldozer Arrangement includes: Blade, push arms or C-frame, braces, cylinders, lines, trunnions and lift cylinder mountings.

# Bulldozers

## Blade Specifications

- D6R Series 3
- D6R Series 3 XL
- D6R Series 3 LGP

MODEL	D6R Series 3, D6R Series 3 XL and D6R Series 3 LGP					
	6S		6SU		6SU XL	
Type	Straight		Semi Universal		Semi Universal	
Blade Capacities*	3.89 m <sup>3</sup>	<b>5.09 yd<sup>3</sup></b>	5.61 m <sup>3</sup>	<b>7.34 yd<sup>3</sup></b>	5.61 m <sup>3</sup>	<b>7.34 yd<sup>3</sup></b>
Weight, Shipping** (Dozer)	2599 kg	<b>5717 lb</b>	2699 kg	<b>5937 lb</b>	2973 kg	<b>6540 lb</b>
Tractor and Dozer Dimensions:						
<b>A</b> Length (Blade Straight)	5.12 m	<b>16'9"</b>	5.31 m	<b>17'5"</b>	5.55 m	<b>18'2"</b>
Blade Dimensions:						
<b>B</b> Width (including std. end bits)	3.36 m	<b>11'0"</b>	3.26 m	<b>10'8"</b>	3.26 m	<b>10'8"</b>
<b>C</b> Height	1257 mm	<b>4'1.5"</b>	1411 mm	<b>4'7.6"</b>	1411 mm	<b>4'7.6"</b>
<b>D</b> Max. Digging Depth	473 mm	<b>18.6"</b>	473 mm	<b>18.6"</b>	459 mm	<b>18.1"</b>
<b>E</b> Ground Clearance @ Full Lift	1104 mm	<b>3'7.5"</b>	1104 mm	<b>3'7.5"</b>	1195 mm	<b>3'11.1"</b>
<b>F</b> Manual Tilt	689 mm	<b>2'3.1"</b>	670 mm	<b>2'2.4"</b>	670 mm	<b>2'2.4"</b>
<b>G</b> Max. Pitch Adjustment	<b>+5.3° to 4.8°</b>		<b>+5.3° to 4.8°</b>		<b>+5.3° to 4.8°</b>	
<b>H</b> Max. Hydraulic Tilt	764 mm	<b>2'6.1"</b>	743 mm	<b>2'5.3"</b>	743 mm	<b>2'5.3"</b>
<b>J</b> Hydraulic Tilt (Manual Brace Centered)	420 mm	<b>16.5"</b>	408 mm	<b>16.1"</b>	408 mm	<b>16.1"</b>

MODEL	D6R Series 3, D6R Series 3 XL and D6R Series 3 LGP					
	6S LGP		6A XW		6SU XW	
Type	Straight		Angling		Semi Universal	
Blade Capacities*	3.70 m <sup>3</sup>	<b>4.83 yd<sup>3</sup></b>	4.3 m <sup>3</sup>	<b>5.63 yd<sup>3</sup></b>	5.62 m <sup>3</sup>	<b>7.4 yd<sup>3</sup></b>
Weight, Shipping** (Dozer)	3050 kg	<b>6725 lb</b>	3260 kg	<b>7180 lb</b>	2950 kg	<b>6500 lb</b>
Tractor and Dozer Dimensions:						
<b>A</b> Length (Blade Straight)	5.47 m	<b>17'11"</b>	5.21 m	<b>17'1"</b>	—	
Length (Blade Angled)	—		5.72 m	<b>18'9"</b>	—	
Blade Dimensions:						
<b>B</b> Width (including std. end bits)	4.04 m	<b>13'3"</b>	4.20 m	<b>13'8"</b>	3.56 m	<b>11'8"</b>
<b>C</b> Height	1101 mm	<b>3'7.3"</b>	1169 mm	<b>3'10"</b>	1412 mm	<b>4'8"</b>
<b>D</b> Max. Digging Depth	655 mm	<b>2'1.2"</b>	500 mm	<b>1'7.7"</b>	459 mm	<b>18.1"</b>
<b>E</b> Ground Clearance @ Full Lift	1083 mm	<b>3'6.6"</b>	1242 mm	<b>4'1"</b>	1195 mm	<b>3'11"</b>
<b>F</b> Manual Tilt	632 mm	<b>2'0.9"</b>	408 mm	<b>16.1"</b>	670 mm	<b>2'2.4"</b>
<b>G</b> Max. Pitch Adjustment	<b>+5.3° to 4.8°</b>		<b>+5.3° to 4.8°</b>		<b>+5.3° to 4.8°</b>	
<b>H</b> Max. Hydraulic Tilt	701 mm	<b>2'3.6"</b>	408 mm	<b>16.1"</b>	743 mm	<b>2'5.3"</b>
<b>J</b> Hydraulic Tilt (Manual Brace Centered)	385 mm	<b>15.2"</b>	408 mm	<b>16.1"</b>	743 mm	<b>2'5.3"</b>

\* Blade capacities as determined by SAE J1265.

Notice that the capacity of the U-blade is the volume carried by a straight blade of the same dimensions plus the volume included in the "cup" of the U-blade. It is intended for **relative comparisons of dozer sizes**, and not for predicting capacities or productivities in actual field conditions.

\*\* Shipping Weight — Total Bulldozer Arrangement includes: Blade, push arms or C-frame, braces, cylinders, lines, trunnions and lift cylinder mountings.

MODEL	D6T					
	6A		6S		6SU	
Gauge	1880 mm	74"	—		—	
Type	Angling		Straight		Semi Universal	
Blade Capacities*	3.93 m <sup>3</sup>	5.14 yd <sup>3</sup>	3.89 m <sup>3</sup>	5.09 yd <sup>3</sup>	5.61 m <sup>3</sup>	7.34 yd <sup>3</sup>
Weight, Shipping** (Dozer)	3138 kg	6904 lb	2599 kg	5717 lb	2699 kg	5937 lb
Tractor and Dozer Dimensions:						
A Length (Blade Straight)	5.22 m	17'1"	5.12 m	16'9"	5.31 m	17'5"
Length (Blade Angled)	6.05 m	19'10"	—	—	—	—
Width (Blade Angled)	3.78 m	12'5"	—	—	—	—
Width (with C-Frame only)	2.91 m	9'7"	—	—	—	—
Blade Dimensions:						
B Width (including std. end bits)	4.16 m	13'8"	3.36 m	11'0"	3.26 m	10'8"
C Height	1155 mm	3'9.5"	1257 mm	4'1.5"	1411 mm	4'7.6"
D Max. Digging Depth	506 mm	1'7.9"	473 mm	1'6.6"	473 mm	1'6.6"
E Ground Clearance @ Full Lift	1141 mm	3'8.9"	1104 mm	3'7.5"	1104 mm	3'7.5"
F Manual Tilt	408 mm	1'4.1"	689 mm	2'3.1"	670 mm	2'2.4"
G Max. Pitch Adjustment	—	—	+5.3° to 4.8°		+5.3° to 4.8°	
H Max. Hydraulic Tilt	408 mm	1'4.1"◀	764 mm	2'6.1"	743 mm	2'5.3"
Blade Angle	—	25°	—	—	—	—
J Hydraulic Tilt (Manual Brace Centered)	—	—	420 mm	1'4.5"	408 mm	1'4.1"
K Push Arm Trunnion Width (to Ball Centers)	2.64 m	8'8"	2.64 m	8'8"	2.64 m	8'8"

\* Blade capacities as determined by SAE J1265. Tractor and dozer dimensions variations due to SystemOne undercarriage products are negligible.

Notice that the capacity of the U-blade is the volume carried by a straight blade of the same dimensions plus the volume included in the "cup" of the U-blade. It is intended for **relative comparisons of dozer sizes**, and not for predicting capacities or productivities in actual field conditions.

\*\* Shipping Weight — Total Bulldozer Arrangement includes: Blade, push arms or C-frame, braces, cylinders, lines, trunnions and lift cylinder mountings.

◀ Attachment includes two cylinders.

MODEL	D6T XL					
	6A XL		6SU XL		6VPAT XL	
Gauge	1880 mm	74"	—		2134 mm	84"
Type	<b>Angling</b>		<b>Semi Universal</b>		<b>PAT</b>	
Blade Capacities*	3.93 m <sup>3</sup>	5.14 yd <sup>3</sup>	5.31 m <sup>3</sup>	6.94 yd <sup>3</sup>	4.73 m <sup>3</sup>	6.19 yd <sup>3</sup>
Weight, Shipping** (Dozer)	3150 kg	6946 lb	2973 kg	6540 lb	1615 kg	3560 lb
Tractor and Dozer Dimensions:						
<b>A</b> Length (Blade Straight)	5.43 m	17'10"	5.5 m	18'2"	5.44 m	17'10"
Length (Blade Angled)	6.26 m	20'6"	—	—	3.54 m	11'7"
Width (Blade Angled)	3.78 m	12'5"	—	—	3.48 m	11'5"
Width (with C-Frame only)	2.98 m	9'10"	—	—	—	—
Blade Dimensions:						
<b>B</b> Width (including std. end bits)	4.16 m	13'8"	3.26 m	10'8"	3.88 m	12'9"
<b>C</b> Height	1155 mm	3'9.5"	1411 mm	4'7.6"	1295 mm	4'3"
<b>D</b> Max. Digging Depth	524 mm	1'8.6"	459 mm	1'6.1"	737 mm	2'5"
<b>E</b> Ground Clearance @ Full Lift	1205 mm	3'11.4"	1195 mm	3'11.1"	1181 mm	3'10.5"
<b>F</b> Manual Tilt	408 mm	1'4.1"	670 mm	2'2.4"	—	—
<b>G</b> Max. Pitch Adjustment	—	—	+5.3° to 4.8°		+0° to -3.8°	
<b>H</b> Max. Hydraulic Tilt	408 mm	1'4.1"	743 mm	2'5.3"	502 mm	1'7.8"
Tilt Right	—	—	—	—	387 mm	15.2"
Tilt Left	—	—	—	—	423 mm	16.65"
Blade Angle	25°		—		25°	
<b>J</b> Hydraulic Tilt (Manual Brace Centered)	—	—	408 mm	1'4.1"	—	—
<b>K</b> Push Arm Trunnion Width (to Ball Centers)	2.64 m	8'8"	2.64 m	8'8"	2.64 m	8'8"

MODEL	D6T XW					
	6A XW		6SU XW		6VPAT XW	
Gauge	—		—		2286 mm	90"
Type	<b>Angling</b>		<b>Semi Universal</b>		<b>PAT</b>	
Blade Capacities*	4.3 m <sup>3</sup>	5.63 yd <sup>3</sup>	5.05 m <sup>3</sup>	6.6 yd <sup>3</sup>	5.08 m <sup>3</sup>	6.65 yd <sup>3</sup>
Weight, Shipping** (Dozer)	3260 kg	7180 lb	2950 kg	6500 lb	1656 kg	3650 lb
Tractor and Dozer Dimensions:						
<b>A</b> Length (Blade Straight)	5.21 m	17'1"	—	—	5.44 m	17'10"
Length (Blade Angled)	5.72 m	18'9"	—	—	5.94 m	19'6"
Width (Blade Angled)	—	—	—	—	3.78 m	12'5"
Blade Dimensions:						
<b>B</b> Width (including std. end bits)	4.50 m	14'9"	3.56 m	11'8"	4.16 m	13'8"
<b>C</b> Height	1169 mm	3'10"	1412 mm	4'8"	1295 mm	4'3"
<b>D</b> Max. Digging Depth	500 mm	1'7.7"	459 mm	1'6.1"	737 mm	2'5"
<b>E</b> Ground Clearance @ Full Lift	1242 mm	4'1"	1195 mm	3'11"	1181 mm	3'10.5"
<b>F</b> Manual Tilt	408 mm	1'4.1"	670 mm	2'2.4"	—	—
<b>G</b> Max. Pitch Adjustment	+5.3° to 4.8°		+5.3° to 4.8°		+0° to -3.8°	
<b>H</b> Max. Hydraulic Tilt	408 mm	1'4.1"	743 mm	2'5.3"	460 mm	1'6.1"
Blade Angle	—		—		25°	
<b>J</b> Hydraulic Tilt (Manual Brace Centered)	408 mm	1'4.1"	743 mm	2'5.3"	—	—
<b>K</b> Push Arm Trunnion Width (to Ball Centers)	2.95 m	9'8"	2.95 m	9'8"	2.95 m	9'8"

\* Blade capacities as determined by SAE J1265.

Notice that the capacity of the U-blade is the volume carried by a straight blade of the same dimensions plus the volume included in the "cup" of the U-blade. It is intended for **relative comparisons of dozer sizes**, and not for predicting capacities or productivities in actual field conditions.

\*\* Shipping Weight — Total Bulldozer Arrangement includes: Blade, push arms or C-frame, braces, cylinders, lines, trunnions and lift cylinder mountings.

MODEL	D6T LGP					
	6A LGP		6S LGP		6VPAT LGP	
Gauge	—		—		2286 mm	90"
Type	Straight		Straight		PAT	
Blade Capacities*	5.22 m <sup>3</sup>	6.82 yd <sup>3</sup>	3.70 m <sup>3</sup>	4.83 yd <sup>3</sup>	4.2 m <sup>3</sup>	5.5 yd <sup>3</sup>
Weight, Shipping** (Dozer)	3712 kg	8185 lb	2840 kg	6262 lb	1642 kg	3620 lb
Tractor and Dozer Dimensions:						
A Length (Blade Straight)	5.82 m	19'1"	5.47 m	17'11"	—	
Width (Blade Angled)	4.63 m	15'2"	—		3.78 m	12'5"
Blade Dimensions:						
B Width (including std. end bits)	5.07 m	16'8"	4.04 m	13'3"	4.16 m	13'8"
C Height	1134 mm	3'9"	1101 mm	3'7.3"	1191 mm	3'10.9"
D Max. Digging Depth	828 mm	2'9"	655 mm	2'1.2"	672 mm	2'2.5"
E Ground Clearance @ Full Lift	1088 mm	3'7"	1083 mm	3'6.6"	1283 mm	4'2.5"
F Manual Tilt	476 mm	1'7"	632 mm	2'0.9"	—	
G Max. Pitch Adjustment	+5.3° to 4.8°		+5.7° to 4.8°		+0° to -4.0°	
H Max. Hydraulic Tilt	476 mm	1'7"	701 mm	2'3.6"	502 mm	1'7.8"
Blade Angle	25°		—		25°	
J Hydraulic Tilt (Manual Brace Centered)	—		385 mm	1'3.2"	—	
K Push Arm Trunnion Width (to Ball Centers)	3.48 m	11'5"	3.48 m	11'5"	—	

MODEL	D7R Series 2					
	7A		7S		7SU	
Type	Angling		Straight		Semi Universal	
Blade Capacities*	3.89 m <sup>3</sup>	5.08 yd <sup>3</sup>	5.16 m <sup>3</sup>	6.75 yd <sup>3</sup>	6.86 m <sup>3</sup>	8.98 yd <sup>3</sup>
Weight, Shipping** (Dozer)	3527 kg	7750 lb	3500 kg	7716 lb	3593 kg	7904 lb
Tractor and Dozer Dimensions:						
A Length (Blade Straight)	6.10 m	20'0"	5.81 m	19'1"	6.03 m	19'9"
Length (Blade Angled)	6.98 m	22'11"	—		—	
Width (Blade Angled)	4.12 m	13'6"	—		—	
Width (with C-Frame only)	3.09 m	10'1"	—		—	
Blade Dimensions:						
B Width (including std. end bits)	4.50 m	14'9"	3.90 m	12'10"	3.69 m	12'1"
C Height	1111 mm	3'7.7"	1363 mm	4'5.7"	1524 mm	5'0"
D Max. Digging Depth	669 mm	2'2.3"	527 mm	1'8.7"	527 mm	1'8.7"
E Ground Clearance @ Full Lift	1115 mm	3'7.9"	1145 mm	3'9.1"	1145 mm	3'9.1"
F Manual Tilt	466 mm	18.3"	—		—	
G Max. Pitch Adjustment	—		+3.1° to 3.9°		+3.1° to 3.9°	
Blade Angle (either side)	25°		—		—	
H Max. Hydraulic Tilt	627 mm	2'0.7"◀	845 mm	2'9.3"	799 mm	2'7.4"
J Hydraulic Tilt (Manual Brace Centered)	—		501 mm	1'7.7"	474 mm	18.6"
K Push Arm Trunnion Width (to Ball Centers)	2.87 m	9'5"	2.87 m	9'5"	2.87 m	9'5"

\* Blade capacities as determined by SAE J1265.

Notice that the capacity of the U-blade is the volume carried by a straight blade of the same dimensions plus the volume included in the "cup" of the U-blade. It is intended for **relative comparisons of dozer sizes**, and not for predicting capacities or productivities in actual field conditions.

\*\* Shipping Weight — Total Bulldozer Arrangement includes: Blade, push arms or C-frame, braces, cylinders, lines, trunnions and lift cylinder mountings.

◀ Attachment includes two cylinders.

# Bulldozers

## Blade Specifications

- D7R Series 2   ● D7R Series 2 LGP
- D7E   ● D7E LGP

MODEL	D7R Series 2 and D7R Series 2 LGP						D7E and D7E LGP	
	7U		7S LGP		7S LGP ERF†		7A	
Type	Universal		Straight		Straight		Angling	
Blade Capacities*	8.34 m <sup>3</sup>	<b>10.91 yd<sup>3</sup></b>	5.89 m <sup>3</sup>	<b>7.7 yd<sup>3</sup></b>	5.89 m <sup>3</sup>	<b>7.7 yd<sup>3</sup></b>	5.15 m <sup>3</sup>	<b>6.75 yd<sup>3</sup></b>
Weight, Shipping** (Dozer)	3920 kg	<b>8624 lb</b>	3732 kg	<b>8229 lb</b>	3732 kg	<b>8210 lb</b>	3790 kg	<b>8330 lb</b>
Tractor and Dozer Dimensions:								
A Length (Blade Straight)	6.27 m	<b>20'7"</b>	5.81 m	<b>19'1"</b>	5.81 m	<b>19'1"</b>	6.20 m	<b>20'4"</b>
Length (Blade Angled)	—	—	—	—	—	—	7.07 m	<b>23'2"</b>
Width (Blade Angled)	—	—	—	—	—	—	4.12 m	<b>13'6"</b>
Width (with C-Frame only)	—	—	—	—	—	—	3.40 m	<b>11'2"</b>
Blade Dimensions:								
B Width (including std. end bits)	3.98 m	<b>13'1"</b>	4.50 m	<b>14'9"</b>	4.50 m	<b>14'9"</b>	4.50 m	<b>14'9"</b>
C Height	1553 mm	<b>5'1.1"</b>	1343 mm	<b>4'4.9"</b>	1343 mm	<b>4'4.9"</b>	1373 mm	<b>4'6"</b>
D Max. Digging Depth	527 mm	<b>1'8.7"</b>	668 mm	<b>2'2.3"</b>	668 mm	<b>2'2.3"</b>	711 mm	<b>2'4"</b>
E Ground Clearance @ Full Lift	1145 mm	<b>3'9.1"</b>	1153 mm	<b>3'9.4"</b>	1153 mm	<b>3'9.4"</b>	1160 mm	<b>3'10"</b>
G Max. Pitch Adjustment	<b>+3.1° to 3.9°</b>		<b>+3.0° to 3.9°</b>		<b>+3.0° to 3.9°</b>		—	
Blade Angle (either side)	—		—		—		<b>25°</b>	
H Max. Hydraulic Tilt	861 mm	<b>2'9.9"</b>	686 mm	<b>2'3"</b>	686 mm	<b>2'3"</b>	685 mm	<b>2'3"</b>
J Hydraulic Tilt (Manual Brace Centered)	511 mm	<b>1'8.1"</b>	426 mm	<b>16.8"</b>	426 mm	<b>16.8"</b>	—	
K Push Arm Trunnion Width (to Ball Centers)	—		—		—		—	
STD	2.87 m	<b>9'5"</b>	—	—	—	—	2.81 m	<b>9'2"</b>
LGP	—	—	3.37 m	<b>11'1"</b>	3.37 m	<b>11'1"</b>	2.81 m	<b>9'2"</b>

MODEL	D7E and D7E LGP							
	7S		7SU		7U		7S LGP	
Type	Straight		Semi Universal		Universal		Straight	
Blade Capacities*	5.16 m <sup>3</sup>	<b>6.75 yd<sup>3</sup></b>	6.86 m <sup>3</sup>	<b>8.98 yd<sup>3</sup></b>	8.34 m <sup>3</sup>	<b>10.91 yd<sup>3</sup></b>	5.89 m <sup>3</sup>	<b>7.70 yd<sup>3</sup></b>
Weight, Shipping** (Dozer)	3504 kg	<b>7709 lb</b>	3832 kg	<b>8431 lb</b>	3806 kg	<b>8373 lb</b>	3970 kg	<b>8734 lb</b>
Tractor and Dozer Dimensions:								
A Length (Blade Straight)	5.92 m	<b>19'5"</b>	6.17 m	<b>20'3"</b>	6.38 m	<b>20'11"</b>	6.28 m	<b>20'7"</b>
Blade Dimensions:								
B Width (including std. end bits)	3.90 m	<b>12'10"</b>	3.71 m	<b>12'2"</b>	3.99 m	<b>13'1"</b>	4.55 m	<b>14'1"</b>
C Height	1363 mm	<b>4'6"</b>	1524 mm	<b>5'0"</b>	1553 mm	<b>5'1"</b>	1343 mm	<b>4'5"</b>
D Max. Digging Depth	568 mm	<b>1'10"</b>	568 mm	<b>1'10"</b>	568 mm	<b>1'10"</b>	650 mm	<b>2'2"</b>
E Ground Clearance @ Full Lift	1144 mm	<b>3'9"</b>	1144 mm	<b>3'9"</b>	1144 mm	<b>3'9"</b>	1272 mm	<b>4'2"</b>
G Max. Pitch Adjustment	<b>52° to 58°</b>		<b>52° to 58°</b>		<b>52° to 58°</b>		<b>54° to 60°</b>	
H Max. Hydraulic Tilt	813 mm	<b>2'8"</b>	760 mm	<b>2'6"</b>	821 mm	<b>2'8"</b>	778 mm	<b>2'7"</b>
J Hydraulic Tilt (Manual Brace Centered)	524 mm	<b>1'9"</b>	489 mm	<b>1'7"</b>	550 mm	<b>1'10"</b>	495 mm	<b>1'7"</b>
K Push Arm Trunnion Width (to Ball Centers)	2.81 m	<b>9'2"</b>	2.81 m	<b>9'2"</b>	2.81 m	<b>9'2"</b>	3.35 m	<b>11'0"</b>

\* Blade capacities as determined by SAE J1265.

Notice that the capacity of the U-blade is the volume carried by a straight blade of the same dimensions plus the volume included in the "cup" of the U-blade. It is intended for **relative comparisons of dozer sizes**, and not for predicting capacities or productivities in actual field conditions.

\*\* Shipping Weight — Total Bulldozer Arrangement includes: Blade, push arms or C-frame, braces, cylinders, lines, trunnions and lift cylinder mountings.

† Extended track roller frame.

MODEL	D8R/D8T							
	8A		8SU		8U		8SU LGP	
Type	<b>Angling</b>		<b>Semi-U</b>		<b>Universal</b>		<b>Semi-U</b>	
Blade Capacities*	4.7 m <sup>3</sup>	<b>6.1 yd<sup>3</sup></b>	8.7 m <sup>3</sup>	<b>11.4 yd<sup>3</sup></b>	11.7 m <sup>3</sup>	<b>15.3 yd<sup>3</sup></b>	8.5 m <sup>3</sup>	<b>11.1 yd<sup>3</sup></b>
Weight, Shipping** (Dozer)	5459 kg	<b>12,009 lb</b>	4789 kg	<b>10,557 lb</b>	5352 kg	<b>11,800 lb</b>	4850 kg	<b>10,694 lb</b>
Tractor and Dozer Dimensions:								
<b>A</b> Length (Blade Straight)	6.57 m	<b>21'7"</b>	6.39 m	<b>21'0"</b>	6.79 m	<b>22'3"</b>	6281 mm	<b>20'7"</b>
Length (Blade Angled)	7.62 m	<b>25'0"</b>	—	—	—	—	—	—
Width (Blade Angled)	4.52 m	<b>14'10"</b>	—	—	—	—	—	—
Width (with C-Frame only)	3.38 m	<b>11'1"</b>	—	—	—	—	—	—
Blade Dimensions:								
<b>B</b> Width (including std. end bits)	4.99 m	<b>16'4"</b>	3.94 m	<b>12'11"</b>	4.26 m	<b>14'0"</b>	4400 mm	<b>14'5"</b>
<b>C</b> Height	1174 mm	<b>3'10.2"</b>	1690 mm	<b>5'6.5"</b>	1740 mm	<b>5'8.5"</b>	1612 mm	<b>5'3"</b>
<b>D</b> Max. Digging Depth	628 mm	<b>2'0.7"</b>	575 mm	<b>22.6"</b>	575 mm	<b>22.6"</b>	582 mm	<b>22.9"</b>
<b>E</b> Ground Clearance @ Full Lift	1308 mm	<b>4'3.5"</b>	1225 mm	<b>48.2"</b>	1225 mm	<b>48.2"</b>	1231 mm	<b>4'0"</b>
<b>G</b> Max. Pitch Adjustment	—	—	<b>+3.0° to 2.9°</b>		<b>+3.0° to 2.9°</b>		—	—
Blade Angle (either side)	—	<b>25°</b>	—	—	—	—	—	—
<b>H</b> Max. Hydraulic Tilt	729 mm	<b>2'4.7"◀</b>	883 mm	<b>34.8"</b>	954 mm	<b>37.5"</b>	914 mm	<b>3'0"</b>
<b>J</b> Hydraulic Tilt (Manual Brace Centered)	—	—	596 mm	<b>23"</b>	644 mm	<b>25"</b>	—	—
<b>K</b> Push Arm Trunnion Width (to Ball Centers)	2.98 m	<b>9'9"</b>	2.98 m	<b>9'9"</b>	2.98 m	<b>9'9"</b>	—	—
Maximum Track Width Permitted	712 mm	<b>2'4"</b>	711 mm	<b>2'4"</b>	711 mm	<b>2'4"</b>	965 mm	<b>38"</b>
Dual Tilt Option								
<b>G</b> Dual Pitch Adj.	—	—	<b>±4.6°</b>		<b>±4.6°</b>		—	—
<b>H</b> Dual Max. Hyd. Tilt	—	—	879 mm	<b>34.5"</b>	950 mm	<b>37.3"</b>	—	—

\* Blade capacities as determined by SAE J1265.

Notice that the capacity of the U-blade is the volume carried by a straight blade of the same dimensions plus the volume included in the "cup" of the U-blade. It is intended for **relative comparisons of dozer sizes**, and not for predicting capacities or productivities in actual field conditions.

\*\* Shipping Weight — Total Bulldozer Arrangement includes: Blade, push arms or C-frame, braces, cylinders, lines, trunnions and lift cylinder mountings.

◀ Attachment includes two cylinders.



MODEL	D9R/D9T			
	9SU		9U	
Type	<b>Semi-U</b>		<b>Universal</b>	
Blade Capacities*	13.5 m <sup>3</sup>	17.7 yd <sup>3</sup>	16.4 m <sup>3</sup>	21.4 yd <sup>3</sup>
Weight, Shipping** (Dozer)	6543 kg	14,425 lb	7134 kg	15,727 lb
Tractor and Dozer Dimensions:				
<b>A</b> Length (Blade Straight)	6.84 m	22'5"	7.18 m	23'7"
Blade Dimensions:				
<b>B</b> Width (including std. end bits)	4.31 m	14'2"	4.65 m	15'3"
<b>C</b> Height	1934 mm	6'4.1"	1934 mm	6'4.1"
<b>D</b> Max. Digging Depth	606 mm	1'11.9"	606 mm	1'11.9"
<b>E</b> Ground Clearance @ Full Lift	1422 mm	4'8"	1422 mm	4'8"
<b>G</b> Max. Pitch Adjustment	+3.4° to 2.9°		+3.4° to 2.9°	
<b>H</b> Max. Hydraulic Tilt	940 mm	3'1"	1014 mm	3'3.9"
<b>J</b> Hydraulic Tilt (Manual Brace Centered)	570 mm	1'10.4"	616 mm	2'0.3"
<b>K</b> Push Arm Trunnion Width (to Ball Centers)	3.17 m	10'3"	3.17 m	10'3"
Maximum Track Width Permitted	762 mm	2'6"	762 mm	2'6"
Dual Tilt Option				
<b>G</b> Dual Pitch Adj.	+4.8° to 5.2°		+4.8° to 4.9°	
<b>H</b> Dual Max. Hyd. Tilt	1139 mm	3'8.8"	1231 mm	4'0.5"

\* Blade capacities as determined by SAE J1265.

Notice that the capacity of the U-blade is the volume carried by a straight blade of the same dimensions plus the volume included in the "cup" of the U-blade. It is intended for **relative comparisons of dozer sizes**, and not for predicting capacities or productivities in actual field conditions.

\*\* Shipping Weight — Total Bulldozer Arrangement includes: Blade, push arms or C-frame, braces, cylinders, lines, trunnions and lift cylinder mountings.

MODEL	D10T				D11T					
	10SU		10U		11SU		11U		11 CD	
Type	Semi-U		Universal		Semi-U		Universal		CarryDozer	
Blade Capacities*	18.5 m <sup>3</sup>	24.2 yd <sup>3</sup>	22.0 m <sup>3</sup>	28.7 yd <sup>3</sup>	27.2 m <sup>3</sup>	35.5 yd <sup>3</sup>	34.4 m <sup>3</sup>	45.0 yd <sup>3</sup>	43.6 m <sup>3</sup>	57.0 yd <sup>3</sup>
Weight, Shipping**										
Standard Dozer	10 229	22,550	10 784	23,775	14 813	32,658	17 296	38,131	23 600	51,920
	kg	lb	kg	lb	kg	lb	kg	lb	kg	lb
Abrasion Dozer	11 069	24,403	12 413	27,366	16 192	35,698	18 823	41,498	—	
	kg	lb	kg	lb	kg	lb	kg	lb		
Tractor and Dozer Dimensions:										
A Length	7.50 m	24'7"	7.75 m	25'5"	8.38 m	27'6"	8.83 m	28'11"	8.34 m	26'8"
Width	4.86 m	15'11"	5.26 m	17'3"	5.60 m	18'4"	6.35 m	20'10"	6.71 m	22'0"
Blade Dimensions:										
B Width (including std. end bits)	4.86 m	15'11"	5.26 m	17'3"	5.60 m	18'4"	6.36 m	20'10"	6.71 m	22'0"
C Height	2.12 m	6'11"	2.12 m	6'11"	2.77 m	9'1"	2.77 m	9'1"	2.74 m***	9'0"****
D Max. Digging Depth	674 mm	2'2.5"	674 mm	2'2.5"	766 mm	2'6.2"	766 mm	2'6.2"	688 mm	2'3"
E Ground Clearance @ Full Lift	1497 mm	4'10.9"	1497 mm	4'10.9"	1533 mm	5'0.4"	1533 mm	5'0.4"	1850 mm	6'1"
G Max. Pitch Adjustment	+1.7° to 2.3°		+1.7° to 2.3°		+2.1° to 2.2°		+2.1° to 2.2°		—	
H Max. Hydraulic Tilt	993 mm	3'3.1"	1074 mm	3'6.3"	1184 mm	3'10.6"	1344 mm	4'4.9"	1800 mm	5'11"
J Hydraulic Tilt (Manual Brace Centered)	722 mm	2'4.4"	782 mm	2'6.8"	886 mm	2'10.9"	1006 mm	3'3.6"	—	
K Push Arm Trunnion Width (to Ball Centers)	3.60 m	11'10"	3.60 m	11'10"	4.18 m	13'9"	4.18 m	13'9"	4.18 m	13'9"
Maximum Track Width Permitted	762 mm	2'6"	762 mm	2'6"	914 mm	3'0"	914 mm	3'0"	914 mm	3'0"
Dual Tilt Option					+7.5° to 7.6° or		+7.5° to 7.6° or			
G Dual Pitch Adjustment	+5.2° to 5.5°		+5.2° to 5.5°		+0° to 13°		+0° to 13°		+47.8° to 10.4°	
H Dual Max. Hyd. Tilt	1441 mm	4'8.7"	1560 mm	5'1.4"	1706 mm	5'7.2"	1938 mm	6'4.3"	—	

\*Blade capacities as determined by SAE J1265.

Notice that the capacity of the U-blade is the volume carried by a straight blade of the same dimensions plus the volume included in the "cup" of the U-blade. It is intended for **relative comparisons of dozer sizes**, and not for predicting capacities or productivities in actual field conditions.

\*\*Shipping Weight — Total Bulldozer Arrangement includes: Blade, push arms or C-frame, braces, cylinders, lines, trunnions and lift cylinder mountings.

\*\*\*Blade height with cutting edge at 53°.

All dimensions are approximate.

MODEL	D6G/D6G Series 2 XL				D6G Series 2 XL		D6G Series 2 LGP	
	6A		6S		6SU ▶		6S	
Type	<b>Angling</b>		<b>Straight</b>		<b>Semi-U</b>		<b>Straight</b>	
Blade Capacities	2.40 m <sup>3</sup>	<b>3.14 yd<sup>3</sup></b>	3.27 m <sup>3</sup>	<b>4.28 yd<sup>3</sup></b>	3.80 m <sup>3</sup>	<b>4.96 yd<sup>3</sup></b>	3.2 m <sup>3</sup>	<b>4.2 yd<sup>3</sup></b>
Weight, Shipping* (Dozer)	2325 kg	<b>5126 lb</b>	1998 kg	<b>4405 lb</b>	2460 kg	<b>5423 lb</b>	1997 kg	<b>4403 lb</b>
Tractor and Dozer Dimensions:								
<b>A</b> Length (Blade Straight)	5.15 m	<b>16'11"</b>	5.07 m	<b>16'8"</b>	5.13 m	<b>16'10"</b>	5.16 m	<b>16'11"</b>
Length (Blade Angled)	5.91 m	<b>19'5"</b>	—	—	—	—	—	—
Width (Blade Angled)	3.52 m	<b>11'6"</b>	—	—	—	—	—	—
Width (with C-frame only)	2.85 m	<b>9'4"</b>	—	—	—	—	—	—
Blade Dimensions:								
<b>B</b> Width (including std. end bits)	3.88 m	<b>12'9"</b>	3.23 m	<b>10'7"</b>	3.20 m	<b>10'6"</b>	3.71 m	<b>12'2"</b>
<b>C</b> Height	924 mm	<b>3'0.4"</b>	1126 mm	<b>3'8.3"</b>	1235 mm	<b>4'0.6"</b>	1035 mm	<b>3'4.7"</b>
<b>D</b> Max. Digging Depth	444 mm	<b>17.5"</b>	474 mm	<b>18.7"</b>	472 mm	<b>18.6"</b>	494 mm	<b>19.5"</b>
<b>E</b> Ground Clearance @ Full Lift	908 mm	<b>35.7"</b>	907 mm	<b>2'11.7"</b>	915 mm	<b>3'0"</b>	1089 mm	<b>3'6.9"</b>
<b>F</b> Manual Tilt	367 mm	<b>14.4"</b>	679 mm	<b>2'2.7"</b>	680 mm	<b>2'2.8"</b>	697 mm	<b>2'3.4"</b>
Blade Angle (either side)	<b>25°</b>		—	—	—	—	—	—
<b>H</b> Max. Hydraulic Tilt	—	—	810 mm	<b>2'8"</b>	810 mm	<b>2'7.9"</b>	857 mm	<b>2'9.7"</b>
<b>J</b> Hydraulic Tilt (Manual Brace Centered)	—	—	467 mm	<b>18.4"</b>	465 mm	<b>18.3"</b>	367 mm	<b>14.4"</b>

\*Shipping Weight — Total Bulldozer Arrangement includes: Blade, push arms or C-frame, braces, cylinders, lines, trunnions and lift cylinder mountings. Notice that the capacity of the SU-blade is the volume carried by a straight blade of the same dimensions plus the volume included in the "cup" of the SU-blade. It is intended for **relative comparisons of dozer sizes**, and not for predicting capacities or productivities in actual field conditions.

▶Caterpillar Custom Product.

MODEL	D7G/D7G Series 2				D7G Series 2	
	7A		7S		7SU	
Type	<b>Angling</b>		<b>Straight</b>		<b>Semi-U Blade</b>	
Blade Capacities*	2.9 m <sup>3</sup>	<b>3.8 yd<sup>3</sup></b>	4.2 m <sup>3</sup>	<b>5.5 yd<sup>3</sup></b>	5.75 m <sup>3</sup>	<b>7.53 yd<sup>3</sup></b>
Weight, Shipping** (Dozer)	3227 kg	<b>7115 lb</b>	3475 kg	<b>7660 lb</b>	2293 kg	<b>5054 lb</b>
Tractor and Dozer Dimensions:						
<b>A</b> Length (Blade Straight)	5.49 m	<b>18'0"</b>	5.30 m	<b>17'5"</b>	5.63 m	<b>18'6"</b>
Length (Blade Angled)	6.35 m	<b>20'10"</b>	—	—	—	—
Width (Blade Angled)	3.86 m	<b>12'8"</b>	—	—	—	—
Width (with C-Frame only)	3.12 m	<b>10'3"</b>	—	—	—	—
Blade Dimensions:						
<b>B</b> Width (including std. end bits)	4.26 m	<b>14'0"</b>	3.65 m	<b>12'0"</b>	3.46 m	<b>11'4"</b>
<b>C</b> Height	960 mm	<b>3'1.8"</b>	1274 mm	<b>4'2.1"</b>	1380 mm	<b>4'6"</b>
<b>D</b> Max. Digging Depth	468 mm	<b>18.4"</b>	438 mm	<b>17.2"</b>	438 mm	<b>17.2"</b>
<b>E</b> Ground Clearance @ Full Lift	1206 mm	<b>3'11.5"</b>	1188 mm	<b>3'10.8"</b>	721 mm	<b>2'4.4"</b>
<b>G</b> Max. Pitch Adjustment	—	—	<b>+5.2° to 3.0°</b>		<b>+5.2° to 3.0°</b>	
Blade Angle (either side)		<b>25°</b>	—	—	—	—
<b>H</b> Max. Hydraulic Tilt	300 mm	<b>11.8"◀</b>	721 mm	<b>2'4.4"</b>	721 mm	<b>2'4.4"</b>
<b>J</b> Hydraulic Tilt (Manual Brace Centered)		—	505 mm	<b>1'7.9"</b>	505 mm	<b>1'7.9"</b>

\* Blade capacities as determined by SAE J1265.

\*\* Shipping Weight — Total Bulldozer Arrangement includes: Blade, push arms or C-frame, braces, cylinders, lines, trunnions and lift cylinder mountings.

◀ Attachment includes two cylinders.

**BULLDOZER PRODUCTION OFF-THE-JOB**

You can estimate bulldozer production using the production curves that follow and the correction factors that are applicable. Use this formula:

$$\text{Production (Lm}^3\text{/hr)} = \frac{\text{Maximum production}}{\text{(LCY/hr)}} \times \frac{\text{Correction factors}}$$

The bulldozer production curves give maximum uncorrected production for universal, semi-universal, and straight blades and are based on the following conditions:

1. 100% efficiency (60 minute hour — level cycle).
2. Power shift machines with 0.05 min. fixed times.
3. Machine cuts for 15 m (50 feet), then drifts blade load to dump over a high wall. (Dump time — 0 sec.)
4. Soil density of 1370 kg/Lm<sup>3</sup> (2300 lb/LCY).
5. Coefficient of traction:
  - a. Track machines — 0.5 or better
  - b. Wheel machines — 0.4 or better
6. Hydraulic controlled blades used.
7. Dig 1F\*\*  
Carry 2F\*\*  
Return 2R\*\*

To obtain estimated production in bank cubic meters or bank cubic yards, appropriate load factor from the Tables section should be applied to the corrected production as calculated above.

$$\text{Production Bm}^3\text{/hr} = \frac{\text{Lm}^3\text{/hr} \times \text{LF}}{\text{(BCY/h)} \times \text{LF}}$$

\*Coefficient of traction assumed to be at least 0.4. While poor traction affects both track and wheel vehicles, causing them to take smaller blade loads, wheeled units are affected more severely and production falls much more rapidly. While no fixed rules can predict this production loss, a rough rule of thumb is that wheel dozer production falls off 4% for each one-hundredth decrease in coefficient of traction below 0.40. If, for example, coefficient of traction is 0.30, the difference is ten-hundredths (0.10), and production is 60% (10 × 4% = 40% decrease).

\*\*This gear sequence is based on level to downhill terrain, light to medium density material, and no blade extensions such as spill plates, rock guards, etc. Exceeding these conditions may require carry in 1F, but productivity should equal or exceed “standard conditions” due to the larger loads that can be carried in 1F.

ESTIMATED DOZING PRODUCTION • Universal Blades • D7G through D11T CD

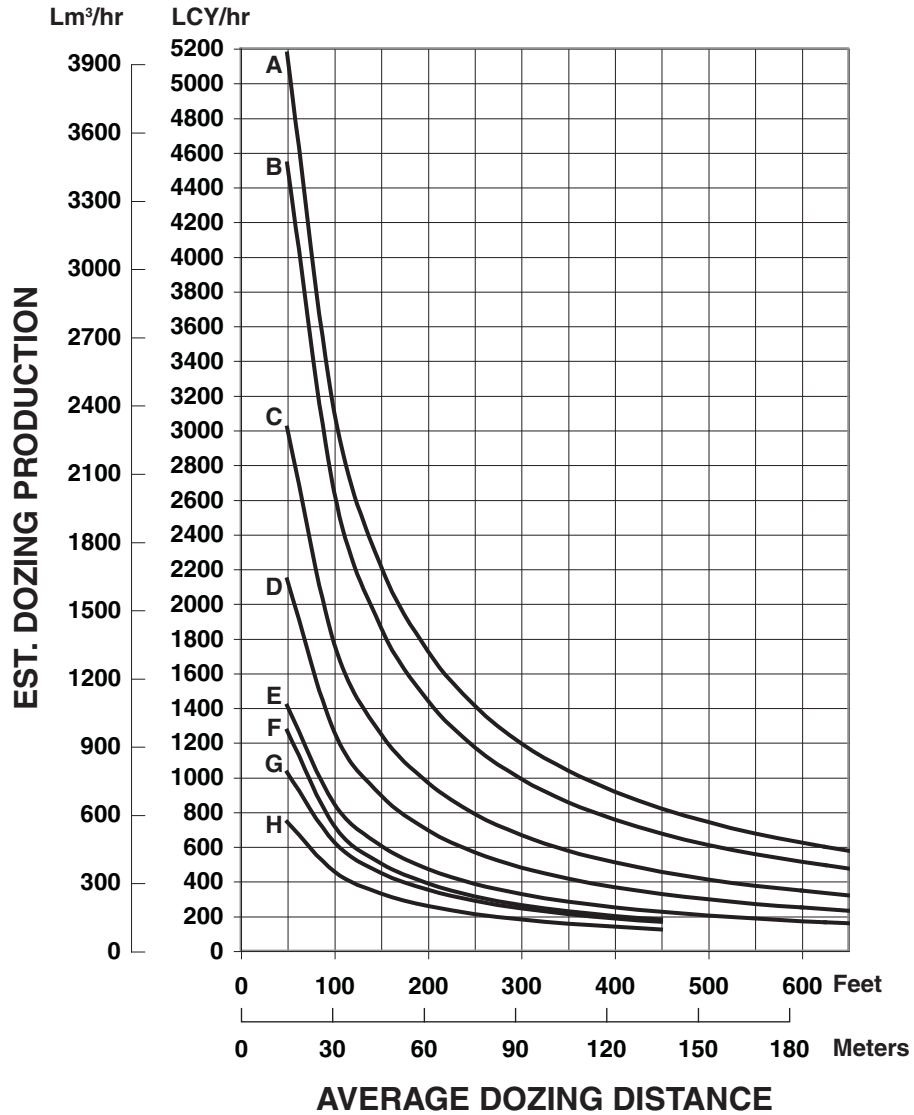

KEY

- A — D11T CD
- B — D11T
- C — D10T
- D — D9T
- E — D8T
- F — D7E
- G — D7R Series 2
- H — D7G

NOTE: This chart is based on numerous field studies made under varying job conditions. Refer to correction factors following these charts.

**ESTIMATED DOZING PRODUCTION ● Semi-Universal Blades ● D6N through D11T**

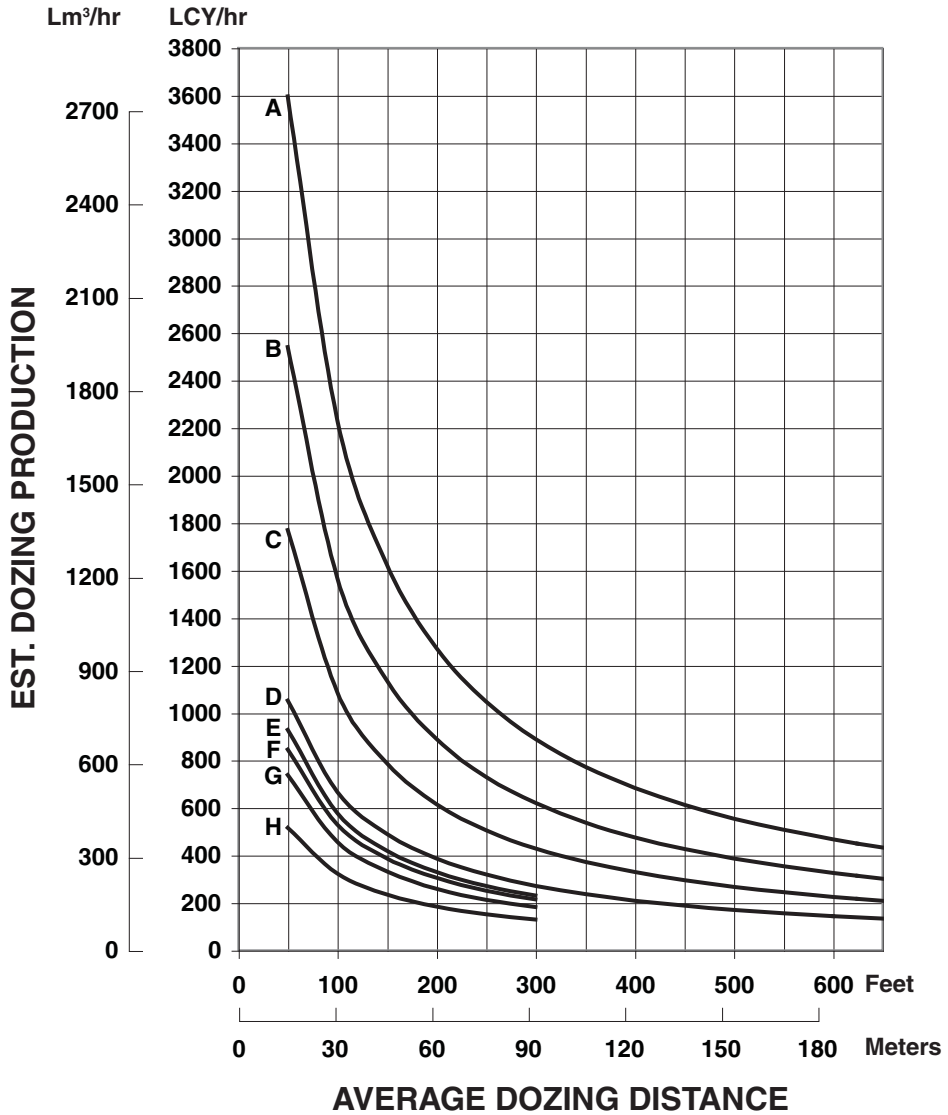

**KEY**

- A — D11T
- B — D10T
- C — D9T
- D — D8T
- E — D7E
- F — D7R Series 2
- G — D6T
- H — D6N

**NOTE:** This chart is based on numerous field studies made under varying job conditions. Refer to correction factors following these charts.

ESTIMATED DOZING PRODUCTION ● Straight Blades ● D6T through D7R Series 2

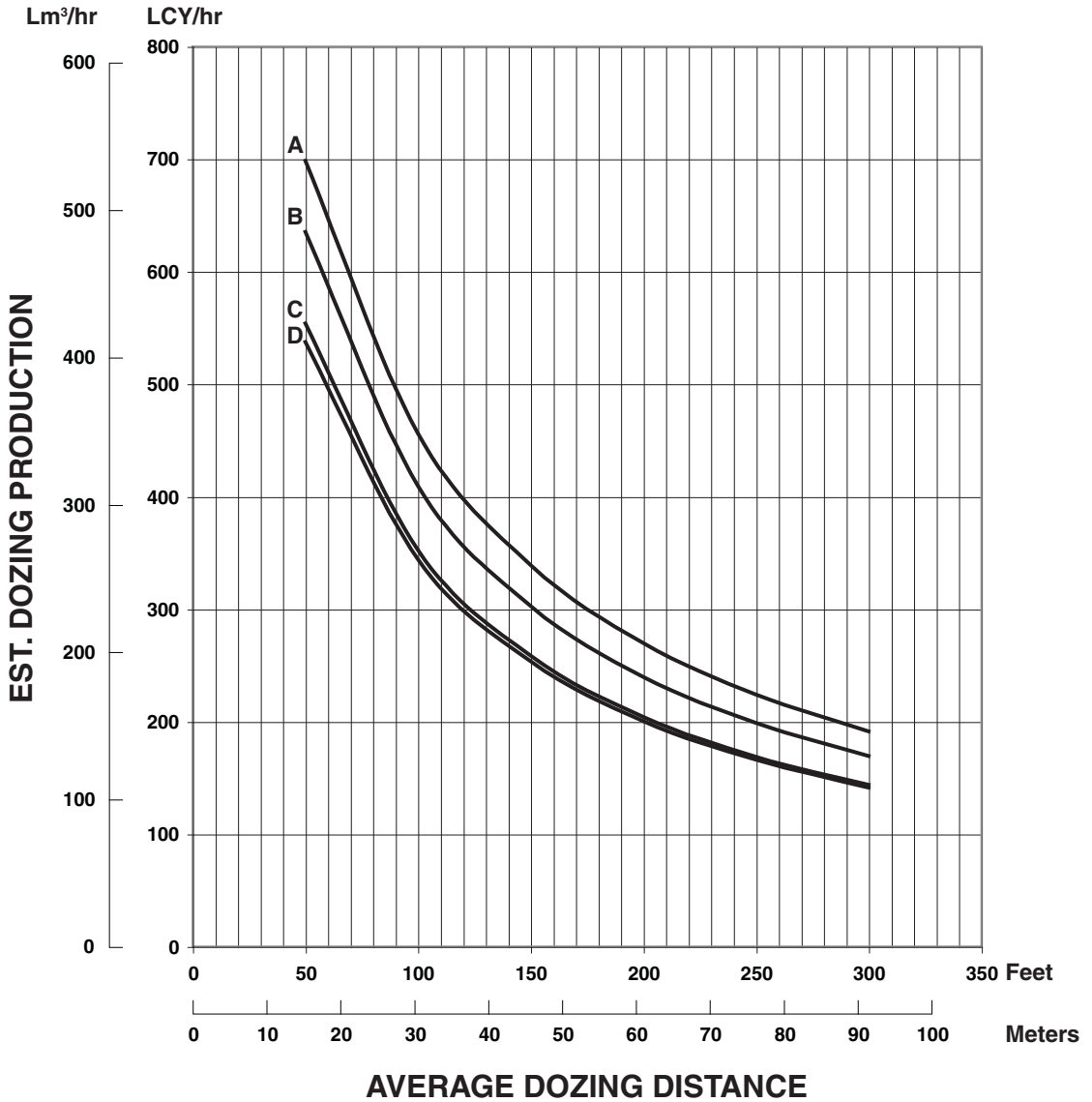

KEY

- A — D7E
- B — D7R Series 2
- C — D6T
- D — D7G

**NOTE:** This chart is based on numerous field studies made under varying job conditions. Refer to correction factors following these charts.



**JOB CONDITION CORRECTION FACTORS**

	TRACK-TYPE TRACTOR
<b>OPERATOR —</b>	
Excellent	1.00
Average	0.75
Poor	0.60
<b>MATERIAL —</b>	
Loose stockpile	1.20
Hard to cut; frozen —	
with tilt cylinder	0.80
without tilt cylinder	0.70
Hard to drift; “dead” (dry, non-cohesive material) or very sticky material	0.80
Rock, ripped or blasted	0.60-0.80
<b>SLOT DOZING</b>	
<b>SIDE BY SIDE DOZING</b>	1.15-1.25
<b>VISIBILITY —</b>	
Dust, rain, snow, fog or darkness	0.80
<b>JOB EFFICIENCY —</b>	
50 min/hr	0.83
40 min/hr	0.67
<b>BULLDOZER*</b>	
Adjust based on SAE capacity relative to the base blade used in the Estimated Dozing Production graphs.	
<b>GRADES —</b> See following graph.	

\*NOTE: Angling blades and cushion blades are not considered production dozing tools. Depending on job conditions, the A-blade and C-blade will average 50-75% of straight blade production.

**% Grade vs. Dozing Factor**

(-) Downhill  
 (+) Uphill

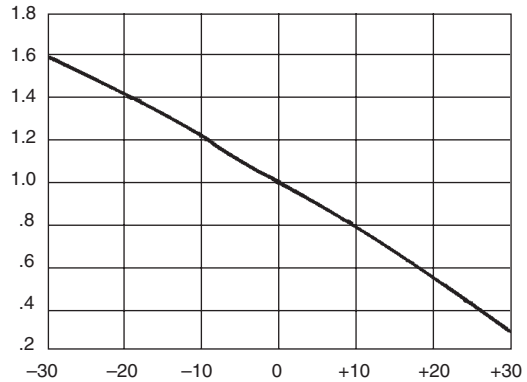

**ESTIMATING DOZER PRODUCTION OFF-THE-JOB**

Example problem:

Determine average hourly production of a D8T/8SU (with tilt cylinder) moving hard-packed clay an average distance of 45 m (150 feet) down a 15% grade, using a slot dozing technique.

Estimated material weight is 1600 kg/Lm<sup>3</sup> (2650 lb/LCY). Operator is average. Job efficiency is estimated at 50 min/hr.

Uncorrected Maximum Production — 458 Lm<sup>3</sup>/h (600 LCY/hr) (example only)

Applicable Correction Factors:

- Hard-packed clay is “hard to cut” material -0.80
- Grade correction (from graph) . . . . . -1.30
- Slot dozing . . . . . -1.20
- Average operator . . . . . -0.75
- Job efficiency (50 min/hr) . . . . . -0.83
- Weight correction . . . . . (2300/2650) -0.87

$$\begin{aligned}
 \text{Production} &= \text{Maximum Production} \times \text{Correction Factors} \\
 &= (600 \text{ LCY/hr}) (0.80) (1.30) (1.20) \\
 &\quad (0.75) (0.83) (0.87) \\
 &= 405.5 \text{ LCY/hr}
 \end{aligned}$$

To obtain production in metric units, the same procedure is used substituting maximum uncorrected production in Lm<sup>3</sup>.

$$\begin{aligned}
 &= 458 \text{ Lm}^3/\text{h} \times \text{Factors} \\
 &= 309.6 \text{ Lm}^3/\text{h}
 \end{aligned}$$

## MEASURING PRODUCTION ON-THE-JOB

Three generally accepted methods of measuring bulldozer production are listed below. The third method is empirical, but is the simplest to conduct.

1. Employing Surveying Techniques
  - a. Conduct time study and then cross-section the cut to determine the volume of material removed. (Production in  $Bm^3$  or BCY per unit of time)
  - b. Conduct time study and then cross-section the fill to determine the volume of fill material. (Production in  $Lm^3$  or LCY per unit of time)
2. Weighing Blade Loads  
Conduct time study and weigh material moved by bulldozer by weighing the loader bucket loads.
3. Measuring Blade Loads
  - a. Dozer operation
    - (1) Pick up and carry load onto a level area and stop.
    - (2) Raise the blade directly over the pile pulling forward slightly as blade comes up, leaving a nearly symmetrical pile.
    - (3) Reverse to clear the pile.
  - b. Measurements
    - (1) The average *height* (H) of the pile in feet. Hold the tape vertically at the inside edge of each grouser mark. Sight along top of the pile to obtain the correct measurement.

TOP VIEW

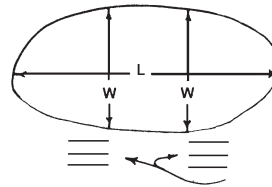

SIDE VIEW

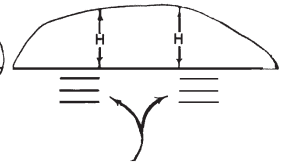

### GROUSER MARKS

- (2) The average *width* (W) of the pile in feet. Hold the tape horizontally over the pile and sight at the inside edge of each grouser mark and the corresponding opposite side of the pile.
- (3) The greatest *length* (L) of the pile in feet. Hold the tape horizontally over the pile and sight at each end of the pile.
- c. With the above measurements, now compute the blade load.
  - (1) Average the height measurement (H)
  - (2) Average the width measurement (W)
  - (3) Load ( $Lm^3$  or LCY) =  $0.0138 \times (HWL)$
  - (4) Load ( $Bm^3$  or BCY) =  $Lm^3$  or  $LCY \times LF$
- d. Combine the calculated blade load with time study to figure production.

## WORK TOOLS

### VARIABLE RADIUS (VR) SEMI-U BLADES

	D6R Series 3/D6T		D7R Series 2		D8R/D8T	
Capacity	5.81 m <sup>3</sup>	7.6 yd <sup>3</sup>	7.84 m <sup>3</sup>	10.25 yd <sup>3</sup>	11.28 m <sup>3</sup>	14.75 yd <sup>3</sup>
Width	3349 mm	11'0"	3912 mm	12'10"	4369 mm	14'4"
Height	1473 mm	4'10"	1626 mm	5'4"	1778 mm	5'10"
Weight	1360 kg	3000 lb	2000 kg	4400 lb	3010 kg	6640 lb

### LANDFILL BLADES

	D6R Series 3/D6T		D7R Series 2		D8R/D8T		D9R/D9T	
Capacity	12.5 m <sup>3</sup>	16.4 yd <sup>3</sup>	18.1 m <sup>3</sup>	23.7 yd <sup>3</sup>	24.4 m <sup>3</sup>	32 yd <sup>3</sup>	38.5 m <sup>3</sup>	50.3 yd <sup>3</sup>
Width	3886 mm	12'9"	4267 mm	14'0"	4928 mm	16'2"	5442 mm	17'10"
Height	1796 mm	5'10.7"	2083 mm	6'10"	2286 mm	7'6"	2178 mm	7'1.75"
Weight	1450 kg	3200 lb	2608 kg	5750 lb	3175 kg	7000 lb	4900 kg	10,800 lb

This list is not all inclusive. Contact your Caterpillar Dealer for special attachment needs.

## Bulldozers

### Special Attachments

- Coal U-Blades   ● Woodchip Dozers
- Reclamation U-Blades   ● Cushion Dozers

COAL U-BLADES	D6R Series 3/D6T		D7R Series 2		D8R/D8T		D9R/D9T	
Capacity	9.7 m <sup>3</sup>	<b>12.63 yd<sup>3</sup></b>	16.1 m <sup>3</sup>	<b>21.0 yd<sup>3</sup></b>	21.4 m <sup>3</sup>	<b>28 yd<sup>3</sup></b>	37 m <sup>3</sup>	<b>48 yd<sup>3</sup></b>
Width	4267 mm	<b>14'0"</b>	4953 mm	<b>16'3"</b>	5537 mm	<b>18'2"</b>	5940 mm	<b>18'10"</b>
Height	1473 mm	<b>4'10"</b>	1829 mm	<b>6'0"</b>	1930 mm	<b>6'4"</b>	2540 mm	<b>8'4"</b>
Weight	1452 kg	<b>3200 lb</b>	2405 kg	<b>5300 lb</b>	3200 kg	<b>7050 lb</b>	4490 kg	<b>9900 lb</b>

COAL U-BLADES	D10T		D11T	
Capacity	46.1 m <sup>3</sup>	<b>60.3 yd<sup>3</sup></b>	74.9 m <sup>3</sup>	<b>98.0 yd<sup>3</sup></b>
Width	6191 mm	<b>20'1"</b>	7416 mm	<b>24'4"</b>
Height	2794 mm	<b>9'2"</b>	3330 mm	<b>10'11"</b>
Weight	6670 kg	<b>14,700 lb</b>	11 340 kg	<b>25,000 lb</b>

WOODCHIP DOZERS	D6R Series 3/D6T		D7R Series 2		D8R/D8T		D9R/D9T		D10T	
Capacity	15 m <sup>3</sup>	<b>20 yd<sup>3</sup></b>	19.9 m <sup>3</sup>	<b>26 yd<sup>3</sup></b>	28.3 m <sup>3</sup>	<b>37 yd<sup>3</sup></b>	45.9 m <sup>3</sup>	<b>60 yd<sup>3</sup></b>	72.6 m <sup>3</sup>	<b>95 yd<sup>3</sup></b>
Width	4267 mm	<b>14'0"</b>	4826 mm	<b>16'8"</b>	5486 mm	<b>18'0"</b>	5486 mm	<b>18'0"</b>	6300 mm	<b>20'8"</b>
Height	1880 mm	<b>6'2"</b>	2083 mm	<b>6'10"</b>	2337 mm	<b>7'8"</b>	3086 mm	<b>10'1.5"</b>	3480 mm	<b>11'5"</b>
Weight	1724 kg	<b>3800 lb</b>	2765 kg	<b>6100 lb</b>	2903 kg	<b>6400 lb</b>	5080 kg	<b>11,200 lb</b>	7575 kg	<b>16,700 lb</b>

RECLAMATION U-BLADES	D8R/D8T		D9R/D9T		D10T	
Capacity	16.4 m <sup>3</sup>	<b>21.5 yd<sup>3</sup></b>	20.9 m <sup>3</sup>	<b>27.3 yd<sup>3</sup></b>	30.6 m <sup>3</sup>	<b>40 yd<sup>3</sup></b>
Width	4877 mm	<b>16'0"</b>	5182 mm	<b>17'0"</b>	5664 mm	<b>18'7"</b>
Height	1880 mm	<b>6'2"</b>	2032 mm	<b>6'8"</b>	2388 mm	<b>7'10"</b>
Weight	3810 kg	<b>8400 lb</b>	5220 kg	<b>11,500 lb</b>	6440 kg	<b>14,200 lb</b>

CUSHION DOZERS	D8R/D8T		D9R/D9T		D10T		D11T	
Width	2889 mm	<b>9'5.75"</b>	3048 mm	<b>10'0"</b>	3505 mm	<b>11'6"</b>		
Height	1499 mm	<b>4'11"</b>	1575 mm	<b>5'2"</b>	1676 mm	<b>5'6"</b>	*	
Weight	3185 kg	<b>7020 lb</b>	4310 kg	<b>9500 lb</b>	6440 kg	<b>14,200 lb</b>		

Rear Cushion Push Block	*	2175 kg	<b>4800 lb</b>	3105 kg	<b>6850 lb</b>	*
-------------------------	---	---------	----------------	---------	----------------	---

\*Available upon request.  
This list is not all inclusive. Contact your Caterpillar Dealer.

# RIPPERS

## CONTENTS

Features .....	1-59
Ripper Specification Diagrams	
Adjustable Parallelogram Ripper .....	1-60
Radial Ripper .....	1-62
Fixed Parallelogram Ripper .....	1-62
Specifications	
Track-Type Tractors .....	1-63
Tip Selection .....	1-72
Estimating Ripping Production .....	1-72
Seismic Wave Velocity Charts .....	1-75
Estimated Ripper Production Graphs .....	1-80

## Features:

- **Parallelogram linkage with hydraulically variable pitch** on D7E, D7R Series 2, D8R/D8T, D9R/D9T, D10T and D11T. Operator can adjust angle of ripper tip to the material for penetration at all ripping depths to increase production.
- **Fixed Parallelogram linkage design** used on D3K, D4K, D5K, D6K, D6N, D6G, D6G Series 2 XL, D6R, D6R XL, D6T, D6T XL, D7G and D7G Series 2. This design holds tooth angle constant at all ripping depths.
- **Adjustable Single shank** arrangements available for D8R/D8T, D9R/D9T, D10T and D11T for tough ripping applications and deep ripping requirements.
- **Hydraulically Variable Pitch Multi-shank** arrangements available on D8R/D8T, D9R/D9T, D10T and D11T allow wide-beam coverage in easier-to-rip materials.
- **Counterweighted CarryDozer Ripper single shank** available for D11T and D11T CD, multi-shank available for D11T CD.

**DEFINITION OF FORCES SHOWN IN TABLES THAT FOLLOW**

“Pryout,” (Breakout) kilonewtons (and pounds) — the maximum sustained upward force, generated by the lift cylinders measured at the ripper tip. Breakout force is measured with the shank in the top hole, shank vertical and ripper full down. Breakout force may be hydraulically or balance limited.

“Penetration force,” kilonewtons (and pounds) — the maximum sustained downward force, generated by the ripper lift cylinders measured at the ripper tip, which is required to raise the back end of the vehicle with the tip on ground and the shank (pinned in the top hole) vertical.

**Adjustable Parallelogram Ripper**

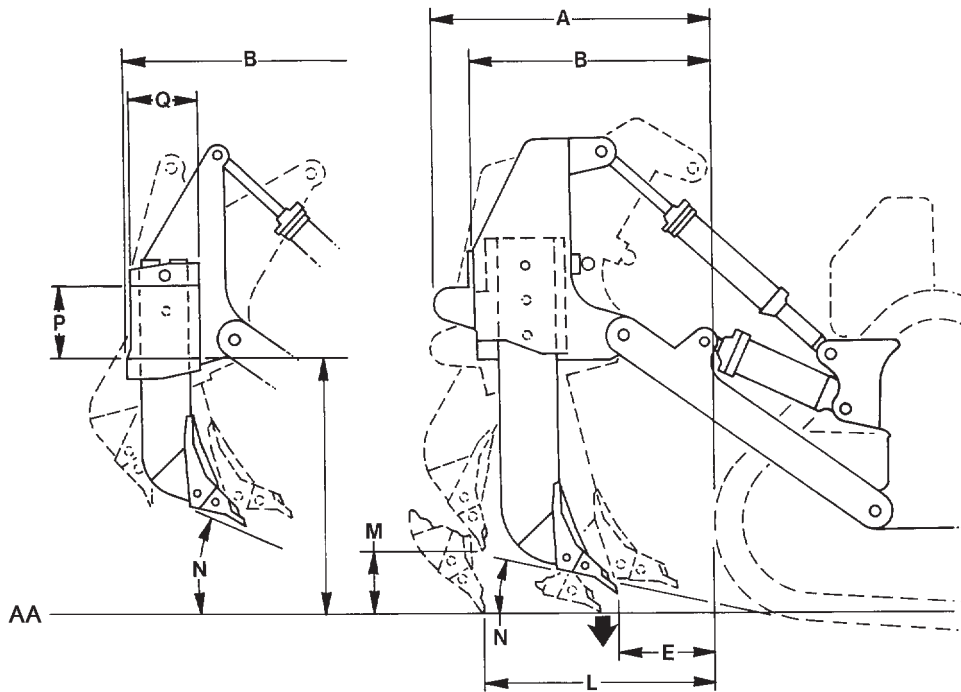

NOTE: Letters correspond to ripper specifications on pages that follow.

**KEY**

AA — Ground Line

Adjustable Parallelogram Ripper

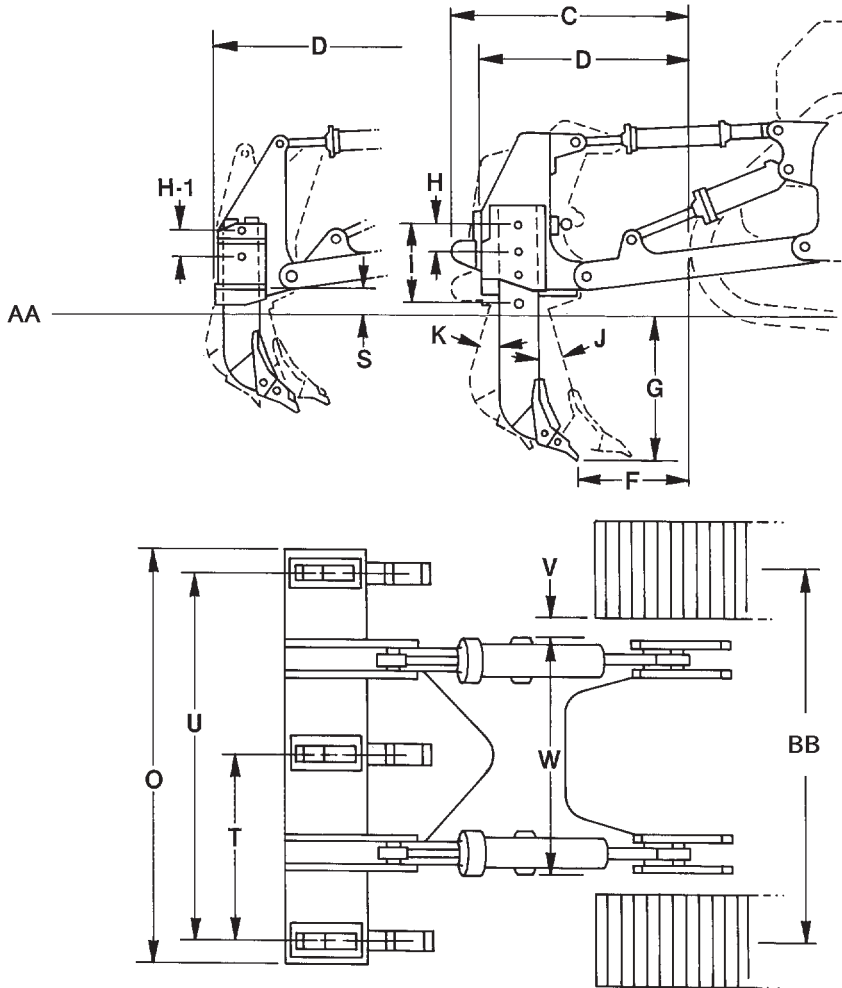

NOTE: Letters correspond to ripper specifications on pages that follow.

KEY

- AA — Ground Line
- BB — Track Gauge

# Rippers

## Specification Diagrams

- Radial Ripper
- Fixed Parallelogram Ripper

### Radial Ripper\*

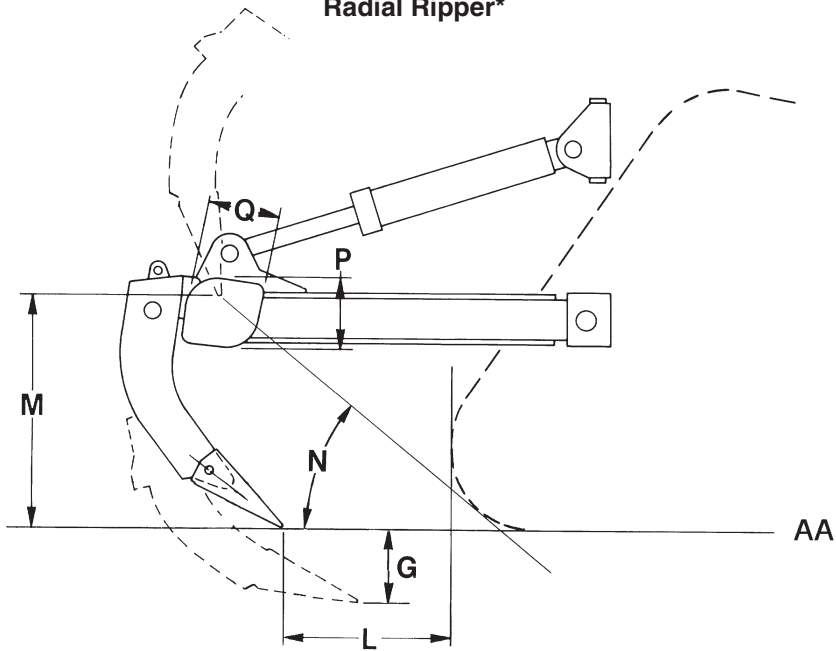

### Fixed Parallelogram Ripper

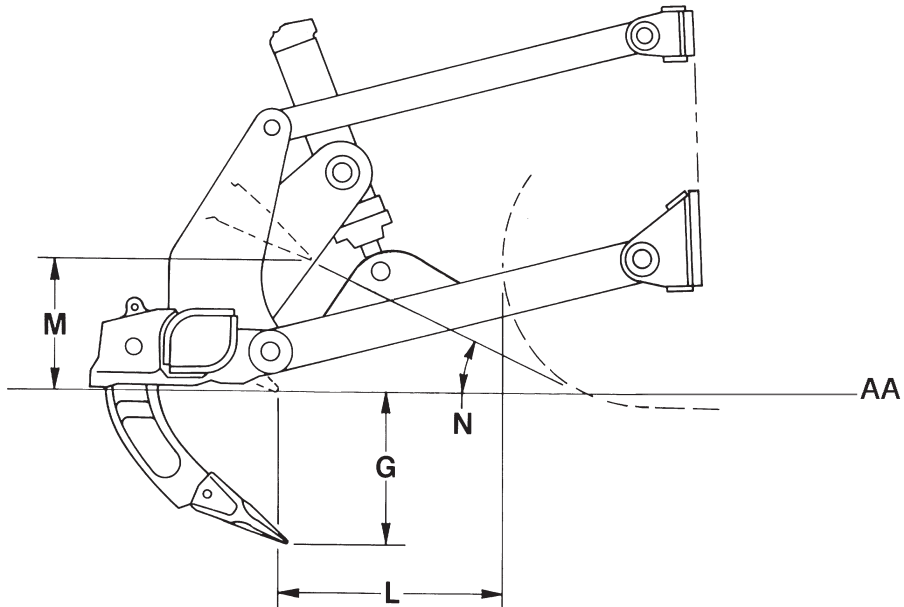

NOTE: Letters correspond to ripper specifications on pages that follow.

#### KEY

- AA — Ground Line
- \* — Tip Standard

TRACTOR/RIPPER	D3K		D4K		D5K	
Ripper Type	Fixed Parallelogram		Fixed Parallelogram		Fixed Parallelogram	
Dimensions:						
<b>Ripper Shank</b>						
<b>G</b> Maximum digging depth	338 mm	13.3"	338 mm	13.3"	338 mm	13.3"
<b>L</b> Maximum reach at ground line	766 mm	30.2"	596 mm	23.5"	555 mm	21.9"
<b>M</b> Maximum ground clearance under tip (shank pinned in bottom hole)	448 mm	17.6"	448 mm	17.6"	448 mm	17.6"
<b>N</b> Maximum ramp angle, ripper up (shank pinned in bottom hole)	27°		32°		33°	
Shank section	36 × 76 mm	1.4" × 3"	36 × 76 mm	1.4" × 3"	36 × 76 mm	1.4" × 3"
<b>Ripper Beam</b>						
<b>O</b> Overall width	1710 mm	67.3"	1710 mm	67.3"	1710 mm	67.3"
<b>P</b> Height	165 mm	6.5"	165 mm	6.5"	165 mm	6.5"
<b>Q</b> Length	190 mm	7.5"	190 mm	7.5"	190 mm	7.5"
Number of Pockets	3		3		3	
<b>T</b> Pocket Spacing	775 mm	30.5"	775 mm	30.5"	775 mm	30.5"
<b>U</b> Shank Gauge	1.55 m	61.0"	1.55 m	61.0"	1.55 m	61.0"
<b>V</b> Track clearance with standard shoe	80 mm	3.2"	80 mm	3.2"	80 mm	3.2"
Installed weights:						
Ripper with standard shank	554 kg	1222 lb	554 kg	1222 lb	554 kg	1222 lb
<b>Ripper Forces:*</b>						
Penetration Force	22.1 kN	4970 lb	24.7 kN	5560 lb	27.3 kN	6130 lb
Pryout Force	44.0 kN	9900 lb	44.0 kN	9900 lb	44.0 kN	9900 lb

\*This value may vary slightly with various vehicle configurations.

NOTE: Letters correspond to ripper dimension drawings.



TRACTOR/RIPPER	D6K XL		D6K LGP		D6N XL	
Ripper Type	Fixed Parallelogram		Fixed Parallelogram		Parallelogram	
Dimensions:						
<b>Ripper Shank</b>						
<b>G</b> Maximum digging depth	360 mm	<b>14.2"</b>	360 mm	<b>14.2"</b>	474 mm	<b>18.6"</b>
<b>L</b> Maximum reach at ground line	725 mm	<b>28.5"</b>	725 mm	<b>28.5"</b>	516 mm	<b>1'8.3"</b>
<b>M</b> Maximum ground clearance under tip (shank pinned in bottom hole)	471 mm	<b>18.5"</b>	471 mm	<b>18.5"</b>	392 mm	<b>15.4"</b>
<b>N</b> Maximum ramp angle, ripper up (shank pinned in bottom hole)	<b>26°</b>		<b>26°</b>		<b>23.5°</b>	
Shank section	58.5 × 138 mm <b>(2.3 × 5.4")</b>		58.5 × 138 mm <b>(2.3 × 5.4")</b>		73 × 176 mm <b>(2.9" × 6.9")</b>	
<b>Ripper Beam</b>						
<b>O</b> Overall width	1951 mm	<b>76.8"</b>	1951 mm	<b>76.8"</b>	2.20 m	<b>7'3"</b>
<b>P</b> Height	165 mm	<b>6.5"</b>	165 mm	<b>6.5"</b>	216 mm	<b>8.5"</b>
<b>Q</b> Length	211 mm	<b>8.3"</b>	211 mm	<b>8.3"</b>	254 mm	<b>10"</b>
Number of Pockets	<b>3</b>		<b>3</b>		<b>3</b>	
<b>T</b> Pocket Spacing	896 mm	<b>35.3"</b>	896 mm	<b>35.3"</b>	1000 mm	<b>3'3.4"</b>
<b>U</b> Shank Gauge	1792 mm	<b>70.6"</b>	1792 mm	<b>70.6"</b>	2 m	<b>6'7"</b>
<b>V</b> Track clearance with standard shoe	81 mm	<b>3.2"</b>	89 mm	<b>3.5"</b>	99 mm	<b>3.9"</b>
Installed weights:						
Ripper with standard shank	845 kg	<b>1863 lb</b>	845 kg	<b>1863 lb</b>	1406 kg	<b>3100 lb</b>
Each additional shank	34 kg	<b>75 lb</b>	34 kg	<b>75 lb</b>	78 kg	<b>172 lb</b>
<b>Ripper Forces:*</b>						
Penetration Force	42.2 kN	<b>9480 lb</b>	45.1 kN	<b>10,138 lb</b>	59.1 kN	<b>13,278 lb</b>
Pryout Force	166.7 kN	<b>37,480 lb</b>	166.7 kN	<b>37,480 lb</b>	123.6 kN	<b>27,778 lb</b>

\*This value may vary slightly with various vehicle configurations. D5N LGP equipped with VPAT-blade and Power Shift Transmission.

**NOTE:** Letters correspond to ripper dimension drawings.

TRACTOR/RIPPER	D6N LGP		D6R		D6R XL	
Ripper Type	Parallelogram		Parallelogram		Parallelogram	
Dimensions:						
<b>Ripper Shank</b>						
<b>G</b> Maximum digging depth	360 mm	14.2"	500 mm	1'7.7"	500 mm	1'7.7"
<b>L</b> Maximum reach at ground line	453 mm	17.8"	729 mm	2'4.7"	729 mm	2'4.7"
<b>M</b> Maximum ground clearance under tip (shank pinned in bottom hole)	506 mm	1'7.3"	520 mm	1'8.5"	520 mm	1'8.5"
<b>N</b> Maximum ramp angle, ripper up (shank pinned in bottom hole)	49.5°		26°		26°	
Shank section	73 × 176 mm	2.9" × 6.9"	74 × 175 mm	2.9" × 6.9"	74 × 175 mm	2.9" × 6.9"
<b>Ripper Beam</b>						
<b>O</b> Overall width	2.20 m	7'3"	2.20 m	7'3"	2.20 m	7'3"
<b>P</b> Height	216 mm	8.5"	216 mm	8.5"	216 mm	8.5"
<b>Q</b> Length	254 mm	10"	254 mm	10"	254 mm	10"
Number of Pockets	3		3		3	
<b>T</b> Pocket Spacing	1000 mm	3'3.4"	1000 mm	3'3.4"	1000 mm	3'3.4"
<b>U</b> Shank Gauge	2 m	6'7"	2 m	6'7"	2 m	6'7"
<b>V</b> Track clearance with standard shoe	104 mm	4.1"	120 mm	4.7"	120 mm	4.7"
Installed weights:						
Ripper with standard shank	1406 kg	3100 lb	1596 kg	3511 lb	1596 kg	3511 lb
Each additional shank	78 kg	172 lb	—		—	
<b>Ripper Forces:*</b>						
Penetration Force	70.6 kN	15,869 lb	64.2 kN	14,428 lb	64.2 kN	14,428 lb
Pryout Force	123.6 kN	27,778 lb	89.6 kN	20,140 lb	89.6 kN	20,140 lb

\*Tractor equipped with ripper, OROPS, SU dozer and heavy duty track. Values may vary slightly with various configurations. D6N LGP equipped with VPAT-blade and Power Shift Transmission.

**NOTE:** Letters correspond to ripper dimension drawings.

# Rippers

## Specifications

- D6R Series 3   ● D6R Series 3 XL   ● D6T
- D6T XL   ● D7R Series 2   ● D7E

TRACTOR/RIPPER	D6R Series 3		D6R Series 3 XL		D6T	
Ripper Type	Parallelogram		Parallelogram		Parallelogram	
Dimensions:						
<b>Ripper Shank</b>						
<b>G</b> Maximum digging depth	500 mm	1'7.7"	500 mm	1'7.7"	500 mm	1'7.7"
<b>L</b> Maximum reach at ground line	729 mm	2'4.7"	729 mm	2'4.7"	729 mm	2'4.7"
<b>M</b> Maximum ground clearance under tip (shank pinned in bottom hole)	520 mm	1'8.5"	520 mm	1'8.5"	520 mm	1'8.5"
<b>N</b> Maximum ramp angle, ripper up (shank pinned in bottom hole)	26°		26°		26°	
Shank section	74 × 175 mm	2.9" × 6.9"	74 × 175 mm	2.9" × 6.9"	74 × 175 mm	2.9" × 6.9"
<b>Ripper Beam</b>						
<b>O</b> Overall width	2.20 m	7'3"	2.20 m	7'3"	2.20 m	7'3"
<b>P</b> Height	216 mm	8.5"	216 mm	8.5"	216 mm	8.5"
<b>Q</b> Length	254 mm	10"	254 mm	10"	254 mm	10"
Number of Pockets	3		3		3	
<b>T</b> Pocket Spacing	1000 mm	3'3.4"	1000 mm	3'3.4"	1000 mm	3'3.4"
<b>U</b> Shank Gauge	2 m	6'7"	2 m	6'7"	2 m	6'7"
<b>V</b> Track clearance with standard shoe	120 mm	4.7"	120 mm	4.7"	120 mm	4.7"
Installed weights:						
Ripper with standard shank	1456 kg	3203 lb	1456 kg	3203 lb	1456 kg	3203 lb
Each additional shank	70 kg	154 lb	70 kg	154 lb	70 kg	154 lb
<b>Ripper Forces:*</b>						
Penetration Force	64.2 kN	14,428 lb	73.4 kN	16,505 lb	65.2 kN	14,665 lb
Pryout Force	89.6 kN	20,140 lb	89.6 kN	20,140 lb	89.6 kN	20,140 lb

TRACTOR/RIPPER	D6T XL		D7R Series 2		D7E	
Ripper Type	Parallelogram		Adj. Parallelogram		Adj. Parallelogram	
Dimensions:						
<b>Ripper Shank</b>						
<b>G</b> Maximum digging depth	500 mm	1'7.7"	748 mm	2'5.4"	650 mm	2'2"
<b>L</b> Maximum reach at ground line	729 mm	2'4.7"	1.07 m	3'6.1"	—	—
<b>M</b> Maximum ground clearance under tip (shank pinned in bottom hole)	520 mm	1'8.5"	638 mm	2'1.1"	588 mm	1'11"
<b>N</b> Maximum ramp angle, ripper up (shank pinned in bottom hole)	26°		26.6°		26°	
Shank section	74 × 175 mm	2.9" × 6.9"	72 × 228 mm	2.8" × 6.9"	72 × 228 mm	2.8" × 9.0"
<b>Ripper Beam</b>						
<b>O</b> Overall width	2.20 m	7'3"	2.21 m	7'3"	2088 mm	6'10"
<b>P</b> Height	216 mm	8.5"	279 mm	11"	—	—
<b>Q</b> Length	254 mm	10"	343 mm	13.5"	—	—
Number of Pockets	3		3		3	
<b>T</b> Pocket Spacing	1000 mm	3'3.4"	991 mm	3'3"	900 mm	2'11"
<b>U</b> Shank Gauge	2 m	6'7"	1.98 m	6'6"	1.80 m	5'11"
<b>V</b> Track clearance with standard shoe	120 mm	4.7"	95 mm	3.7"	—	—
Installed weights:						
Ripper with standard shank	1456 kg	3203 lb	3277 kg	7225 lb	1650 kg	3572 lb
Each additional shank	70 kg	154 lb	138 kg	305 lb	150 kg	330 lb
<b>Ripper Forces:*</b>						
Penetration Force	70.6 kN	15,863 lb	85.0 kN	19,104 lb	87.36 kN	19,639 lb
Pryout Force	89.6 kN	20,140 lb	176.6 kN	39,705 lb	234.4 kN	52,695 lb

\*Tractor equipped with ripper, OROPS, SU dozer and heavy duty track. Values may vary slightly with various configurations. D6N LGP equipped with VPAT-blade and Power Shift Transmission.

**NOTE:** Letters correspond to ripper dimension drawings.

TRACTOR/RIPPER	D7E		D8R/D8T			
	Adjustable Parallelogram		Adjustable Parallelogram			
	Multi-shank		Single Shank		Multi-shank	
Dimensions:						
<b>Ripper to Track</b>						
Ripper length behind track, shank vertical, ripper up						
<b>A</b> With Pushblock	N/A		N/A		N/A	
<b>B</b> Without Pushblock	1222 mm	4'0"	1.69 m	5'7"	1.6 m	5'2"
Ripper length behind track, shank vertical, ripper down						
<b>C</b> With Pushblock	N/A		N/A		N/A	
<b>D</b> Without Pushblock	1660 mm	5'5"	1.84 m	6'0"	1.71 m	5'7"
Tip to track distance, shank vertical						
<b>E</b> Ripper Up	614 mm	2'0"	694 mm	2'3.3"	640 mm	2'1.2"
<b>F</b> Ripper Down	970 mm	3'2"	950 mm	3'1.4"	899 mm	2'11.4"
<b>Ripper Shank*</b>						
<b>G</b> Maximum digging depth	650 mm	2'2"	1130 mm	3'8.5"	780 mm	2'6.7"
<b>H</b> Dig adjustment per hole	230 mm	9"	305 mm	12"	250 mm	10"
<b>I</b> Total dig adjustment	230 mm	9"	610 mm	2'0"	250 mm	10"
Pitch Adjustment, ripper down:						
<b>J</b> Forward	16°		15°		14.9°	
<b>K</b> Backward	12°		9.9°		10°	
<b>L</b> Maximum reach at ground line	1156 mm	3'10"	1.32 m	4'3"	1.17 m	3'10"
<b>M</b> Maximum ground clearance under tooth (shank pinned in bottom hole)	588 mm	1'11"	636 mm	2'1"	593 mm	1'11.3"
<b>N</b> Maximum ramp angle, ripper up (shank pinned in bottom hole)	26°		28.2°		28.4°	
Shank Section	72 × 228 mm	2.8" × 9.0"	75 × 333 mm	2.9" × 13.1"	75 × 333 mm	2.9" × 13.1"
<b>Ripper Beam</b>						
<b>O</b> Overall width	2088 mm	6'10"	N/A		2.46 m	8'1"
<b>P</b> Height**	355.6 mm (dia)	14" (dia)	N/A		334 mm	13.1"
<b>Q</b> Length**	—		N/A		457 mm	18"
Clearance under beam, shank vertical						
<b>R</b> Ripper Up	1080 mm	3'7"	N/A		1.55 m	5'1"
<b>S</b> Ripper Down	145 mm	5.7"	N/A		449 mm	17.7"
Number of Pockets	3		1		3	
<b>T</b> Pocket Spacing	900 mm	2'11"	N/A		1092 mm	3'7"
<b>U</b> Shank Gauge	1800 mm	5'11"	N/A		2.17 m	7'1"
<b>V</b> Track Clearance with standard shoe	47 mm	1.9"	76 mm	3"	76 mm	3"
<b>W</b> Width across widest part of lift cylinders	1275 mm	4'2"	1.37 m	4'5"	1.37 m	4'5"
Installed Weights:						
Ripper with standard shank	1650 kg	3572 lb	4085 kg	9005 lb	4213 kg	9287 lb
Each additional tooth group	150 kg	330 lb	N/A		332 kg	730 lb
<b>Ripper Forces:***</b>						
Penetration Force, shank vertical	87.4 kN	19,639 lb	127.4 kN	28,620 lb	124.2 kN	27,920 lb
Pryout Force, shank vertical	234.4 kN	52,695 lb	222.8 kN	50,070 lb	227.9 kN	51,230 lb

\*Deep Ripping Shank is available for D8R/D8T single shank rippers. Hydraulic pin puller is standard with deep ripping shank. Deep Ripping Arrangement maximum digging depth is 1.57 m (5'2") for D8R/D8T.

\*\*D7E ripper beam circular cross section.

\*\*\*Forces for D7E are for machine equipped with SU-blade and standard track. Forces for D8R/D8T are for a ripper on a tractor equipped with EROPS, U-Dozer and performance track. Forces will vary slightly with other vehicle configurations.

NOTE: Letters correspond to ripper dimension drawings.

## TRACTOR/RIPPER

## D9R/D9T

Ripper Type	Adjustable Parallelogram			
	Single Shank		Multi-shank	
Dimensions:				
<b>Ripper to Track</b>				
Ripper length behind track, shank vertical, ripper up				
A With Pushblock		N/A		N/A
B Without Pushblock	1.57 m	5'2"	1.33 m	4'4"
Ripper length behind track, shank vertical, ripper down				
C With Pushblock		N/A		N/A
D Without Pushblock	1.88 m	6'2"	1.71 m	5'7"
Tip to track distance, shank vertical				
E Ripper Up	689 mm	2'3.2"	510 mm	1'8.1"
F Ripper Down	944 mm	3'1.2"	890 mm	2'11"
<b>Ripper Shank*</b>				
G Maximum digging depth	1231 mm	4'0.6"	798 mm	2'7.6"
H Dig adjustment per hole	295 mm	12"	250 mm	10"
I Total dig adjustment	590 mm	1'11.2"	250 mm	10"
Pitch Adjustment, ripper down:				
J Forward		10.6°		10°
K Backward		15.2°		15.1°
L Maximum reach at ground line	1.25 m	4'1"	1.16 m	3'10"
M Maximum ground clearance under tooth (shank pinned in bottom hole)	882 mm	2'10.9"	885 mm	2'10.7"
N Maximum ramp angle, ripper up (shank pinned in bottom hole)		36.9°		37.5°
Shank Section	90 × 355 mm	3.5" × 14"	75 × 333 mm	2.9" × 13.1"
<b>Ripper Beam</b>				
O Overall width		N/A	2.64 m	8'8"
P Height		N/A	380 mm	15"
Q Length		N/A	457 mm	18"
Clearance under beam, shank vertical				
R Ripper Up		N/A	1.77 m	5'10"
S Ripper Down		N/A	378 mm	14.9"
Number of Pockets				
		1		3
T Pocket Spacing		N/A	1180 mm	3'10.4"
U Shank Gauge		N/A	2.35 m	7'8"
V Track Clearance with standard shoe	71 mm	2.8"	71 mm	2.8"
W Width across widest part of lift cylinders	1.50 m	4'11"	1.50 m	4'11"
Installed Weights:				
Ripper with standard shank	4854 kg	10,700 lb	4885 kg	10,770 lb
Each additional tooth group		N/A	332 kg	733 lb
<b>Ripper Forces:**</b>				
Penetration Force, shank vertical	153.9 kN	34,581 lb	148.0 kN	33,249 lb
Pryout Force, shank vertical	320.5 kN	72,025 lb	324.7 kN	74,639 lb

\*Deep Ripping Shank is available for D9R/D9T single shank rippers. Hydraulic pin puller is standard with deep ripping shank. Deep Ripping Arrangement maximum digging depth is 1.66 m (5'5") for D9R/D9T.

\*\*Forces are for a ripper on a tractor equipped with EROPS, U-Dozer and performance track. Forces will vary slightly with other vehicle configurations.

NOTE: Letters correspond to ripper dimension drawings.

TRACTOR/RIPPER	D10T		D11T		D11T			
	Adjustable Parallelogram		Adjustable Parallelogram		CD Multi-shank			
Ripper Type	Single Shank		Multi-shank		CD Single Shank		CD Multi-shank	
Dimensions:								
<b>Ripper to Track</b>								
Ripper length behind track, shank vertical, ripper up (A)								
A With Pushblock	2.08 m	6'10"	N/A		2.29 m	7'6"	N/A	
B Without Pushblock	1.76 m	5'9"	1.56 m	5'1"	1.97 m	6'6"	2.26 m	7'5"
Ripper length behind track, shank vertical, ripper down (A)								
C With Pushblock	2.48 m	8'2"	N/A		2.71 m	8'11"	N/A	
D Without Pushblock	2.16 m	7'1"	1.96 m	6'5"	2.39 m	7'10"	2.52 m	8'3"
Tip to track distance, shank vertical (A)								
E Ripper Up*	730 mm	2'4.7"	651 mm	2'1.6"	751 mm	2'6"	751 mm	2'6"
F Ripper Down**	1130 mm	3'8.5"	1050 mm	3'5.3"	1174 mm	3'10"	1174 mm	3'10"
<b>Ripper Shank***</b>								
G Maximum digging depth**	1494 mm	4'11"	876 mm	2'10.5"	1590 mm	5'3"	1510 mm	4'11"
H Dig adjustment per hole	355 mm	14"	250 mm	10"	280 mm	11"	280 mm	11"
I Total dig adjustment	710 mm	2'4"	250 mm	10"	840 mm	2'9.1"	840 mm	2'9.1"
Pitch Adjustment, ripper down:								
J Forward	15.4°		18.1°		15°		13°	
K Backward	29.7°		23.2°		31.9°		31.9°	
L Maximum reach at ground line**	1.60 m	5'3"	1.39 m	4'7"	1.87 m	6'2"	1.87 m	6'2"
M Maximum ground clearance under tooth (shank pinned in bottom hole)	930 mm	3'1"	1120 mm	3'8"	1150 mm	3'9"	1150 mm	3'9"
N Maximum ramp angle, ripper up (shank pinned in bottom hole)	35.7°		50.9°		34.1°		34.1°	
Shank Section	100 × 400 mm (4" × 15.75")		90 × 355 mm (3.5" × 14")		110 × 450 mm (4.3" × 17.7")		110 × 450 mm (4.3" × 17.7")	
<b>Ripper Beam</b>								
O Overall width	N/A		2.92 m	9'7"	N/A		N/A	
P Height	N/A		1350 mm	4'5"	N/A		N/A	
Q Length	N/A		990 mm	3'3"	N/A		N/A	
Clearance under beam, shank vertical								
R Ripper Up	N/A		2.03 m	6'8"	N/A		N/A	
S Ripper Down	N/A		380 mm	15"	N/A		N/A	
Number of Pockets	1		3		1		1	
T Pocket Spacing	N/A		1320 mm	4'4"	N/A		N/A	
U Shank Gauge	N/A		2.63 m	8'8"	N/A		N/A	
V Track Clearance with standard shoe	97 mm	4"	97 mm	4"	141 mm	5.6"	141 mm	5.6"
W Width across widest part of lift cylinders	1.75 m	5'9"	1.75 m	5'9"	1.90 m	6'3"	1.90 m	6'3"
Installed Weights:								
Ripper with standard shank	7150 kg	15,763 lb	6919 kg	15,253 lb	9356 kg	20,626 lb	12 733 kg	28,071 lb
Each additional tooth group	N/A		524 kg	1155 lb	N/A		N/A	
<b>Ripper Forces:****</b>								
Penetration Force, shank vertical	207.9 kN	46,715 lb	191.4 kN	43,023 lb	288.5 kN	84,850 lb	326.3 kN	73,361 lb
Pryout Force, shank vertical	481.7 kN	108,251 lb	484.9 kN	109,022 lb	622.7 kN	139,998 lb	641.8 kN	144,288 lb

\*With Standard Shank pinned in the bottom hole.

\*\*With Standard Shank pinned in the top hole.

\*\*\*Deep Ripping Shank is available for the D10T and D11T single shank rippers. Deep Ripping Arrangement maximum digging depth is 1.80 m (5'11") for the D10T and 2.17 m (7'1") for the D11T.

\*\*\*\*Forces are for a ripper on a tractor equipped with an EROPS, U-Dozer and performance track. Forces will vary slightly with other machine configurations.

All dimensions are approximate.

TRACTOR/RIPPER	D11T		D11T	
	CD Multi-shank		Multi-shank	
Dimensions:				
<b>Ripper to Track</b>				
Ripper length behind track, shank vertical, ripper up (A)				
A With Pushblock		N/A		N/A
B Without Pushblock	1.71 m	5'8"	1.69 m	5'6"
Ripper length behind track, shank vertical, ripper down (A)				
C With Pushblock		N/A		N/A
D Without Pushblock	2.16 m	7'1"	2.16 m	7'1"
Tip to track distance, shank vertical (A)				
E Ripper Up	0.78 m	2'7"	0.78 m	2'7"
F Ripper Down	1.96 m	6'5"	1.95 m	6'5"
<b>Shank*</b>				
G Maximum digging depth	1.01 m	3'4"	1.01 m	3'4"
H Dig adjustment per hole	280 mm	11"	280 mm	11"
I Total dig adjustment	280 mm	11"	280 mm	11"
Pitch Adjustment, ripper down:				
J Forward		12.2°		12.2°
K Backward		31.8°		31.8°
L Maximum reach at ground line	1.71 m	5'7"	1.71 m	5'7"
M Maximum ground clearance under tooth (shank pinned in bottom hole)	1.14 m	3'9"	1.16 m	3'10"
N Maximum ramp angle, ripper up (shank pinned in bottom hole)		36.4°		36.4°
Shank Section	100 × 400 mm	3.9" × 15.7"	100 × 400 mm	3.9" × 15.7"
<b>Ripper Beam</b>				
O Overall width	3.33 m	10'11"	3.33 m	10'11"
P Height	1.98 m	6'6"	1.98 m	6'6"
Q Length	1.01 m	3'4"	1.01 m	3'4"
Clearance under beam, shank vertical				
R Ripper Up	2.06 m	6'9"	2.06 m	6'9"
S Ripper Down	282 mm	11.1"	282 mm	11.1"
Number of Pockets				
T Pocket Spacing	1500 mm	5'9"	1500 mm	5'9"
U Shank Gauge	2.99 m	9'10"	2.99 m	9'10"
V Track Clearance with standard shoe	166 mm	5.6"	166 mm	5.6"
W Width across widest part of lift cylinders	1.9 m	6'3"	1.9 m	6'3"
Installed Weights:				
Ripper with standard shank	12 026 kg	26,513 lb	9251 kg	20,395 lb
Each additional tooth group	668 kg	1472 lb	668 kg	1472 lb
<b>Ripper Forces:**</b>				
Penetration Force, shank vertical	305.8 kN	68,739 lb	277.1 kN	62,297 lb
Pryout Force, shank vertical	650.0 kN	146,118 lb	646.4 kN	145,310 lb

\*Hydraulic pin puller is standard with deep ripping shank. Deep Ripping Arrangement maximum digging depth is 2.18 m (7'2").

\*\*Forces are for a ripper on a tractor equipped with an EROPS, U-Dozer and performance track. Forces will vary slightly with other vehicle configurations.

<b>TRACTOR/RIPPER</b>	<b>D6G/D6G Series 2 XL/ No. 6</b>		<b>D7G/D7G Series 2/ No. 7</b>	
<b>Ripper Type</b>	<b>Parallelogram</b>		<b>Parallelogram</b>	
Dimensions:				
<b>Ripper Shank</b>				
<b>G</b> Maximum digging depth	530 mm	<b>1'8.9"</b>	737 mm	<b>2'5"</b>
<b>L</b> Maximum reach at ground line	551 mm	<b>1'9.7"</b>	994 mm	<b>3'3.1"</b>
<b>M</b> Maximum ground clearance under tip (shank pinned in bottom hole)	218 mm	<b>8.6"</b>	462 mm	<b>18.2"</b>
<b>N</b> Maximum ramp angle, ripper up (shank pinned in bottom hole)	<b>16°</b>		<b>21°</b>	
Shank Section	76 × 178 mm <b>(3" × 7")</b>		72 × 228 mm <b>(2.8" × 9")</b>	
<b>Ripper Beam</b>				
<b>O</b> Overall width	2.34 m	<b>7'8"</b>	2.21 m	<b>7'3"</b>
<b>P</b> Height	214 mm	<b>8.4"</b>	279 mm	<b>11"</b>
<b>Q</b> Length	254 mm	<b>10"</b>	343 mm	<b>13.5"</b>
Number of Pockets	<b>5 — D6G</b>		<b>3</b>	
<b>T</b> Pocket Spacing	536 mm	<b>1'9.1"</b>	991 mm	<b>3'3"</b>
<b>U</b> Shank Gauge	2.15 m	<b>7'1"</b>	1.98 m	<b>6'6"</b>
<b>V</b> Track clearance with standard shoe	213 mm	<b>8.4"</b>	185 mm	<b>7.3"</b>
Installed weights:				
Ripper with standard shank	1500 kg	<b>3300 lb</b>	2429 kg	<b>5344 lb</b>
Each additional shank	64 kg	<b>141 lb</b>	155 kg	<b>341 lb</b>

**NOTE:** Letters correspond to ripper dimension drawings.



**TIP SELECTION FOR THE D8R/D8T, D9R/D9T, D10T AND D11T RIPPERS**

Three tip configurations (short, intermediate and long) in two styles (centerline and penetration) are available for economical operation in a variety of conditions.

**RECOMMENDED TIP USAGE**

*Short* — Use in high impact conditions where breakage problems occur. The shorter the tip, the more it resists breakage.

*Intermediate* — Most effective in moderate impact conditions where abrasion is not excessive.

*Long* — Use in loose, abrasive materials where breakage is not a problem. Generally offers the most wear material.

**Centerline vs Penetration**

The materials being ripped and the tractor doing the ripping will both have an effect on which tip will do the best job. High density material requires a “penetration” tip. High impact material requires a “centerline” tip. The following is a general guide to tip application.

Ripping Condition	Tips to use		
	D8R/D8T D9R/D9T	D10T	D11T
Tandem Tractors . . . . .	Short	Short	Short
Single Shank and Multi-shank			
Extreme Duty . . . . .	Int.	Short	Short
Medium Duty . . . . .	Long	Int.	Int.
Abrasive Duty . . . . .	Long	Long	Long

Always use the longest tip that will wear without excessive breakage. Different tips should be tried to determine the most economical.

**ESTIMATING RIPPING PRODUCTION**

Ripping costs must be compared to other methods of loosening the material — usually drilling and blasting — on a cost per ton or bank cubic yard basis. Thus, an accurate estimation of ripper production is needed to determine unit ripping costs.

There are three general methods of estimating ripping production:

1. The best method is to record the time spent ripping, then remove (using scrapers or loaders and trucks) and weigh the ripped material. The total weight divided by the time spent will give hourly production. If the contractor is paid by volume, then a density must be used and the accuracy is only as good as the density used. For payment by volume removed, method 2 may be desirable. Some care will be needed to assure that only ripped material is removed.
2. Another method is to cross-section the area and then record the time spent ripping. After the material has been removed, cross-section the area again to determine the volume of rock removed. The volume divided by the time spent ripping gives the ripping rate per minute or hour.
3. Timing the ripper over a measured distance is the least accurate method, but valuable for quick estimating on the job. An average cycle time should be determined from a number of timed cycles. Turn-around or back-up time must be included. Measure the average rip distance, rip spacing and depth of penetration. This data will give the volume per cycle from which the production in bank cubic yards can be calculated. Experience has shown results obtained from this method are about 10 to 20% higher than the more accurate method of cross-sectioning.

An example of the measured distance method for calculating ripper production is:

*Data* — D10T — No. 10 with one shank.  
910 mm (36 in) between passes.  
1.6 km/h (1 mph) average speed (including slippage and stalls).

Every 91 m (300 ft) requires 0.25 min to raise, pivot, turn, and lower again: 91 m (300 ft) = 1 pass.

610 mm (24 in) penetration.  
Full time ripping (no pushing or dozing assignment).

Example of Estimating Production (Metric)

Time per pass:

1.6 km/h = 26.7 m/min. Then  $\frac{91 \text{ m}}{26.7 \text{ m/min}} = 3.41 \text{ min};$

3.41 min + 0.25 min (turn time) = 3.66 min/pass.

If the operator works an average of 45 min per h, it is possible to make  $= \frac{45}{3.66} = 12.3$  passes per h

Volume ripped:  $91 \text{ m} \times 0.9 \text{ m} \times 0.6 \text{ m} = 49.1 \text{ BCM}$  per pass

Production =  $49.1 \times 12.3 = 604 \text{ BCM}$  per h

Remember the results from this method are usually 10 to 20 per cent higher than the actual production that can be expected on the job.

Example of Estimating Production (English)

Time per pass:

MPH = 88 fpm. Then  $\frac{300 \text{ ft}}{88 \text{ fpm}} = 3.41 \text{ min};$

3.41 min + 0.25 min. (turn time) = 3.66 min/pass.

If the operator works an average of 45 min per h, it is possible to make  $= \frac{45}{3.66} = 12.3$  passes per h

Volume ripped:  $\frac{300 \times 3 \times 2}{27} = 66.7 \text{ BCY}$  per pass

Production =  $66.7 \times 12.3 = 820 \text{ BCY}$  per hr



**NOTE:** The demands of heavy ripping will increase the normal owning and operating costs of the tractor.

These costs should be increased no less than 30-40% in heavy ripping applications to estimate rock loosening costs.

There is no ready answer or rule-of-thumb solution to predict ripping production. Even if everything is known about the seismic velocity of the material, its composition, job conditions, equipment and operator, only a "guesstimate" can be given. The final answer must come from a production study obtained on the job site.

Sample problem (Metric)

Determine the loosening costs in the following situation:

Machine	— D10T Tractor with No. 10 Single Shank Ripper
Rip Spacing	— 915 mm
Ripper Penetration	— 610 mm
Rip Distance	— 91 m
Rip Time	— 3.41 minutes
Maneuver Time	— 0.25 minutes
Seismic Velocity	— 1830 meters per second
Assume	60 min. hour

*Solution:*

- Total Cycle Time =  $3.41 + 0.25 = 3.66 \text{ min}$   
Cycles/hour =  $\frac{60 \text{ min/hr}}{3.66 \text{ min/cycle}} = 16.4$
- Production per cycle =  $91 \text{ m} \times 0.9 \text{ m} \times 0.6 \text{ m} = 49.1 \text{ BCM/cycle}$
- Production =  $49.1 \text{ BCM/cycle} \times 16.4 \text{ cycles/h} = 805 \text{ BCM/h}$
- Remember results of this method are usually 10 to 20% high.  
Actual Production = 80% of 805 BCM/h = 644 BCM/h  
Or 90% of 805 BCM/h = 725 BCM/h
- Owning and Operating Costs  
AD10T (ripping only) could have a \$115.00/h O & O costs including \$30/h operator.
- Loosening Costs  
 $\$115.00/\text{hr} \div 644 \text{ BCM/h} = \$0.179/\text{BCM}$   
 $\$115.00/\text{hr} \div 725 \text{ BCM/h} = \$0.159/\text{BCM}$   
The loosening cost should range from 15.9¢ to 17.9¢/BCM

Sample problem (English)

Determine the loosening costs in the following situation:

Machine	— D10T Tractor with No. 10 Single Shank Ripper
Rip Spacing	— 3 feet
Ripper Penetration	— 2 feet
Rip Distance	— 300 feet
Rip Time	— 3.41 minutes
Maneuver Time	— 0.25 minutes
Seismic Velocity	— 6000 feet per second
Assume	60 min. hour

*Solution:*

$$1. \text{ Total Cycle Time} = 3.41 + 0.25 = 3.66 \text{ min}$$

$$\text{Cycles/hour} = \frac{60 \text{ min/hr}}{3.66 \text{ min/cycle}} = 16.4$$

$$2. \text{ Production per cycle} = \frac{300 \times 3 \times 2}{27} = 66.7 \text{ BCY/cycle}$$

$$3. \text{ Production} = 66.7 \text{ BCY/cycle} \times 16.4 \text{ cycles/hr} = 1094 \text{ BCY/hour}$$

4. Remember results of this method are usually 10 to 20% high.

$$\text{Actual Production} = 80\% \times 1094 = 875 \text{ BCY/hr}$$

$$\text{or } 90\% \times 1094 = 984 \text{ BCY/hr}$$

5. Owning and Operating Costs

AD10T (ripping only) could have a \$115.00/hr  
O & O costs including \$30/hr operator

6. Loosening Costs

$$\$115.00/\text{hr} \div 875 \text{ BCY/hr} = \$0.131/\text{BCY}$$

$$\$115.00/\text{hr} \div 984 \text{ BCY/hr} = \$0.117/\text{BCY}$$

The loosening cost should range from 11.7¢ to 13.1¢/BCY



— Low seismic velocities of sedimentaries can indicate probable rippability. However, if the fractures and bedding joints do not allow tooth penetration, the material may not be ripped effectively.

— Pre-blasting or “popping” may induce sufficient fracturing to permit tooth entry, particularly in the caliches, conglomerates and some other rocks; but the economics should be checked carefully when considering popping in the higher grades of sandstones, limestones and granites.

Ripping is still more art than science, and much will depend on operator skill and experience. Ripping for scraper loading may call for different techniques than if the same material is to be dozed away. Cross-ripping requires a change in approach. The number of shanks used, length and depth of shank, tooth angle, direction, throttle position — all must be adjusted according to field conditions. Ripping success may well depend on the operator finding the proper combination for those conditions.

## USE OF SEISMIC VELOCITY CHARTS

The charts of ripper performance estimated by seismic wave velocities have been developed from field tests conducted in a variety of materials. Considering the extreme variations among materials and even among rocks of a specific classification, the charts must be recognized as being at best only one indicator of rippability.

Accordingly, consider the following precautions when evaluating the feasibility of ripping a given formation:

— Tooth penetration is often the key to ripping success, regardless of seismic velocity. This is particularly true in homogeneous materials such as mudstones and claystones and the fine-grained caliches. It is also true in tightly cemented formations such as conglomerates, some glacial tills and caliches containing rock fragments.

**D8R/D8T**

- Multi- or Single Shank No. 8 Ripper
- Estimated by Seismic Wave Velocities

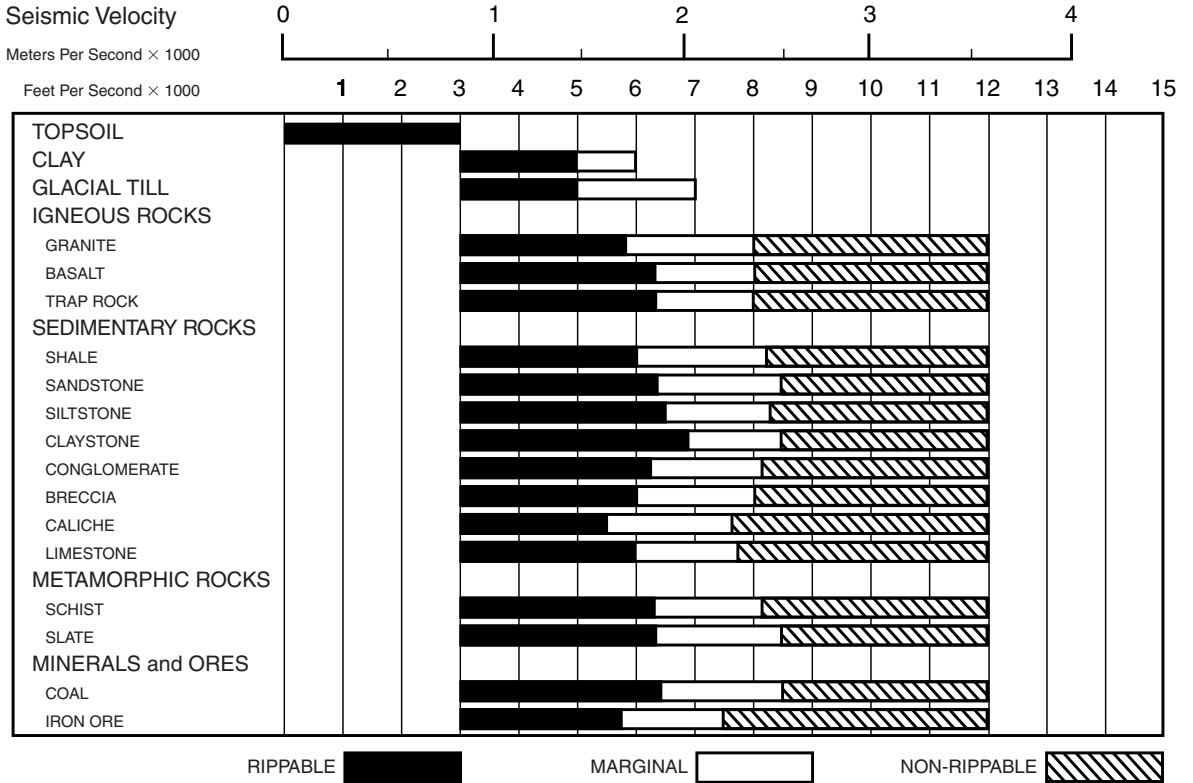

**D9R/D9T**

- Multi- or Single Shank No. 9 Ripper
- Estimated by Seismic Wave Velocities

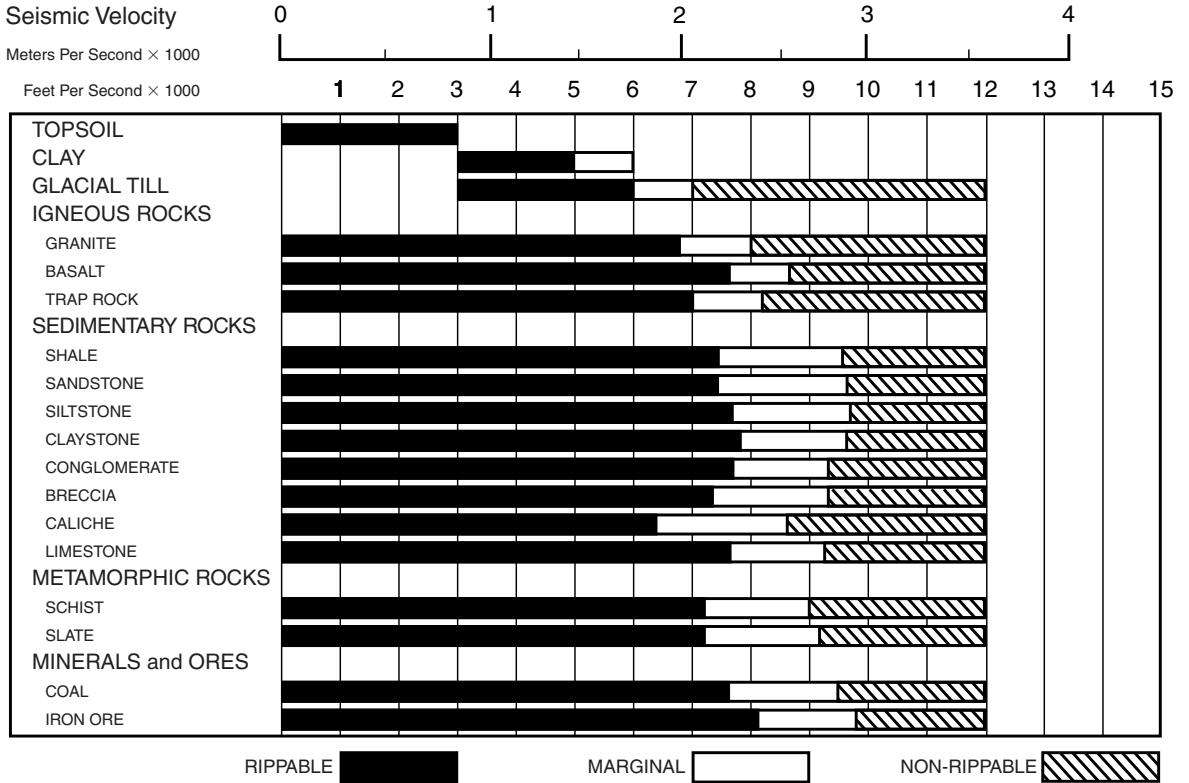

**D10T**

- Multi- or Single Shank No. 10 Ripper
- Estimated by Seismic Wave Velocities

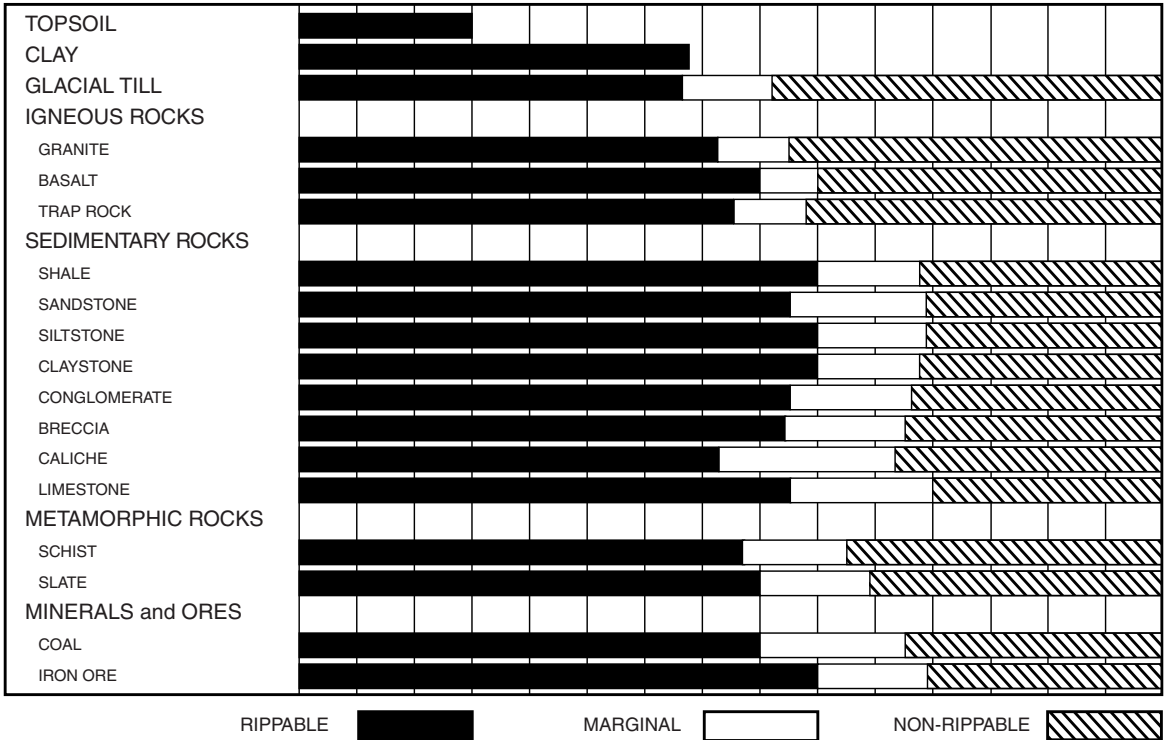
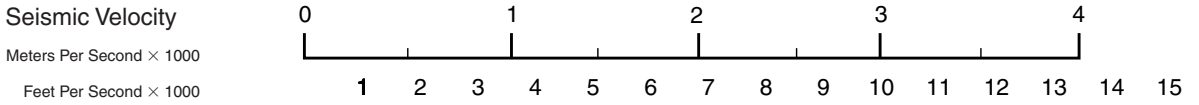

**D11T**

- Multi- or Single Shank No. 11 Ripper
- Estimated by Seismic Wave Velocities

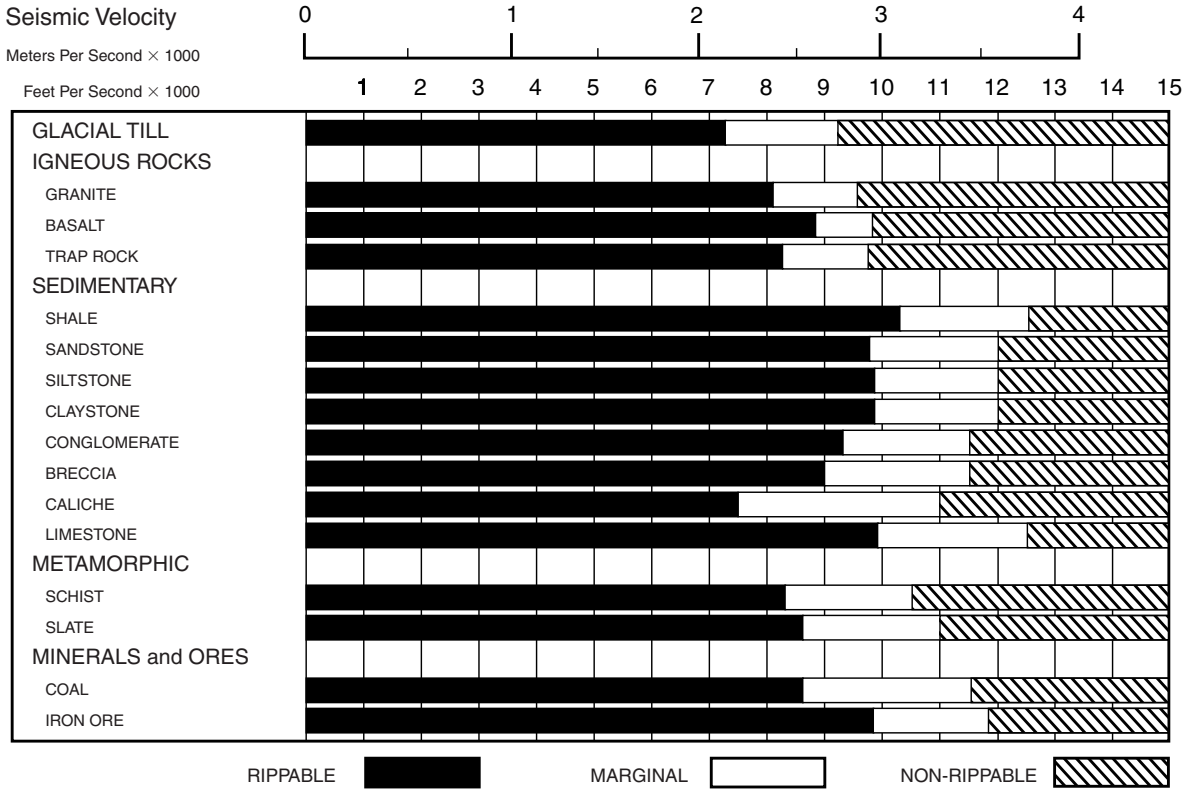

**D11T CD**

- Single Shank No. 11 Ripper
- Estimated by Seismic Wave Velocities

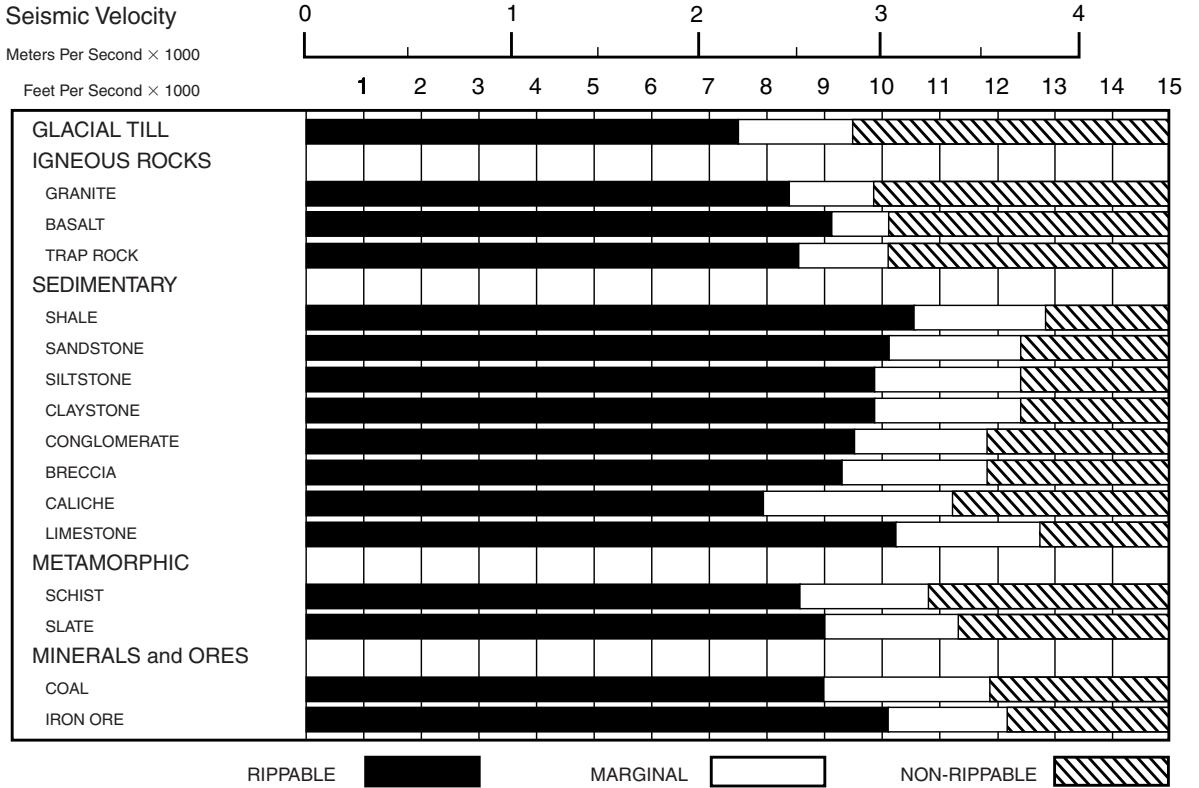



**CONSIDERATIONS FOR USING PRODUCTION ESTIMATED GRAPHS:**

- Machine rips full-time — no dozing.
- Power shift tractors with single shank rippers.
- 100% efficiency (60 min hour).
- Charts are for all classes of material.
- In igneous rock with seismic velocity of 8000 fps (2450 mps) or higher for the D11T, and 6000 fps (1830 mps) or higher for the D10T, D9R/D9T and D8R/D8T, the production figures shown should be reduced by 25%.
- Upper limit of charts reflect ripping under ideal conditions only. If conditions such as thick lamination, vertical lamination or any factor which would adversely affect production are present, the lower limit should be used.

**D8R/D8T WITH SINGLE SHANK**

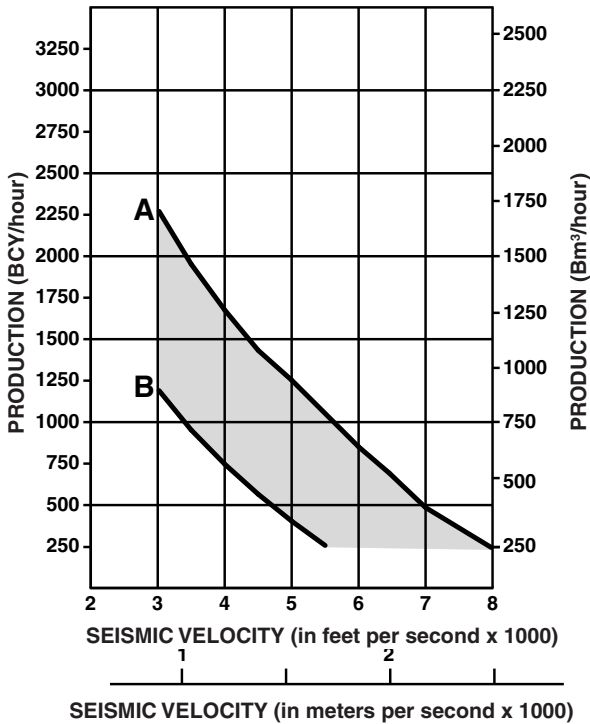

**D9R/D9T WITH SINGLE SHANK**

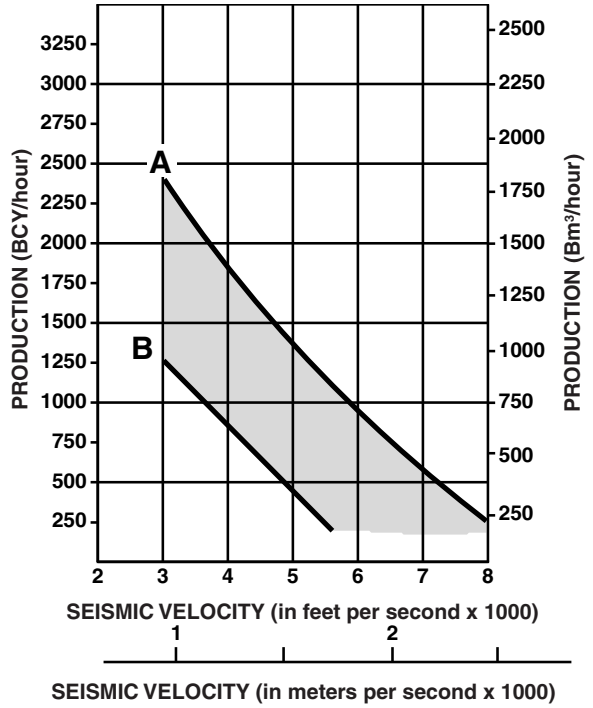

**KEY**  
 A — IDEAL  
 B — ADVERSE

D10T WITH SINGLE SHANK

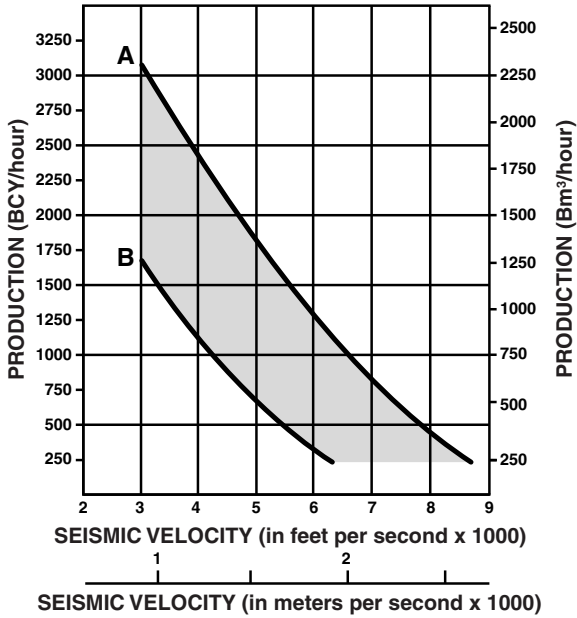

D11T WITH SINGLE SHANK

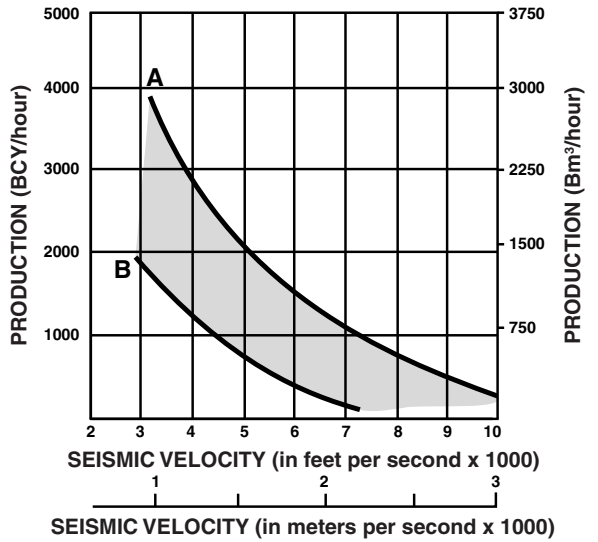

D11T CD WITH SINGLE SHANK

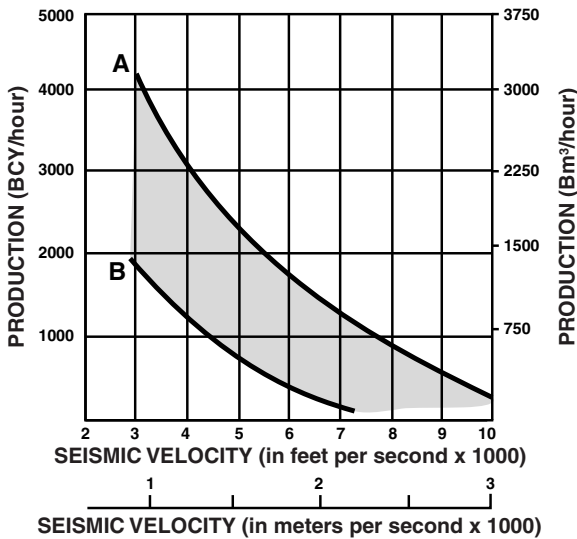

KEY

- A — IDEAL
- B — ADVERSE



# WINCHES PACCAR ALLIED

## CONTENTS

PACCAR Features .....1-83  
 Allied Features .....1-84  
 Physical Specifications .....1-85  
 Operating Specifications .....1-97

### PACCAR Features:

#### PA40 and PA50

- **Closed loop hydrostatic operation** with variable displacement motor and dedicated variable displacement pump for maximum winching power and flexibility.
- **Infinitely variable control** of line speed and line pull including positive inching control at maximum rated line pull.
- **Standard full-function “reel-in” and “reel-out” control.** This is optional on some competitive winches.
- **Standard “drive-away”** to maintain tension on the cable when driving the tractor away from a stationary load.
- **Standard “free spool”** to allow cable to be pulled off the winch by hand.
- **Durable cast winch case** with fairlead mounting lugs, log arch mounting lugs, and heavy duty drawbar.

#### PA55, PA56 and PA80

- **PTO mechanical winch drive** with full tractor engine power available to the winch.
- **Self-contained internal hydraulic control system** for easy installation.

- **Equal speed gearing in “reel-in” and “reel-out”** to provide smooth and predictable performance.
- **Standard “drive-away”** to maintain tension on the cable when driving the tractor away from a stationary load.
- **Standard “free spool”** to allow cable to be pulled off the winch by hand.
- **Durable cast winch case** with fairlead mounting lugs, log arch mounting lugs, and heavy duty drawbar.

#### PA90, PA110B, PA140 and H200

- **Hydraulically driven winch** for infinitely variable control of line speed and line pull including positive inching control at maximum rated line pull.
- **Optimized “high power” hydraulic control system** including specialized directional control valve for maximum winching power and flexibility.
- **Dual braking system** provides a static brake with sprag clutch to eliminate fall-back and a hydraulic brake valve for dynamic braking.
- **Single lever joystick control** for ease of operation.
- **Fabricated steel winch case** with integral heavy duty drawbar provides excellent durability and easy weldability.
- **Standard three-roller fairlead** for improved wire rope life during side pulls.

- PACCAR
- Allied

**PACCAR Features:****H60, H110B and H140**

- **Hydraulically driven winch** for infinitely variable control of line speed and line pull including positive inching control at maximum rated line pull.
- **Standard Cat ripper control system** is employed for winch “reel-in” and “reel-out” functions.
- **Winch installation time is reduced by up to 70%** compared to “high power” installations.
- **Easy field interchangeability between winch and ripper.**
- **Dual braking system** provides a static brake with sprag clutch to eliminate fall-back and a hydraulic brake valve for dynamic braking.
- **Durable cast (H60) or fabricated steel (H110B and H140) winch case** with integral heavy duty drawbar.
- **Three-roller fairlead** for improved wire rope life during side pulls is standard on H110B and H140 and optional on H60.
- **“Free spool”** to allow cable to be pulled off the winch by hand is standard on H60.

**Allied Features:**

- **Over 80 years of reliability on Caterpillar.** Allied winches trace their roots to Hyster winches on Caterpillar tractors since 1929. Hyster winches joined Allied in 1990, maintaining the same design and part numbers. Existing dealer parts inventory continues to be interchangeable to support the thousands of Allied/Hyster winches in the field.
- **“Plug and Play” design.** Winches come complete with all the necessary parts for field mounting on any tractor. They do not require “Winch Ready” packages pre-ordered on the tractors. This simplifies dealer inventory planning.
- **Self-Contained Hydraulics (SCH) design.** All hoses, pump and valve are inside the PTO winch frame, totally eliminating external leakage.

- **Two families of winches for your choice — Power Take-Off (PTO) driven or Hydraulically Driven winches:**

- PTO-driven, hydraulically controlled winches excel at delivering full engine power for unrivaled strong line pull. Models cover D3 through D10 class tractors, the widest PTO winch range in the industry.
- Hydraulically driven, hydraulically controlled winches for tractors without PTO such as D3-4-5K and D7E, or for applications that require slow and precision line speed control.

- **Winch Selection Guide:**

Tractor Class	PTO Winch	Hydraulic Winch
D3-5K	W3C	H4A
D5-6N	W5C	H5C
D6T, D6G	W6G	H6H
D7R, D7E	W8L	H8L
D8-9-10T	W12E	H12A

- **Product Features:**

- Multiple-disk oil clutches and brake on PTO winches are constantly oil-cooled for long life.
- Freespool with adjustable freespool drag to allow cable to be pulled out easily by hand.
- Drawbar provides an additional hitch for load towing.
- Brake-off (half-brake) keeps cable tight while the tractor drives away from the load on tow to prevent cable bird-nesting.
- Power reel-in and power reel-out.
- Fabricated box-section steel frame withstands demanding side pulls without the need for fairlead. Use fairlead only for frequent side pulls. Easy to weld on attachments, and easy to repair.

- **Optional Equipment:**

- Fairlead to handle frequent side pulls from all angles. Strong vertical and horizontal rollers reduce cable wear to extend cable life.
- Arch works like a raised fairlead to lift loads off ground for efficient skidding.
- Choice of standard gear ratio for fast operation in logging, or slow speed gear ratio for fine speed control in pipelaying and construction applications.
- Electronic Control for precise speed control. Simple plug-in connection makes installation “Plug and Play” easy.

PA40/PA50

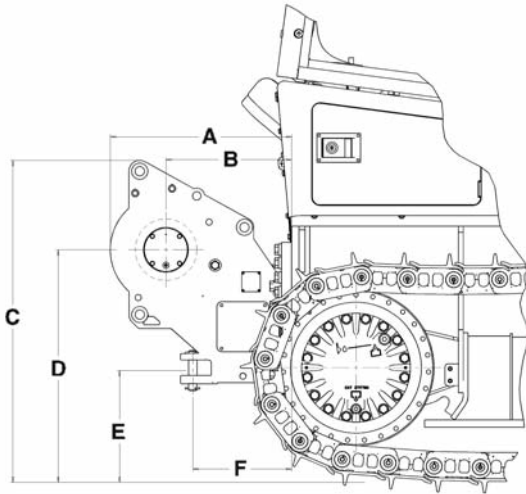

PA55

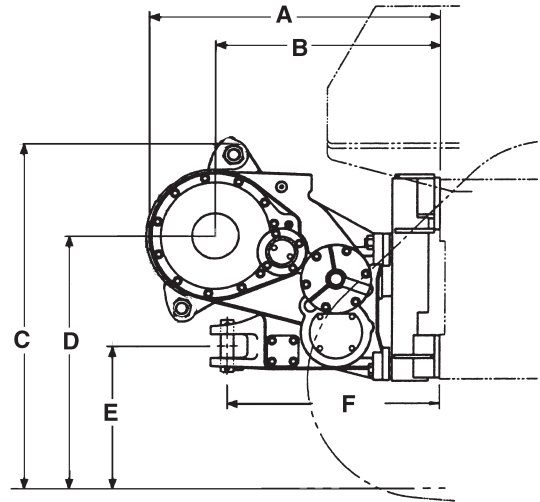

WINCH MODEL	PA40		PA50		PA55			
TRACTOR MODEL	D3K, D4K, D5K		D6K		D6N XL		D6N LGP	
Tractor transmission	Hydrostatic		Hydrostatic		Powershift		Powershift	
Winch drive	Hydrostatic		Hydrostatic		PTO		PTO	
A Tractor to rear of winch	751 mm	29.6"	845 mm	33.2"	1145 mm	45.1"	1145 mm	45.1"
B Tractor to drum centerline	521 mm	20.5"	615 mm	24.2"	890 mm	35.1"	890 mm	35.1"
C Ground to top of winch	1327 mm	52.2"	1380 mm	54.4"	1330 mm	52.3"	1380 mm	54.3"
D Ground to drum centerline	959 mm	37.8"	1010 mm	39.8"	960 mm	37.8"	1010 mm	39.8"
E Ground to center of hitch	473 mm	18.6"	525 mm	20.7"	525 mm	20.7"	575 mm	22.7"
F Tractor to drawbar pin centerline	410 mm	16.1"	505 mm	19.8"	845 mm	33.2"	845 mm	33.2"
Winch width (not shown) <sup>1</sup>	740 mm	29.2"	740 mm	29.2"	975 mm	38.3"	975 mm	38.3"
Drum diameter (not shown)	255 mm	10.0"	205 mm	8.0"	255 mm	10.0"	255 mm	10.0"
Weight <sup>2</sup>	610 kg	1345 lb	610 kg	1345 lb	1180 kg	2600 lb	1180 kg	2600 lb
Oil refill capacity	4.3 L	4.5 qt	4.3 L	4.5 qt	74 L	19.5 U.S. gal	74 L	19.5 U.S. gal
Wire rope diameter:								
Recommended	16 mm	0.63"	19 mm	0.75"	19 mm	0.75"	19 mm	0.75"
Optional	19 mm	0.75"	22 mm	0.88"	22 mm	0.88"	22 mm	0.88"
Maximum theoretical drum capacity: <sup>3</sup>								
Recommended rope	114 m	374'	93 m	306'	119 m	391'	119 m	391'
Optional rope	80 m	264'	67 m	220'	85 m	281'	85 m	281'
Maximum recommended drum capacity: <sup>4</sup>								
Recommended rope	83 m	272'	62 m	203'	81 m	267'	81 m	267'
Optional rope	55 m	180'	56 m	183'	55 m	180'	55 m	180'
Wire rope ferrule size (OD)	54 mm	2.13"	54 mm	2.13"	54 mm	2.13"	54 mm	2.13"
Wire rope ferrule size (length)	67 mm	2.63"	67 mm	2.63"	67 mm	2.63"	67 mm	2.63"

<sup>1</sup> Width does not include mounting brackets/adapters (if any).

<sup>2</sup> Weight shown is base winch only. Does not include mounting arrangement, control arrangement, oil, or wire rope.

<sup>3</sup> Per SAE J1158.

<sup>4</sup> Per SAE J706 (K=9).

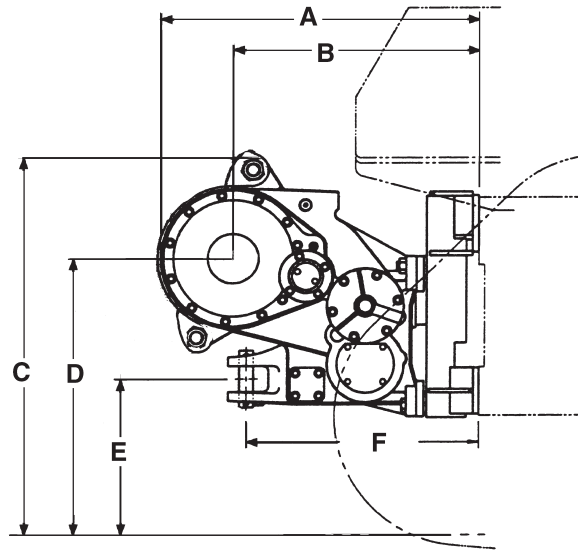

WINCH MODEL	H60				PA56	
TRACTOR MODEL	D6N XL		D6N LGP		D6T	
Tractor transmission	Powershift		Powershift		Powershift	
Winch drive	Hydraulic (ripper)		Hydraulic (ripper)		PTO	
A Tractor to rear of winch	1220 mm	48.1"	1220 mm	48.1"	1210 mm	47.7"
B Tractor to drum centerline	970 mm	38.1"	970 mm	38.1"	945 mm	37.7"
C Ground to top of winch	1330 mm	52.3"	1380 mm	54.3"	1480 mm	58.3"
D Ground to drum centerline	960 mm	37.8"	1010 mm	39.8"	1110 mm	43.7"
E Ground to center of hitch	525 mm	20.7"	575 mm	22.7"	675 mm	26.6"
F Tractor to drawbar pin centerline	920 mm	36.2"	920 mm	36.2"	910 mm	35.8"
Winch width (not shown) <sup>1</sup>	975 mm	38.3"	975 mm	38.3"	975 mm	38.3"
Drum diameter (not shown)	255 mm	10.0"	255 mm	10.0"	255 mm	10.0"
Weight <sup>2</sup>	1130 kg	2500 lb	1130 kg	2500 lb	1180 kg	2600 lb
Oil refill capacity	19 L	20 qt	19 L	20 qt	67 L	17.75 U.S. gal
Wire rope diameter:						
Recommended	22 mm	0.88"	22 mm	0.88"	22 mm	0.88"
Optional	26 mm	1"	26 mm	1"	26 mm	1"
Maximum theoretical drum capacity: <sup>3</sup>						
Recommended rope	85 m	281'	85 m	281'	85 m	281'
Optional rope	66 m	218'	66 m	218'	66 m	218'
Maximum recommended drum capacity: <sup>4</sup>						
Recommended rope	55 m	180'	55 m	180'	55 m	180'
Optional rope	50 m	163'	50 m	163'	50 m	163'
Wire rope ferrule size (OD)	54 mm	2.13"	54 mm	2.13"	54 mm	2.13"
Wire rope ferrule size (length)	67 mm	2.63"	67 mm	2.63"	67 mm	2.63"

<sup>1</sup> Width does not include mounting brackets/adapters (if any).

<sup>2</sup> Weight shown is base winch only. Does not include mounting arrangement, control arrangement, oil, or wire rope.

<sup>3</sup> Per SAE J1158.

<sup>4</sup> Per SAE J706 (K=9).

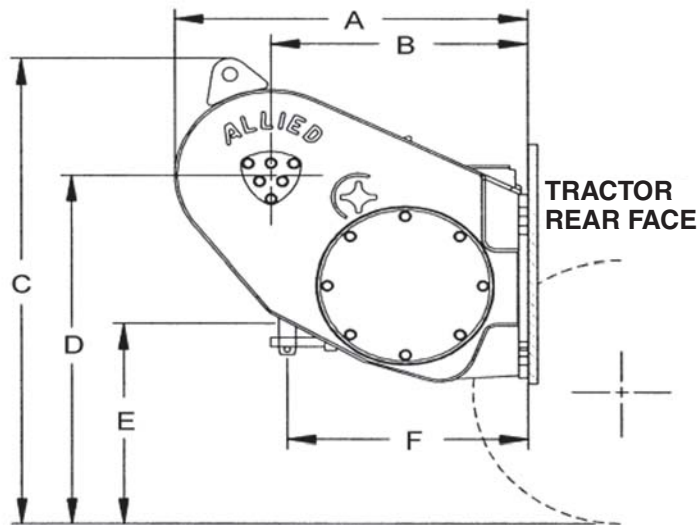

WINCH MODEL	H4AT		H4AH	
TRACTOR MODEL	D3K, D4K, D5K		D3K, D4K, D5K	
Winch drive	Ripper Hydraulics		Allied hi-flow pump	
Winch type	Rescue		Hi-Performance	
A Tractor to rear of winch	813 mm	2'8"	813 mm	2'8"
B Tractor to drum centerline	610 mm	2'0"	610 mm	2'0"
C Ground to top of winch	1143 mm	3'10"	1143 mm	3'10"
D Ground to drum centerline	864 mm	2'11"	864 mm	2'11"
E Ground to center of hitch	610 mm	2'1"	610 mm	2'1"
F Tractor to pin centerline	584 mm	1'11"	584 mm	1'11"
Overall width (not shown)	737 mm	2'5"	737 mm	2'5"
Drum diameter (not shown)	203 mm	8"	203 mm	8"
Weight	657 kg	1460 lb	698 kg	1540 lb
Oil refill capacity	19 L	5 U.S. gal	19 L	5 U.S. gal
Wire rope diameter:				
Recommended	16 mm	5/8"	16 mm	5/8"
Optional	19 mm	3/4"	19 mm	3/4"
Drum capacity:				
Recommended rope	84 m	277'	84 m	277'
Optional rope	59 m	195'	59 m	195'
Wire rope ferrule size (OD)	38 mm	1 1/2"	38 mm	1 1/2"
Wire rope ferrule size (length)	51 mm	2"	51 mm	2"



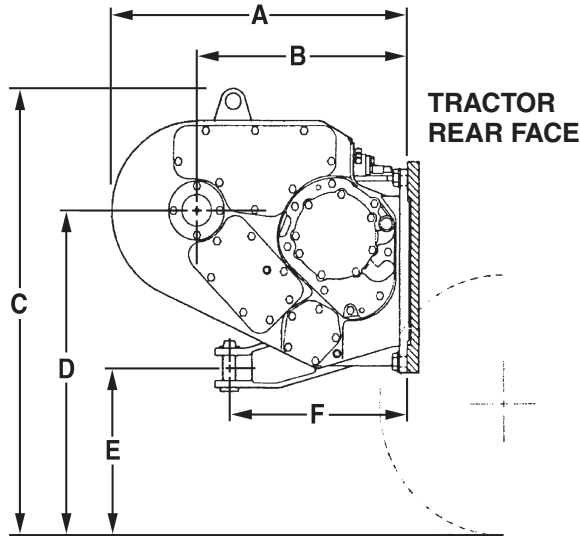

WINCH MODEL	H5CT		H5CH Hi-P	
TRACTOR MODEL	D6K		D6K	
Winch drive	Ripper Hydraulics		Allied hi-flow pump	
Winch type	Rescue		Hi-Performance	
A Tractor to rear of winch	863 mm	2'9"	863 mm	2'10"
B Tractor to drum centerline	635 mm	2'1"	635 mm	2'1"
C Ground to top of winch	1117 mm	3'8"	1117 mm	3'8"
D Ground to drum centerline	784 mm	2'7"	784 mm	2'7"
E Ground to center of hitch	381 mm	1'3"	381 mm	1'3"
F Tractor to pin centerline	559 mm	1'10"	559 mm	1'10"
Overall width (not shown)	813 mm	2'8"	813 mm	2'8"
Drum diameter (not shown)	217 mm	8.56"	217 mm	8.56"
Weight	898 kg	1980 lb	902 kg	2050 lb
Oil refill capacity	8 L	2 U.S. gal	8 L	2 U.S. gal
Wire rope diameter:				
Recommended	19 mm	¾"	19 mm	¾"
Optional	22 mm	⅞"	22 mm	⅞"
Drum capacity:				
Recommended rope	91 m	298'	91 m	298'
Optional rope	66 m	215'	66 m	215'
Wire rope ferrule size (OD)	51 mm	2"	51 mm	2"
Wire rope ferrule size (length)	57 mm	2¼"	57 mm	2¼"

PA56/PA80

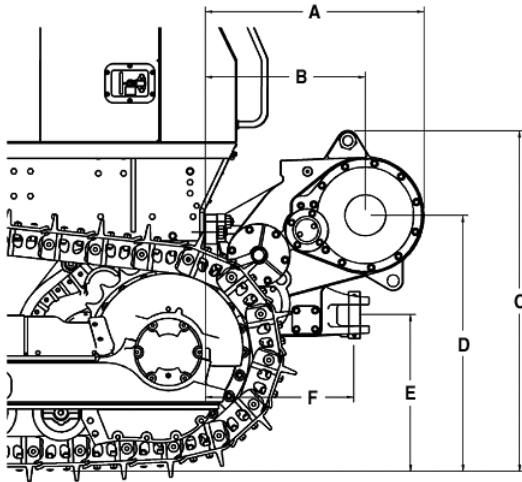

PA90

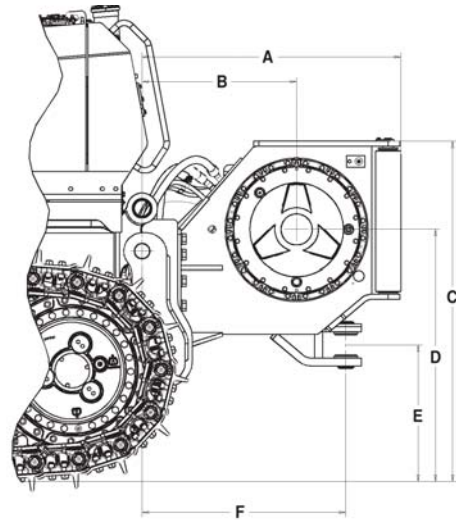

WINCH MODEL	PA56		PA80		PA90	
TRACTOR MODEL	D6G Series 2 XL		D7G Series 2		D7E	
Tractor transmission	Powershift		Powershift		Electric Hydraulic	
Winch drive	PTO		PTO			
A Tractor to rear of winch	1000 mm	39.4"	950 mm	37.4"	1265 mm	49.8"
B Tractor to drum centerline	745 mm	29.4"	695 mm	27.4"	755 mm	29.7"
C Ground to top of winch	1435 mm	56.5"	1515 mm	59.6"	1665 mm	65.6"
D Ground to drum centerline	1065 mm	41.9"	1145 mm	45.1"	1235 mm	48.5"
E Ground to center of hitch	630 mm	24.8"	710 mm	28.0"	670 mm	26.3"
F Tractor to drawbar pin centerline	700 mm	27.6"	650 mm	25.6"	995 mm	39.2"
Winch width (not shown) <sup>1</sup>	975 mm	38.3"	975 mm	38.3"	1090 mm	43.0"
Drum diameter (not shown)	255 mm	10"	290 mm	11.5"	320 mm	12.5"
Weight <sup>2</sup>	1180 kg	2600 lb	1180 kg	2600 lb	1520 kg	3350 lb
Oil refill capacity	74 L	19.5 U.S. gal	74 L	19.5 U.S. gal	12 L	12.5 qt
Wire rope diameter:						
Recommended	22 mm	0.88"	22 mm	0.88"	26 mm	1"
Optional	26 mm	1"	26 mm	1"	28 mm	1.13"
Maximum theoretical drum capacity: <sup>3</sup>						
Recommended rope	85 m	281'	76 m	250'	68 m	223'
Optional rope	66 m	218'	59 m	194'	54 m	178'
Maximum recommended drum capacity: <sup>4</sup>						
Recommended rope	55 m	180'	61 m	200'	56 m	183'
Optional rope	50 m	163'	39 m	127'	38 m	126'
Wire rope ferrule size (OD)	54 mm	2.13"	54 mm	2.13"	60 mm	2.38"
Wire rope ferrule size (length)	67 mm	2.63"	67 mm	2.63"	70 mm	2.75"

<sup>1</sup> Width does not include mounting brackets/adapters (if any).

<sup>2</sup> Weight shown is base winch only. Does not include mounting arrangement, control arrangement, oil, or wire rope.

<sup>3</sup> Per SAE J1158.

<sup>4</sup> Per SAE J706 (K=9).

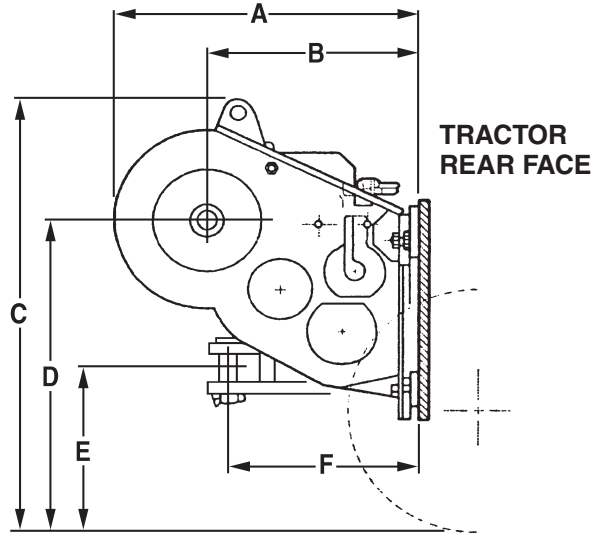

WINCH MODEL	H6GT		W6G		W6F	
TRACTOR MODEL	D6N		D6N		D6G Series 2	
Winch drive	Ripper Hydraulics		PTO		PTO	
Winch type	Rescue		Standard		Standard	
A Tractor to rear of winch	1194 mm	3'11"	1194 mm	3'11"	935 mm	3'1"
B Tractor to drum centerline	940 mm	3'1"	940 mm	3'1"	681 mm	2'3"
C Ground to top of winch	1422 mm	4'8"	1422 mm	4'8"	1397 mm	4'7"
D Ground to drum centerline	1066 mm	3'6"	1066 mm	3'6"	1141 mm	3'5"
E Ground to center of hitch	484 mm	1'11"	484 mm	1'11"	558 mm	1'10"
F Tractor to pin centerline	889 mm	2'11"	889 mm	2'11"	655 mm	2'2"
Overall width (not shown)	965 mm	3'2"	965 mm	3'2"	1016 mm	3'4"
Drum diameter (not shown)	254 mm	10"	254 mm	10"	254 mm	10"
Weight	1020 kg	2250 lb	1465 kg	3230 lb	1360 kg	3000 lb
Oil refill capacity	8 L	2 U.S. gal	72 L	19 U.S. gal	72 L	19 U.S. gal
Wire rope diameter:						
Recommended	22 mm	7/8"	22 mm	7/8"	22 mm	7/8"
Optional	25 mm	1"	25 mm	1"	25 mm	1"
Drum capacity:						
Recommended rope	87 m	287'	87 m	287'	87 m	287'
Optional rope	68 m	223'	68 m	223'	68 m	223'
Wire rope ferrule size (OD)	51 mm	2"	51 mm	2"	51 mm	2"
Wire rope ferrule size (length)	57 mm	2 1/4"	57 mm	2 1/4"	57 mm	2 1/4"

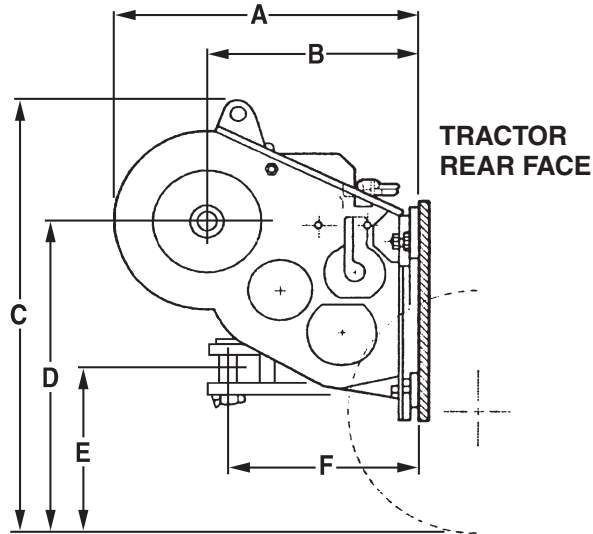

WINCH MODEL	W6G		W8L			
	D6T		D7G Series 2		D7R Series 2	
Winch drive	PTO		PTO		PTO	
Winch type	Standard		Standard		Standard	
A Tractor to rear of winch	1244 mm	4'1"	864 mm	2'10"	1245 mm	4'1"
B Tractor to drum centerline	965 mm	3'2"	584 mm	1'11"	965 mm	3'2"
C Ground to top of winch	1549 mm	5'1"	1575 mm	5'2"	1600 mm	5'3"
D Ground to drum centerline	1193 mm	4'1"	1194 mm	3'11"	1219 mm	4'0"
E Ground to center of hitch	711 mm	2'4"	559 mm	1'10"	610 mm	2'0"
F Tractor to pin centerline	940 mm	3'1"	686 mm	2'3"	914 mm	3'2"
Overall width (not shown)	965 mm	3'2"	1041 mm	3'5"	1041 mm	3'5"
Drum diameter (not shown)	254 mm	10"	305 mm	12"	305 mm	12"
Weight	1520 kg	<b>3350 lb</b>	1338 kg	<b>2950 lb</b>	1587 kg	<b>3500 lb</b>
Oil refill capacity	72 L	<b>19 U.S. gal</b>	79 L	<b>21 U.S. gal</b>	79 L	<b>21 U.S. gal</b>
Wire rope diameter:						
Recommended	22 mm	7/8"	25 mm	1"	25 mm	1"
Optional	25 mm	1"	28 mm	1 1/8"	28 mm	1 1/8"
Drum capacity:						
Recommended rope	87 m	<b>287'</b>	84 m	<b>275'</b>	84 m	<b>275'</b>
Optional rope	68 m	<b>223'</b>	67 m	<b>220'</b>	67 m	<b>220'</b>
Wire rope ferrule size (OD)	51 mm	2"	57 mm	2 1/4"	57 mm	2 1/4"
Wire rope ferrule size (length)	57 mm	2 1/4"	60 mm	2 3/8"	60 mm	2 3/8"

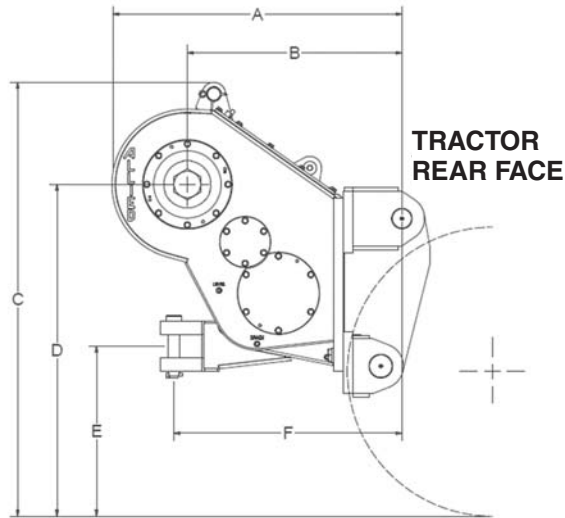

WINCH MODEL	H8L	
TRACTOR MODEL	D7E	
Winch drive	Hydraulic	
Winch type	Hi-Performance	
A Tractor to rear of winch	1097 mm	3'7"
B Tractor to drum centerline	813 mm	2'8"
C Ground to top of winch	1651 mm	5'5"
D Ground to drum centerline	1270 mm	4'2"
E Ground to center of hitch	660 mm	2'2"
F Tractor to pin centerline	864 mm	2'10"
Overall width (not shown)	1067 mm	3'6"
Drum diameter (not shown)	305 mm	12"
Weight	1511 kg	3330 lb
Oil refill capacity	19 L	5 U.S. gal
Wire rope diameter:		
Recommended	25 mm	1"
Optional	28 mm	1 1/8"
Drum capacity:		
Recommended rope	102 m	334'
Optional rope	81 m	267'
Wire rope ferrule size (OD)	57 mm	2 1/4"
Wire rope ferrule size (length)	60 mm	2 3/8"

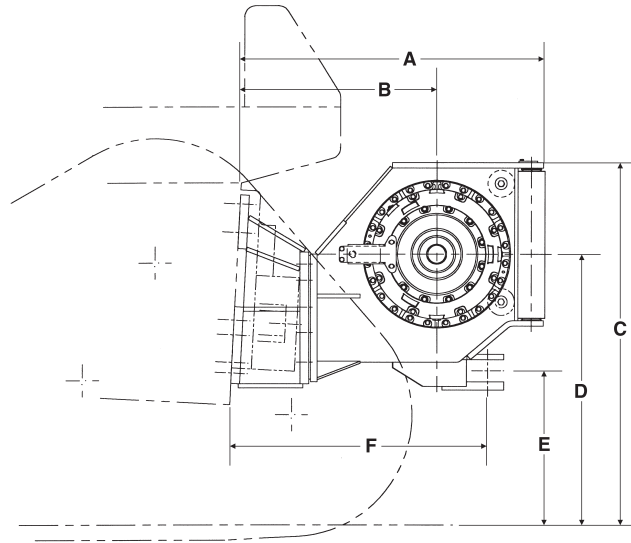

WINCH MODEL	PA90		H110B		PA110B	
TRACTOR MODEL	D6T		D7R Series 2		D7R Series 2	
Tractor transmission	Powershift		Powershift		Powershift	
Winch drive	Hydraulic (High Power)		Hydraulic (Ripper)		Hydraulic (High Power)	
A Tractor to rear of winch	1380 mm	4'6.4"	1585 mm	5'2.4"	1435 mm	4'8.5"
B Tractor to drum centerline	870 mm	2'10.3"	1075 mm	3'6.3"	925 mm	3'0.4"
C Ground to top of winch	1680 mm	5'6.1"	1695 mm	5'6.8"	1695 mm	5'6.8"
D Ground to drum centerline	1235 mm	4'0.6"	1255 mm	4'1.5"	1255 mm	4'1.5"
E Ground to center of hitch	670 mm	2'2.4"	705 mm	2'3.8"	705 mm	2'3.8"
F Tractor to drawbar pin centerline	1160 mm	3'7.7"	1370 mm	4'5.9"	1220 mm	4'0"
Winch width (not shown) <sup>1</sup>	1090 mm	3'7"	1160 mm	3'9.6"	1160 mm	3'9.6"
Drum diameter (not shown)	320 mm	1'0.5"	320 mm	1'0.5"	320 mm	1'0.5"
Weight <sup>2</sup>	1500 kg	<b>3300 lb</b>	1790 kg	<b>3950 lb</b>	1790 kg	<b>3950 lb</b>
Oil refill capacity	12 L	<b>3.125 U.S. gal</b>	15 L	<b>4 U.S. gal</b>	15 L	<b>4 U.S. gal</b>
Wire rope diameter:						
Recommended	26 mm	1"	28 mm	1.13"	28 mm	1.13"
Optional	28 mm	1.13"	32 mm	1.25"	32 mm	1.25"
Maximum theoretical drum capacity: <sup>3</sup>						
Recommended rope	69 m	<b>226'</b>	78 m	<b>257'</b>	78 m	<b>257'</b>
Optional rope	55 m	<b>180'</b>	62 m	<b>204'</b>	62 m	<b>204'</b>
Maximum recommended drum capacity: <sup>4</sup>						
Recommended rope	57 m	<b>186'</b>	55 m	<b>182'</b>	55 m	<b>182'</b>
Optional rope	39 m	<b>128'</b>	36 m	<b>118'</b>	36 m	<b>118'</b>
Wire rope ferrule size (OD)	60 mm	<b>2.38"</b>	60 mm	<b>2.38"</b>	60 mm	<b>2.38"</b>
Wire rope ferrule size (length)	70 mm	<b>2.75"</b>	70 mm	<b>2.75"</b>	70 mm	<b>2.75"</b>

<sup>1</sup> Width does not include mounting brackets/adapters (if any).

<sup>2</sup> Weight shown is base winch only. Does not include mounting arrangement, control arrangement, oil, or wire rope.

<sup>3</sup> Per SAE J1158.

<sup>4</sup> Per SAE J706 (K=9).

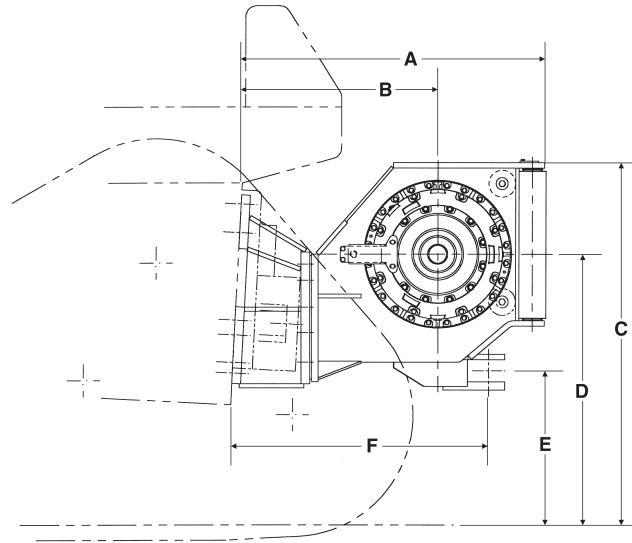

WINCH MODEL	H140		PA140			
TRACTOR MODEL	D8T		D8T		D9T	
Tractor transmission	Powershift		Powershift		Powershift	
Winch drive	Hydraulic (Ripper)		Hydraulic (High Power)		Hydraulic (High Power)	
A Tractor to rear of winch	1585 mm	5'2.4"	1435 mm	4'8.5"	1620 mm	5'3.8"
B Tractor to drum centerline	1075 mm	3'6.3"	925 mm	3'0.4"	1110 mm	3'7.7"
C Ground to top of winch	1715 mm	5'7.5"	1715 mm	5'7.5"	1740 mm	5'8.4"
D Ground to drum centerline	1275 mm	4'2.1"	1275 mm	4'2.1"	1300 mm	4'3.2"
E Ground to center of hitch	725 mm	2'4.5"	725 mm	2'4.5"	750 mm	2'5.5"
F Tractor to drawbar pin centerline	1370 mm	4'5.9"	1220 mm	4'0"	1350 mm	4'5.2"
Winch width (not shown) <sup>1</sup>	1160 mm	3'9.6"	1160 mm	3'9.6"	1160 mm	3'9.6"
Drum diameter (not shown)	320 mm	2'0.5"	320 mm	12.5"	320 mm	12.5"
Weight <sup>2</sup>	1790 kg	3950 lb	1790 kg	3950 lb	1790 kg <sup>5</sup>	3950 lb <sup>5</sup>
Oil refill capacity	15 L	4 U.S. gal	15 L	4 U.S. gal	15 L	4 U.S. gal
Wire rope diameter:						
Recommended	28 mm	1.13"	28 mm	1.13"	28 mm	1.13"
Optional	32 mm	1.25"	32 mm	1.25"	32 mm	1.25"
Maximum theoretical drum capacity: <sup>3</sup>						
Recommended rope	78 m	257'	78 m	257'	78 m	257'
Optional rope	62 m	204'	62 m	204'	62 m	204'
Maximum recommended drum capacity: <sup>4</sup>						
Recommended rope	55 m	182'	55 m	182'	55 m	182'
Optional rope	36 m	118'	36 m	118'	36 m	118'
Wire rope ferrule size (OD)	60 mm	2.38"	60 mm	2.38"	60 mm	2.38"
Wire rope ferrule size (length)	70 mm	2.75"	70 mm	2.75"	70 mm	2.75"

<sup>1</sup> Width does not include mounting brackets/adapters (if any).

<sup>2</sup> Weight shown is base winch only. Does not include mounting arrangement, control arrangement, oil, or wire rope.

<sup>3</sup> Per SAE J1158.

<sup>4</sup> Per SAE J706 (K=9).

<sup>5</sup> 3700 kg (**8150 lb**) with counterweight.

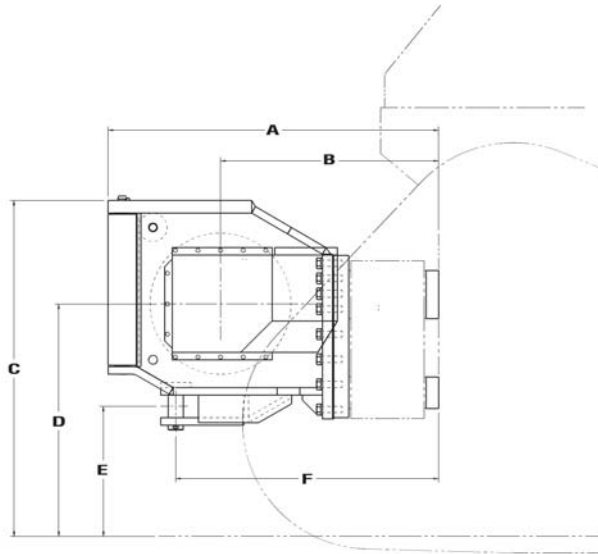

WINCH MODEL	H200			
TRACTOR MODEL	D8T		D9T	
Tractor transmission	Powershift		Powershift	
Winch drive	Hydraulic (High Power)		Hydraulic (High Power)	
A Tractor to rear of winch	1460 mm	57.5"	1645 mm	64.8"
B Tractor to drum centerline	960 mm	37.7"	1075 mm	42.4"
C Ground to top of winch	1760 mm	69.4"	1735 mm	68.3"
D Ground to drum centerline	1240 mm	48.8"	1215 mm	47.9"
E Ground to center of hitch	725 mm	28.5"	700 mm	27.5"
F Tractor to drawbar pin centerline	1170 mm	46.1"	1305 mm	51.3"
Winch width (not shown) <sup>1</sup>	1400 mm	55"	1400 mm	55"
Drum diameter (not shown)	380 mm	15"	380 mm	15"
Weight <sup>2</sup>	3180 kg	7015 lb	3180 kg <sup>5</sup>	7015 lb <sup>5</sup>
Oil refill capacity	16.5 L	4.4 U.S. gal	16.5 L	4.4 U.S. gal
Wire rope diameter:				
Recommended	35 mm	1.38"	35 mm	1.38"
Optional	38 mm	1.5"	38 mm	1.5"
Maximum theoretical drum capacity: <sup>3</sup>				
Recommended rope	81 m	266'	81 m	266'
Optional rope	68 m	224'	68 m	224'
Maximum recommended drum capacity: <sup>4</sup>				
Recommended rope	64 m	211'	64 m	211'
Optional rope	42 m	138'	42 m	138'
Wire rope ferrule size (OD)	71 mm	2.81"	71 mm	2.81"
Wire rope ferrule size (length)	79 mm	3.12"	79 mm	3.12"

<sup>1</sup> Width does not include mounting brackets/adapters (if any).

<sup>2</sup> Weight shown is base winch only. Does not include mounting arrangement, control arrangement, oil, or wire rope.

<sup>3</sup> Per SAE J1158.

<sup>4</sup> Per SAE J706 (K=9).

<sup>5</sup> 5080 kg (11,200 lb) with counterweight.



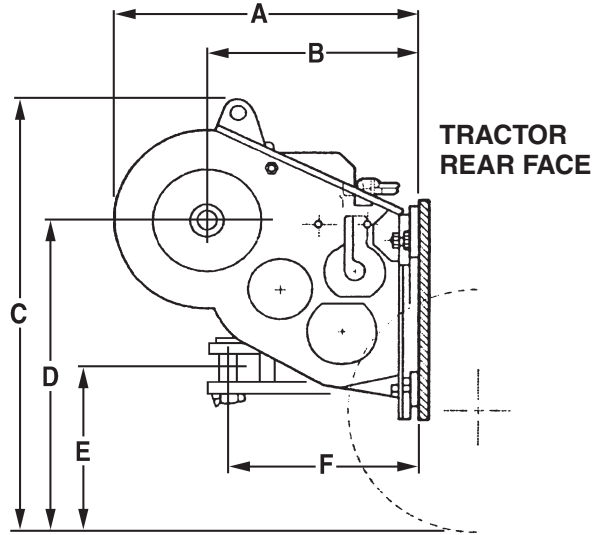

WINCH MODEL	W12E					
TRACTOR MODEL	D8T/583T/587T		D9R/D9T		D10R/D10T	
Winch drive	PTO		PTO		PTO	
Winch type	Standard		Standard		Standard	
A Tractor to rear of winch	1473 mm	4'10"	1422 mm	4'8"	1422 mm	4'8"
B Tractor to drum centerline	1143 mm	3'9"	1117 mm	3'8"	1117 mm	3'8"
C Ground to top of winch	1752 mm	5'9"	1675 mm	5'6"	2057 mm	6'9"
D Ground to drum centerline	1346 mm	4'4"	1270 mm	4'2"	1651 mm	5'5"
E Ground to center of hitch	685 mm	2'3"	610 mm	2'0"	991 mm	3'3"
F Tractor to pin centerline	1270 mm	4'2"	1219 mm	4'0"	1219 mm	4'0"
Overall width (not shown)	1219 mm	4'0"	1219 mm	4'0"	1219 mm	4'0"
Drum diameter (not shown)	355 mm	14"	355 mm	14"	355 mm	14"
Weight	2860 kg	6300 lb	2766 kg	6100 lb	3766 kg	8300 lb
Oil refill capacity	114 L	30 U.S. gal	114 L	30 U.S. gal	114 L	30 U.S. gal
Wire rope diameter:						
Recommended	28 mm	1 1/8"	28 mm	1 1/8"	28 mm	1 1/8"
Optional	32 mm	1 1/4"	32 mm	1 1/4"	32 mm	1 1/4"
Drum capacity:						
Recommended rope	69 m	228'	69 m	228'	69 m	228'
Optional rope	55 m	181'	55 m	181'	55 m	181'
Wire rope ferrule size (OD)	57 mm	2 1/4"	57 mm	2 1/4"	57 mm	2 1/4"
Wire rope ferrule size (length)	60 mm	2 3/8"	60 mm	2 3/8"	60 mm	2 3/8"

WINCH MODEL		PA40	PA50
TRACTOR MODEL		D3K, D4K, D5K	D6K
Tractor transmission . . . . .		Hydrostatic	Hydrostatic
Winch drive . . . . .		Hydrostatic	Hydrostatic
<b>British Units of Measure</b>			
Bare Drum	Maximum line pull <sup>(1)</sup> . . . . .lb	40,000	50,000
	Rated line speed <sup>(2)</sup> . . . . .fpm	49	45
	Maximum line speed <sup>(3)</sup> . . . . .fpm	132	124
Full Drum <sup>(4)</sup>	Maximum line pull <sup>(1)</sup> . . . . .lb	25,000	26,000
	Rated line speed <sup>(2)</sup> . . . . .fpm	78	83
	Maximum line speed <sup>(3)</sup> . . . . .fpm	207	230
<b>Metric Units of Measure</b>			
Bare Drum	Maximum line pull <sup>(1)</sup> . . . . .kN	177.9	222.4
	Rated line speed <sup>(2)</sup> . . . . .m/min	15	14
	Maximum line speed <sup>(3)</sup> . . . . .m/min	40	38
Full Drum <sup>(4)</sup>	Maximum line pull <sup>(1)</sup> . . . . .kN	111.2	115.7
	Rated line speed <sup>(2)</sup> . . . . .m/min	24	25
	Maximum line speed <sup>(3)</sup> . . . . .m/min	63	70

<sup>(1)</sup>"Maximum line pull" is lesser of winch catalog rating or calculated maximum line pull at maximum tractor hydraulic system pressure.

<sup>(2)</sup>"Rated line speed" is calculated maximum line speed at maximum line pull.

<sup>(3)</sup>"Maximum line speed" is calculated maximum no-load line speed at maximum tractor hydraulic system flow.

<sup>(4)</sup>"Full Drum" as defined by SAE J1158.

WINCH MODEL		H60	PA90	
TRACTOR MODEL		D6N	D6T	D7E
Tractor transmission . . . . .		Powershift	Powershift	Electric
Winch drive . . . . .		Hydraulic (Ripper)	Hydraulic (High Power)	Hydraulic (High Power)
<b>British Units of Measure</b>				
Bare Drum	Maximum line pull <sup>(1)</sup> . . . . .lb	60,000	90,000	90,000
	Rated line speed <sup>(2)</sup> . . . . .fpm	33	35	32
	Maximum line speed <sup>(3)</sup> . . . . .fpm	99	68	63
Full Drum <sup>(4)</sup>	Maximum line pull <sup>(1)</sup> . . . . .lb	35,000	53,600	53,600
	Rated line speed <sup>(2)</sup> . . . . .fpm	56	59	53
	Maximum line speed <sup>(3)</sup> . . . . .fpm	170	114	106
<b>Metric Units of Measure</b>				
Bare Drum	Maximum line pull <sup>(1)</sup> . . . . .kN	266.9	400.3	400.3
	Rated line speed <sup>(2)</sup> . . . . .m/min	10	10	10
	Maximum line speed <sup>(3)</sup> . . . . .m/min	30	20	19
Full Drum <sup>(4)</sup>	Maximum line pull <sup>(1)</sup> . . . . .kN	155.7	238.4	238.4
	Rated line speed <sup>(2)</sup> . . . . .m/min	17	18	16
	Maximum line speed <sup>(3)</sup> . . . . .m/min	52	34	32

<sup>(1)</sup>"Maximum line pull" is lesser of winch catalog rating or calculated maximum line pull at maximum tractor hydraulic system pressure.

<sup>(2)</sup>"Rated line speed" is calculated maximum line speed at maximum line pull.

<sup>(3)</sup>"Maximum line speed" is calculated maximum no-load line speed at maximum tractor hydraulic system flow.

<sup>(4)</sup>"Full Drum" as defined by SAE J1158.

WINCH MODEL		H110B	PA110B	H140
TRACTOR MODEL		D7R Series 2	D7R Series 2	D8T
Tractor transmission . . . . .		Powershift	Powershift	Powershift
Winch drive . . . . .		Hydraulic (Ripper)	Hydraulic (High Power)	Hydraulic (Ripper)
<b>British Units of Measure</b>				
Bare Drum	Maximum line pull <sup>(1)</sup> . . . . . .lb	101,000	110,000	140,000
	Rated line speed <sup>(2)</sup> . . . . . .fpm	24	33	19
	Maximum line speed <sup>(3)</sup> . . . . . .fpm	51	100	38
Full Drum <sup>(4)</sup>	Maximum line pull <sup>(1)</sup> . . . . . .lb	61,000	66,500	84,600
	Rated line speed <sup>(2)</sup> . . . . . .fpm	39	54	31
	Maximum line speed <sup>(3)</sup> . . . . . .fpm	84	165	63
<b>Metric Units of Measure</b>				
Bare Drum	Maximum line pull <sup>(1)</sup> . . . . . .kN	449.3	489.3	622.8
	Rated line speed <sup>(2)</sup> . . . . . .m/min	7	10	6
	Maximum line speed <sup>(3)</sup> . . . . . .m/min	15	30	11
Full Drum <sup>(4)</sup>	Maximum line pull <sup>(1)</sup> . . . . . .kN	271.3	295.8	376.3
	Rated line speed <sup>(2)</sup> . . . . . .m/min	12	16	9
	Maximum line speed <sup>(3)</sup> . . . . . .m/min	25	50	19

<sup>(1)</sup>"Maximum line pull" is lesser of winch catalog rating or calculated maximum line pull at maximum tractor hydraulic system pressure.

<sup>(2)</sup>"Rated line speed" is calculated maximum line speed at maximum line pull.

<sup>(3)</sup>"Maximum line speed" is calculated maximum no-load line speed at maximum tractor hydraulic system flow.

<sup>(4)</sup>"Full Drum" as defined by SAE J1158.

WINCH MODEL		PA140	
TRACTOR MODEL		D8T	D9T
Tractor transmission . . . . .		Powershift	Powershift
Winch drive . . . . .		Hydraulic (High Power)	Hydraulic (High Power)
<b>British Units of Measure</b>			
Bare Drum	Maximum line pull <sup>(1)</sup> . . . . . .lb	140,000	140,000
	Rated line speed <sup>(2)</sup> . . . . . .fpm	23	23
	Maximum line speed <sup>(3)</sup> . . . . . .fpm	46	46
Full Drum <sup>(4)</sup>	Maximum line pull <sup>(1)</sup> . . . . . .lb	84,600	84,600
	Rated line speed <sup>(2)</sup> . . . . . .fpm	38	38
	Maximum line speed <sup>(3)</sup> . . . . . .fpm	76	76
<b>Metric Units of Measure</b>			
Bare Drum	Maximum line pull <sup>(1)</sup> . . . . . .kN	622.8	622.8
	Rated line speed <sup>(2)</sup> . . . . . .m/min	7	7
	Maximum line speed <sup>(3)</sup> . . . . . .m/min	14	14
Full Drum <sup>(4)</sup>	Maximum line pull <sup>(1)</sup> . . . . . .kN	376.3	376.3
	Rated line speed <sup>(2)</sup> . . . . . .m/min	11	11
	Maximum line speed <sup>(3)</sup> . . . . . .m/min	23	23

<sup>(1)</sup>"Maximum line pull" is lesser of winch catalog rating or calculated maximum line pull at maximum tractor hydraulic system pressure.

<sup>(2)</sup>"Rated line speed" is calculated maximum line speed at maximum line pull.

<sup>(3)</sup>"Maximum line speed" is calculated maximum no-load line speed at maximum tractor hydraulic system flow.

<sup>(4)</sup>"Full Drum" as defined by SAE J1158.

WINCH MODEL		PA55	PA56		PA80
TRACTOR MODEL		D6N	D6G Series 2 XL	D6T	D7G Series 2
Tractor transmission . . . . .		Powershift	Powershift	Powershift	Powershift
Winch drive . . . . .		PTO	PTO	PTO	PTO
<b>British Units of Measure</b>					
Bare Drum	Rated line pull <sup>(1)</sup> . . . . . .lb	36,600	58,700	59,100	45,100
	Maximum line pull <sup>(2)</sup> . . . . . .lb	69,200	89,800	89,800	86,900
	Rated line speed <sup>(3)</sup> . . . . . .fpm	97	70	80	107
	Maximum line speed <sup>(4)</sup> . . . . . .fpm	147	132	130	190
Full Drum <sup>(5)</sup>	Rated line pull <sup>(1)</sup> . . . . . .lb	20,900	34,200	34,400	29,900
	Maximum line pull <sup>(2)</sup> . . . . . .lb	54,100	65,400	76,300	57,500
	Rated line speed <sup>(3)</sup> . . . . . .fpm	169	120	136	161
	Maximum line speed <sup>(4)</sup> . . . . . .fpm	257	226	224	286
<i>Slow speed gearing</i>					
Bare Drum	Rated line pull <sup>(1)</sup> . . . . . .lb	50,000	70,000	70,000	—
	Maximum line pull <sup>(2)</sup> . . . . . .lb	69,200	89,800	89,800	—
	Rated line speed <sup>(3)</sup> . . . . . .fpm	40	31	35	—
	Maximum line speed <sup>(4)</sup> . . . . . .fpm	61	59	58	—
Full Drum <sup>(5)</sup>	Rated line pull <sup>(1)</sup> . . . . . .lb	50,000	70,000	70,000	—
	Maximum line pull <sup>(2)</sup> . . . . . .lb	69,200	89,800	89,800	—
	Rated line speed <sup>(3)</sup> . . . . . .fpm	70	56	63	—
	Maximum line speed <sup>(4)</sup> . . . . . .fpm	107	104	103	—
<b>Metric Units of Measure</b>					
Bare Drum	Rated line pull <sup>(1)</sup> . . . . . .kN	162.8	261.1	262.9	200.6
	Maximum line pull <sup>(2)</sup> . . . . . .kN	307.8	399.5	399.5	386.6
	Rated line speed <sup>(3)</sup> . . . . . .m/min	30	21	24	33
	Maximum line speed <sup>(4)</sup> . . . . . .m/min	45	40	40	58
Full Drum <sup>(5)</sup>	Rated line pull <sup>(1)</sup> . . . . . .kN	93.0	152.1	153.0	133.0
	Maximum line pull <sup>(2)</sup> . . . . . .kN	240.6	290.9	153.9	255.8
	Rated line speed <sup>(3)</sup> . . . . . .m/min	52	37	41	49
	Maximum line speed <sup>(4)</sup> . . . . . .m/min	78	69	68	87
<i>Slow speed gearing</i>					
Bare Drum	Rated line pull <sup>(1)</sup> . . . . . .kN	222.4	311.4	311.4	—
	Maximum line pull <sup>(2)</sup> . . . . . .kN	307.8	399.5	399.5	—
	Rated line speed <sup>(3)</sup> . . . . . .m/min	12	9	11	—
	Maximum line speed <sup>(4)</sup> . . . . . .m/min	19	18	18	—
Full Drum <sup>(5)</sup>	Rated line pull <sup>(1)</sup> . . . . . .kN	222.4	311.4	311.4	—
	Maximum line pull <sup>(2)</sup> . . . . . .kN	307.8	399.5	399.5	—
	Rated line speed <sup>(3)</sup> . . . . . .m/min	21	17	19	—
	Maximum line speed <sup>(4)</sup> . . . . . .m/min	33	32	31	—

<sup>(1)</sup>"Rated line pull" is lesser of winch catalog rating or calculated line pull at maximum tractor PTO output power.  
<sup>(2)</sup>"Maximum line pull" is lesser of calculated line pull at maximum tractor PTO output torque or catalog breaking strength of maximum optional size new IWRC IPS wire rope.  
<sup>(3)</sup>"Rated line speed" is calculated line speed at maximum tractor PTO output power.  
<sup>(4)</sup>"Maximum line speed" is calculated no-load line speed at maximum tractor engine PTO output speed.  
<sup>(5)</sup>"Full Drum" as defined by SAE J1158.

WINCH MODEL		H200	
TRACTOR MODEL		D8T	D9T
Tractor transmission . . . . .		Powershift	Powershift
Winch drive . . . . .		Hydraulic (High Power)	Hydraulic (High Power)
<b>British Units of Measure</b>			
Bare Drum	Maximum line pull <sup>(1)</sup> . . . . .lb	180,000	200,000
	Rated line speed <sup>(2)</sup> . . . . .fpm	17	17
	Maximum line speed <sup>(3)</sup> . . . . .fpm	38	38
Full Drum <sup>(4)</sup>	Maximum line pull <sup>(1)</sup> . . . . .lb	112,000	124,500
	Rated line speed <sup>(2)</sup> . . . . .fpm	27	27
	Maximum line speed <sup>(3)</sup> . . . . .fpm	61	61
<b>Metric Units of Measure</b>			
Bare Drum	Maximum line pull <sup>(1)</sup> . . . . .kN	800.7	889.6
	Rated line speed <sup>(2)</sup> . . . . .m/min	5	5
	Maximum line speed <sup>(3)</sup> . . . . .m/min	11	11
Full Drum <sup>(4)</sup>	Maximum line pull <sup>(1)</sup> . . . . .kN	498.2	553.8
	Rated line speed <sup>(2)</sup> . . . . .m/min	8	8
	Maximum line speed <sup>(3)</sup> . . . . .m/min	18	18

<sup>(1)</sup>"Maximum line pull" is lesser of winch catalog rating or calculated maximum line pull at maximum hydraulic system pressure.  
<sup>(2)</sup>"Rated line speed" is calculated maximum line speed at maximum hydraulic system pressure and flow with winch motor at maximum displacement.  
<sup>(3)</sup>"Maximum line speed" is calculated maximum no-load line speed at maximum hydraulic system flow with winch motor at minimum displacement.  
<sup>(4)</sup>"Full Drum" as defined by SAE J1158.

WINCH MODEL		H4AT	H4AH	H5CT	H5CH
<b>TRACTOR MODEL</b>		<b>D3K, D4K, D5K</b>	<b>D3K, D4K, D5K</b>	<b>D6K</b>	<b>D6K</b>
Winch drive .....		Ripper Hydraulics	Allied hi-flow pump	Ripper Hydraulics	Allied hi-flow pump
Winch type .....		Rescue	Hi-Performance	Rescue	Hi-Performance
<b>British Units of Measure</b>					
Bare Drum	Maximum line pull .....	32,150	38,600	66,700	59,750
	Line speed .....	34	94	25	97
	Typical line pull .....	20,000	20,000	30,000	30,000
	Maximum line speed .....	46	100	52	128
Full Drum	Maximum line pull .....	18,350	22,050	35,950	32,200
	Line speed .....	16	98	47	70
	Typical line pull .....	18,350	20,000	30,000	30,000
	Maximum line speed .....	81	176	97	237
<b>Metric Units of Measure</b>					
Bare Drum	Maximum line pull .....	143.1	171.8	296.8	265.9
	Line speed .....	10.4	28.7	7.6	29.6
	Typical line pull .....	89.0	89.0	133.5	133.5
	Maximum line speed .....	21	45	24	58
Full Drum	Maximum line pull .....	81.7	98.1	160.0	143.3
	Line speed .....	4.9	29.9	14.3	21.3
	Typical line pull .....	81.7	89.0	133.5	133.5
	Maximum line speed .....	37	80	44	108

Performance based on standard gear ratio. Optional gear ratios available for different line speed and line pull requirements.

WINCH MODEL		W6G	W6F	W6G
TRACTOR MODEL		D6N	D6G Series 2	D6T
Winch drive .....		PTO	PTO	PTO
Winch type .....		Standard	Standard	Standard
<b>British Units of Measure</b>				
Bare Drum	Maximum line pull .....	88,800*	88,800*	88,800*
	Line speed .....	71	89	67
	Typical line pull .....	40,000	40,000	40,000
	Maximum line speed .....	85	113	79
Full Drum	Maximum line pull .....	88,800	69,000	88,800
	Line speed .....	90	94	101
	Typical line pull .....	40,000	40,000	40,000
	Maximum line speed .....	154	205	143
<b>Metric Units of Measure</b>				
Bare Drum	Maximum line pull .....	395.2*	395.2*	395.2*
	Line speed .....	21.6	27.1	20.4
	Typical line pull .....	178.0	178.0	178.0
	Maximum line speed .....	39	51	36
Full Drum	Maximum line pull .....	395.2	307.1	395.2
	Line speed .....	27.4	28.7	30.8
	Typical line pull .....	178.0	178.0	178.0
	Maximum line speed .....	70	93	65

Performance based on standard gear ratio. Optional gear ratios available for different line speed and line pull requirements.  
 \*Line pull limited by rated breaking strength of wire rope.

WINCH MODEL		W8L		H8L
TRACTOR MODEL		D7G Series 2	D7R Series 2/ 572R Series 2	D7E
Winch drive	.....	PTO	PTO	Hydraulic
Winch type	.....	Standard	Standard	Hi-Performance
<b>British Units of Measure</b>				
Bare Drum	Maximum line pull	103,600	112,500*	112,500*
	Line speed	102	122	29
	Typical line pull	50,000	50,000	50,000
	Maximum line speed	170	168	65
Full Drum	Maximum line pull	63,600	81,700	72,600
	Line speed	75	115	47
	Typical line pull	50,000	50,000	50,000
	Maximum line speed	275	275	106
<b>Metric Units of Measure</b>				
Bare Drum	Maximum line pull	461.0	500.6*	500.6*
	Line speed	31.1	37.2	8.8
	Typical line pull	222.5	222.5	222.5
	Maximum line speed	51.8	51.2	19.8
Full Drum	Maximum line pull	283.0	363.6	323.1
	Line speed	22.9	35.1	14.3
	Typical line pull	222.5	222.5	222.5
	Maximum line speed	83.8	83.8	32.3

Performance based on standard gear ratio. Optional gear ratios available for different line speed and line pull requirements.  
 \*Line pull limited by rated breaking strength of wire rope.



WINCH MODEL		W12E		
TRACTOR MODEL		D8T/583T/587T	D9T	D10T
Winch drive		PTO	PTO	PTO
Winch type		Standard	Standard	Standard
<b>British Units of Measure</b>				
Bare Drum	Maximum line pull	138,800*	138,800*	138,800*
	Line speed	52	55	53
	Typical line pull	80,000	80,000	80,000
	Maximum line speed	59	60	58
Full Drum	Maximum line pull	138,800	138,800	138,800
	Line speed	78	82	81
	Typical line pull	80,000	80,000	80,000
	Maximum line speed	92	93	91
<b>Metric Units of Measure</b>				
Bare Drum	Maximum line pull	617.7*	617.7*	617.7*
	Line speed	15.8	16.8	16.2
	Typical line pull	356.0	356.0	356.0
	Maximum line speed	18.0	18.3	17.7
Full Drum	Maximum line pull	617.7	617.7	617.7
	Line speed	23.8	25.0	24.7
	Typical line pull	356.0	356.0	356.0
	Maximum line speed	28.0	28.3	27.7

Performance based on standard gear ratio. Optional gear ratios available for different line speed and line pull requirements.  
 \*Line pull limited by rated breaking strength of wire rope.

# MOTOR GRADERS

## CONTENTS

Industries Served .....	2-1
Features .....	2-2
Applications .....	2-7
Specifications: Standard Versions .....	2-10
Specifications: Global Versions .....	2-12
Travel Speeds .....	2-16
All Wheel Drive (AWD) .....	2-17
Mid Mount and Front Mount Scarifiers .....	2-17
Rear Ripper and Rear Ripper/Scarifier .....	2-18
Production .....	2-20
Formulas .....	2-24
Extreme Slope Operation .....	2-25
Work Tools .....	2-26

## INDUSTRIES SERVED

The motor grader is one of the most versatile work tools in the Caterpillar® product line. The M Series machines are used in numerous applications within a wide range of industries. The major industries using Cat® motor graders, along with the typical applications within each, are summarized below.

### ● Heavy Construction

- Highway Construction
- Paving/Resurfacing
- Airport Construction
- Railroad Construction
- Dam and Levee Construction
- Haul Road Maintenance

### ● Governmental

- Road Maintenance
- Road Construction
- Ditch Building/Cleaning
- Snow Removal

### ● Building Construction

- Residential Construction
- Commercial Construction
- Industrial Construction
- Sewer and Water Systems

### ● Industrial

- Waste Disposal
- Pipeline Construction

### ● Mining

- Haul Road Maintenance
- Snow Removal

### ● Forestry

- Access Road Construction
- Forest Development
- Snow Removal
- Haul Road Maintenance

- **Geographic Versions** — Cat Motor Graders were specifically designed to meet the needs of different geographic regions and regulations. K Series Versions for less regulated locations and M Series Global Versions are available with an assortment of standard features and optional equipment. All motor graders feature advanced electronically controlled Cat engines, power train components, hydraulics and machine structures.

**FEATURES, M Series Motor Graders:**

Building on the strong heritage of the H Series, the M Series delivers multiple technological breakthroughs, setting the new standard for motor graders. The H Series has been the industry standard in a variety of heavy construction, mining, road building and governmental applications. The M Series continues this tradition, incorporating revolutionary, customer-driven enhancements by:

- Improving ease of operation and operation training time
- Offering best-in-class operator station and unmatched visibility
- Delivering maximum productivity
- Improving availability and decreasing maintenance time

The M Series line includes ten models: 120, 120 AWD, 140, 140 AWD, 160, 160 AWD, 14, 16, 24. The 120M through 140M meet construction, road building, and governmental applications. All Wheel Drive models improve traction in poor underfoot conditions such as snow, mud, and sand. The 160M and 240M meet the specialized needs of large mining customers.

- **Operation Station:** The 120M through 160M models feature a revolutionary cab design that provides unmatched comfort, visibility and ease of use, making the operator more confident and productive. The M Series provides a comfortable environment to keep the operator alert and focused. The interior noise level is maintained between 70 and 74 dB(A) with the doors and windows closed.

**Ease of Operation.** The revolutionary joystick controls and exceptional visibility make the M Series easier to operate without sacrificing control. The intuitive joystick control pattern allows both new and experienced operators to become productive quickly. Logical grouping of hydraulic functions in the joysticks allow any operator to easily control several functions at the same time. This allows the operator to be more productive and remain comfortable throughout the work shift.

**Advanced Joystick Controls.** Two electro-hydraulic joysticks reduce hand and wrist movement as much as 78% compared to conventional lever controls for greatly enhanced operator efficiency. The intuitive pattern is easy to learn and provides the precise implement control to allow both new and experienced operators to become productive quickly. Logical grouping of hydraulic functions in the joysticks allow any operator to control several functions at the same time for more productivity.

**Visibility.** The 120M through 160M models boast excellent visibility to the work area, made possible with angled cab doors, a tapered engine enclosure and a patented sloped rear window. Ample glass area and carefully placed components provide excellent visibility to enhance operator confidence and productivity in all motor grader applications. The M Series gives the operator an exceptional view forward to the blade, working surface and front tires. The M Series black glare-reducing paint on the front frame and engine enclosure enhances visibility.

**Comfort and Convenience.** Caterpillar has built the most comfortable cab in the industry by replacing the control levers and steering wheel with two joystick controls and using a deeper cab design to give more leg room.

- **Drawbar, Circle and Moldboard:** The 120M through 16M models provide a broad range of extended blade positions particularly beneficial in mid-range bank sloping, ditch cutting and ditch cleaning. A long wheel base allows for an aggressive blade angle permitting material to roll more freely, reducing power requirements. Top-accessible drawbar wear inserts and the shimless moldboard retention system make DCM adjustments fast and simple, delivering more precise material control while lowering operating costs.

**Top-Adjust Drawbar Wear Strips.** The patented top-adjust wear strips dramatically reduce drawbar/circle adjustment time. By removing the access plates on top of the drawbar, shims and wear strips can easily be added or replaced. This feature reduces service downtime and lowers overall machine operating costs.

**Shimless Moldboard Retention System.** The unique shimless moldboard retention system reduces the potential for blade chatter. Adjusting screws keep the moldboard's wear strips aligned for precise blade control and dramatic reductions in service time.

- **Power Train:** Integrated, electronically controlled systems, deliver smooth reliable performance with reduced operating costs.

**Smooth Shifting Transmission.** The M Series combines several key innovations to ensure smooth, powerful shifts throughout the gear range.

**Electronically Controlled Shifting.** The full Electronic Clutch Pressure Control (ECPC) system optimizes inching modulation and smoothes shifting between all gears and directional changes. This provides outstanding control and also extends the life of the transmission by reducing stress on gears.

**Load Compensation.** This standard feature ensures consistent shift quality regardless of blade or machine load.

**Hydraulic Brakes.** The oil bathed, multi-disc service brakes are hydraulically actuated, providing smooth predictable braking and lower operating costs. With brakes located at each tandem wheel, the M Series offer the largest total brake surface area in the industry, delivering dependable stopping power and longer brake life.

- **Engine:** The M Series combines power management with ACERT™ Technology to deliver maximum power and efficiency while reducing the environmental impact.

**ACERT™ Technology.** ACERT Technology allows Cat engines to supply more power per unit of displacement without causing premature wear. This breakthrough technology reduces emissions during the combustion process by using advanced technology in the air and fuel systems, in conjunction with integrated electronics. ACERT Technology enhances overall engine performance while dramatically reducing exhaust emissions.

**Power Management.** The M Series Power Management System automatically delivers an additional 3.7 kW (5 hp) in each forward gear 1st through 4th, and each reverse gear 1st through 3rd. This standard feature optimizes rimpull for all gears by balancing traction, speed and horsepower while conserving fuel. The system limits horsepower in lower gears, which helps reduce wheel slip where traction is limited. With the Variable Horsepower Plus (VHP Plus) option, an additional 3.7 kW (5 hp) is delivered in each forward gear 5th through 8th for more power at higher speeds.

**Exhaust Emissions Compliant.** The Cat ACERT Technology engines in the M Series Motor Graders meet or exceed all U.S. EPA Tier 3 and European Union Stage III A emissions control standards and meet or exceed all U.S. EPA Tier 4 Interim and European Union Stage III B emissions control standards for M2 Series machines.

- **Hydraulics:** The M Series electro-hydraulics enable advanced machine controls with precise and predictable movements.

**Advanced Electro-Hydraulic System.** The M Series incorporates a state-of-the-art electro-hydraulic system. This technology is the foundation for revolutionary changes of the machine and implement controls. Advanced joystick controls provide unmatched controllability with precise, predictable hydraulic movements and the reliability you expect from Cat products.

**Load Sensing Hydraulics (PPPC).** The time proven load-sensing system and the advanced Proportional Priority Pressure-Compensating (PPPC, or “triple-PC”) electro-hydraulic valves on the M Series are designed to provide superior implement control and enhanced machine performance in all applications. Continuous matching of hydraulic flow and pressure to power demands creates less heat and reduces power consumption.

- **Integrated Electronic Solutions:** Full systems integration optimizes machine performance and availability.

**“Smart Machine.”** The M Series fully integrates all core systems creating a “Smart Machine.” The Cat data link shares key data among systems, optimizing machine performance while preventing potential machine damage.

**AccuGrade™ Attachment Ready Option.** The AccuGrade Attachment Ready Option is fully integrated into the machine design, making installation quick and easy. Integral hydraulic and electrical components are standard on M Series (Grade Control Ready). The AccuGrade Attachment Ready Option provides additional mounting brackets, cab controls and electrical harnesses for easy installation of the Cross Slope, Sonic, Laser, GPS or ATS electronics kits.

- **Serviceability:**

**Grouped Service Points.** The M Series groups daily service points in the left side service center to help ensure proper maintenance and inspection routines.

**Extended Service Intervals.** The M Series extended service intervals, such as 500-hour engine oil changes and 4000-hour hydraulic oil changes, reduce machine service time and increase availability.

**Ecology Drains.** Conveniently located ecology drains shorten service times and help keep the environment safe by preventing spills.

**Diagnostics and Monitoring.** The M Series provides Cat Messenger as standard equipment to enhance diagnostic capabilities by displaying machine system errors and fault codes. Cat Electronic Technician is a two way communication tool that provides easy access to stored diagnostic data and lets technicians configure machine parameters through the Cat Data Link. Product Link provides a communication flow of vital machine data and location. The M Series integrates Cat Messenger, Cat Electronic Technician, and S•O•S™ analysis for easy monitoring and fast troubleshooting, keeping your machine up and running.

- **Safety.** Safety is an integral part of all machine and system designs. The M Series machines provide a safe working environment for both the operator and ground personnel. ROPS and FOPS structures meeting current SAE and ISO requirements are standard on all Global machines. Backup alarms are also standard on the M Series.

**Operator Presence System.** The Operator Presence System keeps the parking brake engaged until the operator is seated for safe operation.

**Secondary Steering System.** The standard secondary steering system automatically engages in case of a drop in steering pressure, allowing the operator to steer the machine to a stop.

**Speed Sensitive Steering.** The steering software automatically provides an infinitely variable ratio between the joystick and the steer tires, resulting in less sensitive steering as the ground-speed increases.

**Hydraulic Lockout.** A simple switch located in the cab disables all implement functions while still providing machine steering control. This safety feature is especially useful while the machine is roading.

**Circle Drive Slip Clutch.** This standard feature protects the drawbar, circle and moldboard from shock loads when the end of the blade encounters immovable objects. It also reduces the possibility of abrupt directional changes in poor traction conditions, protecting the machine, operator and surroundings.

**Blade Lift Accumulators.** This optional feature uses accumulators to help absorb impact loads to the moldboard by allowing vertical blade travel. Blade lift accumulators reduce unnecessary wear and help to avoid unintended machine movement for increased operator safety.

**Drop-Down Rear Lights.** Optional drop-down lights fold out from the rear of the machine. This creates a wider, lower profile, to be better aligned with passenger cars.

**Rearview Camera.** Visibility is further enhanced with an optional Work Area Vision System (WAVS) LCD color monitor in the cab.

- **Best Product Support:** Cat Motor Grader users are assured the best product support anywhere in the world. With industry-best parts availability, training and an offering of inspection, maintenance and repair, Cat dealers can provide the support needed to keep the machines productive.

## FEATURES, K Series Motor Graders:

### Overview

The K Series model line-up is targeted to meet customer requirements in less regulated countries. Built on the success of the Standard H Series, the K Series delivers multiple improvements in emissions control and operator features, while still maintaining the industry standard for reliability. The K Series model line-up consists of the 120K, 12K, 140K and 160K.

### Engine

- **ACERT Engine Technology:** The K Series models are equipped with Cat ACERT engine technology, which uses numerous advanced components to efficiently produce more power and fewer emissions.
- **Emissions Compliant:** The K Series machines meet or exceed US EPA Tier 2 and EU Stage II emissions regulations.
- **Power Management Strategy:** The K Series power management strategy provides an additional 7.5 kW (10 hp) increase in third and another 7.5 kW (10 hp) in fourth gear through Variable Horsepower (VHP). This allows the operator to maintain maximum rimpull while increasing ground speed and productivity.

### Power Train

- **Electronic Clutch Pressure Control (ECPC):** This standard K Series feature smoothes shifts and improves inching control. The system uses input from the transmission and operator controls to modulate the directional clutches and produce consistent shifting.
- **Autoshift:** This optional feature improves ease of operation and maximizes productivity by automatically shifting the transmission at optimal shifting points.

### Serviceability

- **Grouped Service Points:** The K Series groups daily service points in the left side service center to help ensure proper maintenance and inspection routines.
- **Diagnostic Capability:** The K Series offers an improved dash cluster to keep the operator informed of critical system conditions. Cat Electronic Technician is also offered, allowing faster diagnostic capabilities by service personnel. Product Link allows tracking of vital machine data and location, providing a convenient way to track the machine.
- **Extended Service Intervals:** Improvements in serviceability allow increased machine operation between service intervals. The machines can operate a full 500 hours between engine oil and filter changes, 4,000 hours between hydraulic oil changes, and 12,000 hours between engine coolant changes. This reduces downtime and operating expense.

## APPLICATIONS, Motor Graders:

The broad line of Cat Motor Graders allows the customer to choose a motor grader that best fits the intended application. Below is a summary of the typical motor grader applications.

### Finish Grading

This application involves preparing a roadway or site surface for future paving or other construction activity. The material being moved is usually a hard, dry base material on a solid underfoot. Finish blading is the motor grader application that requires the highest degree of accuracy. Thus, it is primarily done at low operating speeds — usually less than 5 km/h (3 mph) — in gears 1 and 2. To ensure a smooth, even finished surface, one gear is usually maintained for a given pass. Pass lengths during this application are usually less than 600 m (2000 feet) for road construction and 150 m (500 feet) for site development. Most finish blading is performed by contractors in the Heavy Construction and Building Construction industries.

### Heavy Blading

This application involves cutting, moving, and mixing material, usually in the initial stages of surface preparation. A variety of material types are moved in this manner, and the blade tip position varies accordingly. Full blade loads are usually experienced during heavy blading, since moving material is the primary goal. Pass lengths within this application vary, but are usually less than 600 m (2000 feet). Unlike finish blading, the speed of the machine is dependent on the load being moved when heavy blading material. Typical operating speeds are from 0-10 km/h (0 to 6 mph). Therefore, gears 2 through 4 are frequently used in this application. Most heavy blading activity is performed by contractors in the Heavy Construction, Governmental, Industrial, and Forestry industries.

### Site Preparation

This application involves any material cutting, moving, and mixing necessary to prepare a residential, commercial, or industrial site for construction. A variety of materials are encountered in this application. Blade loads vary depending on the activity being performed. Both heavy blading and finish blading are performed when preparing a site. Pass lengths are typically in the range of 30-300 m (100 to 1000 feet). Typical operating speeds for site preparation vary depending on whether heavy blading or finish blading activities are being performed. Most site preparation activities are performed by contractors in the Building Construction industry.

### Road Maintenance

This application involves reshaping dirt or gravel roads to maintain a crown or superelevation, or restoring the surface itself. This generally involves secondary roads maintained by governmental bodies such as townships and counties. Materials being moved in this application vary from extremely hard dirt bases to moist gravel surfaces. The typical blade load falls between that of finish blading and heavy blading. Pass lengths are frequently longer than 600 m (2000 feet) and can extend for miles. The general speed range for this application is 5-16 km/h (3 to 10 mph), corresponding to gears 2 (heavy dirt) through 5 (soft gravel). As with finish blading, accuracy of the graded surface is the primary concern in this application. Thus, frequent shifts should be avoided whenever possible. A gear should be chosen and maintained unless there is a significant change in the material being moved. Most road maintenance activities are performed by the Governmental industry.



### Haul Road Maintenance

This application of the motor grader involves reshaping haul roads at mining, construction, or forestry work sites, usually for the purpose of maintaining smooth travel surfaces for equipment. Materials being moved while maintaining haul roads vary widely. Typical blade loads are about one-third to half of full capacity. Haul roads that experience large hauling units travelling on soft material may require heavy blade loads in order to reshape the road surface. Pass lengths vary depending on the application but can extend for miles on remote forestry or large mine haul roads. The general speed range for haul road maintenance is heavily dependent on the material being moved as well as the grade of the haul road. Many mine sites are in mountainous areas, requiring haul roads with steep grades. Generally, haulroad maintenance is performed at speeds similar to those required for general road maintenance 5-16 km/h (3 to 10 mph).

A travel surface that allows for the safe and efficient movement of machinery is the ultimate goal with this motor grader application. Very precise roadway elevations and slopes are desired but less crucial than when finish blading. Most haul road maintenance activities are performed by the Mining, Heavy Construction, and Forestry industries.

### Side/Bank Slope Work

This application involves preparing side slopes or bank slopes along roadways by placing the moldboard on a sloped surface. Slopes of up to a 2:1 angle can be cut using a motor grader. Often the motor grader is operated on the level surface adjacent to the slope, and the moldboard is extended outward to the sloped surface. Fine soils are generally encountered in this application of the motor grader. Blade loads are usually less than half of the full blade capacity, and pass lengths are seldom longer than 600 m (2000 feet). A smooth-graded sloped surface is the primary concern in this application so frequent shifts should be avoided. The typical speed range is 0-6 km/h (0 to 4 mph), corresponding to a gear selection of 1 to 3. The nominal speed is heavily dependent on the type of material being moved and on the slope of the surface. Most side/bank slope work is performed by the Heavy Construction and Governmental industries.

### Ditch Building/Cleaning

This application involves cutting "V" and flat-bottom ditches for drainage purposes and rebuilding them when necessary. Due to excessive rain and/or poor material, ditches often need cleaning and reshaping. When building ditches, materials with a wide range of densities are encountered. Blade loads vary accordingly, from half to full-blade capacity. Pass lengths are usually less than 600 m (2000 feet). The primary objective is to move material in a manner that yields a ditch with the desired slope. Ditch building often involves cutting and moving material of high density. Therefore, typical speed ranges vary. Most ditch building work, however, is performed in gears 1 through 3, corresponding to a maximum speed of about 8 km/h (5 mph). Ditch cleaning usually involves blading moist materials underneath a sod cover. Blade loads are usually less than half of full blade capacity when cleaning ditches, and pass lengths are similar to those encountered in ditch building. Typical maximum speeds for this activity are similar to that of ditch building, but less of a blade load is experienced. Ditch building and cleaning activities are usually performed by the Heavy Construction and Governmental industries.

### Ripping/Scarifying

This application involves conditioning hard, rough soils before they are bladed. Shanks on the ripper and/or scarifier are pushed into the ground, thus breaking up otherwise hard surfaces. Hard materials such as asphalt can also be loosened in order to make grading operations less damaging to the moldboard. Rippers and scarifiers can also be used to mix aggregates together. The materials being ripped/scarified are usually hard and dry. Rippers generally penetrate 150-300 mm (6 to 12 inches) into the ground, while scarifiers typically penetrate to a depth of 25-200 mm (1 to 8 inches). Pass lengths are generally less than 600 m (2000 feet) for both activities. Since the material being ripped/scarified is generally hard, the typical maximum speed for this application is about 6 km/h (4 mph) gears 1-2. If the ripper/scarifier is used for mixing aggregates, the typical operating range becomes 6-20 km/h (4 to 12 mph) gears 3-6. Most ripping/scarifying activities are performed by the Heavy Construction and Governmental industries.

### Snow Removal

Snow removal is the process of cutting and removing snow or ice from the roadway. In addition to the standard motor grader moldboard, other attachments such as a snow wing, V-plow, one-way plow, or reversible plow can be used to remove the snow. The moldboard itself is the most commonly used attachment for snow plowing. It is used in areas where snow depths are low, the terrain is relatively flat, and where excessive drifting does not occur. A snow wing is a moldboard that attaches to the machine's right side. The wing's curvature lifts the snow and "wings" it off the plowed surface. The snow wing is often used in conjunction with the standard moldboard, where the moldboard cuts the material and feeds it onto the wing. V-plows are mounted in front of the motor grader and are designed to dig into and lift packed snow. The typical speed range for snow removal is 10-30 km/h (6 to 18 mph), corresponding to a gear range of 3 to 7. Snow plowing often involves lower speeds than snow removal. The typical operating range for snow plowing is 8-19 km/h (5 to 12 mph) gears 2 to 4. The majority of Snow Removal/Plowing operations are performed by the Governmental, Mining, and Forestry industries.

# Motor Graders Standard Versions

## Specifications



MODEL	120K		12K	
Net Flywheel Power: Gears 4-8	108 kW	145 hp	123 kW	165 hp
Gear 3▲	101 kW	135 hp	116 kW	155 hp
Gears 1-2▲	93 kW	125 hp	108 kW	145 hp
Operating Weight (Typical)*	13 032 kg	28,731 lb	14 334 kg	31,601 lb
Engine Model	C7 ACERT™ VHP		C7 ACERT VHP	
Rated Engine RPM	2000		2000	
No. of Cylinders	6		6	
Displacement	7.2 L	439 in³	7.2 L	439 in³
Max. Torque	50%		50%	
No. of Speeds Forward/Reverse	8/6		8/6	
Top Speed: Forward	45.7 km/h	28.4 mph	44.8 km/h	27.9 mph
Reverse	36.1 km/h	22.4 mph	35.4 km/h	22 mph
Std. Tires — Front and Rear	13.00-24 (12 PR) (G-2)		13.00-24 (12 PR) (G-2)	
Front Axle/Steering:				
Oscillation Angle	32°		32°	
Wheel Lean Angle	18°		18°	
Steering Angle	47.5°		47.5°	
Articulation Angle	20°		20°	
Minimum Turning Radius**	7.3 m	23'10"	7.5 m	24'7"
Front Frame Section Modulus:				
Min.	1619 cm²	99 in²	2083 cm²	127 in²
Max.	3681 cm²	225 in²	4785 cm²	291 in²
No. Circle Support Shoes	4		6	
Hydraulics: Pump Type	Variable Piston		Variable Piston	
Max. Pump Flow	205.8 L/min	54.4 gpm	205.8 L/min	54.4 gpm
Reservoir Tank Capacity	55 L	14.5 U.S. gal	55 L	14.5 U.S. gal
Implement Pressure: Max.	25 500 kPa	3699 psi	25 500 kPa	3699 psi
Min.	3600 kPa	522 psi	3600 kPa	522 psi
Electrical:				
System Size	24V		24V	
Std. Battery CCA @ 0° F	750		750	
Std. Alternator	95 amp		95 amp	
GENERAL DIMENSIONS:				
Height (to top of ROPS)	3.33 m	10'11"	3.32 m	10'11"
Height (No Cab/Canopy)**	2.88 m	9'6"	3.02 m	9'11"
Overall Length	8.24 m	27'0"	8.47 m	27'9"
With Ripper and Pushplate	9.77 m	32'1"	10.01 m	32'10"
Wheelbase	5.87 m	19'3"	6.09 m	20'0"
Blade Base	2.60 m	8'6"	2.60 m	8'6"
Overall Width (at top of front tires)	2.46 m	8'1"	2.46 m	8'1"
Standard Blade: Length	3.66 m	12'0"	3.66 m	12'0"
Height	610 mm	2'0"	610 mm	2'0"
Thickness	22 mm	0.87"	22 mm	0.87"
Lift Above Ground	410 mm	16"	480 mm	19"
Max. Shoulder Reach:◀				
Frame Straight — right	1.93 m	6'4"	1.81 m	5'11"
Frame Straight — left	1.76 m	5'9"	1.86 m	6'1"
Fuel Tank Capacity	305 L	80.6 U.S. gal	305 L	80.6 U.S. gal

\*Typical Operating Weight — based on standard machine configuration, with Cab High Profile ROPS, 13.00-24 12 PR (G-2) tires, full fuel tank, coolant, lubricants and operator.

\*\*Minimum Turning Radius — combining the use of articulated frame steering, front wheel steer and unlocked differential.

\*\*\*Height (No Cab/Canopy) — without ROPS, exhaust, or other easily removed encumbrances.

◀ Applicable for the standard blade with hydraulic sideshift and tip control. Maximum shoulder reach is obtainable to the right.

▲ Engine Power Management automatically reduces power in gears 1F-3F and 1R-2R.



MODEL	140K		160K	
Net Flywheel Power: Gears 4-8	142 kW	190 hp	154 kW	206 hp
Gear 3▲	135 kW	181 hp	147 kW	196 hp
Gears 1-2▲	127 kW	170 hp	139 kW	186 hp
Operating Weight (Typical)*	14 768 kg	32,558 lb	15 785 kg	34,800 lb
Engine Model	C7 ACERT VHP		C7 ACERT VHP	
Rated Engine RPM	2000		2000	
No. of Cylinders	6		6	
Displacement	7.2 L	439 in <sup>3</sup>	7.2 L	439 in <sup>3</sup>
Max. Torque	46%		46%	
No. of Speeds Forward/Reverse	8/6		8/6	
Top Speed: Forward	46.8 km/h	29.1 mph	46.4 km/h	28.8 mph
Reverse	37 km/h	23 mph	36.6 km/h	22.8 mph
Std. Tires — Front and Rear	14.00-24 (12 PR) (G-2)		14.00-24 (12 PR) (G-2)	
Front Axle/Steering:				
Oscillation Angle	32°		32°	
Wheel Lean Angle	18°		18°	
Steering Angle	47.5°		47.5°	
Articulation Angle	20°		20°	
Minimum Turning Radius**	7.5 m	24'7"	7.5 m	24'7"
Front Frame Section Modulus:				
Min.	2083 cm <sup>2</sup>	127 in <sup>2</sup>	2083 cm <sup>2</sup>	127 in <sup>2</sup>
Max.	4785 cm <sup>2</sup>	291 in <sup>2</sup>	4785 cm <sup>2</sup>	291 in <sup>2</sup>
No. Circle Support Shoes	6		6	
Hydraulics: Pump Type	Variable Piston		Variable Piston	
Max. Pump Flow	205.8 L/min	54.4 gpm	205.8 L/min	54.4 gpm
Reservoir Tank Capacity	55 L	14.5 U.S. gal	55 L	14.5 U.S. gal
Implement Pressure: Max.	25 500 kPa	3699 psi	25 500 kPa	3699 psi
Min.	3600 kPa	522 psi	3600 kPa	522 psi
Electrical:				
System Size	24V		24V	
Std. Battery CCA @ 0° F	750		750	
Std. Alternator	95 amp		95 amp	
GENERAL DIMENSIONS:				
Height (to top of ROPS)	3.35 m	11'0"	3.35 m	11'0"
Height (No Cab/Canopy)***	3.05 m	10'0"	3.05 m	10'0"
Overall Length	8.50 m	27'11"	8.50 m	27'11"
With Ripper and Pushplate	10.01 m	32'10"	10.01 m	32'10"
Wheelbase	6.09 m	20'0"	6.09 m	20'0"
Blade Base	2.60 m	8'6"	2.55 m	8'4"
Overall Width (at top of front tires)	2.48 m	8'2"	2.48 m	8'2"
Standard Blade: Length	3.66 m	12'0"	4.27 m	14'0"
Height	610 mm	2'0"	686 mm	2'3"
Thickness	22 mm	0.87"	25 mm	1"
Lift Above Ground	480 mm	18.9"	452 mm	17.8"
Max. Shoulder Reach:◀				
Frame Straight — right	1.98 m	6'6"	2.26 m	7'5"
Frame Straight — left	1.90 m	6'3"	2.22 m	7'4"
Fuel Tank Capacity	305 L	80.6 U.S. gal	344 L	90.9 U.S. gal

\*Typical Operating Weight — based on standard machine configuration, with Cab High Profile ROPS, 14.00-24 12 PR (G-2) tires, full fuel tank, coolant, lubricants and operator.

\*\*Minimum Turning Radius — combining the use of articulated frame steering, front wheel steer and unlocked differential.

\*\*\*Height (No Cab/Canopy) — without ROPS, exhaust, or other easily removed encumbrances.

◀ Applicable for the standard blade with hydraulic sideshift and tip control. Maximum shoulder reach is obtainable to the right.

▲ Engine Power Management automatically reduces power in gears 1F-3F and 1R-2R.



MODEL	120M		12M	
Base Power — Net	103 kW	138 hp	118 kW	158 hp
VHP Range — Net	103-114 kW	138-153 hp	118-129 kW	158-173 hp
VHP Plus Range — Net	103-129 kW	138-173 hp	118-144 kW	158-193 hp
Operating Weight*	14 466 kg	31,891 lb	14 998 kg	33,064 lb
Engine Model	<b>C6.6 ACERT VHP</b>		<b>C6.6 ACERT VHP</b>	
Rated Engine RPM	2000		2000	
No. of Cylinders	6		6	
Displacement	6.6 L	403 in <sup>3</sup>	6.6 L	403 in <sup>3</sup>
Max. Torque	859 N·m	690 lb·ft	859 N·m	690 lb·ft
No. of Speeds Forward/Reverse	8/6		8/6	
Top Speed: Forward	44.5 km/h	27.7 mph	44.5 km/h	27.7 mph
Reverse	37.8 km/h	23.5 mph	37.8 km/h	23.5 mph
Std. Tires — Front and Rear	13.00 24 (12 PR) (G-2)		13.00 24 (12 PR) (G-2)	
Front Axle/Steering:				
Oscillation Angle	32°		32°	
Wheel Lean Angle	18.0°		18.0°	
Steering Angle	47.5°		47.5°	
Articulation Angle	20°		20°	
Minimum Turning Radius**	7.5 m	24'6"	7.5 m	24'6"
No. Circle Support Shoes	4		6	
Hydraulics:				
Pump Type	<b>Variable Piston</b>		<b>Variable Piston</b>	
Max. Pump Flow	151 L/min	40 gpm	193 L/min	51 gpm
Tank Capacity	60 L	15.9 U.S. gal	60 L	15.9 U.S. gal
Implement Pressure: Max.	24 150 kPa	3500 psi	24 150 kPa	3500 psi
Min.	3100 kPa	450 psi	3100 kPa	450 psi
Interior Sound Level/SAE J919	70 dB(A)		70 dB(A)	
Electrical:				
System Size	24V		24V	
Std. Battery CCA @ 0° F	880		880	
Std. Alternator	80		80	
GENERAL DIMENSIONS:				
Height (to top of ROPS)	3278 mm	129"	3278 mm	129"
Overall Length	8488 mm	334"	8488 mm	334"
With Ripper and Pushplate	9889 mm	389"	9889 mm	389"
Wheelbase	5915 mm	233"	5915 mm	233"
Blade Base	2511 mm	99"	2511 mm	99"
Overall Width (at top of front tires)	2481 mm	98"	2481 mm	98"
Standard Blade: Length	3658 mm	12'0"	3658 mm	12'0"
Height	610 mm	24"	610 mm	24"
Thickness	22 mm	0.87"	22 mm	0.87"
Lift Above Ground	427 mm	16.8"	427 mm	16.8"
Max. Shoulder Reach:***				
Frame Straight — left	1742 mm	68.6"	1742 mm	68.6"
Frame Straight — right	1905 mm	75"	1905 mm	75"
Fuel Tank Capacity	340 L	90 U.S. gal	340 L	90 U.S. gal

\*Operating Weight — based on standard machine configuration with full fuel tank, coolant, lubricants and operator.

\*\*Minimum Turning Radius — combining the use of articulated frame steering, front wheel steer and unlocked differential.

\*\*\*Applicable for the standard blade with hydraulic sideshift and tip control. Maximum shoulder reach is obtainable to the right.



140M



160M

MODEL	140M		160M	
Base Power — Net	136 kW	183 hp	159 kW	213 hp
VHP Range — Net	136-155 kW	183-208 hp	159-170 kW	213-228 hp
VHP Plus Range — Net	136-174 kW	183-233 hp	159-185 kW	213-248 hp
Operating Weight*	16 197 kg	35,708 lb	16 506 kg	36,390 lb
Engine Model	<b>C7 ACERT VHP/C9 ACERT VHP (AWD)</b>		<b>C9 ACERT VHP</b>	
Rated Engine RPM	2000		2000	
No. of Cylinders	6		6	
Displacement	7.2 L/8.8 L	439 in <sup>3</sup> /537 in <sup>3</sup>	8.8 L	537 in <sup>3</sup>
Max. Torque	1079 N·m/1237 N·m	796 lb-ft/912 lb-ft	1237 N·m	912 lb-ft
No. of Speeds Forward/Reverse	8/6		8/6	
Top Speed: Forward	46.6 km/h	29 mph	47.4 km/h	29.5 mph
Reverse	36.8 km/h	22.9 mph	37.4 km/h	23.3 mph
Std. Tires — Front and Rear	14.00 24 (10 PR) (G-2)		14.00 24 (10 PR) (G-2)	
Front Axle/Steering:				
Oscillation Angle	32°		32°	
Wheel Lean Angle	18.0°		18.0°	
Steering Angle	47.5°		47.5°	
Articulation Angle	20°		20°	
Minimum Turning Radius**	7.75 m	25'6"	7.75 m	25'6"
No. Circle Support Shoes	6		6	
Hydraulics:				
Pump Type	Variable Piston		Variable Piston	
Max. Pump Flow	210 L/min	55.7 gpm	210 L/min	55.7 gpm
Tank Capacity	60 L	15.9 U.S. gal	60 L	15.9 U.S. gal
Implement Pressure: Max.	24 150 kPa	3500 psi	24 150 kPa	3500 psi
Min.	3100 kPa	450 psi	3100 kPa	450 psi
Interior Sound Level/SAE J919	70 dB(A)		70 dB(A)	
Electrical:				
System Size	24V		24V	
Std. Battery CCA @ 0° F	880		880	
Std. Alternator	80		80	
GENERAL DIMENSIONS:				
Height (to top of ROPS)	3293 mm	130"	3293 mm	130"
Overall Length	8713 mm	343"	8713 mm	343"
With Ripper and Pushplate	10 144 mm	399"	10 144 mm	399"
Wheelbase	6121 mm	241"	6121 mm	241"
Blade Base	2552 mm	101"	2552 mm	101"
Overall Width (at top of front tires)	2493 mm	98"	2493 mm	98"
Standard Blade: Length	3658 mm	12'0"	3658 mm	12'0"
Height	610 mm	24"	610 mm	24"
Thickness	22 mm	0.87"	22 mm	0.87"
Lift Above Ground	480 mm	18.9"	452 mm	17.8"
Max. Shoulder Reach:***				
Frame Straight — left	1790 mm	70.5"	2090 mm	82.3"
Frame Straight — right	1978 mm	77.9"	2278 mm	89.7"
Fuel Tank Capacity	416 L	110 U.S. gal	416 L	110 U.S. gal

\*Operating Weight — based on standard machine configuration with full fuel tank, coolant, lubricants and operator.

\*\*Minimum Turning Radius — combining the use of articulated frame steering, front wheel steer and unlocked differential.

\*\*\*Applicable for the standard blade with hydraulic sideshift and tip control. Maximum shoulder reach is obtainable to the right.



<b>MODEL</b>	<b>140M2</b>		<b>160M2</b>	
Base Power — Net	144 kW	193 hp	159 kW	213 hp
VHP Range — Net	144-166 kW	193-223 hp	159-181 kW	213-243 hp
VHP Plus Range — Net	144-181 kW	193-243 hp	159-196 kW	213-263 hp
Operating Weight*	17 196 kg	37,911 lb	17 296 kg	38,131 lb
Engine Model	<b>C9.3 ACERT VHP</b>		<b>C9.3 ACERT VHP</b>	
Rated Engine RPM	2100		2100	
No. of Cylinders	6		6	
Displacement	9.3 L	567 in <sup>3</sup>	9.3 L	567 in <sup>3</sup>
Max. Torque	1247 N·m	920 lb·ft	1354 N·m	1000 lb·ft
No. of Speeds Forward/Reverse	8/6		8/6	
Top Speed: Forward	46.6 km/h	29 mph	47.4 km/h	29.5 mph
Reverse	36.8 km/h	22.9 mph	37.4 km/h	23.3 mph
Std. Tires — Front and Rear	14.00 24 (10 PR) (G-2)		14.00 24 (10 PR) (G-2)	
Front Axle/Steering:				
Oscillation Angle	32°		32°	
Wheel Lean Angle	18.0°		18.0°	
Steering Angle	47.5°		47.5°	
Articulation Angle	20°		20°	
Minimum Turning Radius**	7.75 m	25'6"	7.75 m	25'6"
No. Circle Support Shoes	6		6	
Hydraulics:				
Pump Type	<b>Variable Piston</b>		<b>Variable Piston</b>	
Max. Pump Flow	210 L/min	55.7 gpm	210 L/min	55.7 gpm
Tank Capacity	60 L	15.9 U.S. gal	60 L	15.9 U.S. gal
Implement Pressure: Max.	24 150 kPa	3500 psi	24 150 kPa	3500 psi
Min.	3100 kPa	450 psi	3100 kPa	450 psi
Interior Sound Level/SAE J919	70 dB(A)		70 dB(A)	
Electrical:				
System Size	24V		24V	
Std. Battery CCA @ 0° F	1125		1125	
Std. Alternator	150		150	
GENERAL DIMENSIONS:				
Height (to top of ROPS)	3287 mm	130"	3287 mm	130"
Overall Length	8898 mm	350"	8898 mm	350"
With Ripper and Pushplate	10 140 mm	400"	10 140 mm	400"
Wheelbase	6126 mm	241"	6126 mm	241"
Blade Base	2557 mm	101"	2557 mm	101"
Overall Width (at top of front tires)	2493 mm	98"	2493 mm	98"
Standard Blade: Length	3658 mm	12'0"	3658 mm	12'0"
Height	610 mm	24"	610 mm	24"
Thickness	22 mm	0.87"	22 mm	0.87"
Lift Above Ground	480 mm	18.9"	452 mm	17.8"
Max. Shoulder Reach:***				
Frame Straight — left	1790 mm	70.5"	2090 mm	82.3"
Frame Straight — right	1978 mm	77.9"	2278 mm	89.7"
Fuel Tank Capacity	416 L	110 U.S. gal	416 L	110 U.S. gal

\*Operating Weight — based on standard machine configuration with full fuel tank, coolant, lubricants and operator.

\*\*Minimum Turning Radius — combining the use of articulated frame steering, front wheel steer and unlocked differential.

\*\*\*Applicable for the standard blade with hydraulic sideshift and tip control. Maximum shoulder reach is obtainable to the right.



MODEL	14M		16M		24M	
Base Power — Net	193 kW	259 hp	221 kW	297 hp	397 kW	533 hp
VHP Range — Net	193-204 kW	259-274 hp	221-233 kW	297-312 hp	—	—
VHP Plus Range — Net	193-219 kW	259-294 hp	221-248 kW	297-332 hp	—	—
Operating Weight*	21 226 kg	46,796 lb	26 959 kg	59,435 lb	62 457 kg	137,694 lb
Engine Model	C11		C13 ACERT VHP		C18 ACERT	
Rated Engine RPM	1800		2000		1800	
No. of Cylinders	6		6		6	
Displacement	11.1 L	677 in <sup>3</sup>	12.5 L	763 in <sup>3</sup>	18.1 L	1104.5 in <sup>3</sup>
Max. Torque	1422 N·m	1049 lb·ft	1710 N·m	1261 lb·ft	2389 N·m	1762 lb·ft
No. of Speeds Forward/Reverse	8/6		8/6		6/3	
Top Speed: Forward	49.8 km/h	31 mph	53.9 km/h	33.5 mph	43 km/h	26.7 mph
Reverse	39.4 km/h	24.5 mph	42.6 km/h	26.5 mph	41.2 km/h	25.6 mph
Std. Tires — Front and Rear	16.00-24 (16 PR) (G-2)		18.00-25 (12 PR) (G-2)		—	
Front Axle/Steering:						
Oscillation Angle	32°		32°		32°	
Wheel Lean Angle	17.1°		18.2°		18.0°	
Steering Angle	47.5°		47.5°		47.5°	
Articulation Angle	20°		20°		25°	
Minimum Turning Radius**	7.9 m	25'11"	8.9 m	29'3"	12.4 m	40'9"
No. Circle Support Shoes	6		6		6	
Hydraulics:						
Pump Type	Variable Piston		Variable Piston		Variable Piston	
Max. Pump Flow	280 L/min	74 gpm	280 L/min	74 gpm	550 L/min	145 gpm
Tank Capacity	60 L	15.9 U.S. gal	65 L	17.2 U.S. gal	264 L	70 U.S. gal
Implement Pressure: Max.	24 150 kPa	3500 psi	24 150 kPa	3500 psi	24 150 kPa	3500 psi
Min.	3100 kPa	450 psi	3100 kPa	450 psi	3100 kPa	450 psi
Interior Sound Level/SAE J919	70 dB(A)		72 dB(A)		74 dB(A)	
Electrical:						
System Size	24V		24V		24V	
Std. Battery CCA @ 0° F	1125		1400		1500	
Std. Alternator	80		150		150	
GENERAL DIMENSIONS:						
Height (to top of ROPS)	3535 mm	139.2"	3703 mm	145.8"	4452 mm	175.3"
Overall Length	9412 mm	370.6"	9963 mm	392.2"	14 194 mm	558.8"
With Ripper and Pushplate	10 896 mm	429"	11 672 mm	459.5"	16 102 mm	633.9"
Wheelbase	6559 mm	258"	6985 mm	275"	10 278 mm	404.6"
Blade Base	2842 mm	112"	3069 mm	120.8"	4048 mm	159.4"
Overall Width (at top of front tires)	2791 mm	109.9"	3096 mm	121.9"	4280 mm	168.5"
Standard Blade: Length	4287 mm	14'0"	4877 mm	16'0"	7315 mm	24'0"
Height	686 mm	27"	787 mm	31"	1076 mm	42"
Thickness	25 mm	1"	25 mm	1"	50 mm	2"
Lift Above Ground	419 mm	16.5"	395 mm	15.6"	634 mm	25"
Max. Shoulder Reach:***						
Frame Straight — left	2169 mm	85.4"	2282 mm	90"	3222 mm	126.9"
Frame Straight — right	2279 mm	89.7"	2587 mm	101.9"	3228 mm	127.1"
Fuel Tank Capacity	492 L	130 U.S. gal	492 L	130 U.S. gal	1326 L	350 U.S. gal

\*Operating Weight — based on standard machine configuration with full fuel tank, coolant, lubricants and operator. 24M includes ripper.

\*\*Minimum Turning Radius — combining the use of articulated frame steering, front wheel steer and unlocked differential.

\*\*\*Applicable for the standard blade with hydraulic sideshift and tip control. Maximum shoulder reach is obtainable to the right.



**TRAVEL SPEEDS @ RATED RPM WITH STD. TIRES (M SERIES GLOBAL VERSION)**

Gear		1		2		3		4		5		6		7		8	
		km/h	mph	km/h	mph	km/h	mph	km/h	mph	km/h	mph	km/h	mph	km/h	mph	km/h	mph
120M	Forward	3.9	2.4	5.3	3.3	7.6	4.75	10.5	6.5	16.4	10.2	22.2	13.8	30.6	19.0	44.5	27.7
	Reverse	3.3	2.0	6.2	3.8	8.9	5.6	13.9	8.6	26.0	16.1	37.8	23.5	—	—	—	—
12M	Forward	3.9	2.4	5.3	3.3	7.6	4.75	10.5	6.5	16.4	10.2	22.2	13.8	30.6	19.0	44.5	27.7
	Reverse	3.3	2.0	6.2	3.8	8.9	5.6	13.9	8.6	26.0	16.1	37.8	23.5	—	—	—	—
140M	Forward	4.0	2.5	5.5	3.4	8.0	5.0	11.0	6.8	17.1	10.6	23.3	14.5	32.0	19.9	46.6	29.0
	Reverse	3.2	2.0	6.0	3.7	8.7	5.4	13.5	8.4	25.3	15.7	36.8	22.9	—	—	—	—
140M2	Forward	4.05	2.52	5.50	3.42	7.99	4.97	11.02	6.85	17.10	10.63	23.27	14.46	32.04	19.91	46.60	28.96
	Reverse	3.19	1.98	5.98	3.72	8.70	5.41	13.51	8.40	25.29	15.70	36.80	22.87	—	—	—	—
160M	Forward	4.1	2.5	5.6	3.5	8.1	5.0	11.2	7.0	17.4	10.8	23.7	14.7	32.6	20.3	47.4	29.5
	Reverse	3.3	2.0	6.1	3.8	8.8	5.5	13.7	8.5	25.7	16.0	37.4	23.3	—	—	—	—
160M2	Forward	4.05	2.52	5.50	3.42	7.99	4.97	11.02	6.85	17.10	10.63	23.27	14.46	32.04	19.91	46.60	28.96
	Reverse	3.19	1.98	5.98	3.72	8.70	5.41	13.51	8.40	25.29	15.70	36.80	22.87	—	—	—	—
14M	Forward	4.3	2.7	5.9	3.7	8.6	5.3	11.8	7.3	18.3	11.4	24.8	15.4	34.2	21.3	49.8	31.0
	Reverse	3.4	2.1	6.4	4.0	9.3	5.8	14.5	9.0	27.1	16.9	39.4	24.5	—	—	—	—
16M	Forward	4.5	2.8	6.3	3.9	9.0	5.6	12.4	7.7	19.3	12.0	26.8	16.7	37.0	23.0	53.9	33.5
	Reverse	3.6	2.2	6.8	4.2	9.8	6.1	15.2	9.5	29.3	18.2	42.6	26.5	—	—	—	—
24M	Forward	3.6	2.3	5.7	3.5	9.6	6.0	15.0	9.3	27.7	17.2	43.0	26.7	—	—	—	—
	Reverse	5.4	3.4	14.3	8.9	41.2	25.6	—	—	—	—	—	—	—	—	—	—

**TRAVEL SPEEDS @ RATED RPM WITH STD. TIRES (K SERIES STANDARD VERSION)**

Gear		1		2		3		4		5		6		7		8	
		km/h	mph	km/h	mph	km/h	mph	km/h	mph	km/h	mph	km/h	mph	km/h	mph	km/h	mph
120K	Forward	3.9	2.4	5.3	3.3	7.7	4.8	10.7	6.6	16.8	10.4	22.8	14.2	31.4	19.5	45.7	28.4
	Reverse	3.1	1.9	5.8	3.6	8.4	5.2	13.3	8.2	24.8	15.4	36.1	22.4	—	—	—	—
12K	Forward	3.8	2.4	5.2	3.2	7.6	4.7	10.4	6.5	16.5	10.2	22.4	13.9	30.8	19.2	44.8	27.9
	Reverse	3.0	1.9	5.7	3.5	8.2	5.1	13.0	8.1	24.3	15.1	35.4	22.0	—	—	—	—
140K	Forward	4.0	2.5	5.4	3.4	7.9	4.9	10.9	6.8	17.2	10.7	23.4	14.5	32.2	20.0	46.8	29.1
	Reverse	3.2	2.0	5.9	3.7	8.6	5.3	13.6	8.4	25.4	15.8	37.0	23.0	—	—	—	—
160K	Forward	4.1	2.5	5.5	3.4	8.0	4.9	11.0	6.8	17.0	10.6	23.2	14.4	31.9	19.8	46.4	28.8
	Reverse	3.2	2.0	5.9	3.7	8.7	5.4	13.4	8.4	25.2	15.6	36.6	22.8	—	—	—	—

- All Wheel Drive
- Mid Mount and Front Mount Scarifiers

**ALL WHEEL DRIVE (AWD)**

**120M, 140M/M2, 160M/M2**

Working Range:	
Forward Gears	<b>gears 1-7</b>
Reverse Gears	<b>gears 1-5</b>
Pump Type	<b>Variable Displacement Axial Piston Pumps (2)</b>
Motor Type	<b>Variable Displacement Axial Piston Motors (2)</b>
Front Wheel Gear Reduction	<b>Double Planetary Reduction</b>
Maximum Pump Flow (each pump)	125 L/min <b>33 gpm</b>
Front Wheel Torque	13 998 N·m <b>10,325 lb-ft</b>
Control Type	<b>Speed control with closed-loop feedback</b>

The optional AWD system utilizes dedicated left and right pumps for precise hydraulic control.

Gross power is automatically increased up to 26 kW (**35 hp**) with AWD engaged, maintaining a constant net power to the ground.

Hydrostatic Mode disengages the transmission and provides hydraulic power to the front wheels only-ininitely variable to 8 km/h (**5 mph**).

Exclusive AWD Steering Compensation adjusts outside front tire speed up to 50% faster than the inside tire.

Operating Pressure depends on engine speed, gear selection and operating conditions.

**M10 — MID MOUNT SCARIFIER**

**120M, 12M, 140M/M2, 160M/M2**

Type	V-type		Straight type*	
Working Width	1184 mm	<b>46.6"</b>	1800 mm	<b>71"</b>
Depth (Max.)	292 mm	<b>11.5"</b>	317 mm	<b>12.5"</b>
Number of Shank Holders		<b>11</b>		<b>17</b>
Spacing	116 mm	<b>4.6"</b>	111 mm	<b>4.4"</b>

\*Available on M Series Global Versions only.

**FRONT MOUNT SCARIFIER**

**120M, 12M, 140M/M2, 160M/M2**

Type	V-type	
Working Width	1205 mm	<b>47.4"</b>
Depth (Max.)	467 mm	<b>18.4"</b>
Number of Shank Holders		<b>11</b>
Spacing	116 mm	<b>4.6"</b>

<b>MOTOR GRADER/ RIPPER</b>	<b>120M</b>		<b>120M</b>		<b>12M</b>		<b>140M</b>		<b>140M2</b>	
<b>Parallelogram — Rear Mounted</b>	<b>Lightweight Ripper</b>		<b>Ripper/ Scarifier</b>		<b>Ripper/ Scarifier</b>		<b>Ripper/ Scarifier</b>		<b>Ripper/ Scarifier</b>	
<b>Tire Size (Std.) Front and Rear</b>	<b>13.00 24 12PR (G-4)</b>		<b>13.00 24 12PR (G-4)</b>		<b>13.00-24 12PR (G-2)</b>		<b>14.00-24 10PR (G-2)</b>		<b>14.00-24 10PR (G-2)</b>	
<b>Scarifier</b>										
Maximum Digging Depth	—		267 mm	<b>10.5"</b>	267 mm	<b>10.5"</b>	267 mm	<b>10.5"</b>	267 mm	<b>10.5"</b>
Number of Pockets	—		<b>9</b>		<b>9</b>		<b>9</b>		<b>9</b>	
Spacing	—		267 mm	<b>10.5"</b>	267 mm	<b>10.5"</b>	267 mm	<b>10.5"</b>	267 mm	<b>10.5"</b>
<b>Ripper Shank</b>										
Maximum Digging Depth	225 mm	<b>8.9"</b>	428 mm	<b>16.9"</b>	428 mm	<b>16.9"</b>	422 mm	<b>16.6"</b>	422 mm	<b>16.6"</b>
Maximum Reach at Ground Line	1034 mm	<b>3'4.7"</b>	973 mm	<b>38.3"</b>	973 mm	<b>38.3"</b>	973 mm	<b>38.3"</b>	973 mm	<b>38.3"</b>
Maximum Ground Clearance under Tip (shank pinned in bottom hole)	642 mm	<b>25.3"</b>	502 mm	<b>19.8"</b>	502 mm	<b>19.8"</b>	508 mm	<b>20"</b>	508 mm	<b>20"</b>
Maximum Ramp Angle, Ripper Up (shank pinned in bottom hole)	<b>23°</b>		<b>15°</b>		<b>15°</b>		<b>15°</b>		<b>15°</b>	
Shank Section	36 × 76 mm <b>1.4" × 3"</b>		59 × 138 mm <b>2.3" × 5.4"</b>		59 × 138 mm <b>2.3" × 5.4"</b>		59 × 138 mm <b>2.3" × 5.4"</b>		59 × 138 mm <b>2.3" × 5.4"</b>	
<b>Ripper Beam</b>										
Overall Width	2.30 m	<b>7'7"</b>	2.31 m	<b>7'7"</b>	2.31 m	<b>7'7"</b>	2.31 m	<b>7'7"</b>	2.31 m	<b>7'7"</b>
Height	152 mm	<b>6.0"</b>	152 mm	<b>6.0"</b>	152 mm	<b>6.0"</b>	152 mm	<b>6.0"</b>	152 mm	<b>6.0"</b>
Length	182 mm	<b>7.2"</b>	230 mm	<b>9.1"</b>	230 mm	<b>9.1"</b>	230 mm	<b>9.1"</b>	230 mm	<b>9.1"</b>
Number of Pockets	<b>5</b>		<b>5</b>		<b>5</b>		<b>5</b>		<b>5</b>	
Pocket Spacing:										
Inside	533 mm	<b>1'9"</b>	533 mm	<b>1'9"</b>	533 mm	<b>1'9"</b>	533 mm	<b>1'9"</b>	533 mm	<b>1'9"</b>
Middle	533 mm	<b>1'9"</b>	533 mm	<b>1'9"</b>	533 mm	<b>1'9"</b>	533 mm	<b>1'9"</b>	533 mm	<b>1'9"</b>
Outside	533 mm	<b>1'9"</b>	533 mm	<b>1'9"</b>	533 mm	<b>1'9"</b>	533 mm	<b>1'9"</b>	533 mm	<b>1'9"</b>
Shank Gauge	2.13 m	<b>7'0"</b>	2.13 m	<b>7'0"</b>	2.13 m	<b>7'0"</b>	2.13 m	<b>7'0"</b>	2.13 m	<b>7'0"</b>
Installed Weights:										
Ripper with Standard Shank	613 kg	<b>1350 lb</b>	1100 kg	<b>2425 lb</b>	1100 kg	<b>2425 lb</b>	1111 kg	<b>2449 lb</b>	1111 kg	<b>2449 lb</b>
Each Additional Shank	11 kg	<b>24 lb</b>	31 kg	<b>68 lb</b>	31 kg	<b>68 lb</b>	31 kg	<b>68 lb</b>	31 kg	<b>68 lb</b>
Ripper Forces:										
Penetration Force	4343 kg	<b>9566 lb</b>	8031 kg	<b>17,705 lb</b>	8578 kg	<b>18,911 lb</b>	9156 kg	<b>20,186 lb</b>	9440 kg	<b>20,768 lb</b>
Pryout Force	2279 kg	<b>5020 lb</b>	11 911 kg	<b>26,259 lb</b>	11 781 kg	<b>25,973 lb</b>	11 911 kg	<b>26,259 lb</b>	12 552 kg	<b>27,614 lb</b>

<b>MOTOR GRADER/ RIPPER</b>	<b>160M</b>		<b>160M2</b>		<b>14M</b>		<b>16M</b>		<b>24M</b>	
<b>Parallelogram — Rear Mounted</b>	<b>Ripper/Scarifier</b>		<b>Ripper/Scarifier</b>		<b>Ripper</b>		<b>Ripper</b>		<b>Ripper</b>	
<b>Tire Size (Std.) Front and Rear</b>	<b>14.00-24 10PR (G-2)</b>		<b>14.00-24 10PR (G-2)</b>		<b>16.00-24 16PR (G-2)</b>		<b>18.00-25 12PR (G-2)</b>		<b>29.5-29 28PR</b>	
<b>Scarifier</b>										
Maximum Digging Depth	267 mm	<b>10.5"</b>	267 mm	<b>10.5"</b>	—	—	—	—	—	—
Number of Pockets	<b>9</b>		<b>9</b>		—	—	—	—	—	—
Spacing	267 mm	<b>10.5"</b>	267 mm	<b>10.5"</b>	—	—	—	—	—	—
<b>Ripper Shank</b>										
Maximum Digging Depth	422 mm	<b>16.6"</b>	422 mm	<b>16.6"</b>	402 mm	<b>15.8"</b>	452 mm	<b>17.8"</b>	490 mm	<b>1'7.3"</b>
Maximum Reach at Ground Line	973 mm	<b>38.3"</b>	973 mm	<b>38.3"</b>	1061 mm	<b>41.8"</b>	1500 mm	<b>4'11"</b>	1165 mm	<b>3'9.9"</b>
Maximum Ground Clearance under Tip (shank pinned in bottom hole)	508 mm	<b>20"</b>	508 mm	<b>20"</b>	635 mm	<b>25"</b>	673 mm	<b>2'2.5"</b>	739 mm	<b>2'5.1"</b>
Maximum Ramp Angle, Ripper Up (shank pinned in bottom hole)	<b>15°</b>		<b>15°</b>		<b>15°</b>		<b>21°</b>		<b>20°</b>	
Shank Section	59 × 138 mm <b>2.3" × 5.4"</b>		59 × 138 mm <b>2.3" × 5.4"</b>		59 × 138 mm <b>2.3" × 5.4"</b>		76 × 178 mm <b>3" × 7"</b>		76 × 178 mm <b>3" × 7"</b>	
<b>Ripper Beam</b>										
Overall Width	2.31 m	<b>7'7"</b>	2.31 m	<b>7'7"</b>	2.60 m	<b>8'6"</b>	2.98 m	<b>9'9"</b>	3.91 m	<b>12'10"</b>
Height	152 mm	<b>6.0"</b>	152 mm	<b>6.0"</b>	165 mm	<b>6.5"</b>	214 mm	<b>8.4"</b>	216 mm	<b>8.5"</b>
Length	230 mm	<b>9.1"</b>	230 mm	<b>9.1"</b>	211 mm	<b>8.3"</b>	254 mm	<b>10"</b>	254 mm	<b>10"</b>
Number of Pockets	<b>5</b>		<b>5</b>		<b>7</b>		<b>7</b>		<b>7</b>	
Pocket Spacing:										
Inside	533 mm	<b>1'9"</b>	533 mm	<b>1'9"</b>	472 mm	<b>1'7"</b>	500 mm	<b>1'8"</b>	593 mm	<b>1'11.4"</b>
Middle	533 mm	<b>1'9"</b>	533 mm	<b>1'9"</b>	373 mm	<b>1'3"</b>	445 mm	<b>17.5"</b>	604 mm	<b>1'11.8"</b>
Outside	533 mm	<b>1'9"</b>	533 mm	<b>1'9"</b>	373 mm	<b>1'3"</b>	445 mm	<b>17.5"</b>	604 mm	<b>1'11.8"</b>
Shank Gauge	2.13 m	<b>7'0"</b>	2.13 m	<b>7'0"</b>	2.44 m	<b>8'0"</b>	—	—	—	—
Installed Weights:										
Ripper with Standard Shank	1111 kg	<b>2449 lb</b>	1111 kg	<b>2449 lb</b>	1488 kg	<b>3280 lb</b>	2177 kg	<b>4799 lb</b>	2812 kg	<b>6186 lb</b>
Each Additional Shank	31 kg	<b>68 lb</b>	31 kg	<b>68 lb</b>	31 kg	<b>68 lb</b>	68 kg	<b>150 lb</b>	68 kg	<b>150 lb</b>
Ripper Forces:										
Penetration Force	9317 kg	<b>20,540 lb</b>	9440 kg	<b>20,768 lb</b>	12 348 kg	<b>27,223 lb</b>	10 163 kg	<b>22,410 lb</b>	11 851 kg	<b>26,138 lb</b>
Pryout Force	11 911 kg	<b>26,259 lb</b>	13 322 kg	<b>29,370 lb</b>	12 767 kg	<b>28,146 lb</b>	15 323 kg	<b>33,788 lb</b>	17 386 kg	<b>38,330 lb</b>

**PRODUCTION**

The motor grader is used in a variety of applications in a variety of industries. Therefore, there are many ways to measure its operating capacity, or production. One method expresses a motor grader’s production in relation to the area covered by the moldboard.

**Formula:**

$$A = S \times (L_e - L_o) \times 1000 \times E \text{ (Metric)}$$

$$A = S \times (L_e - L_o) \times 5280 \times E \text{ (English)}$$

- where A: Hourly operating area (m<sup>2</sup>/h or ft<sup>2</sup>/h)  
 S: Operating speed (km/h or mph)  
 L<sub>e</sub>: Effective blade length (m or ft)  
 L<sub>o</sub>: Width of overlap (m or ft)  
 E: Job efficiency

**Operating Speeds:**

Typical operating speeds by application

Finish Grading:	0-4 km/h	(0-2.5 mph)
Heavy Blading:	0-9 km/h	(0-6 mph)
Ditch Repair:	0-5 km/h	(0-3 mph)
Ripping:	0-5 km/h	(0-3 mph)
Road Maintenance:	5-16 km/h	(3-9.5 mph)
Haul Road Maintenance:	5-16 km/h	(3-9.5 mph)
Snow Plowing:	7-21 km/h	(4-13 mph)
Snow Winging:	15-28 km/h	(9-17 mph)

**Effective Blade Length:**

Since the moldboard is usually angled when moving material, an effective blade length must be computed to account for this angle. This is the actual width of material swept by the moldboard.

**NOTE:** Angles are measured as shown below. The effective length becomes shorter as the angle increases.

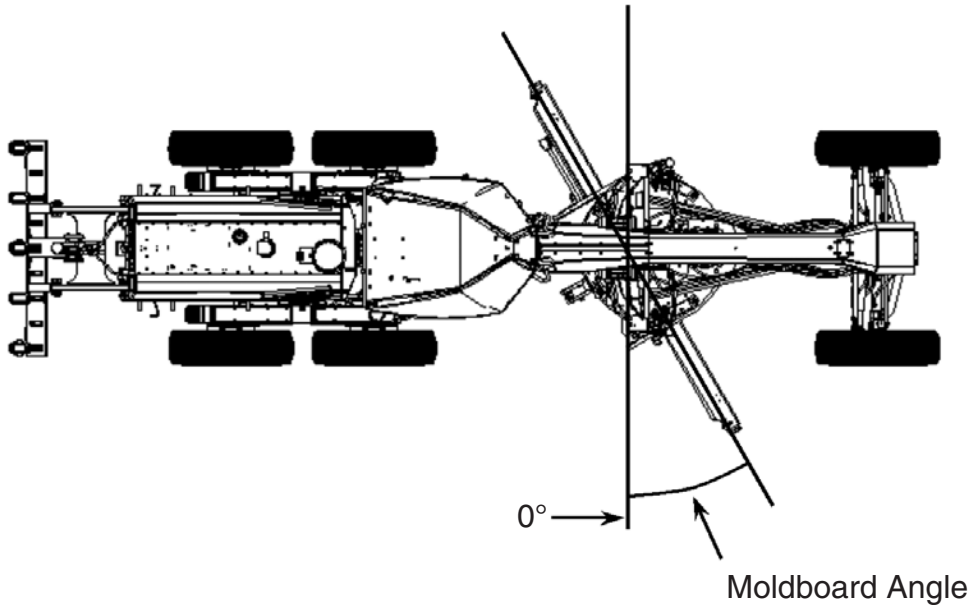

Moldboard Length, m (ft)	Effective Length, m (ft) 30 degree blade angle	Effective Length, m (ft) 45 degree blade angle
3.658 (12)	3.17 (10.4)	2.59 (8.5)
3.962 (13)	3.43 (11.3)	2.80 (9.2)
4.267 (14)	3.70 (12.1)	3.02 (9.9)
4.877 (16)	4.22 (13.9)	3.45 (11.3)
7.315 (24)	6.33 (20.8)	5.17 (17.0)

For other blade lengths and carry angles:

$$\text{Effective length} = \text{COS} [\text{Radians (Blade L)}] \times \text{Blade Length}$$

### Width of Overlap:

The width of overlap is generally 0.6 m (2.0 ft). This overlap accounts for the need to keep the tires out of the windrow on the return pass.

### Job Efficiency:

Job efficiencies vary based on job conditions, operator skill, etc.

A good estimation for efficiency is approximately 0.70 to 0.85, but actual operating conditions should be used to determine the best value.

### Example problem:

A 140M motor grader with a 3.66 m (12 ft) moldboard is performing road maintenance on a township road. The machine is working at an average speed of 13 km/h (8 mph) with a moldboard carry angle of 30 degrees. What is the motor grader's production based on coverage area?

**Note:** Due to the long passes involved in road maintenance — fewer turnarounds — a higher job efficiency of 0.90 is chosen.

### Solution:

From the table, the effective blade length is 3.17 m (10.4 ft).

### Metric

$$\begin{aligned} \text{Production, A} &= 13 \text{ km/h} \times (3.17 \text{ m} - 0.6 \text{ m}) \times \\ &1000 \times 0.90 \\ &= \mathbf{30\,069 \text{ m}^2/\text{hr} (3.07 \text{ hectares/hr})} \end{aligned}$$

### English

$$\begin{aligned} \text{Production, A} &= 8 \text{ mph} \times (10.4 \text{ ft} - 2.0 \text{ ft}) \times \\ &5280 \times 0.90 \\ &= \mathbf{319,334 \text{ ft}^2/\text{hr} (7.33 \text{ acres/hr})} \end{aligned}$$

Figure 1

MOTOR GRADER COMPARISON in HAUL ROAD MAINTENANCE					Worksheet Variables		
Motor Grader Model	Moderate		Difficult		Application Variables		
	Cat 16M	Cat 16M	Cat 24M	Cat 24M	Pass Overlap Width (m)	Moldboard Angle	Road Width (m)
Haul Road Length Maintained (meters)	1000	1000	1000	1000	2	36	35
Haul Road Width (meters)	35	35	35	35			
Motor Grader Blade Width (meters)	4.9	4.9	7.3	7.3			
Blade Carry Angle	36	36	36	36			
1st Pass Blade Coverage (meters)	3.9	4.0	5.9	5.9			
Remaining Passes Blade Coverage (meters)	1.9	2.0	3.9	3.9			
Grader Passes Required/Road Width	17	17	8	8			
Maintenance Transmission Gear	3	3	3	3			
Maintenance Speed (km/h)	9.0	6.0	10.0	7.0			
<b>Time Analysis:</b>							
Time/Pass (minutes)	6.67	10.00	6.00	8.57			
Maneuver Time/Pass (minutes)	0.50	0.50	0.50	0.50			
Total Time/Pass (minutes)	7.17	10.50	6.50	9.07			
Total Time to Grade Haul Road (hours)	1.91	2.80	0.76	1.06			
Total Time to Grade 1 km (50-min. hour)	2.29	3.36	0.91	1.27			
<b>Road Coverage Requirements</b>							
<b>Coverage Requirement:</b>					<b>Frequency of Maintenance</b>		<b>Percentage</b>
Total km of Haul Roads	30	30	30	30	Total km of Haul Roads	30	
% Graded One Time Per 14 Shifts (1 week)	10%	10%	10%	10%	Weekly	10%	
% Graded One Time Per 4 Shifts (2 days)	30%	30%	30%	30%	Every other day	30%	
% Graded One Time Per 2 Shifts (1 day)	15%	15%	15%	15%	Daily	15%	
% Graded One Time Per Shift	25%	25%	25%	25%	Once per shift	25%	
% Graded Two Times Per Shift	20%	20%	20%	20%	Twice per shift	20%	
% Graded Three Times Per Shift	0%	0%	0%	0%	Three times per shift	0%	
Total km of Haul Roads/Shift	24.2	24.2	24.2	24.2	Total — must equal 100%	100%	
Working Hours Per Shift	11	11	11	11			
km of Road/Grader/Shift	4.79	3.27	12.08	8.66			
<b>Fleet Requirement:</b>							
“Working” Motor Graders Required/Shift	5.1 to 7.4		2.0 to 2.8				
Motor Grader Mechanical Availability	90%	90%	90%	90%			
Motor Grader Fleet Required (units)	5.6 to 8.2		2.2 to 3.1				

**NOTE:** The above numbers are generated from the formulas and inputs in Figure 2. This is the finished spreadsheet’s output when set up according to Figure 2.

- Moderate:
- Road Maintenance
  - Pad Cleaning
  - Rock Clearing
  - Shoulder Sweeping

- Difficult:
- Ripping
  - Spreading Dump Material
  - Road Profiling/Reshaping

Figure 2

MOTOR GRADER COMPARISON in HAUL ROAD MAINTENANCE		Worksheet Variables		
	Moderate	Application Variables		
	Cat 16M	Pass Overlap Width (m)	Moldboard Angle	Road Width (m)
Motor Grader Model				
Haul Road Length Maintained (meters)	1000			
Haul Road Width (meters)	= \$M\$8	2	36	35
Motor Grader Blade Width (meters)	4.88			
Blade Carry Angle	= \$L\$8			
1st Pass Blade Coverage (meters)	= COS(RADIANS(B10))*B9			
Remaining Passes Blade Coverage (meters)	= B11 - \$J\$8			
Grader Passes Required/Road Width	= ROUND((B8 - B11)/B12,0)			
Maintenance Transmission Gear	3			
Maintenance Speed (km/h)	9			
<b>Time Analysis:</b>				
Time/Pass (minutes)	= (+ B7/1000)*(60/B15)			
Maneuver Time/Pass (minutes)	0.5			
Total Time/Pass (minutes)	= SUM(B18:B19)			
Total Time to Grade Haul Road (hours)	= B13*B20/60			
Total Time to Grade 1 km (50-min. hour)	= 1000/B7*B22/0.833			
		Road Coverage Requirements		
		Frequency of Maintenance	Percentage	
<b>Coverage Requirement:</b>				
Total km of Haul Roads	= \$M\$28	Total km of Haul Roads	30	
% Graded One Time Per 14 Shifts (1 week)	= \$M\$29	Weekly	0.1	
% Graded One Time Per 4 Shifts (2 days)	= \$M\$30	Every other day	0.3	
% Graded One Time Per 2 Shifts (1 day)	= \$M\$31	Daily	0.15	
% Graded One Time Per Shift	= \$M\$32	Once per shift	0.25	
% Graded Two Times Per Shift	= \$M\$33	Twice per shift	0.2	
% Graded Three Times Per Shift	= \$M\$34	Three times per shift	0	
Total km of Haul Roads/Shift	= (B28*B29*0.0714) + (B28*B30*0.25) + (B28*B31*0.5) + (B28*B32*1) + (B28*B33*2) + (B28*B34*3)	Total — must equal 100%	= SUM(M29:M34)	
Working Hours Per Shift	11			
km of Road/Grader/Shift	= B37/B24			
<b>Fleet Requirement:</b>				
“Working” Motor Graders Required/Shift	= B35/B38			
Motor Grader Mechanical Availability	0.9			
Motor Grader Fleet Required (units)	= B41/B42			

**NOTE:** The formulas in the “Moderate — Cat 16M” column are the same formulas needed for the “Difficult — Cat 16M,” “Moderate — Cat 24M” and “Difficult — Cat 24M” columns.

Input the data from this spreadsheet exactly how you see it here. This will allow you to generate Figure 1. If you have any questions or difficulties please contact the Motor Grader Marketing Group. If you can receive e-mails, Motor Grader Marketing will e-mail you the file containing the spreadsheet.



**BLADE PULL**

This specification is also known as drawbar pull. This spec can be calculated as follows:

Variables:

Rear weight of machine =  $Wr$

Tire traction coefficient =  $T$  (Look up the table entitled “Coefficient of Traction Factors”)

$$Wr \times T = \text{Blade Pull}$$

Example problem:

Calculate the blade pull for a 140M Global Version machine operating in a quarry pit...

*Metric*

$RW = 10\,501\text{ kg}$

$T = 0.65$

$$10\,501 \times 0.65 = 6825.65$$

*English*

$RW = 23,151\text{ lb}$

$T = 0.65$

$$23,151 \times 0.65 = 15,048.15$$

**BLADE DOWN PRESSURE**

This spec can be calculated as follows:

Variables:

Blade to front axle length =  $BA$

Wheel base length =  $WB$

Weight on front wheels =  $FW$

Blade down pressure =  $BD$

$$\frac{WB}{(WB - BA)} \times FW = BD$$

Example problem:

Calculate the blade down pressure for a 140M Global Version machine...

*Metric*

$BA = 2565\text{ mm}$        $FW = 4223\text{ kg}$

$WB = 6086\text{ mm}$        $BD = ?$

$$\frac{6086}{(6086 - 2565)} \times 4223 = 7299\text{ kg}$$

*English*

$BA = 101\text{ in}$

$FW = 9310\text{ lb}$

$WB = 240\text{ in}$

$BD = ?$

$$\frac{240}{(240 - 101)} \times 9310 = 16,075\text{ lb}$$

This specification is only a minor indicator of a motor grader’s productivity. It alone gives no measure of overall machine productivity. When considering motor grader production you need an optimum balance between the machine’s front and rear weights. If a machine has too much weight on the front axle, it might have a high blade down pressure spec. It will, however, lack the essential rear weight and traction needed to push through the load. Too much weight in the rear and it will not have the necessary weight in the front during heavy cuts to maintain proper steering control.

Cat machines are built with this optimum balance in mind. A Cat Motor Grader is engineered with the proper weight distribution necessary for maximum productivity.

**Effective Blade Length\***

		Moldboard							
		3.66 m (12')		4.27 m (14')		4.88 m (16')		7.32 m (24')	
Angle°		m	ft	m	ft	m	ft	m	ft
	0°	3.66	12.00	4.27	14.00	4.88	16.00	7.32	24.00
	5°	3.64	11.95	4.25	13.95	4.86	15.94	7.29	23.91
	10°	3.60	11.82	4.20	13.79	4.80	15.76	7.21	23.64
	15°	3.53	11.59	4.12	13.52	4.71	15.45	7.07	23.18
	20°	3.44	11.28	4.01	13.16	4.58	15.04	6.87	22.55
	25°	3.32	10.88	3.87	12.69	4.42	14.50	6.63	21.75
	30°	3.17	10.39	3.69	12.12	4.22	13.86	6.33	20.78
	35°	3.00	9.83	3.50	11.47	4.00	13.11	5.99	19.66
	40°	2.80	9.19	3.27	10.72	3.74	12.26	5.61	18.39
45°	2.59	8.49	3.02	9.90	3.45	11.31	5.17	16.97	

\*Effective blade length is the amount of blade coverage the machine is capable of when the blade is at a given angle.

## EXTREME SLOPE OPERATION

There are two ways of defining slope work. The slope perpendicular to the machine's direction of travel is commonly referred to as "Side Sloping." The slope parallel to the machine's direction of travel — the machine's ability to travel up or down terrain, is commonly referred to as "Gradeability."

Side Sloping capability for our M Series graders is somewhat subjective, but general agreement among professional operators is that working on a slope ratio of 2.5:1 (21.8 degrees) is the safe limit ... an experienced operator may be able to operate on a 2:1 (28 degrees) slope. Many factors influence this limit such as operator experience, machine configuration, tires and soil conditions, but a 2.5:1 is achievable. Further, a 3:1 slope is the approximate maximum side slope a grader can work on in straight frame configuration. The steeper side slopes all require the machine be articulated to safely navigate the slope.

Gradeability is approximately 22 degrees. This is established by the grader's ability to stop without skidding the tires while moving downhill. The motor grader can, however, *climb* grades steeper than 22 degrees. The traction coefficient is the critical factor in determining whether a grader can safely navigate the slope. Caterpillar recommends that you never climb a slope steeper than you can safely descend.

Maximum lubrication angle: We have measured the graders on a tilt table and pump cavitation occurs around 45 degrees (100% or 1:1). This is beyond the grade or slope a motor grader can operate on.

When working side hills and slopes, consideration should be given to the following important points.

- **Speed of Travel** — At higher speeds, inertia forces tend to make the grader less stable.
- **Roughness of Terrain or Surface** — Ample allowance should be made where the terrain or surface is uneven.
- **Mounted Equipment** — Mounted attachments such as front plows, snow wings, rippers and other mounted equipment cause the tractor to balance differently.
- **Nature of Surface** — New earthen fills may give way with the weight of the grader. Rocky surfaces may promote side slipping of grader.
- **Excessive Loads or Side Draft** — This may cause wheel slippage, where the downhill tires "dig in," increasing the angle of grader.
- **Tire Selection and Maintenance** — Consideration should be given to proper tire selection and air pressure. For more information, consult Caterpillar publications — Motor Grader Tire Selection Guide and Operation and Maintenance Manual.
- **Drawbar, Circle and Blade Position** — The position of the blade can affect the stability of the machine.
- **Articulation Angle** — Articulation angle can affect the stability of the machine.
- **Wheel Lean Angle** — Wheel lean angle can affect the stability of the machine.

**NOTE:** Safe operation on steep slopes may require special machine maintenance as well as excellent operator skill and proper equipment setup for the specific application. Consult Caterpillar publications for further operating tips — Operation & Maintenance Manual, Motor Grader Application Guide, and the Grade Comparison Chart in the Tables section of this Performance Handbook.

<b>Work Tool</b>	<b>120M</b>	<b>12M</b>	<b>140M/ 140M2</b>	<b>160M/ 160M2</b>	<b>14M</b>	<b>16M</b>	<b>24M</b>
Lift Group	x	x	x	x	x	x	—
V-Plow	x	x	x	x	x	x	—
One Way Plow	x	x	x	x	x	x	—
Manual Reversible Plow	x	x	x	x	x	x	—
Hydraulic Reversible Plow	x	x	x	x	x	x	—
Snow Wing	x	x	x	x	x	x	—
Mid Mount Scarifier	x	x	x	x	—	—	—
Front Scarifier	x	x	x	x	—	—	—
Manual Angle Blade	x	x	x	x	x	x	—
Hydraulic Angle Blade	x	x	x	x	x	x	—
Straight Blade	x	x	x	x	x	x	—

This list is not all-inclusive.

See Price Lists, Cat Work Tools (Cat WT) Price List, and your Cat dealer for special attachment needs.

Attachments for Cat Motor Graders require additional hydraulics.

Most front-mounted attachments require a Quick Attach-Detach Parallel Lift Group.

Contact your Cat dealer for details.

# SKID STEER LOADERS MULTI TERRAIN LOADERS COMPACT TRACK LOADERS

## CONTENTS

### SKID STEER LOADERS/ MULTI TERRAIN LOADERS/ COMPACT TRACK LOADERS

Features . . . . .	3-1
SSL Specifications . . . . .	3-2
SSL Performance Data . . . . .	3-5
SSL Dimensions . . . . .	3-34
SSL Work Tool Compatibility . . . . .	3-37
MTL Specifications . . . . .	3-40
MTL Performance Data . . . . .	3-42
MTL Dimensions . . . . .	3-57
MTL Work Tool Compatibility . . . . .	3-59
CTL Specifications . . . . .	3-62
CTL Performance Data . . . . .	3-63
CTL Dimensions . . . . .	3-72
CTL Work Tool Compatibility . . . . .	3-73
Work Tools:	
Augers . . . . .	3-76
Brushcutters . . . . .	3-79
Cold Planers . . . . .	3-81
Landscape Tillers . . . . .	3-84
Landscape Rakes . . . . .	3-86
Mulchers . . . . .	3-88
Power Box Rakes . . . . .	3-90
Trenchers . . . . .	3-92
Vibratory Compactors . . . . .	3-95
Brooms . . . . .	3-97
Stump Grinders . . . . .	3-100
Angle Blades . . . . .	3-103
Backhoes . . . . .	3-104
Material Handling Arm . . . . .	3-105
Snow Blowers . . . . .	3-106
Wheel Saws . . . . .	3-107

### Features:

- **Cat® engines** provide high horsepower, torque and S•O•S™ oil sampling ports standard.
- **Sealed and pressurized cab** option for C Series models provides optimum operator comfort.
- **Ergonomically designed cab** provides maximum operator comfort and visibility.
- **Low-effort** joystick controls, armrest and retractable seat belt for easy operation.
- **Seat mounted controls** are standard for C Series models.
- **Deep skid resistant steps** and two tilt cylinders makes egress/ingress easy.
- **Hand and foot throttle** for continuous or variable engine speed.
- **Anti-stall feature** (B Series) and **Electronic Torque Management** (C Series) provide maximum rimpull and hydraulic power while lugging the engine.
- **High hydraulic horsepower** gets work done quickly.
- **Direct drive hystat pumps** eliminate drive belts.
- **Tilt-up cooling package** provides access to engine compartment.
- **Long life coolant** and extended hour service intervals for low operating costs.
- **Deutsch connectors** are color coded, numbered and protected with nylon braiding.
- **Electro-deposited** or “E” coat corrosion protection for long life.
- **High flow XPS hydraulics** are optional on all C Series machines.
- **High flow hydraulics** optional on 226B2, 242B2 and 257B2.



MODEL	216B2		226B2		232B2	
Flywheel Power: Net	35 kW	<b>48 hp</b>	42 kW	<b>56 hp</b>	42 kW	<b>56 hp</b>
Gross	38 kW	<b>51 hp</b>	46 kW	<b>62 hp</b>	46 kW	<b>62 hp</b>
Engine Model	<b>C2.2</b>		<b>C2.2T</b>		<b>C2.2T</b>	
Rated Engine RPM	<b>3000</b>		<b>3000</b>		<b>3000</b>	
Bore	84 mm	<b>3.3"</b>	84 mm	<b>3.3"</b>	84 mm	<b>3.3"</b>
Stroke	100 mm	<b>3.9"</b>	100 mm	<b>3.9"</b>	100 mm	<b>3.9"</b>
Displacement	2.2 L	<b>134 in<sup>3</sup></b>	2.2 L	<b>134 in<sup>3</sup></b>	2.2 L	<b>134 in<sup>3</sup></b>
No. Cylinders	<b>4</b>		<b>4</b>		<b>4</b>	
One Speed Forward	0-12.7 km/h	<b>0-7.9 mph</b>	0-12.7 km/h	<b>0-7.9 mph</b>	0-11.1 km/h	<b>0-6.9 mph</b>
One Speed Reverse	0-12.7 km/h	<b>0-7.9 mph</b>	0-12.7 km/h	<b>0-7.9 mph</b>	0-11.1 km/h	<b>0-6.9 mph</b>
Hydraulic Cycle Time, Empty Bucket:	<b>Seconds</b>		<b>Seconds</b>		<b>Seconds</b>	
Raise	<b>2.7</b>		<b>2.7</b>		<b>3.0</b>	
Dump	<b>2.2</b>		<b>2.2</b>		<b>2.2</b>	
Lower (Empty, Float Down)	<b>2.8</b>		<b>2.8</b>		<b>3.0</b>	
Total	<b>7.7</b>		<b>7.7</b>		<b>8.2</b>	
Tread Width	1244 mm	<b>4'1"</b>	1244 mm	<b>4'1"</b>	1244 mm	<b>4'1"</b>
Width Over Tires	1525 mm	<b>5'0"</b>	1525 mm	<b>5'0"</b>	1525 mm	<b>5'0"</b>
Ground Clearance	195 mm	<b>8.0"</b>	195 mm	<b>8.0"</b>	145 mm	<b>5.7"</b>
Fuel Tank Capacity	58 L	<b>15.4 U.S. gal</b>	58 L	<b>15.4 U.S. gal</b>	58 L	<b>15.4 U.S. gal</b>
Hydraulic Tank Capacity	35 L	<b>9.2 U.S. gal</b>	35 L	<b>9.2 U.S. gal</b>	35 L	<b>9.2 U.S. gal</b>
Hydraulic System Capacity (includes tank)	55 L	<b>14.5 U.S. gal</b>	55 L	<b>14.5 U.S. gal</b>	55 L	<b>14.5 U.S. gal</b>
Hydraulic Pump Capacity	60 L/min	<b>15.6 gpm</b>	60 L/min	<b>15.6 gpm</b>	60 L/min	<b>15.6 gpm</b>



MODEL	236B2		242B2		252B2	
Flywheel Power: Net	53 kW	71 hp	42 kW	56 hp	53 kW	71 hp
Gross	56 kW	75 hp	46 kW	62 hp	56 kW	75 hp
Engine Model	C3.4 DIT		C2.2T		C3.4 DIT	
Rated Engine RPM	2500		3000		2500	
Bore	94 mm	3.7"	84 mm	3.3"	94 mm	3.7"
Stroke	120 mm	4.7"	100 mm	3.9"	120 mm	4.7"
Displacement	3.3 L	201 in <sup>3</sup>	2.2 L	134 in <sup>3</sup>	3.3 L	201 in <sup>3</sup>
No. Cylinders	4		4		4	
One Speed Forward	0-12.1 km/h	0-7.5 mph	0-12 km/h	0-7.5 mph	0-11.9 km/h	0-7.4 mph
Two Speed Forward	0-18.1 km/h	0-11.2 mph	—	—	0-17.8 km/h	0-11 mph
One Speed Reverse	0-12.1 km/h	0-7.5 mph	0-12 km/h	0-7.5 mph	0-11.9 km/h	0-7.4 mph
Two Speed Reverse	0-18.1 km/h	0-11.2 mph	—	—	0-17.8 km/h	0-11 mph
Hydraulic Cycle Time, Empty Bucket:	<b>Seconds</b>		<b>Seconds</b>		<b>Seconds</b>	
Raise	2.7		3.0		4.8	
Dump	2.2		2.2		2.2	
Lower (Empty, Float Down)	2.8		3.0		3.6	
Total	7.7		8.2		10.6	
Tread Width	1514 mm	5'0"	1362 mm	4'6"	1514 mm	5'0"
Width Over Tires	1676 mm	5'6"	1676 mm	5'6"	1829 mm	6'0"
Ground Clearance	235 mm	9.0"	178 mm	7.0"	196 mm	7.7"
Fuel Tank Capacity	90 L	23.8 U.S. gal	58 L	15.3 U.S. gal	90 L	23.8 U.S. gal
Hydraulic Tank Capacity	35 L	9.2 U.S. gal	35 L	9.2 U.S. gal	35 L	9.2 U.S. gal
Hydraulic System Capacity (includes tank)	52 L	13.7 U.S. gal	55 L	14.5 U.S. gal	53 L	14 U.S. gal
Hydraulic Pump Capacity	77 L/min	20.3 gpm	60 L/min	15.6 gpm	77 L/min	20.3 gpm



MODEL	246C		256C		262C		272C	
Flywheel Power: Net	54 kW	<b>73 hp</b>	61 kW	<b>82 hp</b>	61 kW	<b>82 hp</b>	67 kW	<b>90 hp</b>
Gross	56 kW	<b>75 hp</b>	63 kW	<b>84 hp</b>	63 kW	<b>84 hp</b>	70 kW	<b>94 hp</b>
Engine Model	<b>C3.4 DIT</b>		<b>C3.4 DIT</b>		<b>C3.4 DIT</b>		<b>C3.4 DIT</b>	
Rated Engine RPM	<b>2500</b>		<b>2500</b>		<b>2500</b>		<b>2500</b>	
Bore	94 mm	<b>3.7"</b>	94 mm	<b>3.7"</b>	94 mm	<b>3.7"</b>	94 mm	<b>3.7"</b>
Stroke	120 mm	<b>4.7"</b>	120 mm	<b>4.7"</b>	120 mm	<b>4.7"</b>	120 mm	<b>4.7"</b>
Displacement	3.3 L	<b>201 in<sup>3</sup></b>	3.3 L	<b>201 in<sup>3</sup></b>	3.3 L	<b>201 in<sup>3</sup></b>	3.3 L	<b>201 in<sup>3</sup></b>
No. Cylinders	<b>4</b>		<b>4</b>		<b>4</b>		<b>4</b>	
One Speed Forward	0-12.5 km/h	<b>0-7.7 mph</b>	0-12.5 km/h	<b>0-7.7 mph</b>	0-12.5 km/h	<b>0-7.7 mph</b>	0-11.6 km/h	<b>0-7.2 mph</b>
Two Speed Forward	0-19.3 km/h	<b>0-12 mph</b>	0-19.3 km/h	<b>0-12 mph</b>	0-19.3 km/h	<b>0-12 mph</b>	0-16.1 km/h	<b>0-10 mph</b>
One Speed Reverse	0-12.5 km/h	<b>0-7.7 mph</b>	0-12.5 km/h	<b>0-7.7 mph</b>	0-12.5 km/h	<b>0-7.7 mph</b>	0-11.6 km/h	<b>0-7.2 mph</b>
Two Speed Reverse	0-19.3 km/h	<b>0-12 mph</b>	0-19.3 km/h	<b>0-12 mph</b>	0-19.3 km/h	<b>0-12 mph</b>	0-16.1 km/h	<b>0-10 mph</b>
Hydraulic Cycle Time, Empty Bucket:	<b>Seconds</b>		<b>Seconds</b>		<b>Seconds</b>		<b>Seconds</b>	
Raise (HF)	<b>3.1 (3.1)</b>		<b>3.1 (3.1)</b>		<b>4.7 (4.5)</b>		<b>4.7 (4.5)</b>	
Dump (HF)	<b>2.5 (2.5)</b>		<b>2.5 (2.5)</b>		<b>2.5 (2.5)</b>		<b>2.5 (2.5)</b>	
Lower (Empty, Float Down) (HF)	<b>4.0 (3.6)</b>		<b>4.0 (3.6)</b>		<b>4.6 (4.7)</b>		<b>4.6 (4.7)</b>	
Total (HF)	<b>9.6 (9.2)</b>		<b>9.6 (9.2)</b>		<b>11.8 (11.7)</b>		<b>11.8 (11.7)</b>	
Tread Width (HF)	1371 mm	<b>4'6"</b>	1371 mm	<b>4'6"</b>	1371 mm	<b>4'6"</b>	1371 mm	<b>4'6"</b>
	(1524 mm)	<b>(5'0")</b>	(1524 mm)	<b>(5'0")</b>	(1524 mm)	<b>(5'0")</b>	(1524 mm)	<b>(5'0")</b>
Width Over Tires	1676 mm	<b>5'6"</b>	1676 mm	<b>5'6"</b>	1676 mm	<b>5'6"</b>	1676 mm	<b>5'6"</b>
Ground Clearance	225 mm	<b>8.9"</b>	225 mm	<b>8.9"</b>	225 mm	<b>8.9"</b>	225 mm	<b>8.9"</b>
Fuel Tank Capacity	98 L	<b>26 U.S. gal</b>	98 L	<b>26 U.S. gal</b>	98 L	<b>26 U.S. gal</b>	98 L	<b>26 U.S. gal</b>
Hydraulic Tank Capacity	42 L	<b>11 U.S. gal</b>	42 L	<b>11 U.S. gal</b>	42 L	<b>11 U.S. gal</b>	42 L	<b>11 U.S. gal</b>
Hydraulic System Capacity (includes tank)	57 L	<b>15 U.S. gal</b>	57 L	<b>15 U.S. gal</b>	57 L	<b>15 U.S. gal</b>	57 L	<b>15 U.S. gal</b>
Hydraulic Pump Capacity	84 L/min	<b>22 gpm</b>	84 L/min	<b>22 gpm</b>	84 L/min	<b>22 gpm</b>	84 L/min	<b>22 gpm</b>

HF = High Flow

Performance Data  
 ● 216B2/226B2/226B2 HF

Skid Steer Loaders

Bucket Type	General Purpose						Multi-Purpose		
	1520 mm (60") 10 x 16.5			1680 mm (66") 10 x 16.5			1520 mm (60") 10 x 16.5		
Bucket Width Tire Size	Holes Only	Bolt-on Edge	Bolt-on Teeth	Holes Only	Bolt-on Edge	Bolt-on Teeth	Holes Only	Bolt-on Edge	
Ground Engaging Type	165-6152	152-0224	152-0223	165-6153	152-0226	152-0225	154-5004	154-5045	
Rated bucket capacity	m <sup>3</sup> yd <sup>3</sup>	0.36 0.47	0.37 0.48	0.36 0.47	0.40 0.52	0.40 0.52	0.41 0.53	0.30 0.41	
Struck capacity	m <sup>3</sup> yd <sup>3</sup>	0.26 0.34	0.27 0.35	0.26 0.34	0.29 0.38	0.29 0.38	0.29 0.38	0.22 0.29	
Width	mm in	1576 62	1586 62	1576 62	1730 68	1740 68	1730 68	1595 63	
Dump clearance at maximum lift/dump	mm in	2133 84	2103 83	2069 81	2130 84	2100 83	2066 81	2122 84	
Reach at maximum lift/dump	mm in	546 21	557 22	620 24	549 22	560 22	623 25	560 22	
Floor angle at maximum lift/dump	degrees	39.9°	39.9°	39.9°	40°	40°	40°	40.2°	
Floor angle at maximum lift/rack back	degrees	96.7°	96.7°	96.7°	96.5°	96.5°	96.5°	96.4°	
Clearance at maximum lift/level bucket	mm in	2658 105	2642 104	2657 105	2656 105	2640 104	2655 105	2655 105	
Hinge pin height at maximum lift	mm in	2849 112	2849 112	2849 112	2849 112	2849 112	2849 112	2849 112	
Maximum overall height	mm in	3762 148	3790 149	3860 152	3759 148	3787 149	3857 152	3746 147	
Reach at level lift arm/bucket	mm in	1333 52	1361 54	1431 56	1335 53	1363 54	1433 56	1346 53	
Maximum floor angle at minimum lift	degrees	26.1°	26.1°	26.1°	26°	26°	26°	25.8°	
Dig depth with level bucket	mm in	0 0.0	16 0.6	1 0.0	0 0.0	16 0.6	1 0.0	0 0.0	
Overall length with bucket on ground	mm in	3286 129	3314 130	3384 133	3286 129	3314 130	3384 133	3290 130	
Front clearance circle radius (with bucket)	mm in	1989 78	2016 79	2079 82	2021 80	2048 81	2110 83	1992 78	
Tipping load	216B2	kg lb	1213 2673	1158 2554	1187 2616	1194 2631	1140 2513	1171 2582	1074 2367
	226B2	kg lb	1293 2850	1238 2729	1267 2792	1274 2808	1219 2688	1251 2759	1153 2541
	226B2 HF	kg lb	1382 3047	1326 2924	1356 2988	1363 3004	1308 2883	1340 2954	1240 2734
Breakout force — lift	216B2	kg lb	1437 3168	1389 3062	1421 3132	1424 3140	1374 3030	1408 3104	1330 2932
	226B2	kg lb	1437 3168	1389 3062	1421 3132	1424 3140	1374 3030	1408 3104	1330 2932
	226B2 HF	kg lb	1425 3142	1377 3036	1409 3105	1412 3113	1363 3004	1396 3078	1318 2905
Breakout force — tilt	216B2	kg lb	1700 3747	1596 3518	1681 3705	1694 3735	1590 3506	1677 3697	1631 3596
	226B2	kg lb	1700 3747	1596 3518	1681 3705	1694 3735	1590 3506	1677 3697	1631 3596
	226B2 HF	kg lb	1700 3747	1596 3518	1681 3706	1694 3735	1590 3506	1677 3697	1631 3596
Operating weight	216B2	kg lb	2637 5814	2667 5880	2654 5850	2654 5851	2687 5924	2670 5887	2799 6103
	226B2	kg lb	2669 5885	2699 5951	2686 5921	2686 5922	2719 5994	2702 5958	2801 6174
	226B2 HF	kg lb	2761 6087	2791 6153	2777 6123	2778 6124	2811 6196	2794 6160	2892 6376

HF = High Flow



Bucket Type		Multi-Purpose				Dirt					
		1520 mm (60")	1680 mm (66")		1520 mm (60")	1680 mm (66")					
Bucket Width		10 x 16.5	10 x 16.5		10 x 16.5	10 x 16.5					
Tire Size		10 x 16.5	10 x 16.5		10 x 16.5	10 x 16.5					
Ground Engaging Type		Bolt-on Teeth	Holes Only	Bolt-on Edge	Bolt-on Teeth	Holes Only	Bolt-on Edge	Holes Only	Bolt-on Edge		
Bucket Assembly No.		154-5046	154-5008	154-5047	154-5048	165-6156	152-0231	165-6157	152-0232		
Rated bucket capacity	m <sup>3</sup>	0.30	0.33	0.33	0.34	0.34	0.35	0.37	0.38		
	yd <sup>3</sup>	0.39	0.43	0.43	0.44	0.44	0.46	0.48	0.49		
Struck capacity	m <sup>3</sup>	0.22	0.24	0.25	0.24	0.25	0.25	0.27	0.27		
	yd <sup>3</sup>	0.29	0.31	0.33	0.31	0.33	0.33	0.35	0.35		
Width	mm	1595	1749	1749	1749	1576	1586	1730	1740		
	in	63	69	69	69	62	62	68	69		
Dump clearance at maximum lift/dump	mm	2058	2122	2092	2058	2169	2140	2169	2140		
	in	81	84	82	81	85	84	85	84		
Reach at maximum lift/dump	mm	634	560	571	634	505	520	505	520		
	in	25	22	22	25	20	20	20	20		
Floor angle at maximum lift/dump	degrees	40.2°	40.2°	40.2°	40.2°	39.9°	39.9°	39.9°	39.9°		
	degrees	96.4°	96.4°	96.4°	96.4°	96.7°	96.7°	96.7°	96.7°		
Clearance at maximum lift/level bucket	mm	2654	2655	2683	2654	2661	2648	2661	2648		
	in	104	105	106	104	105	104	105	104		
Hinge pin height at maximum lift	mm	2849	2849	2849	2849	2849	2849	2849	2849		
	in	112	112	112	112	112	112	112	112		
Maximum overall height	mm	3844	3746	3774	3844	3709	3739	3709	3739		
	in	151	147	149	151	146	147	146	147		
Reach at level lift arm/bucket	mm	1444	1346	1374	1444	1280	1310	1280	1310		
	in	57	53	54	57	50	52	50	52		
Maximum floor angle at minimum lift	degrees	25.8°	25.8°	25.8°	25.8°	26.1°	26.1°	26.1°	26.1°		
	degrees	25.8°	25.8°	25.8°	25.8°	26.1°	26.1°	26.1°	26.1°		
Dig depth with level bucket	mm	1	0	16	1	0	16	0	16		
	in	0.0	0.0	0.6	0.0	0.0	0.6	0.0	0.6		
Overall length with bucket on ground	mm	3388	3290	3318	3388	3233	3263	3233	3263		
	in	133	130	131	133	127	128	127	128		
Front clearance circle radius (with bucket)	mm	2083	1992	2020	2113	1940	1970	1970	2000		
	in	82	78	80	83	76	78	78	79		
Tipping load	216B2	kg	1058	1053	1001	1032	1304	1251	1280	1223	
		lb	2332	2321	2207	2275	2875	2758	2823	2696	
	226B2	kg	1137	1132	1079	1111	1386	1332	1363	1304	
		lb	2506	2495	2379	2449	3056	2937	3004	2875	
	226B2 HF	kg	1225	1219	1166	1199	1477	1422	1453	1394	
		lb	2700	2688	2571	2643	3257	3136	3204	3073	
	Breakout force — lift	216B2	kg	1316	1314	1265	1298	1515	1466	1495	1444
			lb	2900	2896	2789	2860	3339	3232	3295	3183
		226B2	kg	1316	1314	1265	1298	1515	1466	1495	1444
lb			2900	2896	2789	2860	3339	3232	3295	3183	
226B2 HF		kg	1304	1302	1253	1286	1502	1454	1482	1432	
		lb	2874	2870	2763	2834	3312	3206	3268	3156	
Breakout force — tilt		216B2	kg	1620	1618	1518	1601	1853	1740	1842	1727
			lb	3571	3568	3346	3529	4084	3835	4061	3807
		226B2	kg	1620	1618	1518	1601	1853	1740	1842	1727
	lb		3571	3568	3346	3529	4084	3835	4061	3807	
	226B2 HF	kg	1620	1618	1518	1601	1853	1740	1842	1727	
		lb	3571	3568	3346	3529	4084	3835	4061	3807	
	Operating weight	216B2	kg	2785	2787	2820	2803	2579	2609	2604	2637
			lb	6139	6144	6216	6180	5685	5751	5740	5813
		226B2	kg	2817	2819	2852	2835	2611	2641	2636	2669
lb			6210	6215	6287	6251	5756	5822	5811	5883	
226B2 HF		kg	2909	2911	2943	2927	2703	2732	2728	2760	
		lb	6412	6417	6489	6453	5958	6024	6013	6085	

HF = High Flow

Work Tool		Pallet Fork				
		910 mm (36")	1070 mm (42")	1220 mm (48")		
Tine Length		910 mm (36")	1070 mm (42")	1220 mm (48")		
Tire Size		10 x 16.5	10 x 16.5	10 x 16.5		
Carriage Assembly No.		242-9998	242-9999	243-0000		
Carriage overall width without step	mm	1157	1157	1157		
	in	45	45	45		
Carriage step additional width	mm	108	108	108		
	in	4.25	4.25	4.25		
Carriage height above blade top	mm	923.5	923.5	923.5		
	in	36.4	36.4	36.4		
Blade surface height at maximum height	mm	2741	2741	2741		
	in	107.9	107.9	107.9		
Shank front face reach at maximum height	mm	290	290	290		
	in	11.4	11.4	11.4		
Blade surface height at level lift arms	mm	1383	1383	1383		
	in	54.4	54.4	54.4		
Shank front face reach at level lift arms	mm	743	743	743		
	in	29.3	29.3	29.3		
Blade surface height at minimum lift	mm	91	91	91		
	in	3.6	3.6	3.6		
Shank front face reach at minimum lift	mm	345	345	345		
	in	13.6	13.6	13.6		
Overall length at minimum lift, level tine	mm	3602	3762	3912		
	in	141.8	148.1	154.0		
Tipping load	216B2	kg	949	894	846	
		lb	2093	1970	1864	
	226B2	kg	1012	953	903	
		lb	2230	2102	1990	
	226B2 HF	kg	1083	1022	968	
		lb	2388	2252	2135	
	Operating weight	216B2	kg	2620	2630	2640
			lb	5775	5798	5820
		226B2	kg	2652	2662	2672
lb			5846	5869	5890	
226B2 HF		kg	2743	2754	2763	
		lb	6048	6071	6092	

HF = High Flow

Bucket Type	General Purpose								
	1520 mm (60") 10 x 16.5			1680 mm (66") 10 x 16.5			1830 mm (72") 10 x 16.5		
Bucket Width Tire Size									
Ground Engaging Type	Holes Only	Bolt-on Edge	Bolt-on Teeth	Holes Only	Bolt-on Edge	Bolt-on Teeth	Holes Only	Bolt-on Edge	Bolt-on Teeth
Bucket Assembly No.	165-6152	152-0224	152-0223	165-6153	152-0226	152-0225	165-6154	152-0229	152-0228
Rated bucket capacity	m <sup>3</sup> yd <sup>3</sup>	0.36 0.47	0.37 0.48	0.36 0.47	0.40 0.52	0.40 0.52	0.41 0.53	0.44 0.57	0.44 0.59
Struck capacity	m <sup>3</sup> yd <sup>3</sup>	0.26 0.34	0.27 0.35	0.26 0.34	0.29 0.38	0.29 0.38	0.29 0.38	0.32 0.42	0.32 0.42
Width	mm in	1576 62	1586 62	1576 62	1730 68	1740 68	1730 68	1883 74	1893 75
Dump clearance at maximum lift/dump	mm in	2220 87	2189 86	2148 85	2220 87	2189 86	2148 85	2220 87	2189 86
Reach at maximum lift/dump	mm in	759 30	766 30	822 32	759 30	766 30	822 32	759 30	766 30
Floor angle at maximum lift/dump	degrees	49.5°	49.5°	49.5°	49.5°	49.5°	49.5°	49.5°	49.5°
Floor angle at maximum lift/rack back	degrees	86.9°	86.9°	86.9°	86.9°	86.9°	86.9°	86.9°	86.9°
Clearance at maximum lift/level bucket	mm in	2831 111	2815 111	2830 111	2831 111	2815 111	2830 111	2831 111	2815 111
Hinge pin height at maximum lift	mm in	3026 119	3026 119	3026 119	3026 119	3026 119	3026 119	3026 119	3026 119
Maximum overall height	mm in	3907 154	3934 155	4004 158	3907 154	3934 155	4004 158	3907 154	3934 155
Reach at level lift arm/bucket	mm in	1356 53	1384 54	1453 57	1356 53	1384 54	1453 57	1356 53	1384 54
Maximum floor angle at minimum lift	degrees	25.4°	25.4°	25.4°	25.4°	25.4°	25.4°	25.4°	25.4°
Dig depth with level bucket	mm in	4 0.2	21 0.8	5 0.2	4 0.2	21 0.8	5 0.2	4 0.2	21 0.8
Overall length with bucket on ground	mm in	3490 137	3518 139	3588 141	3490 137	3518 139	3588 141	3490 137	3518 139
Front clearance circle radius (with bucket)	mm in	2192 86	2224 88	2259 89	2221 87	2253 89	2286 90	2252 89	2283 90
Tipping load	kg lb	1754 3866	1694 3734	1726 3806	1733 3821	1676 3694	1711 3772	1725 3804	1664 3668
Breakout force — lift	kg lb	1662 3665	1614 3558	1646 3628	1649 3635	1599 3525	1633 3600	1642 3621	1590 3505
Breakout force — tilt	kg lb	1699 3745	1595 3517	1680 3704	1693 3733	1590 3504	1676 3695	1689 3723	1583 3491
Operating weight	kg lb	3090 6812	3120 6878	3106 6848	3107 6849	3139 6921	3123 6885	3114 6866	3150 6944

Bucket Type	Multi-Purpose								
	1520 mm (60") 10 x 16.5			1680 mm (66") 10 x 16.5			1830 mm (72") 10 x 16.5		
Bucket Width Tire Size									
Ground Engaging Type	Holes Only	Bolt-on Edge	Bolt-on Teeth	Holes Only	Bolt-on Edge	Bolt-on Teeth	Holes Only	Bolt-on Edge	Bolt-on Teeth
Bucket Assembly No.	154-5004	154-5045	154-5046	154-5008	154-5047	154-5048	154-5010	154-5049	154-5050
Rated bucket capacity	m <sup>3</sup> yd <sup>3</sup>	0.30 0.39	0.31 0.41	0.30 0.39	0.33 0.43	0.33 0.43	0.34 0.44	0.37 0.48	0.37 0.48
Struck capacity	m <sup>3</sup> yd <sup>3</sup>	0.22 0.29	0.22 0.29	0.22 0.29	0.24 0.31	0.25 0.33	0.24 0.31	0.27 0.35	0.28 0.35
Width	mm in	1595 63	1595 63	1595 63	1749 69	1749 69	1749 69	1902 75	1902 75
Dump clearance at maximum lift/dump	mm in	2218 87	2287 90	2143 84	2218 87	2287 90	2143 84	2218 87	2287 90
Reach at maximum lift/dump	mm in	762 30	769 30	825 32	762 30	769 30	825 32	762 30	769 30
Floor angle at maximum lift/dump	degrees	49.6°	49.6°	49.6°	49.6°	49.6°	49.6°	49.6°	49.6°
Floor angle at maximum lift/rack back	degrees	86.8°	86.8°	86.8°	86.8°	86.8°	86.8°	86.8°	86.8°
Clearance at maximum lift/level bucket	mm in	2834 112	2818 111	2833 112	2834 112	2818 111	2833 112	2834 112	2818 111
Hinge pin height at maximum lift	mm in	3026 119	3026 119	3026 119	3026 119	3026 119	3026 119	3026 119	3026 119
Maximum overall height	mm in	3911 154	3938 155	4008 158	3911 154	3938 155	4008 158	3911 154	3938 155
Reach at level lift arm/bucket	mm in	1360 54	1387 55	1457 57	1360 54	1387 55	1457 57	1360 54	1387 55
Maximum floor angle at minimum lift	degrees	25.3°	25.3°	25.3°	25.3°	25.3°	25.3°	25.3°	25.3°
Dig depth with level bucket	mm in	3 0.1	19 0.7	4 0.2	3 0.1	19 0.7	4 0.2	3 0.1	19 0.7
Overall length with bucket on ground	mm in	3494 138	3522 139	3591 141	3494 138	3522 139	3591 141	3494 138	3522 139
Front clearance circle radius (with bucket)	mm in	2182 86	2214 87	2249 89	2211 87	2243 88	2276 90	2242 88	2273 89
Tipping load	kg lb	1606 3542	1560 3439	1591 3508	1586 3495	1530 3373	1566 3451	1568 3456	1509 3327
Breakout force — lift	kg lb	1552 3422	1508 3324	1538 3390	1536 3386	1487 3278	1520 3351	1521 3353	1470 3240
Breakout force — tilt	kg lb	1631 3595	1539 3392	1619 3569	1618 3566	1517 3344	1600 3527	1609 3547	1508 3325
Operating weight	kg lb	3221 7101	3251 7167	3237 7137	3239 7142	3272 7214	3256 7178	3258 7182	3294 7262

Bucket Type		Dirt					
		1520 mm (60") 10 x 16.5		1680 mm (66") 10 x 16.5		1830 mm (72") 10 x 16.5	
Bucket Width Tire Size		Holes Only	Bolt-on Edge	Holes Only	Bolt-on Edge	Holes Only	Bolt-on Edge
Ground Engaging Type							
Bucket Assembly No.		165-6156	152-0231	165-6157	152-0232	188-3526	188-2719
Rated bucket capacity	m <sup>3</sup> yd <sup>3</sup>	0.34 <b>0.44</b>	0.35 <b>0.46</b>	0.37 <b>0.48</b>	0.38 <b>0.49</b>	0.41 <b>0.54</b>	0.42 <b>0.55</b>
Struck capacity	m <sup>3</sup> yd <sup>3</sup>	0.25 <b>0.33</b>	0.25 <b>0.33</b>	0.27 <b>0.35</b>	0.27 <b>0.35</b>	0.29 <b>0.38</b>	0.31 <b>0.41</b>
Width	mm in	1576 <b>62</b>	1586 <b>62</b>	1730 <b>68</b>	1740 <b>69</b>	1883 <b>74</b>	1893 <b>75</b>
Dump clearance at maximum lift/dump	mm in	2261 <b>89</b>	2229 <b>88</b>	2261 <b>89</b>	2229 <b>88</b>	2261 <b>89</b>	2229 <b>88</b>
Reach at maximum lift/dump	mm in	724 <b>29</b>	732 <b>29</b>	724 <b>29</b>	732 <b>29</b>	724 <b>29</b>	732 <b>29</b>
Floor angle at maximum lift/dump	degrees	49.5°	49.5°	49.5°	49.5°	49.5°	49.5°
Floor angle at maximum lift/rack back	degrees	86.9°	86.9°	86.9°	86.9°	86.9°	86.9°
Clearance at maximum lift/level bucket	mm in	2831 <b>111</b>	2815 <b>111</b>	2831 <b>111</b>	2815 <b>111</b>	2831 <b>111</b>	2815 <b>111</b>
Hinge pin height at maximum lift	mm in	3026 <b>119</b>	3026 <b>119</b>	3026 <b>119</b>	3026 <b>119</b>	3026 <b>119</b>	3026 <b>119</b>
Maximum overall height	mm in	3854 <b>152</b>	3881 <b>153</b>	3854 <b>152</b>	3881 <b>153</b>	3854 <b>152</b>	3881 <b>153</b>
Reach at level lift arm/bucket	mm in	1302 <b>51</b>	1330 <b>52</b>	1302 <b>51</b>	1330 <b>52</b>	1302 <b>51</b>	1330 <b>52</b>
Maximum floor angle at minimum lift	degrees	25.4°	25.4°	25.4°	25.4°	25.4°	25.4°
Dig depth with level bucket	mm in	4 <b>0.2</b>	20 <b>0.8</b>	4 <b>0.2</b>	20 <b>0.8</b>	4 <b>0.2</b>	20 <b>0.8</b>
Overall length with bucket on ground	mm in	3437 <b>135</b>	3465 <b>136</b>	3437 <b>135</b>	3465 <b>136</b>	3437 <b>135</b>	3465 <b>136</b>
Front clearance circle radius (with bucket)	mm in	2137 <b>84</b>	2169 <b>85</b>	2154 <b>85</b>	2185 <b>86</b>	2198 <b>87</b>	2229 <b>88</b>
Tipping load	kg lb	1858 <b>4095</b>	1799 <b>3966</b>	1834 <b>4043</b>	1771 <b>3904</b>	1827 <b>4027</b>	1760 <b>3879</b>
Breakout force — lift	kg lb	1741 <b>3838</b>	1692 <b>3731</b>	1721 <b>3793</b>	1669 <b>3680</b>	1714 <b>3779</b>	1660 <b>3660</b>
Breakout force — tilt	kg lb	1852 <b>4083</b>	1739 <b>3833</b>	1841 <b>4060</b>	1726 <b>3806</b>	1838 <b>4051</b>	1720 <b>3791</b>
Operating weight	kg lb	3031 <b>6683</b>	3061 <b>6749</b>	3056 <b>6738</b>	3089 <b>6810</b>	3064 <b>6755</b>	3100 <b>6834</b>

Work Tool		Pallet Fork		
		910 mm (36")	1070 mm (42")	1220 mm (48")
<b>Tine Length</b>		<b>910 mm (36")</b>	<b>1070 mm (42")</b>	<b>1220 mm (48")</b>
<b>Tire Size</b>		<b>10 x 16.5</b>	<b>10 x 16.5</b>	<b>10 x 16.5</b>
<b>Carriage Assembly No.</b>		<b>242-9998</b>	<b>242-9999</b>	<b>243-0000</b>
Carriage overall width without step	<b>mm</b>	1157	1157	1157
	<b>in</b>	<b>45</b>	<b>45</b>	<b>45</b>
Carriage step additional width	<b>mm</b>	108	108	108
	<b>in</b>	<b>4.25</b>	<b>4.25</b>	<b>4.25</b>
Carriage height above blade top	<b>mm</b>	924	924	924
	<b>in</b>	<b>36.4</b>	<b>36.4</b>	<b>36.4</b>
Blade surface height at maximum height	<b>mm</b>	2911	2911	2911
	<b>in</b>	<b>114.6</b>	<b>114.6</b>	<b>114.6</b>
Shank front face reach at maximum height	<b>mm</b>	624	624	624
	<b>in</b>	<b>24.6</b>	<b>24.6</b>	<b>24.6</b>
Blade surface height at level lift arms	<b>mm</b>	1506	1506	1506
	<b>in</b>	<b>59.3</b>	<b>59.3</b>	<b>59.3</b>
Shank front face reach at level lift arms	<b>mm</b>	762	762	762
	<b>in</b>	<b>30.0</b>	<b>30.0</b>	<b>30.0</b>
Blade surface height at minimum lift	<b>mm</b>	56	56	56
	<b>in</b>	<b>2.2</b>	<b>2.2</b>	<b>2.2</b>
Shank front face reach at minimum lift	<b>mm</b>	468	468	468
	<b>in</b>	<b>18.4</b>	<b>18.4</b>	<b>18.4</b>
Overall length at minimum lift, level tine	<b>mm</b>	3806	3966	4116
	<b>in</b>	<b>149.8</b>	<b>156.1</b>	<b>162.0</b>
Tipping load	<b>kg</b>	1369	1294	1229
	<b>lb</b>	<b>3018</b>	<b>2852</b>	<b>2708</b>
Operating weight	<b>kg</b>	3072	3083	3092
	<b>lb</b>	<b>6773</b>	<b>6796</b>	<b>6817</b>

Bucket Type	General Purpose						Multi-Purpose		
	1680 mm (66") 12 x 16.5			1830 mm (72") 12 x 16.5			1680 mm (66") 12 x 16.5		
Bucket Width Tire Size	Holes Only	Bolt-on Edge	Bolt-on Teeth	Holes Only	Bolt-on Edge	Bolt-on Teeth	Holes Only	Bolt-on Edge	
Ground Engaging Type									
Bucket Assembly No.	165-6153	152-0226	152-0225	165-6154	152-0229	152-0228	154-5008	154-5047	
Rated bucket capacity	<b>m<sup>3</sup></b> <b>yd<sup>3</sup></b>	0.40 0.52	0.40 0.52	0.41 0.53	0.44 0.57	0.44 0.57	0.45 0.59	0.33 0.43	0.33 0.43
Struck capacity	<b>m<sup>3</sup></b> <b>yd<sup>3</sup></b>	0.29 0.38	0.29 0.38	0.29 0.38	0.32 0.42	0.32 0.42	0.32 0.42	0.24 0.31	0.25 0.33
Width	<b>mm</b> <b>in</b>	1730 68	1740 68	1730 68	1883 74	1893 75	1883 74	1749 69	1749 69
Dump clearance at maximum lift/dump	<b>mm</b> <b>in</b>	2360 92.9	2331 91.8	2299 90.5	2360 92.9	2331 91.8	2299 90.5	2356 92.8	2326 91.6
Reach at maximum lift/dump	<b>mm</b> <b>in</b>	587 23.1	593 23.3	655 25.8	581 22.9	594 23.4	656 25.8	591 23.3	605 23.8
Floor angle at maximum lift/dump	<b>degrees</b>	39.9°	39.9°	39.9°	39.9°	39.9°	39.9°	40.1°	40.1°
Floor angle at maximum lift/rack back	<b>degrees</b>	97.3°	97.3°	97.3°	97.3°	97.3°	97.3°	97.2°	97.2°
Clearance at maximum lift/level bucket	<b>mm</b> <b>in</b>	2904 114.3	2887 113.7	2902 114.3	2904 114.3	2887 113.7	2902 114.3	2905 114.4	2889 113.7
Hinge pin height at maximum lift	<b>mm</b> <b>in</b>	3098 122.0	3227 127.0	3227 127.0	3227 127.0	3227 127.0	3227 127.0	3227 127.0	3227 127.0
Maximum overall height	<b>mm</b> <b>in</b>	4014 158.0	4042 159.1	4112 161.9	4014 158.0	4042 159.1	4111 161.9	4019 158.2	4046 159.3
Reach at level lift arm/bucket	<b>mm</b> <b>in</b>	1409 55.5	1438 56.6	1507 59.3	1409 55.5	1439 56.7	1508 59.4	1419 55.9	1449 57.0
Maximum floor angle at minimum lift	<b>degrees</b>	27.9°	27.9°	27.9°	27.9°	27.9°	27.9°	27.3°	27.3°
Dig depth with level bucket	<b>mm</b> <b>in</b>	0 0	16 0.63	1 0.04	0 0	16 0.63	1 0.04	0 0	16 0.63
Overall length with bucket on ground	<b>mm</b> <b>in</b>	3568 140.5	3596 141.6	3666 144.3	3568 140.5	3596 141.6	3666 144.3	3572 140.6	3600 141.7
Front clearance circle radius (with bucket)	<b>mm</b> <b>in</b>	2134 84.0	2165 85.2	2198 86.5	2166 85.3	2197 86.5	2226 87.6	2136 84.1	2168 85.4
Tipping load	<b>kg</b> <b>lb</b>	1690 3726	1634 3603	1668 3678	1682 3709	1622 3577	1660 3660	1544 3405	1490 3285
Breakout force — lift	<b>kg</b> <b>lb</b>	2032 4481	1976 4357	2016 4445	2025 4465	1968 4339	2009 4430	1919 4231	1864 4110
Breakout force — tilt	<b>kg</b> <b>lb</b>	2303 5078	2178 4802	2286 5041	2299 5069	2173 4791	2284 5036	2226 4908	2105 4642
Operating weight	<b>kg</b> <b>lb</b>	3228 7118	3261 7191	3244 7153	3236 7135	3271 7213	3252 7171	3361 7411	3394 7484

Bucket Type	Multi-Purpose				Dirt				
Bucket Width	1680 mm (66")	1830 mm (72")			1520 mm (60")		1680 mm (66")		
Tire Size	12 x 16.5	12 x 16.5			12 x 16.5		12 x 16.5		
Ground Engaging Type	Bolt-on Teeth	Holes Only	Bolt-on Edge	Bolt-on Teeth	Holes Only	Bolt-on Edge	Holes Only	Bolt-on Edge	
Bucket Assembly No.	154-5048	154-5010	154-5049	154-5050	165-6156	152-0231	165-6157	152-0232	
Rated bucket capacity	<b>m<sup>3</sup></b> <b>yd<sup>3</sup></b>	0.34 <b>0.44</b>	0.37 <b>0.48</b>	0.37 <b>0.48</b>	0.37 <b>0.48</b>	0.34 <b>0.44</b>	0.35 <b>0.46</b>	0.37 <b>0.48</b>	0.38 <b>0.49</b>
Struck capacity	<b>m<sup>3</sup></b> <b>yd<sup>3</sup></b>	0.24 <b>0.31</b>	0.27 <b>0.35</b>	0.28 <b>0.36</b>	0.27 <b>0.35</b>	0.25 <b>0.33</b>	0.25 <b>0.33</b>	0.27 <b>0.35</b>	0.27 <b>0.35</b>
Width	<b>mm</b> <b>in</b>	1749 <b>69</b>	1902 <b>75</b>	1902 <b>75</b>	1902 <b>75</b>	1576 <b>62</b>	1586 <b>62</b>	1730 <b>68</b>	1740 <b>69</b>
Dump clearance at maximum lift/dump	<b>mm</b> <b>in</b>	2292 <b>90.2</b>	2356 <b>92.8</b>	2326 <b>91.6</b>	2292 <b>90.2</b>	2398 <b>94.4</b>	2369 <b>93.3</b>	2398 <b>94.4</b>	2369 <b>93.3</b>
Reach at maximum lift/dump	<b>mm</b> <b>in</b>	665 <b>26.2</b>	591 <b>23.3</b>	605 <b>23.8</b>	665 <b>26.2</b>	540 <b>21.3</b>	554 <b>21.8</b>	541 <b>21.3</b>	555 <b>21.9</b>
Floor angle at maximum lift/dump	<b>degrees</b>	<b>40.1°</b>	<b>40.1°</b>	<b>40.1°</b>	<b>40.1°</b>	<b>39.9°</b>	<b>39.9°</b>	<b>39.9°</b>	<b>39.9°</b>
Floor angle at maximum lift/rack back	<b>degrees</b>	<b>97.2°</b>	<b>97.2°</b>	<b>97.2°</b>	<b>97.2°</b>	<b>97.4°</b>	<b>97.4°</b>	<b>97.4°</b>	<b>97.4°</b>
Clearance at maximum lift/level bucket	<b>mm</b> <b>in</b>	2902 <b>114.3</b>	2904 <b>114.3</b>	2889 <b>113.7</b>	2902 <b>114.3</b>	2908 <b>114.5</b>	2893 <b>113.9</b>	2908 <b>114.5</b>	2892 <b>113.9</b>
Hinge pin height at maximum lift	<b>mm</b> <b>in</b>	3227 <b>127.0</b>	3227 <b>127.0</b>	3227 <b>127.0</b>	3227 <b>127.0</b>	3227 <b>127.0</b>	3227 <b>127.0</b>	3227 <b>127.0</b>	3227 <b>127.0</b>
Maximum overall height	<b>mm</b> <b>in</b>	4116 <b>162.0</b>	4018 <b>158.2</b>	4046 <b>159.3</b>	4116 <b>162.0</b>	3965 <b>156.1</b>	3992 <b>157.2</b>	3965 <b>156.1</b>	3992 <b>157.2</b>
Reach at level lift arm/bucket	<b>mm</b> <b>in</b>	1518 <b>59.8</b>	1420 <b>55.9</b>	1449 <b>57.0</b>	1518 <b>59.8</b>	1356 <b>53.4</b>	1385 <b>54.5</b>	1357 <b>53.4</b>	1386 <b>54.6</b>
Maximum floor angle at minimum lift	<b>degrees</b>	<b>27.3°</b>	<b>27.3°</b>	<b>27.3°</b>	<b>27.3°</b>	<b>28°</b>	<b>28°</b>	<b>28°</b>	<b>28°</b>
Dig depth with level bucket	<b>mm</b> <b>in</b>	1 <b>0.04</b>	0 <b>0</b>	16 <b>0.63</b>	1 <b>0.04</b>	0 <b>0</b>	16 <b>0.63</b>	0 <b>0</b>	16 <b>0.63</b>
Overall length with bucket on ground	<b>mm</b> <b>in</b>	3670 <b>144.5</b>	3572 <b>140.6</b>	3600 <b>141.7</b>	3670 <b>144.5</b>	3515 <b>138.4</b>	3543 <b>139.5</b>	3515 <b>138.4</b>	3543 <b>139.5</b>
Front clearance circle radius (with bucket)	<b>mm</b> <b>in</b>	2200 <b>86.6</b>	2168 <b>85.4</b>	2200 <b>86.6</b>	2229 <b>87.8</b>	2067 <b>81.4</b>	2094 <b>82.4</b>	2097 <b>82.6</b>	2125 <b>83.7</b>
Tipping load	<b>kg</b> <b>lb</b>	1525 <b>3363</b>	1526 <b>3365</b>	1470 <b>3241</b>	1506 <b>3321</b>	1811 <b>3993</b>	1754 <b>3868</b>	1787 <b>3940</b>	1727 <b>3808</b>
Breakout force — lift	<b>kg</b> <b>lb</b>	1902 <b>4194</b>	1903 <b>4196</b>	1847 <b>4073</b>	1888 <b>4163</b>	2132 <b>4701</b>	2078 <b>4582</b>	2112 <b>4657</b>	2055 <b>4531</b>
Breakout force — tilt	<b>kg</b> <b>lb</b>	2210 <b>4873</b>	2217 <b>4888</b>	2097 <b>4624</b>	2204 <b>4860</b>	2497 <b>5506</b>	2361 <b>5206</b>	2487 <b>5484</b>	2349 <b>5180</b>
Operating weight	<b>kg</b> <b>lb</b>	3377 <b>7446</b>	3379 <b>7451</b>	3415 <b>7530</b>	3396 <b>7488</b>	3153 <b>6952</b>	3183 <b>7019</b>	3178 <b>7007</b>	3211 <b>7080</b>



<b>Work Tool</b>		<b>Pallet Fork</b>		
		<b>910 mm (36")</b>	<b>1070 mm (42")</b>	<b>1220 mm (48")</b>
<b>Tine Length</b>		<b>910 mm (36")</b>	<b>1070 mm (42")</b>	<b>1220 mm (48")</b>
<b>Tire Size</b>		<b>12 x 16.5</b>	<b>12 x 16.5</b>	<b>12 x 16.5</b>
<b>Carriage Assembly No.</b>		<b>242-9998</b>	<b>242-9999</b>	<b>243-0000</b>
Carriage overall width without step	<b>mm</b>	1157	1157	1157
	<b>in</b>	<b>45</b>	<b>45</b>	<b>45</b>
Carriage step additional width	<b>mm</b>	108	108	108
	<b>in</b>	<b>4.25</b>	<b>4.25</b>	<b>4.25</b>
Carriage height above blade top	<b>mm</b>	923.5	923.5	923.5
	<b>in</b>	<b>36.4</b>	<b>36.4</b>	<b>36.4</b>
Blade surface height at maximum height	<b>mm</b>	2969	2969	2969
	<b>in</b>	<b>116</b>	<b>116</b>	<b>116</b>
Shank front face reach at maximum height	<b>mm</b>	271	271	271
	<b>in</b>	<b>10.7</b>	<b>10.7</b>	<b>10.7</b>
Blade surface height at level lift arms	<b>mm</b>	1494	1494	1494
	<b>in</b>	<b>58</b>	<b>58</b>	<b>58</b>
Shank front face reach at level lift arms	<b>mm</b>	762	762	762
	<b>in</b>	<b>30</b>	<b>30</b>	<b>30</b>
Blade surface height at minimum lift	<b>mm</b>	71	71	71
	<b>in</b>	<b>2.8</b>	<b>2.8</b>	<b>2.8</b>
Shank front face reach at minimum lift	<b>mm</b>	339	339	339
	<b>in</b>	<b>13</b>	<b>13</b>	<b>13</b>
Overall length at minimum lift, level tine	<b>mm</b>	3884	4044	4194
	<b>in</b>	<b>152.9</b>	<b>159.2</b>	<b>165.1</b>
Tipping load	<b>kg</b>	1343	1272	1211
	<b>lb</b>	<b>2961</b>	<b>2805</b>	<b>2670</b>
Operating weight	<b>kg</b>	3194	3204	3214
	<b>lb</b>	<b>7043</b>	<b>7065</b>	<b>7087</b>

Bucket Type			General Purpose								
Bucket Width Tire Size			1520 mm (60") 12 x 16.5			1680 mm (66") 12 x 16.5			1830 mm (72") 12 x 16.5		
Ground Engaging Type			Holes Only	Bolt-on Edge	Bolt-on Teeth	Holes Only	Bolt-on Edge	Bolt-on Teeth	Holes Only	Bolt-on Edge	Bolt-on Teeth
Bucket Assembly No.			165-6152	152-0224	152-0223	165-6153	152-0226	152-0225	165-6154	152-0229	152-0228
Rated bucket capacity	m <sup>3</sup>	0.36	0.37	0.36	0.40	0.40	0.41	0.44	0.44	0.45	
	yd <sup>3</sup>	0.47	0.48	0.47	0.52	0.52	0.53	0.57	0.57	0.59	
Struck capacity	m <sup>3</sup>	0.26	0.27	0.26	0.29	0.29	0.29	0.32	0.32	0.32	
	yd <sup>3</sup>	0.34	0.35	0.34	0.38	0.38	0.38	0.42	0.42	0.42	
Width	mm	1576	1586	1576	1730	1740	1730	1883	1893	1883	
	in	62	62	62	68	68	68	74	75	74	
Dump clearance at maximum lift/dump	mm	2240	2209	2168	2240	2209	2166	2240	2209	2166	
	in	88	87	85	88	87	85	88	87	85	
Reach at maximum lift/dump	mm	759	766	822	759	766	822	759	766	822	
	in	30	30	32	30	30	32	30	30	32	
Floor angle at maximum lift/dump	degrees	49.5°	49.5°	49.5°	49.5°	49.5°	49.5°	49.5°	49.5°	49.5°	
Floor angle at maximum lift/rack back	degrees	86.9°	86.9°	86.9°	86.9°	86.9°	86.9°	86.9°	86.9°	86.9°	
Clearance at maximum lift/level bucket	mm	2851	2835	2850	2851	2835	2850	2851	2835	2850	
	in	112	112	112	112	112	112	112	112	112	
Hinge pin height at maximum lift	mm	3046	3046	3046	3046	3046	3046	3046	3046	3046	
	in	120	120	120	120	120	120	120	120	120	
Maximum overall height	mm	3927	3954	4024	3927	3954	4024	3927	3954	4024	
	in	155	156	158	155	156	158	155	156	158	
Reach at level lift arm/bucket	mm	1356	1384	1453	1356	1384	1453	1356	1384	1453	
	in	53	54	57	53	54	57	53	54	57	
Maximum floor angle at minimum lift	degrees	25.4°	25.4°	25.4°	25.4°	25.4°	25.4°	25.4°	25.4°	25.4°	
Dig depth with level bucket	mm	4	21	5	4	21	5	4	21	5	
	in	0.2	0.8	0.2	0.2	0.8	0.2	0.2	0.8	0.2	
Overall length with bucket on ground	mm	3490	3518	3588	3490	3518	3588	3490	3518	3588	
	in	137	139	141	137	139	141	137	139	141	
Front clearance circle radius (with bucket)	mm	2192	2224	2259	2221	2253	2286	2252	2283	2313	
	in	86	88	89	87	89	90	89	90	91	
Tipping load	242B2	kg	1843	1782	1815	1822	1764	1800	1814	1752	1792
		lb	4062	3928	4001	4017	3888	3968	4000	3862	3950
	242B2 HF	kg	1904	1843	1876	1884	1824	1861	1875	1812	1853
		lb	4197	4062	4137	4152	4022	4103	4135	3996	4085
Breakout force — lift	242B2	kg	1662	1614	1646	1649	1599	1633	1642	1590	1627
		lb	3665	3558	3628	3635	3525	3600	3621	3505	3586
	242B2 HF	kg	1652	1604	1636	1639	1589	1623	1633	1580	1617
		lb	3643	3537	3607	3614	3503	3578	3599	3484	3564
Breakout force — tilt	242B2	kg	1699	1595	1680	1693	1590	1676	1689	1583	1672
		lb	3745	3517	3704	3733	3504	3695	3723	3491	3687
	242B2 HF	kg	1699	1595	1680	1693	1590	1676	1689	1583	1672
		lb	3745	3517	3704	3733	3504	3695	3723	3491	3687
Operating weight	242B2	kg	3170	3200	3186	3187	3220	3203	3194	3230	3211
		lb	6988	7054	7024	7025	7098	7061	7042	7121	7078
	242B2 HF	kg	3225	3254	3241	3241	3274	3258	3249	3285	3265
		lb	7109	7175	7145	7146	7218	7182	7163	7241	7199

HF = High Flow

Bucket Type	Multi-Purpose										
	1520 mm (60") 12 x 16.5			1680 mm (66") 12 x 16.5			1830 mm (72") 12 x 16.5				
Bucket Width Tire Size											
Ground Engaging Type	Holes Only	Bolt-on Edge	Bolt-on Teeth	Holes Only	Bolt-on Edge	Bolt-on Teeth	Holes Only	Bolt-on Edge	Bolt-on Teeth		
Bucket Assembly No.	154-5004	154-5045	154-5046	154-5008	154-5047	154-5048	154-5010	154-5049	154-5050		
Rated bucket capacity	m <sup>3</sup> yd <sup>3</sup>	0.30 0.39	0.31 0.41	0.30 0.39	0.33 0.43	0.33 0.43	0.34 0.44	0.37 0.48	0.37 0.48	0.37 0.48	
Struck capacity	m <sup>3</sup> yd <sup>3</sup>	0.22 0.29	0.22 0.29	0.22 0.29	0.24 0.31	0.25 0.33	0.24 0.31	0.27 0.35	0.28 0.36	0.27 0.35	
Width	mm in	1595 63	1595 63	1595 63	1749 69	1749 69	1749 69	1902 75	1902 75	1902 75	
Dump clearance at maximum lift/dump	mm in	2238 88	2207 87	2163 85	2238 88	2207 87	2163 85	2238 88	2207 87	2163 85	
Reach at maximum lift/dump	mm in	762 30	769 30	825 32	762 30	769 30	825 32	762 30	769 30	825 32	
Floor angle at maximum lift/dump	degrees	49.6°	49.6°	49.6°	49.6°	49.6°	49.6°	49.6°	49.6°	49.6°	
Floor angle at maximum lift/rack back	degrees	86.8°	86.8°	86.8°	86.8°	86.8°	86.8°	86.8°	86.8°	86.8°	
Clearance at maximum lift/level bucket	mm in	2854 112	2838 112	2853 112	2854 112	2838 112	2853 112	2854 112	2838 112	2853 112	
Hinge pin height at maximum lift	mm in	3046 120	3046 120	3046 120	3046 120	3046 120	3046 120	3046 120	3046 120	3046 120	
Maximum overall height	mm in	3931 155	3958 156	4028 159	3931 155	3958 156	4028 159	3931 155	3958 156	4028 159	
Reach at level lift arm/bucket	mm in	1360 54	1387 55	1457 57	1360 54	1387 55	1457 57	1360 54	1387 55	1457 57	
Maximum floor angle at minimum lift	degrees	25.3°	25.3°	25.3°	25.3°	25.3°	25.3°	25.3°	25.3°	25.3°	
Dig depth with level bucket	mm in	3 0.1	19 0.7	4 0.2	3 0.1	19 0.7	4 0.2	3 0.1	19 0.7	4 0.2	
Overall length with bucket on ground	mm in	3494 138	3522 139	3591 141	3494 138	3522 139	3591 141	3494 138	3522 139	3591 141	
Front clearance circle radius (with bucket)	mm in	2182 86	2214 87	2249 89	2211 87	2243 88	2276 90	2242 88	2273 89	2303 91	
Tipping load	242B2	kg lb	1694 3735	1647 3630	1679 3702	1673 3689	1617 3565	1653 3645	1655 3649	1596 3518	1635 3605
	242B2 HF	kg lb	1754 3868	1707 3762	1740 3835	1734 3822	1677 3697	1714 3778	1716 3782	1656 3650	1695 3737
Breakout force — lift	242B2	kg lb	1552 3422	1508 3324	1538 3390	1536 3386	1487 3278	1520 3351	1521 3353	1470 3240	1505 3318
	242B2 HF	kg lb	1543 3401	1498 3302	1528 3369	1526 3365	1477 3257	1510 3329	1511 3331	1460 3218	1495 3297
Breakout force — tilt	242B2	kg lb	1631 3595	1539 3392	1619 3569	1618 3566	1517 3344	1600 3527	1609 3547	1508 3325	1594 3513
	242B2 HF	kg lb	1631 3595	1539 3392	1619 3569	1618 3566	1517 3344	1600 3527	1609 3547	1508 3325	1594 3513
Operating weight	242B2	kg lb	3301 7277	3331 7344	3317 7314	3320 7318	3352 7391	3336 7354	3338 7359	3374 7439	3355 7396
	242B2 HF	kg lb	3356 7398	3386 7464	3372 7434	3374 7439	3407 7511	3390 7475	3393 7479	3429 7559	3409 7516

HF = High Flow

Bucket Type			Dirt					
			1520 mm (60") 12 x 16.5		1680 mm (66") 12 x 16.5		1830 mm (72") 12 x 16.5	
Bucket Width Tire Size								
Ground Engaging Type			Holes Only	Bolt-on Edge	Holes Only	Bolt-on Edge	Holes Only	Bolt-on Edge
Bucket Assembly No.			165-6156	152-0231	165-6157	152-0232	188-3526	188-2719
Rated bucket capacity	m <sup>3</sup>	0.34	0.35	0.37	0.38	0.41	0.42	
	yd <sup>3</sup>	<b>0.44</b>	<b>0.46</b>	<b>0.48</b>	<b>0.49</b>	<b>0.54</b>	<b>0.55</b>	
Struck capacity	m <sup>3</sup>	0.25	0.25	0.27	0.27	0.29	0.31	
	yd <sup>3</sup>	<b>0.33</b>	<b>0.33</b>	<b>0.35</b>	<b>0.35</b>	<b>0.38</b>	<b>0.41</b>	
Width	mm	1576	1586	1730	1740	1883	1893	
	in	<b>62</b>	<b>62</b>	<b>68</b>	<b>69</b>	<b>74</b>	<b>75</b>	
Dump clearance at maximum lift/dump	mm	2281	2249	2281	2249	2281	2249	
	in	<b>90</b>	<b>89</b>	<b>90</b>	<b>89</b>	<b>90</b>	<b>89</b>	
Reach at maximum lift/dump	mm	724	732	724	732	724	732	
	in	<b>29</b>	<b>29</b>	<b>29</b>	<b>29</b>	<b>29</b>	<b>29</b>	
Floor angle at maximum lift/dump	degrees	49.5°	49.5°	49.5°	49.5°	49.5°	49.5°	
Floor angle at maximum lift/rack back	degrees	86.9°	86.9°	86.9°	86.9°	86.9°	86.9°	
Clearance at maximum lift/level bucket	mm	2851	2835	2851	2835	2851	2835	
	in	<b>112</b>	<b>112</b>	<b>112</b>	<b>112</b>	<b>112</b>	<b>112</b>	
Hinge pin height at maximum lift	mm	3046	3046	3046	3046	3046	3046	
	in	<b>120</b>	<b>120</b>	<b>120</b>	<b>120</b>	<b>120</b>	<b>120</b>	
Maximum overall height	mm	3874	3901	3874	3901	3874	3901	
	in	<b>153</b>	<b>154</b>	<b>153</b>	<b>154</b>	<b>153</b>	<b>154</b>	
Reach at level lift arm/bucket	mm	1302	1330	1302	1330	1302	1330	
	in	<b>51</b>	<b>52</b>	<b>51</b>	<b>52</b>	<b>51</b>	<b>52</b>	
Maximum floor angle at minimum lift	degrees	25.4°	25.4°	25.4°	25.4°	25.4°	25.4°	
Dig depth with level bucket	mm	4	20	4	20	4	20	
	in	<b>0.2</b>	<b>0.8</b>	<b>0.2</b>	<b>0.8</b>	<b>0.2</b>	<b>0.8</b>	
Overall length with bucket on ground	mm	3437	3465	3437	3465	3437	3465	
	in	<b>135</b>	<b>136</b>	<b>135</b>	<b>136</b>	<b>135</b>	<b>136</b>	
Front clearance circle radius (with bucket)	mm	2137	2169	2154	2185	2198	2229	
	in	<b>84</b>	<b>85</b>	<b>85</b>	<b>86</b>	<b>87</b>	<b>88</b>	
Tipping load	242B2	kg	1949	1889	1926	1862	1918	1850
		lb	<b>4297</b>	<b>4165</b>	<b>4246</b>	<b>4104</b>	<b>4229</b>	<b>4079</b>
	242B2 HF	kg	2012	1951	1989	1924	1981	1912
		lb	<b>4435</b>	<b>4302</b>	<b>4384</b>	<b>4241</b>	<b>4367</b>	<b>4216</b>
Breakout force — lift	242B2	kg	1741	1692	1721	1669	1714	1660
		lb	<b>3838</b>	<b>3731</b>	<b>3793</b>	<b>3680</b>	<b>3779</b>	<b>3660</b>
	242B2 HF	kg	1731	1682	1711	1660	1704	1650
		lb	<b>3816</b>	<b>3709</b>	<b>3771</b>	<b>3659</b>	<b>3757</b>	<b>3638</b>
Breakout force — tilt	242B2	kg	1852	1739	1841	1726	1838	1720
		lb	<b>4083</b>	<b>3833</b>	<b>4060</b>	<b>3806</b>	<b>4051</b>	<b>3791</b>
	242B2 HF	kg	1852	1739	1841	1726	1838	1720
		lb	<b>4083</b>	<b>3833</b>	<b>4060</b>	<b>3806</b>	<b>4051</b>	<b>3791</b>
Operating weight	242B2	kg	3111	3141	3136	3169	3144	3180
		lb	<b>6859</b>	<b>6925</b>	<b>6915</b>	<b>6987</b>	<b>6932</b>	<b>7011</b>
	242B2 HF	kg	3166	3196	3191	3224	3199	3235
		lb	<b>6980</b>	<b>7046</b>	<b>7035</b>	<b>7107</b>	<b>7052</b>	<b>7131</b>

HF = High Flow

<b>Work Tool</b>		<b>Pallet Fork</b>			
		<b>910 mm (36")</b>	<b>1070 mm (42")</b>	<b>1220 mm (48")</b>	
<b>Tine Length</b>		<b>910 mm (36")</b>	<b>1070 mm (42")</b>	<b>1220 mm (48")</b>	
<b>Tire Size</b>		<b>12 x 16.5</b>	<b>12 x 16.5</b>	<b>12 x 16.5</b>	
<b>Carriage Assembly No.</b>		<b>242-9998</b>	<b>242-9999</b>	<b>243-0000</b>	
Carriage overall width without step	<b>mm</b>	1157	1157	1157	
	<b>in</b>	<b>45</b>	<b>45</b>	<b>45</b>	
Carriage step additional width	<b>mm</b>	108	108	108	
	<b>in</b>	<b>4.25</b>	<b>4.25</b>	<b>4.25</b>	
Carriage height above blade top	<b>mm</b>	924	924	924	
	<b>in</b>	<b>36.4</b>	<b>36.4</b>	<b>36.4</b>	
Blade surface height at maximum height	<b>mm</b>	2931	2931	2931	
	<b>in</b>	<b>115.4</b>	<b>115.4</b>	<b>115.4</b>	
Shank front face reach at maximum height	<b>mm</b>	624	624	624	
	<b>in</b>	<b>24.6</b>	<b>24.6</b>	<b>24.6</b>	
Blade surface height at level lift arms	<b>mm</b>	1526	1526	1526	
	<b>in</b>	<b>60.1</b>	<b>60.1</b>	<b>60.1</b>	
Shank front face reach at level lift arms	<b>mm</b>	762	762	762	
	<b>in</b>	<b>30.0</b>	<b>30.0</b>	<b>30.0</b>	
Blade surface height at minimum lift	<b>mm</b>	76	76	76	
	<b>in</b>	<b>3.0</b>	<b>3.0</b>	<b>3.0</b>	
Shank front face reach at minimum lift	<b>mm</b>	468	468	468	
	<b>in</b>	<b>18.4</b>	<b>18.4</b>	<b>18.4</b>	
Overall length at minimum lift, level tine	<b>mm</b>	3806	3966	4116	
	<b>in</b>	<b>149.8</b>	<b>156.1</b>	<b>162.0</b>	
Tipping load	<b>242B2</b>	<b>kg</b>	1432	1354	1286
		<b>lb</b>	<b>3158</b>	<b>2985</b>	<b>2835</b>
	<b>242B2 HF</b>	<b>kg</b>	1481	1400	1330
		<b>lb</b>	<b>3264</b>	<b>3086</b>	<b>2932</b>
Operating weight	<b>242B2</b>	<b>kg</b>	3152	3163	3172
		<b>lb</b>	<b>6950</b>	<b>6973</b>	<b>6994</b>
	<b>242B2 HF</b>	<b>kg</b>	3207	3217	3227
		<b>lb</b>	<b>7070</b>	<b>7093</b>	<b>7114</b>

HF = High Flow

Bucket Type	General Purpose						Multi-Purpose		
	1680 mm (66") 12 x 16.5			1830 mm (72") 12 x 16.5			1680 mm (66") 12 x 16.5		
Bucket Width Tire Size	Holes Only	Bolt-on Edge	Bolt-on Teeth	Holes Only	Bolt-on Edge	Bolt-on Teeth	Holes Only	Bolt-on Edge	
Ground Engaging Type									
Bucket Assembly No.	165-6153	152-0226	152-0225	165-6154	152-0229	152-0228	154-5008	154-5047	
Rated bucket capacity	m <sup>3</sup> yd <sup>3</sup>	0.40 0.52	0.40 0.52	0.41 0.53	0.44 0.57	0.44 0.57	0.45 0.59	0.33 0.43	0.33 0.43
Struck capacity	m <sup>3</sup> yd <sup>3</sup>	0.29 0.38	0.29 0.38	0.29 0.38	0.32 0.42	0.32 0.42	0.32 0.42	0.24 0.31	0.25 0.33
Width	mm in	1730 68	1740 68	1730 68	1883 74	1893 75	1883 74	1749 69	1749 69
Dump clearance at maximum lift/dump	mm in	2439 96.0	2394 94.3	2318 91.3	2439 96.0	2394 94.3	2318 91.3	2435 95.9	2392 94.2
Reach at maximum lift/dump	mm in	769 30.3	780 30.7	841 33.1	769 30.3	780 30.7	841 33.1	773 30.4	784 30.9
Floor angle at maximum lift/dump	degrees	51°	51°	51°	51°	51°	51°	51°	51°
Floor angle at maximum lift/rack back	degrees	87°	87°	87°	87°	87°	87°	87°	87°
Clearance at maximum lift/level bucket	mm in	3039 119.6	3032 119.4	3031 119.3	3039 119.6	3032 119.4	3031 119.3	3039 119.6	3032 119.4
Hinge pin height at maximum lift	mm in	3227 127	3227 127	3227 127	3227 127	3227 127	3227 127	3227 127	3227 127
Maximum overall height	mm in	4091 161.1	4131 162.6	4229 166.5	4091 161.1	4131 162.6	4229 166.5	4096 161.3	4135 162.8
Reach at level lift arm/bucket	mm in	1290 50.8	1331 52.4	1429 56.3	1290 50.8	1331 52.4	1429 56.3	1295 51	1335 52.3
Maximum floor angle at minimum lift	degrees	27°	27°	27°	27°	27°	27°	27°	27°
Dig depth with level bucket	mm in	0 0	16 0.63	1 0.04	0 0	16 0.63	1 0.04	0 0	16 0.63
Overall length with bucket on ground	mm in	3628 142.8	3669 144.4	3767 148.3	3628 142.8	3669 144.4	3767 148.3	3633 143	3673 144.6
Front clearance circle radius (with bucket)	mm in	2187 86.1	2234 88	2298 90.5	2217 87.3	2264 89.1	2325 91.5	2191 86.3	2236 88
Tipping load	kg lb	2370 5226	2305 5083	2350 5182	2364 5213	2299 5069	2342 5164	2217 4888	2158 4758
Breakout force — lift	kg lb	2303 5078	2247 4955	2287 5043	2296 5063	2238 4935	2280 5027	2187 4822	2133 4703
Breakout force — tilt	kg lb	2317 5109	2189 4827	2299 5069	2312 5098	2183 4814	2296 5063	2233 4924	2110 4653
Operating weight	kg lb	3603 7945	3635 8015	3619 7980	3610 7960	3646 8039	3627 7998	3735 8236	3768 8308

Bucket Type	Multi-Purpose					Dirt			
Bucket Width	1680 mm (66")	1830 mm (72")			1520 mm (60")		1680 mm (66")		
Tire Size	12 x 16.5	12 x 16.5			12 x 16.5		12 x 16.5		
Ground Engaging Type	Bolt-on Teeth	Holes Only	Bolt-on Edge	Bolt-on Teeth	Holes Only	Bolt-on Edge	Holes Only	Bolt-on Edge	
Bucket Assembly No.	154-5048	154-5010	154-5049	154-5050	165-6156	152-0231	165-6157	152-0232	
Rated bucket capacity	<b>m<sup>3</sup></b> <b>yd<sup>3</sup></b>	0.34 <b>0.44</b>	0.37 <b>0.48</b>	0.37 <b>0.48</b>	0.37 <b>0.48</b>	0.34 <b>0.44</b>	0.35 <b>0.46</b>	0.37 <b>0.48</b>	0.38 <b>0.49</b>
Struck capacity	<b>m<sup>3</sup></b> <b>yd<sup>3</sup></b>	0.24 <b>0.31</b>	0.27 <b>0.35</b>	0.28 <b>0.36</b>	0.27 <b>0.35</b>	0.25 <b>0.33</b>	0.25 <b>0.33</b>	0.27 <b>0.35</b>	0.27 <b>0.35</b>
Width	<b>mm</b> <b>in</b>	1749 <b>69</b>	1902 <b>75</b>	1902 <b>75</b>	1902 <b>75</b>	1576 <b>62</b>	1586 <b>62</b>	1730 <b>68</b>	1740 <b>69</b>
Dump clearance at maximum lift/dump	<b>mm</b> <b>in</b>	2316 <b>91.2</b>	2435 <b>95.9</b>	2392 <b>94.2</b>	2316 <b>91.2</b>	2435 <b>95.9</b>	2403 <b>94.6</b>	2435 <b>95.9</b>	2403 <b>94.6</b>
Reach at maximum lift/dump	<b>mm</b> <b>in</b>	845 <b>33.3</b>	773 <b>30.4</b>	784 <b>30.9</b>	845 <b>33.3</b>	746 <b>29.4</b>	752 <b>29.6</b>	746 <b>29.4</b>	752 <b>29.6</b>
Floor angle at maximum lift/dump	<b>degrees</b>	<b>51°</b>	<b>51°</b>	<b>51°</b>	<b>51°</b>	<b>51°</b>	<b>51°</b>	<b>51°</b>	<b>51°</b>
Floor angle at maximum lift/rack back	<b>degrees</b>	<b>87°</b>	<b>87°</b>	<b>87°</b>	<b>87°</b>	<b>87°</b>	<b>87°</b>	<b>87°</b>	<b>87°</b>
Clearance at maximum lift/level bucket	<b>mm</b> <b>in</b>	3031 <b>119.3</b>	3039 <b>119.6</b>	3032 <b>119.4</b>	3031 <b>119.3</b>	3039 <b>119.6</b>	3032 <b>119.4</b>	3039 <b>119.6</b>	3032 <b>119.4</b>
Hinge pin height at maximum lift	<b>mm</b> <b>in</b>	3227 <b>127</b>	3227 <b>127</b>	3227 <b>127</b>	3227 <b>127</b>	3227 <b>127</b>	3227 <b>127</b>	3227 <b>127</b>	3227 <b>127</b>
Maximum overall height	<b>mm</b> <b>in</b>	4232 <b>166.6</b>	4096 <b>161.3</b>	4136 <b>162.8</b>	4232 <b>166.6</b>	4078 <b>160.6</b>	4105 <b>161.6</b>	4078 <b>160.6</b>	4105 <b>161.6</b>
Reach at level lift arm/bucket	<b>mm</b> <b>in</b>	1433 <b>56.4</b>	1295 <b>51</b>	1335 <b>52.3</b>	1433 <b>56.4</b>	1630 <b>64.2</b>	1587 <b>65.5</b>	1603 <b>64.2</b>	1587 <b>65.5</b>
Maximum floor angle at minimum lift	<b>degrees</b>	<b>27°</b>	<b>27°</b>	<b>27°</b>	<b>27°</b>	<b>27°</b>	<b>27°</b>	<b>27°</b>	<b>27°</b>
Dig depth with level bucket	<b>mm</b> <b>in</b>	1 <b>0.04</b>	0 <b>0</b>	16 <b>0.63</b>	1 <b>0.04</b>	0 <b>0</b>	16 <b>0.63</b>	0 <b>0</b>	16 <b>0.63</b>
Overall length with bucket on ground	<b>mm</b> <b>in</b>	3771 <b>148.5</b>	3633 <b>143</b>	3673 <b>144.6</b>	3771 <b>148.5</b>	3616 <b>142.4</b>	3644 <b>143.5</b>	3616 <b>142.4</b>	3644 <b>143.5</b>
Front clearance circle radius (with bucket)	<b>mm</b> <b>in</b>	2301 <b>90.6</b>	2222 <b>87.5</b>	2267 <b>89.3</b>	2328 <b>91.7</b>	2161 <b>85.1</b>	2193 <b>86.3</b>	2190 <b>86.2</b>	2222 <b>87.5</b>
Tipping load	<b>kg</b> <b>lb</b>	2198 <b>4847</b>	2199 <b>4849</b>	2137 <b>4712</b>	2179 <b>4805</b>	2510 <b>5535</b>	2446 <b>5393</b>	2487 <b>5484</b>	2419 <b>5334</b>
Breakout force — lift	<b>kg</b> <b>lb</b>	2171 <b>4787</b>	2172 <b>4789</b>	2115 <b>4664</b>	2156 <b>4754</b>	2404 <b>5301</b>	2349 <b>5180</b>	2383 <b>5255</b>	2326 <b>5129</b>
Breakout force — tilt	<b>kg</b> <b>lb</b>	2216 <b>4886</b>	2225 <b>4906</b>	2101 <b>4633</b>	2209 <b>4871</b>	2515 <b>5546</b>	2375 <b>5237</b>	2504 <b>5521</b>	2362 <b>5208</b>
Operating weight	<b>kg</b> <b>lb</b>	3751 <b>8271</b>	3753 <b>8275</b>	3790 <b>8357</b>	3770 <b>8313</b>	3527 <b>7777</b>	3557 <b>7843</b>	3552 <b>7832</b>	3585 <b>7905</b>

Work Tool		Pallet Fork		
		910 mm (36")	1070 mm (42")	1220 mm (48")
<b>Tine Length</b>		<b>910 mm (36")</b>	<b>1070 mm (42")</b>	<b>1220 mm (48")</b>
<b>Tire Size</b>		<b>12 x 16.5</b>	<b>12 x 16.5</b>	<b>12 x 16.5</b>
<b>Carriage Assembly No.</b>		<b>242-9998</b>	<b>242-9999</b>	<b>243-0000</b>
Carriage overall width without step	<b>mm</b>	1157	1157	1157
	<b>in</b>	<b>45</b>	<b>45</b>	<b>45</b>
Carriage step additional width	<b>mm</b>	108	108	108
	<b>in</b>	<b>4.25</b>	<b>4.25</b>	<b>4.25</b>
Carriage height above blade top	<b>mm</b>	923.5	923.5	923.5
	<b>in</b>	<b>36.4</b>	<b>36.4</b>	<b>36.4</b>
Blade surface height at maximum height	<b>mm</b>	3124	3124	3124
	<b>in</b>	<b>123</b>	<b>123</b>	<b>123</b>
Shank front face reach at maximum height	<b>mm</b>	671	671	671
	<b>in</b>	<b>26.4</b>	<b>26.4</b>	<b>26.4</b>
Blade surface height at level lift arms	<b>mm</b>	1695	1695	1695
	<b>in</b>	<b>66.7</b>	<b>66.7</b>	<b>66.7</b>
Shank front face reach at level lift arms	<b>mm</b>	737	737	737
	<b>in</b>	<b>29</b>	<b>29</b>	<b>29</b>
Blade surface height at minimum lift	<b>mm</b>	79	79	79
	<b>in</b>	<b>3.1</b>	<b>3.1</b>	<b>3.1</b>
Shank front face reach at minimum lift	<b>mm</b>	387	387	387
	<b>in</b>	<b>15.2</b>	<b>15.2</b>	<b>15.2</b>
Overall length at minimum lift, level tine	<b>mm</b>	3985	4145	4295
	<b>in</b>	<b>156.9</b>	<b>163.2</b>	<b>169.1</b>
Tipping load	<b>kg</b>	1885	1787	1703
	<b>lb</b>	<b>4156</b>	<b>3940</b>	<b>3755</b>
Operating weight	<b>kg</b>	3568	3578	3588
	<b>lb</b>	<b>7867</b>	<b>7889</b>	<b>7912</b>



Bucket Type		General Purpose									
Bucket Width Tire Size		1680 mm (66") 12 x 16.5			1830 mm (72") 12 x 16.5			1981 mm (78") 12 x 16.5			
Ground Engaging Type		Holes Only	Bolt-on Edge	Bolt-on Teeth	Holes Only	Bolt-on Edge	Bolt-on Teeth	Holes Only	Bolt-on Edge	Bolt-on Teeth	
Bucket Assembly No.		279-5368	279-5369	279-5370	279-5372	279-5373	279-5374	279-5376	279-5377	279-5378	
Rated bucket capacity	m <sup>3</sup>	0.40	0.41	0.40	0.44	0.45	0.44	0.47	0.49	0.47	
	yd <sup>3</sup>	0.52	0.54	0.52	0.58	0.59	0.58	0.61	0.64	0.61	
Struck capacity	m <sup>3</sup>	0.29	0.29	0.29	0.32	0.32	0.32	0.34	0.34	0.34	
	yd <sup>3</sup>	0.38	0.38	0.38	0.42	0.42	0.42	0.44	0.44	0.44	
Width	mm	1730	1740	1730	1883	1893	1883	2035	2045	2035	
	in	68.1	68.5	68.1	74.1	74.5	74.1	80.1	80.5	80.1	
Dump clearance at maximum lift/dump	mm	2399	2385	2350	2399	2385	2350	2399	2385	2350	
	in	94.4	93.9	92.5	94.4	93.9	92.5	94.4	93.9	92.5	
Reach at maximum lift/dump	mm	627	655	725	627	655	725	627	655	725	
	in	24.7	25.8	28.5	24.7	25.8	28.5	24.7	25.8	28.5	
Floor angle at maximum lift/dump	degrees	40.1°	40.1°	40.1°	40.1°	40.1°	40.1°	40.1°	40.1°	40.1°	
Floor angle at maximum lift/rack back	degrees	94.8°	94.8°	94.8°	94.8°	94.8°	94.8°	94.8°	94.8°	94.8°	
Clearance at maximum lift/level bucket	mm	2928	2912	2928	2928	2912	2928	2928	2912	2928	
	in	115.3	114.6	115.3	115.3	114.6	115.3	115.3	114.6	115.3	
Hinge pin height at maximum lift	mm	3122	3122	3122	3122	3122	3122	3122	3122	3122	
	in	122.9	122.9	122.9	122.9	122.9	122.9	122.9	122.9	122.9	
Maximum overall height	mm	4051	4079	4149	4051	4079	4149	4051	4079	4149	
	in	159.5	160.6	163.3	159.5	160.6	163.3	159.5	160.6	163.3	
Reach at level lift arm/bucket	mm	1441	1469	1441	1441	1469	1441	1441	1469	1441	
	in	56.7	57.8	56.7	56.7	57.8	56.7	56.7	57.8	56.7	
Maximum floor angle at minimum lift	degrees	26.4°	26.4°	26.4°	26.4°	26.4°	26.4°	26.4°	26.4°	26.4°	
Dig depth with level bucket	mm	12	29	12	12	29	12	12	29	12	
	in	0.5	1.1	0.5	0.5	1.1	0.5	0.5	1.1	0.5	
Overall length with bucket on ground	mm	3692	3720	3790	3692	3720	3790	3692	3720	3790	
	in	145.4	146.5	149.2	145.4	146.5	149.2	145.4	146.5	149.2	
Front clearance circle radius (with bucket)	mm	2433	2447	2482	2433	2447	2482	2433	2447	2482	
	in	95.8	96.3	97.7	95.8	96.3	97.7	95.8	96.3	97.7	
Tipping load	246C	kg	1910	1852	1888	1897	1835	1875	1883	1821	1860
		lb	4211	4083	4162	4182	4045	4134	4151	4015	4101
	256C	kg	2013	1955	1991	2000	1938	1978	1986	1923	1963
		lb	4438	4310	4389	4409	4273	4361	4378	4239	4328
Breakout force — lift	246C	kg	2654	2592	2638	2643	2578	2627	2634	2567	2616
		lb	5851	5714	5816	5827	5683	5792	5807	5659	5767
	256C	kg	2654	2592	2638	2643	2578	2627	2634	2567	2616
		lb	5851	5714	5816	5827	5683	5792	5807	5659	5767
Breakout force — tilt	246C	kg	3096	2937	3079	3089	2927	3072	3086	2923	3067
		lb	6825	6475	6788	6810	6453	6773	6803	6444	6762
	256C	kg	3096	2937	3079	3089	2927	3072	3086	2923	3067
		lb	6825	6475	6788	6810	6453	6773	6803	6444	6762
Operating weight	246C	kg	3349	3382	3365	3362	3397	3378	3374	3411	3392
		lb	7383	7456	7419	7412	7489	7447	7438	7520	7478
	256C	kg	3434	3467	3451	3447	3483	3464	3460	3497	3478
		lb	7571	7643	7608	7599	7679	7637	7628	7710	7668

Bucket Type			High Capacity — GP			Multi-Purpose					
Bucket Width Tire Size			2134 mm (84") 12 x 16.5			1680 mm (66") 12 x 16.5			1830 mm (72") 12 x 16.5		
Ground Engaging Type			Holes Only	Bolt-on Edge	Bolt-on Teeth	Holes Only	Bolt-on Edge	Bolt-on Teeth	Holes Only	Bolt-on Edge	Bolt-on Teeth
Bucket Assembly No.			292-9271	296-8192	296-8191	279-5390	279-5391	279-5392	273-5398	273-5399	273-5400
Rated bucket capacity	m <sup>3</sup>	0.63	0.63	0.63	0.33	0.34	0.33	0.37	0.38	0.37	
	yd <sup>3</sup>	<b>0.82</b>	<b>0.82</b>	<b>0.82</b>	<b>0.43</b>	<b>0.44</b>	<b>0.43</b>	<b>0.48</b>	<b>0.50</b>	<b>0.48</b>	
Struck capacity	m <sup>3</sup>	0.59	0.59	0.59	0.24	0.24	0.24	0.26	0.26	0.26	
	yd <sup>3</sup>	<b>0.77</b>	<b>0.77</b>	<b>0.77</b>	<b>0.31</b>	<b>0.31</b>	<b>0.31</b>	<b>0.34</b>	<b>0.34</b>	<b>0.34</b>	
Width	mm	2187	2198	2187	1730	1740	1730	1883	1883	1883	
	in	<b>86.1</b>	<b>86.5</b>	<b>86.1</b>	<b>68.1</b>	<b>68.5</b>	<b>68.1</b>	<b>74.1</b>	<b>74.1</b>	<b>74.1</b>	
Dump clearance at maximum lift/dump	mm	*	*	*	2396	2382	2347	2396	2382	2347	
	in	*	*	*	<b>94.3</b>	<b>93.8</b>	<b>92.4</b>	<b>94.3</b>	<b>93.8</b>	<b>92.4</b>	
Reach at maximum lift/dump	mm	*	*	*	629	643	678	629	643	678	
	in	*	*	*	<b>24.8</b>	<b>25.3</b>	<b>26.7</b>	<b>24.8</b>	<b>25.3</b>	<b>26.7</b>	
Floor angle at maximum lift/dump	degrees	*	*	*	40.1°	40.1°	40.1°	40.1°	40.1°	40.1°	
	degrees	*	*	*	<b>94.8°</b>	<b>94.8°</b>	<b>94.8°</b>	<b>94.8°</b>	<b>94.8°</b>	<b>94.8°</b>	
Clearance at maximum lift/level bucket	mm	*	*	*	2925	2908	2925	2925	2908	2925	
	in	*	*	*	<b>115.2</b>	<b>114.5</b>	<b>115.2</b>	<b>115.2</b>	<b>114.5</b>	<b>115.2</b>	
Hinge pin height at maximum lift	mm	*	*	*	3122	3122	3122	3122	3122	3122	
	in	*	*	*	<b>122.9</b>	<b>122.9</b>	<b>122.9</b>	<b>122.9</b>	<b>122.9</b>	<b>122.9</b>	
Maximum overall height	mm	*	*	*	4055	4083	4153	4055	4083	4153	
	in	*	*	*	<b>159.6</b>	<b>160.7</b>	<b>163.5</b>	<b>159.6</b>	<b>160.7</b>	<b>163.5</b>	
Reach at level lift arm/bucket	mm	*	*	*	1448	1476	1546	1448	1476	1546	
	in	*	*	*	<b>57.0</b>	<b>58.1</b>	<b>60.9</b>	<b>57.0</b>	<b>58.1</b>	<b>60.9</b>	
Maximum floor angle at minimum lift	degrees	26°	26°	26°	26.1°	26.1°	26.1°	26.1°	26.1°	26.1°	
	mm	*	*	*	16	33	16	16	33	16	
Dig depth with level bucket	in	*	*	*	<b>0.6</b>	<b>1.3</b>	<b>0.6</b>	<b>0.6</b>	<b>1.3</b>	<b>0.6</b>	
	mm	*	*	*	3749	3777	3847	3749	3777	3847	
Overall length with bucket on ground	in	*	*	*	<b>147.6</b>	<b>148.7</b>	<b>151.5</b>	<b>147.6</b>	<b>148.7</b>	<b>151.5</b>	
	mm	*	*	*	2466	2480	2202	2466	2480	2202	
Front clearance circle radius (with bucket)	in	*	*	*	<b>97.1</b>	<b>97.6</b>	<b>86.7</b>	<b>97.1</b>	<b>97.6</b>	<b>86.7</b>	
	mm	*	*	*	1831	1766	1877	1759	1704	1740	
Tipping load	kg	<b>4037</b>	<b>3893</b>	<b>4138</b>	<b>3878</b>	<b>3757</b>	<b>3836</b>	<b>3836</b>	<b>3708</b>	<b>3792</b>	
	lb	1931	1865	1907	1861	1805	1842	1842	1783	1822	
Breakout force — lift	kg	<b>4257</b>	<b>4112</b>	<b>4204</b>	<b>4103</b>	<b>3979</b>	<b>4061</b>	<b>4061</b>	<b>3931</b>	<b>4017</b>	
	lb	2518	2450	2501	2539	2477	2523	2523	2459	2507	
Breakout force — tilt	kg	<b>5551</b>	<b>5401</b>	<b>5514</b>	<b>5598</b>	<b>5461</b>	<b>5562</b>	<b>5562</b>	<b>5421</b>	<b>5527</b>	
	lb	2518	2450	2501	2539	2477	2523	2523	2459	2507	
Operating weight	kg	<b>5551</b>	<b>5401</b>	<b>5514</b>	<b>5598</b>	<b>5461</b>	<b>5562</b>	<b>5562</b>	<b>5421</b>	<b>5527</b>	
	lb	2742	2602	2724	3007	2851	2989	2997	2841	2982	
Breakout force — tilt	kg	<b>6045</b>	<b>5732</b>	<b>6005</b>	<b>6629</b>	<b>6285</b>	<b>6590</b>	<b>6607</b>	<b>6263</b>	<b>6574</b>	
	lb	2742	2602	2724	3007	2851	2989	2997	2841	2982	
Operating weight	kg	<b>6045</b>	<b>5732</b>	<b>6005</b>	<b>6629</b>	<b>6285</b>	<b>6590</b>	<b>6607</b>	<b>6263</b>	<b>6574</b>	
	lb	3429	3471	3447	3482	3515	3498	3502	3538	3518	
Operating weight	kg	<b>7560</b>	<b>7652</b>	<b>7599</b>	<b>7676</b>	<b>7749</b>	<b>7712</b>	<b>7721</b>	<b>7800</b>	<b>7756</b>	
	lb	3512	3554	3530	3568	3601	3584	3587	3623	3604	
Operating weight	kg	<b>7742</b>	<b>7835</b>	<b>7782</b>	<b>7866</b>	<b>7939</b>	<b>7901</b>	<b>7908</b>	<b>7987</b>	<b>7945</b>	
	lb	3512	3554	3530	3568	3601	3584	3587	3623	3604	

\*Information not available at time of printing.

Bucket Type		Multi-Purpose					Dirt				
Bucket Width Tire Size		1981 mm (78") 12 x 16.5			1680 mm (66") 12 x 16.5		1830 mm (72") 12 x 16.5		1981 mm (78") 12 x 16.5		
Ground Engaging Type		Holes Only	Bolt-on Edge	Bolt-on Teeth	Holes Only	Bolt-on Edge	Holes Only	Bolt-on Edge	Holes Only	Bolt-on Edge	
Bucket Assembly No.		273-5403	279-5402	279-5401	279-5440	279-5441	285-6089	285-6090	268-4084	268-4083	
Rated bucket capacity	m <sup>3</sup>	0.40	0.42	0.40	0.37	0.38	0.40	0.42	0.44	0.45	
	yd <sup>3</sup>	0.52	0.55	0.52	0.48	0.50	0.52	0.55	0.58	0.59	
Struck capacity	m <sup>3</sup>	0.28	0.28	0.28	0.27	0.27	0.29	0.3	0.32	0.32	
	yd <sup>3</sup>	0.37	0.37	0.37	0.35	0.35	0.38	0.39	0.42	0.42	
Width	mm	2035	2045	2035	1676	1686	1829	1839	1981	1991	
	in	80.1	80.5	80.1	66.0	66.4	72.0	72.4	78.0	78.4	
Dump clearance at maximum lift/dump	mm	2396	2382	2347	2425	2394	2425	2394	2425	2394	
	in	94.3	93.8	92.4	95.5	94.3	95.5	94.3	95.5	94.3	
Reach at maximum lift/dump	mm	629	643	678	600	613	600	613	600	613	
	in	24.8	25.3	26.7	23.6	24.1	23.6	24.1	23.6	24.1	
Floor angle at maximum lift/dump	degrees	40.1°	40.1°	40.1°	39.8°	39.8°	39.8°	39.8°	39.8°	39.8°	
Floor angle at maximum lift/rack back	degrees	94.8°	94.8°	94.8°	95.2°	95.2°	95.2°	95.2°	95.2°	95.2°	
Clearance at maximum lift/level bucket	mm	2925	2908	2925	2930	2914	2930	2914	2930	2914	
	in	115.2	114.5	115.2	115.4	114.7	115.4	114.7	115.4	114.7	
Hinge pin height at maximum lift	mm	3122	3122	3122	3122	3122	3122	3122	3122	3122	
	in	122.9	122.9	122.9	122.9	122.9	122.9	122.9	122.9	122.9	
Maximum overall height	mm	4055	4083	4153	3998	4026	3998	4026	3998	4026	
	in	159.6	160.7	163.5	157.4	158.5	157.4	158.5	157.4	158.5	
Reach at level lift arm/bucket	mm	1448	1476	1546	1388	1416	1388	1416	1388	1416	
	in	57.0	58.1	60.9	54.6	55.7	54.6	55.7	54.6	55.7	
Maximum floor angle at minimum lift	degrees	26.1°	26.1°	26.1°	26.2°	26.2°	26.2°	26.2°	26.2°	26.2°	
Dig depth with level bucket	mm	16	33	16	10	26	10	26	10	26	
	in	0.6	1.3	0.6	0.4	1.0	0.4	1.0	0.4	1.0	
Overall length with bucket on ground	mm	3749	3777	3847	3692	3720	3692	3720	3692	3720	
	in	147.6	148.7	151.5	145.4	146.5	145.4	146.5	145.4	146.5	
Front clearance circle radius (with bucket)	mm	2466	2480	2202	2433	2447	2433	2447	2433	2447	
	in	97.1	97.6	86.7	95.8	96.3	95.8	96.3	95.8	96.3	
Tipping load	246C	kg	1731	1669	1707	1986	1921	1973	1905	1962	1889
		lb	3816	3680	3763	4378	4235	4350	4200	4325	4165
	256C	kg	1833	1770	1809	2091	2026	2079	2009	2067	1994
		lb	4041	3902	3988	4610	4467	4583	4429	4557	4396
Breakout force — lift	246C	kg	2507	2443	2490	2722	2657	2711	2644	2701	2630
		lb	5527	5386	5489	6001	5858	5977	5829	5955	5798
	256C	kg	2507	2443	2490	2722	2657	2711	2644	2701	2630
		lb	5527	5386	5489	6001	5858	5977	5829	5955	5798
Breakout force — tilt	246C	kg	2989	2830	2969	3324	3144	3317	3134	3314	3129
		lb	6590	6239	6545	7328	6931	7313	6909	7306	6898
	256C	kg	2989	2830	2969	3324	3144	3317	3134	3314	3129
		lb	6590	6239	6545	7328	6931	7313	6909	7306	6898
Operating weight	246C	kg	3521	3558	3539	3326	3359	3339	3375	3352	3392
		lb	7762	7844	7802	7333	7405	7361	7441	7390	7478
	256C	kg	3606	3643	3624	3412	3445	3425	3461	3438	3478
		lb	7950	8031	7990	7522	7595	7551	7630	7579	7668

Work Tool			Pallet Fork		
Tine Length			910 mm (36")	1070 mm (42")	1220 mm (48")
Tire Size			12 x 16.5	12 x 16.5	12 x 16.5
Carriage Assembly No.			293-9427	293-9428	293-9429
Carriage overall width without step	mm		1159	1159	1159
	in		45.6	45.6	45.6
Carriage step additional width	mm		106	106	106
	in		4.2	4.2	4.2
Carriage height above blade top	mm		930	930	930
	in		36.6	36.6	36.6
Blade surface height at maximum height	mm		3015	3015	3015
	in		118.7	118.7	118.7
Shank front face reach at maximum height	mm		375	375	375
	in		14.8	14.8	14.8
Blade surface height at level lift arms	mm		1535	1535	1535
	in		60.4	60.4	60.4
Shank front face reach at level lift arms	mm		840	840	840
	in		33.1	33.1	33.1
Blade surface height at minimum lift	mm		90	90	90
	in		3.5	3.5	3.5
Shank front face reach at minimum lift	mm		410	410	410
	in		16.1	16.1	16.1
Overall length at minimum lift, level tine	mm		4065	4065	4065
	in		160.0	160.0	160.0
Tipping load	246C	kg	1527	1450	1382
		lb	3366	3197	3047
	256C	kg	1609	1528	1458
		lb	3547	3369	3214
Operating weight	246C	kg	3169	3179	3188
		lb	6986	7008	7028
	256C	kg	3400	3410	3420
		lb	7496	7518	7540

Bucket Type		General Purpose								
Bucket Width Tire Size		1680 mm (66") 12 x 16.5			1830 mm (72") 12 x 16.5			1981 mm (78") 12 x 16.5		
Ground Engaging Type		Holes Only	Bolt-on Edge	Bolt-on Teeth	Holes Only	Bolt-on Edge	Bolt-on Teeth	Holes Only	Bolt-on Edge	Bolt-on Teeth
Bucket Assembly No.		279-5368	279-5369	279-5370	279-5372	279-5373	279-5374	279-5376	279-5377	279-5378
Rated bucket capacity	m <sup>3</sup> yd <sup>3</sup>	0.37 0.48	0.38 0.50	0.39 0.51	0.40 0.52	0.42 0.55	0.44 0.58	0.44 0.58	0.45 0.59	0.46 0.60
Struck capacity	m <sup>3</sup> yd <sup>3</sup>	0.27 0.35	0.27 0.35	0.27 0.35	0.29 0.38	0.30 0.39	0.31 0.41	0.32 0.42	0.32 0.42	0.32 0.42
Width	mm in	1730 68.1	1740 68.5	1730 68.1	1883 74.1	1893 74.5	1883 74.1	2035 80.1	2045 80.5	2035 80.1
Dump clearance at maximum lift/dump	mm in	2425 95.5	2411 94.9	2376 93.5	2425 95.5	2411 94.9	2376 93.5	2425 95.5	2411 94.9	2376 93.5
Reach at maximum lift/dump	mm in	826 32.5	840 33.1	875 34.4	826 32.5	840 33.1	875 34.4	826 32.5	840 33.1	875 34.4
Floor angle at maximum lift/dump	degrees	39.2°	39.2°	39.2°	39.2°	39.2°	39.2°	39.2°	39.2°	39.2°
Floor angle at maximum lift/rack back	degrees	84.9°	84.9°	84.9°	84.9°	84.9°	84.9°	84.9°	84.9°	84.9°
Clearance at maximum lift/level bucket	mm in	3043 119.8	3043 119.8	3043 119.8	3043 119.8	3043 119.8	3043 119.8	3043 119.8	3043 119.8	3043 119.8
Hinge pin height at maximum lift	mm in	3233 127.3	3233 127.3	3233 127.3	3233 127.3	3233 127.3	3233 127.3	3233 127.3	3233 127.3	3233 127.3
Maximum overall height	mm in	4075 160.4	4089 161.0	4124 162.4	4075 160.4	4089 161.0	4124 162.4	4075 160.4	4089 161.0	4124 162.4
Reach at level lift arm/bucket	mm in	1301 51.2	1329 52.3	1399 55.1	1301 51.2	1329 52.3	1399 55.1	1301 51.2	1329 52.3	1399 55.1
Maximum floor angle at minimum lift	degrees	26.4°	26.4°	26.4°	26.4°	26.4°	26.4°	26.4°	26.4°	26.4°
Dig depth with level bucket	mm in	11 0.4	27 1.1	11 0.4	11 0.4	27 1.1	11 0.4	11 0.4	27 1.1	11 0.4
Overall length with bucket on ground	mm in	3692 145.4	3720 146.5	3790 149.2	3692 145.4	3720 146.5	3790 149.2	3692 145.4	3720 146.5	3790 149.2
Front clearance circle radius (with bucket)	mm in	2485 97.8	2517 99.1	2566 101.0	2518 99.1	2549 100.4	2598 102.3	2552 100.5	2583 101.7	2631 103.6
Tipping load	kg lb	2400 5291	2337 5152	2378 5243	2387 5262	2320 5115	2364 5212	2372 5229	2305 5082	2349 5179
Breakout force — lift	kg lb	2430 5357	2372 5229	2414 5322	2419 5333	2359 5201	2403 5298	2409 5311	2348 5176	2391 5271
Breakout force — tilt	kg lb	3096 6825	2936 6473	3079 6788	3089 6810	2927 6453	3072 6773	3086 6803	2923 6444	3067 6762
Operating weight	kg lb	3619 7978	3652 8051	3635 8014	3632 8007	3667 8084	3648 8042	3645 8036	3682 8117	3663 8076

Bucket Type		High Capacity — GP			Multi-Purpose					
Bucket Width Tire Size		2134 mm (84") 12 x 16.5			1680 mm (66") 12 x 16.5			1830 mm (72") 12 x 16.5		
Ground Engaging Type		Holes Only	Bolt-on Edge	Bolt-on Teeth	Holes Only	Bolt-on Edge	Bolt-on Teeth	Holes Only	Bolt-on Edge	Bolt-on Teeth
Bucket Assembly No.		292-9271	296-8192	296-8191	279-5390	279-5391	279-5392	279-5398	279-5399	279-5400
Rated bucket capacity	m <sup>3</sup> yd <sup>3</sup>	0.63 0.82	0.63 0.82	0.63 0.82	0.33 0.43	0.34 0.44	0.33 0.43	0.37 0.48	0.38 0.50	0.37 0.48
Struck capacity	m <sup>3</sup> yd <sup>3</sup>	0.59 0.77	0.59 0.77	0.59 0.77	0.24 0.31	0.24 0.31	0.24 0.31	0.26 0.34	0.26 0.34	0.26 0.34
Width	mm in	2187 86.1	2198 86.5	2187 86.1	1730 68.1	1740 68.5	1730 68.1	1883 74.1	1893 74.5	1883 74.1
Dump clearance at maximum lift/dump	mm in	* *	* *	* *	2421 95.3	2407 94.8	2372 93.4	2421 95.3	2407 94.8	2372 93.4
Reach at maximum lift/dump	mm in	* *	* *	* *	810 31.9	824 32.4	859 33.8	810 31.9	824 32.4	859 33.8
Floor angle at maximum lift/dump	degrees	* *	* *	* *	40.1° 40.1°	40.1° 40.1°	40.1° 40.1°	40.1° 40.1°	40.1° 40.1°	40.1° 40.1°
Floor angle at maximum lift/rack back	degrees	* *	* *	* *	94.8° 94.8°	94.8° 94.8°	94.8° 94.8°	94.8° 94.8°	94.8° 94.8°	94.8° 94.8°
Clearance at maximum lift/level bucket	mm in	* *	* *	* *	3036 119.5	3015 118.7	3036 119.5	3036 119.5	3015 118.7	3036 119.5
Hinge pin height at maximum lift	mm in	* *	* *	* *	3233 127.3	3233 127.3	3233 127.3	3233 127.3	3233 127.3	3233 127.3
Maximum overall height	mm in	* *	* *	* *	4105 161.6	4130 162.6	4200 165.4	4105 161.6	4130 162.6	4200 165.4
Reach at level lift arm/bucket	mm in	* *	* *	* *	1343 52.9	1357 53.4	1343 52.9	1343 52.9	1357 53.4	1343 52.9
Maximum floor angle at minimum lift	degrees	26° 26°	26° 26°	26° 26°	26.1° 26.1°	26.1° 26.1°	26.1° 26.1°	26.1° 26.1°	26.1° 26.1°	26.1° 26.1°
Dig depth with level bucket	mm in	* *	* *	* *	16 0.6	33 1.3	16 0.6	16 0.6	33 1.3	16 0.6
Overall length with bucket on ground	mm in	* *	* *	* *	3749 147.6	3777 148.7	3847 151.5	3749 147.6	3777 148.7	3847 151.5
Front clearance circle radius (with bucket)	mm in	* *	* *	* *	2518 99.1	2528 99.5	2616 103.0	2515 99.0	2528 99.5	2616 103.0
Tipping load	kg lb	2302 5075	2235 4927	2279 5024	2242 4943	2183 4813	2223 4901	2223 4901	2160 4762	2203 4857
Breakout force — lift	kg lb	2311 5095	2247 4954	2293 5055	2314 5101	2257 4976	2298 5066	2298 5066	2239 4936	2282 5031
Breakout force — tilt	kg lb	2743 6047	2603 5739	2725 6008	3006 6627	2851 6285	2989 6590	2997 6607	2841 6263	2981 6572
Operating weight	kg lb	3681 8115	3723 8207	3699 8155	3753 8274	3785 8344	3769 8309	3772 8316	3808 8395	3789 8353

\*Information not available at time of printing.

Bucket Type		Multi-Purpose			Dirt					
Bucket Width Tire Size		1981 mm (78") 12 x 16.5			1680 mm (66") 12 x 16.5		1830 mm (72") 12 x 16.5		1981 mm (78") 12 x 16.5	
Ground Engaging Type		Holes Only	Bolt-on Edge	Bolt-on Teeth	Holes Only	Bolt-on Edge	Holes Only	Bolt-on Edge	Holes Only	Bolt-on Edge
Bucket Assembly No.		279-5403	279-5402	279-5401	279-5440	279-5441	285-6089	285-6090	268-4084	268-4083
Rated bucket capacity	m <sup>3</sup> yd <sup>3</sup>	0.40 0.52	0.42 0.55	0.40 0.52	0.37 0.48	0.38 0.50	0.40 0.52	0.42 0.55	0.44 0.58	0.45 0.59
Struck capacity	m <sup>3</sup> yd <sup>3</sup>	0.28 0.37	0.28 0.37	0.28 0.37	0.27 0.35	0.27 0.35	0.29 0.38	0.30 0.39	0.32 0.42	0.32 0.42
Width	mm in	2035 80.1	2045 80.5	2035 80.1	1676 66.0	1686 66.4	1829 72.0	1839 72.4	1981 78.0	1991 78.4
Dump clearance at maximum lift/dump	mm in	2421 95.3	2407 94.8	2372 93.4	2450 96.5	2436 95.9	2450 96.5	2436 95.9	2450 96.5	2436 95.9
Reach at maximum lift/dump	mm in	810 31.9	824 32.4	859 33.8	781 30.7	795 31.3	781 30.7	795 31.3	781 30.7	795 31.3
Floor angle at maximum lift/dump	degrees	40.1°	40.1°	40.1°	39.2°	39.2°	39.2°	39.2°	39.2°	39.2°
Floor angle at maximum lift/rack back	degrees	94.8°	94.8°	94.8°	84.9°	84.9°	84.9°	84.9°	84.9°	84.9°
Clearance at maximum lift/level bucket	mm in	3036 119.5	3015 118.7	3036 119.5	3043 119.8	3043 119.8	3043 119.8	3043 119.8	3043 119.8	3043 119.8
Hinge pin height at maximum lift	mm in	3233 127.3	3233 127.3	3233 127.3	3233 127.3	3233 127.3	3233 127.3	3233 127.3	3233 127.3	3233 127.3
Maximum overall height	mm in	4105 161.6	4130 162.6	4200 165.4	4075 160.4	4089 161.0	4075 160.4	4089 161.0	4075 160.4	4089 161.0
Reach at level lift arm/bucket	mm in	1343 52.9	1357 53.4	1343 52.9	1263 49.7	1292 50.9	1263 49.7	1292 50.9	1263 49.7	1292 50.9
Maximum floor angle at minimum lift	degrees	26.1°	26.1°	26.1°	26.4°	26.4°	26.4°	26.4°	26.4°	26.4°
Dig depth with level bucket	mm in	16 0.6	33 1.3	16 0.6	11 0.4	27 1.1	11 0.4	27 1.1	11 0.4	27 1.1
Overall length with bucket on ground	mm in	3749 147.6	3777 148.7	3847 151.5	3692 145.4	3720 146.5	3692 145.4	3720 146.5	3692 145.4	3720 146.5
Front clearance circle radius (with bucket)	mm in	2518 99.1	2528 99.5	2616 103.0	2485 97.8	2517 99.1	2518 99.1	2549 100.4	2552 100.5	2583 101.7
Tipping load	kg lb	2217 4888	2150 4740	2193 4835	2491 5492	2420 5335	2479 5465	2403 5298	2467 5439	2388 5265
Breakout force — lift	kg lb	2282 5031	2222 4899	2264 4991	2490 5489	2431 5359	2478 5463	2417 5329	2467 5439	2388 5265
Breakout force — tilt	kg lb	2988 6587	2830 6239	2969 6545	3324 7328	3144 6931	3317 7313	3134 6909	3314 7306	3129 6898
Operating weight	kg lb	3791 8358	3838 8461	3809 8397	3596 7928	3629 8001	3610 7959	3645 8036	3623 7987	3663 8076

Work Tool	Pallet Fork		
	910 mm (36")	1070 mm (42")	1220 mm (48")
<b>Tine Length</b>	<b>910 mm (36")</b>	<b>1070 mm (42")</b>	<b>1220 mm (48")</b>
<b>Tire Size</b>	<b>12 x 16.5</b>	<b>12 x 16.5</b>	<b>12 x 16.5</b>
<b>Carriage Assembly No.</b>	<b>293-9427</b>	<b>293-9428</b>	<b>293-9429</b>
Carriage overall width without step	mm in	1159 45.6	1159 45.6
Carriage step additional width	mm in	106 4.2	106 4.2
Carriage height above blade top	mm in	930 36.6	930 36.6
Blade surface height at maximum height	mm in	3130 123.2	3130 123.2
Shank front face reach at maximum height	mm in	697 27.4	697 27.4
Blade surface height at level lift arms	mm in	1608 63.3	1608 63.3
Shank front face reach at level lift arms	mm in	738 29.1	738 29.1
Blade surface height at minimum lift	mm in	90 3.5	90 3.5
Shank front face reach at minimum lift	mm in	410 16.1	410 16.1
Overall length at minimum lift, level tine	mm in	4065 160.0	4065 160.0
Tipping load	kg lb	1896 4180	1798 3964
Operating weight	kg lb	3585 7904	3595 7926
			3604 7945



Bucket Type		General Purpose								
Bucket Width Tire Size		1680 mm (66") 12 x 16.5			1830 mm (72") 12 x 16.5			1981 mm (78") 12 x 16.5		
Ground Engaging Type		Holes Only	Bolt-on Edge	Bolt-on Teeth	Holes Only	Bolt-on Edge	Bolt-on Teeth	Holes Only	Bolt-on Edge	Bolt-on Teeth
Bucket Assembly No.		279-5368	279-5369	279-5370	279-5372	279-5373	279-5374	279-5376	279-5377	279-5378
Rated bucket capacity	m <sup>3</sup> yd <sup>3</sup>	0.37 0.48	0.38 0.50	0.39 0.51	0.4 0.52	0.42 0.55	0.44 0.58	0.44 0.58	0.45 0.59	0.46 0.60
Struck capacity	m <sup>3</sup> yd <sup>3</sup>	0.27 0.35	0.27 0.35	0.27 0.35	0.29 0.38	0.31 0.41	0.31 0.41	0.32 0.42	0.32 0.42	0.32 0.42
Width	mm in	1730 68.1	1740 68.5	1730 68.1	1883 74.1	1893 74.5	1883 74.1	2035 80.1	2045 80.5	2035 80.1
Dump clearance at maximum lift/dump	mm in	2487 97.9	2473 97.4	2438 96.0	2487 97.9	2473 97.4	2438 96.0	2487 97.9	2473 97.4	2438 96.0
Reach at maximum lift/dump	mm in	764 30.1	778 30.6	813 32.0	764 30.1	778 30.6	813 32.0	764 30.1	778 30.6	813 32.0
Floor angle at maximum lift/dump	degrees	40°	40°	40°	40°	40°	40°	40°	40°	40°
Floor angle at maximum lift/rack back	degrees	85°	85°	85°	85°	85°	85°	85°	85°	85°
Clearance at maximum lift/level bucket	mm in	3086 121.5	3069 120.8	3086 121.5	3086 121.5	3069 120.8	3086 121.5	3086 121.5	3086 121.5	3086 121.5
Hinge pin height at maximum lift	mm in	3279 129.1	3279 129.1	3279 129.1	3279 129.1	3279 129.1	3279 129.1	3279 129.1	3279 129.1	3279 129.1
Maximum overall height	mm in	4115 162.0	4140 163.0	4200 165.4	4115 162.0	4140 163.0	4200 165.4	4115 162.0	4140 163.0	4200 165.4
Reach at level lift arm/bucket	mm in	1323 52.1	1333 52.5	1323 52.1	1323 52.1	1333 52.5	1323 52.1	1323 52.1	1333 52.5	1323 52.1
Maximum floor angle at minimum lift	degrees	26.4°	26.4°	26.4°	26.4°	26.4°	26.4°	26.4°	26.4°	26.4°
Dig depth with level bucket	mm in	14 0.6	30 1.2	14 0.6	14 0.6	30 1.2	14 0.6	14 0.6	30 1.2	14 0.6
Overall length with bucket on ground	mm in	3833 150.9	3861 152.0	3931 154.8	3833 150.9	3861 152.0	3931 154.8	3833 150.9	3861 152.0	3931 154.8
Front clearance circle radius (with bucket)	mm in	2520 99.2	2541 100.0	2576 101.4	2553 100.5	2574 101.3	2609 102.7	2577 101.5	2610 102.8	2645 104.1
Tipping load	kg lb	2848 6279	2782 6133	2826 6230	2835 6250	2764 6094	2812 6199	2820 6217	2749 6060	2796 6164
Breakout force — lift	kg lb	2296 5062	2241 4941	2280 5027	2285 5038	2227 4910	2269 5002	2275 5015	2216 4885	2257 4976
Breakout force — tilt	kg lb	3096 6825	2936 6473	3079 6788	3089 6810	2927 6453	3072 6773	3086 6803	2923 6444	3067 6762
Operating weight	kg lb	3779 8331	3812 8404	3795 8367	3792 8360	3827 8437	3808 8395	3805 8389	3842 8470	3823 8428

Bucket Type		High Capacity — GP			Multi-Purpose					
Bucket Width Tire Size		2134 mm (84") 12 x 16.5			1680 mm (66") 12 x 16.5			1830 mm (72") 12 x 16.5		
Ground Engaging Type		Holes Only	Bolt-on Edge	Bolt-on Teeth	Holes Only	Bolt-on Edge	Bolt-on Teeth	Holes Only	Bolt-on Edge	Bolt-on Teeth
Bucket Assembly No.		292-9271	296-8192	296-8191	279-5390	279-5391	279-5392	279-5398	279-5399	279-5400
Rated bucket capacity	m <sup>3</sup> yd <sup>3</sup>	0.63 0.82	0.63 0.82	0.63 0.82	0.33 0.43	0.34 0.44	0.33 0.43	0.37 0.48	0.38 0.50	0.37 0.48
Struck capacity	m <sup>3</sup> yd <sup>3</sup>	0.59 0.77	0.59 0.77	0.59 0.77	0.24 0.31	0.24 0.31	0.24 0.31	0.26 0.34	0.26 0.34	0.26 0.34
Width	mm in	2187 86.1	2198 86.5	2187 86.1	1730 68.1	1740 68.5	1730 68.1	1883 74.1	1893 74.5	1883 74.1
Dump clearance at maximum lift/dump	mm in	* *	* *	* *	2461 96.9	2446 96.3	2385 93.9	2461 96.9	2446 96.3	2385 93.9
Reach at maximum lift/dump	mm in	* *	* *	* *	790 31.1	804 31.7	865 34.1	790 31.1	804 31.7	865 34.1
Floor angle at maximum lift/dump	degrees	* *	* *	* *	40° 40°	40° 40°	40° 40°	40° 40°	40° 40°	40° 40°
Floor angle at maximum lift/rack back	degrees	* *	* *	* *	85° 85°	85° 85°	85° 85°	85° 85°	85° 85°	85° 85°
Clearance at maximum lift/level bucket	mm in	* *	* *	* *	3083 121.4	3066 120.7	3083 121.4	3083 121.4	3066 120.7	3083 121.4
Hinge pin height at maximum lift	mm in	* *	* *	* *	3279 129.1	3279 129.1	3279 129.1	3279 129.1	3279 129.1	3279 129.1
Maximum overall height	mm in	* *	* *	* *	4141 163.0	4166 164.0	4201 165.4	4141 163.0	4166 164.0	4201 165.4
Reach at level lift arm/bucket	mm in	* *	* *	* *	1330 52.4	1358 53.5	1330 52.4	1330 52.4	1358 53.5	1330 52.4
Maximum floor angle at minimum lift	degrees	26° 26°	26° 26°	26° 26°	26.1° 26.1°	26.1° 26.1°	26.1° 26.1°	26.1° 26.1°	26.1° 26.1°	26.1° 26.1°
Dig depth with level bucket	mm in	* *	* *	* *	18 0.7	34 1.3	18 0.7	18 0.7	34 1.3	18 0.7
Overall length with bucket on ground	mm in	* *	* *	* *	3886 153.0	3914 154.1	3994 157.2	3886 153.0	3914 154.1	3994 157.2
Front clearance circle radius (with bucket)	mm in	* *	* *	* *	2546 100.2	2567 101.1	2602 102.4	2579 101.5	2600 102.4	2635 103.7
Tipping load	kg lb	2721 5999	2650 5842	2697 5946	2683 5915	2620 5776	2665 2163	2664 5873	2598 5728	2644 5829
Breakout force — lift	kg lb	2183 4813	2121 4676	2165 4773	2179 4804	2126 4687	2163 4769	2163 4769	2107 4645	2148 4736
Breakout force — tilt	kg lb	2743 6047	2603 5739	2725 6008	3006 6627	2851 6285	2989 6590	2997 6607	2841 6263	2981 6572
Operating weight	kg lb	3828 8439	3870 8532	3846 8478	3912 8624	3945 8697	3929 8662	3932 8669	3968 8748	3949 8706

\*Information not available at time of printing.

Bucket Type		Multi-Purpose			Dirt					
Bucket Width Tire Size		1981 mm (78") 12 x 16.5			1680 mm (66") 12 x 16.5		1830 mm (72") 12 x 16.5		1981 mm (78") 12 x 16.5	
Ground Engaging Type		Holes Only	Bolt-on Edge	Bolt-on Teeth	Holes Only	Bolt-on Edge	Holes Only	Bolt-on Edge	Holes Only	Bolt-on Edge
Bucket Assembly No.		279-5403	279-5402	279-5401	279-5440	279-5441	285-6089	285-6090	268-4084	268-4083
Rated bucket capacity	m <sup>3</sup> yd <sup>3</sup>	0.40 0.52	0.42 0.55	0.40 0.52	0.37 0.48	0.38 0.50	0.40 0.52	0.42 0.55	0.44 0.58	0.45 0.59
Struck capacity	m <sup>3</sup> yd <sup>3</sup>	0.28 0.37	0.28 0.37	0.28 0.37	0.27 0.35	0.27 0.35	0.29 0.38	0.30 0.39	0.32 0.42	0.32 0.42
Width	mm in	2035 80.1	2045 80.5	2035 80.1	1676 66.0	1686 66.4	1829 72.0	1839 72.4	1981 78.0	1991 78.4
Dump clearance at maximum lift/dump	mm in	2461 96.9	2446 96.3	2385 93.9	2487 97.9	2473 97.4	2487 97.9	2473 97.4	2487 97.9	2473 97.4
Reach at maximum lift/dump	mm in	790 31.1	804 31.7	865 34.1	764 30.1	778 30.6	764 30.1	778 30.6	764 30.1	778 30.6
Floor angle at maximum lift/dump	degrees	40°	40°	40°	40°	40°	40°	40°	40°	40°
Floor angle at maximum lift/rack back	degrees	85°	85°	85°	85°	85°	85°	85°	85°	85°
Clearance at maximum lift/level bucket	mm in	3083 121.4	3066 120.7	3083 121.4	3089 121.6	3072 120.9	3089 121.6	3072 120.9	3089 121.6	3072 120.9
Hinge pin height at maximum lift	mm in	3279 129.1	3279 129.1	3279 129.1	3279 129.1	3279 129.1	3279 129.1	3279 129.1	3279 129.1	3279 129.1
Maximum overall height	mm in	4141 163.0	4166 164.0	4201 165.4	4115 162.0	4140 163.0	4115 162.0	4140 163.0	4115 162.0	4140 163.0
Reach at level lift arm/bucket	mm in	1330 52.4	1358 53.5	1330 52.4	1251 49.3	1298 51.1	1251 49.3	1298 51.1	1251 49.3	1298 51.1
Maximum floor angle at minimum lift	degrees	26.1°	26.1°	26.1°	26.4°	26.4°	26.4°	26.4°	26.4°	26.4°
Dig depth with level bucket	mm in	18 0.7	34 1.3	18 0.7	10 0.4	26 1.0	10 0.4	26 1.0	10 0.4	26 1.0
Overall length with bucket on ground	mm in	3886 153.0	3914 154.1	3994 157.2	3833 150.9	3861 152.0	3833 150.9	3861 152.0	3833 150.9	3861 152.0
Front clearance circle radius (with bucket)	mm in	2603 102.5	2636 103.8	2671 105.2	2520 99.2	2541 100.0	2553 100.5	2574 101.3	2577 101.5	2610 102.8
Tipping load	kg lb	2660 5864	2590 5710	2636 5811	2951 6506	2875 6338	2939 6479	2859 6303	2928 6455	2844 6270
Breakout force — lift	kg lb	2148 4736	2090 4608	2130 4696	2352 5185	2295 5060	2340 5159	2281 5029	2330 5137	2268 5000
Breakout force — tilt	kg lb	2988 6587	2830 6239	2969 6545	3034 6689	2917 6431	3024 6667	2905 6404	3017 6651	2895 6382
Operating weight	kg lb	3951 8710	3988 8792	3969 8750	3756 8281	3789 8353	3769 8309	3805 8389	3783 8340	3823 8428

Work Tool	Pallet Fork		
	910 mm (36")	1070 mm (42")	1220 mm (48")
<b>Tine Length</b>	<b>910 mm (36")</b>	<b>1070 mm (42")</b>	<b>1220 mm (48")</b>
<b>Tire Size</b>	<b>12 x 16.5</b>	<b>12 x 16.5</b>	<b>12 x 16.5</b>
<b>Carriage Assembly No.</b>	<b>293-9427</b>	<b>293-9428</b>	<b>293-9429</b>
Carriage overall width without step	mm in	1159 45.6	1159 45.6
Carriage step additional width	mm in	106 4.2	106 4.2
Carriage height above blade top	mm in	930 36.6	930 36.6
Blade surface height at maximum height	mm in	3130 123.2	3130 123.2
Shank front face reach at maximum height	mm in	697 27.4	697 27.4
Blade surface height at level lift arms	mm in	1608 63.3	1608 63.3
Shank front face reach at level lift arms	mm in	738 29.1	738 29.1
Blade surface height at minimum lift	mm in	90 3.5	90 3.5
Shank front face reach at minimum lift	mm in	410 16.1	410 16.1
Overall length at minimum lift, level tine	mm in	4186 164.8	4186 164.8
Tipping load	kg lb	2240 4938	2127 4689
Operating weight	kg lb	3745 8256	3755 8278
			3764 8298

- 216B2/226B2/232B2

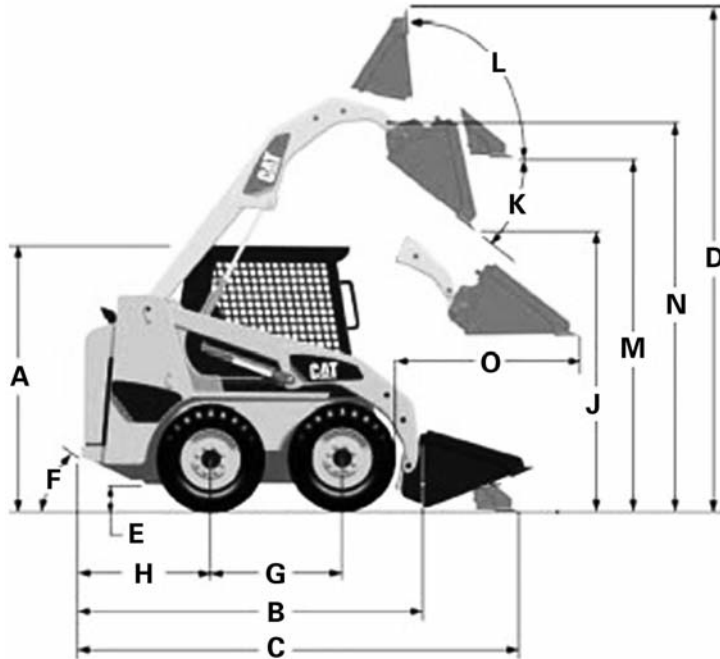

MODEL	216B2		226B2		232B2	
Rated operating capacity*	635 kg	<b>1400 lb</b>	680 kg	<b>1500 lb</b>	862 kg	<b>1900 lb</b>
A Height to top of ROPS	1950 mm	<b>6'5"</b>	1950 mm	<b>6'5"</b>	1953 mm	<b>6'5"</b>
B Length to coupler	2519 mm	<b>8'3"</b>	2519 mm	<b>8'3"</b>	2760 mm	<b>9'1"</b>
C Length with bucket on ground	3233 mm	<b>10'7"</b>	3233 mm	<b>10'7"</b>	3437 mm	<b>11'3"</b>
D Maximum overall height	3709 mm	<b>12'2"</b>	3709 mm	<b>12'2"</b>	3894 mm	<b>12'9"</b>
E Ground clearance	195 mm	<b>8"</b>	195 mm	<b>8"</b>	145 mm	<b>5.7"</b>
F Departure angle		<b>26°</b>		<b>26°</b>		<b>28°</b>
G Wheelbase	986 mm	<b>3'3"</b>	986 mm	<b>3'3"</b>	1094 mm	<b>3'7"</b>
H Bumper overhang from axle	967 mm	<b>3'2"</b>	967 mm	<b>3'2"</b>	989 mm	<b>3'3"</b>
Bucket overall width	1524 mm	<b>5'2"</b>	1524 mm	<b>5'2"</b>	1524 mm	<b>5'2"</b>
J Clearance at maximum lift/dump	2169 mm	<b>7'1"</b>	2169 mm	<b>7'1"</b>	2243 mm	<b>7'3"</b>
K Floor angle at maximum lift/dump		<b>40°</b>		<b>40°</b>		<b>49.5°</b>
L Floor angle at maximum lift/rack		<b>96.7°</b>		<b>96.7°</b>		<b>86.9°</b>
M Clearance at maximum lift/level	2661 mm	<b>8'9"</b>	2661 mm	<b>8'9"</b>	2851 mm	<b>9'4"</b>
N Hinge pin height at maximum lift	2854 mm	<b>9'4"</b>	2854 mm	<b>9'4"</b>	3013 mm	<b>9'11"</b>
O Reach at level lift arm/bucket	1280 mm	<b>4'2"</b>	1280 mm	<b>4'2"</b>	1231 mm	<b>4'1"</b>
Hinge pin height at carry position	239 mm	<b>9.3"</b>	239 mm	<b>9.3"</b>	247 mm	<b>9.7"</b>
Maximum floor angle at carry position		<b>27.7°</b>		<b>27.7°</b>		<b>28.1°</b>

\*SAE J818 MAY87, ISO 5998:1986.

**NOTE:** 216B2/226B2 machine dimensions shown with standard machine equipped with optional 10 x 16.5 10 PR tires and 1520 mm (60") dirt bucket.  
232B2 machine dimensions shown with standard machine equipped with optional 10 x 16.5 x 8 PR tires and 1730 mm (66") dirt bucket.

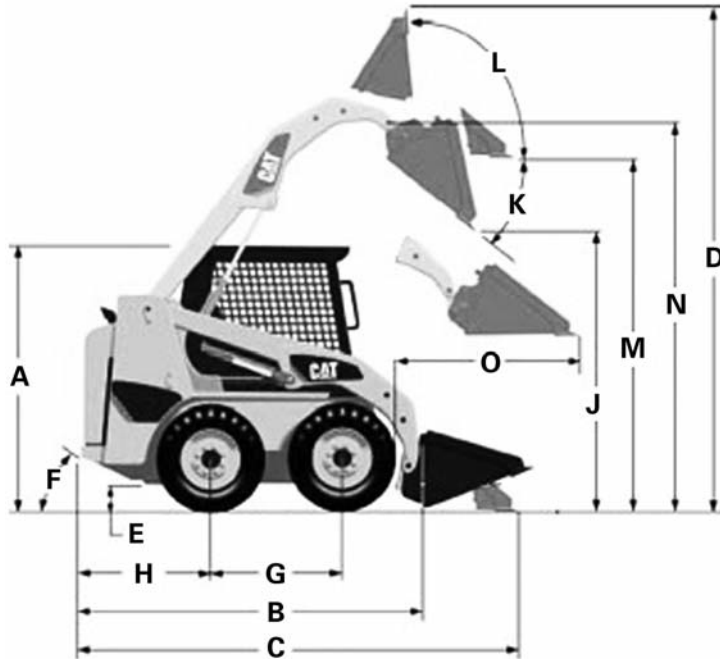

MODEL	236B2		242B2		252B2	
Rated operating capacity*	884 kg	<b>1950 lb</b>	952 kg	<b>2100 lb</b>	1134 kg	<b>2500 lb</b>
A Height to top of ROPS	2092 mm	<b>6'10"</b>	1986 mm	<b>6'6"</b>	2063 mm	<b>6'8"</b>
B Length to coupler	2800 mm	<b>9'2"</b>	2760 mm	<b>9'1"</b>	2901 mm	<b>9'5"</b>
C Length with bucket on ground	3515 mm	<b>11'6"</b>	3437 mm	<b>11'3"</b>	3616 mm	<b>11'9"</b>
D Maximum overall height	3965 mm	<b>13'0"</b>	3926 mm	<b>12'11"</b>	4062 mm	<b>13'4"</b>
E Ground clearance	235 mm	<b>9"</b>	178 mm	<b>7"</b>	196 mm	<b>8"</b>
F Departure angle		<b>28°</b>		<b>28°</b>		<b>27°</b>
G Wheelbase	1134 mm	<b>3'9"</b>	1094 mm	<b>3'7"</b>	1228 mm	<b>4'0"</b>
H Bumper overhang from axle	1038 mm	<b>3'5"</b>	989 mm	<b>3'3"</b>	1043 mm	<b>3'4"</b>
Bucket overall width	1730 mm	<b>5'8"</b>	1524 mm	<b>5'2"</b>	1730 mm	<b>5'8"</b>
J Clearance at maximum lift/dump	2398 mm	<b>7'10"</b>	2270 mm	<b>7'4"</b>	2421 mm	<b>8'0"</b>
K Floor angle at maximum lift/dump		<b>40°</b>		<b>49.5°</b>		<b>51°</b>
L Floor angle at maximum lift/rack		<b>97.4°</b>		<b>86.9°</b>		<b>87°</b>
M Clearance at maximum lift/level	2908 mm	<b>9'6"</b>	2851 mm	<b>9'4"</b>	3039 mm	<b>10'0"</b>
N Hinge pin height at maximum lift	3099 mm	<b>10'2"</b>	3046 mm	<b>10'0"</b>	3210 mm	<b>10'6"</b>
O Reach at level lift arm/bucket	1357 mm	<b>4'5"</b>	1231 mm	<b>4'1"</b>	1331 mm	<b>4'4"</b>
Hinge pin height at carry position	257 mm	<b>10"</b>	299 mm	<b>11.8"</b>	213 mm	<b>8.4"</b>
Maximum floor angle at carry position		<b>29.4°</b>		<b>28.1°</b>		<b>27°</b>

\*SAE J818 MAY87, ISO 5998:1986.

**NOTE:** 236B2/242B2/252B2 machine dimensions shown with standard machine equipped with optional 12 x 16.5 10 PR tires and 1730 mm (66") dirt bucket.

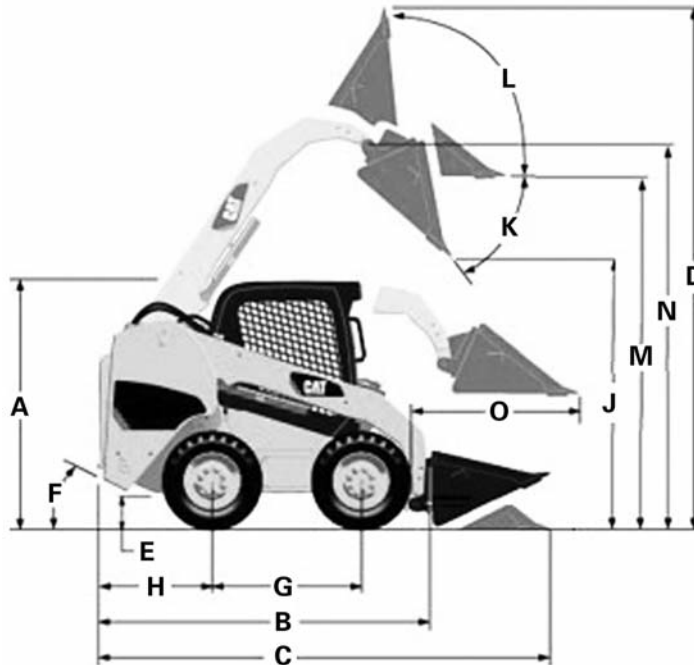

MODEL	246C		256C		262C		272C	
Rated operating capacity*	975 kg	<b>2150 lb</b>	1066 kg	<b>2352 lb</b>	1225 kg	<b>2700 lb</b>	1474 kg	<b>3250 lb</b>
A Height to top of ROPS	2104 mm	<b>6'11"</b>	2104 mm	<b>6'11"</b>	2104 mm	<b>6'11"</b>	2104 mm	<b>6'11"</b>
B Length to coupler	2979 mm	<b>9'9"</b>	2979 mm	<b>9'9"</b>	2979 mm	<b>9'9"</b>	3120 mm	<b>10'2"</b>
C Length with bucket on ground	3692 mm	<b>12'1"</b>	3692 mm	<b>12'1"</b>	3692 mm	<b>12'1"</b>	3833 mm	<b>12'7"</b>
D Maximum overall height	3998 mm	<b>13'1"</b>	3998 mm	<b>13'1"</b>	4075 mm	<b>13'4"</b>	4115 mm	<b>13'6"</b>
E Ground clearance	225 mm	<b>8.9"</b>	225 mm	<b>8.9"</b>	225 mm	<b>8.9"</b>	225 mm	<b>8.9"</b>
F Departure angle		<b>26°</b>		<b>26°</b>		<b>26°</b>		<b>26°</b>
G Wheelbase	1240 mm	<b>4'1"</b>	1240 mm	<b>4'1"</b>	1240 mm	<b>4'1"</b>	1381 mm	<b>4'6"</b>
H Bumper overhang from axle	1089 mm	<b>3'7"</b>	1089 mm	<b>3'7"</b>	1089 mm	<b>3'7"</b>	1089 mm	<b>3'7"</b>
Bucket overall width	1677 mm	<b>5'6"</b>	1677 mm	<b>5'6"</b>	1829 mm	<b>6'0"</b>	1829 mm	<b>6'0"</b>
J Clearance at maximum lift/dump	2425 mm	<b>7'11"</b>	2425 mm	<b>7'11"</b>	2450 mm	<b>8'0"</b>	2487 mm	<b>8'2"</b>
K Floor angle at maximum lift/dump		<b>40°</b>		<b>40°</b>		<b>50°</b>		<b>51°</b>
L Floor angle at maximum lift/rack		<b>85°</b>		<b>85°</b>		<b>85°</b>		<b>83°</b>
M Clearance at maximum lift/level	2930 mm	<b>9'7"</b>	2930 mm	<b>9'7"</b>	3043 mm	<b>10'0"</b>	3088 mm	<b>10'2"</b>
N Hinge pin height at maximum lift	3122 mm	<b>10'3"</b>	3122 mm	<b>10'3"</b>	3233 mm	<b>10'7"</b>	3279 mm	<b>10'9"</b>
O Reach at level lift arm/bucket	1388 mm	<b>4'7"</b>	1388 mm	<b>4'7"</b>	1283 mm	<b>4'3"</b>	1270 mm	<b>4'2"</b>
Hinge pin height at carry position	200 mm	<b>7.8"</b>	200 mm	<b>7.8"</b>	200 mm	<b>7.8"</b>	200 mm	<b>7.8"</b>
Maximum floor angle at carry position		<b>26°</b>		<b>26°</b>		<b>26°</b>		<b>26°</b>

\*SAE J818 MAY87, ISO 5998:1986.

NOTE: 246C/256C machine dimensions shown with standard machine equipped with optional 12 x 16.5 10 PR tires and 1730 mm (66") dirt bucket.  
262C/272C machine dimensions shown with standard machine equipped with optional 12 x 16.5 10 PR tires and 1829 mm (72") dirt bucket.

**CAT WORK TOOL COMPATIBILITY**

	216B2	226B2	232B2	236B2	242B2	252B2	246C	256C	262C	272C
<b>General Purpose Buckets</b>										
1524 mm (60")	O	O	A	A	A	NR	A	A	NR	NR
1676 mm (66")	A	A	O	O	O	O	O	O	A	A
1829 mm (72")	NR	NR	A	O	A	O	O	O	O	O
1981 mm (78")	NR	NR	NR	A	A	O	A	A	O	O
<b>High Capacity Bucket (GP)</b>										
2134 mm (84")	NR	NR	NR	A	A	O	A	A	O	O
<b>Dirt Buckets</b>										
1524 mm (60")	O	O	A	A	A	NR	A	A	NR	NR
1676 mm (66")	A	A	O	O	O	O	O	O	A	A
1829 mm (72")	NR	NR	A	O	A	O	O	O	O	O
1981 mm (78")	NR	NR	NR	A	A	O	A	A	O	O
<b>Utility Buckets</b>										
1524 mm (60")	O	O	A	A	A	NR	A	A	NR	NR
1676 mm (66")	A	A	O	O	O	O	O	O	A	A
1829 mm (72")	NR	NR	A	O	A	O	O	O	O	O
<b>Light Material Buckets</b>										
1829 mm (72")	O	O	O	O	O	O	O	O	O	O
1981 mm (78")	NR	NR	A	A	A	O	A	A	O	O
2134 mm (84")	NR	NR	NR	A	A	O	A	A	O	O
2438 mm (96")	NR	NR	NR	NR	NR	A	A	A	O	O
<b>Multi-Purpose Buckets</b>										
1524 mm (60")	O	O	A	A	A	NR	A	A	NR	NR
1676 mm (66")	A	A	O	O	O	O	O	O	A	A
1829 mm (72")	NR	NR	A	O	A	O	O	O	O	O
1981 mm (78")	NR	NR	NR	A	NR	A	A	A	O	O
2134 mm (84")	NR	NR	NR	A	NR	O	A	A	O	O
<b>Industrial Grapple Buckets</b>										
1524 mm (60")	O	O	A	A	A	NR	A	A	NR	NR
1676 mm (66")	A	A	O	O	O	O	O	O	A	A
1829 mm (72")	NR	NR	A	O	A	O	O	O	O	O
1981 mm (78")	NR	NR	NR	A	NR	A	A	A	O	O
<b>Industrial Grapple Forks</b>										
1676 mm (66")	O	O	O	O	O	O	O	O	O	O
1829 mm (72")	NR	NR	A	O	A	O	O	O	O	O
<b>Industrial Grapple Rakes</b>										
1829 mm (72")	O	O	O	O	O	O	O	O	O	O
2134 mm (84")	NR	NR	NR	A	NR	O	O	O	O	O
<b>Utility Grapple Buckets</b>										
1524 mm (60")	O	O	A	A	A	NR	A	A	NR	NR
1676 mm (66")	O	O	O	O	O	O	O	O	A	A
1829 mm (72")	NR	NR	A	O	A	O	O	O	O	O

O – Provides Optimum Performance.  
 A – Provides Acceptable Performance.  
 NR – Not Recommended.



**CAT WORK TOOL COMPATIBILITY**

	216B2	226B2	232B2	236B2	242B2	252B2	246C	256C	262C	272C
<b>Carriage</b>	O	O	O	O	O	O	O	O	O	O
<b>Pallet Forks</b>										
910 mm (36") Tines	O	O	O	O	O	O	O	O	O	O
1070 mm (42") Tines	O	O	O	O	O	O	O	O	O	O
1220 mm (48") Tines	O	O	O	O	O	O	O	O	O	O
<b>Utility Grapple Forks</b>										
1676 mm (66")	O	O	O	O	O	O	O	O	O	O
1829 mm (72")	NR	NR	A	O	A	O	O	O	O	O
<b>Utility Forks</b>										
1676 mm (66")	O	O	O	O	O	O	O	O	O	O
1829 mm (72")	NR	NR	A	O	A	O	O	O	O	O
<b>Angle Blades</b>										
1829 mm (72")	O	O	O	A	O	A	A	A	A	A
2134 mm (84")	A	A	A	O	A	O	O	O	O	O
<b>6 Way Blades</b>										
2000 mm (79")	O	O	O	A	O	A	A	A	A	A
2337 mm (92")	A	A	A	O	O	O	O	O	O	O
<b>A14B Auger</b>	O	O	O	O	O	O	O	O	O	O
<b>A19B Auger</b>	A	A	A	O	A	O	O	O	O	O
<b>A26B Auger</b>	X	A#	X	X	A#	X	A#	O#	O#	O#
<b>Backhoe</b>										
BH150	O	O	O	O	O	O	X	X	X	X
BH160	X	X	X	X	X	X	O	O	O	O
BH27	O	O	O	O	O	O	X	X	X	X
BH30	O	O	O	O	O	O	X	X	X	X
BH30W	X	X	X	X	X	X	O	O	O	O
<b>BR160 Brushcutter</b>	O	O	O	O	O	O	O	O	O	O
<b>BR166 Brushcutter</b>	O	O	O	O	O	O	O	O	O	O
<b>BR172 Brushcutter</b>	O	O	O	O	O	O	O	O	O	O
<b>BR272 Brushcutter</b>	X	O#	X	X	O#	X	X	X	X	X
<b>BR378 Brushcutter</b>	X	X	X	X	X	X	A#	O#	O#	O#
<b>BP15B Pickup Broom</b>	O!	O	O	O	O	A	O	O	A	A
<b>BP18B Pickup Broom</b>	X	X	O	O	O	O	O	O	O	O
<b>BA18 Angle Broom</b>	O	O	O	O	O	O	O	O	O	O
<b>BU115 Utility Broom</b>	O!	O	O	O	O	A	O	O	A	A
<b>BU118 Utility Broom</b>	X	X	O	O	O	O	O	O	O	O

O – Provides Optimum Performance.

O# – The machine performance is optimum with the available HF/XPS option.

A – Provides Acceptable Performance.

A# – The machine performance is acceptable with the available HF/XPS option.

NR – Not Recommended.

X – Not Approved. Do Not Use.

! – Lift Restriction.

**CAT WORK TOOL COMPATIBILITY**

	216B2	226B2	232B2	236B2	242B2	252B2	246C	256C	262C	272C
PC203 Cold Planer	O	O	O	O	O	O	O	O	O	O
PC204 Cold Planer	X	A	X	O	A	O	O	O	O	O
PC205 Cold Planer	X	A#	X	X	A#	X	A#	O#	O#	O#
PC206 Cold Planer	X	A#	X	X	A#	X	A#	O#	O#	O#
PC210 Cold Planer	X	X	X	X	X	X	A#	O#	O#	O#
H55D S Hammer	O	O	O	O	O	O	O	O	O	O
H65D S Hammer	O	O	O	O	O	O	O	O	O	O
LR15B Landscape Rake	O!	O!	O!	O!	O!	O!	O	O	O	O
LR18B Landscape Rake	X	X	X	O!	X	O!	O	O	O	O
LT13B Landscape Tiller	O	O	O	O	O	O	O	O	O	O
LT18B Landscape Tiller	X	X	X	O	X	O	O	O	O	O
Material Handling Arm	O	O	O	O	O	O	O	O	O	O
HM312 Mulcher	X	X	X	X	X	X	A#	O#	O#	O#
HM315 Mulcher	X	X	X	X	X	X	A#	O#	O#	O#
PR172 Power Box Rake	O	O	O	A	A	A	A	A	A	A
PR184 Power Box Rake	A	O	A	O	O	O	O	O	O	O
PR190 Power Box Rake	A	A	A	O	A	O	O	O	O	O
SR117 Snowblower	O	O	O	NR	O	NR	A	A	NR	NR
SR118 Snowblower	NR	NR	NR	O	NR	O	O	O	O	O
SR121 Snowblower	NR	NR	NR	A	NR	A	A	A	A	A
SR318 Snowblower	NR	A#	NR	NR	A#	NR	A#	O#	O#	O#
SR321 Snowblower	NR	A#	NR	NR	A#	NR	A#	O#	O#	O#
SG16B Stump Grinder	O	O	O	O	O	O	O	O	O	O
SG18B Stump Grinder	X	A#	X	X	A#	X	A#	O#	O#	O#
T6B Trencher	O	O	O	O	O	O	O	O	O	O
T9B Trencher	O	O	O	O	O	O	O	O	O	O
T15 Trencher	X	A#	X	X	A#	X	X	O#	O#	O#
CV16B Vibratory Compactor	O!	O!	O!	O!	O!	O	O	O	O	O
CV18B Vibratory Compactor	X	X	X	X	X	O	O	O	O	O
SW45 Wheel Saw	X	X	X	X	X	X	O#,C	O#,C	O#,C	O#
SW60 Wheel Saw	X	X	X	X	X	X	O#,C	O#,C	O#,C	O#

O – Provides Optimum Performance.  
 O# – The machine performance is optimum with the available HF/XPS option.  
 A – Provides Acceptable Performance.  
 A# – The machine performance is acceptable with the available HF/XPS option.  
 NR – Not Recommended.  
 X – Not Approved. Do Not Use.  
 ! – Lift Restriction.  
 C – Maximum Counterweights are Required.



MODEL	247B2		257B2	
Flywheel Power: Net	42 kW	56 hp	42 kW	56 hp
Gross	46 kW	62 hp	46 kW	62 hp
Engine Model	<b>C2.2T</b>		<b>C2.2T</b>	
Rated Engine RPM	<b>3000</b>		<b>3000</b>	
Bore	84 mm	3.3"	84 mm	3.3"
Stroke	100 mm	3.9"	100 mm	3.9"
Displacement	2.2 L	134 in <sup>3</sup>	2.2 L	134 in <sup>3</sup>
No. Cylinders	4		4	
One Speed Forward	0-11.3 km/h	<b>0-7.0 mph</b>	0-11.3 km/h	<b>0-7.0 mph</b>
One Speed Reverse	0-12.2 km/h	<b>0-7.6 mph</b>	0-11.4 km/h	<b>0-7.1 mph</b>
Hydraulic Cycle Time, Empty Bucket:	<b>Seconds</b>		<b>Seconds</b>	
Raise	2.7		3.0	
Dump	2.2		2.2	
Lower (Empty, Float Down)	2.8		3.0	
Total	7.7		8.2	
Tread Width (per side)	381 mm	15"	381 mm	15"
Width Over Tracks	1676 mm	5'6"	1676 mm	5'6"
Ground Clearance	267 mm	10"	257 mm	10"
Fuel Tank Capacity	62 L	<b>16.2 U.S. gal</b>	84 L	<b>22.2 U.S. gal</b>
Hydraulic Tank Capacity	35 L	<b>9.2 U.S. gal</b>	35 L	<b>9.2 U.S. gal</b>
Hydraulic System Capacity (includes tank)	55 L	<b>14.5 U.S. gal</b>	55 L	<b>14.5 U.S. gal</b>
Hydraulic Pump Capacity	60 L/min	<b>15.6 gpm</b>	60 L/min	<b>15.6 gpm</b>

Specifications  
 • 277C/287C/297C

Multi Terrain Loaders



MODEL	277C		287C		297C	
Flywheel Power: Net	61 kW	<b>82 hp</b>	61 kW	<b>82 hp</b>	67 kW	<b>90 hp</b>
Gross	63 kW	<b>84 hp</b>	63 kW	<b>84 hp</b>	70 kW	<b>94 hp</b>
Engine Model	<b>C3.4 DIT</b>		<b>C3.4 DIT</b>		<b>C3.4 DIT</b>	
Rated Engine RPM	<b>2500</b>		<b>2500</b>		<b>2500</b>	
Bore	94 mm	<b>3.7"</b>	94 mm	<b>3.7"</b>	94 mm	<b>3.7"</b>
Stroke	120 mm	<b>4.7"</b>	120 mm	<b>4.7"</b>	120 mm	<b>4.7"</b>
Displacement	3.3 L	<b>201 in<sup>3</sup></b>	3.3 L	<b>201 in<sup>3</sup></b>	3.3 L	<b>201 in<sup>3</sup></b>
No. Cylinders	<b>4</b>		<b>4</b>		<b>4</b>	
One Speed Forward	0-9 km/h	<b>0-5.6 mph</b>	0-9 km/h	<b>0-5.6 mph</b>	0-9 km/h	<b>0-5.6 mph</b>
Two Speed Forward	0-14.9 km/h	<b>0-9.2 mph</b>	0-14.9 km/h	<b>0-9.2 mph</b>	0-14.9 km/h	<b>0-9.2 mph</b>
One Speed Reverse	0-9 km/h	<b>0-5.6 mph</b>	0-9 km/h	<b>0-5.6 mph</b>	0-9 km/h	<b>0-5.6 mph</b>
Two Speed Reverse	0-14.9 km/h	<b>0-9.2 mph</b>	0-14.9 km/h	<b>0-9.2 mph</b>	0-14.9 km/h	<b>0-9.2 mph</b>
Hydraulic Cycle Time, Empty Bucket:	<b>Seconds</b>		<b>Seconds</b>		<b>Seconds</b>	
Raise	<b>3.1</b>		<b>4.7</b>		<b>4.7</b>	
Dump	<b>2.5</b>		<b>2.5</b>		<b>2.5</b>	
Lower (Empty, Float Down)	<b>4.0</b>		<b>4.6</b>		<b>4.6</b>	
Total	<b>9.6</b>		<b>11.8</b>		<b>11.8</b>	
Tread Width (per side)	457 mm	<b>18"</b>	457 mm	<b>18"</b>	457 mm	<b>18"</b>
Width Over Tracks	1981 mm	<b>78"</b>	1981 mm	<b>78"</b>	1981 mm	<b>78"</b>
Ground Clearance	225 mm	<b>8.9"</b>	225 mm	<b>8.9"</b>	225 mm	<b>8.9"</b>
Fuel Tank Capacity	98 L	<b>26 U.S. gal</b>	98 L	<b>26 U.S. gal</b>	98 L	<b>26 U.S. gal</b>
Hydraulic Tank Capacity	42 L	<b>11 U.S. gal</b>	42 L	<b>11 U.S. gal</b>	42 L	<b>11 U.S. gal</b>
Hydraulic System Capacity (includes tank)	57 L	<b>15 U.S. gal</b>	57 L	<b>15 U.S. gal</b>	57 L	<b>15 U.S. gal</b>
Hydraulic Pump Capacity	84 L/min	<b>22 gpm</b>	84 L/min	<b>22 gpm</b>	84 L/min	<b>22 gpm</b>

Bucket Type		General Purpose						Multi-Purpose	
		1680 mm (66")			1829 mm (72")			1680 mm (66")	
Bucket Width		Holes Only	Bolt-on Edge	Bolt-on Teeth	Holes Only	Bolt-on Edge	Bolt-on Teeth	Holes Only	Bolt-on Edge
Ground Engaging Type									
Bucket Assembly No.		165-6153	152-0226	152-0225	165-6154	152-0229	152-0228	154-5008	154-5047
Rated bucket capacity	m <sup>3</sup>	0.40	0.40	0.41	0.44	0.44	0.45	0.33	0.33
	yd <sup>3</sup>	<b>0.52</b>	<b>0.52</b>	<b>0.53</b>	<b>0.57</b>	<b>0.57</b>	<b>0.59</b>	<b>0.43</b>	<b>0.43</b>
Struck capacity	m <sup>3</sup>	0.29	0.29	0.29	0.32	0.32	0.32	0.24	0.25
	yd <sup>3</sup>	<b>0.38</b>	<b>0.38</b>	<b>0.38</b>	<b>0.42</b>	<b>0.42</b>	<b>0.42</b>	<b>0.31</b>	<b>0.33</b>
Width	mm	1730	1740	1730	1883	1893	1883	1749	1749
	in	<b>68.0</b>	<b>68.0</b>	<b>68.0</b>	<b>74.0</b>	<b>75.0</b>	<b>74.0</b>	<b>69.0</b>	<b>69.0</b>
Dump clearance at maximum lift/dump	mm	2134	2101	2067	2134	2101	2067	2133	2103
	in	<b>84.0</b>	<b>82.7</b>	<b>81.4</b>	<b>84.0</b>	<b>82.7</b>	<b>81.4</b>	<b>84.0</b>	<b>82.8</b>
Reach at maximum lift/dump	mm	625	637	696	625	637	696	628	640
	in	<b>24.6</b>	<b>25.1</b>	<b>27.4</b>	<b>24.6</b>	<b>25.1</b>	<b>27.4</b>	<b>24.7</b>	<b>25.2</b>
Floor angle at maximum lift/dump	degrees	<b>40.8°</b>	<b>40.8°</b>	<b>40.8°</b>	<b>40.8°</b>	<b>40.8°</b>	<b>40.8°</b>	<b>40.8°</b>	<b>40.8°</b>
Floor angle at maximum lift/rack back	degrees	<b>95.7°</b>	<b>95.7°</b>	<b>95.7°</b>	<b>95.7°</b>	<b>95.7°</b>	<b>95.7°</b>	<b>95.6°</b>	<b>95.6°</b>
Clearance at maximum lift/level bucket	mm	2667	2651	2666	2667	2651	2666	2673	2653
	in	<b>105.0</b>	<b>104.4</b>	<b>105.0</b>	<b>105.0</b>	<b>104.4</b>	<b>105.0</b>	<b>105.2</b>	<b>104.4</b>
Hinge pin height at maximum lift	mm	2862	2862	2862	2862	2862	2862	2862	2862
	in	<b>112.7</b>	<b>112.7</b>	<b>112.7</b>	<b>112.7</b>	<b>112.7</b>	<b>112.7</b>	<b>112.7</b>	<b>112.7</b>
Maximum overall height	mm	3770	3799	3867	3770	3799	3867	3774	3804
	in	<b>148.4</b>	<b>149.6</b>	<b>152.2</b>	<b>148.4</b>	<b>149.6</b>	<b>152.2</b>	<b>148.6</b>	<b>149.8</b>
Reach at level lift arm/bucket	mm	1395	1423	1493	1395	1423	1493	1399	1427
	in	<b>54.9</b>	<b>56.0</b>	<b>58.8</b>	<b>54.9</b>	<b>56.0</b>	<b>58.8</b>	<b>55.1</b>	<b>56.2</b>
Maximum floor angle at minimum lift	degrees	<b>25.4°</b>	<b>25.4°</b>	<b>25.4°</b>	<b>25.4°</b>	<b>25.4°</b>	<b>25.4°</b>	<b>25.3°</b>	<b>25.3°</b>
Dig depth with level bucket	mm	0	16	1	0	16	1	0	16
	in	<b>0.0</b>	<b>0.6</b>	<b>0.0</b>	<b>0.0</b>	<b>0.6</b>	<b>0.0</b>	<b>0.0</b>	<b>0.6</b>
Overall length with bucket on ground	mm	3285	3313	3382	3285	3313	3382	3289	3317
	in	<b>129.3</b>	<b>130.4</b>	<b>133.1</b>	<b>129.3</b>	<b>130.4</b>	<b>133.1</b>	<b>129.5</b>	<b>130.6</b>
Front clearance circle radius (with bucket)	mm	2157	2189	2223	2189	2221	2251	2142	2174
	in	<b>84.9</b>	<b>86.2</b>	<b>87.5</b>	<b>86.2</b>	<b>87.4</b>	<b>88.6</b>	<b>84.3</b>	<b>85.6</b>
Tipping load	kg	1811	1752	1715	1803	1740	1780	1663	1607
	lb	<b>3992</b>	<b>3863</b>	<b>3788</b>	<b>3975</b>	<b>3837</b>	<b>3925</b>	<b>3666</b>	<b>3542</b>
Breakout force — lift	kg	1408	1359	1392	1402	1350	1386	1298	1250
	lb	<b>3105</b>	<b>2996</b>	<b>3070</b>	<b>3091</b>	<b>2977</b>	<b>3056</b>	<b>2862</b>	<b>2755</b>
Breakout force — tilt	kg	1694	1590	1676	1689	1583	1673	1618	1517
	lb	<b>3734</b>	<b>3505</b>	<b>3696</b>	<b>3724</b>	<b>3491</b>	<b>3688</b>	<b>3567</b>	<b>3345</b>
Operating weight	kg	3169	3202	3185	3177	3212	3193	3302	3334
	lb	<b>6987</b>	<b>7060</b>	<b>7023</b>	<b>7004</b>	<b>7082</b>	<b>7040</b>	<b>7280</b>	<b>7352</b>

Bucket Type	Multi-Purpose				Dirt			
Bucket Width	1680 mm (66")	1829 mm (72")			1680 mm (66")		1829 mm (72")	
Ground Engaging Type	Bolt-on Teeth	Holes Only	Bolt-on Edge	Bolt-on Teeth	Holes Only	Bolt-on Edge	Holes Only	Bolt-on Edge
Bucket Assembly No.	154-5048	154-5010	154-5049	154-5050	165-6157	152-0232	188-3526	188-2719
Rated bucket capacity	m <sup>3</sup> yd <sup>3</sup> 0.34 0.44	0.37 0.48	0.37 0.48	0.37 0.48	0.37 0.48	0.38 0.49	0.41 0.54	0.42 0.55
Struck capacity	m <sup>3</sup> yd <sup>3</sup> 0.24 0.31	0.27 0.35	0.28 0.36	0.27 0.35	0.27 0.35	0.27 0.35	0.29 0.38	0.31 0.41
Width	mm in 1749 69.0	1902 75.0	1902 75.0	1902 75.0	1730 68.0	1740 69.0	1883 74.0	1893 75.0
Dump clearance at maximum lift/dump	mm in 2066 81.3	2133 84.0	2103 82.8	2066 81.3	2167 85.3	2138 84.2	2167 85.3	2138 84.2
Reach at maximum lift/dump	mm in 702 27.6	628 24.7	640 25.2	702 27.6	584 23.0	596 23.5	584 23.0	596 23.5
Floor angle at maximum lift/dump	degrees 40.8°	40.8°	40.8°	40.8°	40.8°	40.8°	40.8°	40.8°
Floor angle at maximum lift/rack back	degrees 95.6°	95.6°	95.6°	95.6°	95.7°	95.7°	95.7°	95.7°
Clearance at maximum lift/level bucket	mm in 2668 105.0	2673 105.2	2653 104.4	2668 105.0	2667 105.0	2651 104.4	2667 105.0	2651 104.4
Hinge pin height at maximum lift	mm in 2862 112.7	2862 112.7	2862 112.7	2862 112.7	2862 112.7	2862 112.7	2862 112.7	2862 112.7
Maximum overall height	mm in 3872 152.4	3774 148.6	3804 149.8	3872 152.4	3717 146.3	3746 147.5	3717 146.3	3746 147.5
Reach at level lift arm/bucket	mm in 1497 58.9	1399 55.1	1427 56.2	1497 58.9	1342 52.8	1370 53.9	1342 52.8	1370 53.9
Maximum floor angle at minimum lift	degrees 25.3°	25.3°	25.3°	25.3°	25.4°	25.4°	25.4°	25.4°
Dig depth with level bucket	mm in 1 0.0	0 0.0	16 0.6	1 0.0	0 0.0	13 0.5	0 0.0	13 0.5
Overall length with bucket on ground	mm in 3386 133.3	3289 129.5	3317 130.6	3386 133.3	3232 127.2	3260 128.3	3233 127.3	3261 128.4
Front clearance circle radius (with bucket)	mm in 2208 86.9	2152 84.7	2183 85.9	2213 87.1	2097 82.6	2128 83.8	2110 83.1	2141 84.3
Tipping load	kg lb 1643 3623	1645 3628	1586 3497	1625 3584	1913 4219	1849 4077	1906 4203	1838 4052
Breakout force — lift	kg lb 1282 2826	1283 2829	1233 2718	1267 2794	1478 3260	1428 3148	1472 3246	1419 3128
Breakout force — tilt	kg lb 1600 3528	1609 3548	1508 3326	1594 3514	1842 4061	1726 3806	1838 4052	1720 3792
Operating weight	kg lb 3318 7316	3320 7321	3356 7400	3337 7357	3119 6876	3151 6949	3126 6893	3162 6972

Work Tool		Pallet Fork		
		910 mm (36")	1070 mm (42")	1220 mm (48")
<b>Tine Length</b>				
<b>Carriage Assembly No.</b>		<b>242-9998</b>	<b>242-9999</b>	<b>243-0000</b>
Carriage overall width without step	mm	1159	1159	1159
	in	<b>45.6</b>	<b>45.6</b>	<b>45.6</b>
Carriage step additional width	mm	108	108	108
	in	<b>4.3</b>	<b>4.3</b>	<b>4.3</b>
Carriage height above blade top	mm	923.5	923.5	923.5
	in	<b>36.4</b>	<b>36.4</b>	<b>36.4</b>
Blade surface height at maximum height	mm	2754	2754	2754
	in	<b>108.4</b>	<b>108.4</b>	<b>108.4</b>
Shank front face reach at maximum height	mm	373	373	373
	in	<b>14.7</b>	<b>14.7</b>	<b>14.7</b>
Blade surface height at level lift arms	mm	1419	1419	1419
	in	<b>55.9</b>	<b>55.9</b>	<b>55.9</b>
Shank front face reach at level lift arms	mm	802	802	802
	in	<b>31.6</b>	<b>31.6</b>	<b>31.6</b>
Blade surface height at minimum lift	mm	106	106	106
	in	<b>4.2</b>	<b>4.2</b>	<b>4.2</b>
Shank front face reach at minimum lift	mm	392	392	392
	in	<b>15.4</b>	<b>15.4</b>	<b>15.4</b>
Overall length at minimum lift, level tine	mm	3601	3761	3911
	in	<b>142.0</b>	<b>148.0</b>	<b>154.0</b>
Tipping load	kg	1542	1436	1349
	lb	<b>3400</b>	<b>3167</b>	<b>2975</b>
Operating weight	kg	3134	3145	3154
	lb	<b>6911</b>	<b>6934</b>	<b>6955</b>

Bucket Type		General Purpose						Multi-Purpose		
		1680 mm (66")			1829 mm (72")			1680 mm (66")		
Bucket Width		Holes Only	Bolt-on Edge	Bolt-on Teeth	Holes Only	Bolt-on Edge	Bolt-on Teeth	Holes Only	Bolt-on Edge	
Ground Engaging Type										
Bucket Assembly No.		165-6153	152-0226	152-0225	165-6154	152-0229	152-0228	154-5008	154-5047	
Rated bucket capacity	m <sup>3</sup>	0.40	0.40	0.41	0.44	0.44	0.45	0.33	0.33	
	yd <sup>3</sup>	<b>0.52</b>	<b>0.52</b>	<b>0.53</b>	<b>0.57</b>	<b>0.57</b>	<b>0.59</b>	<b>0.43</b>	<b>0.43</b>	
Struck capacity	m <sup>3</sup>	0.29	0.29	0.29	0.32	0.32	0.32	0.24	0.25	
	yd <sup>3</sup>	<b>0.38</b>	<b>0.38</b>	<b>0.38</b>	<b>0.42</b>	<b>0.42</b>	<b>0.42</b>	<b>0.31</b>	<b>0.33</b>	
Width	mm	1730	1740	1730	1883	1893	1883	1749	1749	
	in	<b>68.0</b>	<b>68.0</b>	<b>68.0</b>	<b>74.0</b>	<b>75.0</b>	<b>74.0</b>	<b>69.0</b>	<b>69.0</b>	
Dump clearance at maximum lift/dump	mm	2278	2275	2201	2275	2244	2205	2274	2242	
	in	<b>89.7</b>	<b>89.6</b>	<b>86.7</b>	<b>89.6</b>	<b>88.3</b>	<b>86.8</b>	<b>89.5</b>	<b>88.3</b>	
Reach at maximum lift/dump	mm	790	797	853	790	798	854	793	801	
	in	<b>31.1</b>	<b>31.4</b>	<b>33.6</b>	<b>31.1</b>	<b>31.4</b>	<b>33.6</b>	<b>31.2</b>	<b>31.5</b>	
Floor angle at maximum lift/dump	degrees	<b>40.5°</b>	<b>40.5°</b>	<b>40.5°</b>	<b>40.5°</b>	<b>40.5°</b>	<b>40.5°</b>	<b>40.5°</b>	<b>40.5°</b>	
Floor angle at maximum lift/rack back	degrees	<b>86.9°</b>	<b>86.9°</b>	<b>86.9°</b>	<b>86.9°</b>	<b>86.9°</b>	<b>86.9°</b>	<b>86.9°</b>	<b>86.9°</b>	
Clearance at maximum lift/level bucket	mm	2889	2870	2885	2885	2870	2885	2887	2871	
	in	<b>113.7</b>	<b>113.0</b>	<b>113.6</b>	<b>113.6</b>	<b>113.0</b>	<b>113.6</b>	<b>113.7</b>	<b>113.0</b>	
Hinge pin height at maximum lift	mm	3081	3081	3081	3081	3081	3081	3081	3081	
	in	<b>121.3</b>	<b>121.3</b>	<b>121.3</b>	<b>121.3</b>	<b>121.3</b>	<b>121.3</b>	<b>121.3</b>	<b>121.3</b>	
Maximum overall height	mm	3963	3990	4060	3963	3990	4060	3966	3994	
	in	<b>156.0</b>	<b>157.1</b>	<b>159.8</b>	<b>156.0</b>	<b>157.1</b>	<b>159.8</b>	<b>156.1</b>	<b>157.2</b>	
Reach at level lift arm/bucket	mm	1387	1415	1484	1388	1416	1486	1391	1419	
	in	<b>54.6</b>	<b>55.7</b>	<b>58.4</b>	<b>54.6</b>	<b>55.7</b>	<b>58.5</b>	<b>54.8</b>	<b>55.9</b>	
Maximum floor angle at minimum lift	degrees	<b>25.4°</b>	<b>25.4°</b>	<b>25.4°</b>	<b>25.4°</b>	<b>25.4°</b>	<b>25.4°</b>	<b>25.3°</b>	<b>25.3°</b>	
Dig depth with level bucket	mm	0	0	0	0	0	0	0	0	
	in	<b>0.0</b>	<b>0.0</b>	<b>0.0</b>	<b>0.0</b>	<b>0.0</b>	<b>0.0</b>	<b>0.0</b>	<b>0.0</b>	
Overall length with bucket on ground	mm	3490	3518	3588	3491	3519	3588	3494	3522	
	in	<b>137.4</b>	<b>138.5</b>	<b>141.3</b>	<b>137.4</b>	<b>138.5</b>	<b>141.3</b>	<b>137.6</b>	<b>138.7</b>	
Front clearance circle radius (with bucket)	mm	2261	2293	2327	2292	2323	2354	2250	2282	
	in	<b>89.0</b>	<b>90.3</b>	<b>91.6</b>	<b>90.2</b>	<b>91.5</b>	<b>92.7</b>	<b>88.6</b>	<b>89.8</b>	
Tipping load	257B2	kg	2266	2204	2244	2264	2198	2242	2117	2058
		lb	<b>4997</b>	<b>4860</b>	<b>4947</b>	<b>4992</b>	<b>4847</b>	<b>4943</b>	<b>4668</b>	<b>4538</b>
Breakout force — lift	257B2 HF	kg	2202	2140	2179	2200	2135	2177	2054	1995
		lb	<b>4855</b>	<b>4719</b>	<b>4805</b>	<b>4850</b>	<b>4707</b>	<b>4801</b>	<b>4528</b>	<b>4399</b>
Breakout force — lift	257B2	kg	1683	1632	1667	1682	1629	1666	1576	1526
		lb	<b>3712</b>	<b>3599</b>	<b>3676</b>	<b>3709</b>	<b>3592</b>	<b>3674</b>	<b>3474</b>	<b>3365</b>
Breakout force — lift	257B2 HF	kg	1671	1621	1655	1670	1617	1654	1564	1514
		lb	<b>3685</b>	<b>3573</b>	<b>3650</b>	<b>3682</b>	<b>3565</b>	<b>3648</b>	<b>3448</b>	<b>3339</b>
Breakout force — tilt	257B2	kg	1646	1543	1628	1644	1540	1628	1573	1474
		lb	<b>3629</b>	<b>3403</b>	<b>3590</b>	<b>3625</b>	<b>3397</b>	<b>3589</b>	<b>3469</b>	<b>3251</b>
Breakout force — tilt	257B2 HF	kg	1646	1543	1628	1644	1540	1628	1573	1474
		lb	<b>3629</b>	<b>3403</b>	<b>3590</b>	<b>3625</b>	<b>3397</b>	<b>3589</b>	<b>3469</b>	<b>3251</b>
Operating weight	257B2	kg	3624	3657	3641	3626	3661	3642	3751	3783
		lb	<b>7991</b>	<b>8064</b>	<b>8027</b>	<b>7994</b>	<b>8073</b>	<b>8030</b>	<b>8270</b>	<b>8342</b>
Operating weight	257B2 HF	kg	3666	3699	3682	3667	3703	3683	3792	3825
		lb	<b>8083</b>	<b>8155</b>	<b>8119</b>	<b>8086</b>	<b>8164</b>	<b>8122</b>	<b>8362</b>	<b>8434</b>

HF = High Lift



Bucket Type		Multi-Purpose				Dirt				
		1680 mm (66")		1829 mm (72")		1680 mm (66")		1829 mm (72")		
Bucket Width		1680 mm (66")		1829 mm (72")		1680 mm (66")		1829 mm (72")		
Ground Engaging Type		Bolt-on Teeth	Holes Only	Bolt-on Edge	Bolt-on Teeth	Holes Only	Bolt-on Edge	Holes Only	Bolt-on Edge	
Bucket Assembly No.		154-5048	154-5010	154-5049	154-5050	165-6157	152-0232	188-3526	188-2719	
Rated bucket capacity	m <sup>3</sup>	0.34	0.37	0.37	0.37	0.37	0.38	0.41	0.42	
	yd <sup>3</sup>	<b>0.44</b>	<b>0.48</b>	<b>0.48</b>	<b>0.48</b>	<b>0.48</b>	<b>0.49</b>	<b>0.54</b>	<b>0.55</b>	
Struck capacity	m <sup>3</sup>	0.24	0.27	0.28	0.27	0.27	0.27	0.29	0.31	
	yd <sup>3</sup>	<b>0.31</b>	<b>0.35</b>	<b>0.36</b>	<b>0.35</b>	<b>0.35</b>	<b>0.35</b>	<b>0.38</b>	<b>0.41</b>	
Width	mm	1749	1902	1902	1902	1730	1740	1883	1893	
	in	<b>69.0</b>	<b>75.0</b>	<b>75.0</b>	<b>75.0</b>	<b>68.0</b>	<b>69.0</b>	<b>74.0</b>	<b>75.0</b>	
Dump clearance at maximum lift/dump	mm	2199	2274	2242	2199	2318	2288	2316	2285	
	in	<b>86.6</b>	<b>89.5</b>	<b>88.3</b>	<b>86.6</b>	<b>91.3</b>	<b>90.1</b>	<b>91.2</b>	<b>90.0</b>	
Reach at maximum lift/dump	mm	856	793	801	856	756	763	756	763	
	in	<b>33.7</b>	<b>31.2</b>	<b>31.5</b>	<b>33.7</b>	<b>29.8</b>	<b>30.0</b>	<b>29.8</b>	<b>30.0</b>	
Floor angle at maximum lift/dump	degrees	<b>40.5°</b>	<b>40.5°</b>	<b>40.5°</b>	<b>40.5°</b>	<b>40.5°</b>	<b>40.5°</b>	<b>40.5°</b>	<b>40.5°</b>	
Floor angle at maximum lift/rack back	degrees	<b>86.9°</b>	<b>86.9°</b>	<b>86.9°</b>	<b>86.9°</b>	<b>86.9°</b>	<b>86.9°</b>	<b>86.9°</b>	<b>86.9°</b>	
Clearance at maximum lift/level bucket	mm	2886	2887	2871	2886	2885	2869	2885	2869	
	in	<b>113.6</b>	<b>113.7</b>	<b>113.0</b>	<b>113.6</b>	<b>113.6</b>	<b>113.0</b>	<b>113.6</b>	<b>113.0</b>	
Hinge pin height at maximum lift	mm	3081	3081	3081	3081	3081	3081	3081	3081	
	in	<b>121.3</b>	<b>121.3</b>	<b>121.3</b>	<b>121.3</b>	<b>121.3</b>	<b>121.3</b>	<b>121.3</b>	<b>121.3</b>	
Maximum overall height	mm	4064	3966	3994	4064	3910	3937	3910	3937	
	in	<b>160.0</b>	<b>156.1</b>	<b>157.2</b>	<b>160.0</b>	<b>153.9</b>	<b>155.0</b>	<b>153.9</b>	<b>155.0</b>	
Reach at level lift arm/bucket	mm	1489	1391	1419	1489	1334	1362	1334	1362	
	in	<b>58.6</b>	<b>54.8</b>	<b>55.9</b>	<b>58.6</b>	<b>52.5</b>	<b>53.6</b>	<b>52.5</b>	<b>53.6</b>	
Maximum floor angle at minimum lift	degrees	<b>25.3°</b>	<b>25.3°</b>	<b>25.3°</b>	<b>25.3°</b>	<b>25.4°</b>	<b>25.4°</b>	<b>25.4°</b>	<b>25.4°</b>	
Dig depth with level bucket	mm	0	0	0	0	0	0	0	0	
	in	<b>0.0</b>	<b>0.0</b>	<b>0.0</b>	<b>0.0</b>	<b>0.0</b>	<b>0.0</b>	<b>0.0</b>	<b>0.0</b>	
Overall length with bucket on ground	mm	3591	3494	3522	3591	3437	3465	3437	3465	
	in	<b>141.4</b>	<b>137.6</b>	<b>138.7</b>	<b>141.4</b>	<b>135.3</b>	<b>136.4</b>	<b>135.3</b>	<b>136.4</b>	
Front clearance circle radius (with bucket)	mm	2317	2281	2312	2344	2205	2237	2236	2268	
	in	<b>91.2</b>	<b>89.8</b>	<b>91.0</b>	<b>92.3</b>	<b>86.8</b>	<b>88.1</b>	<b>88.0</b>	<b>89.3</b>	
Tipping load	257B2	kg	2098	2099	2037	2079	2386	2317	2378	2306
		lb	<b>4626</b>	<b>4629</b>	<b>4491</b>	<b>4585</b>	<b>5260</b>	<b>5109</b>	<b>5244</b>	<b>5084</b>
	257B2 HF	kg	2034	2036	1974	2016	2320	2252	2312	2240
		lb	<b>4486</b>	<b>4489</b>	<b>4352</b>	<b>4445</b>	<b>5115</b>	<b>4965</b>	<b>5099</b>	<b>4940</b>
Breakout force — lift	257B2	kg	1560	1561	1509	1545	1761	1709	1755	1700
		lb	<b>3439</b>	<b>3441</b>	<b>3326</b>	<b>3406</b>	<b>3883</b>	<b>3769</b>	<b>3869</b>	<b>3749</b>
	257B2 HF	kg	1548	1549	1497	1533	1749	1697	1743	1688
		lb	<b>3413</b>	<b>3415</b>	<b>3300</b>	<b>3380</b>	<b>3857</b>	<b>3743</b>	<b>3842</b>	<b>3722</b>
Breakout force — tilt	257B2	kg	1556	1564	1466	1549	1793	1680	1790	1674
		lb	<b>3430</b>	<b>3450</b>	<b>3232</b>	<b>3416</b>	<b>3954</b>	<b>3705</b>	<b>3946</b>	<b>3691</b>
	257B2 HF	kg	1556	1564	1466	1549	1793	1680	1790	1674
		lb	<b>3430</b>	<b>3450</b>	<b>3232</b>	<b>3416</b>	<b>3954</b>	<b>3705</b>	<b>3946</b>	<b>3691</b>
Operating weight	257B2	kg	3767	3769	3805	3786	3568	3600	3575	3611
		lb	<b>8306</b>	<b>8311</b>	<b>8390</b>	<b>8347</b>	<b>7866</b>	<b>7939</b>	<b>7884</b>	<b>7962</b>
	257B2 HF	kg	3808	3811	3847	3827	3609	3642	3617	3653
		lb	<b>8398</b>	<b>8402</b>	<b>8482</b>	<b>8439</b>	<b>7958</b>	<b>8030</b>	<b>7975</b>	<b>8054</b>

HF = High Flow

Work Tool			Pallet Fork		
			910 mm (36")	1070 mm (42")	1220 mm (48")
<b>Tine Length</b>					
<b>Carriage Assembly No.</b>			<b>242-9998</b>	<b>242-9999</b>	<b>243-0000</b>
Carriage overall width without step	mm		1159	1159	1159
	in		<b>45.6</b>	<b>45.6</b>	<b>45.6</b>
Carriage step additional width	mm		108	108	108
	in		<b>4.3</b>	<b>4.3</b>	<b>4.3</b>
Carriage height above blade top	mm		923.5	923.5	923.5
	in		<b>36.4</b>	<b>36.4</b>	<b>36.4</b>
Blade surface height at maximum height	mm		2968	2968	2988
	in		<b>116.9</b>	<b>116.9</b>	<b>117.6</b>
Shank front face reach at maximum height	mm		655	655	655
	in		<b>25.8</b>	<b>25.8</b>	<b>25.8</b>
Blade surface height at level lift arms	mm		1554	1554	1554
	in		<b>61.2</b>	<b>61.2</b>	<b>61.2</b>
Shank front face reach at level lift arms	mm		793	793	793
	in		<b>31.2</b>	<b>31.2</b>	<b>31.2</b>
Blade surface height at minimum lift	mm		112	112	112
	in		<b>4.4</b>	<b>4.4</b>	<b>4.4</b>
Shank front face reach at minimum lift	mm		500	500	500
	in		<b>19.7</b>	<b>19.7</b>	<b>19.7</b>
Overall length at minimum lift, level tine	mm		3806	3966	4116
	ft/in		<b>12'6"</b>	<b>13'0"</b>	<b>13'6"</b>
Tipping load	257B2	kg	1931	1805	1701
		lb	<b>4258</b>	<b>3980</b>	<b>3750</b>
	257B2 HF	kg	1878	1755	1653
		lb	<b>4141</b>	<b>3870</b>	<b>3646</b>
Operating weight	257B2	kg	3583	3594	3414
		lb	<b>7901</b>	<b>7924</b>	<b>7528</b>
	257B2 HF	kg	3625	3635	3645
		lb	<b>7993</b>	<b>8016</b>	<b>8037</b>

HF = High Flow

Bucket Type		General Purpose			High Capacity — GP			Multi-Purpose	
Bucket Width		1981 mm (78")			2134 mm (84")			1981 mm (78")	
Ground Engaging Type		Holes Only	Bolt-on Edge	Bolt-on Teeth	Holes Only	Bolt-on Edge	Bolt-on Teeth	Holes Only	Bolt-on Edge
Bucket Assembly No.		279-5376	279-5377	279-5378	292-9271	296-8192	296-8191	279-5403	279-5402
Rated bucket capacity	m <sup>3</sup>	0.47	0.49	0.47	0.63	0.63	0.63	0.40	0.42
	yd <sup>3</sup>	<b>0.61</b>	<b>0.64</b>	<b>0.61</b>	<b>0.82</b>	<b>0.82</b>	<b>0.82</b>	<b>0.52</b>	<b>0.55</b>
Struck capacity	m <sup>3</sup>	0.34	0.34	0.34	0.59	0.59	0.59	0.28	0.28
	yd <sup>3</sup>	<b>0.44</b>	<b>0.44</b>	<b>0.44</b>	<b>0.77</b>	<b>0.77</b>	<b>0.77</b>	<b>0.37</b>	<b>0.37</b>
Width	mm	2035	2045	2035	2187	2198	2187	2035	2045
	in	<b>80.1</b>	<b>80.5</b>	<b>80.1</b>	<b>86.1</b>	<b>86.5</b>	<b>86.1</b>	<b>80.1</b>	<b>80.5</b>
Dump clearance at maximum lift/dump	mm	2385	2355	2385	2324.1	2324.1	2324	2378	2348
	in	<b>93.9</b>	<b>92.7</b>	<b>93.9</b>	<b>91.5</b>	<b>91.5</b>	<b>91.5</b>	<b>93.6</b>	<b>92.4</b>
Reach at maximum lift/dump	mm	652	663	652	722.4	722.4	722	656	666
	in	<b>25.7</b>	<b>26.1</b>	<b>25.7</b>	<b>28.4</b>	<b>28.4</b>	<b>28.4</b>	<b>25.8</b>	<b>26.2</b>
Floor angle at maximum lift/dump	degrees	40°	40°	40°	40°	40°	40°	40°	40°
Floor angle at maximum lift/rack back	degrees	85°	85°	85°	96°	96°	96°	85°	85°
Clearance at maximum lift/level bucket	mm	2928	2912	2928	2928	2912	2928	2925	2908
	in	<b>115.3</b>	<b>114.6</b>	<b>115.3</b>	<b>115.3</b>	<b>114.6</b>	<b>115.3</b>	<b>115.2</b>	<b>114.5</b>
Hinge pin height at maximum lift	mm	3122	3122	3122	3122	3122	3122	3122	3122
	in	<b>122.9</b>	<b>122.9</b>	<b>122.9</b>	<b>122.9</b>	<b>122.9</b>	<b>122.9</b>	<b>122.9</b>	<b>122.9</b>
Maximum overall height	mm	4051	4079	4149	4051	4079	4149	4055	4083
	in	<b>159.5</b>	<b>160.6</b>	<b>163.3</b>	<b>159.5</b>	<b>160.6</b>	<b>163.3</b>	<b>159.6</b>	<b>160.7</b>
Reach at level lift arm/bucket	mm	1452	1480	1550	1452	1480	1550	1462	1490
	in	<b>57.2</b>	<b>58.3</b>	<b>61.0</b>	<b>57.2</b>	<b>58.3</b>	<b>61.0</b>	<b>57.6</b>	<b>58.7</b>
Maximum floor angle at minimum lift	degrees	26.4°	26.4°	26.4°	26.4°	26.4°	26.4°	26.4°	26.4°
Dig depth with level bucket	mm	11	27	11	11	11	11	16	33
	in	<b>0.4</b>	<b>1.1</b>	<b>0.4</b>	<b>0.4</b>	<b>0.4</b>	<b>0.4</b>	<b>0.6</b>	<b>1.3</b>
Overall length with bucket on ground	mm	3766	3794	3863	3838	3860	3935	3768	3796
	in	<b>148.3</b>	<b>149.4</b>	<b>152.1</b>	<b>151.1</b>	<b>152.0</b>	<b>154.9</b>	<b>148.3</b>	<b>149.4</b>
Front clearance circle radius (with bucket)	mm	2549	2581	2612	2577	2609	2640	2550	2582
	in	<b>100.4</b>	<b>101.6</b>	<b>102.8</b>	<b>101.5</b>	<b>102.7</b>	<b>103.9</b>	<b>100.4</b>	<b>101.7</b>
Tipping load	kg	3026	2954	3002	2721	2651	2697	2862	2791
	lb	<b>6671</b>	<b>6512</b>	<b>6618</b>	<b>5999</b>	<b>5844</b>	<b>5946</b>	<b>6310</b>	<b>6153</b>
Breakout force — lift	kg	2629	2563	2611	2517	2449	2500	2503	2438
	lb	<b>5796</b>	<b>5650</b>	<b>5756</b>	<b>5549</b>	<b>5399</b>	<b>5512</b>	<b>5518</b>	<b>5375</b>
Breakout force — tilt	kg	3086	2923	3067	2743	2602	2724	2989	2830
	lb	<b>6803</b>	<b>6444</b>	<b>6762</b>	<b>6047</b>	<b>5736</b>	<b>6005</b>	<b>6590</b>	<b>6239</b>
Operating weight	kg	4287	4324	4305	4313	4355	4331	4433	4470
	lb	<b>9451</b>	<b>9533</b>	<b>9491</b>	<b>9509</b>	<b>9601</b>	<b>9548</b>	<b>9773</b>	<b>9855</b>

Bucket Type	Multi-Purpose				Dirt		
	1981 mm (78")	2134 mm (84")			1981 mm (78")		
Bucket Width							
Ground Engaging Type	Bolt-on Teeth	Holes Only	Bolt-on Edge	Bolt-on Teeth	Holes Only	Bolt-on Edge	
Bucket Assembly No.	279-5401	293-0139	296-8057	296-8055	268-4084	268-4083	
Rated bucket capacity	m <sup>3</sup> yd <sup>3</sup>	0.40 0.52	0.43 0.56	0.43 0.56	0.43 0.56	0.44 0.58	0.45 0.59
Struck capacity	m <sup>3</sup> yd <sup>3</sup>	0.28 0.37	0.30 0.39	0.30 0.39	0.30 0.39	0.32 0.42	0.32 0.42
Width	mm in	2035 80.1	2187 86.1	2198 86.5	2187 86.1	1981 78.0	1991 78.4
Dump clearance at maximum lift/dump	mm in	2378 93.6	2378.4 93.6	2348 92.4	2378.4 93.6	2421 95.3	2391 94.1
Reach at maximum lift/dump	mm in	656 25.8	655.5 25.8	666.5 26.2	655.5 25.8	613 24.1	624 24.6
Floor angle at maximum lift/dump	degrees	40°	40°	40°	40°	40°	40°
Floor angle at maximum lift/rack back	degrees	85°	96°	96°	96°	85°	85°
Clearance at maximum lift/level bucket	mm in	2925 115.2	2925 115.2	2908 114.5	2925 115.2	2930 115.4	2914 114.7
Hinge pin height at maximum lift	mm in	3122 122.9	3122 122.9	3122 122.9	3122 122.9	3233 127.3	3233 127.3
Maximum overall height	mm in	4153 163.5	4055 159.6	4083 160.7	4153 163.5	3998 157.4	4026 158.5
Reach at level lift arm/bucket	mm in	1560 61.4	1462 57.6	1490 58.7	1560 61.4	1402 55.2	1430 56.3
Maximum floor angle at minimum lift	degrees	26.4°	26.4°	26.4°	26.4°	26.4°	26.4°
Dig depth with level bucket	mm in	16 0.6	11 0.4	11 0.4	11 0.4	11 0.4	27 1.1
Overall length with bucket on ground	mm in	3866 152.2	3753 147.8	3780 148.8	3850 151.6	3715 146.3	3743 147.4
Front clearance circle radius (with bucket)	mm in	2613 102.9	2578 101.5	2610 102.8	2641 104.0	2508 98.7	2540 100.0
Tipping load	kg lb	2838 6257	2633 5805	2560 5644	2609 5752	3138 6918	3052 6728
Breakout force — lift	kg lb	2485 5478	2485 5478	2416 5326	2467 5439	2696 5944	2626 5789
Breakout force — tilt	kg lb	2969 6545	2979 6568	2817 6210	2959 6523	3314 7306	3129 6898
Operating weight	kg lb	4451 9813	4447 9804	4489 9897	4465 9844	4265 9403	4305 9491

<b>Work Tool</b>		<b>Pallet Fork</b>		
		<b>910 mm (36")</b>	<b>1070 mm (42")</b>	<b>1220 mm (48")</b>
<b>Tine Length</b>				
<b>Carriage Assembly No.</b>		<b>293-9427</b>	<b>293-9428</b>	<b>293-9429</b>
Carriage overall width without step	<b>mm</b>	1159	1159	1159
	<b>in</b>	<b>45.6</b>	<b>45.6</b>	<b>45.6</b>
Carriage step additional width	<b>mm</b>	106	106	106
	<b>in</b>	<b>4.2</b>	<b>4.2</b>	<b>4.2</b>
Carriage height above blade top	<b>mm</b>	930	930	930
	<b>in</b>	<b>36.6</b>	<b>36.6</b>	<b>36.6</b>
Blade surface height at maximum height	<b>mm</b>	3019	3019	3019
	<b>in</b>	<b>118.9</b>	<b>118.9</b>	<b>118.9</b>
Shank front face reach at maximum height	<b>mm</b>	389	389	389
	<b>in</b>	<b>15.3</b>	<b>15.3</b>	<b>15.3</b>
Blade surface height at level lift arms	<b>mm</b>	1608	1608	1608
	<b>in</b>	<b>63.3</b>	<b>63.3</b>	<b>63.3</b>
Shank front face reach at level lift arms	<b>mm</b>	751	751	751
	<b>in</b>	<b>29.6</b>	<b>29.6</b>	<b>29.6</b>
Blade surface height at minimum lift	<b>mm</b>	148	148	148
	<b>in</b>	<b>5.8</b>	<b>5.8</b>	<b>5.8</b>
Shank front face reach at minimum lift	<b>mm</b>	428	428	428
	<b>in</b>	<b>16.9</b>	<b>16.9</b>	<b>16.9</b>
Overall length at minimum lift, level tine	<b>mm</b>	4079	4079	4079
	<b>in</b>	<b>160.6</b>	<b>160.6</b>	<b>160.6</b>
Tipping load	<b>kg</b>	2457	2335	2229
	<b>lb</b>	<b>5417</b>	<b>5148</b>	<b>4914</b>
Operating weight	<b>kg</b>	4203	4213	4223
	<b>lb</b>	<b>9266</b>	<b>9288</b>	<b>9310</b>

Bucket Type		General Purpose			High Capacity — GP			Multi-Purpose	
Bucket Width		1981 mm (78")			2134 mm (84")			1981 mm (78")	
Ground Engaging Type		Holes Only	Bolt-on Edge	Bolt-on Teeth	Holes Only	Bolt-on Edge	Bolt-on Teeth	Holes Only	Bolt-on Edge
Bucket Assembly No.		279-5376	279-5377	279-5378	292-9271	296-8192	296-8191	279-5403	279-5402
Rated bucket capacity	m <sup>3</sup>	0.47	0.49	0.47	0.63	0.63	0.63	0.40	0.42
	yd <sup>3</sup>	<b>0.61</b>	<b>0.64</b>	<b>0.61</b>	<b>0.82</b>	<b>0.82</b>	<b>0.82</b>	<b>0.52</b>	<b>0.55</b>
Struck capacity	m <sup>3</sup>	0.34	0.34	0.34	0.59	0.59	0.59	0.28	0.28
	yd <sup>3</sup>	<b>0.44</b>	<b>0.44</b>	<b>0.44</b>	<b>0.77</b>	<b>0.77</b>	<b>0.77</b>	<b>0.37</b>	<b>0.37</b>
Width	mm	2035	2045	2035	2187	2198	2187	2035	2045
	in	<b>80.1</b>	<b>80.5</b>	<b>80.1</b>	<b>86.1</b>	<b>86.5</b>	<b>86.1</b>	<b>80.1</b>	<b>80.5</b>
Dump clearance at maximum lift/dump	mm	2496	2466	2496	2335	2304	2333	2489	2458
	in	<b>98.3</b>	<b>97.1</b>	<b>98.3</b>	<b>91.9</b>	<b>90.7</b>	<b>91.9</b>	<b>98.0</b>	<b>96.8</b>
Reach at maximum lift/dump	mm	800	814	849	891	897	894	971	982
	in	<b>31.5</b>	<b>32.0</b>	<b>33.4</b>	<b>35.1</b>	<b>35.3</b>	<b>35.2</b>	<b>38.2</b>	<b>38.7</b>
Floor angle at maximum lift/dump	degrees	40°	40°	40°	50°	50°	50°	40°	40°
Floor angle at maximum lift/rack back	degrees	85°	85°	85°	85°	85°	85°	85°	85°
Clearance at maximum lift/level bucket	mm	3043	3043	3043	3039	3023	3039	3043	3043
	in	<b>119.8</b>	<b>119.8</b>	<b>119.8</b>	<b>119.6</b>	<b>119.0</b>	<b>119.6</b>	<b>119.8</b>	<b>119.8</b>
Hinge pin height at maximum lift	mm	3233	3233	3233	3233	3233	3233	3233	3233
	in	<b>127.3</b>	<b>127.3</b>	<b>127.3</b>	<b>127.3</b>	<b>127.3</b>	<b>127.3</b>	<b>127.3</b>	<b>127.3</b>
Maximum overall height	mm	4075	4089	4124	4221	4247	4319	4075	4089
	in	<b>160.4</b>	<b>161.0</b>	<b>162.4</b>	<b>166.2</b>	<b>167.2</b>	<b>170.0</b>	<b>160.4</b>	<b>161.0</b>
Reach at level lift arm/bucket	mm	1301	1330	1399	1447	1475	1545	1301	1330
	in	<b>51.2</b>	<b>52.4</b>	<b>55.1</b>	<b>57.0</b>	<b>58.1</b>	<b>60.8</b>	<b>51.2</b>	<b>52.4</b>
Maximum floor angle at minimum lift	degrees	26.4°	26.4°	26.4°	26.4°	26.4°	26.4°	26.4°	26.4°
Dig depth with level bucket	mm	11	27	11	11	27	11	16	33
	in	<b>0.4</b>	<b>1.1</b>	<b>0.4</b>	<b>0.4</b>	<b>1.1</b>	<b>0.4</b>	<b>0.6</b>	<b>1.3</b>
Overall length with bucket on ground	mm	3692	3720	3790	3838	3866	3935	3745	3773
	in	<b>145.4</b>	<b>146.5</b>	<b>149.2</b>	<b>151.1</b>	<b>152.2</b>	<b>154.9</b>	<b>147.4</b>	<b>148.5</b>
Front clearance circle radius (with bucket)	mm	2580	2611	2643	2608	2639	2671	2581	2613
	in	<b>101.6</b>	<b>102.8</b>	<b>104.1</b>	<b>102.7</b>	<b>103.9</b>	<b>105.2</b>	<b>101.6</b>	<b>102.9</b>
Tipping load	kg	3504	3426	3480	3264	3188	3240	3333	3256
	lb	<b>7725</b>	<b>7553</b>	<b>7672</b>	<b>7196</b>	<b>7028</b>	<b>7143</b>	<b>7348</b>	<b>7178</b>
Breakout force — lift	kg	2408	2347	2391	2309	2245	2291	2281	2222
	lb	<b>5309</b>	<b>5174</b>	<b>5271</b>	<b>5090</b>	<b>4949</b>	<b>5051</b>	<b>5029</b>	<b>4899</b>
Breakout force — tilt	kg	3086	2923	3067	2743	2602	2724	2988	2830
	lb	<b>6803</b>	<b>6444</b>	<b>6762</b>	<b>6047</b>	<b>5736</b>	<b>6005</b>	<b>6587</b>	<b>6239</b>
Operating weight	kg	4515	4552	4533	4533	4575	4551	4662	4699
	lb	<b>9954</b>	<b>10,035</b>	<b>9994</b>	<b>9994</b>	<b>10,086</b>	<b>10,033</b>	<b>10,278</b>	<b>10,359</b>

Bucket Type	Multi-Purpose				Dirt	
Bucket Width	1981 mm (78")	2134 mm (84")		1981 mm (78")		
Ground Engaging Type	Bolt-on Teeth	Holes Only	Bolt-on Edge	Bolt-on Teeth	Holes Only	Bolt-on Edge
Bucket Assembly No.	279-5401	293-0139	296-8057	296-8055	268-4084	268-4083
Rated bucket capacity	m <sup>3</sup> yd <sup>3</sup> 0.40 0.52	0.43 0.56	0.43 0.56	0.43 0.56	0.44 0.58	0.45 0.59
Struck capacity	m <sup>3</sup> yd <sup>3</sup> 0.28 0.37	0.30 0.39	0.30 0.39	0.30 0.39	0.32 0.42	0.32 0.42
Width	mm in 2035 80.1	2187 86.1	2198 86.5	2187 86.1	1981 78.0	1991 78.4
Dump clearance at maximum lift/dump	mm in 2489 98.0	2400 94.5	2368 93.2	2325 91.5	2450 96.5	2419 95.2
Reach at maximum lift/dump	mm in 971 38.2	834 32.8	840 33.1	896 35.3	800 31.5	814 32.0
Floor angle at maximum lift/dump	degrees 40°	50°	50°	50°	40°	40°
Floor angle at maximum lift/rack back	degrees 85°	85°	85°	85°	85°	85°
Clearance at maximum lift/level bucket	mm in 3043 119.8	3036 119.5	3019 118.9	3034 119.4	3043 119.8	3043 119.8
Hinge pin height at maximum lift	mm in 3233 127.3	3233 127.3	3233 127.3	3233 127.3	3233 127.3	3233 127.3
Maximum overall height	mm in 4124 162.4	4135 162.8	4161 163.8	4232 166.6	4075 160.4	4089 161.0
Reach at level lift arm/bucket	mm in 1399 55.1	1361 53.6	1389 54.7	1459 57.4	1301 51.2	1330 52.4
Maximum floor angle at minimum lift	degrees 26.4°	26.4°	26.4°	26.4°	26.4°	26.4°
Dig depth with level bucket	mm in 16 0.6	16 0.6	16 0.6	16 0.6	11 0.4	27 1.1
Overall length with bucket on ground	mm in 3843 151.3	3745 147.4	3773 148.5	3843 151.3	3692 145.4	3720 146.5
Front clearance circle radius (with bucket)	mm in 2645 104.1	2609 101.6	2641 102.9	2646 104.1	2538 99.9	2570 101.2
Tipping load	kg lb 3309 7295	3185 7022	3105 6845	3160 6967	3634 8012	3539 7802
Breakout force — lift	kg lb 2264 4991	2262 4987	2198 4846	2245 4949	2468 5441	2402 5295
Breakout force — tilt	kg lb 2969 6545	2979 6568	2817 6210	2959 6523	3314 7306	3129 6898
Operating weight	kg lb 4680 10,318	4666 10,287	4708 10,379	4684 10,326	4493 9905	4533 9994

Work Tool	Pallet Fork			
		910 mm (36")	1070 mm (42")	1220 mm (48")
<b>Tine Length</b>				
<b>Carriage Assembly No.</b>		<b>293-9427</b>	<b>293-9428</b>	<b>293-9429</b>
Carriage overall width without step	mm in	1159 <b>45.6</b>	1160 <b>45.7</b>	1161 <b>45.7</b>
Carriage step additional width	mm in	106 <b>4.2</b>	107 <b>4.2</b>	108 <b>4.3</b>
Carriage height above blade top	mm in	930 <b>36.6</b>	931 <b>36.7</b>	932 <b>36.7</b>
Blade surface height at maximum height	mm in	3130 <b>123.2</b>	3131 <b>123.3</b>	3132 <b>123.3</b>
Shank front face reach at maximum height	mm in	703 <b>27.7</b>	704 <b>27.7</b>	705 <b>27.8</b>
Blade surface height at level lift arms	mm in	1608 <b>63.3</b>	1609 <b>63.3</b>	1610 <b>63.4</b>
Shank front face reach at level lift arms	mm in	751 <b>29.6</b>	752 <b>29.6</b>	753 <b>29.6</b>
Blade surface height at minimum lift	mm in	90 <b>3.5</b>	91 <b>3.6</b>	92 <b>3.6</b>
Shank front face reach at minimum lift	mm in	425 <b>16.7</b>	426 <b>16.8</b>	427 <b>16.8</b>
Overall length at minimum lift, level tine	mm in	4065 <b>160.0</b>	4066 <b>160.1</b>	4067 <b>160.1</b>
Tippling load	kg lb	2822 <b>6221</b>	2678 <b>5904</b>	2555 <b>5633</b>
Operating weight	kg lb	4451 <b>9813</b>	4451 <b>9813</b>	4451 <b>9813</b>



Bucket Type		General Purpose			High Capacity — GP			Multi-Purpose	
Bucket Width		1981 mm (78")			2134 mm (84")			1981 mm (78")	
Ground Engaging Type		Holes Only	Bolt-on Edge	Bolt-on Teeth	Holes Only	Bolt-on Edge	Bolt-on Teeth	Holes Only	Bolt-on Edge
Bucket Assembly No.		279-5376	279-5377	279-5378	292-9271	296-8192	296-8191	279-5403	279-5402
Rated bucket capacity	m <sup>3</sup>	0.47	0.49	0.47	0.63	0.63	0.63	0.40	0.42
	yd <sup>3</sup>	<b>0.61</b>	<b>0.64</b>	<b>0.61</b>	<b>0.82</b>	<b>0.82</b>	<b>0.82</b>	<b>0.52</b>	<b>0.55</b>
Struck capacity	m <sup>3</sup>	0.40	0.34	0.34	0.59	0.59	0.59	0.28	0.28
	yd <sup>3</sup>	<b>0.52</b>	<b>0.44</b>	<b>0.44</b>	<b>0.77</b>	<b>0.77</b>	<b>0.77</b>	<b>0.37</b>	<b>0.37</b>
Width	mm	2035	2045	2035	2187	2198	2187	2035	2045
	in	<b>80.1</b>	<b>80.5</b>	<b>80.1</b>	<b>86.1</b>	<b>86.5</b>	<b>86.1</b>	<b>80.1</b>	<b>80.5</b>
Dump clearance at maximum lift/dump	mm	2444	2412	2367	2370	2338	2367	2536	2506
	in	<b>96.2</b>	<b>95.0</b>	<b>93.2</b>	<b>93.3</b>	<b>92.0</b>	<b>93.2</b>	<b>99.8</b>	<b>98.7</b>
Reach at maximum lift/dump	mm	814	819	874	871	876	874	974	985
	in	<b>32.0</b>	<b>32.2</b>	<b>34.4</b>	<b>34.3</b>	<b>34.5</b>	<b>34.4</b>	<b>38.3</b>	<b>38.8</b>
Floor angle at maximum lift/dump	degrees	51°	51°	51°	51°	51°	51°	40°	40°
Floor angle at maximum lift/rack back	degrees	83°	83°	83°	83°	83°	83°	85°	85°
Clearance at maximum lift/level bucket	mm	3086	3070	3086	3086	3070	3086	3043	3043
	in	<b>121.5</b>	<b>120.9</b>	<b>121.5</b>	<b>121.5</b>	<b>120.9</b>	<b>121.5</b>	<b>119.8</b>	<b>119.8</b>
Hinge pin height at maximum lift	mm	3280	3280	3280	3280	3280	3280	3233	3233
	in	<b>129.1</b>	<b>129.1</b>	<b>129.1</b>	<b>129.1</b>	<b>129.1</b>	<b>129.1</b>	<b>127.3</b>	<b>127.3</b>
Maximum overall height	mm	4168	4194	4265	4260	4286	4265	4075	4089
	in	<b>164.1</b>	<b>165.1</b>	<b>167.9</b>	<b>167.7</b>	<b>168.7</b>	<b>167.9</b>	<b>160.4</b>	<b>161.0</b>
Reach at level lift arm/bucket	mm	1341	1369	1439	1434	1462	1439	1301	1330
	in	<b>52.8</b>	<b>53.9</b>	<b>56.7</b>	<b>56.5</b>	<b>57.6</b>	<b>56.7</b>	<b>51.2</b>	<b>52.4</b>
Maximum floor angle at minimum lift	degrees	26.4°	26.4°	26.4°	26.4°	26.4°	26.4°	26.4°	26.4°
Dig depth with level bucket	mm	11	27	11	11	11	11	16	33
	in	<b>0.4</b>	<b>1.1</b>	<b>0.4</b>	<b>0.4</b>	<b>0.4</b>	<b>0.4</b>	<b>0.6</b>	<b>1.3</b>
Overall length with bucket on ground	mm	3886	3914	3984	3980	4027	3984	3905	3933
	in	<b>153.0</b>	<b>154.1</b>	<b>156.9</b>	<b>156.7</b>	<b>158.5</b>	<b>156.9</b>	<b>153.7</b>	<b>154.8</b>
Front clearance circle radius (with bucket)	mm	2654	2685	2718	2682	2713	2746	2655	2687
	in	<b>104.5</b>	<b>105.7</b>	<b>107.0</b>	<b>105.6</b>	<b>106.8</b>	<b>108.1</b>	<b>104.5</b>	<b>105.8</b>
Tipping load	kg	3698	3620	3674	3596	3519	3572	3524	3448
	lb	<b>8153</b>	<b>7981</b>	<b>8100</b>	<b>7928</b>	<b>7758</b>	<b>7875</b>	<b>7769</b>	<b>7602</b>
Breakout force — lift	kg	2273	2214	2255	2179	2118	2161	2146	2088
	lb	<b>5011</b>	<b>4881</b>	<b>4971</b>	<b>4804</b>	<b>4669</b>	<b>4764</b>	<b>4731</b>	<b>4603</b>
Breakout force — tilt	kg	3086	2923	3067	2743	2602	2724	2988	2830
	lb	<b>6803</b>	<b>6444</b>	<b>6762</b>	<b>6047</b>	<b>5736</b>	<b>6005</b>	<b>6587</b>	<b>6239</b>
Operating weight	kg	4552	4589	4570	4694	4736	4712	4699	4736
	lb	<b>10,035</b>	<b>10,117</b>	<b>10,075</b>	<b>10,348</b>	<b>10,441</b>	<b>10,388</b>	<b>10,359</b>	<b>10,441</b>

Bucket Type	Multi-Purpose				Dirt		
	1981 mm (78")	2134 mm (84")			1981 mm (78")		
Bucket Width							
Ground Engaging Type	Bolt-on Teeth	Holes Only	Bolt-on Edge	Bolt-on Teeth	Holes Only	Bolt-on Edge	
Bucket Assembly No.	279-5401	293-0139	296-8057	296-8055	268-4084	268-4083	
Rated bucket capacity	m <sup>3</sup> yd <sup>3</sup>	0.40 0.52	0.43 0.56	0.43 0.56	0.43 0.56	0.44 0.58	0.45 0.59
Struck capacity	m <sup>3</sup> yd <sup>3</sup>	0.28 0.37	0.30 0.39	0.30 0.39	0.30 0.39	0.32 0.42	0.32 0.42
Width	mm in	2035 80.1	2187 86.1	2198 86.5	2187 86.1	1981 78.0	1991 78.4
Dump clearance at maximum lift/dump	mm in	2536 99.8	2436 95.9	2405 94.7	2359 92.9	2579 101.5	2549 100.4
Reach at maximum lift/dump	mm in	974 38.3	816 32.1	821 32.3	876 34.5	931 36.7	942 37.1
Floor angle at maximum lift/dump	degrees	40°	51°	51°	51°	40°	40°
Floor angle at maximum lift/rack back	degrees	85°	83°	83°	83°	85°	85°
Clearance at maximum lift/level bucket	mm in	3043 119.8	3083 121.4	3067 120.7	3081 121.3	3043 119.8	3043 119.8
Hinge pin height at maximum lift	mm in	3233 127.3	3280 129.1	3280 129.1	3280 129.1	3233 127.3	3233 127.3
Maximum overall height	mm in	4124 162.4	4175 164.4	4201 165.4	4271 168.1	4075 160.4	4089 161.0
Reach at level lift arm/bucket	mm in	1399 55.1	1348 53.1	1376 54.2	1446 56.9	1301 51.2	1330 52.4
Maximum floor angle at minimum lift	degrees	26.4°	26.4°	26.4°	26.4°	26.4°	26.4°
Dig depth with level bucket	mm in	16 0.6	16 0.6	33 1.3	16 0.6	11 0.4	27 1.1
Overall length with bucket on ground	mm in	4002 157.6	3893 153.3	3921 154.4	3991 157.1	3852 151.7	3880 152.8
Front clearance circle radius (with bucket)	mm in	2720 107.1	2683 105.6	2715 106.9	2748 108.2	2612 102.8	2643 104.1
Tipping load	kg lb	3500 7716	3520 7760	3438 7579	3496 7707	3828 8439	3733 8230
Breakout force — lift	kg lb	2128 4691	2126 4687	2064 4550	2108 4647	2328 5132	2266 4996
Breakout force — tilt	kg lb	2969 6545	2979 6568	2817 6210	2959 6523	3314 7306	3129 6898
Operating weight	kg lb	4717 10,399	4828 10,644	4870 10,736	4846 10,684	4530 9987	4570 10,075

Work Tool	Pallet Fork			
		910 mm (36")	1070 mm (42")	1220 mm (48")
<b>Tine Length</b>				
<b>Carriage Assembly No.</b>		<b>293-9427</b>	<b>293-9428</b>	<b>293-9429</b>
Carriage overall width without step	<b>mm</b> <b>in</b>	1159 <b>45.6</b>	1159 <b>45.6</b>	1159 <b>45.6</b>
Carriage step additional width	<b>mm</b> <b>in</b>	106 <b>4.2</b>	106 <b>4.2</b>	106 <b>4.2</b>
Carriage height above blade top	<b>mm</b> <b>in</b>	930 <b>36.6</b>	930 <b>36.6</b>	930 <b>36.6</b>
Blade surface height at maximum height	<b>mm</b> <b>in</b>	3177 <b>125.1</b>	3177 <b>125.1</b>	3177 <b>125.1</b>
Shank front face reach at maximum height	<b>mm</b> <b>in</b>	703 <b>27.7</b>	703 <b>27.7</b>	703 <b>27.7</b>
Blade surface height at level lift arms	<b>mm</b> <b>in</b>	1608 <b>63.3</b>	1608 <b>63.3</b>	1608 <b>63.3</b>
Shank front face reach at level lift arms	<b>mm</b> <b>in</b>	751 <b>29.6</b>	751 <b>29.6</b>	751 <b>29.6</b>
Blade surface height at minimum lift	<b>mm</b> <b>in</b>	148 <b>5.8</b>	148 <b>5.8</b>	148 <b>5.8</b>
Shank front face reach at minimum lift	<b>mm</b> <b>in</b>	425 <b>16.7</b>	425 <b>16.7</b>	425 <b>16.7</b>
Overall length at minimum lift, level tine	<b>mm</b> <b>in</b>	4216 <b>166.0</b>	4376 <b>172.3</b>	4526 <b>178.2</b>
Tipping load	<b>kg</b> <b>lb</b>	3036 <b>6693</b>	2886 <b>6363</b>	2756 <b>6076</b>
Operating weight	<b>kg</b> <b>lb</b>	4488 <b>9894</b>	4498 <b>9916</b>	4508 <b>9938</b>

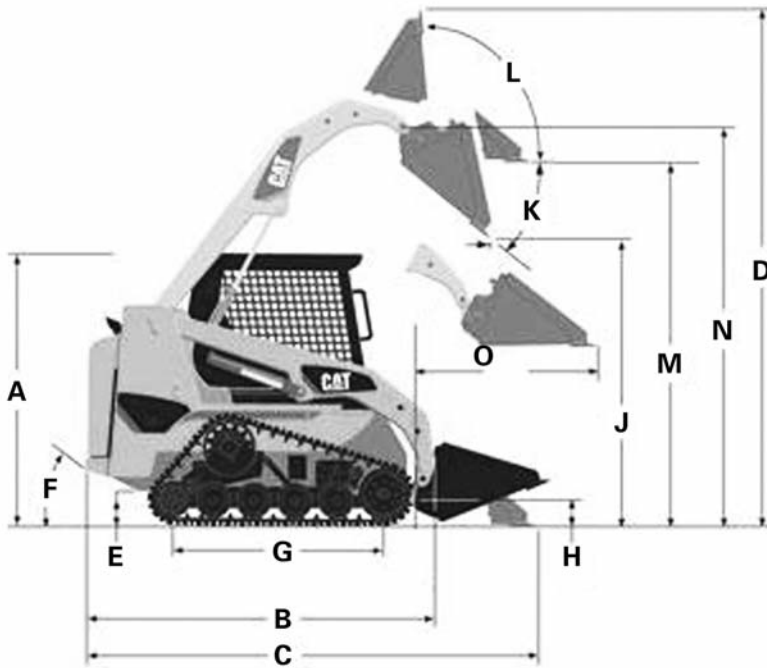

MODEL	247B2		257B2	
Rated operating capacity*	929 kg	<b>2050 lb</b>	1134 kg	<b>2500 lb</b>
A Height to top of ROPS	1990 mm	<b>6'6"</b>	2022 mm	<b>6'7"</b>
B Length to coupler	2518 mm	<b>8'3"</b>	2701 mm	<b>8'10"</b>
C Length with bucket on ground	3285 mm	<b>10'8"</b>	3490 mm	<b>11'5"</b>
D Maximum overall height	3799 mm	<b>12'4"</b>	3963 mm	<b>13'0"</b>
E Ground clearance	267 mm	<b>10.5"</b>	257 mm	<b>10"</b>
F Departure angle		<b>41°</b>		<b>37°</b>
G Wheelbase	1499 mm	<b>4'11"</b>	1499 mm	<b>4'11"</b>
H Hinge pin height at carry position	234 mm	<b>8"</b>	234 mm	<b>8"</b>
Bucket overall width with edge	1730 mm	<b>6'6"</b>	1730 mm	<b>6'6"</b>
J Clearance at maximum lift/dump	2134 mm	<b>7'0"</b>	2278 mm	<b>7'5"</b>
K Floor angle at maximum lift/dump		<b>40°</b>		<b>40°</b>
L Floor angle at maximum lift/rack		<b>96.7°</b>		<b>86.9°</b>
M Clearance at maximum lift/level	2667 mm	<b>8'8"</b>	2889 mm	<b>9'5"</b>
N Hinge pin height at maximum lift	2862 mm	<b>9'4"</b>	3018 mm	<b>10'1"</b>
O Reach at level lift arm/bucket	1395 mm	<b>4'7"</b>	1387 mm	<b>4'6"</b>
Bumper overhang from axle	576 mm	<b>1'10"</b>	672 mm	<b>2'2"</b>
Maximum floor angle at carry position		<b>26.4°</b>		<b>26.8°</b>

\*SAE J818 MAY87, ISO 5998:1986.

NOTE: 247B2/257B2 machine dimensions shown with standard machine equipped with 1676 mm (66") dirt bucket.

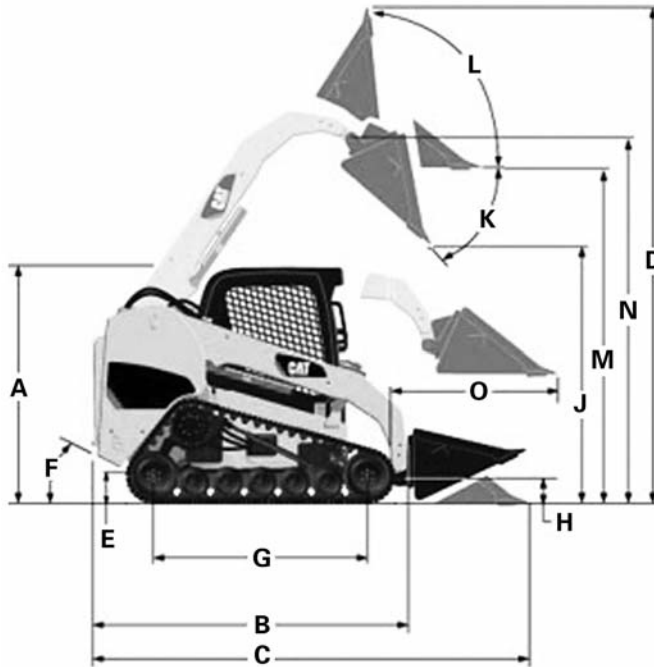

MODEL	277C		287C		297C	
Rated operating capacity*	1060 kg	<b>2337 lb</b>	1229 kg	<b>2709 lb</b>	1363 kg	<b>3005 lb</b>
Rated operating capacity at 50%	1451 kg	<b>3200 lb</b>	1724 kg	<b>3801 lb</b>	1905 kg	<b>4200 lb</b>
A Height to top of ROPS	2115 mm	<b>6'11"</b>	2115 mm	<b>6'11"</b>	2115 mm	<b>6'11"</b>
B Length to coupler	2974 mm	<b>9'9"</b>	2973 mm	<b>9'9"</b>	3115 mm	<b>10'3"</b>
C Length with bucket on ground	3692 mm	<b>12'1"</b>	3692 mm	<b>12'1"</b>	3833 mm	<b>12'7"</b>
D Maximum overall height	3998 mm	<b>13'1"</b>	4075 mm	<b>13'4"</b>	4115 mm	<b>13'6"</b>
E Ground clearance	225 mm	<b>8.9"</b>	225 mm	<b>8.9"</b>	225 mm	<b>8.9"</b>
F Departure angle		<b>42°</b>		<b>42°</b>		<b>35°</b>
G Wheelbase	1808 mm	<b>5'11"</b>	1808 mm	<b>5'11"</b>	1808 mm	<b>5'11"</b>
H Hinge pin height at carry position	200 mm	<b>7.9"</b>	200 mm	<b>7.9"</b>	200 mm	<b>7.9"</b>
Bucket overall width with edge	1981 mm	<b>6'6"</b>	1981 mm	<b>6'6"</b>	1981 mm	<b>6'6"</b>
J Clearance at maximum lift/dump	2425 mm	<b>7'11"</b>	2450 mm	<b>8'0"</b>	2487 mm	<b>8'0"</b>
K Floor angle at maximum lift/dump		<b>40°</b>		<b>50°</b>		<b>51°</b>
L Floor angle at maximum lift/rack		<b>85°</b>		<b>85°</b>		<b>83°</b>
M Clearance at maximum lift/level	2930 mm	<b>9'7"</b>	3043 mm	<b>10'0"</b>	3088 mm	<b>10'2"</b>
N Hinge pin height at maximum lift	3122 mm	<b>10'3"</b>	3233 mm	<b>10'7"</b>	3279 mm	<b>10'9"</b>
O Reach at level lift arm/bucket	1390 mm	<b>4'7"</b>	1285 mm	<b>4'3"</b>	1273 mm	<b>4'2"</b>
Bumper overhang from axle	689 mm	<b>2'3"</b>	689 mm	<b>2'3"</b>	830 mm	<b>2'9"</b>
Maximum floor angle at carry position		<b>26°</b>		<b>26°</b>		<b>26°</b>

\*SAE J818 MAY87, ISO 5998:1986.

NOTE: 277C/287C/297C machine dimensions shown with standard machine equipped with 1981 mm (78") dirt bucket.

**CAT WORK TOOL COMPATIBILITY**

	247B2	257B2	277C	287C	297C
<b>General Purpose Buckets</b>					
1524 mm (60")	A	A	NR	NR	NR
1676 mm (66")	O	O	NR	NR	NR
1829 mm (72")	O	O	A	A	A
1981 mm (78")	A	A	O	O	O
<b>High Capacity Bucket (GP)</b>					
2134 mm (84")	NR	NR	O	O	O
<b>Dirt Buckets</b>					
1524 mm (60")	A	A	NR	NR	NR
1676 mm (66")	O	O	NR	NR	NR
1829 mm (72")	O	O	A	A	A
1981 mm (78")	O	O	O	O	O
<b>Utility Buckets</b>					
1524 mm (60")	A	A	NR	NR	NR
1676 mm (66")	O	O	NR	NR	NR
1829 mm (72")	O	O	A	A	A
<b>Light Material Buckets</b>					
1829 mm (72")	O	O	A	A	A
1981 mm (78")	A	A	O	O	O
2134 mm (84")	A	A	O	O	O
2438 mm (96")	A	O	O	O	O
<b>Multi-Purpose Buckets</b>					
1524 mm (60")	A	A	NR	NR	NR
1676 mm (66")	O	O	NR	NR	NR
1829 mm (72")	O	O	A	A	A
1981 mm (78")	A	A	O	O	O
2134 mm (84")	NR	NR	O	O	O
<b>Industrial Grapple Buckets</b>					
1524 mm (60")	A	A	NR	NR	NR
1676 mm (66")	O	O	NR	NR	NR
1829 mm (72")	O	O	A	A	A
1981 mm (78")	A	A	O	O	O
<b>Industrial Grapple Forks</b>					
1676 mm (66")	O	O	A	A	A
1829 mm (72")	O	O	O	O	O
<b>Industrial Grapple Rakes</b>					
1829 mm (72")	O	O	O	O	O
2134 mm (84")	O	O	O	O	O
<b>Utility Grapple Buckets</b>					
1524 mm (60")	A	A	NR	NR	NR
1676 mm (66")	O	O	NR	NR	NR
1829 mm (72")	O	O	A	A	A

O – Provides Optimum Performance.  
 A – Provides Acceptable Performance.  
 NR – Not Recommended.

## CAT WORK TOOL COMPATIBILITY

	247B2	257B2	277C	287C	297C
<b>Carriage</b>	O	O	O	O	O
<b>Pallet Forks</b>					
910 mm (36") Tines	O	O	O	O	O
1070 mm (42") Tines	O	O	O	O	O
1220 mm (48") Tines	O	O	O	O	O
<b>Utility Grapple Forks</b>					
1676 mm (66")	O	O	A	A	A
1829 mm (72")	O	O	O	O	O
<b>Utility Forks</b>					
1676 mm (66")	O	O	A	A	A
1829 mm (72")	O	O	O	O	O
<b>Angle Blades</b>					
1829 mm (72")	A	A	NR	NR	NR
2134 mm (84")	O	O	O	O	O
<b>6 Way Blades</b>					
2000 mm (79")	O	O	O	O	O
2337 mm (92")	A	A	O	O	O
<b>A14B Auger</b>	O	O	O	O	O
<b>A19B Auger</b>	O	O	O	O	O
<b>A26B Auger</b>	X	X	O#	O#	O#
<b>Backhoe</b>					
BH150	O	O	X	X	X
BH160	X	X	O	O	O
BH27	O	O	X	X	X
BH30	O	O	X	X	X
BH30W	X	X	O	O	O
<b>BR160 Brushcutter</b>	O	O	O	O	O
<b>BR166 Brushcutter</b>	O	O	O	O	O
<b>BR172 Brushcutter</b>	O	O	O	O	O
<b>BR272 Brushcutter</b>	X	O#	X	X	X
<b>BR378 Brushcutter</b>	X	X	O#	O#	O#
<b>BP15B Pickup Broom</b>	O!	O	A	A	A
<b>BP18B Pickup Broom</b>	X	O!	O	O	O
<b>BA18 Angle Broom</b>	O	O	O	O	O
<b>BU115 Utility Broom</b>	O!	O	A	A	A
<b>BU118 Utility Broom</b>	X	O!	O	O	O

O – Provides Optimum Performance.

O# – The machine performance is optimum with the available HF/XPS option.

A – Provides Acceptable Performance.

NR – Not Recommended.

X – Not Approved. Do Not Use.

! – Lift Restriction.

**CAT WORK TOOL COMPATIBILITY**

	247B2	257B2	277C	287C	297C
PC203 Cold Planer	O	O	O	O	O
PC204 Cold Planer	X	A	O	O	O
PC205 Cold Planer	X	X	O#	O#	O#
PC206 Cold Planer	X	X	O#	O#	O#
PC210 Cold Planer	X	X	O#	O#	O#
H55D S Hammer	O	O	O	O	O
H65D S Hammer	O	O	O	O	O
LR15B Landscape Rake	O!	O!	NR	NR	NR
LR18B Landscape Rake	O!	O!	O	O	O
LT13B Landscape Tiller	O!	O!	NR	NR	NR
LT18B Landscape Tiller	O	O!	O	O	O
Material Handling Arm	O	O	O	O	O
HM312 Mulcher	X	X	O#	O#	O#
HM315 Mulcher	X	X	O#	O#	O#
PR172 Power Box Rake	O	O	A	A	A
PR184 Power Box Rake	O	O	O	O	O
PR190 Power Box Rake	A	A	O	O	O
SR117 Snowblower	O	O	NR	NR	NR
SR118 Snowblower	NR	NR	A	A	A
SR121 Snowblower	NR	NR	O	O	O
SR318 Snowblower	NR	O#	A#	A#	A#
SR321 Snowblower	NR	O#	O#	O#	O#
SG16B Stump Grinder	O	O	O	O	O
SG18B Stump Grinder	X	X	O#	O#	O#
T6B Trencher	O	O	O	O	O
T9B Trencher	A	O	O	O	O
T15 Trencher	X	X	O#	O#	O#
CV16B Vibratory Compactor	O!	O!	O	O	O
CV18B Vibratory Compactor	X	X	O	O	O
SW45 Wheel Saw	X	X	O#	O#	O#
SW60 Wheel Saw	X	X	O#	O#	O#

O – Provides Optimum Performance.  
 O# – The machine performance is optimum with the available HF/XPS option.  
 A – Provides Acceptable Performance.  
 A# – The machine performance is acceptable with the available HF/XPS option.  
 NR – Not Recommended.  
 X – Not Approved. Do Not Use.  
 ! – Lift Restriction.



# Compact Track Loaders

## Specifications ● 279C/289C/299C



MODEL	279C		289C		299C	
Flywheel Power: Net	61 kW	<b>82 hp</b>	61 kW	<b>82 hp</b>	67 kW	<b>90 hp</b>
Gross	63 kW	<b>84 hp</b>	63 kW	<b>85 hp</b>	70 kW	<b>94 hp</b>
Engine Model	<b>C3.4 DIT</b>		<b>C3.4 DIT</b>		<b>C3.4 DIT</b>	
Rated Engine RPM	<b>2500</b>		<b>2500</b>		<b>2500</b>	
Bore	94 mm	<b>3.7"</b>	94 mm	<b>3.7"</b>	94 mm	<b>3.7"</b>
Stroke	120 mm	<b>4.7"</b>	120 mm	<b>4.7"</b>	120 mm	<b>4.7"</b>
Displacement	3.3 L	<b>201 in<sup>3</sup></b>	3.3 L	<b>201 in<sup>3</sup></b>	3.3 L	<b>201 in<sup>3</sup></b>
No. Cylinders	<b>4</b>		<b>4</b>		<b>4</b>	
One Speed Forward	0-8.1 km/h	<b>0-5 mph</b>	0-8.1 km/h	<b>0-5 mph</b>	0-8.1 km/h	<b>0-5 mph</b>
Two Speed Forward	0-13.6 km/h	<b>0-8.5 mph</b>	0-13.6 km/h	<b>0-8.5 mph</b>	0-13.6 km/h	<b>0-8.5 mph</b>
One Speed Reverse	0-8.1 km/h	<b>0-5 mph</b>	0-8.1 km/h	<b>0-5 mph</b>	0-8.1 km/h	<b>0-5 mph</b>
Two Speed Reverse	0-13.6 km/h	<b>0-8.5 mph</b>	0-13.6 km/h	<b>0-8.5 mph</b>	0-13.6 km/h	<b>0-8.5 mph</b>
Hydraulic Cycle Time, Empty Bucket:	<b>Seconds</b>		<b>Seconds</b>		<b>Seconds</b>	
Raise	<b>3.1</b>		<b>4.7</b>		<b>4.7</b>	
Dump	<b>2.5</b>		<b>2.5</b>		<b>2.5</b>	
Lower (Empty, Float Down)	<b>4.0</b>		<b>4.6</b>		<b>4.6</b>	
Total	<b>9.6</b>		<b>11.8</b>		<b>11.8</b>	
Tread Width (per side)	457 mm	<b>18"</b>	457 mm	<b>18"</b>	457 mm	<b>18"</b>
Width Over Tracks	1981 mm	<b>78"</b>	1981 mm	<b>78"</b>	1981 mm	<b>78"</b>
Ground Clearance	231 mm	<b>9.1"</b>	231 mm	<b>9.1"</b>	231 mm	<b>9.1"</b>
Fuel Tank Capacity	98 L	<b>26 U.S. gal</b>	98 L	<b>26 U.S. gal</b>	98 L	<b>26 U.S. gal</b>
Hydraulic Tank Capacity	42 L	<b>11 U.S. gal</b>	42 L	<b>11 U.S. gal</b>	42 L	<b>11 U.S. gal</b>
Hydraulic System Capacity (includes tank)	57 L	<b>15.1 U.S. gal</b>	57 L	<b>15 U.S. gal</b>	57 L	<b>15 U.S. gal</b>
Hydraulic Pump Capacity	84 L/min	<b>22 gpm</b>	84 L/min	<b>22 gpm</b>	84 L/min	<b>22 gpm</b>

Bucket Type		General Purpose			High Capacity — GP			Multi-Purpose	
Bucket Width		1981 mm (78")			2134 mm (84")			1981 mm (78")	
Ground Engaging Type		Holes Only	Bolt-on Edge	Bolt-on Teeth	Holes Only	Bolt-on Edge	Bolt-on Teeth	Holes Only	Bolt-on Edge
Bucket Assembly No.		279-5376	279-5377	279-5378	292-9271	296-8192	296-8191	279-5403	279-5402
Rated bucket capacity	m <sup>3</sup>	0.47	0.49	0.47	0.63	0.63	0.63	0.40	0.42
	yd <sup>3</sup>	<b>0.61</b>	<b>0.64</b>	<b>0.61</b>	<b>0.82</b>	<b>0.82</b>	<b>0.82</b>	<b>0.52</b>	<b>0.55</b>
Struck capacity	m <sup>3</sup>	0.34	0.34	0.34	0.59	0.59	0.59	0.28	0.28
	yd <sup>3</sup>	<b>0.44</b>	<b>0.44</b>	<b>0.44</b>	<b>0.77</b>	<b>0.77</b>	<b>0.77</b>	<b>0.37</b>	<b>0.37</b>
Width	mm	2035	2045	2035	2187	2198	2187	2035	2045
	in	<b>80.1</b>	<b>80.5</b>	<b>80.1</b>	<b>86.1</b>	<b>86.5</b>	<b>86.1</b>	<b>80.1</b>	<b>80.5</b>
Dump clearance at maximum lift/dump	mm	2391	2361	2333	2330	2305	2277	2384	2354
	in	<b>94.0</b>	<b>93.0</b>	<b>91.9</b>	<b>92.0</b>	<b>90.7</b>	<b>89.6</b>	<b>94.0</b>	<b>92.7</b>
Reach at maximum lift/dump	mm	633	644	702	703	721	779	636	647
	in	<b>25.0</b>	<b>25.4</b>	<b>27.6</b>	<b>28.0</b>	<b>28.4</b>	<b>30.7</b>	<b>25.0</b>	<b>25.5</b>
Floor angle at maximum lift/dump	degrees	40°	40°	40°	*	*	*	40°	40°
Floor angle at maximum lift/rack back	degrees	85°	85°	85°	*	*	*	85°	85°
Clearance at maximum lift/level bucket	mm	2934	2918	2934	*	2918	2934	2931	2915
	in	<b>115.5</b>	<b>114.9</b>	<b>115.5</b>	*	<b>114.9</b>	<b>115.5</b>	<b>115.4</b>	<b>114.8</b>
Hinge pin height at maximum lift	mm	3128	3128	3128	3128	3128	3128	3128	3128
	in	<b>123.2</b>	<b>123.2</b>	<b>123.2</b>	<b>123.2</b>	<b>123.2</b>	<b>123.2</b>	<b>123.2</b>	<b>123.2</b>
Maximum overall height	mm	4058	4087	4148	*	4180	4241	4065	4094
	in	<b>159.8</b>	<b>160.9</b>	<b>163.3</b>	*	<b>164.6</b>	<b>167.0</b>	<b>160.0</b>	<b>161.2</b>
Reach at level lift arm/bucket	mm	1434	1466	1524	*	1555	1613	1447	1477
	in	<b>56.5</b>	<b>57.7</b>	<b>60.0</b>	*	<b>61.2</b>	<b>63.5</b>	<b>57.0</b>	<b>58.1</b>
Maximum floor angle at minimum lift	degrees	26°	26°	26°	26°	26°	26°	26°	26°
Dig depth with level bucket	mm	11	27	11	*	27	11	16	33
	in	<b>0.4</b>	<b>1.1</b>	<b>0.4</b>	*	<b>1.1</b>	<b>0.4</b>	<b>0.6</b>	<b>1.3</b>
Overall length with bucket on ground	mm	3726	3758	3816	*	3847	3905	3729	3759
	in	<b>146.7</b>	<b>148.0</b>	<b>150.2</b>	*	<b>151.5</b>	<b>153.7</b>	<b>146.8</b>	<b>148.0</b>
Front clearance circle radius (with bucket)	mm	2357	2389	2421	*	2474	2506	2360	2392
	in	<b>92.8</b>	<b>94.1</b>	<b>95.3</b>	*	<b>97.5</b>	<b>98.7</b>	<b>92.9</b>	<b>94.2</b>
Tipping load	kg	2838	2769	2815	2749	2675	2725	2679	2611
	lb	<b>6258</b>	<b>6106</b>	<b>6207</b>	<b>6062</b>	<b>5898</b>	<b>6009</b>	<b>5907</b>	<b>5757</b>
Breakout force — lift	kg	2631	2565	2614	*	2454	2504	2505	2440
	lb	<b>5801</b>	<b>5656</b>	<b>5764</b>	*	<b>5411</b>	<b>5521</b>	<b>5524</b>	<b>5380</b>
Breakout force — tilt	kg	3085	2923	3066	*	2602	2724	2988	2830
	lb	<b>6802</b>	<b>6445</b>	<b>6761</b>	*	<b>5737</b>	<b>6006</b>	<b>6589</b>	<b>6240</b>
Operating weight	kg	4509	4546	4527	*	4583	4559	4655	4692
	lb	<b>9942</b>	<b>10,024</b>	<b>9982</b>	*	<b>10,106</b>	<b>10,053</b>	<b>10,264</b>	<b>10,346</b>

\*Information not available at time of printing.

Bucket Type	Multi-Purpose				Dirt	
Bucket Width	1981 mm (78")	2134 mm (84")		1981 mm (78")		
Ground Engaging Type	Bolt-on Teeth	Holes Only	Bolt-on Edge	Bolt-on Teeth	Holes Only	Bolt-on Edge
Bucket Assembly No.	279-5401	293-0139	296-8057	296-8055	268-4084	268-4083
Rated bucket capacity	m <sup>3</sup> yd <sup>3</sup> 0.40 0.52	0.43 0.56	0.43 0.56	0.43 0.56	0.44 0.58	0.45 0.59
Struck capacity	m <sup>3</sup> yd <sup>3</sup> 0.28 0.37	0.30 0.39	0.30 0.39	0.30 0.39	0.32 0.42	0.32 0.42
Width	mm in 2035 80.1	2187 86.1	2198 86.5	2187 86.1	1981 78.0	1991 78.4
Dump clearance at maximum lift/dump	mm in 2326 91.6	2384 94.0	2354 92.7	2326 91.6	2427 95.6	2397 94.0
Reach at maximum lift/dump	mm in 705 27.8	636 25.0	647 25.5	705 27.8	594 23.4	605 24.0
Floor angle at maximum lift/dump	degrees 40°	*	*	*	40°	40°
Floor angle at maximum lift/rack back	degrees 85°	*	*	*	85°	85°
Clearance at maximum lift/level bucket	mm in 2931 115.4	2931 115.4	2915 114.8	2931 115.4	2937 115.6	2921 115.0
Hinge pin height at maximum lift	mm in 3128 123.2	3128 123.2	3128 123.2	3128 123.2	3128 123.2	3128 123.2
Maximum overall height	mm in 4155 163.6	4065 160.0	4094 161.2	4155 163.6	4005 157.7	4034 158.8
Reach at level lift arm/bucket	mm in 1537 60.5	1447 57.0	1447 57.0	1537 60.5	1387 54.6	1419 55.9
Maximum floor angle at minimum lift	degrees 26°	26°	26°	26°	26°	26°
Dig depth with level bucket	mm in 16 0.6	16 0.6	33 1.3	16 0.6	11 0.4	27 1.1
Overall length with bucket on ground	mm in 3819 150.4	3729 146.8	3759 148	3819 150.4	3679 144.8	3711 146.1
Front clearance circle radius (with bucket)	mm in 2424 95.4	2474 97.4	2506 98.7	2538 99.9	2314 91.1	2345 92.3
Tipping load	kg lb 2656 5857	2661 5868	2588 5707	2638 5817	2941 6485	2859 6304
Breakout force — lift	kg lb 2487 5484	2490 5491	2421 5338	2472 5451	2699 5951	2628 5795
Breakout force — tilt	kg lb 2969 6547	2979 6569	2817 6212	2959 6525	3314 7307	3129 6884
Operating weight	kg lb 4673 10,304	4674 10,306	4716 10,399	4692 10,346	4487 9894	4527 9982

\*Information not available at time of printing.

Work Tool	Pallet Fork			
		910 mm (36")	1070 mm (42")	1220 mm (48")
<b>Tine Length</b>				
<b>Carriage Assembly No.</b>		<b>261-6681</b>	<b>261-6681</b>	<b>261-6681</b>
Carriage overall width without step	mm in	1159 <b>45.6</b>	1159 <b>45.6</b>	1159 <b>45.6</b>
Carriage step additional width	mm in	106 <b>4.2</b>	106 <b>4.2</b>	106 <b>4.2</b>
Carriage height above blade top	mm in	930 <b>36.6</b>	930 <b>36.6</b>	930 <b>36.6</b>
Blade surface height at maximum height	mm in	3025 <b>119.0</b>	3025 <b>119.0</b>	3025 <b>119.0</b>
Shank front face reach at maximum height	mm in	381 <b>15.0</b>	381 <b>15.0</b>	381 <b>15.0</b>
Blade surface height at level lift arms	mm in	1545 <b>60.8</b>	1545 <b>60.8</b>	1545 <b>60.8</b>
Shank front face reach at level lift arms	mm in	849 <b>33.0</b>	849 <b>33.0</b>	849 <b>33.0</b>
Blade surface height at minimum lift	mm in	122 <b>4.8</b>	122 <b>4.8</b>	122 <b>4.8</b>
Shank front face reach at minimum lift	mm in	409 <b>16.1</b>	409 <b>16.1</b>	409 <b>16.1</b>
Overall length at minimum lift, level tine	mm in	3997 <b>157.4</b>	4149 <b>163.3</b>	4302 <b>169.4</b>
Tippling load	kg lb	2465 <b>5435</b>	2316 <b>5107</b>	2193 <b>4836</b>
Operating weight	kg lb	4449 <b>9810</b>	4459 <b>9832</b>	4468 <b>9852</b>

Bucket Type	General Purpose			High Capacity — GP			Multi-Purpose		
Bucket Width	1981 mm (78")			2134 mm (84")			1981 mm (78")		
Ground Engaging Type	Holes Only	Bolt-on Edge	Bolt-on Teeth	Holes Only	Bolt-on Edge	Bolt-on Teeth	Holes Only	Bolt-on Edge	
Bucket Assembly No.	279-5376	279-5377	279-5378	292-9270	296-8192	296-8191	279-5403	279-5402	
Rated bucket capacity	m <sup>3</sup> yd <sup>3</sup>	0.47 0.61	0.49 0.64	0.47 0.61	0.63 0.82	0.63 0.82	0.63 0.82	0.40 0.52	0.42 0.55
Struck capacity	m <sup>3</sup> yd <sup>3</sup>	0.34 0.44	0.34 0.44	0.34 0.44	0.59 0.77	0.59 0.77	0.59 0.77	0.28 0.37	0.28 0.37
Width	mm in	2035 80.1	2045 80.5	2035 80.1	2187 86.1	2198 86.5	2187 86.1	2035 80.1	2045 80.5
Dump clearance at maximum lift/dump	mm in	2414 95.0	2382 93.8	2345 92.3	2341 92.0	2309 90.9	2272 89.4	2406 95.0	2374 93.5
Reach at maximum lift/dump	mm in	813 32.0	819 32.2	871 34.3	872 34.0	877 34.5	930 36.6	815 32.0	821 32.3
Floor angle at maximum lift/dump	degrees	50°	50°	50°	*	*	*	*	*
Floor angle at maximum lift/rack back	degrees	85°	85°	85°	*	*	*	*	*
Clearance at maximum lift/level bucket	mm in	3044 119.8	3028 119.2	3044 119.8	3044 119.8	3028 119.2	3044 119.8	3041 119.7	3025 119.1
Hinge pin height at maximum lift	mm in	3239 127.5	3239 127.5	3239 127.5	3239 127.5	3239 127.5	3239 127.5	3239 127.5	3239 127.5
Maximum overall height	mm in	4134 162.8	4160 163.8	4224 166.3	4227 166.4	4253 167.4	4317 170.0	4141 163.0	4167 164.1
Reach at level lift arm/bucket	mm in	1335 52.8	1363 53.7	1425 56.1	1424 56.1	1456 57.3	1514 59.6	1342 52.8	1370 53.9
Maximum floor angle at minimum lift	degrees	26°	26°	26°	26°	26°	26°	26°	26°
Dig depth with level bucket	mm in	11 0.4	27 1.1	11 0.4	11 0.4	27 1.1	11 0.4	16 0.6	33 1.3
Overall length with bucket on ground	mm in	3726 146.7	3758 148.0	3816 150.2	3815 150.2	3847 151.5	3905 153.7	3729 146.8	3759 148.0
Front clearance circle radius (with bucket)	mm in	2357 92.8	2389 94.1	2421 95.3	2442 96.1	2474 97.4	2506 98.7	2360 92.9	2392 94.2
Tipping load	kg lb	3378 7448	3303 7283	3355 7397	3274 7219	3195 7045	3250 7166	3213 7085	3139 6922
Breakout force — lift	kg lb	2410 5314	2348 5177	2392 5288	2313 5100	2249 4959	2295 5061	2283 5034	2223 4902
Breakout force — tilt	kg lb	3086 6805	2923 6445	3066 6761	2743 6048	2602 5737	2724 6006	2988 6589	2830 6240
Operating weight	kg lb	4724 10,416	4761 10,498	4742 10,456	4756 10,487	4798 10,580	4774 10,527	4870 10,738	4907 10,820

\*Information not available at time of printing.

Bucket Type	Multi-Purpose				Dirt	
Bucket Width	1981 mm (78")	2134 mm (84")		1981 mm (78")		
Ground Engaging Type	Bolt-on Teeth	Holes Only	Bolt-on Edge	Bolt-on Teeth	Holes Only	Bolt-on Edge
Bucket Assembly No.	279-5401	293-0139	296-8057	296-8055	268-4084	268-4083
Rated bucket capacity	m <sup>3</sup> yd <sup>3</sup> 0.40 0.52	0.43 0.56	0.43 0.56	0.43 0.56	0.44 0.58	0.45 0.59
Struck capacity	m <sup>3</sup> yd <sup>3</sup> 0.28 0.37	0.30 0.39	0.30 0.39	0.30 0.39	0.32 0.42	0.32 0.42
Width	mm in 2035 80.1	2187 86.1	2198 86.5	2187 86.1	1981 78.0	1991 78.4
Dump clearance at maximum lift/dump	mm in 2337 92.0	2406 95.0	2374 93.5	2337 92.0	2456 96.7	2424 95.0
Reach at maximum lift/dump	mm in 873 34.4	815 32.0	821 32.2	873 34.4	781 30.7	786 31.0
Floor angle at maximum lift/dump	degrees 50°	*	*	*	50°	50°
Floor angle at maximum lift/rack back	degrees 85°	*	*	*	85°	85°
Clearance at maximum lift/level bucket	mm in 3041 119.7	3041 119.7	3025 119.1	3041 119.7	3047 120.0	3031 119.3
Hinge pin height at maximum lift	mm in 3239 127.5	3239 127.5	3239 127.5	3239 127.5	3239 127.5	3239 127.5
Maximum overall height	mm in 4231 166.6	4141 163.0	4167 164.1	4231 166.6	4081 160.7	4108 161.7
Reach at level lift arm/bucket	mm in 1432 56.4	1342 52.8	1370 53.9	1432 56.4	1282 50.5	1309 51.5
Maximum floor angle at minimum lift	degrees 26°	26°	26°	26°	26°	26°
Dig depth with level bucket	mm in 16 0.6	16 0.6	33 1.3	16 0.6	11 0.4	27 1.1
Overall length with bucket on ground	mm in 3819 150.4	3729 146.8	3759 148.0	3819 150.4	3679 144.8	3711 146.1
Front clearance circle radius (with bucket)	mm in 2424 95.4	2474 97.4	2506 98.7	2538 99.9	2314 91.1	2345 92.3
Tipping load	kg lb 3190 7034	3196 7047	3116 6871	3172 6994	3502 7722	3412 7523
Breakout force — lift	kg lb 2265 4994	2267 4999	2203 4858	2249 4959	2469 5444	2404 5301
Breakout force — tilt	kg lb 2969 6547	2979 6569	2817 6212	2959 6525	3314 7307	3129 6899
Operating weight	kg lb 4888 10,778	4889 10,780	4931 10,873	4907 10,820	4702 10,368	4742 10,456

\*Information not available at time of printing.

<b>Work Tool</b>		<b>Pallet Fork</b>		
		<b>910 mm (36")</b>	<b>1070 mm (42")</b>	<b>1220 mm (48")</b>
<b>Tine Length</b>				
<b>Carriage Assembly No.</b>		<b>261-6681</b>	<b>261-6681</b>	<b>261-6681</b>
Carriage overall width without step	<b>mm</b>	1159	1159	1159
	<b>in</b>	<b>45.6</b>	<b>45.6</b>	<b>45.6</b>
Carriage step additional width	<b>mm</b>	106	106	106
	<b>in</b>	<b>4.2</b>	<b>4.2</b>	<b>4.2</b>
Carriage height above blade top	<b>mm</b>	930	930	930
	<b>in</b>	<b>36.6</b>	<b>36.6</b>	<b>36.6</b>
Blade surface height at maximum height	<b>mm</b>	3130	3130	3130
	<b>in</b>	<b>123.0</b>	<b>123.0</b>	<b>123.0</b>
Shank front face reach at maximum height	<b>mm</b>	695	695	695
	<b>in</b>	<b>27.4</b>	<b>27.4</b>	<b>27.4</b>
Blade surface height at level lift arms	<b>mm</b>	1636	1636	1636
	<b>in</b>	<b>64.4</b>	<b>64.4</b>	<b>64.4</b>
Shank front face reach at level lift arms	<b>mm</b>	743	743	743
	<b>in</b>	<b>29.0</b>	<b>29.0</b>	<b>29.0</b>
Blade surface height at minimum lift	<b>mm</b>	122	122	122
	<b>in</b>	<b>4.8</b>	<b>4.8</b>	<b>4.8</b>
Shank front face reach at minimum lift	<b>mm</b>	409	409	409
	<b>in</b>	<b>16.1</b>	<b>16.1</b>	<b>16.1</b>
Overall length at minimum lift, level tine	<b>mm</b>	3997	4149	4302
	<b>in</b>	<b>157.4</b>	<b>163.3</b>	<b>169.4</b>
Tipping load	<b>kg</b>	2891	2709	2560
	<b>lb</b>	<b>6375</b>	<b>5973</b>	<b>5645</b>
Operating weight	<b>kg</b>	4664	4674	4683
	<b>lb</b>	<b>10,284</b>	<b>10,306</b>	<b>10,326</b>

Bucket Type		General Purpose			High Capacity — GP			Multi-Purpose	
Bucket Width		1981 mm (78")			2134 mm (84")			1981 mm (78")	
Ground Engaging Type		Holes Only	Bolt-on Edge	Bolt-on Teeth	Holes Only	Bolt-on Edge	Bolt-on Teeth	Holes Only	Bolt-on Edge
Bucket Assembly No.		279-5376	279-5377	279-5378	292-9270	296-8192	296-8191	279-5403	279-5402
Rated bucket capacity	m <sup>3</sup>	0.47	0.49	0.47	0.63	0.63	0.63	0.40	0.42
	yd <sup>3</sup>	<b>0.61</b>	<b>0.64</b>	<b>0.61</b>	<b>0.82</b>	<b>0.82</b>	<b>0.82</b>	<b>0.52</b>	<b>0.55</b>
Struck capacity	m <sup>3</sup>	0.34	0.34	0.34	0.59	0.59	0.59	0.28	0.28
	yd <sup>3</sup>	<b>0.44</b>	<b>0.44</b>	<b>0.44</b>	<b>0.77</b>	<b>0.77</b>	<b>0.77</b>	<b>0.37</b>	<b>0.37</b>
Width	mm	2035	2045	2035	2187	2198	2187	2035	2045
	in	<b>80.1</b>	<b>80.5</b>	<b>80.1</b>	<b>86.1</b>	<b>86.5</b>	<b>86.1</b>	<b>80.1</b>	<b>80.5</b>
Dump clearance at maximum lift/dump	mm	2450	2418	2380	2376	2344	2306	2442	2410
	in	<b>96.0</b>	<b>95.2</b>	<b>93.7</b>	<b>94.0</b>	<b>92.3</b>	<b>90.8</b>	<b>96.0</b>	<b>94.9</b>
Reach at maximum lift/dump	mm	794	799	851	851	856	908	796	801
	in	<b>31.0</b>	<b>31.5</b>	<b>33.5</b>	<b>34.0</b>	<b>33.7</b>	<b>35.7</b>	<b>31.0</b>	<b>31.5</b>
Floor angle at maximum lift/dump	degrees	51°	51°	51°	*	*	*	51°	51°
Floor angle at maximum lift/rack back	degrees	83°	83°	83°	*	*	*	83°	83°
Clearance at maximum lift/level bucket	mm	3092	3076	3092	3092	3076	3092	3089	3072
	in	<b>121.7</b>	<b>121.1</b>	<b>121.7</b>	<b>121.7</b>	<b>121.1</b>	<b>121.7</b>	<b>121.6</b>	<b>120.9</b>
Hinge pin height at maximum lift	mm	3286	3286	3286	3286	3286	3286	3286	3286
	in	<b>129.4</b>	<b>129.4</b>	<b>129.4</b>	<b>129.4</b>	<b>129.4</b>	<b>129.4</b>	<b>129.4</b>	<b>129.4</b>
Maximum overall height	mm	4174	4200	4263	4266	4292	4355	4180	4206
	in	<b>164.3</b>	<b>165.4</b>	<b>167.8</b>	<b>168.0</b>	<b>169.0</b>	<b>171.5</b>	<b>164.6</b>	<b>165.6</b>
Reach at level lift arm/bucket	mm	1322	1350	1412	1411	1443	1501	1329	1357
	in	<b>52.0</b>	<b>53.1</b>	<b>55.6</b>	<b>55.6</b>	<b>56.8</b>	<b>59.1</b>	<b>52.3</b>	<b>53.4</b>
Maximum floor angle at minimum lift	degrees	26°	26°	26°	26°	26°	26°	26°	26°
Dig depth with level bucket	mm	11	27	11	11	27	11	16	33
	in	<b>0.4</b>	<b>1.1</b>	<b>0.4</b>	<b>0.4</b>	<b>1.1</b>	<b>0.4</b>	<b>0.6</b>	<b>1.3</b>
Overall length with bucket on ground	mm	3956	3988	4046	3956	3988	4046	3870	3900
	in	<b>155.7</b>	<b>157.0</b>	<b>159.3</b>	<b>155.7</b>	<b>157.0</b>	<b>159.3</b>	<b>152.4</b>	<b>153.5</b>
Front clearance circle radius (with bucket)	mm	2442	2474	2506	2442	2474	2506	2360	2392
	in	<b>96.1</b>	<b>97.4</b>	<b>98.7</b>	<b>96.1</b>	<b>97.4</b>	<b>98.7</b>	<b>92.9</b>	<b>94.2</b>
Tipping load	kg	3653	3576	3629	3543	3463	3519	3485	3410
	lb	<b>8055</b>	<b>7885</b>	<b>8002</b>	<b>7812</b>	<b>7636</b>	<b>7759</b>	<b>7684</b>	<b>7519</b>
Breakout force — lift	kg	2276	2217	2258	2185	2124	2168	2149	2091
	lb	<b>5019</b>	<b>4889</b>	<b>4879</b>	<b>4818</b>	<b>4683</b>	<b>4780</b>	<b>4739</b>	<b>4611</b>
Breakout force — tilt	kg	3086	2923	3067	2743	2602	2724	2988	2830
	lb	<b>6805</b>	<b>6445</b>	<b>6763</b>	<b>6048</b>	<b>5737</b>	<b>6006</b>	<b>6589</b>	<b>6240</b>
Operating weight	kg	4889	4926	4907	4921	4963	4939	5036	5073
	lb	<b>10,780</b>	<b>10,862</b>	<b>10,820</b>	<b>10,851</b>	<b>10,943</b>	<b>10,891</b>	<b>11,104</b>	<b>11,186</b>

\*Information not available at time of printing.



Bucket Type	Multi-Purpose				Dirt		
Bucket Width	1981 mm (78")	2134 mm (84")		1981 mm (78")			
Ground Engaging Type	Bolt-on Teeth	Holes Only	Bolt-on Edge	Bolt-on Teeth	Holes Only	Bolt-on Edge	
Bucket Assembly No.	279-5401	293-0139	296-8057	296-8055	268-4084	268-4083	
Rated bucket capacity	m <sup>3</sup> yd <sup>3</sup>	0.40 0.52	0.43 0.56	0.43 0.56	0.43 0.56	0.44 0.58	0.45 0.59
Struck capacity	m <sup>3</sup> yd <sup>3</sup>	0.28 0.37	0.30 0.39	0.30 0.39	0.30 0.39	0.32 0.42	0.32 0.42
Width	mm in	2035 80.1	2187 86.1	2198 86.5	2187 86.1	1981 78.0	1991 78.4
Dump clearance at maximum lift/dump	mm in	2372 93.4	2442 96.0	2410 94.9	2372 93.4	2493 98.1	2461 97.0
Reach at maximum lift/dump	mm in	853 33.6	796 31.0	801 31.5	853 33.6	763 30.0	768 30.0
Floor angle at maximum lift/dump	degrees	51°	*	*	*	51°	51°
Floor angle at maximum lift/rack back	degrees	83°	*	*	*	83°	83°
Clearance at maximum lift/level bucket	mm in	3089 121.6	3089 121.6	3072 120.9	3089 121.6	3094 121.8	3078 121.2
Hinge pin height at maximum lift	mm in	3286 129.4	3286 129.4	3286 129.4	3286 129.4	3286 129.4	3286 129.4
Maximum overall height	mm in	4269 168.1	4180 164.6	4206 165.6	4269 168.1	4121 162.2	4147 163.3
Reach at level lift arm/bucket	mm in	1419 55.9	1329 52.3	1357 53.4	1419 55.9	1269 50.0	1297 51.1
Maximum floor angle at minimum lift	degrees	26°	26°	26°	26°	26°	26°
Dig depth with level bucket	mm in	16 0.6	16 0.6	33 1.3	16 0.6	11 0.4	27 1.1
Overall length with bucket on ground	mm in	3960 155.9	3870 152.4	3900 153.5	3960 155.9	3820 150.4	3852 151.7
Front clearance circle radius (with bucket)	mm in	2424 95.4	2474 97.4	2506 98.7	2538 99.9	2314 91.1	2345 92.3
Tipping load	kg lb	3462 7634	3468 7647	3387 7468	3444 7594	3782 8339	3690 8136
Breakout force — lift	kg lb	2131 4699	2133 4703	2071 4567	2115 4664	2331 5140	2269 5003
Breakout force — tilt	kg lb	2969 6547	2979 6569	2817 6212	2959 6525	3314 7307	3129 6899
Operating weight	kg lb	5054 11,144	5055 11,146	5097 11,239	5073 11,186	4867 10,732	4907 10,820

\*Information not available at time of printing.

Work Tool		Pallet Fork		
		910 mm (36")	1070 mm (42")	1220 mm (48")
<b>Tine Length</b>				
<b>Carriage Assembly No.</b>		<b>261-6681</b>	<b>261-6681</b>	<b>261-6681</b>
Carriage overall width without step	mm	1159	1159	1159
	in	<b>45.6</b>	<b>45.6</b>	<b>45.6</b>
Carriage step additional width	mm	106	106	106
	in	<b>4.2</b>	<b>4.2</b>	<b>4.2</b>
Carriage height above blade top	mm	930	930	930
	in	<b>36.6</b>	<b>36.6</b>	<b>36.6</b>
Blade surface height at maximum height	mm	3177	3177	3177
	in	<b>125.0</b>	<b>125.0</b>	<b>125.0</b>
Shank front face reach at maximum height	mm	698	698	698
	in	<b>27.5</b>	<b>27.5</b>	<b>27.5</b>
Blade surface height at level lift arms	mm	1677	1677	1677
	in	<b>66.0</b>	<b>66.0</b>	<b>66.0</b>
Shank front face reach at level lift arms	mm	730	730	730
	in	<b>29.0</b>	<b>29.0</b>	<b>29.0</b>
Blade surface height at minimum lift	mm	122	122	122
	in	<b>4.8</b>	<b>4.8</b>	<b>4.8</b>
Shank front face reach at minimum lift	mm	409	409	409
	in	<b>16.1</b>	<b>16.1</b>	<b>16.1</b>
Overall length at minimum lift, level tine	mm	4138	4290	4443
	in	<b>162.9</b>	<b>168.9</b>	<b>174.9</b>
Tipping load	kg	3124	2932	2774
	lb	<b>6888</b>	<b>6465</b>	<b>6117</b>
Operating weight	kg	4830	4840	4849
	lb	<b>10,635</b>	<b>10,672</b>	<b>10,692</b>

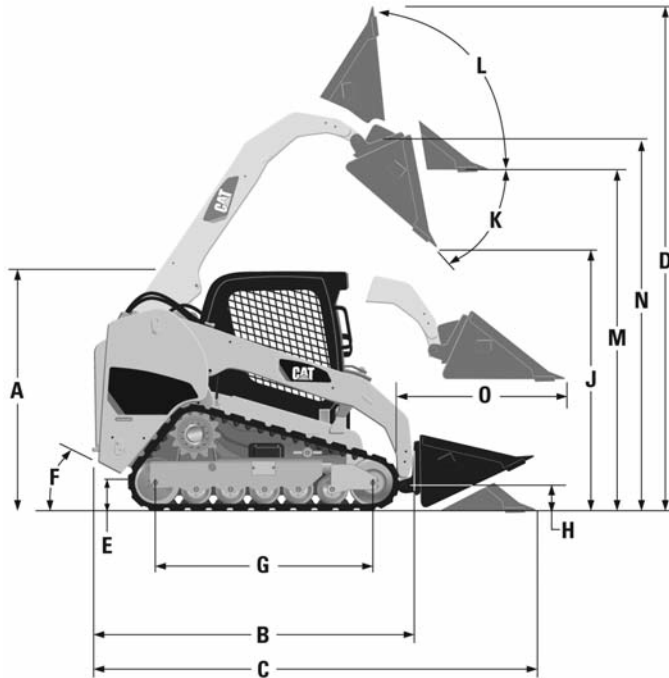

MODEL	279C		289C		299C	
Rated operating capacity	1016 kg	<b>2240 lb</b>	1222 kg	<b>2695 lb</b>	1318 kg	<b>2905 lb</b>
Rated operating capacity at 50%	1451 kg	<b>3200 lb</b>	1746 kg	<b>3850 lb</b>	1882 kg	<b>4150 lb</b>
A Height to top of ROPS	2117 mm	<b>6'11"</b>	2117 mm	<b>6'11"</b>	2117 mm	<b>6'11"</b>
B Length to coupler	2960 mm	<b>9'9"</b>	2960 mm	<b>9'8"</b>	3101 mm	<b>10'2"</b>
C Length with bucket on ground	3679 mm	<b>12'1"</b>	3679 mm	<b>12'1"</b>	3820 mm	<b>12'7"</b>
D Maximum overall height	4005 mm	<b>13'2"</b>	4081 mm	<b>13'5"</b>	4121 mm	<b>13'6"</b>
E Ground clearance	231 mm	<b>9.1"</b>	231 mm	<b>9.1"</b>	231 mm	<b>9.1"</b>
F Departure angle		<b>44°</b>		<b>44°</b>		<b>38°</b>
G Wheelbase	1767 mm	<b>5'10"</b>	1767 mm	<b>5'10"</b>	1767 mm	<b>5'10"</b>
H Hinge pin height at carry position	195 mm	<b>7.7"</b>	195 mm	<b>7.7"</b>	195 mm	<b>7.7"</b>
Bucket overall width with edge	1981 mm	<b>6'6"</b>	1981 mm	<b>6'6"</b>	1981 mm	<b>6'6"</b>
J Clearance at maximum lift/dump	2395 mm	<b>7'10"</b>	2456 mm	<b>8'1"</b>	2493 mm	<b>8'2"</b>
K Floor angle at maximum lift/dump		<b>40°</b>		<b>50°</b>		<b>51°</b>
L Floor angle at maximum lift/rack		<b>85°</b>		<b>85°</b>		<b>83°</b>
M Clearance at maximum lift/level	2937 mm	<b>9'8"</b>	3047 mm	<b>10'0"</b>	3094 mm	<b>10'2"</b>
N Hinge pin height at maximum lift	3128 mm	<b>10'3"</b>	3239 mm	<b>10'8"</b>	3286 mm	<b>10'9"</b>
O Reach at level lift arm/bucket	1387 mm	<b>4'7"</b>	1282 mm	<b>4'3"</b>	1269 mm	<b>4'2"</b>
Bumper overhang from axle	719 mm	<b>2'4"</b>	719 mm	<b>2'4"</b>	860 mm	<b>2'10"</b>
Maximum floor angle at carry position		<b>26°</b>		<b>26°</b>		<b>26°</b>

**CAT WORK TOOL COMPATIBILITY**

	279C	289C	299C
<b>General Purpose Buckets</b>			
1524 mm (60")	NR	NR	NR
1676 mm (66")	NR	NR	NR
1829 mm (72")	A	A	A
1981 mm (78")	O	O	O
<b>High Capacity Bucket (GP)</b>			
2134 mm (84")	O	O	O
<b>Dirt Buckets</b>			
1524 mm (60")	NR	NR	NR
1676 mm (66")	NR	NR	NR
1829 mm (72")	A	A	A
1981 mm (78")	O	O	O
<b>Utility Buckets</b>			
1524 mm (60")	NR	NR	NR
1676 mm (66")	NR	NR	NR
1829 mm (72")	A	A	A
<b>Light Material Buckets</b>			
1829 mm (72")	A	A	A
1981 mm (78")	O	O	O
2134 mm (84")	O	O	O
2438 mm (96")	O	O	O
<b>Multi-Purpose Buckets</b>			
1524 mm (60")	NR	NR	NR
1676 mm (66")	NR	NR	NR
1829 mm (72")	A	A	A
1981 mm (78")	O	O	O
2134 mm (84")	O	O	O
<b>Industrial Grapple Buckets</b>			
1524 mm (60")	NR	NR	NR
1676 mm (66")	NR	NR	NR
1829 mm (72")	A	A	A
1981 mm (78")	O	O	O
<b>Industrial Grapple Forks</b>			
1676 mm (66")	A	A	A
1829 mm (72")	O	O	O
<b>Industrial Grapple Rakes</b>			
1829 mm (72")	O	O	O
2134 mm (84")	O	O	O
<b>Utility Grapple Buckets</b>			
1524 mm (60")	NR	NR	NR
1676 mm (66")	NR	NR	NR
1829 mm (72")	A	A	A

O – Provides Optimum Performance.  
A – Provides Acceptable Performance.  
NR – Not Recommended.

**CAT WORK TOOL COMPATIBILITY**

	279C	289C	299C
<b>Carriage</b>	O	O	O
<b>Pallet Forks</b>			
910 mm (36") Tines	O	O	O
1070 mm (42") Tines	O	O	O
1220 mm (48") Tines	O	O	O
<b>Utility Grapple Forks</b>			
1676 mm (66")	A	A	A
1829 mm (72")	O	O	O
<b>Utility Forks</b>			
1676 mm (66")	A	A	A
1829 mm (72")	O	O	O
<b>Angle Blades</b>			
1829 mm (72")	NR	NR	NR
2134 mm (84")	O	O	O
<b>6 Way Blades</b>			
2000 mm (79")	O	O	O
2337 mm (92")	O	O	O
<b>A14B Auger</b>	O	O	O
<b>A19B Auger</b>	O	O	O
<b>A26B Auger</b>	O#	O#	O#
<b>Backhoe</b>			
BH150	X	X	X
BH160	O	O	O
BH27	X	X	X
BH30	X	X	X
BH30W	O	O	O
<b>BR160 Brushcutter</b>	O	O	O
<b>BR166 Brushcutter</b>	O	O	O
<b>BR172 Brushcutter</b>	O	O	O
<b>BR272 Brushcutter</b>	O#	O#	O#
<b>BR378 Brushcutter</b>	O#	O#	O#
<b>BP15B Pickup Broom</b>	A	A	A
<b>BP18B Pickup Broom</b>	O	O	O
<b>BA18 Angle Broom</b>	O	O	O
<b>BU115 Utility Broom</b>	A	A	A
<b>BU118 Utility Broom</b>	O	O	O

O – Provides Optimum Performance.

O# – The machine performance is optimum with the available HF/XPS option.

A – Provides Acceptable Performance.

NR – Not Recommended.

X – Not Approved. Do Not Use.

**CAT WORK TOOL COMPATIBILITY**

	279C	289C	299C
PC203 Cold Planer	O	O	O
PC204 Cold Planer	O	O	O
PC205 Cold Planer	O#	O#	O#
PC206 Cold Planer	O#	O#	O#
PC210 Cold Planer	O#	O#	O#
H55D S Hammer	O	O	O
H65D S Hammer	O	O	O
LR15B Landscape Rake	NR	NR	NR
LR18B Landscape Rake	O	O	O
LT13B Landscape Tiller	NR	NR	NR
LT18B Landscape Tiller	O	O	O
Material Handling Arm	O	O	O
HM312 Mulcher	O#	O#	O#
HM315 Mulcher	O#	O#	O#
PR172 Power Box Rake	A	A	A
PR184 Power Box Rake	O	O	O
PR190 Power Box Rake	O	O	O
SR117 Snowblower	NR	NR	NR
SR118 Snowblower	A	A	A
SR121 Snowblower	O	O	O
SR318 Snowblower	O#	O#	O#
SR321 Snowblower	O#	O#	O#
SG16B Stump Grinder	O	O	O
SG18B Stump Grinder	O#	O#	O#
T6B Trencher	O	O	O
T9B Trencher	O	O	O
T15 Trencher	O#	O#	O#
CV16B Vibratory Compactor	O	O	O
CV18B Vibratory Compactor	O	O	O
SW45 Wheel Saw	O#	O#	O#
SW60 Wheel Saw	O#	O#	O#

O – Provides Optimum Performance.

O# – The machine performance is optimum with the available HF/XPS option.

A – Provides Acceptable Performance.

NR – Not Recommended.

**Features:**

- **Cat XT™-3 hose and O-ring face seals** are used throughout for superior leak-free performance.
- **Both standard and tree bits are available in a variety of sizes** for a wide range of projects.
- **Standard bit teeth and pilot points** are produced from hardened steel. Optional hardfaced and carbide inserted teeth are also available.
- **Optional bit extension is available** in 305 mm (12") length.
- **Hex-to-round shaft adapter is available** to accommodate existing round auger bit mountings.
- **A14B and A19B** are compatible with both mini hydraulic excavators and skid steer loaders.

**A14B Auger**

- **Direct drive system** features a variable speed, bi-directional, “Gerotor” style hydraulic motor that generates optimal speed and output torque for light to moderate duty work.

**A19B Auger**

- **Single reduction planetary drive system** transfers power from the drive motor to the drive shaft, reducing motor speed and increasing torque.
- **Drive motor shaft** is splined and couples directly to the planetary gearbox.

**A26B Auger**

- **Double reduction planetary drive system** transfers power from the drive motor to the drive shaft, reducing motor speed and increasing torque.
- **Drive motor shaft** is splined and couples directly to the planetary gearbox.

**Market Opportunities**

- **Agriculture** — Augers are an effective work tool around the farm to drill holes for fence posts, pole barn supports and footers for outbuildings.
- **Building/General Construction** — Augers are an essential work tool on many construction sites to drill holes for deck posts and footings, signs and fencing.
- **Landscaping/Landscape Maintenance** — Augers with special tree bits are ideal for preparing holes for tree planting. They are also ideal for school, park, golf course and recreational maintenance departments to drill holes for playground supports, trees and shrubs, fence posts, and signs.
- **Governmental/Municipalities** — Augers with multiple bit sizes are popular work tools to do a wide spectrum of jobs, including digging holes for traffic signs, poles, posts and trees.
- **Rental** — Augers are one of the highest opportunity rental work tool after buckets.
- **Specialty Trades/Utility** — Augers are ideal for electrical, fencing and plumbing contractors when installing lighting, fence posts and gas/water mains.

Augers are typically not a full time work tool, however they are a highly utilized option for specialized applications. They are often used in conjunction with a bucket, set of pallet forks and/or a trencher.

**Auger Bits**

Auger bits are available in both standard and tree bit configurations with standard hardened, reversible teeth and cast/hardened pilot point. Optional hardfaced and carbide inserted teeth and pilot points are available for aggressive boring conditions. Standard bits are available diameters ranging from 6"–36"; tree bits are available in 24" and 36" diameters. Typical digging depth is 48", however for deeper holes, optional 12" and 24" extensions are available. A special HEX to round adapter is also available for customers who use existing round shaft auger bits.

**Machine Compatibility**

Auger Model	Machine Models
<b>A14B</b>	216B2, 226B2, 232B2, 236B2, 242B2, 247B2, 252B2, 257B2, 246C, 256C, 262C, 272C, 277C, 287C, 297C, 279C, 289C, 299C
<b>A19B</b>	216B2, 226B2, 232B2, 236B2, 242B2, 247B2, 252B2, 257B2, 246C, 256C, 262C, 272C, 277C, 287C, 297C, 279C, 289C, 299C
<b>A26B</b>	246C, 256C, 262C, 272C, 277C, 287C, 297C, 279C, 289C, 299C

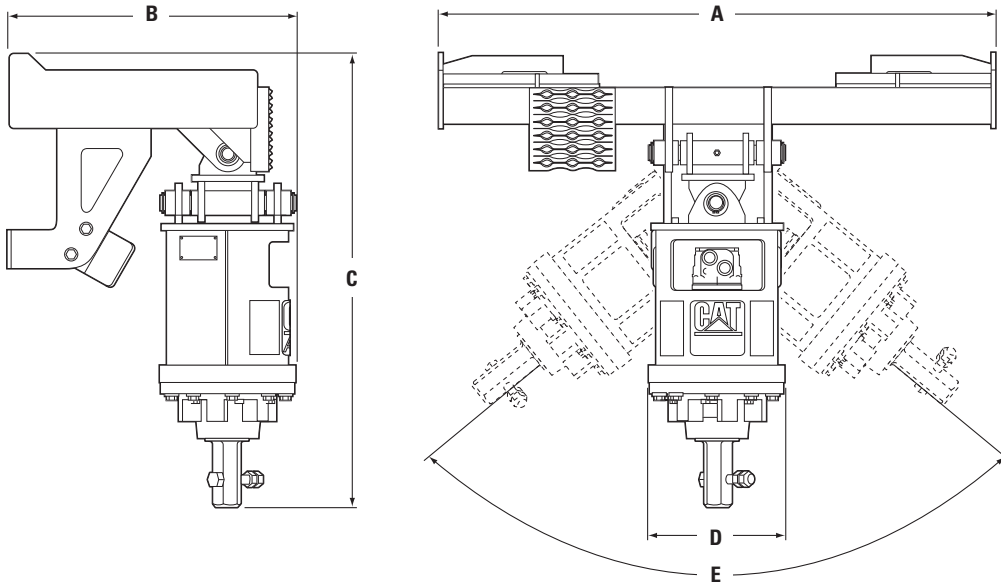

MODEL	A14B		A19B		A26B	
A Overall width with bracket	1152 mm	45"	1152 mm	45"	1152 mm	45"
B Overall length with bracket	598 mm	24"	598 mm	24"	598 mm	24"
C Overall drive unit height	1020 mm	40"	934 mm	37"	978 mm	39"
D Housing diameter	252 mm	10"	252 mm	10"	252 mm	10"
E Swing range	102°		102°		102°	
Drive unit weight with hydraulic lines without bit	101 kg	223 lb	75 kg	165 lb	91 kg	201 lb
Mounting frame weight with clevis	91 kg	201 lb	91 kg	201 lb	91 kg	201 lb
Total weight without bit	192 kg	423 lb	166 kg	366 lb	182 kg	402 lb
Drive method	<b>Gerotor Motor — Direct</b>		<b>Gerotor Motor — Single Planetary Reduction</b>		<b>Gear Motor — Double Planetary Reduction</b>	
Required hydraulic flow range	42-80 L/min	11-21 gpm	42-80 L/min	11-21 gpm	95-130 L/min	25-34 gpm
Optimal hydraulic pressure range	145-230 bar	2103-3336 psi	145-230 bar	2103-3336 psi	207-290 bar	3002-4206 psi
Effective displacement	629.1 cm <sup>3</sup> /rev	38.39 in <sup>3</sup> /rev	250 cm <sup>3</sup> /rev	15.26 in <sup>3</sup> /rev	43.77 cm <sup>3</sup> /rev	2.685 in <sup>3</sup> /rev
Drive shaft torque @ maximum pressure*	2304 N•m	1700 lb-ft	4118 N•m	3037 lb-ft	6826 N•m	5034 lb-ft
Bit speed (drive shaft) @ maximum flow	127 RPM		71 RPM		84 RPM	
HEX output shaft size	51 mm	2"	51 mm	2"	51 mm	2"
Auger bit retention method	<b>Cross bolts/nuts</b>		<b>Cross bolts/nuts</b>		<b>Cross bolts/nuts</b>	
Hydraulic hose	<b>Cat XT-3 ES</b>		<b>Cat XT-3 ES</b>		<b>Cat XT-6 ES</b>	

\*Theoretical values calculated at 100% efficiency.



**A14B Auger**

Theoretical Bit Speed			Theoretical Digging Torque			
L/min	gpm	RPM	bar	psi	N•m	lb-ft
42	11	54	145	2100	1764	1300
45	12	59	152	2200	1848	1362
49	13	64	159	2300	1932	1424
53	14	69	166	2400	2016	1486
57	15	74	172	2500	2100	1548
61	16	79	179	2600	2184	1610
64	17	84	186	2700	2268	1672
68	18	89	193	2800	2352	1734
72	19	94	200	2900	2436	1795
76	20	99	207	3000	2520	1857
80	21	104	214	3100	2604	1919
83	22	109	221	3200	2688	1981
87	23	114	228	3300	2772	2043

**A19B Auger**

Theoretical Bit Speed			Theoretical Digging Torque			
L/min	gpm	RPM	bar	psi	N•m	lb-ft
42	11	38	145	2100	2535	1868
45	12	41	152	2200	2655	1956
49	13	45	159	2300	2776	2045
53	14	48	166	2400	2897	2134
57	15	52	172	2500	3017	2223
61	16	55	179	2600	3138	2312
64	17	59	186	2700	3259	2401
68	18	62	193	2800	3379	2490
72	19	65	200	2900	3500	2579
76	20	69	207	3000	3621	2668
80	21	72	214	3100	3741	2757
83	22	76	221	3200	3862	2846
87	23	79	228	3300	3983	2935

**A26B Auger**

Theoretical Bit Speed			Theoretical Digging Torque			
L/min	gpm	RPM	bar	psi	N•m	lb-ft
95	25	61	207	3000	4719	3492
99	26	64	214	3100	4880	3611
102	27	66	220	3200	5034	3725
106	28	69	227	3300	5191	3841
110	29	71	234	3400	5348	3958
114	30	74	241	3500	5506	4074
118	31	76	248	3600	5663	4191
121	32	79	255	3700	5820	4307
125	33	81	262	3800	5977	4423
129	34	84	269	3900	6135	4540
133	35	86	276	4000	6292	4656
136	36	88	282	4100	6449	4772
140	37	91	289	4200	6607	4889
144	38	93	296	4300	6764	5005
148	39	96	303	4400	6921	5122
152	40	98	310	4500	7079	5238

**Features:**

- **High-strength blades** deliver high cutting action and durability, and also mulch overgrowth.
- **Fully balanced blade carriers** prevent unnecessary vibration.
- **High-strength frame with reinforced corner gussets** provide strength in critical areas.
- **Long life motors** deliver years of high-speed blade performance.
- **Machined and heat treated gears** in sealed gearbox provide reliable, durable transfer of torque from motor to blade carrier.
- **Tapered blade carrier** allows cutter to ride up over stumps and rocks.
- **Galvanized coil chains** provide debris guarding in the front and rear areas to restrict flying debris and material.
- **Heavy-duty skids** allow easy movement of the brushcutter through uneven terrain while maintaining stability of the work tool and machine.
- **Motor protection guard shields** motor and gear box from debris. Removing a set of bolts allows this hinged guard to be moved away for easy access to motor and gear box.
- **Cat XT-3 hose, couplings and O-ring face seals** provide superior, leak-free performance and reliability. All hoses are wrapped with nylon woven cordura sleeving for added operator protection. Hydraulic quick disconnects enable fast tool changes.
- **Quick coupler** with rugged, opposing edge design holds the work tool securely and allows the operator to quickly change from one high performance Cat Work Tool to another.

**Cat Brushcutters** are used for clearing overgrowth from highway medians, utility easements and for initial land clearing for housing, parks and recreational areas.

**Machine Compatibility**

Brushcutter Model	Machine Models
<b>BR160</b>	216B, 226B, 232B, 236B, 242B, 247B, 252B, 257B, 246C, 256C, 262C, 277C, 287C, 297C, 279C, 289C, 299C
<b>BR166</b>	216B, 226B, 232B, 236B, 242B, 247B, 252B, 257B, 246C, 256C, 262C, 277C, 287C, 297C, 279C, 289C, 299C
<b>BR172</b>	216B, 226B, 232B, 236B, 242B, 247B, 252B, 257B, 246C, 256C, 262C, 277C, 287C, 297C
<b>BR272*</b>	226B, 242B, 257B, 279C, 289C, 299C
<b>BR378*</b>	246C, 256C, 262C, 272C, 277C, 287C, 297C, 279C, 289C, 299C

\*Requires high flow or high flow XPS option on machine.

**Skid Steer Loaders**  
**Multi Terrain Loaders**  
**Compact Track Loaders**

**Work Tools**  
 ● **Brushcutters**

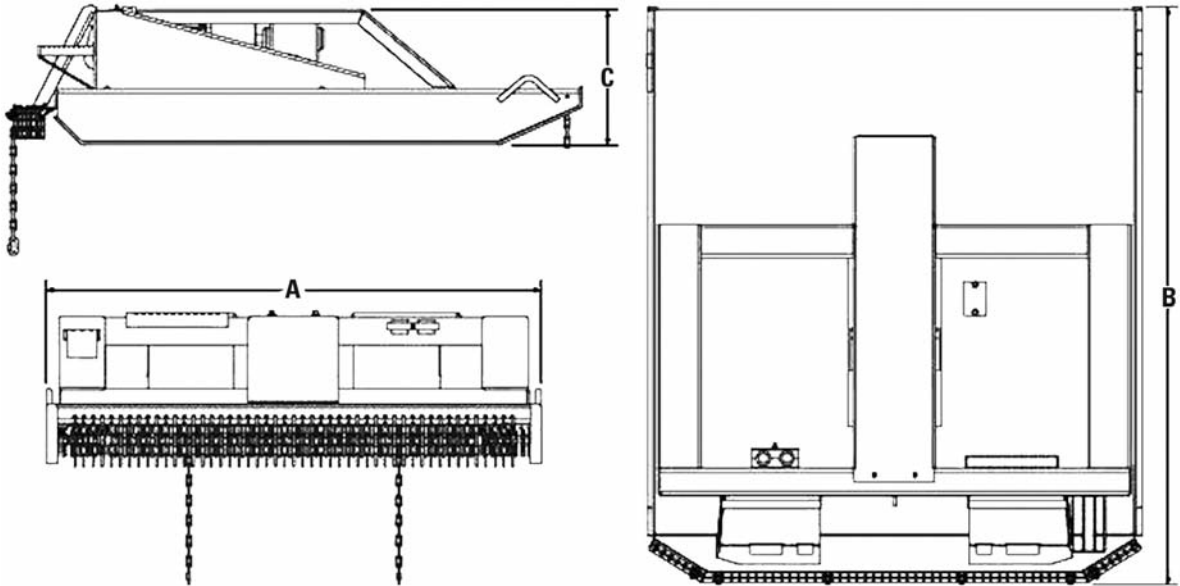

MODEL	BR160		BR166		BR172	
A Overall width	1575 mm	62"	1727 mm	68"	1880 mm	74"
B Overall length	1854 mm	73"	2007 mm	79"	2159 mm	85"
C Overall height	762 mm	30"	762 mm	30"	762 mm	30"
Cutting width	1524 mm	60"	1676 mm	66"	1829 mm	72"
Unit weight	431 kg	950 lb	476 kg	1050 lb	499 kg	1100 lb
Required hydraulic flow range	57-80 L/min	15-21 psi	57-80 L/min	15-21 psi	57-80 L/min	15-21 psi
Optimal hydraulic pressure range	150-228 bar	2176-3300 psi	150-228 bar	2176-3300 psi	150-228 bar	2176-3300 psi
Tip speed range (depends on flow)	3987- 5596 m/min	13,080- 18,360 ft/min	3130- 4395 m/min	10,270- 14,420 ft/min	3417- 4795 m/min	11,210- 15,730 ft/min

MODEL	BR272		BR378	
A Overall width	1880 mm	74"	2032 mm	80"
B Overall length	2159 mm	85"	2311 mm	91"
C Overall height	762 mm	30"	762 mm	30"
Cutting width	1829 mm	72"	1981 mm	78"
Unit weight	508 kg	1120 lb	535 kg	1180 lb
Required hydraulic flow range	76-100 L/min	20-26 psi	76-130 L/min	20-34 psi
Optimal hydraulic pressure range	150-228 bar	2176-3300 psi	150-280 bar	2176-4060 psi
Tip speed range (depends on flow)	4554- 5992 m/min	14,940- 19,660 ft/min	3392- 5800 m/min	11,130- 19,030 ft/min

**Features:**

- **Self-leveling design** automatically levels itself when placed on the ground for consistent depth control without operator adjustments and excellent spoil retention.
- **Two wear resistant skid plates** remain parallel to the ground for optimum stability.
- **Hydraulic side-shift** permits close planing to curbs, walls and other obstructions.
- **Independent left/right depth control** allows maximum drum depths to be adjusted independently on each skid. The gauges are easily viewable from the cab. Independent depth control is mechanical on standard flow planers and hydraulic on high flow planers.
- **Spring tilt and hydraulic tilt** enable planers to oscillate for angled cuts. Tilt is hydraulically controlled on high flow models and spring controlled on standard flow planers.
- **Direct drive on standard flow** models features a variable speed, unidirectional, gerotor style hydraulic motor.
- **Planetary drive on high flow** models features a variable speed, unidirectional, axial piston style hydraulic motor mounted to a double reduction gearbox.
- **Optional concrete bits and water sprinkler kits** are available for all models.
- **Cat XT-3 and medium pressure hose, couplings and O-ring face seals** provide superior, leak-free performance and reliability.
- **Quick coupler** with rugged, opposing edge design holds the work tool securely and allows the operator to quickly change from one high performance Cat Work Tool to another.

**Conical Bits:** Cold planer drums are designed with an optimal bit pattern to provide maximum cutting performance and efficiency, while ensuring superior surface texture. Standard all-purpose tungsten carbide inserted conical bits provide all-purpose planing in most applications.

**Market Opportunities**

- **Infrastructure/Heavy Construction** — Skid steer mounted cold planers are frequently used on bridges to remove pavement where large dedicated planers are restricted due to weight.
- **Concrete/Masonry (Including Asphalt/Paving)** — Cold planers are used extensively by paving contractors in urban and rural settings to remove damaged pavement prior to overlay, remove excess pavement, provide specific surface texture (skid resistance), remove traffic lane stripes and re-establish proper draining characteristics of pavement.
- **Governmental/Municipalities (Street and Road Maintenance)** — Cold planers are ideal for urban road and parking lot maintenance departments to remove cracked or deteriorated pavement, milling bumps or imperfections in expanded pavement.

**Cold planers** are highly utilized work tools for specialized applications. They are often used in conjunction with a bucket and broom.

**Machine Compatibility**

Cold Planer Model	Machine Models
PC203	216B2, 226B2, 232B2, 236B2, 242B2, 247B2, 252B2, 257B2, 246C, 256C, 262C, 277C, 287C, 297C, 279C, 289C, 299C
PC204	226B2, 236B2, 242B2, 252B2, 257B2, 246C, 256C, 262C, 277C, 287C, 297C, 279C, 289C, 299C
PC205*	226B2, 242B2, 252B2, 257B2, 246C, 256C, 262C, 277C, 287C, 297C, 279C, 289C, 299C
PC206*	246C, 256C, 262C, 272C, 277C, 287C, 297C, 279C, 289C, 299C
PC210*	246C, 256C, 262C, 272C, 277C, 287C, 297C, 279C, 289C, 299C

\*Requires high flow or high flow XPS option on machine.

**Skid Steer Loaders  
Multi Terrain Loaders  
Compact Track Loaders**

**Work Tools**  
● **Cold Planers**

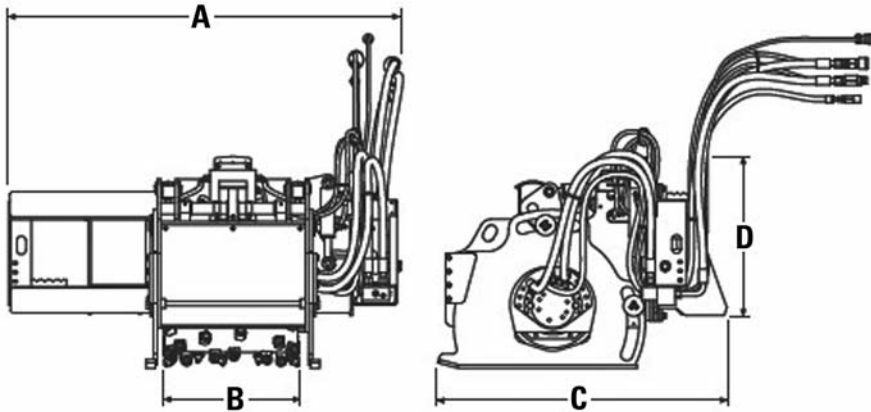

MODEL	PC203		PC204		PC205	
<b>A</b> Overall width	1720 mm	<b>68"</b>	1720 mm	<b>68"</b>	1720 mm	<b>68"</b>
<b>B</b> Maximum drum width	350 mm	<b>14"</b>	450 mm	<b>18"</b>	450 mm	<b>18"</b>
Optional drum widths (depths)	80 (200) mm	<b>3 (8)"</b>	80 (200) mm	<b>3 (8)"</b>	80 (200) mm	<b>3 (8)"</b>
	152 (200) mm	<b>6 (8)"</b>	152 (200) mm	<b>6 (8)"</b>	152 (200) mm	<b>6 (8)"</b>
	203 (200) mm	<b>8 (8)"</b>	203 (200) mm	<b>8 (8)"</b>	305 (200) mm	<b>12 (8)"</b>
	305 (200) mm	<b>12 (8)"</b>	305 (200) mm	<b>12 (8)"</b>	450 (200) mm	<b>18 (8)"</b>
			350 (200) mm	<b>14 (8)"</b>	450 (150) mm	<b>18 (6)"</b>
			400 (200) mm	<b>16 (8)"</b>		
			450 (200) mm	<b>18 (8)"</b>		
			450 (150) mm	<b>18 (6)"</b>		
<b>C</b> Overall height	840 mm	<b>33"</b>	840 mm	<b>33"</b>	990 mm	<b>39"</b>
<b>D</b> Length	1180 mm	<b>46"</b>	1180 mm	<b>46"</b>	1180 mm	<b>46"</b>
Weight	650 kg	<b>1433 lb</b>	690 kg	<b>1521 lb</b>	750 kg	<b>1654 lb</b>
Drive method	<b>Direct drive</b>		<b>Direct drive</b>		<b>Planetary drive</b>	
Required hydraulic flow range	55-100 L/min	<b>14-26 gpm</b>	55-100 L/min	<b>14-26 gpm</b>	80-125 L/min	<b>21-33 gpm</b>
Optimal hydraulic pressure range	160-240 bar	<b>2320-3580 psi</b>	160-240 bar	<b>2320-3580 psi</b>	160-300 bar	<b>2320-4350 psi</b>
Drum torque @ max. pressure	1460 N•m	<b>1077 lb-ft</b>	1460 N•m	<b>1077 lb-ft</b>	2487 N•m	<b>1834 lb-ft</b>
Drum speed @ max. flow	<b>178 RPM</b>		<b>178 RPM</b>		<b>223 RPM</b>	
Bit speed @ max. flow	<b>202 RPM</b>		<b>202 RPM</b>		<b>220 RPM</b>	
Number of conical bits	<b>42 per 350 mm (12") drum</b>		<b>48 per 450 mm (18") drum</b>		<b>48 per 450 mm (18") drum</b>	
Standard bit type	<b>All purpose</b>		<b>All purpose</b>		<b>All purpose</b>	
Maximum depth of cut	127 mm	<b>5"</b>	127 mm	<b>5"</b>	125 mm	<b>5"</b>
Tilt angle range	<b>8.5°</b>		<b>8.5°</b>		<b>8.5°</b>	
Side shift travel	650 mm	<b>26"</b>	650 mm	<b>26"</b>	650 mm	<b>26"</b>

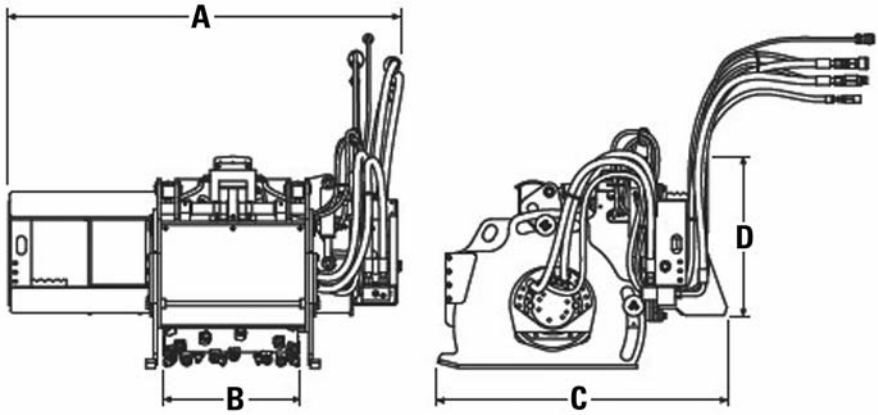

MODEL	PC206		PC210	
A Overall width	1720 mm	68"	1720 mm	68"
B Maximum drum width	600 mm	24"	1000 mm	38"
Optional drum widths (depths)	80 (200) mm 152 (200) mm 305 (200) mm 450 (200) mm 450 (150) mm	3 (8)" 6 (8)" 12 (8)" 18 (8)" 18 (6)"	—	—
C Overall height	950 mm	37"	890 mm	35"
D Length	1265 mm	55"	1130 mm	44"
Weight	906 kg	1998 lb	1080 kg	2381 lb
Drive method	Planetary drive		Planetary drive	
Required hydraulic flow range	95-140 L/min	25-37 gpm	95-180 L/min	25-48 gpm
Optimal hydraulic pressure range	160-300 bar	2320-4350 psi	160-300 bar	2320-4350 psi
Drum torque @ max. pressure	3465 N•m	2556 lb-ft	3339 N•m	2463 lb-ft
Drum speed @ max. flow	160 RPM		240 RPM	
Bit speed @ max. flow	160 RPM		173 RPM	
Number of conical bits	60 per 600 mm (24") drum		78 per 1000 mm (40") drum	
Standard bit type	All purpose		All purpose	
Maximum depth of cut	170 mm	7"	105 mm	4"
Tilt angle range	8.5°		8.5°	
Side shift travel	650 mm	26"	465 mm	18"

**Features:**

- **Two sizes available:** the 1321 mm (52") working width LT13B and the 1854 mm (73") working width LT18B. Both units efficiently utilize the standard flow auxiliary hydraulic horsepower capabilities of Cat Skid Steer Loaders.
- **Direct drive system** features two in-line motors that transmit power directly from the drive motor shaft to the tiller shaft. Power to both ends of the shaft eliminates torque twist and increased system performance.
- **Adjustable skid shoes** provide a working depth range of 25-152 mm (1"-6").
- **High strength medium carbon alloy steel tines** are hardened for maximum strength, durability and wear life in the toughest soil conditions.
- **Cat XT-3 hose and O-ring face seals** are used throughout for superior leak-free performance.

**Market Opportunities**

- **Agriculture** — Landscape tillers provide an effective work tool around the farm or orchard to breakup and condition soil prior to planting.
- **Building/General Construction** — Landscape tillers can be used on construction sites to level soil and remove ruts.
- **Landscaping/Landscape Maintenance** — Landscape tillers are ideal for mixing and composting soils for improved seedbeds, soil stabilization and soil preparation prior to landscaping and laying sod.
- **Governmental/Municipalities** — Landscape tillers are ideal for city maintenance departments and parks to recondition, level and stabilize soil after utility work or prior to yearly landscaping.

**Landscape tillers** are productive work tools for specialized applications. They are often used in conjunction with a bucket, landscape rake and auger.

**Machine Compatibility**

<b>Landscape Tiller Model</b>	<b>Machine Models</b>
<b>LT13B</b>	216B2, 226B2, 232B2, 236B2, 242B2, 247B2, 252B2, 257B2, 246C, 256C, 262C, 272C, 277C, 287C, 297C, 279C, 289C, 299C
<b>LT18B</b>	236B2, 247B2, 252B2, 257B2, 246C, 256C, 262C, 272C, 277C, 287C, 297C, 279C, 289C, 299C

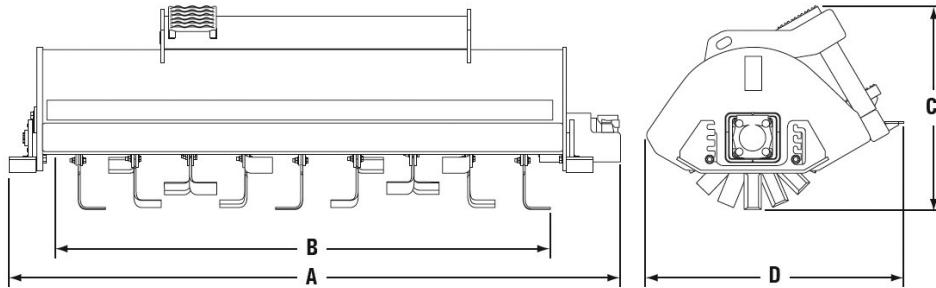

MODEL	LT13B		LT18B	
A Overall width	1788 mm	70.5"	2271 mm	89.5"
B Working width	1321 mm	52"	1847 mm	73"
C Height	755 mm	30"	755 mm	30"
D Length	956 mm	38"	956 mm	38"
Working depth range	25-152 mm	1"-6"	25-152 mm	1"-6"
Weight	340 kg	750 lb	420 kg	926 lb
Drive method	Direct drive		Direct drive	
Number of motors	Two in-line		Two in-line	
Hydraulic flow range	42-83 L/min	11-22 gpm	95-114 L/min	25-30 gpm
Hydraulic pressure range	145-227 bar	2100-3300 psi	207-310 bar	3000-4500 psi
Motor size	305 cm <sup>3</sup>	18.6 in <sup>3</sup>	305 cm <sup>3</sup>	18.6 in <sup>3</sup>
Effective displacement	629.1 cm <sup>3</sup>	38.4 in <sup>3</sup>	629.1 cm <sup>3</sup>	38.4 in <sup>3</sup>
Drum speed @ maximum flow	127 RPM @ 80 L/min	127 RPM @ 21 gpm	127 RPM @ 80 L/min	127 RPM @ 21 gpm
Fasteners	Cat		Cat	
Hydraulic hose	Cat XT-3 ES		Cat XT-3 ES	
Number of tines	24		36	



**Features:**

- **Two sizes available:** the 1321 mm (62") working width LR15B and the 1880 mm (74") working width LR18B. Both units efficiently utilize the standard flow auxiliary hydraulic horsepower capabilities of Cat Skid Steer Loaders.
- **Chain reduction drive system** features #80H roller chain for strength and durability, a variable speed unidirectional gerotor motor for maximum performance and cartridge relief valve for system protection.
- **Durable #2060H conveyor chain** provides strength, durability and long life in a variety of soil conditions.
- **High strength medium carbon alloy steel teeth** are hardened for maximum strength, durability and wear life in the toughest soil conditions.
- **Quick dumping capability** is accomplished with a poppet check valve. Once the hopper bucket is full, simply reverse flow to actuate the rake head and dump the bucket.
- **Cat XT-3 hose and O-ring face seals** are used throughout for superior leak-free performance.

**Market Opportunities**

- **Agriculture** — Landscape rakes provide an effective work tool around the farm or nursery to condition, level and remove rock and foreign material from soil prior to planting.
- **Building/General Construction** — Landscape rakes can be used on construction sites to level and remove debris from soil prior to landscaping and seeding.
- **Demolition** — Landscape rakes provide an excellent means to clean up loose material after the demolition work is complete.
- **Landscaping/Landscape Maintenance** — Landscape rakes are ideal for aerating, conditioning, leveling and removing rocks from soil prior to seeding or laying sod. They also are ideal for conditioning and cleaning baseball fields.

**Landscape rakes** are productive work tools for specialized applications. They are often used in conjunction with a bucket, landscape tiller and auger.

**Machine Compatibility**

The following are the recommended and approved Cat machine/Landscape Rake combinations for maximum system performance.

Landscape Rake Model	Machine Models*
<b>LR15B</b>	216B2, 226B2, 232B2, 236B2, 242B2, 247B2, 252B2, 257B2, 246C, 256C, 262C, 272C, 277C, 287C, 297C, 279C, 289C, 299C
<b>LR18B</b>	236B2, 247B2, 252B2, 257B2, 246C, 256C, 262C, 272C, 277C, 287C, 297C, 279C, 289C, 299C

\*Lift restriction! Do not raise lift arm — work tool hinge higher than 1 m (3 ft) above the ground. Tipping can result.

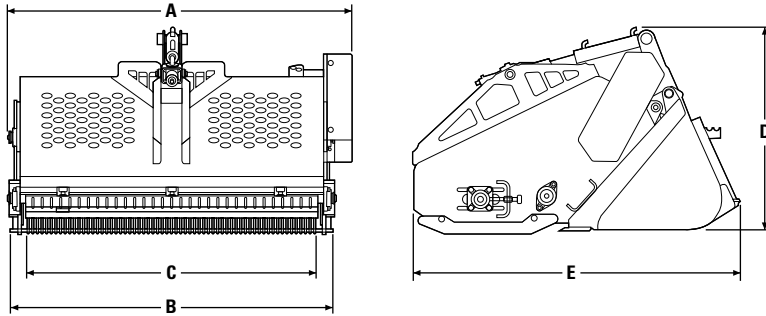

MODEL	LR15B		LR18B	
A Overall width	1683 mm	66"	1990 mm	78"
B Working width	1576 mm	62"	1883 mm	74"
C Raking width	1384 mm	55"	1655 mm	65"
D Height	989 mm	39"	989 mm	39"
E Length	1620 mm	64"	1620 mm	64"
Weight	595 kg	1312 lb	615 kg	1355 lb
Drive method	Chain reduction		Chain reduction	
Drive chain	#80H		#80H	
Conveyor chain	#2060H		#2060H	
Hydraulic flow range	42-83 L/min	11-22 gpm	42-83 L/min	11-22 gpm
Hydraulic pressure range	145-227 bar	2100-3000 psi	145-227 bar	2100-3000 psi
Bucket capacity (struck)*	0.31 m <sup>3</sup>	0.4 yd <sup>3</sup>	0.34 m <sup>3</sup>	0.44 yd <sup>3</sup>
Motor size	305 cm <sup>3</sup>	18.6 in <sup>3</sup>	305 cm <sup>3</sup>	18.6 in <sup>3</sup>
Effective displacement	484.5 cm <sup>3</sup>	29.5 in <sup>3</sup>	484.5 cm <sup>3</sup>	29.5 in <sup>3</sup>
Driven shaft speed	165 RPM @ 80 L/min	165 RPM @ 21 gpm	165 RPM @ 80 L/min	165 RPM @ 21 gpm
Torque @ 230 bar (3336 psi)	1774 N•m	1310 lb-ft	1774 N•m	1310 lb-ft
Fasteners	Cat		Cat	
Hydraulic hose	Cat XT-3 ES		Cat XT-3 ES	
Number of teeth	372		444	
Rock size	19-52 mm	0.75"-6"	19-52 mm	0.75"-6"

\*Rated struck capacities shown as per ISO 7546: 1983 and SAE J742 FEB85.

**Features:**

- **Axial piston hydraulic motor** provides smooth, efficient performance.
- **Rugged mulching head** processes trees up to 200 mm (8 in) diameter for effective forestry clearing applications.
- **Fixed tooth balanced rotor** provides excellent operating efficiency at high speed.
- **Adjustable push frame** is standard equipment on the HM312 and provides the ability to position trees to allow for optimum cutting and efficiency. In forestry operation it also provides operator cab protection.
- **Heavy-duty bearings** extend work tool life.
- **Hydraulically operated front hood** allows trees to be cut when opened and allows dense vegetation to be mulched.
- **V-belt drive** protects the motor against blockages.
- **Rear chain guard protection** reduces spread of material.
- **Rigid, robust tempered steel construction** provides fully guarded protection in tough applications.
- **Cat XT-3 ES hose, couplings and O-ring face seals** provide superior, leak-free performance and reliability. All hoses are wrapped with nylon woven cordura sleeving for added operator protection. Hydraulic quick disconnects enable fast tool changes.
- **Quick coupler** with rugged, opposing edge design holds the work tool securely and allows the operator to quickly change from one high performance Cat Work Tool to another.

The **Cat Mulcher** is designed for high-performance cutting, and mulching vegetation and undergrowth from typical forested terrain. The hydraulic mulcher reduces saplings, shrubs and trees into mulched material, making it ideal for environmental maintenance, such as creating fire lanes. Other applications include: reclaiming untilled land, removing foliage from building construction sites, and shredding pruned material and organic waste for biomass production.

**Machine Compatibility**

<b>Mulcher Model</b>	<b>Machine Models</b>
<b>HM312*</b>	246C, 256C, 262C, 272C, 277C, 287C, 297C, 279C, 289C, 299C
<b>HM315*</b>	246C, 256C, 262C, 272C, 277C, 287C, 297C, 279C, 289C, 299C

\*Requires high flow or high flow XPS option on machine. Debris barrier recommended.

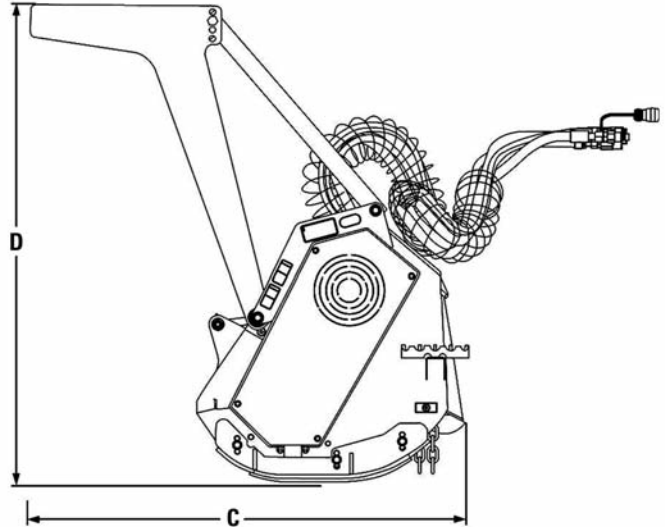
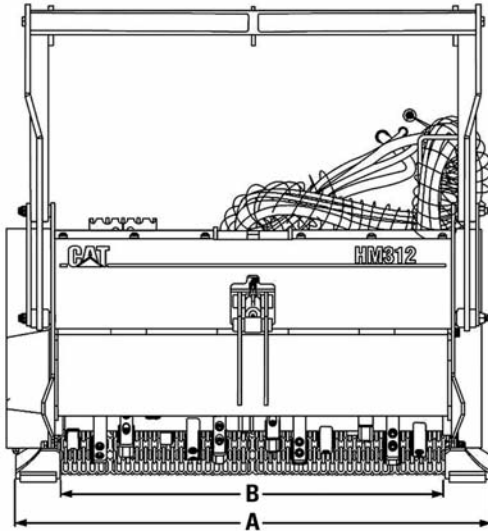

MODEL	HM312		HM315	
A Overall width	1640 mm	65"	1830 mm	72"
B Working width	1210 mm	48"	1450 mm	57"
C Length	1470 mm	58"	1470 mm	58"
D Overall height	1610 mm	63"	1610 mm	63"
Weight	940 kg	2070 lb	1075 kg	2365 lb
Drive method	V-belt drive		V-belt drive	
Hydraulic motor type	Axial piston		Axial piston	
Optimum hydraulic flow range	120-137 L/min	31-36 gpm	120-137 L/min	31-36 gpm
Optimal hydraulic pressure range	195-350 bar	2828-5075 psi	195-350 bar	2828-5075 psi
Drum speed range	1800-2100 RPM		1800-2100 RPM	
Number of teeth	28		34	
Maximum diameter of material to be cut	200 mm	8"	200 mm	8"

**Features:**

- **A heavy-duty frame, pivot plate and attachment plate** are featured for reliable operation in rugged terrain and abusive soil conditions.
- **Pure carbide, blunt shaped teeth** create a dimpled subsurface to ensure the best possible seedbed sub-base fracture pattern.
- **Two-position winged endplates** allow close raking to side walks or foundations. They can remain parallel, even during angling, for smoother plowing.
- **Convenient, heavy-duty, deep skid-resistant step** and a generous cab allow for easy operator entry and exit.
- **Dual independently adjustable gauge wheels** allow for skim passes for over-seeding or adjust to cut drainage grades.
- **Cat XT-3 ES hose, couplings and O-ring face seals** provide superior, leak-free performance and reliability. All hoses are wrapped with nylon woven cordura sleeving for added operator protection. Hydraulic quick disconnects enable fast tool changes.
- **Quick coupler** with rugged, opposing edge design holds the work tool securely and allows the operator to quickly change from one high performance Cat Work Tool to another.

**Cat Power Box Rakes** are ideal for clearing and preparing soil in general construction trench restoration, golf course construction and athletic field maintenance. They offer the versatility to de-thatch, remove old lawns and weeds, grade, level, rake, remove debris and prepare seedbeds with one work tool. Their angling ability allows the operator to windrow collected debris for easy pickup and removal. The consistent milling action creates an ideal seedbed for great germination results, laying the groundwork for a perfect lawn. Wet, dry, weedy, hard and rocky soil can be dried, flattened, pulverized and conditioned for seed in one step.

**Machine Compatibility**

<b>Power Box Rake Model</b>	<b>Machine Models</b>
<b>PR172</b>	216B2, 226B2, 232B2, 236B2, 242B2, 247B2, 252B2, 257B2, 246C, 256C, 262C, 272C, 277C, 287C, 297C, 279C, 289C, 299C
<b>PR184</b>	216B2, 226B2, 232B2, 236B2, 242B2, 247B2, 252B2, 257B2, 246C, 256C, 262C, 272C, 277C, 287C, 297C, 279C, 289C, 299C
<b>PR190</b>	216B2, 226B2, 232B2, 236B2, 242B2, 247B2, 252B2, 257B2, 246C, 256C, 262C, 272C, 277C, 287C, 297C, 279C, 289C, 299C

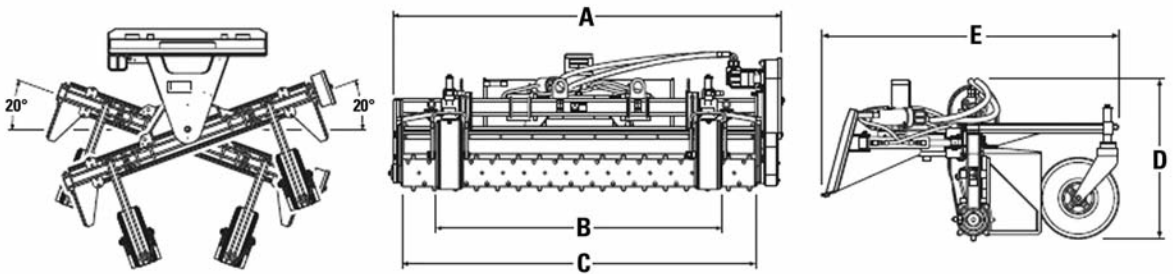

MODEL	PR172		PR184		PR190	
A Overall width	2057 mm	81"	2362 mm	93"	2515 mm	99"
B Width over tires	1386 mm	55"	1732 mm	68"	1845 mm	73"
C Roller width	1829 mm	72"	2134 mm	84"	2286 mm	90"
D Overall height	847 mm	34"	847 mm	34"	953 mm	38"
E Overall length	1626 mm	64"	1626 mm	64"	1626 mm	64"
Raking width at maximum angle	1727 mm	68"	2007 mm	79"	2159 mm	85"
Unit weight (Manual)	408 kg	900 lb	465 kg	1026 lb	588 kg	1296 lb
Unit weight (Hydraulic)	420 kg	925 lb	476 kg	1050 lb	599 kg	1320 lb
Maximum working angle	20°		20°		20°	
Hydraulic flow required	49-83 L/min	13-22 gpm	57-83 L/min	15-22 gpm	58-83 L/min	16-22 gpm

**Features:**

- **Direct drive system** features a variable speed, bidirectional, gerotor style motor that delivers optimal chain speed, chain pull and torque for maximum trenching performance in a broad range of soil types.
- **Durable double standard anti-backflex chain** is standard for strength, durability and long life in all soil types.
- **Standard boom lengths** for all-purpose performance. Replaceable weld-on wear strips extend boom life.
- **Hardfaced, tungsten carbide steel cupped teeth** are standard for long life in many soil conditions. Teeth are spaced for optimum digging performance in most soil.
- **Hydraulic or manual side-shift on the T6B and T9B** provides close trenching flexibility near structures or obstructions.
- **Hydraulic side-shift on the T15B** is controlled from the operator's compartment using the standard flow auxiliary hydraulic circuit selector control.
- **Optional cutting widths and crumber bars** are available for wider trenching requirements and loose material removal.
- **Cat XT-3 hose and O-ring face seals** are used throughout for superior leak-free performance.

**Market Opportunities**

- **Agriculture** — Trenchers provide an effective work tool around the farm or nursery to cut trenches for water lines, electrical cables and other utilities.
- **Building/General Construction** — Trenchers are often used on construction sites to cut trenches for plumbing, electrical, telephone and cable television lines.
- **Landscaping/Landscape Maintenance** — Trenchers are popular landscaping work tools when installing irrigation and water sprinkler systems. They can also be used to remove roots that grow too close to buildings or cart paths. Landscapers, golf course maintenance departments and irrigation contractors are prime users.
- **Specialty Trades/Utilities** — Trenchers are excellent work tools for specialty trades and utility contractors that need to bury water and gas pipe, conduit, electrical, telephone and cable television lines.

**Trenchers** are productive work tools for specialized applications. They are often used in conjunction with a bucket and auger.

### Machine Compatibility

Trencher Model	Machine Models
<b>T6B</b>	216B2, 226B2, 232B2, 236B2, 242B2, 247B2, 252B2, 257B2, 246C, 256C, 262C, 272C, 277C, 287C, 297C
<b>T9B</b>	216B2, 226B2, 232B2, 236B2, 242B2, 247B2, 252B2, 257B2, 246C, 256C, 262C, 272C, 277C, 287C, 297C
<b>T15B*</b>	226B2, 242B2, 257B2, 246C, 256C, 262C, 272C, 277C, 287C, 297C

\*Requires high flow or high flow XPS option on machine.

### T6B/T9B Trencher

Theoretical Drive Shaft Torque			
Pressure		Torque	
bar	psi	N•m	lb-ft
145	2100	848	625
152	2200	889	655
158	2300	924	681
166	2400	971	716
172	2500	1006	741
179	2600	1047	772
186	2700	1088	802
193	2800	1129	832
200	2900	1170	863
207	3000	1211	893
214	3100	1252	923
220	3200	1287	949
227	3300	1328	979

### T15B Trencher

Theoretical Drive Shaft Torque			
Pressure		Torque	
bar	psi	N•m	lb-ft
207	3000	1916	1413
214	3100	1981	1461
220	3200	2036	1501
227	3300	2101	1549
235	3400	2175	1604
242	3500	2240	1652
248	3600	2295	1692
255	3700	2360	1740
262	3800	2425	1788
269	3900	2490	1836
276	4000	2555	1884
283	4100	2619	1931
290	4200	2684	1979
297	4300	2749	2027
304	4400	2814	2075
311	4500	2878	2122



**Skid Steer Loaders  
Multi Terrain Loaders  
Compact Track Loaders**

**Work Tools**  
● **Trenchers**

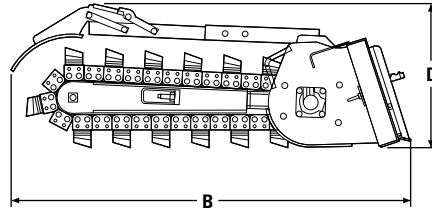
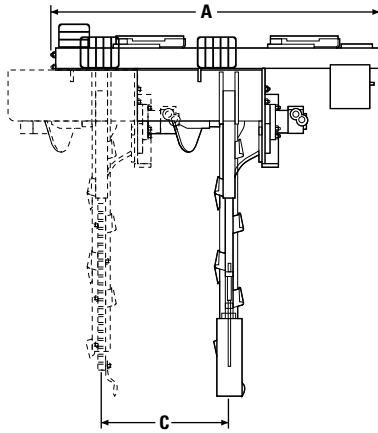

MODEL	T6B		T9B		T15B	
A Overall width	1426 mm	56"	1901 mm	74.8"	1901 mm	74.8"
B Overall length	2348 mm	92"	2705 mm	106.5"	3010 mm	118.5"
C Side shift travel (center to right)	419 mm	16.5"	559 mm	22"	559 mm	22"
D Height	786 mm	30.9"	786 mm	30.9"	786 mm	30.9"
Max. auger clearance	534 mm	21"	534 mm	21"	534 mm	21"
Spoil auger diameter	457 mm	18"	457 mm	18"	457 mm	18"
Standard boom length	914 mm	36"	1219 mm	48"	1524 mm	60"
Weight	397 kg*	875 lb*	551 kg**	1215 lb**	601 kg***	1325 lb***
Required hydraulic flow range	42-83 L/min	11-22 gpm	42-83 L/min	11-22 gpm	95-152 L/min	25-40 gpm
Optimal hydraulic pressure range	145-227 bar	2100-3300 psi	145-227 bar	2100-3300 psi	207-310 bar	3000-4500 psi
Motor size	393.9 cm <sup>3</sup>	24.0 in <sup>3</sup>	393.9 cm <sup>3</sup>	24.0 in <sup>3</sup>	629.1 cm <sup>3</sup>	38.4 in <sup>3</sup>
Theoretical drive shaft torque <sup>1</sup>	1447 N•m	1068 lb-ft	1447 N•m	1068 lb-ft	2905 N•m	2144 lb-ft
Chain pull @ max. pressure <sup>2</sup>	1207 kg	2661 lb	1207 kg	2661 lb	2424 kg	5344 lb
Chain speed @ max. flow <sup>2</sup>	155 m/min	508.5 ft/min	155 m/min	508.5 ft/min	158 m/min	518.3 ft/min
Drive shaft speed @ max. flow <sup>2</sup>	203 RPM		203 RPM		207 RPM	
Optional cutting widths	152, 203, 254, 305 mm	(6", 8", 10", 12")	152, 203, 254, 305 mm	(6", 8", 10", 12")	152, 203, 254, 305 mm	(6", 8", 10", 12")

\*T6B bare configuration, no chain.

\*\*T9B equipped with 1219 mm (48") boom, hydraulic side shift control, double standard anti-backflex chain, 203 mm (8") cutting width, 50/50 carbide/cup chain.

\*\*\*T15B equipped with 1524 mm (60") boom, double standard anti-backflex chain, 203 mm (8") cutting width, 50/50 carbide/cup chain.

<sup>1</sup>Max. Pressure: T6B, T9B — 230 bar (3335 psi), T15B — 290 bar (4206 psi).

<sup>2</sup>Max. Flow: T6B, T9B — 80 L/min (21 gpm), T15B — 130 L/min (34 gpm).

**Features:**

- **Caterpillar exclusive vibratory pod design** delivers desired balance between frequency and amplitude to provide a superior matte finish. Pod-style weight housings are factory sealed for longer bearing life and easy serviceability.
- **Higher compaction forces** provide twice the compaction force of the original design requiring fewer passes for greater productivity.
- **Replaceable rubber mounts** isolate vibration and enhance vibratory capabilities.
- **Durable high-strength steel drums** are roll formed and finish welded for a smoother surface and longer life.
- **Pivoting interface** allows the drum to oscillate  $\pm 15^\circ$  and follow the contour of the ground.
- **Cat XT-3 hose and O-ring face seals** are used throughout for superior leak-free performance.

**Market Opportunities**

- **Building/General Construction** — Vibratory compactors can be used on construction sites to level and compact soil around building foundations after backfilling.
- **Governmental/Municipalities (Street and Road Maintenance)** — Vibratory compactors are useful work tools for compacting soil and crushed rock prior to paving or pouring concrete. They are also useful for compacting small areas of asphalt (pot-hole repair).
- **Landscaping/Landscape Maintenance** — Vibratory compactors are used by landscaping contractors after installing irrigation and water sprinkler systems. Golf course maintenance departments will often use this product to compact greens and fairways.
- **Paving** — Vibratory compactors are used by paving contractors for smaller paving jobs (compacting soil and crushed stone), compacting hot patch (pot hole repair) or compacting material in tight areas where a dedicated roller can't maneuver.
- **Specialty Trades/Utilities** — Vibratory compactors are ideal for compacting back-filled soil after trenching and backhoe work.

**Vibratory compactors** are productive work tools for specialized applications. They are often used in conjunction with a bucket, cold planer and trencher.

**Machine Compatibility**

Vibratory Compactor Model	Machine Models*
CV16B	216B2*, 226B2*, 232B2*, 236B2*, 242B2*, 247B2*, 252B2, 257B2*, 246C, 256C, 262C, 272C, 277C, 287C, 297C, 279C, 289C, 299C
CV18B	252B2, 246C, 256C, 262C, 272C, 277C, 287C, 297C, 279C, 289C, 299C

\*Lift restriction! Do not raise lift arm — work tool coupler interface higher than 1 m (3 ft) above the ground. Tipping can result.

**Skid Steer Loaders  
Multi Terrain Loaders  
Compact Track Loaders**

**Work Tools**  
● **Vibratory Compactors**

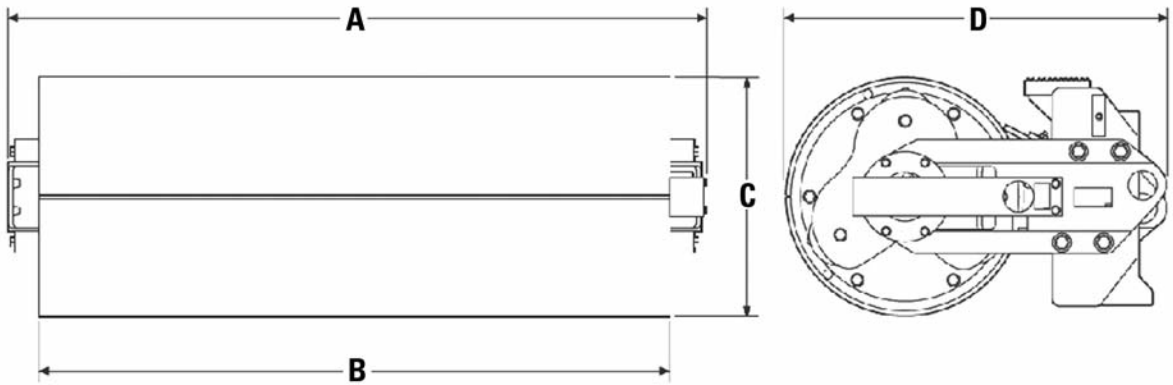

<b>MODEL</b>	<b>CV16B</b>		<b>CV18B</b>	
<b>A</b> Overall width	1854 mm	<b>73"</b>	2032 mm	<b>80"</b>
<b>B</b> Drum width	1676 mm	<b>66"</b>	1854 mm	<b>73"</b>
<b>C</b> Overall height	634 mm	<b>25"</b>	634 mm	<b>25"</b>
<b>D</b> Overall length	1009 mm	<b>40"</b>	1009 mm	<b>40"</b>
Drum diameter	634 mm	<b>25"</b>	634 mm	<b>25"</b>
Weight	924 kg	<b>2037 lb</b>	965 kg	<b>2127 lb</b>
Drive method	<b>Direct drive</b>		<b>Direct drive</b>	
Number of motors	<b>1</b>		<b>1</b>	
Motor size	28.2 cm <sup>3</sup>	<b>1.72 in<sup>3</sup></b>	28.2 cm <sup>3</sup>	<b>1.72 in<sup>3</sup></b>
Hydraulic flow range	42-83 L/min	<b>11-22 gpm</b>	42-83 L/min	<b>11-22 gpm</b>
Hydraulic pressure range	145-227 bar	<b>2100-3300 psi</b>	145-227 bar	<b>2100-3300 psi</b>
Drum oscillation range	<b>±15°</b>		<b>±15°</b>	
Drum frequency @ maximum flow	<b>2946 vibrations/min</b>		<b>2946 vibrations/min</b>	
Dynamic force	5399 kg	<b>11,903 lb</b>	5399 kg	<b>11,903 lb</b>
Amplitude	1.16 mm	<b>0.046"</b>	1.09 mm	<b>0.043"</b>

**Features:**

- **Pickup Brooms** sweep and deposit material into an integrated hopper bucket for easy removal and dumping. Bi-directional capabilities of the bristles allow Pickup and Utility Brooms to sweep in forward or reverse machine travel. Optimum sweeping style is in forward travel, resulting in over-the-brush pickup. Certain conditions require a dust pan style of sweeping, done in reverse travel.
- **Utility Brooms** sweep and collect light debris on smooth surfaces in forward or reverse travel. They can be adjusted for greater bristle down-force in tough applications such as sweeping course material out of a cold planer cut.
- **Angle Brooms** use a single variable speed, unidirectional gerotor style hydraulic motor, contained in a protective housing. They use a windrowing action to move loose debris ahead and to the side of the surface being swept. They can be oriented straight or angled up to 30° left or right of center in forward travel.
- **Direct drive motors** provide maximum performance and durability. Pickup and Utility Brooms use a single variable speed, bidirectional gerotor style hydraulic motor, contained in a special housing that is adjustable to compensate for bristle wear. Angle brooms use a single variable speed unidirectional gerotor style hydraulic motor contained in a protective housing.
- **Polypropylene/wire convoluted brushes** provide optimum results for sweeping. Optional all-polypropylene and all-steel wire convoluted brushes are available for specialty applications. Convoluted brush sections are available in half-kits for easy maintenance and quick replacement.
- **Drop core design** allows for quick bristle replacement without removing hydraulic hoses.
- **Quick coupler** with rugged, opposing edge design holds the work tool securely and allows the operator to quickly change from one high performance Cat Work Tool to another.

**Market Opportunities**

- **Building/General Construction** — Brooms are often found on construction sites once the construction is complete to remove and collect dirt, rock and other construction debris from driveways, sidewalks and streets.

- **Demolition** — Brooms are ideal for collecting loose dirt and debris from demolition sites.
- **Governmental/Municipalities (Street and Road Maintenance)** — Brooms are useful work tools for cleaning city streets, sidewalks and parking areas. Airport maintenance is another popular application.
- **Industrial/Recycling** — Pickup brooms are excellent for cleaning factory floors or industrial pavements.
- **Landscaping/Landscape Maintenance** — Brooms are used by landscaping contractors to clean paved surfaces after the landscaping is complete. Golf course maintenance departments will often use this product to clean cart paths, parking lots and even turf.
- **Paving** — Pickup brooms are often used by paving contractors to sweep and collect milled asphalt and concrete. Angle brooms are used to clean milled surfaces.
- **Specialty Trades/Utilities** — Brooms are often utilized by specialty trades and utility contractors to clean up after trenching and backhoe work.

**Pickup brooms** are productive work tools for specialized applications. They are often used in conjunction with a bucket, cold planer and trencher.

**Machine Compatibility**

Broom Model	Machine Models
BP15B	216B2, 226B2, 232B2, 236B2, 242B2, 247B2, 252B2, 257B2, 246C, 256C, 262C, 272C, 277C, 287C, 297C, 279C, 289C, 299C
BP18B	232B2, 236B2, 242B2, 252B2, 257B2, 246C, 256C, 262C, 272C, 277C, 287C, 297C, 279C, 289C, 299C
BA18	216B2, 226B2, 232B2, 236B2, 242B2, 247B2, 252B2, 257B2, 246C, 256C, 262C, 272C, 277C, 287C, 297C, 279C, 289C, 299C
BU115	216B2, 226B2, 232B2, 236B2, 242B2, 247B2, 252B2, 257B2, 246C, 256C, 262C, 272C, 277C, 287C, 297C, 279C, 289C, 299C
BU118	232B2, 236B2, 242B2, 252B2, 257B2, 246C, 256C, 262C, 272C, 277C, 287C, 297C, 279C, 289C, 299C

**Skid Steer Loaders**  
**Multi Terrain Loaders**  
**Compact Track Loaders**

**Work Tools**  
 ● Brooms

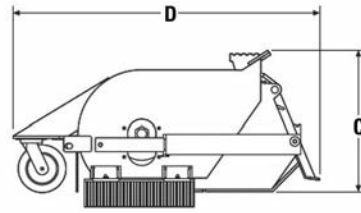
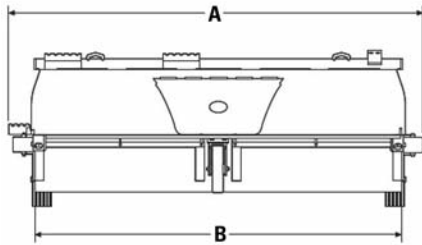

**Pickup Brooms**

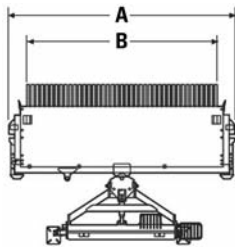

**Angle Brooms**

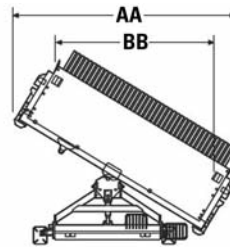
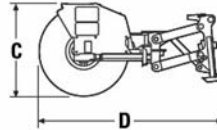

<b>MODEL</b>	<b>BP15B Pickup Broom</b>		<b>BP18B Pickup Broom</b>		<b>BA18 Angle Broom</b>	
<b>A</b> Overall width	1912 mm	75"	2217 mm	87"	2312 mm	91"
<b>AA</b> Overall width angled*	—	—	—	—	2328 mm	92"
<b>B</b> Sweeping width	1524 mm	60"	1829 mm	72"	2134 mm	84"
<b>BB</b> Sweeping width angled*	—	—	—	—	1702 mm	67"
<b>C</b> Height	754 mm	30"	754 mm	30"	845 mm	33"
<b>D</b> Length	1632 mm	64"	1575 mm	62"	1676 mm	66"
Weight**	435 kg	960 lb	468 kg	1032 lb	409 kg	901 lb
Drive method	<b>Direct drive</b>		<b>Direct drive</b>		<b>Direct drive</b>	
Number of motors	<b>One</b>		<b>Two in-line</b>		<b>One</b>	
Motor size	250 cm <sup>3</sup>	15.3 in <sup>3</sup>	200 cm <sup>3</sup> each	12.2 in <sup>3</sup> each	410 cm <sup>3</sup>	24.9 in <sup>3</sup>
Hydraulic flow range	30-83 L/min	8-22 gpm	30-80 L/min	8-22 gpm	42-83 L/min	11-22 gpm
Hydraulic pressure range	145-227 bar	2100-3300 psi	145-227 bar	2100-3300 psi	145-227 bar	2100-3300 psi
Rated brush speed @ maximum flow	<b>190 RPM</b>		<b>190 RPM</b>		<b>190 RPM</b>	
Hopper capacity***	0.42 m <sup>3</sup>	0.55 yd <sup>3</sup>	0.45 m <sup>3</sup>	0.59 yd <sup>3</sup>	—	—
Fasteners	<b>Cat</b>		<b>Cat</b>		<b>Cat</b>	
Hydraulic hose	<b>Cat XT-3 ES</b>		<b>Cat XT-3 ES</b>		<b>Cat XT-3 ES</b>	
Brush diameter	660 mm	26"	660 mm	26"	813 mm	32"
Brush head retention	<b>Dual chain/ loader arm bracket</b>		<b>Dual chain/ loader arm bracket</b>		—	
Brush material (standard)	<b>Replaceable polypropylene/ steel wire sections</b>		<b>Replaceable polypropylene/ steel wire sections</b>		<b>Replaceable polypropylene/ steel wire sections</b>	

\*30° right or left.

\*\*Without gutter brush.

\*\*\*Rated struck capacities shown as per ISO 7546: 1983 and SAE J742 FEB85.

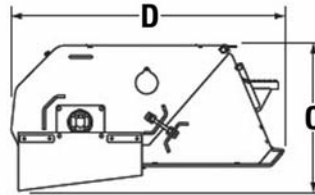
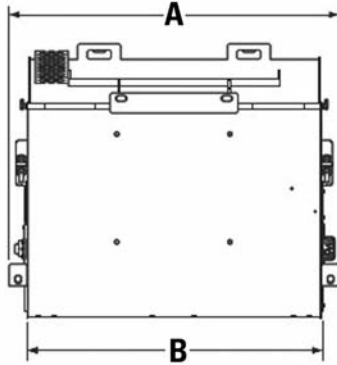

Utility Brooms

MODEL	BU115 Utility Broom		BU118 Utility Broom	
A Overall width	1810 mm	71"	2115 mm	83"
B Sweeping width	1510 mm	59"	1865 mm	73"
C Height	1920 mm	76"	2225 mm	88"
D Length	1490 mm	59"	1490 mm	59"
Weight	410 kg	904 lb	450 kg	992 lb
Drive method	Direct drive		Direct drive	
Number of motors	1		1	
Motor size	393 cm <sup>3</sup>	24 in <sup>3</sup>	393 cm <sup>3</sup>	24 in <sup>3</sup>
Hydraulic flow range	30-83 L/min	8-22 gpm	30-83 L/min	8-22 gpm
Hydraulic pressure range	145-227 bar	2100-3300 psi	145-227 bar	2100-3300 psi
Rated brush speed @ maximum flow	190 RPM		190 RPM	
Hopper capacity*	0.42 m <sup>3</sup>	0.55 yd <sup>3</sup>	0.49 m <sup>3</sup>	0.64 yd <sup>3</sup>
Fasteners	Cat		Cat	
Hydraulic hose	Cat XT-3 ES		Cat XT-3 ES	
Brush diameter	660 mm	26"	660 mm	26"
Brush material (standard)	Replaceable polypropylene sections		Replaceable polypropylene sections	
Brush material (optional)	Replaceable steel wire sections		Replaceable steel wire sections	

\*Rated struck capacities shown as per ISO 7546: 1983 and SAE J742 FEB85.

**Features:**

- **Two direct drive models, the standard flow SG16B and the high flow SG18B** feature a variable speed, unidirectional motor that is matched to the Cat Skid Steer Loader’s auxiliary hydraulic horsepower capabilities. Provides high torque for efficient grinding performance.
- **Heavy-duty 550 mm (22") cutting wheel and 32 bolt-on carbide teeth** provide maximum durability and cutting efficiency.
- **Heavy-duty, dual height, pivoting stand feet** provide a stable platform when grinding.
- **Standard hydraulic cutting wheel swing** (full 70 degrees) and extension [279 mm (11 in) max.].
- **Hydraulic depth control on SG18B, depth control on SG16B** is manually adjustable using a 3-position depth control bar.
- **Extension slider rods** are chrome plated for long life.
- **Cat XT-3 and medium pressure hose, couplings and O-Rings.**

**Market Opportunities**

- **Landscaping/Landscaping Maintenance** — Stump grinders are ideal for economically removing tree stumps in residential, commercial and agricultural settings.
- **Rental** — Stump grinders are a high opportunity rental work tool for lawn care and for clean up after natural disasters such as tornadoes and hurricanes where many trees are damaged.

**Stump grinders** are productive work tools for specialized applications. Maneuverability and compact size compared to tow behind stump grinders lend it be to very popular in lawn care and golf course maintenance.

**Machine Compatibility**

<b>Stump Grinder Model</b>	<b>Machine Models</b>
<b>SG16B</b>	216B2, 226B2, 232B2, 236B2, 242B2, 247B2, 252B2, 257B2, 246C, 256C, 262C, 272C, 277C, 287C, 297C, 279C, 289C, 299C
<b>SG18B*</b>	246C, 256C, 262C, 272C, 277C, 287C, 297C, 279C, 289C, 299C

\*Requires high flow or high flow XPS option on machine.

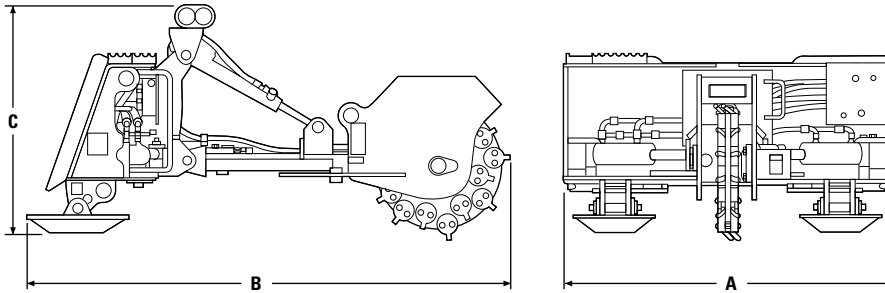

MODEL	SG16B		SG18B	
A Overall width	1175 mm	46"	1175 mm	46"
B Overall length	1737 mm	69"	1737 mm	69"
C Overall height	730 mm	30"	813 mm	32"
Unit weight	379 kg	775 lb	400 kg	840 lb
Drive method	<b>Gerotor Motor — Direct</b>		<b>Gerotor Motor — Direct</b>	
Required hydraulic flow	42-83 L/min	<b>11-22 gpm</b>	95-114 L/min	<b>25-30 gpm</b>
Optimal hydraulic pressure	145-227 bar	<b>2100-3300 psi</b>	207-310 bar	<b>3000-4500 psi</b>
Effective displacement	80 cm <sup>3</sup>	<b>4.9 in<sup>3</sup></b>	100 cm <sup>3</sup>	<b>6.2 in<sup>3</sup></b>
Drive shaft torque @ maximum pressure	295 N•m @ 230 bar	<b>218 lb-ft @ 3336 psi</b>	469 N•m @ 290 bar	<b>346 lb-ft @ 4206 psi</b>
Cutting head speed (drive shaft) @ maximum flow	993 RPM @ 80 L/min	<b>993 RPM @ 21 gpm</b>	1280 RPM @ 130 L/min	<b>1280 RPM @ 34 gpm</b>
Cutting wheel width (with teeth)	83 mm	3.3"	83 mm	3.3"
Cutting wheel diameter (with teeth)	550 mm	22"	550 mm	22"
Cutting width (full swing range)	1524 mm	60"	1524 mm	60"
Cutting head swing range		<b>70°</b>		<b>70°</b>
Cutting height (above ground)	470 mm	18.5"	470 mm	18.5"
Cutting height (below ground)	547 mm	21.5"	547 mm	21.5"
Cutting head extension	280 mm	11"	280 mm	11"
Fasteners	<b>Cat</b>		<b>Cat</b>	
Hydraulic hose	<b>XT-3 ES, medium pressure</b>		<b>XT-6 ES, medium pressure</b>	
Ground Engaging Tools (GET)	<b>12.7 mm (½") square bolt-on carbide teeth</b>		<b>12.7 mm (½") square bolt-on carbide teeth</b>	
Number of carbide teeth per cutting wheel	<b>32</b>		<b>32</b>	



**SG16B Stump Grinder**

Theoretical Drive Shaft Torque			
Pressure		Torque	
bar	psi	N•m	lb-ft
145	2100	186	137
152	2200	194	143
158	2300	204	150
166	2400	212	156
172	2500	222	163
179	2600	230	169
186	2700	239	176
193	2800	248	182
200	2900	257	189
207	3000	265	195
214	3100	275	202
220	3200	283	208
227	3300	292	215

**SG18B Stump Grinder**

Theoretical Drive Shaft Torque			
Pressure		Torque	
bar	psi	N•m	lb-ft
207	3000	336	247
214	3100	347	255
221	3200	358	263
227	3300	370	272
234	3400	381	280
241	3500	392	288
248	3600	403	296
255	3700	413	304
262	3800	426	313
269	3900	437	321
276	4000	447	329
282	4100	458	337
289	4200	471	346
296	4300	481	354
303	4400	492	362
310	4500	503	370

**SG16B Stump Grinder**

Theoretical Cutting Head Speed (Drive Shaft)		
Flow		Cutting Head Speed
L/min	gpm	RPM
42	11	519
45	12	566
49	13	613
53	14	660
57	15	707
61	16	754
64	17	801
68	18	849
72	19	896
76	20	943
80	21	990
83	22	1037

**SG18B Stump Grinder**

Theoretical Cutting Head Speed (Drive Shaft)		
Flow		Cutting Head Speed
L/min	gpm	RPM
95	25	931
99	26	969
102	27	1006
106	28	1043
110	29	1080
114	30	1118
118	31	1155
122	32	1192
125	33	1230

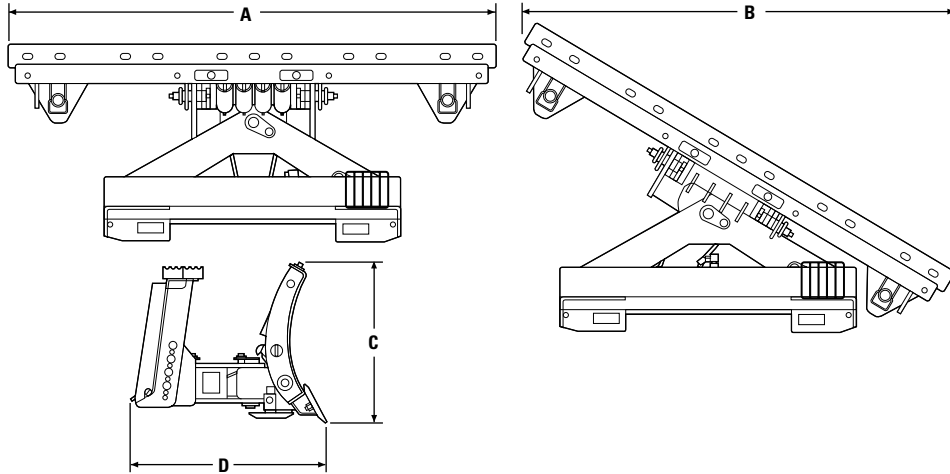

<b>A</b> Overall width (straight)*	1829 mm	<b>72"</b>	2134 mm	<b>84"</b>
<b>B</b> Working width, fully angled	1685 mm	<b>66"</b>	1949 mm	<b>78"</b>
<b>C</b> Height	614 mm	<b>24"</b>	614 mm	<b>24"</b>
<b>D</b> Length	753 mm	<b>30"</b>	753 mm	<b>30"</b>
Weight	313 kg	<b>690 lb</b>	331 kg	<b>730 lb</b>
Adjustable cutting depth (three positions — 25.4 mm (1") increments)	0, 25 and 51 mm	<b>0", 1" and 2"</b>	0, 25 and 51 mm	<b>0", 1" and 2"</b>
Maximum blade angle — (right or left of center)		<b>30°</b>		<b>30°</b>
Maximum blade trip angle		<b>60°</b>		<b>60°</b>

\*Measured from moldboard edges; overall width is approximately 50 mm (2") wider with bolt-on edge.

**Skid Steer Loaders  
Multi Terrain Loaders  
Compact Track Loaders**

**Work Tools**  
● Backhoes

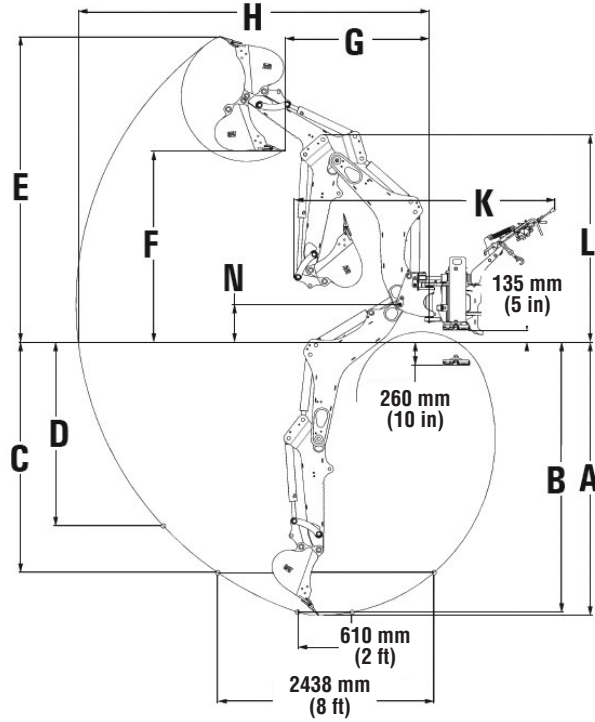

MODEL	BH150		BH160	
<b>Operational Specifications</b>				
A Digging depth maximum	3074 mm	121"	3074 mm	121"
B Digging depth 0.61 m (2') flat bottom	3040 mm	120"	3040 mm	120"
C Digging depth 2.44 m (8') flat bottom	2593 mm	102"	2593 mm	102"
D Straight wall digging depth	2064 mm	81"	2064 mm	81"
E Overall operating height	3442 mm	136"	3442 mm	136"
F Loading height	2147 mm	85"	2147 mm	85"
G Loading reach	1628 mm	64"	1628 mm	64"
H Reach from swing pivot	3955 mm	156"	3955 mm	156"
K Overall length	2776 mm	109"	2936 mm	116"
Side shift length	822 mm	32"	974 mm	38"
Swing arc		180°		180°
Bucket rotation		192°		192°
Bucket breakout force	3241 kg	7146 lb	3241 kg	7146 lb
Stick breakout force	1560 kg	3439 lb	1560 kg	3439 lb
<b>Transport Dimensions</b>				
L Transport height	2336 mm	92"	2336 mm	92"
N Boom pivot height	425 mm	17"	425 mm	17"
Ground clearance	85.7 mm	3.4"	85.7 mm	3.4"
Operating weight	1023 kg	2256 lb	1047 kg	2309 lb

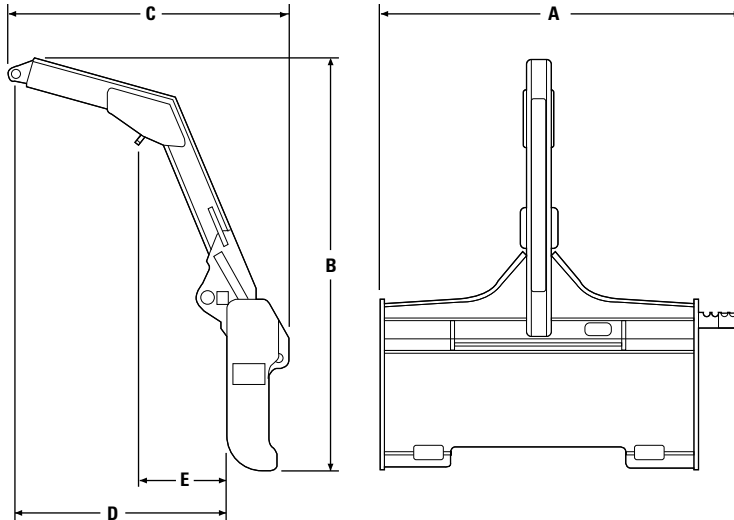

A Width with side step	1309 mm	52"
B Height	1473 mm	58"
C Length	1016 mm	40"
D Load length (end point)	768 mm	30"
E Load length (mid point)	311 mm	12"
Rated structural capacity*	907 kg	2000 lb
Maximum reach (horizontal)**	2134 mm	84"
Weight	127 kg	280 lb

\*Rated structural capacity is the maximum load that can be carried by the work tool and does not imply that the specific host machine has the tipping capacity to lift the load. Refer to the Cat Skid Steer Loader and Multi Terrain Loader Operation and Maintenance Manual (OMM) for Cat Skid Steer Loader and Multi Terrain Loader rated operating capacity with Material Handling Arm.

\*\*Maximum horizontal reach is measured from the front tire with the loader arms approximately 1.5 m (5') off the ground and work tool tilted forward approximately 68 degrees at the end point.

**Skid Steer Loaders**  
**Multi Terrain Loaders**  
**Compact Track Loaders**

**Work Tools**  
 ● **Snow Blowers**

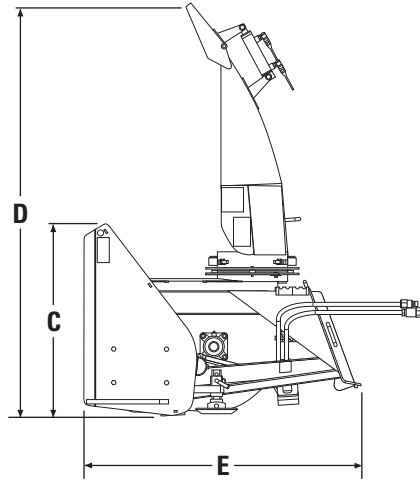
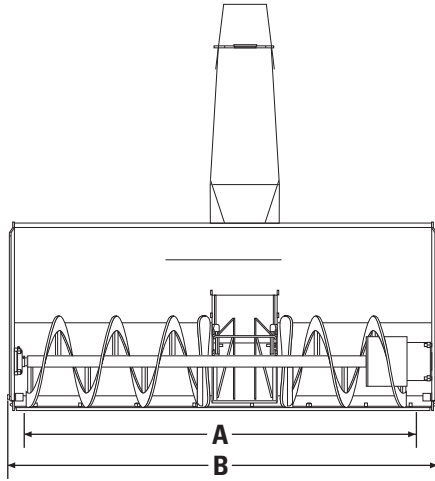

MODEL	SR117		SR118		SR121	
A Intake width	1702 mm	67"	1854 mm	73"	2159 mm	85"
B Overall width	1765 mm	69.5"	1918 mm	75.5"	2223 mm	87.5"
C Cutting height	609.6 mm	24"	812.8 mm	32"	914.4 mm	36"
D Overall height	1582 mm	62.3"	1582 mm	62.3"	1735 mm	68.3"
E Overall length	1148 mm	45.2"	1209 mm	47.6"	1440 mm	56.7"
Weight	404.5 kg	890 lb	450 kg	990 lb	555 kg	1220 lb
Maximum throw distance*	9.1 m	30'0"	12.2 m	40'0"	12.2 m	40'0"
Auger diameter	305 mm	12"	406 mm	16"	457 mm	18"
Impeller/fan diameter	517 mm	20"	517 mm	20"	679 mm	27"
Chute rotation	180°		180°		180°	
Required hydraulic flow	53-76 L/min	14-20 gpm	68-83 L/min	18-22 gpm	72-87 L/min	19-23 gpm

MODEL	SR318		SR321	
A Intake width	1584 mm	73"	2159 mm	85"
B Overall width	1918 mm	75.5"	2223 mm	87.5"
C Cutting height	812 mm	32"	915 mm	36"
D Overall height	1582 mm	62.3"	1735 mm	68.3"
E Overall length	1209 mm	47.6"	1440 mm	56.7"
Weight	450 kg	990 lb	555 kg	1220 lb
Maximum throw distance*	13.7 m	45'0"	13.7 m	45'0"
Auger diameter	406 mm	16"	457 mm	18"
Impeller/fan diameter	517 mm	20"	679 mm	27"
Chute rotation	180°		180°	
Required hydraulic flow	98-130 L/min	26-34 gpm	98-130 L/min	26-34 gpm

\*Theoretical values calculated at 100% efficiency.

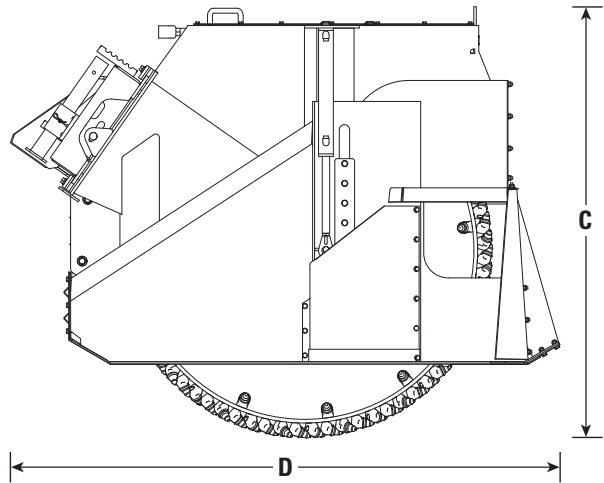
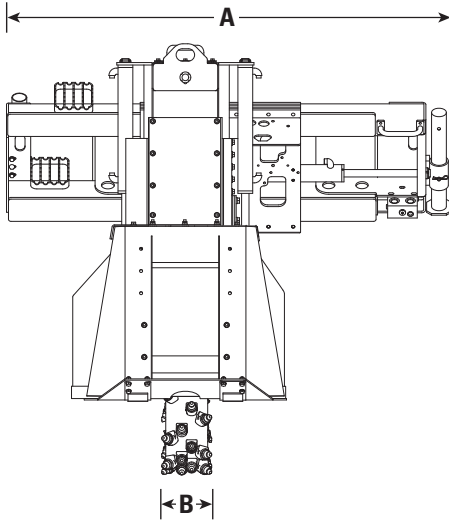

MODEL	SW45 80 mm (3")		SW45 160 mm (6")		SW45 200 mm (8")		SW60 160 mm (6")		SW60 200 mm (8")	
A Overall width	1803 mm	71"	1803 mm	71"	1803 mm	71"	1866 mm	74"	1866 mm	74"
B Maximum wheel width	80 mm	3"	160 mm	6"	200 mm	8"	160 mm	6"	200 mm	8"
C Overall height	1440 mm	57"	1435 mm	56"	1435 mm	56"	1746 mm	69"	1746 mm	69"
D Length	1992 mm	78"	1992 mm	78"	1992 mm	78"	2230 mm	88"	2230 mm	88"
Weight	1004 kg	2213 lb	932 kg	2054 lb	961 kg	2118 lb	1169 kg	2577 lb	1192 kg	2628 lb
Trench cleaning device	No		Yes		Yes		Yes		Yes	
Drive method	Piston motor/ Planetary		Piston motor/ Planetary		Piston motor/ Planetary		Piston motor/ Planetary		Piston motor/ Planetary	
Required hydraulic flow range	90- 160 L/min	24- 42 gpm	90- 160 L/min	24- 42 gpm	90- 160 L/min	24- 42 gpm	100- 160 L/min	26- 42 gpm	100- 160 L/min	26- 42 gpm
Optimal hydraulic pressure range	180- 300 bar	2611- 4351 psi	180- 300 bar	2611- 4351 psi	180- 300 bar	2611- 4351 psi	180- 300 bar	2611- 4351 psi	180- 300 bar	2611- 4351 psi
Wheel torque @ maximum pressure	1131 N•m	832 lb-ft	1429 N•m	1051 lb-ft	1429 N•m	1051 lb-ft	1429 N•m	1051 lb-ft	1429 N•m	1051 lb-ft
Wheel speed @ maximum flow	267 RPM		212 RPM		212 RPM		212 RPM		212 RPM	
Bit speed @ maximum flow	395 m/min	1295 ft/min	313 m/min	1026 ft/min	313 m/min	1026 ft/min	313 m/min	1026 ft/min	313 m/min	1026 ft/min
Conical bits	64 per wheel		56 per wheel		62 per wheel		96 per wheel		96 per wheel	
Standard bit type	Concrete		Concrete		Concrete		Concrete		Concrete	
Optional bit type	All purpose		All purpose		All purpose		All purpose		All purpose	
Maximum depth of cut	450 mm	18"	450 mm	18"	450 mm	18"	600 mm	24"	600 mm	24"
Sideshift travel	650 mm	26"	650 mm	26"	650 mm	26"	650 mm	26"	650 mm	26"



# EXCAVATORS

## CONTENTS

### EXCAVATORS

Specifications	4-2
Shipping Dimensions	4-23
Major Component Weights	4-35
Range Dimensions:	
One-piece Boom	4-43
Variable Adjustable Boom	4-63
Hydraulic Adjustable Boom	4-64
Lifting Capacity (definition)	4-66
Lifting Capacity at Ground Level (charts)	4-68
Bucket Capacity (definition)	4-106
Curl and Crowd Forces	4-106
Bucket Specifications	4-121
New Nomenclature for	
Hydraulic Excavator Buckets	4-123
Bucket Types	4-125
Bucket Sales Support	4-129
Working Weights (bucket & payload)	4-130
Equipping Excavators:	
Long Reach	4-134
Long Reach Excavation	4-136
Super Long Reach	4-139
Short Reach	4-141
Telescopic Stick	4-143
Ultra-High Demolition Arrangements	4-145
Demolition Arrangements	4-157
Machine Selection (tracks vs. wheels)	4-159
Shoe Selection and Ground Pressure	4-160
Quick Coupler Systems	4-164
Ripping & Loading in Quarries	4-169
Major Attachment Summary	4-172
Work Tools	4-181
Cycle Time Estimating Charts	4-182
Machine Operation	4-185
Maximizing Production with a	
Mass Excavator	4-185
Selecting a Mass Excavator	4-186
Earthmoving Production	4-188
Production Estimating Tables	4-190
Trenching Production	4-192
Front Shovels (Belgium Sourced)	4-199
Specifications	4-199
Digging Envelopes	4-200
General Dimensions	4-201

### MATERIAL HANDLING ARRANGEMENTS

330D Waste Handler	
Range Diagram and Specifications	4-204
Lifting Capacities	4-205
M318D MH, M322D MH	
Range Dimensions	4-206
M318D MH Lifting Capacities	4-207
M322D MH Lifting Capacities	4-208
M325D MH, M325D LMH — Belgium Sourced	
Dimensions and Weights	4-209
Range Dimensions	4-209
Lifting Capacities	4-210
325D MH	
Range Diagrams and Specifications	4-218
Lifting Capacities	4-219
330D MH	
Range Diagrams and Specifications	4-221
Lifting Capacities	4-222
345C MH	
Range Diagrams and Specifications	4-224
Lifting Capacities	4-225
385C MH	
Range Diagrams and Specifications	4-227
Lifting Capacities	4-228
Magnet Selection	4-230
Grapple Selection	4-230
Ferrous Scrap Specifications	4-231





**301.6C**



**301.8C**

MODEL	301.6C		301.8C	
Sourcing	U.K.		U.K.	
Flywheel Power	13.5 kW	<b>18.1 hp</b>	13.5 kW	<b>18.1 hp</b>
Operating Weight*	1720 kg	<b>3792 lb</b>	1785 kg	<b>3935 lb</b>
Bucket Capacity Range (heaped)	0.018-0.056 m <sup>3</sup>	<b>0.023-0.073 yd<sup>3</sup></b>	0.018-0.056 m <sup>3</sup>	<b>0.023-0.073 yd<sup>3</sup></b>
Engine Model	<b>Mitsubishi L3E</b>		<b>Mitsubishi L3E</b>	
Rated Engine RPM	<b>2400</b>		<b>2400</b>	
No. of Cylinders	<b>3</b>		<b>3</b>	
Bore	76 mm	<b>2.99"</b>	76 mm	<b>2.99"</b>
Stroke	70 mm	<b>2.76"</b>	70 mm	<b>2.76"</b>
Displacement	952 cm <sup>3</sup>	<b>58.1 in<sup>3</sup></b>	952 cm <sup>3</sup>	<b>58.1 in<sup>3</sup></b>
Max. Implement Hydraulic Pump Output at Rated RPM	2 × 18.9/ 1 × 14.6 L/min	2 × <b>5.2</b> / 1 × <b>3.9 gpm</b>	2 × 18.9/ 1 × 14.6 L/min	2 × <b>5.2</b> / 1 × <b>3.9 gpm</b>
Relief Valve Settings:				
Implement Circuits	20.6 mPa	<b>2988 psi</b>	20.6 mPa	<b>2988 psi</b>
Travel Circuits	20.6 mPa	<b>2988 psi</b>	20.6 mPa	<b>2988 psi</b>
Swing Circuits	17.4 mPa	<b>2524 psi</b>	17.4 mPa	<b>2524 psi</b>
Maximum Drawbar Pull	15.8 kN	<b>3552 lb</b>	15.8 kN	<b>3552 lb</b>
	<b>Two Speed Travel</b>		<b>Two Speed Travel</b>	
Maximum Travel Speed at Rated RPM	Lo: 2.0 km/h Hi: 4.5 km/h	<b>1.2 mph</b> <b>2.8 mph</b>	Lo: 2.0 km/h Hi: 4.5 km/h	<b>1.2 mph</b> <b>2.8 mph</b>
Width of Standard Track Shoe	230 mm	<b>9"</b>	230 mm	<b>9"</b>
Overall Track Length	1575 mm	<b>62"</b>	1575 mm	<b>62"</b>
Ground Contact Area with Std. Shoe	0.61 m <sup>2</sup>	<b>950 in<sup>2</sup></b>	0.61 m <sup>2</sup>	<b>950 in<sup>2</sup></b>
Track Gauge:				
Standard Undercarriage	750 mm	<b>30"</b>	750 mm	<b>30"</b>
Variable Width Undercarriage		—	1110 mm	<b>44"</b>
Fuel Tank Refill Capacity	22 L	<b>5.8 U.S. gal</b>	22 L	<b>5.8 U.S. gal</b>
Hydraulic System (includes tank)	37 L	<b>9.8 U.S. gal</b>	37 L	<b>9.8 U.S. gal</b>

\*Operating weight includes coolant, lubricants, full fuel tank, cab, standard shoes, bucket, medium stick, and operator 75 kg (165 lb).

**NOTE:** Certain models may not be available in all Sales areas.

Specifications may also vary by Sales area.

Contact your Cat dealer for details.



MODEL	302.5C		303C CR		303.5C CR	
Sourcing	U.K.		Japan		Japan	
Flywheel Power	18.6 kW	24.9 hp	22 kW	29.5 hp	29 kW	38.9 hp
Operating Weight*	2850 kg		3555 kg		3910 kg	
with Additional Counterweight	6283 lb		7837 lb		8620 lb	
Bucket Capacity Range (heaped)	0.035-0.092 m <sup>3</sup>	0.046-0.12 yd <sup>3</sup>	0.049-0.159 m <sup>3</sup>	0.065-0.208 yd <sup>3</sup>	0.049-0.159 m <sup>3</sup>	0.065-0.208 yd <sup>3</sup>
Engine Model	Mitsubishi S3L2		Mitsubishi S3Q2		Mitsubishi S3Q2-T	
Rated Engine RPM	2300		2300		2400	
No. of Cylinders	3		3		3	
Bore	78 mm	3.07"	88 mm	3.46"	88 mm	3.46"
Stroke	92 mm	3.62"	103 mm	4.06"	103 mm	4.06"
Displacement	1318 cm <sup>3</sup>	80.4 in <sup>3</sup>	1900 cm <sup>3</sup>	115.9 in <sup>3</sup>	1900 cm <sup>3</sup>	115.9 in <sup>3</sup>
Max. Implement Hydraulic Pump Output at Rated RPM	2 × 32.9/ 1 × 19.5 L/min	2 × 8.7/ 1 × 5.2 gpm	1 × 87.6 L/min	1 × 23.1 gpm	1 × 87.6 L/min	1 × 23.1 gpm
Relief Valve Settings:						
Implement Circuits	22.1 mPa	3205 psi	24.5 mPa	3553 psi	24.5 mPa	3553 psi
Travel Circuits	22.1 mPa	3205 psi	24.5 mPa	3553 psi	24.5 mPa	3553 psi
Swing Circuits	17.4 mPa	2524 psi	17.2 mPa	2495 psi	18.1 mPa	2625 psi
Maximum Drawbar Pull	23.6 kN	5305 lb	33.4 kN	7509 lb	33.4 kN	7509 lb
	<b>Two Speed Travel</b>		<b>Two Speed Travel</b>		<b>Two Speed Travel</b>	
Maximum Travel Speed at Rated RPM	Lo: 2.5 km/h Hi: 5.0 km/h	1.6 mph 3.1 mph	Lo: 2.6 km/h Hi: 4.6 km/h	1.6 mph 2.9 mph	Lo: 2.6 km/h Hi: 4.6 km/h	1.6 mph 2.9 mph
Width of Standard Track Shoe	300 mm	12"	300 mm	12"	300 mm	12"
Overall Track Length	1925 mm	76"	2220 mm	87"	2220 mm	87"
Ground Contact Area with Std. Shoe	0.097 m <sup>2</sup>	1503 in <sup>2</sup>	1.19 m <sup>2</sup>	1845 in <sup>2</sup>	1.19 m <sup>2</sup>	1845 in <sup>2</sup>
Track Gauge:						
Standard Undercarriage	1150 mm	45"	1250 mm	49"	1480 mm	58"
Fuel Tank Refill Capacity	38 L	10.0 U.S. gal	45 L	11.9 U.S. gal	51 L	13.5 U.S. gal
Hydraulic System (includes tank)	50 L	13.2 U.S. gal	65 L	17.2 U.S. gal	65 L	17.2 U.S. gal

4

\*Operating weight for 302.5C and 303.5C CR includes coolant, lubricants, full fuel tank, cab, standard shoes, bucket, medium stick, and operator 75 kg (165 lb).

Operating weight for 303C CR includes coolant, lubricants, full fuel tank, canopy, rubber track, rubber shoes, bucket, medium stick, and operator 75 kg (165 lb).

**NOTE:** Certain models may not be available in all Sales areas.

Specifications may also vary by Sales area.

Contact your Cat dealer for details.



MODEL	304C CR		305C CR		305.5**	
Sourcing	Japan		Japan		China	
Flywheel Power	31 kW	<b>41.6 hp</b>	35 kW	<b>46.9 hp</b>	40.5 kW	<b>54.3 hp</b>
Operating Weight*	4920 kg		5320 kg		5480 kg	
with Additional Counterweight		<b>10,847 lb</b>		<b>11,729 lb</b>		<b>12,081 lb</b>
Bucket Capacity Range (heaped)	0.059-0.03 m <sup>3</sup>	<b>0.078-0.039 yd<sup>3</sup></b>	0.059-0.03 m <sup>3</sup>	<b>0.078-0.039 yd<sup>3</sup></b>	0.18 m <sup>3</sup>	<b>0.24 yd<sup>3</sup></b>
Engine Model	<b>Mitsubishi S4Q2</b>		<b>Mitsubishi S4Q2-T</b>		<b>4M40</b>	
Rated Engine RPM	<b>2400</b>		<b>2400</b>		<b>2100</b>	
No. of Cylinders	<b>4</b>		<b>4</b>		<b>4</b>	
Bore	88 mm	<b>3.46"</b>	88 mm	<b>3.46"</b>	95 mm	<b>3.7"</b>
Stroke	103 mm	<b>4.06"</b>	103 mm	<b>4.06"</b>	100 mm	<b>4.0"</b>
Displacement	2505 cm <sup>3</sup>		2505 cm <sup>3</sup>		2.84 L	
Max. Implement Hydraulic Pump Output at Rated RPM	1 × 119.3 L/min	<b>1 × 31.5 gpm</b>	1 × 129.6 L/min	<b>1 × 34.2 gpm</b>	152 L/min	<b>40.2 gpm</b>
Relief Valve Settings:						
Implement Circuits	24.5 mPa	<b>3553 psi</b>	24.5 mPa	<b>3553 psi</b>	24.5 mPa	<b>3550 psi</b>
Travel Circuits	24.5 mPa	<b>3553 psi</b>	24.5 mPa	<b>3553 psi</b>	24.5 mPa	<b>3550 psi</b>
Swing Circuits	17.6 mPa	<b>2553 psi</b>	18.4 mPa	<b>2669 psi</b>	19.6 mPa	<b>2840 psi</b>
Maximum Drawbar Pull	44.6 kN	<b>10,026 lb</b>	48.1 kN	<b>10,813 lb</b>	48.2 kN	<b>10,836 lb</b>
	<b>Two Speed Travel</b>		<b>Two Speed Travel</b>			
Maximum Travel Speed at Rated RPM	Lo: 2.6 km/h	<b>1.6 mph</b>	Lo: 2.6 km/h	<b>1.6 mph</b>	4.8 km/h	<b>3.0 mph</b>
	Hi: 4.6 km/h	<b>2.9 mph</b>	Hi: 4.6 km/h	<b>2.9 mph</b>		
Width of Standard Track Shoe	400 mm		400 mm		400 mm	
	<b>16"</b>		<b>16"</b>		<b>16"</b>	
Overall Track Length	2580 mm		2580 mm		2450 mm	
	<b>102"</b>		<b>102"</b>		<b>96.5"</b>	
Ground Contact Area with Std. Shoe	1.8 m <sup>2</sup>	<b>2796 in<sup>2</sup></b>	1.8 m <sup>2</sup>	<b>2796 in<sup>2</sup></b>	—	
Track Gauge:						
Standard Undercarriage	1580 mm	<b>62"</b>	1580 mm	<b>62"</b>	1550 mm	<b>61"</b>
Fuel Tank Refill Capacity	72 L	<b>19.0 U.S. gal</b>	72 L	<b>19.0 U.S. gal</b>	135 L	<b>35.7 U.S. gal</b>
Hydraulic System (includes tank)	78 L	<b>20.6 U.S. gal</b>	78 L	<b>20.6 U.S. gal</b>	85 L	<b>22.4 U.S. gal</b>

\*Operating weight for 304C CR includes coolant, lubricants, full fuel tank, cab, rubber track, rubber shoes, bucket, medium stick, and operator 75 kg (165 lb).

Operating weight for 305C CR and 305.5 includes coolant, lubricants, full fuel tank, cab, standard shoes, bucket, medium stick, and operator 75 kg (165 lb).

\*\*China and Korea only.

NOTE: Certain models may not be available in all Sales areas.

Specifications may also vary by Sales area.

Contact your Cat dealer for details.

**307C\*\*****307D****308D CR**

<b>MODEL</b>	<b>307C**</b>		<b>307D</b>		<b>308D CR</b>	
Sourcing	Japan		Japan		Japan	
Flywheel Power	41 kW	<b>54 hp</b>	41.5 kW	<b>55.6 hp</b>	41.5 kW	<b>55.6 hp</b>
Operating Weight*	7210 kg	<b>15,900 lb</b>	7075 kg	<b>15,598 lb</b>	7850 kg	<b>17,306 lb</b>
Bucket Capacity Range (heaped)	0.1-0.37 m <sup>3</sup>	<b>0.13-0.48 yd<sup>3</sup></b>	0.1-0.37 m <sup>3</sup>	<b>0.13-0.48 yd<sup>3</sup></b>	0.14-0.28 m <sup>3</sup>	<b>0.076-0.3 yd<sup>3</sup></b>
Engine Model	<b>4M40E1</b>		<b>4M40 TL</b>		<b>4M40 TL</b>	
Rated Engine RPM	<b>2100</b>		<b>2000</b>		<b>2000</b>	
No. of Cylinders	<b>4</b>		<b>4</b>		<b>4</b>	
Bore	95 mm	<b>3.7"</b>	95 mm	<b>3.7"</b>	95 mm	<b>3.7"</b>
Stroke	100 mm	<b>3.9"</b>	100 mm	<b>3.9"</b>	100 mm	<b>3.9"</b>
Displacement	2.84 L	<b>173 in<sup>3</sup></b>	2.84 L	<b>173 in<sup>3</sup></b>	2.835 L	<b>173 in<sup>3</sup></b>
Max. Implement Hydraulic Pump Output at Rated RPM	2 × 64 L/min	<b>2 × 17 gpm</b>	1 × 150 L/min	<b>1 × 39.6 gpm</b>	1 × 150 L/min	<b>1 × 39.6 gpm</b>
Relief Valve Settings:						
Implement Circuits	27 460 kPa	<b>3980 psi</b>	28 mPa	<b>4061 psi</b>	28 mPa	<b>4061 psi</b>
Travel Circuits	31 380 kPa	<b>4550 psi</b>	32 mPa	<b>4641 psi</b>	32 mPa	<b>4641 psi</b>
Swing Circuits	19 610 kPa	<b>2840 psi</b>	24 mPa	<b>3481 psi</b>	24 mPa	<b>3481 psi</b>
Pilot Circuits	4120 kPa	<b>600 psi</b>	4120 kPa	<b>600 psi</b>	4120 kPa	<b>600 psi</b>
Maximum Drawbar Pull	57 kN	<b>12,810 lb</b>	57 kN	<b>12,810 lb</b>	64.6 kN	<b>14,523 lb</b>
	<b>Two Speed Travel</b>		<b>Two Speed Travel</b>		<b>Two Speed Travel</b>	
Maximum Travel Speed at Rated RPM	Lo: 3.5 km/h	<b>2.2 mph</b>	Lo: 3.1 km/h	<b>1.9 mph</b>	Lo: 3.1 km/h	<b>1.9 mph</b>
	Hi: 5.3 km/h	<b>3.3 mph</b>	Hi: 5.0 km/h	<b>3.1 mph</b>	Hi: 5.0 km/h	<b>3.1 mph</b>
Width of Standard Track Shoe	600 mm	<b>24"</b>	450 mm	<b>18"</b>	450 mm	<b>18"</b>
Overall Track Length	2760 mm	<b>9'1"</b>	2760 mm	<b>9'1"</b>	2910 mm	<b>9'7"</b>
Ground Contact Area with Std. Shoe	2.81 m <sup>2</sup>	<b>4360 in<sup>2</sup></b>	2.81 m <sup>2</sup>	<b>4360 in<sup>2</sup></b>	3 m <sup>2</sup>	<b>4650 in<sup>2</sup></b>
Track Gauge:						
Standard Undercarriage	1750 mm	<b>5'9"</b>	1750 mm	<b>5'9"</b>	1870 mm	<b>6'2"</b>
Fuel Tank Refill Capacity	135 L	<b>36 U.S. gal</b>	135 L	<b>36 U.S. gal</b>	125 L	<b>33 U.S. gal</b>
Hydraulic System (includes tank)	94 L	<b>24.8 U.S. gal</b>	94 L	<b>24.8 U.S. gal</b>	92 L	<b>24.3 U.S. gal</b>

\*Operating weight for 307C and 307D includes coolant, lubricants, full fuel tank, cab, standard shoes, bucket, medium stick, and operator 75 kg (165 lb).

Operating weight for 308D CR includes coolant, lubricants, full fuel tank, canopy, rubber shoes, bucket, medium stick, and operator 75 kg (165 lb).

\*\*China only.

**NOTE:** Certain models may not be available in all Sales areas.

Specifications may also vary by Sales area.

Contact your Cat dealer for details.



MODEL	308D CR SB		311D LRR		312D		312D	
Sourcing	Japan		Japan		Japan		France	
Flywheel Power	41.5 kW	55.6 hp	60 kW	80 hp	67 kW	90 hp	67 kW	90 hp
Operating Weight*	8400 kg	18,519 lb	12 710 kg	28,021 lb	13 150 kg	29,000 lb	13 470 kg	29,700 lb
Bucket Capacity Range (heaped)	0.1-0.37 m <sup>3</sup>	0.13-0.48 yd <sup>3</sup>	0.25-0.74 m <sup>3</sup>	0.33-0.97 yd <sup>3</sup>	0.30-0.74 m <sup>3</sup>	0.39-0.97 yd <sup>3</sup>	0.21-0.72 m <sup>3</sup>	0.27-0.94 yd <sup>3</sup>
Engine Model	4M40 TL		C4.2 ACERT™		C4.2 ACERT		C4.2 ACERT	
Rated Engine RPM	2000		1700		1800		2200	
No. of Cylinders	4		4		4		4	
Bore	95 mm	4"	102 mm	4"	102 mm	4"	102 mm	4"
Stroke	100 mm	4"	130 mm	5.1"	130 mm	5.1"	130 mm	5.1"
Displacement	2.84 L	173 in <sup>3</sup>	4.25 L	259 in <sup>3</sup>	4.25 L	259 in <sup>3</sup>	4.25 L	259 in <sup>3</sup>
Max. Implement Hydraulic Pump Output at Rated RPM	1 × 150 L/min	1 × 39.6 gpm	2 × 117 L/min	2 × 30.9 gpm	2 × 127 L/min	2 × 33.5 gpm	2 × 127 L/min	2 × 33.5 gpm
Relief Valve Settings:								
Implement Circuits	28 mPa	4061 psi	30 500 kPa	4424 psi	30 500 kPa	4424 psi	30 500 kPa	4424 psi
Travel Circuits	32 mPa	4641 psi	35 000 kPa	5076 psi	35 000 kPa	5076 psi	35 000 kPa	5076 psi
Swing Circuits	24 mPa	3481 psi	23 000 kPa	3336 psi	23 000 kPa	3336 psi	23 000 kPa	3336 psi
Pilot Circuits	4120 kPa	600 psi	4120 kPa	600 psi	4120 kPa	600 psi	3600 kPa	522 psi
Maximum Drawbar Pull	64 kN	14,388 lb	114 kN	25,600 lb	114 kN	25,600 lb	114 kN	25,650 lb
Maximum Travel Speed at Rated RPM	<b>Two Speed Travel</b> Lo: 3.1 km/h Hi: 5.0 km/h		<b>Two Speed Travel</b> Lo: 3.5 km/h Hi: 5.1 km/h		<b>Two Speed Travel</b> Lo: 3.8 km/h Hi: 5.5 km/h		<b>Two Speed Travel</b> Lo: 3.9 km/h Hi: 5.5 km/h	
Width of Standard Track Shoe	450 mm	18"	500 mm	20"	600 mm	24"	500 mm	20"
Overall Track Length	2760 mm	9'1"	3490 mm	11'5"	3490 mm	11'5"	3490 mm	11'5"
Ground Contact Area with Std. Shoe	2.81 m <sup>2</sup>	4360 in <sup>2</sup>	2.8 m <sup>2</sup>	4360 in <sup>2</sup>	3.3 m <sup>2</sup>	5232 in <sup>2</sup>	3.03 m <sup>2</sup>	4700 in <sup>2</sup>
Track Gauge: Standard Undercarriage	1750 mm	5'9"	1990 mm	6'6"	1990 mm	6'6"	1990 mm	6'6"
Fuel Tank Refill Capacity	125 L	33 U.S. gal	210 L	55 U.S. gal	250 L	66 U.S. gal	250 L	66 U.S. gal
Hydraulic System (includes tank)	94 L	24.8 U.S. gal	145 L	38 U.S. gal	162 L	42.8 U.S. gal	162 L	42.8 U.S. gal

\*Operating weight includes coolant, lubricants, full fuel tank, cab, standard shoes, bucket, medium stick, and operator 75 kg (165 lb).

**NOTE:** Certain models may not be available in all Sales areas.

Specifications may also vary by Sales area.

Contact your Cat dealer for details.



MODEL	312D L		312D L		313C SR		313C CR	
Sourcing	Japan		France		Japan		Japan	
Flywheel Power	67 kW	<b>90 hp</b>	67 kW	<b>90 hp</b>	59 kW	<b>79 hp</b>	59 kW	<b>79 hp</b>
Operating Weight*	13 450 kg	<b>29,650 lb</b>	13 470 kg	<b>29,700 lb</b>	14 000 kg	<b>30,860 lb</b>	13 400 kg	<b>29,540 lb</b>
Bucket Capacity	0.30-0.74 m <sup>3</sup> <b>0.39-0.97 yd<sup>3</sup></b>		0.21-0.72 m <sup>3</sup> <b>0.27-0.94 yd<sup>3</sup></b>		0.32-0.45 m <sup>3</sup> <b>0.42-0.59 yd<sup>3</sup></b>		0.32-0.5 m <sup>3</sup> <b>0.42-0.75 yd<sup>3</sup></b>	
Engine Model	<b>C4.2 ACERT</b>		<b>C4.2 ACERT</b>		<b>3064 T</b>		<b>3064 T</b>	
Rated Engine RPM	<b>1800</b>		<b>2200</b>		<b>1800</b>		<b>1800</b>	
No. of Cylinders	<b>4</b>		<b>4</b>		<b>4</b>		<b>4</b>	
Bore	102 mm	<b>4"</b>	102 mm	<b>4"</b>	102 mm	<b>4"</b>	102 mm	<b>4"</b>
Stroke	130 mm	<b>5.1"</b>	130 mm	<b>5"</b>	130 mm	<b>5"</b>	130 mm	<b>5"</b>
Displacement	4.25 L	<b>259 in<sup>3</sup></b>	4.25 L	<b>259 in<sup>3</sup></b>	4.25 L	<b>259 in<sup>3</sup></b>	4.25 L	<b>259 in<sup>3</sup></b>
Max. Implement Hydraulic Pump Output at Rated RPM	2 × 127 L/min	<b>2 × 33.5 gpm</b>	2 × 127 L/min	<b>2 × 33.5 gpm</b>	2 × 117 L/min	<b>2 × 30.9 gpm</b>	2 × 117 L/min	<b>2 × 30.9 gpm</b>
Relief Valve Settings:								
Implement Circuits	30 500 kPa	<b>4424 psi</b>	30 500 kPa	<b>4422.5 psi</b>	29 900 kPa	<b>4340 psi</b>	29 900 kPa	<b>4340 psi</b>
Travel Circuits	35 000 kPa	<b>5076 psi</b>	35 000 kPa	<b>5075 psi</b>	34 300 kPa	<b>4970 psi</b>	34 300 kPa	<b>4970 psi</b>
Swing Circuits	23 000 kPa	<b>3336 psi</b>	23 000 kPa	<b>3335 psi</b>	24 500 kPa	<b>3550 psi</b>	24 500 kPa	<b>3550 psi</b>
Pilot Circuits	4120 kPa	<b>600 psi</b>	3600 kPa	<b>522 psi</b>	4100 kPa	<b>590 psi</b>	4100 kPa	<b>590 psi</b>
Maximum Drawbar Pull	114 kN	<b>25,600 lb</b>	114 kN	<b>25,650 lb</b>	110 kN	<b>24,720 lb</b>	110 kN	<b>24,720 lb</b>
Maximum Travel Speed at Rated RPM	<b>Two Speed Travel</b> Lo: 3.8 km/h <b>2.3 mph</b> Hi: 5.5 km/h <b>3.4 mph</b>		<b>Two Speed Travel</b> Lo: 3.9 km/h <b>2.4 mph</b> Hi: 5.5 km/h <b>3.4 mph</b>		<b>Two Speed Travel</b> Lo: 3.6 km/h <b>2.2 mph</b> Hi: 5.2 km/h <b>3.2 mph</b>		<b>Two Speed Travel</b> Lo: 3.6 km/h <b>2.2 mph</b> Hi: 5.2 km/h <b>3.2 mph</b>	
Width of Standard Track Shoe	600 mm	<b>24"</b>	500 mm	<b>20"</b>	500 mm	<b>20"</b>	500 mm	<b>20"</b>
Overall Track Length	3750 mm	<b>12'4"</b>	3490 mm	<b>11'5"</b>	2780 mm	<b>9'1"</b>	2780 mm	<b>9'1"</b>
Ground Contact Area with Std. Shoe	3.6 m <sup>2</sup>	<b>5760 in<sup>2</sup></b>	3.03 m <sup>2</sup>	<b>4700 in<sup>2</sup></b>	3.03 m <sup>2</sup>	<b>4700 in<sup>2</sup></b>	3.03 m <sup>2</sup>	<b>4700 in<sup>2</sup></b>
Track Gauge	1990 mm	<b>6'6"</b>	1990 mm	<b>6'6"</b>	1990 mm	<b>6'6"</b>	1990 mm	<b>6'6"</b>
Fuel Tank Refill Capacity	250 L	<b>66 U.S. gal</b>	250 L	<b>66 U.S. gal</b>	200 L	<b>53 U.S. gal</b>	200 L	<b>53 U.S. gal</b>
Hydraulic System (includes tank)	162 L	<b>42.8 U.S. gal</b>	162 L	<b>42.8 U.S. gal</b>	150 L	<b>39.6 U.S. gal</b>	150 L	<b>39.6 U.S. gal</b>

\*Operating weight for 312D L includes coolant, lubricants, full fuel tank, standard shoes, bucket, medium stick, and operator 75 kg (165 lb).

Operating weight for 313C SR and 313C CR includes coolant, lubricants, full fuel tank, standard shoes, bucket, blade, medium stick, and operator 75 kg (165 lb).

**NOTE:** Certain models may not be available in all Sales areas.

Specifications may also vary by Sales area.

Contact your Cat dealer for details.



MODEL	314D CR		314D LCR		315D L	
Sourcing	Japan		Japan		Japan, France	
Flywheel Power	67 kW	<b>90 hp</b>	67 kW	<b>90 hp</b>	86 kW	<b>115 hp</b>
Operating Weight*	14 200 kg	<b>31,306 lb</b>	14 400 kg	<b>31,747 lb</b>	17 280 kg	<b>38,100 lb</b>
Bucket Capacity Range (heaped)	0.25-0.74 m <sup>3</sup>	<b>0.33-0.97 yd<sup>3</sup></b>	0.25-0.74 m <sup>3</sup>	<b>0.33-0.97 yd<sup>3</sup></b>	0.33-0.86 m <sup>3</sup>	<b>0.43-1.13 yd<sup>3</sup></b>
Engine Model	<b>C4.2 ACERT</b>		<b>C4.2 ACERT</b>		<b>C4.2</b>	
Rated Engine RPM	<b>1800</b>		<b>1800</b>		<b>2150</b>	
No. of Cylinders	<b>4</b>		<b>4</b>		<b>4</b>	
Bore	102 mm	<b>4"</b>	102 mm	<b>4"</b>	102 mm	<b>4"</b>
Stroke	130 mm	<b>5.1"</b>	130 mm	<b>5.1"</b>	130 mm	<b>5.1"</b>
Displacement	4.25 L	<b>259 in<sup>3</sup></b>	4.25 L	<b>259 in<sup>3</sup></b>	4.25 L	<b>259 in<sup>3</sup></b>
Max. Implement Hydraulic Pump Output at Rated RPM	2 × 127 L/min	<b>2 × 33.5 gpm</b>	2 × 127 L/min	<b>2 × 33.5 gpm</b>	2 × 150 L/min	<b>2 × 39.6 gpm</b>
Relief Valve Settings:						
Implement Circuits	30 500 kPa	<b>4424 psi</b>	30 500 kPa	<b>4424 psi</b>	35 000 kPa	<b>5080 psi</b>
Travel Circuits	35 000 kPa	<b>5076 psi</b>	35 000 kPa	<b>5076 psi</b>	35 000 kPa	<b>5080 psi</b>
Swing Circuits	23 000 kPa	<b>3336 psi</b>	23 000 kPa	<b>3336 psi</b>	22 550 kPa	<b>3270 psi</b>
Pilot Circuits	4120 kPa	<b>600 psi</b>	4120 kPa	<b>600 psi</b>	4120 kPa	<b>600 psi</b>
Maximum Drawbar Pull	114 kN	<b>25,600 lb</b>	113 kN	<b>25,402 lb</b>	157 kN	<b>35,300 lb</b>
	<b>Two Speed Travel</b>		<b>Two Speed Travel</b>		<b>Two Speed Travel</b>	
Maximum Travel Speed at Rated RPM	Lo: 3.8 km/h	<b>2.3 mph</b>	Lo: 3.8 km/h	<b>2.3 mph</b>	Lo: 3.5 km/h	<b>2.2 mph</b>
	Hi: 5.5 km/h	<b>3.4 mph</b>	Hi: 5.5 km/h	<b>3.4 mph</b>	Hi: 5.6 km/h	<b>3.5 mph</b>
Width of Standard Track Shoe	500 mm	<b>20"</b>	500 mm	<b>20"</b>	600 mm	<b>24"</b>
Overall Track Length	3490 mm	<b>11'5"</b>	3750 mm	<b>12'4"</b>	3970 mm	<b>13'0"</b>
Ground Contact Area with Std. Shoe	2.8 m <sup>2</sup>	<b>4360 in<sup>2</sup></b>	3.0 m <sup>2</sup>	<b>4800 in<sup>2</sup></b>	3.8 m <sup>2</sup>	<b>6000 in<sup>2</sup></b>
Track Gauge	1990 mm	<b>6'6"</b>	1990 mm	<b>6'6"</b>	1990 mm	<b>6'6"</b>
Fuel Tank Refill Capacity	186 L	<b>49 U.S. gal</b>	186 L	<b>49 U.S. gal</b>	300 L	<b>79.3 U.S. gal</b>
Hydraulic System (includes tank)	160 L	<b>42 U.S. gal</b>	160 L	<b>42 U.S. gal</b>	190 L	<b>50.2 U.S. gal</b>

\*Operating weight for 314D CR and 314D LCR includes coolant, lubricants, full fuel tank, standard shoes, bucket, blade, medium stick, and operator 75 kg (165 lb). Operating weight for 315D L includes coolant, lubricants, full fuel tank, standard shoes, bucket, medium stick, and operator 75 kg (165 lb).

**NOTE:** Certain models may not be available in all Sales areas.

Specifications may also vary by Sales area.  
Contact your Cat dealer for details.



MODEL	319D L		319D LN	
Sourcing	France		France	
Flywheel Power	93 kW	124.7 hp	93 kW	124.7 hp
Operating Weight*	19 500 kg	43,005 lb	19 500 kg	43,005 lb
Bucket Capacity Range (heaped)	0.38-1.13 m <sup>3</sup>	0.5-1.48 yd <sup>3</sup>	0.38-1.13 m <sup>3</sup>	0.5-1.48 yd <sup>3</sup>
Engine Model	C4.2 ACERT		C4.2 ACERT	
Rated Engine RPM	2200		2200	
No. of Cylinders	4		4	
Bore	102 mm	4"	102 mm	4"
Stroke	130 mm	5"	130 mm	5"
Displacement	4.249 L	259.3 in <sup>3</sup>	4.249 L	259.3 in <sup>3</sup>
Max. Implement Hydraulic Pump Output at Rated RPM	2 × 176 L/min	2 × 46 gpm	2 × 176 L/min	2 × 46 gpm
Relief Valve Settings:				
Implement Circuits	35 000 kPa	5076 psi	35 000 kPa	5076 psi
Travel Circuits	36 300 kPa	5265 psi	36 300 kPa	5265 psi
Swing Circuits	23 000 kPa	3336 psi	23 000 kPa	3336 psi
Pilot Circuits	4120 kPa	598 psi	4120 kPa	598 psi
Maximum Drawbar Pull	207 kN	46,535 lb	207 kN	46,535 lb
	Two Speed Travel		Two Speed Travel	
Maximum Travel Speed at Rated RPM	Lo: 3.0 km/h	1.86 mph	Lo: 3.0 km/h	1.86 mph
	Hi: 5.0 km/h	3.1 mph	Hi: 5.0 km/h	3.1 mph
Width of Standard Track Shoe	600 mm	24"	500 mm	20"
Overall Track Length	4450 mm	13'3"	4450 mm	13'3"
Ground Contact Area with Std. Shoe	4.3 m <sup>2</sup>	6665 in <sup>2</sup>	3.6 m <sup>2</sup>	5580 in <sup>2</sup>
Track Gauge	2200 mm	7'3"	1995 mm	6'7"
Fuel Tank Refill Capacity	300 L	79 U.S. gal	300 L	79 U.S. gal
Hydraulic System (includes tank)	190 L	50 U.S. gal	190 L	50 U.S. gal

\*Operating weight for 319D L and 319D LN includes coolant, lubricants, full fuel tank, standard shoes, bucket, medium stick, and operator 75 kg (165 lb).

NOTE: Certain models may not be available in all Sales areas.

Specifications may also vary by Sales area.

Contact your Cat dealer for details.





MODEL	M313D		M315D		M316D	
Flywheel Power	95 kW	<b>129 hp</b>	101 kW	<b>137 hp</b>	118 kW	<b>160 hp</b>
Operating Weight*	14 000- 16 200 kg	<b>30,870- 35,721 lb</b>	16 100- 18 300 kg	<b>35,501- 40,352 lb</b>	17 600- 19 800 kg	<b>38,808- 43,659 lb</b>
Bucket Capacity Range (heaped)	0.18-0.92 m <sup>3</sup>	<b>0.24-1.2 yd<sup>3</sup></b>	0.38-1.26 m <sup>3</sup>	<b>0.5-1.65 yd<sup>3</sup></b>	0.38-1.26 m <sup>3</sup>	<b>0.5-1.65 yd<sup>3</sup></b>
Engine Model	<b>C4.4 ACERT</b>		<b>C4.4 ACERT</b>		<b>C6.6 ACERT</b>	
Rated Engine RPM	<b>2000</b>		<b>2000</b>		<b>1800</b>	
No. of Cylinders	<b>4</b>		<b>4</b>		<b>6</b>	
Bore	105 mm	<b>4.1"</b>	105 mm	<b>4.1"</b>	105 mm	<b>4.1"</b>
Stroke	127 mm	<b>5"</b>	127 mm	<b>5"</b>	127 mm	<b>5"</b>
Displacement	4.4 L	<b>269 in<sup>3</sup></b>	4.4 L	<b>269 in<sup>3</sup></b>	6.6 L	<b>403 in<sup>3</sup></b>
Max. Implement Hydraulic Pump Output at Rated RPM	190+80 L/min	<b>50+21 gpm</b>	220+80 L/min	<b>58+21 gpm</b>	250+80 L/min	<b>66+21 gpm</b>
Tires — standard	<b>10.00-20 dual pneumatic</b>		<b>10.00-20 dual pneumatic</b>		<b>10.00-20 dual pneumatic</b>	
— optional	<b>11.00-20 dual pneumatic</b>		<b>10.00-20 dual solid rubber</b>		<b>10.00-20 dual solid rubber</b>	
	<b>18-R 19.5 XF single</b>		<b>18-R 19.5 XF single</b>		<b>18-R 19.5 XF single</b>	
	<b>600/40-22.5 single</b>		<b>600/40-22.5 single</b>		<b>600/40-22.5 single</b>	
			<b>11.00-20 dual pneumatic</b>		<b>11.00-20 dual pneumatic</b>	
Maximum Travel Speed	37 km/h	<b>23 mph</b>	34 km/h	<b>21 mph</b>	37 km/h	<b>23 mph</b>
Wheel Base	2500 mm	<b>8'2"</b>	2550 mm	<b>8'4"</b>	2600 mm	<b>8'6"</b>
Width Over Tires**	2550 mm	<b>8'4"</b>	2550 mm	<b>8'4"</b>	2550 mm	<b>8'4"</b>
Ground Clearance**	370 mm	<b>14.7"</b>	370 mm	<b>14.7"</b>	370 mm	<b>14.7"</b>
Fuel Tank Refill Capacity	235 L	<b>62 U.S. gal</b>	235 L	<b>62 U.S. gal</b>	310 L	<b>61 U.S. gal</b>
Hydraulic System (includes tank)	180 L	<b>48 U.S. gal</b>	220 L	<b>58 U.S. gal</b>	220 L	<b>58 U.S. gal</b>

\*Operating weight includes full fuel tank, operator 75 kg (165 lb), one-piece boom, mid-size stick and bucket, and two sets of outriggers.

\*\*With standard tires.

**NOTE:** Standard cold inflation pressure for all tires is 650 kPa (94 psi).

Certain models may not be available in all Sales areas.

Specifications may also vary by Sales area.

Contact your Cat dealer for details.

**M318D****M322D**

<b>MODEL</b>	<b>M318D</b>		<b>M322D</b>	
Flywheel Power	124 kW	<b>169 hp</b>	123 kW	<b>167 hp</b>
Operating Weight*	18 200-20 100 kg	<b>40,124-44,312 lb</b>	20 500-22 500 kg	<b>45,195-49,604 lb</b>
Bucket Capacity Range (heaped)	0.38-1.26 m <sup>3</sup>	<b>0.5-1.65 yd<sup>3</sup></b>	0.44-1.57 m <sup>3</sup>	<b>0.58-2.05 yd<sup>3</sup></b>
Engine Model	<b>C6.6 ACERT</b>		<b>C6.6 ACERT</b>	
Rated Engine RPM	<b>1800</b>		<b>2000</b>	
No. of Cylinders	<b>6</b>		<b>6</b>	
Bore	105 mm	<b>4.1"</b>	105 mm	<b>4.1"</b>
Stroke	127 mm	<b>5"</b>	127 mm	<b>5"</b>
Displacement	6.6 L	<b>403 in<sup>3</sup></b>	6.6 L	<b>403 in<sup>3</sup></b>
Max. Implement Hydraulic Pump Output at Rated RPM	290+112 L/min	<b>76+29 gpm</b>	350+112 L/min	<b>92+28 gpm</b>
Tires — standard	<b>10.00-20 dual pneumatic</b>		<b>11.00-20 dual pneumatic</b>	
— optional	<b>10.00-20 dual solid rubber</b>		<b>11.00-20 dual solid rubber</b>	
	<b>18-R 19.5 XF single</b>		<b>18-R 19.5 XF single</b>	
	<b>600/40-22.5 single</b>		<b>600/40-22.5 single</b>	
	<b>11.00-20 dual pneumatic</b>			
Maximum Travel Speed	37 km/h	<b>23 mph</b>	25 km/h	<b>15 mph</b>
Wheel Base	2600 mm	<b>8'6"</b>	2750 mm	<b>9'0"</b>
Width Over Tires**	2550 mm	<b>8'4"</b>	2750 mm	<b>9'0"</b>
Ground Clearance**	370 mm	<b>1'3"</b>	380 mm	<b>1'3"</b>
Fuel Tank Refill Capacity	385 L	<b>102 U.S. gal</b>	385 L	<b>102 U.S. gal</b>
Hydraulic System (includes tank)	270 L	<b>71 U.S. gal</b>	335 L	<b>89 U.S. gal</b>

\*Operating weight includes full fuel tank, operator 75 kg (165 lb), one-piece boom, mid-size stick and bucket, and two sets of outriggers.

\*\*With standard tires.

**NOTE:** Standard cold inflation pressure for all tires is 650 kPa (94 psi).

Certain models may not be available in all Sales areas.

Specifications may also vary by Sales area.

Contact your Cat dealer for details.



MODEL	320D		320D		320D RR		320D L	
Sourcing	Japan, China, Indonesia, Brazil		Japan		Japan		Japan, China, Indonesia, Brazil	
Flywheel Power	103 kW	<b>138 hp</b>	110 kW	<b>148 hp</b>	103 kW	<b>138 hp</b>	103 kW	<b>138 hp</b>
Operating Weight*	20 300 kg	<b>44,700 lb</b>	20 300 kg	<b>44,700 lb</b>	22 800 kg	<b>50,265 lb</b>	21 500 kg	<b>47,400 lb</b>
Bucket Capacity Range (heaped)	0.45-1.5 m <sup>3</sup>	<b>0.59-1.96 yd<sup>3</sup></b>	0.45-1.5 m <sup>3</sup>	<b>0.59-1.96 yd<sup>3</sup></b>	0.8-1.5 m <sup>3</sup>	<b>1.05-1.96 yd<sup>3</sup></b>	0.45-1.7 m <sup>3</sup>	<b>0.59-2.2 yd<sup>3</sup></b>
Engine Model	<b>C6.4 ACERT</b>		<b>C6.4 ACERT</b>		<b>C6.4 ACERT</b>		<b>C6.4 ACERT</b>	
Rated Engine RPM	<b>1800</b>		<b>1800</b>		<b>1800</b>		<b>1800</b>	
No. of Cylinders	<b>6</b>		<b>6</b>		<b>6</b>		<b>6</b>	
Bore	102 mm	<b>4"</b>	102 mm	<b>4"</b>	102 mm	<b>4"</b>	102 mm	<b>4"</b>
Stroke	130 mm	<b>5"</b>	130 mm	<b>5"</b>	130 mm	<b>5"</b>	130 mm	<b>5"</b>
Displacement	6.4 L	<b>391 in<sup>3</sup></b>	6.4 L	<b>391 in<sup>3</sup></b>	6.4 L	<b>391 in<sup>3</sup></b>	6.4 L	<b>391 in<sup>3</sup></b>
Max. Implement Hydraulic Pump Output at Rated RPM	2 × 205 L/min	<b>2 × 54 gpm</b>	2 × 205 L/min	<b>2 × 54 gpm</b>	2 × 205 L/min	<b>2 × 54 gpm</b>	2 × 205 L/min	<b>2 × 54 gpm</b>
Relief Valve Settings:								
Implement Circuits	35 000 kPa	<b>5076 psi</b>	35 000 kPa	<b>5076 psi</b>	35 000 kPa	<b>5076 psi</b>	35 000 kPa	<b>5076 psi</b>
Travel Circuits	35 000 kPa	<b>5076 psi</b>	35 000 kPa	<b>5076 psi</b>	35 000 kPa	<b>5076 psi</b>	35 000 kPa	<b>5076 psi</b>
Swing Circuits	25 000 kPa	<b>3630 psi</b>	25 000 kPa	<b>3630 psi</b>	25 000 kPa	<b>3630 psi</b>	25 000 kPa	<b>3630 psi</b>
Pilot Circuits	3900 kPa	<b>566 psi</b>	3900 kPa	<b>566 psi</b>	3900 kPa	<b>566 psi</b>	3900 kPa	<b>566 psi</b>
Maximum Drawbar Pull	206 kN	<b>46,311 lb</b>	206 kN	<b>46,311 lb</b>	206 kN	<b>46,311 lb</b>	206 kN	<b>46,311 lb</b>
Maximum Travel Speed at Rated RPM	<b>Two Speed Travel</b> Lo: 3.5 km/h <b>2.2 mph</b> Hi: 5.5 km/h <b>3.4 mph</b>		<b>Two Speed Travel</b> Lo: 3.5 km/h <b>2.2 mph</b> Hi: 5.5 km/h <b>3.4 mph</b>		<b>Two Speed Travel</b> Lo: 3.5 km/h <b>2.2 mph</b> Hi: 5.5 km/h <b>3.4 mph</b>		<b>Two Speed Travel</b> Lo: 3.5 km/h <b>2.2 mph</b> Hi: 5.5 km/h <b>3.4 mph</b>	
Width of Standard Track Shoe	600 mm	<b>2'0"</b>	600 mm	<b>2'0"</b>	600 mm	<b>2'0"</b>	800 mm	<b>2'8"</b>
Overall Track Length	4075 mm	<b>13'4"</b>	4075 mm	<b>13'4"</b>	4075 mm	<b>13'4"</b>	4450 mm	<b>14'7"</b>
Ground Contact Area with Std. Shoe	4.26 m <sup>2</sup>	<b>6600 in<sup>2</sup></b>	4.26 m <sup>2</sup>	<b>6600 in<sup>2</sup></b>	4.26 m <sup>2</sup>	<b>6600 in<sup>2</sup></b>	4.72 m <sup>2</sup>	<b>7320 in<sup>2</sup></b>
Track Gauge	2200 mm	<b>7'3"</b>	2200 mm	<b>7'3"</b>	2200 mm	<b>7'3"</b>	2380 mm	<b>7'10"</b>
Fuel Tank Refill Capacity	410 L	<b>108 U.S. gal</b>	410 L	<b>108 U.S. gal</b>	284 L	<b>75 U.S. gal</b>	410 L	<b>108 U.S. gal</b>
Hydraulic System (includes tank)	260 L	<b>69 U.S. gal</b>	260 L	<b>69 U.S. gal</b>	240 L	<b>63 U.S. gal</b>	260 L	<b>69 U.S. gal</b>

\*Operating weight includes coolant, lubricants, full fuel tank, standard shoes, bucket and operator 75 kg (165 lb).

**NOTE:** Certain models may not be available in all Sales areas.

Specifications may also vary by Sales area.

Contact your Cat dealer for details.



MODEL	320D L		320D LRR		320D LRR		321D LCR	
Sourcing	Japan		Japan		Japan		Japan	
Flywheel Power	110 kW	<b>148 hp</b>	103 kW	<b>138 hp</b>	110 kW	<b>148 hp</b>	103 kW	<b>138 hp</b>
Operating Weight*	21 570 kg	<b>47,400 lb</b>	24 000 kg	<b>52,911 lb</b>	24 000 kg	<b>52,911 lb</b>	24 180 kg	<b>53,308 lb</b>
Bucket Capacity	0.45-1.7 m <sup>3</sup> <b>0.59-2.2 yd<sup>3</sup></b>		0.8-1.5 m <sup>3</sup> <b>1.05-1.96 yd<sup>3</sup></b>		0.8-1.7 m <sup>3</sup> <b>1.05-2.2 yd<sup>3</sup></b>		0.8-1.7 m <sup>3</sup> <b>1.05-2.2 yd<sup>3</sup></b>	
Engine Model	<b>C6.4 ACERT</b>		<b>C6.4 ACERT</b>		<b>C6.4 ACERT</b>		<b>C6.4 ACERT</b>	
Rated Engine RPM	<b>1800</b>		<b>1800</b>		<b>1800</b>		<b>1800</b>	
No. of Cylinders	<b>6</b>		<b>6</b>		<b>6</b>		<b>6</b>	
Bore	102 mm	<b>4"</b>	102 mm	<b>4"</b>	102 mm	<b>4"</b>	102 mm	<b>4"</b>
Stroke	130 mm	<b>5"</b>	130 mm	<b>5"</b>	130 mm	<b>5"</b>	130 mm	<b>5"</b>
Displacement	6.4 L	<b>391 in<sup>3</sup></b>	6.4 L	<b>391 in<sup>3</sup></b>	6.4 L	<b>391 in<sup>3</sup></b>	6.4 L	<b>391 in<sup>3</sup></b>
Max. Implement Hydraulic Pump Output at Rated RPM	2 × 205 L/min	<b>2 × 54 gpm</b>	2 × 205 L/min	<b>2 × 54 gpm</b>	2 × 205 L/min	<b>2 × 54 gpm</b>	2 × 205 L/min	<b>2 × 54 gpm</b>
Relief Valve Settings:	Implement Circuits 35 000 kPa <b>5076 psi</b>		Implement Circuits 35 000 kPa <b>5076 psi</b>		Implement Circuits 35 000 kPa <b>5076 psi</b>		Implement Circuits 35 000 kPa <b>5076 psi</b>	
	Travel Circuits 35 000 kPa <b>5076 psi</b>		Travel Circuits 35 000 kPa <b>5076 psi</b>		Travel Circuits 35 000 kPa <b>5076 psi</b>		Travel Circuits 35 000 kPa <b>5076 psi</b>	
	Swing Circuits 25 000 kPa <b>3630 psi</b>		Swing Circuits 25 000 kPa <b>3630 psi</b>		Swing Circuits 25 000 kPa <b>3630 psi</b>		Swing Circuits 25 000 kPa <b>3630 psi</b>	
	Pilot Circuits 3900 kPa <b>566 psi</b>		Pilot Circuits 3900 kPa <b>566 psi</b>		Pilot Circuits 3900 kPa <b>566 psi</b>		Pilot Circuits 3900 kPa <b>566 psi</b>	
Maximum Drawbar Pull	206 kN	<b>46,311 lb</b>	206 kN	<b>46,311 lb</b>	206 kN	<b>46,311 lb</b>	206 kN	<b>46,311 lb</b>
Maximum Travel Speed at Rated RPM	<b>Two Speed Travel</b> Lo: 3.5 km/h <b>2.2 mph</b> Hi: 5.5 km/h <b>3.4 mph</b>		<b>Two Speed Travel</b> Lo: 3.5 km/h <b>2.2 mph</b> Hi: 5.5 km/h <b>3.4 mph</b>		<b>Two Speed Travel</b> Lo: 3.5 km/h <b>2.2 mph</b> Hi: 5.5 km/h <b>3.4 mph</b>		<b>Two Speed Travel</b> Lo: 3.5 km/h <b>2.2 mph</b> Hi: 5.5 km/h <b>3.4 mph</b>	
Width of Standard Track Shoe	800 mm	<b>2'8"</b>	800 mm	<b>2'8"</b>	800 mm	<b>2'8"</b>	800 mm	<b>2'8"</b>
Overall Track Length	4450 mm	<b>14'7"</b>	4450 mm	<b>14'7"</b>	4450 mm	<b>14'7"</b>	4450 mm	<b>14'7"</b>
Ground Contact Area with Std. Shoe	4.72 m <sup>2</sup>	<b>7320 in<sup>2</sup></b>	4.72 m <sup>2</sup>	<b>7320 in<sup>2</sup></b>	4.72 m <sup>2</sup>	<b>7320 in<sup>2</sup></b>	4.72 m <sup>2</sup>	<b>7320 in<sup>2</sup></b>
Track Gauge	2380 mm	<b>7'10"</b>	2380 mm	<b>7'10"</b>	2380 mm	<b>7'10"</b>	2380 mm	<b>7'10"</b>
Fuel Tank Refill Capacity	410 L	<b>108 U.S. gal</b>	284 L	<b>75 U.S. gal</b>	284 L	<b>75 U.S. gal</b>	330 L	<b>87 U.S. gal</b>
Hydraulic System (includes tank)	260 L	<b>69 U.S. gal</b>	240 L	<b>63 U.S. gal</b>	240 L	<b>63 U.S. gal</b>	208 L	<b>55 U.S. gal</b>

\*Operating weight includes coolant, lubricants, full fuel tank, standard shoes, bucket and operator 75 kg (165 lb).

NOTE: Certain models may not be available in all Sales areas.

Specifications may also vary by Sales area.  
Contact your Cat dealer for details.



MODEL	321D LCR		323D L		323D L		323D LN	
Sourcing	Japan		Belgium, Brazil, Japan		China		France	
Flywheel Power	110 kW	<b>148 hp</b>	110 kW	<b>147 hp</b>	110 kW	<b>147 hp</b>	110 kW	<b>147 hp</b>
Operating Weight*	24 180 kg	<b>53,308 lb</b>	23 190 kg	<b>51,134 lb</b>	22 300-23 100 kg	<b>49,172-50,936 lb</b>	23 000 kg	<b>50,715 lb</b>
Bucket Capacity Range (heaped)	0.8-1.7 m <sup>3</sup>	<b>1.05-2.2 yd<sup>3</sup></b>	0.47-1.38 m <sup>3</sup>	<b>0.61-1.8 yd<sup>3</sup></b>	0.47-1.38 m <sup>3</sup>	<b>0.61-1.8 yd<sup>3</sup></b>	0.41-1.7 m <sup>3</sup>	<b>0.54-2.2 yd<sup>3</sup></b>
Engine Model	<b>C6.4 ACERT</b>		<b>C6.4 ACERT</b>		<b>C6.4 ACERT</b>		<b>C6.4 ACERT</b>	
Rated Engine RPM	<b>1800</b>		<b>1800</b>		<b>1800</b>		<b>1800</b>	
No. of Cylinders	<b>6</b>		<b>6</b>		<b>6</b>		<b>6</b>	
Bore	102 mm	<b>4"</b>	102 mm	<b>4"</b>	102 mm	<b>4"</b>	102 mm	<b>4"</b>
Stroke	130 mm	<b>5"</b>	130 mm	<b>5"</b>	130 mm	<b>5"</b>	130 mm	<b>5"</b>
Displacement	6.4 L	<b>391 in<sup>3</sup></b>	6.4 L	<b>391 in<sup>3</sup></b>	6.4 L	<b>391 in<sup>3</sup></b>	6.4 L	<b>391 in<sup>3</sup></b>
Max. Implement Hydraulic Pump Output at Rated RPM	2 × 205 L/min	<b>2 × 54 gpm</b>	2 × 205 L/min	<b>2 × 54.2 gpm</b>	2 × 205 L/min	<b>2 × 54.2 gpm</b>	2 × 205 L/min	<b>2 × 54 gpm</b>
Relief Valve Settings:								
Implement Circuits	35 000 kPa	<b>5076 psi</b>	35 000 kPa	<b>5080 psi</b>	35 000 kPa	<b>5080 psi</b>	35 000 kPa	<b>5080 psi</b>
Travel Circuits	35 000 kPa	<b>5076 psi</b>	35 000 kPa	<b>5080 psi</b>	35 000 kPa	<b>5080 psi</b>	35 000 kPa	<b>5080 psi</b>
Swing Circuits	25 000 kPa	<b>3630 psi</b>	25 000 kPa	<b>3625 psi</b>	25 000 kPa	<b>3625 psi</b>	25 000 kPa	<b>3625 psi</b>
Pilot Circuits	3900 kPa	<b>566 psi</b>	3900 kPa	<b>566 psi</b>	3900 kPa	<b>566 psi</b>	3900 kPa	<b>566 psi</b>
Maximum Drawbar Pull	206 kN	<b>46,311 lb</b>	206 kN	<b>46,350 lb</b>	206 kN	<b>46,350 lb</b>	206 kN	<b>46,350 lb</b>
Maximum Travel Speed at Rated RPM	<b>Two Speed Travel</b> Lo: 3.5 km/h <b>2.2 mph</b> Hi: 5.5 km/h <b>3.4 mph</b>		<b>Two Speed Travel</b> Lo: 3.5 km/h <b>2.2 mph</b> Hi: 5.5 km/h <b>3.4 mph</b>		<b>Two Speed Travel</b> Lo: 3.5 km/h <b>2.2 mph</b> Hi: 5.7 km/h <b>3.5 mph</b>		<b>Two Speed Travel</b> Lo: 3.5 km/h <b>2.2 mph</b> Hi: 5.5 km/h <b>3.4 mph</b>	
Width of Standard Track Shoe	800 mm	<b>2'8"</b>	600 mm	<b>24"</b>	600 mm	<b>24"</b>	500 mm	<b>20"</b>
Overall Track Length	4450 mm	<b>14'7"</b>	4450 mm	<b>14'7"</b>	4455 mm	<b>14'7"</b>	4450 mm	<b>14'7"</b>
Ground Contact Area with Std. Shoe	4.72 m <sup>2</sup>	<b>7320 in<sup>2</sup></b>	4.3 m <sup>2</sup>	<b>6665 in<sup>2</sup></b>	4.3 m <sup>2</sup>	<b>6665 in<sup>2</sup></b>	3.6 m <sup>2</sup>	<b>5580 in<sup>2</sup></b>
Track Gauge	2380 mm	<b>7'10"</b>	2380 mm	<b>7'10"</b>	2380 mm	<b>7'10"</b>	1990 mm	<b>6'6"</b>
Fuel Tank Refill Capacity	330 L	<b>87 U.S. gal</b>	410 L	<b>108 U.S. gal</b>	410 L	<b>108 U.S. gal</b>	310 L	<b>108 U.S. gal</b>
Hydraulic System (includes tank)	208 L	<b>55 U.S. gal</b>	260 L	<b>69 U.S. gal</b>	260 L	<b>69 U.S. gal</b>	260 L	<b>69 U.S. gal</b>

\*Operating weight includes coolant, lubricants, full fuel tank, standard shoes, bucket and operator 75 kg (165 lb).

**NOTE:** Certain models may not be available in all Sales areas.

Specifications may also vary by Sales area.

Contact your Cat dealer for details.



MODEL	323D SA		324D		324D L		324D L	
Sourcing	Grenoble		Japan		Japan, U.S.		Belgium	
Flywheel Power	110 kW	<b>147 hp</b>	124 kW	<b>166 hp</b>	140 kW	<b>188 hp</b>	124 kW	<b>188 hp</b>
Operating Weight*	23 797 kg	<b>52,472 lb</b>	24 240 kg	<b>53,400 lb</b>	24 790 kg	<b>54,660 lb</b>	26 060 kg	<b>57,462 lb</b>
Bucket Capacity	0.41-1.7 m <sup>3</sup> <b>0.54-2.2 yd<sup>3</sup></b>		0.9-1.5 m <sup>3</sup> <b>1.18-1.96 yd<sup>3</sup></b>		0.5-2.0 m <sup>3</sup> <b>0.7-2.6 yd<sup>3</sup></b>		0.5-2.3 m <sup>3</sup> <b>0.65-3.01 yd<sup>3</sup></b>	
Engine Model	<b>3066 ATAAC</b>		<b>C7 ACERT</b>		<b>C7 ACERT</b>		<b>C7 ACERT</b>	
Rated Engine RPM	<b>1800</b>		<b>1800</b>		<b>1800</b>		<b>1800</b>	
No. of Cylinders	<b>6</b>		<b>6</b>		<b>6</b>		<b>6</b>	
Bore	102 mm	<b>4"</b>	110 mm	<b>4.3"</b>	110 mm	<b>4.3"</b>	110 mm	<b>4.3"</b>
Stroke	130 mm	<b>5"</b>	127 mm	<b>5"</b>	127 mm	<b>5"</b>	127 mm	<b>5"</b>
Displacement	6.4 L	<b>391 in<sup>3</sup></b>	7.2 L	<b>440 in<sup>3</sup></b>	7.2 L	<b>440 in<sup>3</sup></b>	7.2 L	<b>440 in<sup>3</sup></b>
Max. Implement Hydraulic Pump Output at Rated RPM	2 × 205 L/min	<b>2 × 54 gpm</b>	2 × 235 L/min	<b>2 × 62 gpm</b>	2 × 200 L/min	<b>2 × 58 gpm</b>	2 × 220 L/min	<b>2 × 58 gpm</b>
Relief Valve Settings:	Implement Circuits		Implement Circuits		Implement Circuits		Implement Circuits	
	35 000 kPa	<b>5080 psi</b>	35 000 kPa	<b>5076 psi</b>	35 000 kPa	<b>5076 psi</b>	35 000 kPa	<b>5076 psi</b>
	Travel Circuits	<b>5080 psi</b>	Travel Circuits	<b>5076 psi</b>	Travel Circuits	<b>5076 psi</b>	Travel Circuits	<b>5076 psi</b>
	35 000 kPa	<b>5080 psi</b>	35 000 kPa	<b>5076 psi</b>	35 000 kPa	<b>5076 psi</b>	35 000 kPa	<b>5076 psi</b>
	Swing Circuits	<b>3625 psi</b>	Swing Circuits	<b>3553 psi</b>	Swing Circuits	<b>3553 psi</b>	Swing Circuits	<b>3553 psi</b>
	25 000 kPa	<b>3625 psi</b>	24 500 kPa	<b>3553 psi</b>	24 500 kPa	<b>3553 psi</b>	24 500 kPa	<b>3553 psi</b>
	Pilot Circuits	<b>566 psi</b>	Pilot Circuits	<b>566 psi</b>	Pilot Circuits	<b>566 psi</b>	Pilot Circuits	<b>566 psi</b>
	3900 kPa	<b>566 psi</b>	3900 kPa	<b>566 psi</b>	3900 kPa	<b>566 psi</b>	3900 kPa	<b>566 psi</b>
Maximum Drawbar Pull	206 kN	<b>46,350 lb</b>	227 kN	<b>51,032 lb</b>	227 kN	<b>51,032 lb</b>	227 kN	<b>51,032 lb</b>
Maximum Travel Speed at Rated RPM	<b>Two Speed Travel</b> Lo: 2.9 km/h <b>1.8 mph</b> Hi: 4.5 km/h <b>2.8 mph</b>		5.5 km/h	<b>3.4 mph</b>	5.4 km/h	<b>3.4 mph</b>	5.4 km/h	<b>3.4 mph</b>
Width of Standard Track Shoe	550 mm	<b>1'9"</b>	600 mm	<b>2'0"</b>	800 mm	<b>2'8"</b>	800 mm	<b>2'8"</b>
Overall Track Length	4358 mm	<b>14'4"</b>	4250 mm	<b>13'11"</b>	4630 mm	<b>15'2"</b>	4630 mm	<b>15'2"</b>
Ground Contact Area with Std. Shoe	4.15 m <sup>2</sup>	<b>6433 in<sup>2</sup></b>	4.48 m <sup>2</sup>	<b>6938 in<sup>2</sup></b>	6.58 m <sup>2</sup>	<b>10,193 in<sup>2</sup></b>	6.58 m <sup>2</sup>	<b>10,200 in<sup>2</sup></b>
Track Gauge	1895 mm	<b>6'3"</b>	2390 mm	<b>7'10"</b>	2590 mm	<b>8'6"</b>	2590 mm	<b>8'6"</b>
Fuel Tank Refill Capacity	310 L	<b>82 U.S. gal</b>	520 L	<b>137 U.S. gal</b>	520 L	<b>137 U.S. gal</b>	520 L	<b>137 U.S. gal</b>
Hydraulic System (includes tank)	200 L	<b>52.8 U.S. gal</b>	300 L	<b>79.3 U.S. gal</b>	300 L	<b>79 U.S. gal</b>	300 L	<b>79 U.S. gal</b>

\*Operating weight includes coolant, lubricants, full fuel tank, standard shoes, bucket and operator 75 kg (165 lb).  
**NOTE:** Certain models may not be available in all Sales areas.  
 Specifications may also vary by Sales area.  
 Contact your Cat dealer for details.



MODEL	324D LN		328D LCR		329D		329D L	
Sourcing	Belgium		Japan		Japan		Japan, U.S.	
Flywheel Power	124 kW	<b>166 hp</b>	152 kW	<b>204 hp</b>	140 kW	<b>188 hp</b>	152 kW	<b>204 hp</b>
Operating Weight*	25 370 kg	<b>54,660 lb</b>	34 700 kg	<b>76,500 lb</b>	26 900 kg	<b>59,300 lb</b>	29 240 kg	<b>64,460 lb</b>
Bucket Capacity Range (heaped)	0.54-2.0 m <sup>3</sup>	<b>0.7-2.61 yd<sup>3</sup></b>	0.5-2.0 m <sup>3</sup>	<b>0.7-2.6 yd<sup>3</sup></b>	1.1-1.6 m <sup>3</sup>	<b>1.44-2.09 yd<sup>3</sup></b>	0.54-2.0 m <sup>3</sup>	<b>0.7-2.61 yd<sup>3</sup></b>
Engine Model	<b>C7 ACERT</b>		<b>C7 ACERT</b>		<b>C7 ACERT</b>		<b>C7 ACERT</b>	
Rated Engine RPM	<b>1800</b>		<b>1800</b>		<b>1800</b>		<b>1800</b>	
No. of Cylinders	<b>6</b>		<b>6</b>		<b>6</b>		<b>6</b>	
Bore	110 mm	<b>4.3"</b>	110 mm	<b>4.3"</b>	110 mm	<b>4.3"</b>	110 mm	<b>4.3"</b>
Stroke	127 mm	<b>5"</b>	127 mm	<b>5"</b>	127 mm	<b>5"</b>	127 mm	<b>5"</b>
Displacement	7.2 L	<b>440 in<sup>3</sup></b>	7.2 L	<b>440 in<sup>3</sup></b>	7.2 L	<b>439 in<sup>3</sup></b>	7.2 L	<b>440 in<sup>3</sup></b>
Max. Implement Hydraulic Pump Output at Rated RPM	2 × 220 L/min	<b>2 × 58 gpm</b>	2 × 235 L/min	<b>2 × 62 gpm</b>	2 × 235 L/min	<b>2 × 62 gpm</b>	2 × 235 L/min	<b>2 × 62 gpm</b>
Relief Valve Settings:								
Implement Circuits	35 000 kPa	<b>5076 psi</b>	35 000 kPa	<b>5076 psi</b>	35 000 kPa	<b>5076 psi</b>	35 000 kPa	<b>5076 psi</b>
Travel Circuits	35 000 kPa	<b>5076 psi</b>	35 000 kPa	<b>5076 psi</b>	35 000 kPa	<b>5076 psi</b>	35 000 kPa	<b>5076 psi</b>
Swing Circuits	24 500 kPa	<b>3553 psi</b>	27 500 kPa	<b>3989 psi</b>	27 500 kPa	<b>3988 psi</b>	27 500 kPa	<b>3989 psi</b>
Pilot Circuits	3900 kPa	<b>566 psi</b>	3900 kPa	<b>566 psi</b>	3900 kPa	<b>566 psi</b>	3900 kPa	<b>566 psi</b>
Maximum Drawbar Pull	227 kN	<b>51,032 lb</b>	300 kN	<b>67,443 lb</b>	249 kN	<b>55,977 lb</b>	249 kN	<b>55,977 lb</b>
Maximum Travel Speed at Rated RPM	5.4 km/h	<b>3.4 mph</b>	5.3 km/h	<b>3.3 mph</b>	4.2 km/h	<b>2.6 mph</b>	5.3 km/h	<b>3.3 mph</b>
Width of Standard Track Shoe	600 mm	<b>2'0"</b>	850 mm	<b>2'10"</b>	600 mm	<b>2'0"</b>	800 mm	<b>2'8"</b>
Overall Track Length	4630 mm	<b>15'2"</b>	5020 mm	<b>16'6"</b>	4360 mm	<b>14'4"</b>	4860 mm	<b>15'11"</b>
Ground Contact Area with Std. Shoe	4.93 m <sup>2</sup>	<b>7644 in<sup>2</sup></b>	7.45 m <sup>2</sup>	<b>11,549 in<sup>2</sup></b>	4.55 m <sup>2</sup>	<b>7058 in<sup>2</sup></b>	6.87 m <sup>2</sup>	<b>10,650 in<sup>2</sup></b>
Track Gauge	2390 mm	<b>7'10"</b>	2590 mm	<b>8'6"</b>	2390 mm	<b>7'10"</b>	2590 mm	<b>8'6"</b>
Fuel Tank Refill Capacity	520 L	<b>137 U.S. gal</b>	406 L	<b>106 U.S. gal</b>	520 L	<b>137 U.S. gal</b>	520 L	<b>137 U.S. gal</b>
Hydraulic System (includes tank)	300 L	<b>79 U.S. gal</b>	290 L	<b>76.6 U.S. gal</b>	310 L	<b>82 U.S. gal</b>	310 L	<b>82 U.S. gal</b>

\*Operating weight includes coolant, lubricants, full fuel tank, standard shoes, bucket and operator 75 kg (165 lb).

NOTE: Certain models may not be available in all Sales areas.

Specifications may also vary by Sales area.

Contact your Cat dealer for details.



MODEL	329D L		329D LN		336D		336D L	
Sourcing	Belgium		Belgium		Japan		Japan, U.S., Brazil	
Flywheel Power	140 kW	<b>188 hp</b>	140 kW	<b>188 hp</b>	200 kW	<b>268 hp</b>	200 kW	<b>268 hp</b>
Operating Weight*	29 560 kg	<b>65,180 lb</b>	28 540 kg	<b>62,931 lb</b>	33 750 kg	<b>74,400 lb</b>	36 151 kg	<b>79,700 lb</b>
Bucket Capacity	0.54-2.0 m <sup>3</sup> <b>0.7-2.61 yd<sup>3</sup></b>		0.54-2.0 m <sup>3</sup> <b>0.7-2.61 yd<sup>3</sup></b>		1.4-2.0 m <sup>3</sup> <b>1.83-2.49 yd<sup>3</sup></b>		0.7-2.2 m <sup>3</sup> <b>0.9-3.0 yd<sup>3</sup></b>	
Engine Model	<b>C7 ACERT</b>		<b>C7 ACERT</b>		<b>C9 ACERT</b>		<b>C9 ACERT</b>	
Rated Engine RPM	<b>1800</b>		<b>1800</b>		<b>1800</b>		<b>1800</b>	
No. of Cylinders	<b>6</b>		<b>6</b>		<b>6</b>		<b>6</b>	
Bore	110 mm	<b>4.3"</b>	110 mm	<b>4.3"</b>	112 mm	<b>4.4"</b>	112 mm	<b>4.4"</b>
Stroke	127 mm	<b>5"</b>	127 mm	<b>5"</b>	149 mm	<b>5.9"</b>	149 mm	<b>5.9"</b>
Displacement	7.2 L	<b>440 in<sup>3</sup></b>	7.2 L	<b>440 in<sup>3</sup></b>	8.8 L	<b>537 in<sup>3</sup></b>	8.8 L	<b>537 in<sup>3</sup></b>
Max. Implement Hydraulic Pump Output at Rated RPM	2 × 235 L/min	<b>2 × 62 gpm</b>	2 × 235 L/min	<b>2 × 62 gpm</b>	2 × 280 L/min	<b>2 × 74 gpm</b>	2 × 280 L/min	<b>2 × 74 gpm</b>
Relief Valve Settings:								
Implement Circuits	35 000 kPa	<b>5076 psi</b>	35 000 kPa	<b>5076 psi</b>	35 000 kPa	<b>5076 psi</b>	35 000 kPa	<b>5076 psi</b>
Travel Circuits	35 000 kPa	<b>5076 psi</b>	35 000 kPa	<b>5076 psi</b>	35 000 kPa	<b>5076 psi</b>	35 000 kPa	<b>5076 psi</b>
Swing Circuits	27 500 kPa	<b>3989 psi</b>	27 500 kPa	<b>3989 psi</b>	28 000 kPa	<b>4061 psi</b>	28 000 kPa	<b>4061 psi</b>
Pilot Circuits	3900 kPa	<b>566 psi</b>	3900 kPa	<b>566 psi</b>	3900 kPa	<b>566 psi</b>	4000 kPa	<b>566 psi</b>
Maximum Drawbar Pull	249 kN	<b>55,977 lb</b>	249 kN	<b>55,977 lb</b>	300 kN	<b>67,443 lb</b>	300 kN	<b>67,443 lb</b>
Maximum Travel Speed at Rated RPM	5.3 km/h	<b>3.3 mph</b>	5.3 km/h	<b>3.3 mph</b>	5.0 km/h	<b>3.1 mph</b>	5.0 km/h	<b>3.11 mph</b>
Track Shoe Width	800 mm	<b>2'8"</b>	600 mm	<b>2'0"</b>	700 mm	<b>2'4"</b>	800 mm	<b>2'8"</b>
Overall Track Length	4860 mm	<b>15'11"</b>	4860 mm	<b>16'0"</b>	4590 mm	<b>15'1"</b>	5020 mm	<b>16'6"</b>
Ground Contact Area with Std. Shoe	6.58 m <sup>2</sup>	<b>10,200 in<sup>2</sup></b>	5.03 m <sup>2</sup>	<b>7794 in<sup>2</sup></b>	5.53 m <sup>2</sup>	<b>8570 in<sup>2</sup></b>	7.01 m <sup>2</sup>	<b>10,872 in<sup>2</sup></b>
Track Gauge	2590 mm	<b>8'6"</b>	2390 mm	<b>7'10"</b>	2590 mm	<b>8'6"</b>	2590 mm	<b>8'6"</b>
Fuel Tank Refill Capacity	520 L	<b>137 U.S. gal</b>	520 L	<b>137 U.S. gal</b>	620 L	<b>163.8 U.S. gal</b>	620 L	<b>163.8 U.S. gal</b>
Hydraulic System (includes tank)	310 L	<b>82 U.S. gal</b>	310 L	<b>82 U.S. gal</b>	410 L	<b>108.3 U.S. gal</b>	410 L	<b>108.3 U.S. gal</b>

4

\*Operating weight includes coolant, lubricants, full fuel tank, standard shoes, bucket and operator 75 kg (165 lb).

NOTE: Certain models may not be available in all Sales areas.

Specifications may also vary by Sales area.

Contact your Cat dealer for details.





MODEL	336D L		336D LN	
Sourcing	Belgium		Belgium	
Flywheel Power	200 kW	268 hp	200 kW	268 hp
Operating Weight*	35 820 kg	78,983 lb	35 370 kg	77,991 lb
Bucket Capacity Range (heaped)	1.11-2.4 m <sup>3</sup>	1.45-3.14 yd <sup>3</sup>	1.11-2.4 m <sup>3</sup>	1.45-3.14 yd <sup>3</sup>
Engine Model	C9 ACERT		C9 ACERT	
Rated Engine RPM	1800		1800	
No. of Cylinders	6		6	
Bore	112 mm	4.4"	112 mm	4.4"
Stroke	149 mm	5.9"	149 mm	5.9"
Displacement	8.8 L	537 in <sup>3</sup>	8.8 L	537 in <sup>3</sup>
Max. Implement Hydraulic Pump Output at Rated RPM	2 × 280 L/min	2 × 74 gpm	2 × 280 L/min	2 × 74 gpm
Relief Valve Settings:				
Implement Circuits	35 000 kPa	5076 psi	35 000 kPa	5076 psi
Travel Circuits	35 000 kPa	5076 psi	35 000 kPa	5076 psi
Swing Circuits	28 000 kPa	4061 psi	28 000 kPa	4061 psi
Pilot Circuits	4000 kPa	566 psi	4000 kPa	566 psi
Maximum Drawbar Pull	300 kN	67,443 lb	300 kN	67,443 lb
Maximum Travel Speed at Rated RPM	5.0 km/h	3.11 mph	5.0 km/h	3.11 mph
Track Shoe Width	700 mm	2'4"	600 mm	2'0"
Overall Track Length	5020 mm	16'6"	5.02 m	16'6"
Ground Contact Area with Std. Shoe	5.74 m <sup>2</sup>	9987 in <sup>2</sup>	5.26 m <sup>2</sup>	8135 in <sup>2</sup>
Track Gauge	2590 mm	8'6"	2.39 m	7'10"
Fuel Tank Refill Capacity	620 L	164 U.S. gal	620 L	164 U.S. gal
Hydraulic System (includes tank)	410 L	108 U.S. gal	410 L	108 U.S. gal

\*Operating weight includes coolant, lubricants, full fuel tank, standard shoes, bucket and operator 75 kg (165 lb).

**NOTE:** Certain models may not be available in all Sales areas.

Specifications may also vary by Sales area.

Contact your Cat dealer for details.



MODEL	336E		336E L		336E L		336E LN	
Sourcing	Japan		Japan		Belgium		Belgium	
Flywheel Power	236 kW	<b>321 hp</b>	236 kW	<b>321 hp</b>	236 kW	<b>321 hp</b>	236 kW	<b>321 hp</b>
Operating Weight*	34 589 kg	<b>76,255 lb</b>	36 543 kg	<b>80,563 lb</b>	35 859 kg	<b>79,055 lb</b>	35 419 kg	<b>78,085 lb</b>
Bucket Capacity	1.4-2.0 m <sup>3</sup>	<b>1.83-2.49 yd<sup>3</sup></b>	1.4-2.0 m <sup>3</sup>	<b>1.83-2.49 yd<sup>3</sup></b>	1.4-2.0 m <sup>3</sup>	<b>1.83-2.49 yd<sup>3</sup></b>	1.4-2.0 m <sup>3</sup>	<b>1.83-2.49 yd<sup>3</sup></b>
Engine Model	<b>C9.3 ATAAC</b>		<b>C9.3 ATAAC</b>		<b>C9.3 ATAAC</b>		<b>C9.3 ATAAC</b>	
Rated Engine RPM	<b>1800</b>		<b>1800</b>		<b>1800</b>		<b>1800</b>	
No. of Cylinders	<b>6</b>		<b>6</b>		<b>6</b>		<b>6</b>	
Bore	115 mm	<b>4.5"</b>	115 mm	<b>4.5"</b>	115 mm	<b>4.5"</b>	115 mm	<b>4.5"</b>
Stroke	149 mm	<b>5.8"</b>	149 mm	<b>5.8"</b>	149 mm	<b>5.8"</b>	149 mm	<b>5.8"</b>
Displacement	9.3 L	<b>568 in<sup>3</sup></b>	9.3 L	<b>568 in<sup>3</sup></b>	9.3 L	<b>568 in<sup>3</sup></b>	9.3 L	<b>568 in<sup>3</sup></b>
Max. Implement Hydraulic Pump Output at Rated RPM	2 × 289 L/min	<b>2 × 76.5 gpm</b>	2 × 289 L/min	<b>2 × 76.5 gpm</b>	2 × 289 L/min	<b>2 × 76.5 gpm</b>	2 × 289 L/min	<b>2 × 76.5 gpm</b>
Relief Valve Settings:								
Implement Circuits	35 000 kPa	<b>5076 psi</b>	35 000 kPa	<b>5076 psi</b>	35 000 kPa	<b>5076 psi</b>	35 000 kPa	<b>5076 psi</b>
Travel Circuits	37 500 kPa	<b>5439 psi</b>	37 500 kPa	<b>5439 psi</b>	37 500 kPa	<b>5439 psi</b>	37 500 kPa	<b>5439 psi</b>
Swing Circuits	31 400 kPa	<b>4554 psi</b>	31 400 kPa	<b>4554 psi</b>	31 400 kPa	<b>4554 psi</b>	31 400 kPa	<b>4554 psi</b>
Pilot Circuits	4100 kPa	<b>595 psi</b>	4100 kPa	<b>595 psi</b>	4100 kPa	<b>595 psi</b>	4100 kPa	<b>595 psi</b>
Maximum Drawbar Pull	295 kN	<b>66,319 lb</b>	295 kN	<b>66,319 lb</b>	295 kN	<b>66,319 lb</b>	295 kN	<b>66,319 lb</b>
Maximum Travel Speed at Rated RPM	<b>Two Speed Travel</b> Lo: 3.1 km/h <b>1.9 mph</b> Hi: 4.8 km/h <b>3.0 mph</b>		<b>Two Speed Travel</b> Lo: 3.1 km/h <b>1.9 mph</b> Hi: 4.8 km/h <b>3.0 mph</b>		<b>Two Speed Travel</b> Lo: 3.1 km/h <b>1.9 mph</b> Hi: 4.8 km/h <b>3.0 mph</b>		<b>Two Speed Travel</b> Lo: 3.1 km/h <b>1.9 mph</b> Hi: 4.8 km/h <b>3.0 mph</b>	
Track Shoe Width	700 mm	<b>2'4"</b>	800 mm	<b>2'8"</b>	700 mm	<b>2'4"</b>	600 mm	<b>2'0"</b>
Overall Track Length	4590 mm	<b>15'1"</b>	5020 mm	<b>16'6"</b>	5020 mm	<b>16'6"</b>	5020 mm	<b>16'6"</b>
Ground Contact Area with Std. Shoe	5.53 m <sup>2</sup>	<b>8570 in<sup>2</sup></b>	7.02 m <sup>2</sup>	<b>10,881 in<sup>2</sup></b>	6.14 m <sup>2</sup>	<b>9517 in<sup>2</sup></b>	5.26 m <sup>2</sup>	<b>8135 in<sup>2</sup></b>
Track Gauge	2590 mm	<b>8'6"</b>	2590 mm	<b>8'6"</b>	2590 mm	<b>8'6"</b>	2390 mm	<b>7'10"</b>
Fuel Tank Refill Capacity	620 L	<b>163.8 U.S. gal</b>	620 L	<b>163.8 U.S. gal</b>	620 L	<b>163.8 U.S. gal</b>	620 L	<b>163.8 U.S. gal</b>
Hydraulic System (includes tank)	380 L	<b>100.4 U.S. gal</b>	380 L	<b>100.4 U.S. gal</b>	380 L	<b>100.4 U.S. gal</b>	380 L	<b>100.4 U.S. gal</b>
Hydraulic Tank	175 L	<b>46.2 U.S. gal</b>	175 L	<b>46.2 U.S. gal</b>	175 L	<b>46.2 U.S. gal</b>	175 L	<b>46.2 U.S. gal</b>

\*Operating weight includes coolant, lubricants, full fuel tank, standard shoes, bucket and operator 75 kg (165 lb).

**NOTE:** Certain models may not be available in all Sales areas.

Specifications may also vary by Sales area.

Contact your Cat dealer for details.



MODEL	345D L – FIX		345D L – VG		345D L – VG	
Sourcing	Japan, U.S.		U.S.		Belgium	
Flywheel Power	283 kW	<b>380 hp</b>	283 kW	<b>380 hp</b>	283 kW	<b>380 hp</b>
Operating Weight*	45 375 kg	<b>100,040 lb</b>	46 970 kg	<b>108,610 lb</b>	52 230 kg	<b>115,167 lb</b>
Bucket Capacity Range (heaped)	1.0-3.1 m <sup>3</sup>	<b>1.3-4.03 yd<sup>3</sup></b>	1.0-3.1 m <sup>3</sup>	<b>1.32-4.03 yd<sup>3</sup></b>	2.0-3.6 m <sup>3</sup>	<b>3.0-5.0 yd<sup>3</sup></b>
Engine Model	<b>C13 ACERT</b>		<b>C13 ACERT</b>		<b>C13 ACERT</b>	
Rated Engine RPM	<b>1800</b>		<b>1800</b>		<b>1800</b>	
No. of Cylinders	<b>6</b>		<b>6</b>		<b>6</b>	
Bore	130 mm	<b>5.1"</b>	130 mm	<b>5.1"</b>	130 mm	<b>5.1"</b>
Stroke	157 mm	<b>6.2"</b>	157 mm	<b>6.2"</b>	157 mm	<b>6.2"</b>
Displacement	12.5 L	<b>736 in<sup>3</sup></b>	12.5 L	<b>736 in<sup>3</sup></b>	12.5 L	<b>736 in<sup>3</sup></b>
Max. Implement Hydraulic Pump Output at Rated RPM	2 × 360 L/min	<b>2 × 95 gpm</b>	2 × 360 L/min	<b>2 × 95 gpm</b>	2 × 367 L/min	<b>2 × 97 gpm</b>
Relief Valve Settings:						
Implement Circuits	35 000 kPa	<b>5080 psi</b>	35 000 kPa	<b>5080 psi</b>	35 000 kPa	<b>5080 psi</b>
Travel Circuits	35 000 kPa	<b>5080 psi</b>	35 000 kPa	<b>5080 psi</b>	35 000 kPa	<b>5080 psi</b>
Swing Circuits	31 400 kPa	<b>4550 psi</b>	31 400 kPa	<b>4550 psi</b>	31 400 kPa	<b>4550 psi</b>
Pilot Circuits	4110 kPa	<b>596 psi</b>	4110 kPa	<b>596 psi</b>	4100 kPa	<b>596 psi</b>
Maximum Drawbar Pull	331 kN	<b>74,380 lb</b>	331 kN	<b>74,380 lb</b>	338 kN	<b>76,050 lb</b>
	<b>Two Speed Travel</b>		<b>Two Speed Travel</b>			
Maximum Travel Speed at Rated RPM	Lo: 3.5 km/h	<b>2.2 mph</b>	Lo: 3.5 km/h	<b>2.2 mph</b>	4.7 km/h	<b>3.0 mph</b>
	Hi: 4.7 km/h	<b>2.9 mph</b>	Hi: 4.7 km/h	<b>2.9 mph</b>		
Track Shoe Width	750 mm	<b>2'6"</b>	750 mm	<b>2'6"</b>	600 mm	<b>2'0"</b>
Overall Track Length	5.36 m	<b>17'7"</b>	5.34 m	<b>17'6"</b>	5330 mm	<b>17'6"</b>
Ground Contact Area with Std. Shoe	7.07 m <sup>2</sup>	<b>10,960 in<sup>2</sup></b>	5.63 m <sup>2</sup>	<b>8730 in<sup>2</sup></b>	5.21 m <sup>2</sup>	<b>8045 in<sup>2</sup></b>
Track Gauge	2.74 m	<b>9'0"</b>	2.4 m	<b>7'10"</b>	2390 mm	<b>7'10"</b>
Extended	—		2.89 m	<b>9'6"</b>	2890 mm	<b>9'6"</b>
Fuel Tank Refill Capacity	705 L	<b>186 U.S. gal</b>	705 L	<b>186 U.S. gal</b>	710 L	<b>188 U.S. gal</b>
Hydraulic System (includes tank)	570 L	<b>150 U.S. gal</b>	570 L	<b>150 U.S. gal</b>	570 L	<b>151 U.S. gal</b>
Hydraulic Tank	—		—		262 L	<b>69 U.S. gal</b>

\*Operating weight for 345D L – FIX and 345D L – VG (U.S. Sourced) includes coolant, lubricants, full fuel tank, standard shoes, bucket and operator 75 kg (165 lb). Operating weight for 345D L – VG (Belgium Sourced) includes coolant, lubricants, full fuel tank, one-piece boom, long stick, small profile bucket, operator 75 kg (165 lb) and wide shoes (standard shoes on 345D L – VG).

**NOTE:** Certain models may not be available in all Sales areas. Specifications may also vary by Sales area. Contact your Cat dealer for details.



MODEL	365C L		374D L		385C	
Sourcing	Belgium		Belgium		Belgium	
Flywheel Power	301 kW	<b>404 hp</b>	355 kW	<b>476 hp</b>	390 kW	<b>523 hp</b>
Operating Weight*	70 348 kg	<b>155,117 lb</b>	71 132 kg	<b>156,819 lb</b>	84 128 kg	<b>185,502 lb</b>
Bucket Capacity Range (heaped)	1.54-3.28 m <sup>3</sup>	<b>2.02-4.29 yd<sup>3</sup></b>	—		2.06-4.66 m <sup>3</sup>	<b>2.69-6.1 yd<sup>3</sup></b>
Engine Model	<b>C15 ACERT</b>		<b>C15 ACERT (ATAAC)</b>		<b>C18 ACERT</b>	
Rated Engine RPM	<b>1800</b>		<b>1800</b>		<b>1800</b>	
No. of Cylinders	<b>6</b>		<b>6</b>		<b>6</b>	
Bore	137 mm	<b>5.4"</b>	137 mm	<b>5.4"</b>	145 mm	<b>5.71"</b>
Stroke	171 mm	<b>6.75"</b>	171 mm	<b>6.75"</b>	183 mm	<b>7.2"</b>
Displacement	15.2 L	<b>928 in<sup>3</sup></b>	15.2 L	<b>928 in<sup>3</sup></b>	18.1 L	<b>1104 in<sup>3</sup></b>
Max. Implement Hydraulic Pump Output at Rated RPM	2 × 400 L/min	<b>2 × 105 gpm</b>	2 × 440 L/min	<b>2 × 116 gpm</b>	2 × 490 L/min	<b>2 × 129 gpm</b>
Relief Valve Settings:						
Implement Circuits	32 000 kPa	<b>4640 psi</b>	35 000 kPa	<b>5076 psi</b>	32 000 kPa	<b>4640 psi</b>
Travel Circuits	35 000 kPa	<b>5080 psi</b>	35 000 kPa	<b>5076 psi</b>	35 000 kPa	<b>5080 psi</b>
Swing Circuits	28 050 kPa	<b>4070 psi</b>	29 400 kPa	<b>4264 psi</b>	26 000 kPa	<b>3770 psi</b>
Pilot Circuits	4120 kPa	<b>600 psi</b>	4120 kPa	<b>600 psi</b>	4100 kPa	<b>590 psi</b>
Maximum Drawbar Pull	462 kN	<b>103,860 lb</b>	492.5 kN	<b>110,718 lb</b>	592 kN	<b>133,200 lb</b>
Maximum Travel	<b>Two Speed Travel</b>		<b>Two Speed Travel</b>		<b>Two Speed Travel</b>	
Speed at	Lo: 2.5 km/h	<b>1.6 mph</b>	Lo: 2.8 km/h	<b>1.7 mph</b>	Lo: 2.8 km/h	<b>1.7 mph</b>
Rated RPM	Hi: 3.9 km/h	<b>2.4 mph</b>	Hi: 4.1 km/h	<b>2.6 mph</b>	Hi: 4.5 km/h	<b>2.8 mph</b>
Track Shoe Width	750 mm	<b>2'6"</b>	650 mm	<b>2'1"</b>	650 mm	<b>2'1"</b>
Overall Track Length	5.86 m	<b>19'2"</b>	5870 mm	<b>19'3"</b>	5.84 m	<b>19'2"</b>
Ground Contact Area with Std. Shoe	7.06 m <sup>2</sup>	<b>10,943 in<sup>2</sup></b>	6.12 m <sup>2</sup>	<b>10,943 in<sup>2</sup></b>	6.54 m <sup>2</sup>	<b>10,137 in<sup>2</sup></b>
Track Gauge (shipping)	2.75 m	<b>9'0"</b>	2750 mm	<b>9'0"</b>	2.75 m	<b>9'0"</b>
Extended (working position)	3.25 m	<b>10'8"</b>	3410 mm	<b>11'2"</b>	3.51 m	<b>11'6"</b>
Fuel Tank Refill Capacity	800 L	<b>211 U.S. gal</b>	935 L	<b>247 U.S. gal</b>	1240 L	<b>328 U.S. gal</b>
Hydraulic System (includes tank)	670 L	<b>177 U.S. gal</b>	670 L	<b>177 U.S. gal</b>	995 L	<b>263 U.S. gal</b>
Hydraulic Tank	310 L	<b>82 U.S. gal</b>	310 L	<b>82 U.S. gal</b>	810 L	<b>214 U.S. gal</b>

\*Operating weight for 365C L includes coolant, lubricants, full fuel tank, one-piece boom, long stick, small profile bucket, operator 75 kg (165 lb) and wide shoes. Operating weight for 374D L includes coolant, lubricants, full fuel tank, boom, stick, bucket, operator 75 kg (165 lb) and standard shoes. Operating weight for 385C includes coolant, lubricants, full fuel tank, reach boom, medium stick configuration, bucket and operator 75 kg (165 lb) and 1500 kg (3300 lb) for attachments.

**NOTE:** Certain models may not be available in all Sales areas. Specifications may also vary by Sales area. Contact your Cat dealer for details.



MODEL	385C L		390D		390D L	
Sourcing	Belgium		Belgium		Belgium	
Flywheel Power	390 kW	<b>523 hp</b>	390 kW	<b>523 hp</b>	390 kW	<b>523 hp</b>
Operating Weight*	86 549 kg	<b>190,840 lb</b>	84 501 kg	<b>186,293 lb</b>	86 190 kg	<b>190,016 lb</b>
Bucket Capacity Range (heaped)	2.06-4.66 m <sup>3</sup>	<b>2.69-6.1 yd<sup>3</sup></b>	—		—	
Engine Model	<b>C18 ACERT</b>		<b>C18 ACERT</b>		<b>C18 ACERT</b>	
Rated Engine RPM	<b>1800</b>		<b>1800</b>		<b>1800</b>	
No. of Cylinders	<b>8</b>		<b>6</b>		<b>6</b>	
Bore	145 mm	<b>5.71"</b>	145 mm	<b>5.7"</b>	145 mm	<b>5.7"</b>
Stroke	183 mm	<b>7.2"</b>	171 mm	<b>6.75"</b>	171 mm	<b>6.75"</b>
Displacement	18.1 L	<b>1104 in<sup>3</sup></b>	18.1 L	<b>1106 in<sup>3</sup></b>	18.1 L	<b>1106 in<sup>3</sup></b>
Max. Implement Hydraulic Pump Output at Rated RPM	2 × 490 L/min	<b>2 × 129 gpm</b>	2 × 490 L/min	<b>2 × 130 gpm</b>	2 × 490 L/min	<b>2 × 130 gpm</b>
Relief Valve Settings:						
Implement Circuits	32 000 kPa	<b>4640 psi</b>	35 000 kPa	<b>5080 psi</b>	35 000 kPa	<b>5080 psi</b>
Travel Circuits	35 000 kPa	<b>5080 psi</b>	35 000 kPa	<b>5080 psi</b>	35 000 kPa	<b>5080 psi</b>
Swing Circuits	26 000 kPa	<b>3770 psi</b>	26 000 kPa	<b>3770 psi</b>	26 000 kPa	<b>3770 psi</b>
Pilot Circuits	4100 kPa	<b>590 psi</b>	4120 kPa	<b>600 psi</b>	4120 kPa	<b>600 psi</b>
Maximum Drawbar Pull	592 kN	<b>133,200 lb</b>	590 kN	<b>133,090 lb</b>	590 kN	<b>133,090 lb</b>
Maximum Travel	<b>Two Speed Travel</b>		<b>Two Speed Travel</b>		<b>Two Speed Travel</b>	
Speed at	Lo: 2.8 km/h	<b>1.7 mph</b>	Lo: 2.8 km/h	<b>1.7 mph</b>	Lo: 2.8 km/h	<b>1.7 mph</b>
Rated RPM	Hi: 4.5 km/h	<b>2.8 mph</b>	Hi: 4.5 km/h	<b>2.8 mph</b>	Hi: 4.5 km/h	<b>2.8 mph</b>
Track Shoe Width	750 mm	<b>2'6"</b>	650 mm	<b>2'1"</b>	650 mm	<b>2'1"</b>
Overall Track Length	6.36 m	<b>20'10"</b>	5840 mm	<b>19'2"</b>	6360 mm	<b>20'9"</b>
Ground Contact Area with Std. Shoe	7.22 m <sup>2</sup>	<b>11,191 in<sup>2</sup></b>	6.54 m <sup>2</sup>	<b>10,137 in<sup>2</sup></b>	7.22 m <sup>2</sup>	<b>11,191 in<sup>2</sup></b>
Track Gauge (shipping)	2.75 m	<b>9'0"</b>	2750 mm	<b>9'0"</b>	2750 mm	<b>9'0"</b>
Extended (working position)	3.51 m	<b>11'6"</b>	3510 mm	<b>11'6"</b>	3510 mm	<b>11'6"</b>
Fuel Tank Refill Capacity	1240 L	<b>328 U.S. gal</b>	1240 L	<b>328 U.S. gal</b>	1240 L	<b>328 U.S. gal</b>
Hydraulic System (includes tank)	995 L	<b>263 U.S. gal</b>	995 L	<b>263 U.S. gal</b>	995 L	<b>263 U.S. gal</b>
Hydraulic Tank	810 L	<b>214 U.S. gal</b>	810 L	<b>214 U.S. gal</b>	810 L	<b>214 U.S. gal</b>

\*Operating weight for 385C L includes coolant, lubricants, full fuel tank, reach boom, medium stick configuration, bucket and operator 75 kg (165 lb) and 1500 kg (3300 lb) for attachments.

Operating weight for 390D and 390D L includes coolant, lubricants, full fuel tank, boom, stick, bucket and operator 75 kg (165 lb) and standard shoes.

**NOTE:** Certain models may not be available in all Sales areas.

Specifications may also vary by Sales area.  
Contact your Cat dealer for details.

**SHIPPING DIMENSIONS KEYS****301.6 through 385**

---

- A Cab height
  - B House width, without mirrors
  - C Track width, standard shoe
  - D Ground clearance, frame
  - E Ground clearance, counterweight
  - F Tail swing radius
  - G Overall track length  
(grouser bar to grouser bar)
  - H Overall transport length
  - J Shipping height
  - K Length of track on ground
  - L Track gauge
- 

**M313D through M322D**

---

- A Cab height
  - B Transport width
  - C Overall tire width
  - D Ground clearance, frame
  - E Transport length without boom
  - F Overall transport length
  - G Transport height
  - H Ground clearance, counterweight
  - J Tail swing radius
  - K Wheelbase length
  - L Overall width  
(outrigger to outrigger)
-

# Excavators

## Shipping Dimensions

- 301.6C ● 301.8C ● 302.5C ● 303C CR
- 303.5C CR ● 304C CR ● 305C CR
- 305.5 ● 307D ● 308D CR ● 308D CR SB

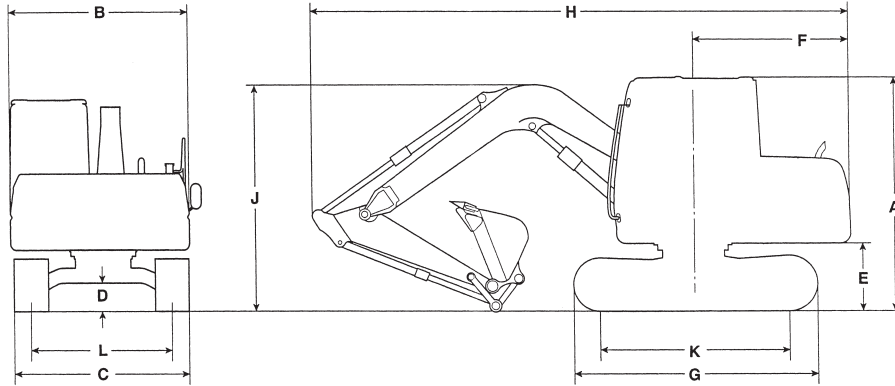

	301.6C		301.8C		302.5C		303C CR		303.5C CR		304C CR		305C CR	
Sourcing	U.K.		U.K.		U.K.		Japan		Japan		Japan		Japan	
	mm	ft	mm	ft	mm	ft	mm	ft	mm	ft	mm	ft	mm	ft
<b>A</b>	2190	7'2"	2190	7'2"	2300	7'7"	2500	8'2"	2500	8'2"	2550	8'4"	2550	8'4"
<b>B</b>	980	3'3"	980	3'3"	1450	4'9"	1550	5'1"	1780	5'10"	1980	6'6"	1980	6'6"
<b>C</b>	980	3'3"	980	3'3"	1450	4'9"	1550	5'1"	1780	5'10"	1980	6'6"	1980	6'6"
<b>D</b>	—	—	—	—	—	—	—	—	—	—	—	—	—	—
<b>E</b>	435	1'5"	435	1'5"	545	1'9"	565	1'10"	565	1'10"	615	2'0"	615	2'0"
<b>F</b>	1090	3'7"	1090	3'7"	1280	4'2"	775	2'7"	890	2'11"	990	3'3"	990	3'3"
<b>G</b>	1575	5'2"	1575	5'2"	1925	6'4"	2220	7'3"	2220	7'3"	2580	8'6"	2580	8'6"
<b>H*</b>	3695	12'1"	3695	12'1"	4515	14'10"	4730	15'6"	4820	15'10"	5170	17'0"	5330	17'6"
<b>J*</b>	—	—	—	—	—	—	—	—	—	—	—	—	—	—
<b>K</b>	—	—	—	—	—	—	—	—	—	—	—	—	—	—
<b>L</b>	750	2'6"	750	2'6"	1150	3'9"	1250	4'1"	1480	4'10"	1580	5'2"	1580	5'2"

	305.5**		307D		308D CR		308D CR SB	
Sourcing	China		Japan		Japan		Japan	
	mm	ft	mm	ft	mm	ft	mm	ft
<b>A</b>	2545	8'4"	2630	8'8"	2590	8'6"	2590	8'6"
<b>B</b>	1880	6'2"	2230	7'4"	2320	7'7"	2320	7'7"
<b>C</b>	1950	6'5"	2290	7'6"	2320	7'7"	2320	7'7"
<b>D</b>	330	1'1"	380	1'5"	384	1'5"	380	1'5"
<b>E</b>	640	2'1"	760	2'6"	735	2'5"	735	2'5"
<b>F</b>	1635	5'5"	1750	2'6"	1290	4'3"	1310	4'4"
<b>G</b>	2450	8'0"	2760	9'1"	2910	9'7"	2910	9'7"
<b>H*</b>	5925	19'5"	5730	18'10"	6410	20'0"	5830	19'2"
<b>J*</b>	1760	5'10"	2725	8'11"	2240	7'4"	2740	9'0"
<b>K</b>	1920	6'4"	2120	6'11"	2280	7'6"	2120	6'11"
<b>L</b>	1550	5'1"	1840	5'9"	1870	6'2"	1870	6'2"

\*Varies with stick length.

\*\*China and Korea only.

Shipping Dimensions

- 311D LRR ● 312D ● 312D L
- 313C SR ● 313C CR ● 314D CR
- 314D LCR ● 315D L

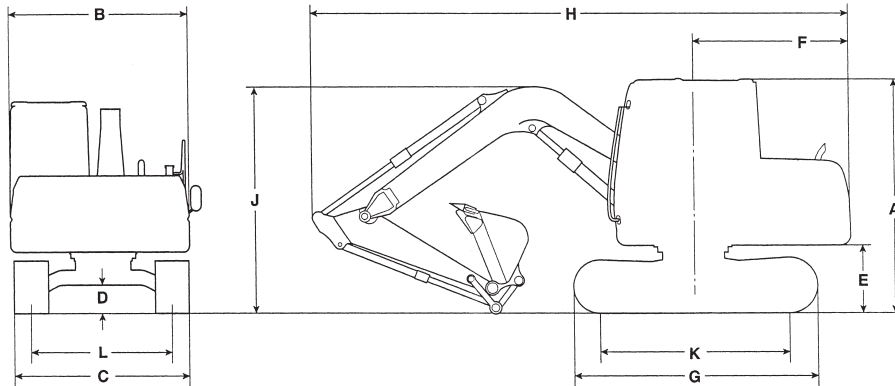

	311D LRR		312D		312D		312D L		312D L		313C SR		313C CR	
Sourcing	Japan		Japan		France		Japan		France		Japan		Japan	
	mm	ft	mm	ft	mm	ft	mm	ft	mm	ft	mm	ft	mm	ft
<b>A</b>	2755	9'0"	2760	9'1"	2760	9'1"	2760	9'1"	2760	9'1"	2730	8'11"	2730	8'11"
<b>B</b>	2490	8'2"	2510	8'3"	2490	8'2"	2510	8'3"	2490	8'2"	2490	8'2"	2490	8'2"
<b>C</b>	2490	8'2"	2590	8'6"	2490	8'2"	2590	8'6"	2490	8'2"	2490	8'2"	2490	8'2"
<b>D</b>	455	18"	430	17"	430	1'5"	430	17"	430	1'5"	455	18"	455	18"
<b>E</b>	910	3'0"	915	3'0"	915	3'0"	915	3'0"	915	3'0"	915	3'0"	915	3'0"
<b>F</b>	1750	5'9"	2140	7'0"	2140	7'0"	2140	7'0"	2140	7'0"	1420	4'8"	1420	4'8"
<b>G</b>	3490	11'5"	3490	11'5"	3490	11'5"	3750	12'4"	3750	12'4"	3490	11'5"	3490	11'5"
<b>H*</b>	6825	22'5"	7610	25'0"	7610	25'0"	7610	25'0"	7610	25'0"	7480	24'6"	7280	23'11"
<b>J*</b>	3160	10'4"	2830	9'3"	2970	9'8"	2830	9'3"	2970	9'8"	2730	8'11"	2810	9'3"
<b>K</b>	2780	9'1"	2780	9'1"	2780	9'1"	3040	10'0"	3040	10'0"	2780	9'1"	2780	9'1"
<b>L</b>	1990	6'6"	1990	6'6"	1990	6'6"	1990	6'6"	1990	6'6"	1990	6'6"	1990	6'6"

	314D CR		314D LCR		315D L	
Sourcing	Japan		Japan		Japan, France	
	mm	ft	mm	ft	mm	ft
<b>A</b>	2730	8'11"	2730	8'11"	2870	9'4"
<b>B</b>	2490	8'2"	2490	8'2"	2490	8'2"
<b>C</b>	2490	8'2"	2490	8'2"	2590	8'6"
<b>D</b>	430	17"	430	17"	460	18"
<b>E</b>	895	2'11"	895	2'11"	1030	3'5"
<b>F</b>	1480	4'10"	1480	4'10"	2500	8'2"
<b>G</b>	3490	11'5"	3750	12'4"	3970	13'0"
<b>H*</b>	7410	24'4"	7410	24'4"	8545	28'0"
<b>J*</b>	2910	9'7"	2910	9'7"	3360	11'0"
<b>K</b>	2780	9'1"	3040	10'0"	3170	10'5"
<b>L</b>	1990	6'6"	1990	6'6"	1990	6'6"

\*Varies with stick length.



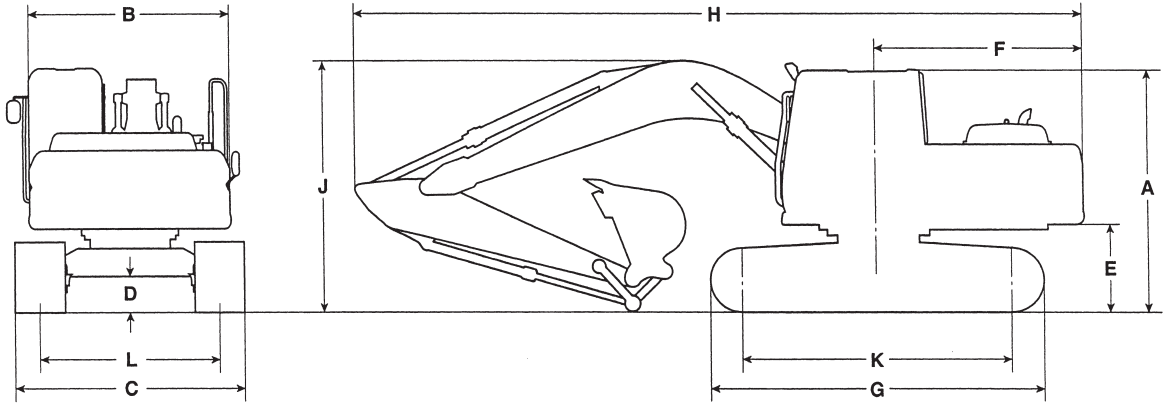

Sourcing	319D L		319D LN	
	France		France	
	mm	ft	mm	ft
<b>A</b>	2870	9'5"	2870	9'5"
<b>B</b>	2490	8'2"	2490	8'2"
<b>C</b>	2800	9'2"	2495	8'2"
<b>D</b>	463	18"	463	18"
<b>E</b>	1027	3'4"	1027	3'4"
<b>F</b>	2480	8'2"	2480	8'2"
<b>G</b>	4450	14'7"	4450	14'7"
<b>H*</b>	8775	28'9"	8775	28'9"
<b>J*</b>	3085	10'1"	3085	10'1"
<b>K</b>	3650	12'0"	3650	12'0"
<b>L</b>	2200	7'3"	1995	6'7"

\*Varies with stick length.

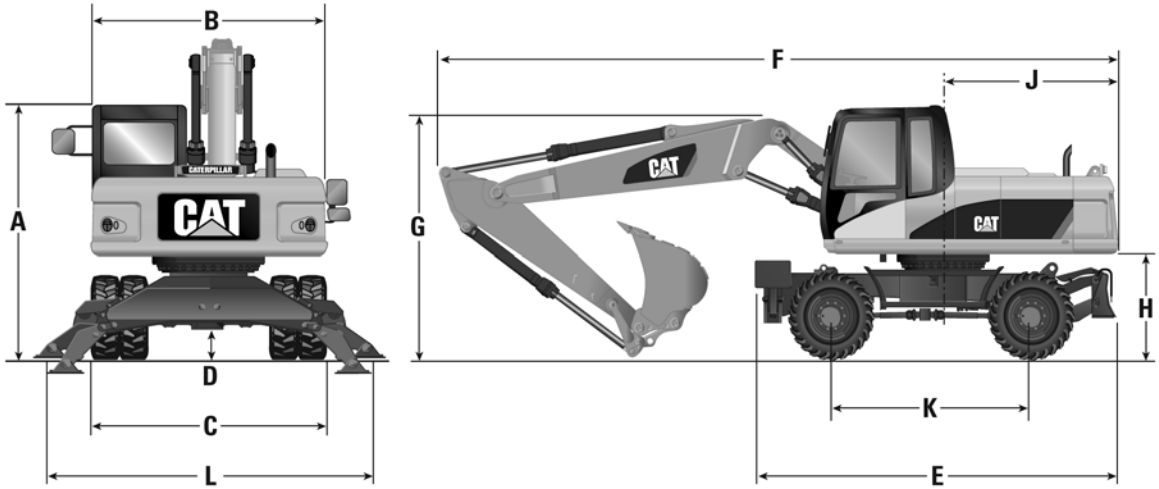

	M313D		M315D		M316D		M318D		M322D	
	mm	ft	mm	ft	mm	ft	mm	ft	mm	ft
<b>A</b>	3120	10'3"	3150	10'4"	3170	10'5"	3170	10'5"	3200	10'6"
<b>B</b>	2540	8'4"	2540	8'4"	2540	8'4"	2540	8'4"	2670	8'9"
<b>C*</b>	2550	8'4"	2550	8'4"	2550	8'4"	2550	8'4"	2750	9'0"
<b>Dozer width</b>	2550	8'4"	2550	8'4"	2550	8'4"	2550	8'4"	2750	9'0"
<b>D</b>	370	1'3"	370	1'3"	370	1'3"	370	1'3"	380	1'3"
<b>E<sup>1</sup></b>	4725	15'6"	4775	15'8"	4825	15'10"	4825	15'10"	5025	16'6"
<b>E<sup>2</sup></b>	4965	16'3"	5015	16'5"	4860	15'11"	4860	15'11"	5060	16'7"
<b>E<sup>3</sup></b>	4355	14'3"	4610	15'1"	4330	14'2"	4250	13'11"	4410	14'6"
<b>F</b>	8080	26'6"	8330	27'4"	8400	27'7"	8960	29'5"	9640	31'7"
<b>G</b>	3120	10'3"	3150	10'4"	3170	10'5"	3210	10'6"	3250	10'8"
<b>H</b>	1230	4'0"	1260	4'2"	1280	4'2"	1275	4'2"	1310	4'4"
<b>J</b>	2050	6'9"	2215	7'3"	2280	7'6"	2500	8'2"	2750	9'0"
<b>K</b>	2500	8'2"	2550	8'4"	2600	8'6"	2600	8'6"	2750	9'0"
<b>L</b>	3665	12'0"	3665	12'0"	3675	12'1"	3676	12'1"	3940	12'11"

E<sup>1</sup> 2 Sets Outriggers.

E<sup>2</sup> Outriggers/Dozer.

E<sup>3</sup> Dozer only.

\*10 × 20 Dual Tires.

**NOTE:** Shipping dimensions above are for standard machine equipped with one-piece boom and medium stick.

# Excavators

## Shipping Dimensions

- 320D, 320D L — Japan/Brazil/China/Indonesia Sourced
- 320D RR, 320D LRR — Japan Sourced

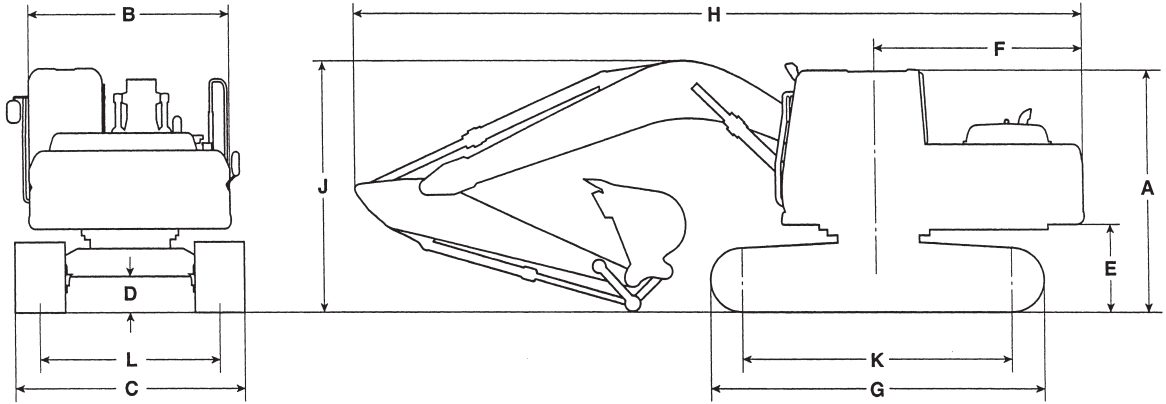

	320D Reach		320D Mass		320D RR Reach		320D L Reach		320D L Mass		320D LRR Reach	
Sourcing	Japan, Brazil, China, Indonesia		Japan, Brazil, China, Indonesia		Japan		Japan, Brazil, China, Indonesia		Japan, Brazil, China, Indonesia		Japan	
	mm	ft	mm	ft	mm	ft	mm	ft	mm	ft	mm	ft
<b>A</b>	2950	9'8"	2950	9'8"	2950	9'8"	2950	9'8"	2950	9'8"	2950	9'8"
<b>B</b>	2740	9'0"	2740	9'0"	2740	9'0"	2740	9'0"	2740	9'0"	2740	9'0"
<b>C</b>	2800	9'2"	2800	9'2"	2800	9'2"	3180	10'5"	3180	10'5"	2800	9'2"
<b>D</b>	450	1'6"	450	1'6"	450	1'6"	450	1'6"	450	1'6"	450	1'6"
<b>E</b>	1020	3'4"	1020	3'4"	1000	3'3"	1020	3'4"	1020	3'4"	1000	3'3"
<b>F</b>	2750	9'0"	2750	9'0"	2000	6'7"	2750	9'0"	2750	9'0"	2000	6'7"
<b>G</b>	4075	13'4"	4075	13'4"	4075	13'4"	4455	14'7"	4455	14'7"	4455	14'7"
<b>H</b>	9440	31'0"	9050	29'8"	8770	28'9"	9440	31'0"	9050	29'8"	8770	28'9"
<b>J*</b>	3440	11'3"	3280	10'9"	3030	9'11"	3440	11'3"	3440	11'3"	3030	9'11"
<b>K</b>	3265	10'9"	3265	10'9"	3265	10'9"	3650	12'0"	3650	12'0"	3650	12'0"
<b>L</b>	2200	7'3"	2200	7'3"	2200	7'3"	2380	7'10"	2380	7'10"	2380	7'10"

\*Varies with stick length.

\*\*Europe, Africa, Middle East — 2980 mm (9'8").

Shipping Dimensions

- 321D LCR — Japan Sourced
- 323D L — Belgium/Brazil/Japan/France/China Sourced
- 323D LN, 323D SA — France Sourced

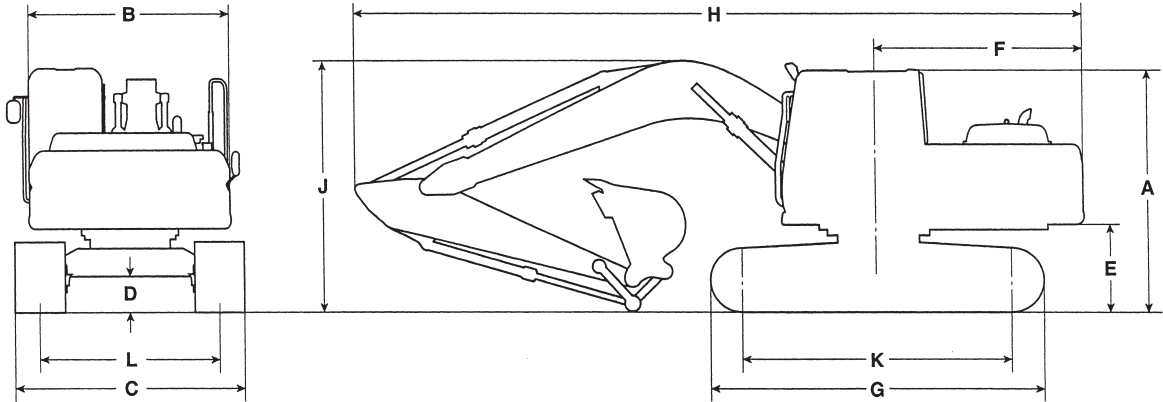

4

	321D LCR		321D LCR VA		323D L Reach		323D L Mass		323D L VA	
Sourcing	Japan		Japan		Belgium, Brazil		Belgium, Brazil, Japan		France	
	mm	ft	mm	ft	mm	ft	mm	ft	mm	ft
<b>A</b>	2960	9'9"	2980	9'9"	3050	10'0"	3050	10'0"	3050	10'0"
<b>B</b>	2980	9'9"	2980	9'9"	2750	9'0"	2750	9'0"	2750	9'0"
<b>C</b>	3180	** 10'5"	2980	9'9"	2980	9'9"	2980	9'9"	2980	9'9"
<b>D</b>	1003	3'3"	450	1'6"	460	1'8"	460	1'8"	460	1'8"
<b>E</b>	963	3'2"	980	3'3"	1000	3'3"	1000	3'3"	1000	3'3"
<b>F</b>	1680	5'6"	1676	5'6"	2770	9'1"	2770	9'1"	2770	9'1"
<b>G</b>	4455	14'7"	4455	14'7"	4455	14'7"	4455	14'7"	4455	14'7"
<b>H</b>	8830	29'0"	9200	30'2"	9460	31'0"	9260	30'4"	9700	31'10"
<b>J*</b>	3170	10'5"	3170	10'5"	3120	10'3"	3250	10'8"	3010	9'11"
<b>K</b>	3650	12'0"	3650	12'0"	3650	12'0"	3650	12'0"	3650	12'0"
<b>L</b>	2380	7'10"	2380	7'10"	2380	7'10"	2380	7'10"	2380	7'10"

	323D L Reach		323D L Mass		323D LN Reach		323D LN VA		323D SA Reach		323D SA VA	
Sourcing	China		China		France		France		France		France	
	mm	ft	mm	ft	mm	ft	mm	ft	mm	ft	mm	ft
<b>A</b>	2950	9'8"	2950	9'8"	3050	10'0"	3050	10'0"	3050	10'0"	3050	10'0"
<b>B</b>	—	—	—	—	2490	8'2"	2490	8'2"	2490	8'2"	2490	8'2"
<b>C</b>	3180	10'5"	3180	10'5"	2490	8'6"	2490	8'6"	2500	8'2"	2500	8'2"
<b>D</b>	450	1'6"	450	1'6"	460	1'8"	460	1'8"	480	1'9"	480	1'9"
<b>E</b>	1020	3'4"	1020	3'4"	1000	3'3"	1000	3'3"	1080	3'7"	1080	3'7"
<b>F</b>	2750	9'0"	2750	9'0"	2770	9'1"	2770	9'1"	2770	9'1"	2770	9'1"
<b>G</b>	4455	14'7"	4455	14'7"	4455	14'7"	4455	14'7"	4360	14'4"	4360	14'4"
<b>H</b>	9460	31'0"	9050	29'8"	9460	31'0"	9700	31'10"	9460	31'0"	9700	31'10"
<b>J*</b>	3050	10'0"	3280	10'10"	3120	10'3"	3010	9'11"	3160	10'4"	3090	10'2"
<b>K</b>	3650	12'0"	3650	12'0"	3650	12'0"	3650	12'0"	3490	11'5"	3490	11'5"
<b>L</b>	2380	7'10"	2380	7'10"	1995	6'7"	1995	6'7"	1895	6'3"	1895	6'3"

\*Varies with stick length.

\*\*Europe, Africa, Middle East — 2980 mm (8'3").

# Excavators

## Shipping Dimensions

- 324D, 324D L — Japan/U.S. Sourced
- 324D L, 324D LN — Belgium Sourced

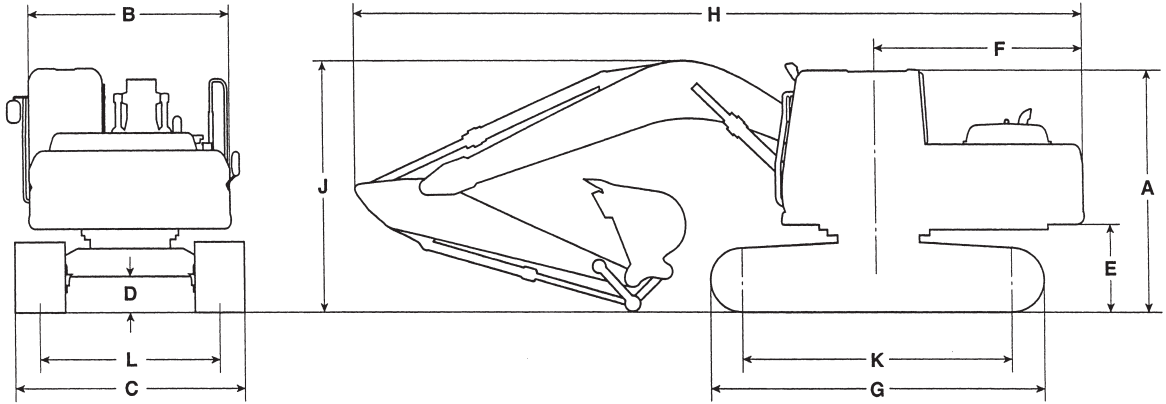

### Japan/U.S. Sourced

	324D Reach		324D Mass		324D L Reach		324D L Mass	
	mm	ft	mm	ft	mm	ft	mm	ft
<b>A</b>	2980	9'9"	2980	9'9"	2980	9'9"	2980	9'9"
<b>B</b>	2900	9'6"	2900	9'6"	2900	9'6"	2900	9'6"
<b>C</b>	2990	9'10"	2990	9'10"	3390	11'1"	3390	11'1"
<b>D</b>	470	1'6"	470	1'6"	440	1'5"	440	1'5"
<b>E</b>	1060	3'6"	1060	3'6"	1060	3'6"	1060	3'6"
<b>F</b>	2940	9'8"	2940	9'8"	3000	9'10"	3000	9'10"
<b>G</b>	4250	13'11"	4250	13'11"	4630	15'2"	4630	15'2"
<b>H*</b>	10 050	33'0"	9480	31'1"	10 050	33'0"	9480	31'1"
<b>J*</b>	3170	10'5"	3320	10'11"	3170	10'5"	3450	11'4"
<b>K</b>	3450	11'4"	3450	11'4"	3830	12'7"	3830	12'7"
<b>L</b>	2390	7'10"	2390	7'10"	2590	8'6"	2590	8'6"

### Belgium Sourced

	324D L Reach		324D L Mass		324D L VA		324D LN Reach		324D LN Mass		324D LN VA	
	mm	ft	mm	ft	mm	ft	mm	ft	mm	ft	mm	ft
<b>A</b>	2980	9'9"	2980	9'9"	2980	9'9"	2980	9'9"	2980	9'9"	2980	9'9"
<b>B</b>	2900	9'6"	2900	9'6"	2900	9'6"	2900	9'6"	2900	9'6"	2900	9'6"
<b>C</b>	3390	11'1"	3390	11'1"	3390	11'1"	2990	9'10"	2990	9'10"	2990	9'10"
<b>D</b>	440	1'5"	440	1'5"	440	1'5"	440	1'5"	440	1'5"	440	1'5"
<b>E</b>	1060	3'6"	1060	3'6"	1060	3'6"	1060	3'6"	1060	3'6"	1060	3'6"
<b>F</b>	3000	9'10"	3000	9'10"	3000	9'10"	3000	9'10"	3000	9'10"	3000	9'10"
<b>G</b>	4630	15'2"	4630	15'2"	4630	15'2"	4630	15'2"	4630	15'2"	4630	15'2"
<b>H*</b>	10 060	33'0"	9480	31'1"	10 210	33'6"	10 060	33'0"	9480	31'1"	10 210	33'6"
<b>J*</b>	3170	10'5"	3450	11'4"	3270	10'9"	3170	10'5"	3450	11'4"	3270	10'9"
<b>K</b>	3830	12'7"	3830	12'7"	3830	12'7"	3830	12'7"	3830	12'7"	3830	12'7"
<b>L</b>	2590	8'6"	2590	8'6"	2590	8'6"	2390	7'10"	2390	7'10"	2390	7'10"

\*Varies with stick length.

- 328D LCR, 329D, 329D L — Japan/U.S. Sourced
- 329D L, 329D LN — Belgium Sourced

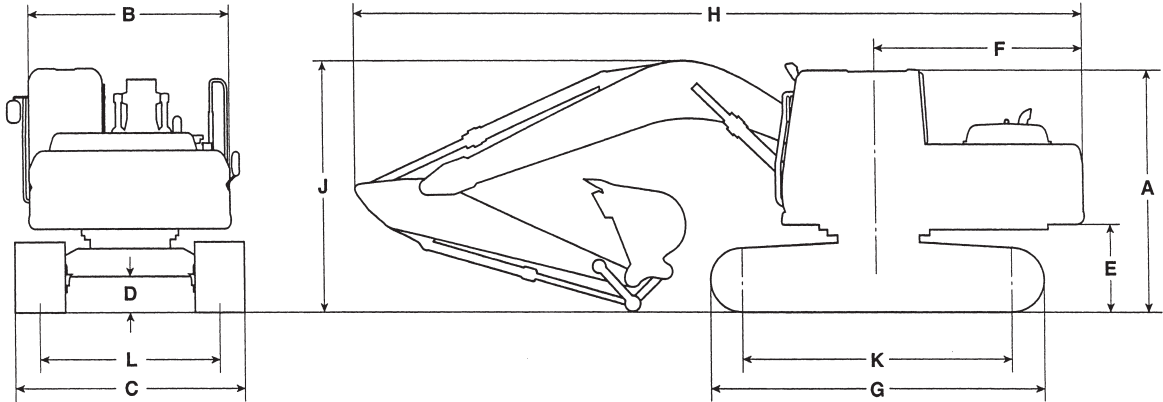

4

**Japan/U.S. Sourced**

	328D LCR Reach		329D Reach		329D Mass		329D L Reach		329D L Mass	
	mm	ft	mm	ft	mm	ft	mm	ft	mm	ft
<b>A</b>	3190	10'0"	3040	10'0"	3040	10'0"	3040	10'0"	3040	10'0"
<b>B</b>	3100	10'2"	2900	9'6"	2900	9'6"	2900	9'6"	2900	9'6"
<b>C</b>	3440	11'3"	2990	9'10"	2990	9'10"	3390	11'1"	3390	11'1"
<b>D</b>	510	1'8"	490	1'7"	490	1'7"	490	1'7"	490	1'7"
<b>E</b>	1200	3'11"	1110	3'8"	1110	3'8"	1110	3'8"	1110	3'8"
<b>F</b>	1900	6'3"	3080	10'1"	3080	10'1"	3080	10'1"	3080	10'1"
<b>G</b>	5020	16'6"	4360	14'4"	4360	14'4"	4860	15'11"	4860	15'11"
<b>H*</b>	9820	32'3"	10 410	34'2"	9860	32'4"	10 410	34'2"	9860	32'4"
<b>J*</b>	3400	11'2"	3130	10'3"	3250	10'8"	3180	10'5"	3250	10'8"
<b>K</b>	4040	13'3"	3490	11'5"	3490	11'5"	3990	13'1"	3990	13'1"
<b>L</b>	2590	8'6"	2390	7'10"	2390	7'10"	2590	8'6"	2590	8'6"

**Belgium Sourced**

	329D L Reach		329D L Mass		329D L VA		329D LN Reach		329D LN Mass		329D LN VA	
	mm	ft	mm	ft	mm	ft	mm	ft	mm	ft	mm	ft
<b>A</b>	3040	10'0"	3040	10'0"	3040	10'0"	3040	10'0"	3040	10'0"	3040	10'0"
<b>B</b>	2900	9'6"	2900	9'6"	2900	9'6"	2900	9'6"	2900	9'6"	2900	9'6"
<b>C</b>	3390	11'1"	3390	11'1"	3390	11'1"	2990	9'10"	2990	9'10"	2990	9'10"
<b>D</b>	480	1'7"	480	1'7"	480	1'7"	480	1'7"	480	1'7"	480	1'7"
<b>E</b>	1110	3'8"	1110	3'8"	1110	3'8"	1110	3'8"	1110	3'8"	1110	3'8"
<b>F</b>	3080	10'1"	3080	10'1"	3080	10'1"	3080	10'1"	3080	10'1"	3080	10'1"
<b>G</b>	4860	15'11"	4860	15'11"	4860	15'11"	4860	15'11"	4860	15'11"	4860	15'11"
<b>H*</b>	10 410	34'2"	9860	32'4"	10 620	34'10"	10 410	34'2"	9860	32'4"	10 620	34'10"
<b>J*</b>	3180	10'5"	3250	10'8"	3370	11'1"	3180	10'5"	3250	10'8"	3370	11'1"
<b>K</b>	3990	13'1"	3990	13'1"	3990	13'1"	3990	13'1"	3990	13'1"	3990	13'1"
<b>L</b>	2590	8'6"	2590	8'6"	2590	8'6"	2390	7'10"	2390	7'10"	2390	7'10"

\*Varies with stick length.

# Excavators

## Shipping Dimensions

- 336D, 336D L — Japan/U.S./Brazil Sourced
- 336D L, 336D LN — Belgium Sourced

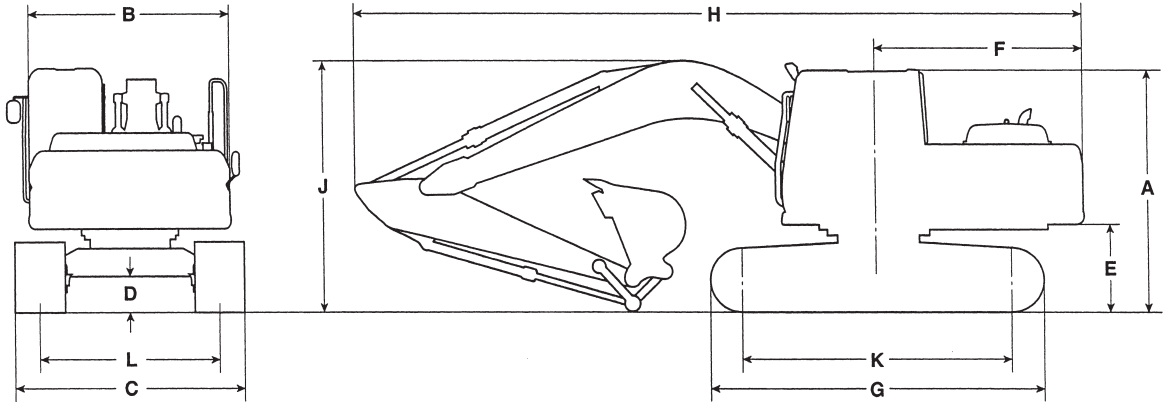

### Japan/U.S./Brazil Sourced

	336D Reach**		336D Mass**		336D L Reach		336D L Mass	
	mm	ft	mm	ft	mm	ft	mm	ft
<b>A</b>	3140	10'4"	3140	10'4"	3140	10'4"	3140	10'4"
<b>B</b>	2960	9'9"	2960	9'9"	2960	9'9"	2960	9'9"
<b>C</b>	3190	10'6"	3190	10'6"	3390	11'1"	3390	11'1"
<b>D</b>	450	1'6"	450	1'6"	450	1'6"	450	1'6"
<b>E</b>	1220	4'0"	1220	4'0"	1220	4'0"	1220	4'0"
<b>F</b>	3500	11'6"	3500	11'6"	3500	11'6"	3500	11'6"
<b>G</b>	4590	15'1"	4590	15'1"	5020	16'6"	5020	16'6"
<b>H*</b>	11 200	36'9"	10 910	35'10"	11 200	36'9"	10 910	35'10"
<b>J*</b>	3700	12'2"	3650	12'0"	3630	11'11"	3580	11'9"
<b>K</b>	2590	8'6"	2590	8'6"	4040	13'3"	4040	13'3"
<b>L</b>	2590	8'6"	2590	8'6"	2590	8'6"	2590	8'6"

\*Varies with stick length.

\*\*600 mm (24") shoes.

### Belgium Sourced

	336D L Reach		336D L Mass		336D L VA		336D LN Reach		336D LN Mass		336D LN VA	
	mm	ft	mm	ft	mm	ft	mm	ft	mm	ft	mm	ft
<b>A</b>	3140	10'4"	3140	10'4"	3140	10'4"	3140	10'4"	3140	10'4"	3140	10'4"
<b>B</b>	2960	9'9"	2960	9'9"	2960	9'9"	2960	9'9"	2960	9'9"	2960	9'9"
<b>C</b>	3290	10'9"	3290	10'9"	3290	10'9"	2990	9'10"	2990	9'10"	2990	9'10"
<b>D</b>	450	1'6"	450	1'6"	450	1'6"	450	1'6"	450	1'6"	450	1'6"
<b>E</b>	1220	4'0"	1220	4'0"	1220	4'0"	1220	4'0"	1220	4'0"	1220	4'0"
<b>F</b>	3500	11'6"	3500	11'6"	3500	11'6"	3500	11'6"	3500	11'6"	3500	11'6"
<b>G</b>	5020	16'6"	5020	16'6"	5020	16'6"	5020	16'6"	5020	16'6"	5020	16'6"
<b>H*</b>	11 200	36'9"	10 910	35'10"	11 230	40'1"	11 200	36'9"	10 910	35'10"	11 230	36'10"
<b>J*</b>	3540	11'7"	3580	11'9"	3630	11'11"	3540	11'7"	3580	11'9"	3630	11'11"
<b>K</b>	4040	13'3"	4040	13'3"	4040	13'3"	4040	13'3"	4040	13'3"	4040	13'3"
<b>L</b>	2590	8'6"	2590	8'6"	2590	8'6"	2390	7'10"	2390	7'10"	2390	7'10"

\*Varies with stick length.

Shipping Dimensions  
 ● 345D L — Japan Sourced  
 ● 345D L, 365C L — Belgium Sourced

Excavators

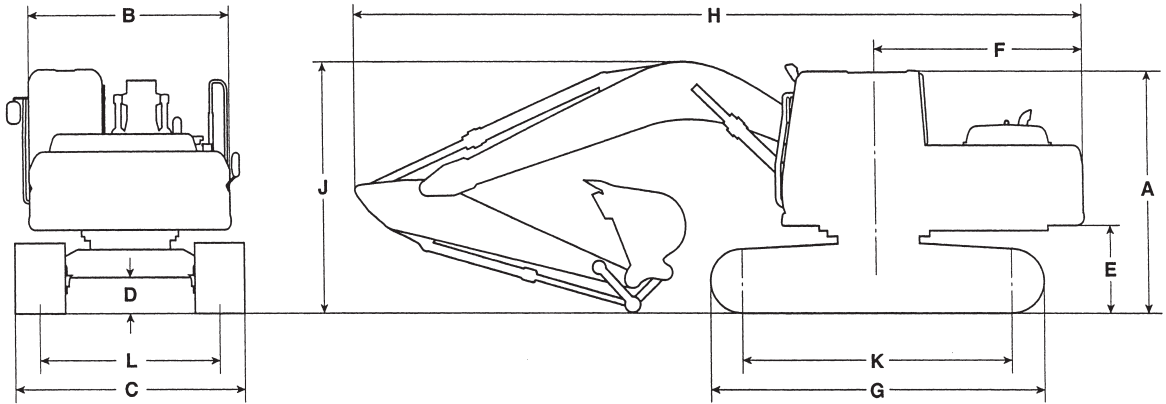

345D L – FIX  
Reach

345D L – FIX  
Mass

345D L – VG  
Reach

	mm	ft	mm	ft	mm	ft
A***	3210	10'6"	3210	10'6"	3360	11'0"
B****	2692	9'8"	2962	9'8"	—	—
C**	3640	11'11"	3640	11'11"	3290	10'9"
D	510	1'8"	510	1'8"	710	2'4"
E	1320	4'4"	1320	4'4"	1430	4'8"
F	3770	12'4"	3770	12'4"	3770	12'4"
G	5360	17'7"	5360	17'7"	5330	17'6"
H*	11 950	39'2"	11 710	37'11"	11 840	38'10"
J*	3660	12'0"	3960	13'0"	3730	12'3"
K	—	—	—	—	4340	14'3"
L	—	—	—	—	2390	7'10"

\*Varies with stick length.

\*\*Transport position — 900 mm (36") track shoes.

\*\*\*Without Falling Object Guard (FOG).

\*\*\*\*No mirror or handrail.

Medium stick is available all models.  
Undercarriage is retracted.

345D L – VG  
Mass

345D L – FG  
Reach

345D L – FG  
Mass

365C L  
Reach

365C L  
6.6 m (21'8")  
Mass  
Boom

365C L  
7.0 m (23'0")  
Mass  
Boom

	mm	ft	mm	ft	mm	ft	mm	ft	mm	ft	mm	ft
A**	3360	11'0"	3310	10'10"	3310	10'10"	3680	12'1"	3680	12'1"	3680	12'1"
B***	—	—	2995	9'10"	2995	9'10"	3450	11'4"	3450	11'4"	3450	11'4"
C	3290	10'9"	3340	10'11"	3340	10'11"	3500	11'6"	3500	11'6"	3500	11'6"
D	710	2'4"	476	1'7"	476	1'7"	840	2'9"	840	2'9"	840	2'9"
E	1430	4'8"	—	—	—	—	1540	5'1"	1540	5'1"	1540	5'1"
F	3770	12'4"	3765	12'4"	3765	12'4"	4015	13'2"	4015	13'2"	4015	13'2"
G	5330	17'6"	5371	17'7"	5371	17'7"	5860	19'3"	5860	19'3"	5860	19'3"
H*	11 610	38'1"	11 824	38'10"	11 530	37'10"	13 307	43'8"	12 199	40'0"	12 615	41'5"
J*	4000	13'1"	3547	11'8"	3938	12'11"	4173	13'8"	4630	15'2"	4634	15'2"
K	4340	14'3"	4356	14'3"	4356	14'3"	4705	15'5"	4705	15'5"	4705	15'5"
L	2390	7'10"	2740	9'0"	2740	9'0"	2750	9'0"	2750	9'0"	2750	9'0"

\*Varies with stick length.

\*\*Without Falling Object Guard (FOG).

\*\*\*No mirror or handrail.



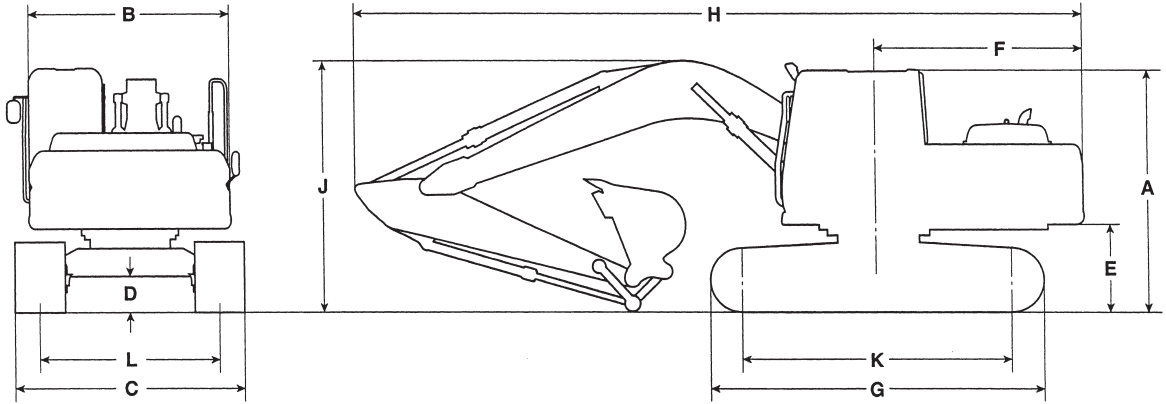

	385C Reach		385C GP		385C Mass		385C L Reach		385C L GP		385C L Mass	
	mm	ft	mm	ft	mm	ft	mm	ft	mm	ft	mm	ft
<b>A*</b>	3760	12'3"	3760	12'3"	3760	12'3"	3760	12'3"	3760	12'3"	3760	12'3"
<b>B**</b>	3470	11'4"	3470	11'4"	3470	11'4"	3470	11'4"	3470	11'4"	3470	11'4"
<b>C</b>	3400	11'2"	3400	11'2"	3400	11'2"	3500	11'2"	3500	11'2"	3500	11'2"
<b>D</b>	890	2'11"	890	2'11"	890	2'11"	890	2'11"	890	2'11"	890	2'11"
<b>E</b>	1580	5'2"	1580	5'2"	1580	5'2"	1580	5'2"	1580	5'2"	1580	5'2"
<b>F</b>	4590	15'1"	4590	15'1"	4590	15'1"	4590	15'1"	4590	15'1"	4590	15'1"
<b>G</b>	5840	19'2"	5840	19'2"	5840	19'2"	6360	19'2"	6360	19'2"	6360	19'2"
<b>H</b>	16 233	53'2"	14 633	48'0"	13 470	44'2"	16 233	53'2"	14 633	48'0"	13 470	44'2"
<b>J</b>	4937	16'2"	4960	16'3"	4782	15'7"	4937	16'2"	4960	16'3"	4782	15'7"
<b>K</b>	4600	15'1"	4600	15'1"	4600	15'1"	5120	15'1"	5120	15'1"	5120	15'1"
<b>L</b>	2750	9'0"	2750	9'0"	2750	9'0"	2750	9'0"	2750	9'0"	2750	9'0"

\*Without Falling Object Guard (FOG).

\*\*No mirror or handrail.

Medium stick is available all models.

Major Component Weights  
 ● 301.6C ● 301.8C ● 302.5C ● 303C CR  
 ● 303.5C CR ● 304C CR ● 305C CR ● 305.5

**Excavators**

	301.6C		301.8C		302.5C		303C CR	
<b>Buckets: (see data in bucket section)</b>	kg	lb	kg	lb	kg	lb	kg	lb
<b>Sticks:*</b>								
Medium Stick		—	54	119	90	198	58	130
Long Stick	59	130	59	130	102	225	77	170
<b>Booms:**</b>								
One-piece	105	231	105	231	179	395	285	630
<b>Other:</b>								
Upperstructure (complete w/o ctwt)	802	1768	805	1775	1160 †	2557	1057	2330
Standard undercarriage (std shoe)	443	977	549	1210	900	1984	1046	2310
Counterweight	125	276	100	220	118	260	360	790
Extra Counterweight		—		—		—	210	460

\*Stick weights include stick, stick lines, bucket cylinder, bucket cylinder pins and bucket linkage.

\*\*Boom weights include boom, boom lines, boom cylinders and rod end pins, stick cylinder, head end pin and stick lines.

†Includes canopy, does not include boom, stick, counterweight or work tool. Undercarriage includes blade, blade cylinder and lines, track motors, swivel joint and lines, swinger sprocket, idlers, rollers and rubber track.

	303.5C CR		304C CR		305C CR		305.5†	
<b>Buckets: (see data in bucket section)</b>	kg	lb	kg	lb	kg	lb	kg	lb
<b>Sticks:*</b>								
Medium Stick	95	210	142	310	145	320	132	292
Long Stick	127	280	187	410	189	420		—
<b>Booms:**</b>								
One-piece	195	430	279	610	280	620	284	627
<b>Other:</b>								
Upperstructure (complete w/o ctwt)	1342	2970	1743	3840	1867	4120	2548	5617
Standard undercarriage (std shoe)	1059	2330	1565	3450	1704	3760	1968	4340
Counterweight	360	790	379	840	603	1330	500	1102
Extra Counterweight	220	490	190	420	190	420		—

\*Stick weights include stick, stick lines, bucket cylinder, bucket cylinder pins and bucket linkage.

\*\*Boom weights include boom, boom lines, boom cylinders and rod end pins, stick cylinder, head end pin and stick lines.

†China and Korea only.

## Excavators

### Major Component Weights

- 307D ● 308D CR ● 308D CR SB ● 311D LRR
- 312D ● 312D L ● 313C CR ● 313C SR

	307D		308D CR		308D CR SB		311D LRR	
Source	Japan		Japan		Japan		Japan	
Buckets: (see data in bucket section)	kg	lb	kg	lb	kg	lb	kg	lb
<b>Sticks:*</b>								
Medium Stick	272	598	285	627	285	627	341	752
Intermediate Stick	—	—	—	—	—	—	383	845
Long Stick	336	739	343	755	343	755	415	915
<b>Booms:**</b>								
One-piece	516	1135	539	1186	507	1115	759	1674
<b>Other:</b>								
Upperstructure (complete w/o ctwt)	2400	5280	2770	6094	3480	7656	3750	8269
Standard undercarriage (std shoe)	2590	5698	2780	6116	2780	6116	—	—
Long undercarriage (std shoe)	—	—	—	—	—	—	4016	8855
Counterweight	750	1650	1050	2310	880	1936	2450	5410

\*Stick weights include stick, stick lines, bucket cylinder, bucket cylinder pins and bucket linkage.

\*\*Boom weights include boom, boom lines, boom cylinders and rod end pins, stick cylinder, head end pin and stick lines.

	312D		312D L		312D/312D L		313C CR		313C SR	
Source	Japan		Japan		France		Japan		Japan	
Buckets: (see data in bucket section)	kg	lb	kg	lb	kg	lb	kg	lb	kg	lb
<b>Sticks:*</b>										
Short Stick	—	—	—	—	581	1281	—	—	—	—
Medium Stick	373	822	373	822	567	1250	380	840	340	750
Intermediate Stick	431	950	431	950	—	—	—	—	—	—
Long Stick	453	999	453	999	645	1422	460	1010	—	—
Heavy Duty Medium Stick	—	—	—	—	—	—	440	970	—	—
<b>Booms:**</b>										
One-piece Reach	825	1819	825	1819	1290	2844	870	1920	—	—
Parallel-Offset	—	—	—	—	—	—	—	—	1590	3510
VA (France sourced only)	—	—	—	—	1806	3982	—	—	—	—
<b>Other:</b>										
Upperstructure (complete w/o ctwt)	3948	8705	3948	8705	4240	9349	3950	8710	4020	8860
Standard undercarriage (std shoe)	4100	9041	—	—	4307	9497	3900	8600	4680	10,320
Long undercarriage (std shoe)	—	—	4400	9702	4617	10,180	—	—	—	—
Counterweight	2450	5410	2450	5410	2450	5402	2500	5510	2500	5510

\*Stick weights include stick, stick lines, bucket cylinder, bucket cylinder pins, bucket linkage and stick nose pin.

\*\*Boom weights include boom, boom lines, boom cylinders and rod end pins, stick cylinder, head end pin and stick lines.

Major Component Weights

- 314D CR
- 314D LCR
- 315D L
- 319D L
- 319D LN

**Excavators**

4

Source	314D CR		314D LCR		315D L	
	Japan		Japan		Japan	
<b>Buckets:</b> (see data in bucket section)	kg	lb	kg	lb	kg	lb
<b>Sticks:*</b>						
Short Stick		—		—	485	1069
Medium Stick	373	822	373	822	520	1146
Intermediate Stick	431	950	431	950	582	1283
Long Stick	453	999	453	999	610	1345
<b>Booms:**</b>						
One-piece	827	1824	827	1824	1628	3590
<b>Other:</b>						
Upperstructure (complete w/o ctwt)	4075	8985	4075	8985	4978	10,976
Standard undercarriage (std shoe)	4025	8875		—		—
Long undercarriage (std shoe)		—	4146	9142	6084	13,415
Counterweight (std)	3300	7280	3300	7280	3179	7010
Counterweight (optional)	3830	8450	3830	8450		—

\*Stick weights include stick, stick lines, bucket cylinder, bucket cylinder pins, bucket linkage and stick nose pin.

\*\*Boom weights include boom, boom lines, boom cylinders and rod end pins, stick cylinder and head end pin.

Source	319D L		319D LN	
	France		France	
<b>Buckets:</b> (see data in bucket section)	kg	lb	kg	lb
<b>Sticks:*</b>				
Short Stick	1002	2209	1002	2209
Medium Stick	981	2163	981	2163
Long Stick	980	2161	980	2161
Extra Long Stick	1075	2370	1075	2370
<b>Booms:**</b>				
One-piece Reach	1878	4140	1878	4140
VA (France sourced only)	2379	5245	2379	5245
<b>Other:</b>				
Upperstructure (complete w/o ctwt)	5484	12,092	5484	12,092
Long undercarriage (std shoe)	7156	15,779	6861	15,129
Counterweight	3600	7938	3600	7938

\*Stick weights include stick, stick lines, bucket cylinder, bucket cylinder pins, bucket linkage and stick nose pin.

\*\*Boom weights include boom, boom lines, boom cylinders and rod end pins, stick cylinder and head end pin.

# Excavators

## Major Component Weights

● M313D ● M315D ● M316D ● M318D ● M322D

	M313D		M315D		M316D		M318D		M322D	
<b>Buckets: (see data in bucket section)</b>	kg	lb	kg	lb	kg	lb	kg	lb	kg	lb
<b>Sticks:*</b>										
Short Stick	370	<b>816</b>	470	<b>1036</b>	470	<b>1036</b>	550	<b>1213</b>	650	<b>1433</b>
Medium Stick	390	<b>860</b>	514	<b>1133</b>	514	<b>1133</b>	580	<b>1279</b>	700	<b>1544</b>
Long Stick	440	<b>970</b>	530	<b>1169</b>	530	<b>1169</b>	600	<b>1323</b>	780	<b>1720</b>
<b>Booms:**</b>										
VA Boom	1695	<b>3737</b>	2020	<b>4454</b>	2050	<b>4520</b>	2230	<b>4917</b>	2830	<b>6240</b>
One-piece Boom	1250	<b>2756</b>	1530	<b>3374</b>	1560	<b>3440</b>	1930	<b>4256</b>	2350	<b>5182</b>
<b>Other:</b>										
Upperstructure (with swing bearing, no boom)	7065	<b>15,578</b>	8126	<b>17,918</b>	9296	<b>20,498</b>	10 050	<b>22,160</b>	10 245	<b>22,590</b>
Undercarriage (with standard tires)	3500	<b>7718</b>	3890	<b>8577</b>	4200	<b>9261</b>	4200	<b>9261</b>	4900	<b>10,805</b>
Dozer Blade front	750	<b>1654</b>	750	<b>1654</b>	740	<b>1632</b>	740	<b>1632</b>	—	
Dozer Blade rear	650	<b>1433</b>	650	<b>1433</b>	770	<b>1698</b>	770	<b>1698</b>	920	<b>2029</b>
Outriggers front	960	<b>2117</b>	960	<b>2117</b>	1030	<b>2271</b>	1030	<b>2271</b>	1260	<b>2778</b>
Outriggers rear	950	<b>2095</b>	950	<b>2095</b>	1010	<b>2227</b>	1010	<b>2227</b>	1220	<b>2690</b>

\*Stick weight includes stick, stick lines, bucket cylinder, bucket cylinder pins, bucket linkage and bucket linkage pins.

\*\*Boom weight includes boom, boom lines, boom cylinders, boom cylinder rod end pin, stick cylinder, stick cylinder head end pin and boom nose pin.

Source	320D		320D RR	
	Japan/Brazil		Japan/U.S.	
<b>Buckets:</b> (see data in bucket section)	kg	lb	kg	lb
<b>Booms:**</b>				
One-piece Reach	1400	3090	1400	3090
One-piece Reach HD	2194	4840	—	—
<b>Sticks:* (for Reach Boom)</b>				
Short Stick	730	1610	—	—
Medium Stick	640	1410	640	1410
Long Stick	660	1460	660	1460
Extra Long Stick	910	2010	910	2010
Heavy Duty Long Stick	1100	2430	—	—
Heavy Duty Medium Stick	1040	2290	—	—
<b>Booms:**</b>				
One-piece Mass	1410	3110	—	—
<b>Sticks:* (for Mass Boom)</b>				
Short Stick	720	1590	—	—
Medium Stick	750	1650	—	—
Upperstructure (complete w/o ctwt)	5750	12,677	5650	12,457
Undercarriage — Standard				
	6650	(600 mm/24 in) 14,660	6650	(600 mm/24 in) 14,660
	7000	(700 mm/28 in) 15,430	7000	(700 mm/28 in) 15,430
	7250	(800 mm/32 in) 15,980	7250	(800 mm/32 in) 15,980
( ) Shoe width — Long (FIX)	7200	(600 mm/24 in) 15,870	7200	(600 mm/24 in) 15,870
	7580	(700 mm/28 in) 16,710	7580	(700 mm/28 in) 16,710
	7850	(800 mm/32 in) 17,310	7850	(800 mm/32 in) 17,310
	8120	(900 mm/36 in) 17,900	8120	(900 mm/36 in) 17,900
Counterweight — Standard	3860	8510	6500	14,330

\*Stick weights include stick and stick lines.

\*\*Boom weights include boom, boom lines, boom cylinders and rod end pins, stick cylinder and head end pin.

# Excavators

## Major Component Weights

- 321D LCR ● 323D ● 323D L
- 324D ● 324D L ● 324D LN

Source	321D LCR		323D		323D L		324D		324D L/ 324D LN		
	Japan		Belgium/Brazil France/Japan		China		Japan/U.S.		Belgium		
Buckets: (see data in bucket section)	kg	lb	kg	lb	kg	lb	kg	lb	kg	lb	
<b>Booms:**</b>											
One-piece Reach	2106	4640	1680	3704	1680	3704	2033	4482	2033	4482	
VA Boom	2210	4873	2240	4939	—	—	—	—	—	—	
<b>Sticks:* (for Reach Boom)</b>											
Short Stick	—	—	1210	2668	—	—	1149	2533	1149	2533	
Medium Stick	—	—	1100	2426	1100	2426	1208	2663	1208	2663	
Long Stick	926	2040	1120	2470	1120	2470	1199	2643	—	—	
Extra Long Stick	—	—	—	—	—	—	1610	3549	—	—	
<b>Booms:**</b>											
One-piece Mass	—	—	1120	2470	1700	3749	2138	4713	2138	4713	
•	—	—	—	—	—	—	—	—	2643	5166	
<b>Sticks:* (for Mass Boom)</b>											
Short Stick	—	—	1210	2668	1210	2668	1470	3241	1470	3241	
Medium Stick	—	—	—	—	—	—	—	—	1535	3385	
Upperstructure (complete w/o ctwt)	10 233	22,564	7450	16,427	—	—	6980	15,388	6980	15,388	
Undercarriage — Standard	(600 mm/24 in)	6649	14,660	(600 mm/24 in)	7080	15,611	—	—	(600 mm/24 in)	7950	17,527
	—	—	—	—	—	—	—	—	(700 mm/28 in)	8210	18,100
	—	—	—	—	—	—	—	—	(800 mm/32 in)	8485	18,706
( ) Shoe width — Long (FIX)	(600 mm/24 in)	7847	17,300	—	—	—	—	—	(600 mm/24 in)	8661	19,094
	—	—	—	—	—	—	—	—	(700 mm/28 in)	8943	19,716
	—	—	—	—	—	—	—	—	(800 mm/32 in)	9240	20,370
Undercarriage — L	—	—	7930	17,486	7930	17,486	—	—	8485	18,706	
— LN	—	—	7580	16,714	—	—	—	—	7950	17,527	
— SA	—	—	8376	18,469	—	—	—	—	—	—	
Counterweight — Standard	6100	13,450	4400	9702	4400	9702	4520	9965	—	—	
— L	—	—	4400	9702	—	—	—	—	4520	9965	
— LN	—	—	4700	10,364	—	—	—	—	4520	9965	
— SA	—	—	4700	10,364	—	—	—	—	—	—	

\*Stick weights include stick and stick lines.

\*\*Boom weights include boom, boom lines, boom cylinders and rod end pins, stick cylinder and head end pin.

Source	328D LCR		329D/ 329D L		329D L/ 329D LN		336D/ 336D L		336D L/ 336D LN	
	Japan/U.S.		Japan/U.S.		Belgium		Japan/U.S. Brazil		Belgium	
Buckets: (see data in bucket section)	kg	lb	kg	lb	kg	lb	kg	lb	kg	lb
<b>Booms:**</b>										
One-piece Reach HD	2300	5071	2300	5071	2300	5071	3495	7706	3255	7176
<b>Sticks:* (for Reach Boom)</b>										
Short Stick	1300	2866	1300	2866	1300	2866	1890	4170	1867	4116
•	1390	3064	1390	3064	—	—	2012	4436	—	—
•	—	—	1580	3483	—	—	—	—	—	—
•	—	—	1610	3549	—	—	—	—	—	—
Medium Stick	—	—	—	—	1390	3064	—	—	2012	4436
Long Stick	—	—	—	—	1580	3583	—	—	2180	4807
Long HD Stick	—	—	—	—	1610	3549	—	—	2305	5083
<b>Booms:**</b>										
One-piece Mass	—	—	2375	5236	2375	5236	3283	7238	3283	7238
VA Boom	—	—	—	—	3195	7045	—	—	4433	9775
<b>Sticks:* (for Mass Boom)</b>										
Short	—	—	—	—	—	—	—	—	2079	4583
Medium	—	—	—	—	1530	3373	—	—	—	—
<b>Sticks:* (for Mass Boom &amp; VA Boom)</b>										
Short	—	—	1470	3241	—	—	2079	4583	—	—
•	—	—	1530	3373	—	—	—	—	—	—
Upperstructure (complete w/o ctwt)	7720	17,020	6770	14,925	6770	14,925	8160	17,990	8160	17,990
Undercarriage — Standard	—	—	(600 mm/24 in)	—	—	—	(600 mm/24 in)	—	—	—
	—	—	9440	20,812	—	—	11 980	26,411	—	—
	—	—	(700 mm/28 in)	—	—	—	(700 mm/28 in)	—	—	—
	—	—	9742	21,478	—	—	12 278	27,068	—	—
	—	—	(800 mm/32 in)	—	—	—	(800 mm/32 in)	—	—	—
	—	—	10 312	22,734	—	—	12 906	28,453	—	—
( ) Shoe width — Long (FIX)	(600 mm/24 in)	(600 mm/24 in)	—	—	—	—	(600 mm/24 in)	—	—	—
	12 689	27,975	10 432	22,999	—	—	12 884	28,404	—	—
	(700 mm/28 in)	(700 mm/28 in)	—	—	—	—	(700 mm/28 in)	—	—	—
	13 014	28,691	10 767	23,737	—	—	13 210	29,123	—	—
	(850 mm/34 in)	(800 mm/32 in)	—	—	—	—	(800 mm/32 in)	—	—	—
	14 000	30,865	11 400	25,133	—	—	13 894	30,631	—	—
Undercarriage — L	—	—	—	—	10 312	22,734	—	—	12 278	27,068
— LN	—	—	—	—	9440	20,812	—	—	11 980	26,411
— ES	—	—	—	—	—	—	—	—	15 020	33,119
Counterweight — Standard	7720	17,020	5410	11,927	—	—	6020	13,272	—	—
— L	—	—	—	—	5410	11,927	—	—	6260	13,803
— LN	—	—	—	—	5410	11,927	—	—	6260	13,803

\*Stick weights include stick and stick lines.

\*\*Boom weights include boom, boom lines, boom cylinders and rod end pins, stick cylinder and head end pin.



	345D/345D L		345D L		365C L		385C/385C L	
Source	Japan/U.S.		Belgium		Belgium		Belgium	
Buckets: (see data in bucket section)	kg	lb	kg	lb	kg	lb	kg	lb
<b>Booms:*</b>								
One-piece Reach	—		—		6400	<b>14,110</b>	9650	<b>21,280</b>
One-piece Long Reach	5135	<b>11,323</b>	—		—		—	
One-piece Reach HD	5467	<b>12,052</b>	4590	<b>10,120</b>	—		—	
<b>Sticks:** (for Reach Boom)</b>								
Short Stick	1670	<b>3680</b>	1950	<b>4300</b>	3370	<b>7430</b>	—	
•	1690	<b>3730</b>	—		3580	<b>7890</b>	—	
•	1805	<b>3980</b>	—		3800	<b>8380</b>	4550	<b>10,030</b>
•	1935	<b>4267</b>	—		—		—	
Medium Stick	—		1990	<b>4390</b>	—		—	
Long Stick	—		—		3980	<b>8780</b>	4860	<b>10,720</b>
<b>Booms:*</b>								
One-piece General Purpose	—		—		8240	<b>18,170</b>	—	
<b>Sticks:** (for General Purpose Boom)</b>								
Short	—		—		—		4820	<b>10,630</b>
•	—		—		—		4550	<b>10,030</b>
Long	—		—		—		4860	<b>10,720</b>
<b>Booms:*</b>								
One-piece Mass	5474	<b>12,068</b>	4600	<b>10,145</b>	6420 †	<b>14,160</b>	8320	<b>18,350</b>
•	—		—		6720 ‡	<b>14,820</b>	—	
<b>Sticks:** (for Mass Boom)</b>								
Short	—		—		4050	<b>8930</b>	4850	<b>10,690</b>
•	—		—		4230	<b>9330</b>	4990	<b>11,000</b>
Medium	—		2190	<b>4830</b>	—		—	
Long	—		2370	<b>5225</b>	—		—	
<b>Sticks:** (for Mass Boom &amp; VA Boom)</b>								
Short	1765	<b>3890</b>	—		—		—	
Extra Long	1945	<b>4290</b>	—		—		—	
Upperstructure (complete w/o cwt)	10 800	<b>23,810</b>	12 440	<b>27,430</b>	17 380	<b>38,320</b>	21 450	<b>47,300</b>
Undercarriage — Standard	(750 mm/30 in) 15 950	<b>35,160</b>	—		—		(650 mm/26 in) 32 160	<b>70,910</b>
( ) Shoe width — Long	—		—		(750 mm/30 in) 26 970	<b>59,470</b>	(750 mm/30 in) 32 900	<b>72,540</b>
( ) Shoe width — Long (FIX)	(750 mm/30 in) 16 560	<b>36,510</b>	—		—		—	
— Long (VG)	(600 mm/24 in) 17 840	<b>39,330</b>	—		—		—	
( ) Shoe width — ES	—		—		(650 mm/26 in) 32 340	<b>71,310</b>	—	
Undercarriage — L VG	—		17 790	<b>39,225</b>	—		—	
Counterweight — Standard	9000	<b>19,845</b>	—		—		11 650	<b>25,690</b>
— Long	—		9040	<b>19,933</b>	10 090	<b>22,250</b>	—	

\*Boom weights include: boom, boom lines, cylinders, rod end pins, stick cylinder and head end pin.

\*\*Stick weights include stick and stick lines.

†6.6 m (21'8").

‡7.0 m (23'0").

NOTE: Heavy duty track shoes available.

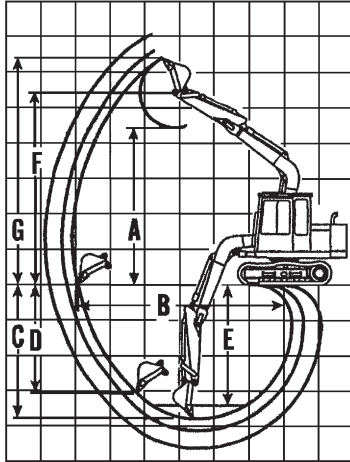

**One-Piece Boom Digging Envelope**

- Standard shoes and undercarriage
- Lug height not included

**KEY:**

- A** Maximum loading height of bucket with teeth
- B** Maximum reach at ground level
- C** Maximum digging depth
- D** Maximum vertical wall
- E** Maximum depth of cut for 2.44 m (8'0") level bottom (straight clean up)
- F** Maximum bucket hinge pin height
- G** Maximum height, to bucket teeth at highest arc

Stick	301.6C				301.8C				302.5C			
	890 mm	2'11"	1.09 m	3'6"	925 mm	3'0"	1.125 m	3'8"	925 mm	3'0"	1.125 m	3'8"
<b>A</b>	2360	7'9"	2480	8'2"	2360	7'9"	2480	8'2"	3110	10'2"	3280	10'9"
<b>B</b>	3610	11'10"	3800	12'6"	3610	11'10"	3800	12'6"	4545	14'11"	4810	15'9"
<b>C</b>	2080	6'10"	2320	7'7"	2080	6'10"	2320	7'7"	2640	8'8"	2930	9'7"
<b>D</b>	1620	5'4"	1810	5'11"	1620	5'4"	1810	5'11"	1920	6'4"	2180	7'2"
<b>E</b>	—	—	—	—	—	—	—	—	—	—	—	—
<b>F</b>	—	—	—	—	—	—	—	—	—	—	—	—
<b>G</b>	3350	11'0"	3460	11'4"	3350	11'0"	3460	11'4"	4335	14'3"	4530	14'10"

# Excavators

## Range Dimensions

- 303C CR    ● 303.5C CR
- 304C CR    ● 305C CR    ● 305.5

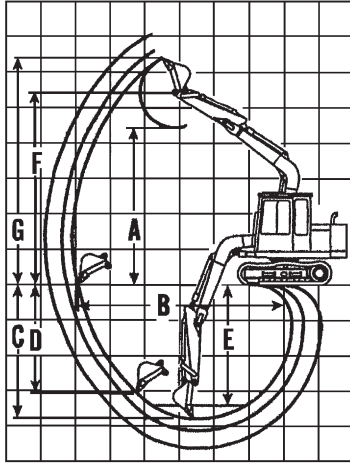

### One-Piece Boom Digging Envelope

- Standard shoes and undercarriage
- Lug height not included

#### KEY:

- A** Maximum loading height of bucket with teeth
- B** Maximum reach at ground level
- C** Maximum digging depth
- D** Maximum vertical wall
- E** Maximum depth of cut for 2.44 m (8'0") level bottom (straight clean up)
- F** Maximum bucket hinge pin height
- G** Maximum height, to bucket teeth at highest arc

#### 303C CR

#### 303.5C CR

Stick	1.26 m		4'2"		1.56 m		5'1"		1.38 m		4'6"		1.78 m		5'10"	
	mm	ft	mm	ft	mm	ft	mm	ft	mm	ft	mm	ft	mm	ft	mm	ft
<b>A</b>	3490	11'5"	3610	11'10"	3570	11'9"	3670	12'0"								
<b>B</b>	5100	16'9"	5350	17'7"	5240	17'2"	5500	18'1"								
<b>C</b>	2910	9'7"	3200	10'6"	3150	10'4"	3450	11'4"								
<b>D</b>	2400	7'10"	2550	8'4"	2490	8'2"	2650	8'8"								
<b>E</b>	—	—	—	—	—	—	—	—								
<b>F</b>	—	—	—	—	—	—	—	—								
<b>G</b>	4950	16'3"	5060	16'7"	5020	16'6"	5110	16'9"								

#### 304C CR

#### 305C CR

#### 305.5\*

Stick	1.62 m		5'4"		2.02 m		6'8"		1.43 m		4'7"		1.83 m		6'0"		1.6 m		5'4"		1.83 m		6'0"	
	mm	ft	mm	ft	mm	ft	mm	ft	mm	ft	mm	ft	m	ft	m	ft	m	ft	m	ft	m	ft		
<b>A</b>	3690	12'1"	3900	12'10"	3800	12'6"	4050	13'3"	3.84	12.6														
<b>B</b>	5460	17'11"	5830	19'2"	5650	18'6"	6050	19'10"	6.04	19.8														
<b>C</b>	3300	10'10"	3690	12'1"	3490	11'5"	3890	12'9"	3.83	12.6														
<b>D</b>	2440	8'0"	2760	9'1"	2530	8'4"	2940	9'8"	3.08	10.1														
<b>E</b>	—	—	—	—	—	—	—	—	3.41	11.2														
<b>F</b>	—	—	—	—	—	—	—	—	4.73	15.5														
<b>G</b>	5280	17'4"	5480	18'0"	5370	17'7"	5630	18'6"	5.58	18.3														

\*China and Korea only.

\*\*Not available at time of printing.

- 307C ● 307D
- 308D CR ● 308D CR SB

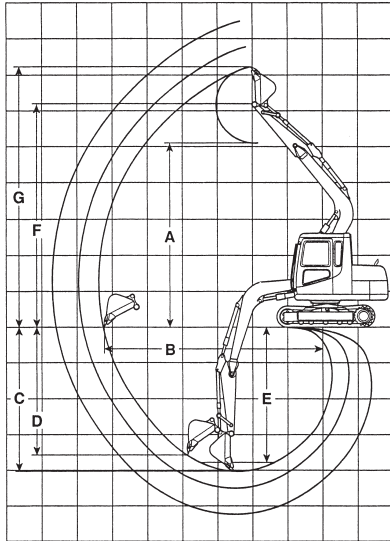

**One-Piece Boom Digging Envelope**

- Standard shoes and undercarriage
- Lug height not included

**KEY:**

- A** Maximum loading height of bucket with teeth
- B** Maximum reach at ground level
- C** Maximum digging depth
- D** Maximum vertical wall
- E** Maximum depth of cut for 2.44 m (8'0") level bottom (straight clean up)
- F** Maximum bucket hinge pin height
- G** Maximum height, to bucket teeth at highest arc

**307C\***

**307D**

Stick	1.67 m		2.21 m		1.67 m		2.21 m	
	m	ft	m	ft	m	ft	m	ft
<b>A</b>	5.15	16'11"	5.56	18'3"	5.21	17'1"	5.61	18'5"
<b>B</b>	6.20	20'4"	6.72	22'1"	6.15	20'2"	6.67	21'11"
<b>C</b>	4.11	13'6"	4.65	15'3"	4.05	13'3"	4.6	15'1"
<b>D</b>	3.67	12'0"	4.19	13'9"	3.64	11'11"	4.17	13'8"
<b>E</b>	3.77	12'4"	4.35	14'3"	—	—	—	—
<b>F</b>	6.24	20'6"	6.65	21'10"	—	—	—	—
<b>G</b>	7.29	23'11"	7.69	25'3"	7.23	23'9"	7.46	25'1"

\*China only.

**308D CR**

**308D CR SB**

Stick	1.67 m		2.21 m		1.67 m		2.21 m	
	m	ft	m	ft	m	ft	m	ft
<b>A</b>	5.31	17'5"	5.73	18'10"	4.64	15'3"	4.98	16'4"
<b>B</b>	6.19	20'4"	6.71	22'0"	6.9	22'8"	7.43	24'5"
<b>C</b>	4.09	13'5"	4.63	15'2"	4.18	13'9"	4.73	15'6"
<b>D</b>	3.65	12'0"	4.16	13'8"	2.99	9'10"	3.58	11'9"
<b>E</b>	—	—	—	—	—	—	—	—
<b>F</b>	—	—	—	—	—	—	—	—
<b>G</b>	7.34	24'1"	7.76	25'6"	6.61	21'8"	6.96	22'10"

# Excavators

## Range Dimensions

- 311D LRR ● 312D ● 312D L — Japan Sourced
- 312D ● 312D L — France Sourced
- 313C SR ● 313C CR — Japan Sourced

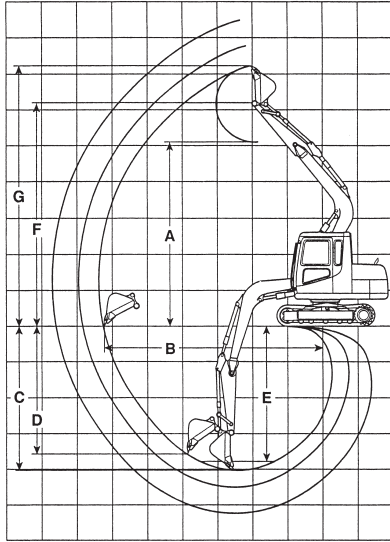

### One-Piece Boom Digging Envelope

- Standard shoes and undercarriage
- Lug height not included

#### KEY:

- A** Maximum loading height of bucket with teeth
- B** Maximum reach at ground level
- C** Maximum digging depth
- D** Maximum vertical wall
- E** Maximum depth of cut for 2.44 m (8'0") level bottom (straight clean up)
- F** Maximum bucket hinge pin height
- G** Maximum height, to bucket teeth at highest arc

### Japan Sourced

#### 311D LRR

#### 312D, 312D L

Stick	2.25 m 7'5"		2.6 m 8'6"		2.8 m 9'2"		2.5 m 8'2"		2.8 m 9'2"		3 m 9'10"	
	m	ft	m	ft	m	ft	m	ft	m	ft	m	ft
<b>A</b>	5.45	17'11"	5.64	18'6"	5.77	18'11"	6.10	20'0"	6.21	20'4"	6.34	20'10"
<b>B</b>	7.70	25'3"	7.90	25'11"	8.10	26'7"	8.17	26'10"	8.43	27'8"	8.62	28'3"
<b>C</b>	5.04	16'6"	5.39	17'8"	5.59	18'4"	5.54	18'2"	5.84	19'2"	6.04	19'10"
<b>D</b>	4.46	14'8"	4.77	15'8"	4.98	16'4"	4.98	16'4"	5.16	16'11"	5.36	17'7"
<b>E</b>	4.81	15'9"	5.19	17'0"	5.40	17'9"	5.33	17'6"	5.64	18'6"	5.85	19'2"
<b>F</b>	6.67	21'11"	6.86	22'6"	6.99	22'11"	7.32	24'0"	7.44	24'5"	7.56	24'10"
<b>G</b>	7.80	25'7"	7.99	26'3"	8.13	26'8"	8.48	27'10"	8.58	28'2"	8.70	28'7"

### France Sourced

#### 312D, 312D L

### Japan Sourced

#### 313C SR\*

#### 313C CR

Stick	2.1 m 6'11"		2.5 m 8'2"		3 m 9'10"		2.13 m 7'0"		2.5 m 8'2"		3 m 9'10"	
	m	ft	m	ft	m	ft	m	ft	m	ft	m	ft
<b>A</b>	6.10	20'0"	6.21	20'5"	6.34	20'10"	6.06	19'11"	6.86	22'6"	7.19	23'7"
<b>B</b>	8.17	26'10"	8.43	27'8"	8.62	28'3"	7.23	23'9"	8.18	26'10"	8.63	28'4"
<b>C</b>	5.54	18'2"	5.84	19'2"	6.04	19'10"	4.84	15'11"	5.45	17'11"	5.95	19'6"
<b>D</b>	4.98	16'4"	5.16	16'11"	5.36	17'7"	3.60	11'10"	4.91	16'1"	5.33	17'6"
<b>E</b>	5.33	17'6"	5.64	18'6"	5.85	19'2"	4.47	14'8"	5.24	17'2"	5.77	18'11"
<b>F</b>	7.06	23'2"	7.32	24'0"	7.56	24'10"	7.47	24'6"	8.10	26'7"	8.43	27'8"
<b>G</b>	8.48	27'10"	8.58	28'1"	8.70	28'7"	8.47	27'9"	9.30	30'6"	9.62	31'7"

\*Parallel-offset.

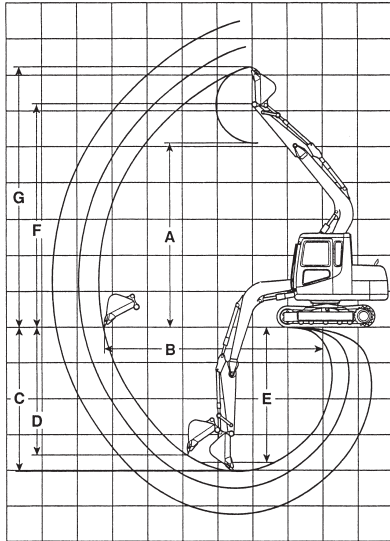

**One-Piece Boom Digging Envelope**

- Standard shoes and undercarriage
- Lug height not included

**KEY:**

- A** Maximum loading height of bucket with teeth
- B** Maximum reach at ground level
- C** Maximum digging depth
- D** Maximum vertical wall
- E** Maximum depth of cut for 2.44 m (8'0") level bottom (straight clean up)
- F** Maximum bucket hinge pin height
- G** Maximum height, to bucket teeth at highest arc

**Japan Sourced**

**314D CR, 314D LCR**

Stick	2.5 m 8'2"		2.8 m 9'2"		3 m 9'10"	
	m	ft	m	ft	m	ft
<b>A</b>	6.87	22'6"	7.04	23'1"	7.20	23'7"
<b>B</b>	8.18	26'10"	8.44	27'8"	8.63	28'4"
<b>C</b>	5.44	17'10"	5.74	18'10"	5.94	19'6"
<b>D</b>	4.91	16'1"	5.08	16'8"	5.28	17'4"
<b>E</b>	5.24	17'2"	5.55	18'3"	5.76	18'11"
<b>F</b>	—	—	—	—	—	—
<b>G</b>	9.30	30'6"	9.47	31'1"	9.63	31'7"

**Japan/France Sourced**

**315D L**

Stick	1.85 m 6'0"		2.25 m 7'4"		2.6 m 8'6"		2.9 m 9'6"		3.1 m 10'2"	
	m	ft	m	ft	m	ft	m	ft	m	ft
<b>A</b>	5.92	19'5"	6.14	20'2"	6.31	20'8"	6.31	20'8"	6.4	21'0"
<b>B</b>	8.05	26'5"	8.43	27'8"	8.75	28'8"	8.96	29'5"	9.15	30'0"
<b>C</b>	5.32	17'5"	5.72	18'9"	6.07	19'11"	6.37	20'11"	6.57	21'7"
<b>D</b>	4.38	14'4"	4.92	16'2"	5.35	17'7"	5.36	17'7"	5.55	18'3"
<b>E</b>	5.03	16'6"	5.47	17'11"	5.84	19'2"	6.13	20'1"	6.34	20'10"
<b>F</b>	7.27	23'10"	7.49	24'7"	7.66	25'2"	7.71	25'4"	7.75	25'5"
<b>G</b>	8.50	27'11"	8.74	28'8"	8.92	29'3"	8.87	29'1"	8.97	29'5"

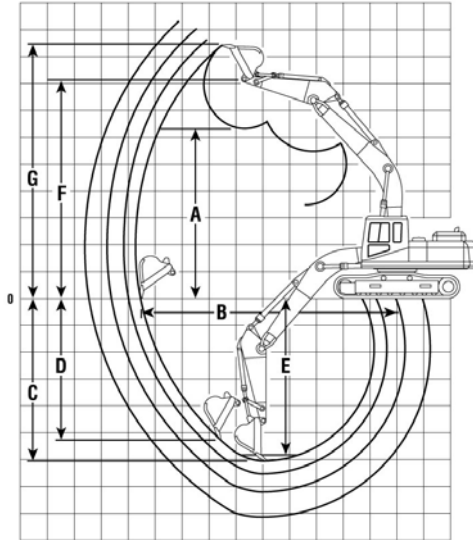

**One-Piece Boom Digging Envelope**

- Standard shoes and undercarriage

**KEY:**

- A** Maximum loading height of bucket with teeth
- B** Maximum reach at ground level
- C** Maximum digging depth
- D** Maximum vertical wall
- E** Maximum depth of cut for 2.44 m (8'0") level bottom (straight clean up)
- F** Maximum bucket hinge pin height
- G** Maximum height, to bucket teeth at highest arc

**France Sourced**

**319D L, 319D LN**

Stick	1.8 m		2.25 m		2.7 m		3.2 m	
	m	ft	m	ft	m	ft	m	ft
<b>A</b>	5.84	19'2"	6.11	20'0"	6.41	21'0"	6.81	22'4"
<b>B</b>	8.41	27'7"	8.86	29'1"	9.30	30'6"	9.82	32'2"
<b>C</b>	5.52	18'1"	5.97	19'7"	6.42	21'1"	6.92	22'8"
<b>D</b>	4.00	13'1"	5.00	16'5"	5.57	18'4"	6.17	20'2"
<b>E</b>	5.21	17'1"	5.72	18'10"	6.21	20'5"	6.75	22'1"
<b>F</b>	7.47	24'6"	7.75	25'5"	8.04	26'5"	8.44	27'8"
<b>G</b>	8.62	28'4"	8.96	29'4"	9.27	30'5"	9.68	31'9"

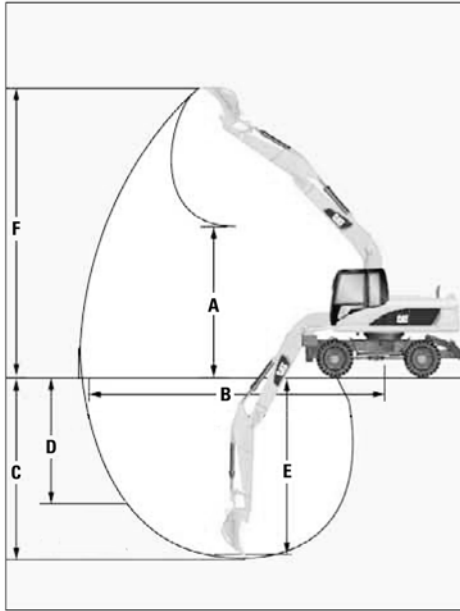

**One-Piece Boom Digging Envelope**

- Standard 10 × 20 tires and undercarriage
- General purpose bucket

**KEY:**

- A** Maximum loading height of bucket with teeth
- B** Maximum reach at ground level
- C** Maximum digging depth
- D** Maximum vertical wall
- E** Maximum depth of cut for 2.5 m (8'2") level bottom (straight clean up)
- F** Maximum height, to bucket teeth at highest arc

**M313D**

Stick	2 m	6'7"	2.3 m	7'7"	2.6 m	8'6"
Bucket	0.715 m <sup>3</sup>	0.94 yd <sup>3</sup>	0.64 m <sup>3</sup>	0.84 yd <sup>3</sup>	0.64 m <sup>3</sup>	0.84 yd <sup>3</sup>
	m	ft	m	ft	m	ft
<b>A</b>	5.91	19'5"	5.97	19'7"	6.14	20'2"
<b>B</b>	8.23	27'0"	8.48	27'10"	8.77	28'10"
<b>C</b>	4.99	16'4"	5.29	17'4"	5.59	18'4"
<b>D</b>	3.41	11'2"	3.37	11'1"	3.67	12'0"
<b>E</b>	4.75	15'7"	5.07	16'8"	5.39	17'8"
<b>F</b>	8.60	28'2"	8.62	28'3"	8.79	28'10"

**M315D**

Stick	2.1 m	6'11"	2.4 m	7'10"	2.6 m	8'6"
Bucket	0.815 m <sup>3</sup>	1.07 yd <sup>3</sup>	0.7 m <sup>3</sup>	0.92 yd <sup>3</sup>	0.7 m <sup>3</sup>	0.92 yd <sup>3</sup>
	m	ft	m	ft	m	ft
<b>A</b>	6.00	19'8"	6.11	20'0"	6.23	20'5"
<b>B</b>	8.71	28'7"	8.97	29'5"	9.17	30'1"
<b>C</b>	5.39	17'8"	5.69	18'8"	5.89	19'4"
<b>D</b>	3.51	11'6"	3.65	12'0"	3.82	12'6"
<b>E</b>	5.17	16'11"	5.49	18'0"	5.70	18'8"
<b>F</b>	8.98	29'5"	9.07	29'9"	9.19	30'2"



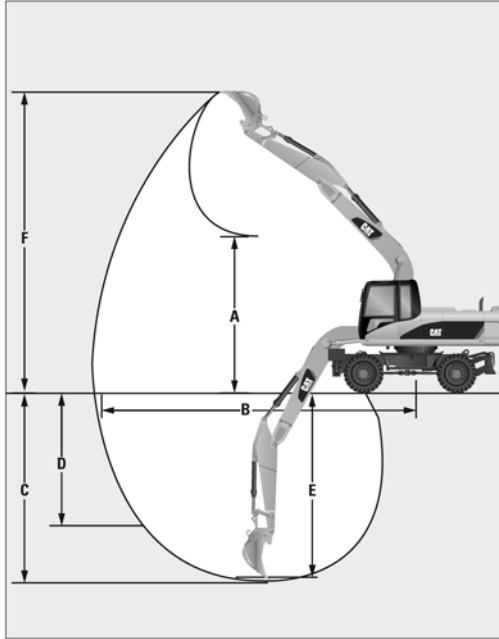

**One-Piece Boom Digging Envelope**

- Standard 10 × 20 tires and undercarriage
- General purpose bucket

**KEY:**

- A** Maximum loading height of bucket with teeth
- B** Maximum reach at ground level
- C** Maximum digging depth
- D** Maximum vertical wall
- E** Maximum depth of cut for 2.5 m (8'2") level bottom (straight clean up)
- F** Maximum height, to bucket teeth at highest arc

**M316D**

**M318D**

Stick	2.1 m	6'11"	2.4 m	7'10"	2.6 m	8'6"	2.2 m	7'3"	2.5 m	8'2"	2.8 m	9'2"
Bucket	0.815 m <sup>3</sup>	1.07 yd <sup>3</sup>	0.815 m <sup>3</sup>	1.07 yd <sup>3</sup>	0.7 m <sup>3</sup>	0.92 yd <sup>3</sup>	0.91 m <sup>3</sup>	1.19 yd <sup>3</sup>	0.91 m <sup>3</sup>	1.19 yd <sup>3</sup>	0.7 m <sup>3</sup>	0.92 yd <sup>3</sup>
	m	ft	m	ft	m	ft	m	ft	m	ft	m	ft
<b>A</b>	6.02	19'9"	6.13	20'1"	6.25	20'6"	5.90	19'4"	6.11	20'0"	6.27	20'7"
<b>B</b>	8.71	28'7"	8.97	29'5"	9.17	30'1"	9.00	29'6"	9.32	30'7"	9.60	31'6"
<b>C</b>	5.37	17'7"	5.67	18'7"	5.87	19'3"	5.70	18'8"	6.00	19'8"	6.30	20'8"
<b>D</b>	3.49	11'5"	3.63	11'11"	3.80	12'6"	2.88	9'5"	3.34	10'11"	3.62	11'10"
<b>E</b>	5.15	16'11"	5.47	17'11"	5.68	18'8"	5.49	18'0"	5.81	19'0"	6.12	20'1"
<b>F</b>	9.00	29'6"	9.09	29'10"	9.21	30'3"	8.76	28'9"	9.01	29'7"	9.17	30'1"

**M322D**

Stick	2.2 m	7'3"	2.5 m	8'2"	2.9 m	9'6"
Bucket	1.04 m <sup>3</sup>	1.36 yd <sup>3</sup>	0.805 m <sup>3</sup>	1.05 yd <sup>3</sup>	0.805 m <sup>3</sup>	1.05 yd <sup>3</sup>
	m	ft	m	ft	m	ft
<b>A</b>	6.30	20'8"	6.23	20'5"	6.45	21'2"
<b>B</b>	9.72	31'11"	9.93	32'7"	10.32	33'10"
<b>C</b>	5.77	18'11"	6.07	19'11"	6.47	21'3"
<b>D</b>	4.48	14'8"	4.78	15'8"	5.16	16'11"
<b>E</b>	5.57	18'3"	5.88	19'3"	6.30	20'8"
<b>F</b>	9.67	31'9"	9.54	31'3"	9.76	32'0"

- 320D ● 320D L — Japan/China/Indonesia/Brazil Sourced
- 320D RR ● 320D LRR ● 321D LCR — Japan Sourced

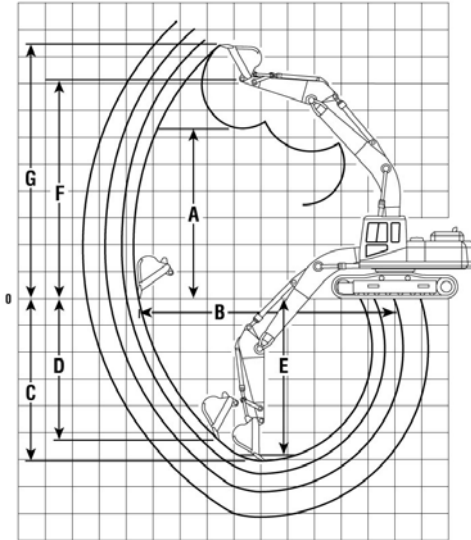

**One-Piece Boom Digging Envelope**

- Standard shoes and undercarriage

**KEY:**

- A** Maximum loading height of bucket with teeth
- B** Maximum reach at ground level
- C** Maximum digging depth
- D** Maximum vertical wall
- E** Maximum depth of cut for 2.44 m (8'0") level bottom (straight clean up)
- F** Maximum bucket hinge pin height
- G** Maximum height, to bucket teeth at highest arc

**Japan/China/Indonesia/Brazil Sourced**

**320D, 320D L  
with Reach Boom**

**320D, 320D L  
with Mass Boom**

Stick	1.9 m		2.5 m		2.9 m		3.9 m		2.4 m	
	m	ft	m	ft	m	ft	m	ft	m	ft
<b>A</b>	5.98	19'7"	6.37	20'11"	6.57	21'7"	7.02	23'0"	5.83	19'2"
<b>B</b>	8.90	29'2"	9.38	30'9"	9.78	32'1"	10.68	35'0"	8.85	29'0"
<b>C</b>	5.71	18'9"	6.22	20'5"	6.64	21'9"	7.58	24'10"	5.78	19'0"
<b>D</b>	4.83	15'10"	5.64	18'6"	6.05	19'10"	6.96	22'10"	5.03	16'6"
<b>E</b>	5.47	17'11"	6.03	19'9"	6.47	21'3"	7.44	24'5"	5.57	18'3"
<b>F</b>	7.45	24'5"	7.87	25'9"	8.06	26'5"	8.41	27'7"	7.43	24'5"
<b>G</b>	8.93	29'4"	9.21	30'3"	9.41	30'10"	9.87	32'5"	8.81	28'11"

**Japan Sourced**

**320D RR, 320D LRR  
with Reach Boom**

**321D LCR  
with Reach Boom**

Stick	2.5 m		2.9 m		3.9 m		2.9 m	
	m	ft	m	ft	m	ft	m	ft
<b>A</b>	6.37	20'11"	6.57	21'7"	6.93	22'9"	7.98	26'2"
<b>B</b>	9.38	30'9"	9.78	32'1"	10.63	34'11"	9.69	31'9"
<b>C</b>	6.22	20'5"	6.64	21'9"	7.58	24'10"	6.62	21'9"
<b>D</b>	5.64	18'6"	6.05	19'10"	6.80	22'4"	5.93	19'5"
<b>E</b>	6.03	19'9"	6.47	21'3"	7.25	23'9"	6.44	21'2"
<b>F</b>	7.87	25'9"	8.06	26'5"	8.41	27'7"	9.49	31'2"
<b>G</b>	9.21	30'3"	9.41	30'10"	9.73	31'11"	10.92	35'10"

# Excavators

## Range Dimensions

- 323D L — Belgium/Brazil/Japan/China Sourced

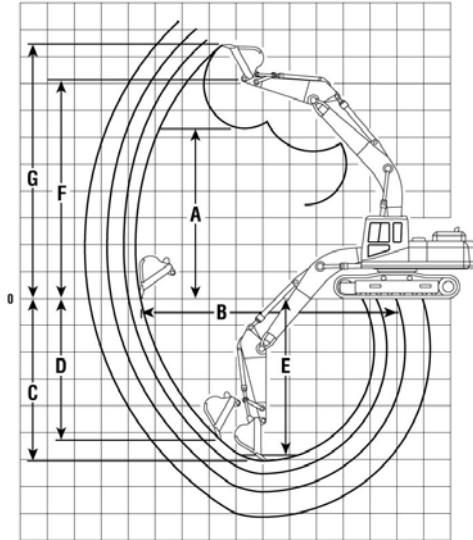

### One-Piece Boom Digging Envelope

- Standard shoes and undercarriage

#### KEY:

- A** Maximum loading height of bucket with teeth
- B** Maximum reach at ground level
- C** Maximum digging depth
- D** Maximum vertical wall
- E** Maximum depth of cut for 2.44 m (8'0") level bottom (straight clean up)
- F** Maximum bucket hinge pin height
- G** Maximum height, to bucket teeth at highest arc

### Belgium/Brazil Sourced

Stick	323D L with Reach Boom				323D L with Mass Boom			
	1.9 m	6'3"	2.5 m	8'2"	2.92 m	9'7"	1.9 m	6'3"
	m	ft	m	ft	m	ft	m	ft
<b>A</b>	5.99	19'8"	6.59	21'7"	6.77	22'2"	5.71	18'9"
<b>B</b>	8.98	29'5"	9.44	31'0"	9.86	32'4"	8.52	27'11"
<b>C</b>	5.78	19'0"	6.20	20'4"	6.65	21'10"	5.33	17'6"
<b>D</b>	3.74	12'3"	5.09	16'8"	5.52	18'1"	3.57	11'9"
<b>E</b>	5.51	18'1"	5.99	19'8"	6.47	21'3"	5.09	16'8"
<b>F</b>	—	—	—	—	—	—	—	—
<b>G</b>	8.94	29'4"	9.38	30'9"	9.58	31'5"	8.71	28'7"

### Japan Sourced

Stick	323D L with Reach Boom		323D L with Mass Boom		323D L with Reach Boom		323D L with Mass Boom					
	2.5 m	8'2"	2.92 m	9'7"	2.4 m	7'10"	2.5 m	8'2"	2.9 m	9'6"	2.4 m	7'10"
	m	ft	m	ft	m	ft	m	ft	m	ft	m	ft
<b>A</b>	6.59	21'7"	6.77	22'2"	5.83	19'1"	6.30	20'8"	6.50	21'4"	5.72	18'10"
<b>B</b>	9.44	31'0"	9.86	32'4"	8.85	29'0"	9.45	31'0"	9.85	32'4"	8.96	29'5"
<b>C</b>	6.20	20'4"	6.65	21'10"	5.78	19'0"	6.29	20'7"	6.71	22'0"	5.89	19'4"
<b>D</b>	5.09	16'8"	5.52	18'1"	5.03	16'6"	5.51	18'1"	5.86	19'2"	4.80	15'8"
<b>E</b>	5.99	19'8"	6.47	21'3"	5.57	18'3"	5.95	19'6"	6.38	20'11"	5.54	18'2"
<b>F</b>	—	—	—	—	—	—	—	—	—	—	—	—
<b>G</b>	9.38	30'9"	9.58	31'5"	8.81	28'11"	9.26	30'5"	9.47	31'1"	8.91	29'2"

### China Sourced

- 323D L   ● 323D LN   ● 323D SA — France Sourced
- 324D   ● 324D L — Japan/U.S. Sourced

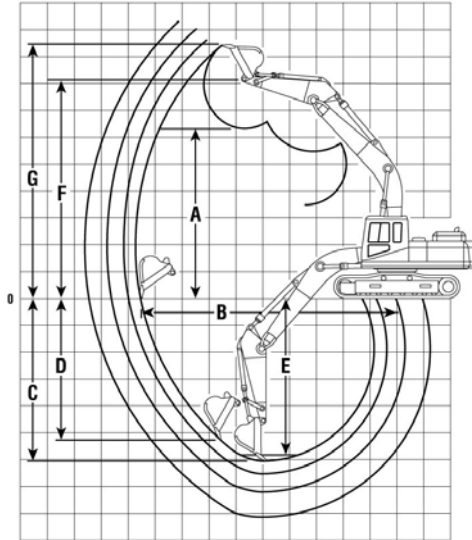

**One-Piece and VA Booms Digging Envelope**

- Standard shoes and undercarriage

**KEY:**

- A** Maximum loading height of bucket with teeth
- B** Maximum reach at ground level
- C** Maximum digging depth
- D** Maximum vertical wall
- E** Maximum depth of cut for 2.44 m (8'0") level bottom (straight clean up)
- F** Maximum bucket hinge pin height
- G** Maximum height, to bucket teeth at highest arc

**France Sourced**

Stick	323D L, 323D LN, 323D SA with VA Boom						323D L, 323D LN, 323D SA with Reach Boom					
	1.9 m	6'3"	2.5 m	8'2"	2.9 m	9'6"	1.9 m	6'3"	2.5 m	8'2"	2.9 m	9'6"
	m	ft	m	ft	m	ft	m	ft	m	ft	m	ft
<b>A</b>	7.51	24'8"	8.09	26'6"	8.43	27'8"	5.97	19'7"	6.57	21'7"	6.74	22'1"
<b>B</b>	9.28	30'5"	9.79	32'1"	10.20	33'5"	8.84	29'0"	9.28	30'5"	9.70	31'10"
<b>C</b>	5.74	18'10"	6.27	20'7"	6.68	21'11"	5.61	18'5"	6.03	19'9"	6.48	21'3"
<b>D</b>	3.46	11'4"	4.10	13'5"	4.52	14'10"	3.60	11'10"	4.94	16'2"	5.38	17'8"
<b>E</b>	5.63	18'6"	6.16	20'2"	6.58	21'7"	5.35	17'7"	5.83	19'2"	6.29	20'8"
<b>F</b>	—	—	—	—	—	—	—	—	—	—	—	—
<b>G</b>	10.74	35'3"	11.17	36'8"	11.51	37'9"	8.88	29'2"	9.31	30'7"	9.51	31'2"

**Japan/U.S. Sourced**

Stick	324D, 324D L with Reach Boom						324D, 324D L with Mass Boom	
	2.5 m	8'2"	2.95 m	9'8"	3.6 m	11'10"	2.5 m	8'2"
	m	ft	m	ft	m	ft	m	ft
<b>A</b>	6.39	21'0"	6.59	21'7"	7.04	23'1"	6.30	20'8"
<b>B</b>	9.40	30'10"	9.83	32'3"	10.55	34'7"	9.45	31'0"
<b>C</b>	6.40	21'0"	6.85	22'6"	7.33	24'1"	6.49	21'3"
<b>D</b>	5.63	18'6"	6.08	19'11"	6.58	21'7"	5.69	18'8"
<b>E</b>	6.20	20'4"	6.67	21'11"	7.17	23'6"	6.30	20'8"
<b>F</b>	—	—	—	—	—	—	—	—
<b>G</b>	9.75	32'0"	9.95	32'8"	9.89	32'5"	9.85	32'4"

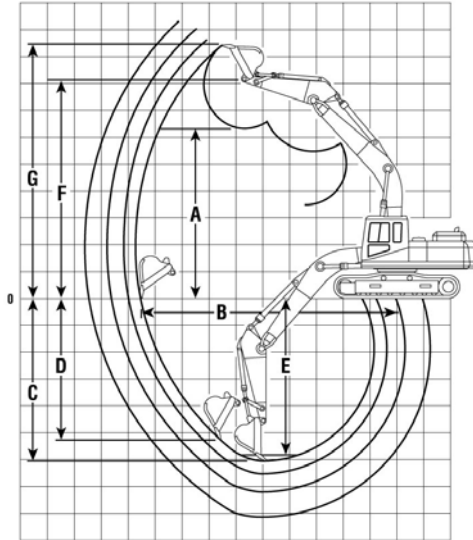

**One-Piece and VA Booms Digging Envelope**

- Standard shoes and undercarriage

**KEY:**

- A** Maximum loading height of bucket with teeth
- B** Maximum reach at ground level
- C** Maximum digging depth
- D** Maximum vertical wall
- E** Maximum depth of cut for 2.44 m (8'0") level bottom (straight clean up)
- F** Maximum bucket hinge pin height
- G** Maximum height, to bucket teeth at highest arc

**Belgium Sourced**

**324D L, 324D LN with 5.9 m (19'4") Reach Boom**

**324D L, 324D LN with 5.3 m (17'5") Mass Boom**

Stick	2.5 m		2.95 m		2 m		2.5 m	
	m	8'2"	m	9'8"	m	6'7"	m	8'2"
<b>A</b>	6.50	21'4"	6.70	22'0"	5.75	18'10"	5.97	19'7"
<b>B</b>	9.62	31'7"	10.05	33'0"	8.65	29'0"	9.11	29'11"
<b>C</b>	6.29	20'8"	6.74	22'1"	5.41	17'9"	5.91	19'5"
<b>D</b>	5.39	17'8"	5.83	19'1"	4.12	13'6"	4.59	15'1"
<b>E</b>	6.08	19'11"	6.56	21'6"	5.19	17'0"	5.72	18'9"
<b>F</b>	8.11	26'7"	8.31	27'3"	7.51	24'8"	7.73	25'4"
<b>G</b>	9.46	31'0"	9.66	31'8"	8.83	29'0"	9.05	29'8"

**Belgium Sourced**

**324D L, 324D LN with 5.6 m (18'4") VA Boom**

Stick	2.5 m		2.9 m	
	m	8'2"	m	9'8"
<b>A</b>	8.007	26'3"	8.346	27'4"
<b>B</b>	9.881	32'5"	10.304	33'10"
<b>C</b>	6.217	20'5"	6.655	21'10"
<b>D</b>	4.066	13'4"	4.498	14'9"
<b>E</b>	6.112	20'1"	6.555	21'6"
<b>F</b>	9.617	31'7"	9.956	32'8"
<b>G</b>	11.237	36'10"	11.575	38'0"

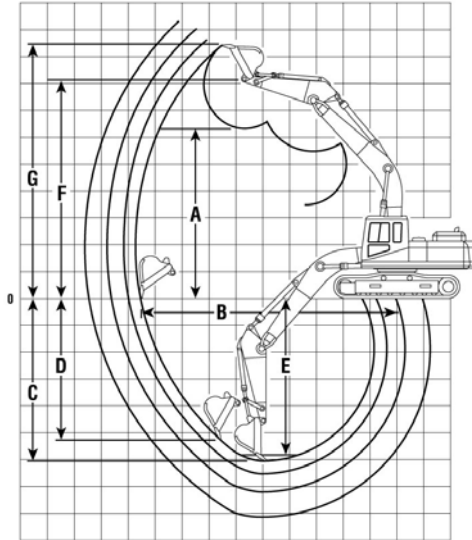

**One-Piece Boom Digging Envelope**

- Standard shoes and undercarriage

**KEY:**

- A** Maximum loading height of bucket with teeth
- B** Maximum reach at ground level
- C** Maximum digging depth
- D** Maximum vertical wall
- E** Maximum depth of cut for 2.44 m (8'0") level bottom (straight clean up)
- F** Maximum bucket hinge pin height
- G** Maximum height, to bucket teeth at highest arc

Japan/U.S. Sourced

**328D LCR  
with Reach Boom**

Stick	2.65 m		8'8"		3.2 m		10'6"	
	m	ft	m	ft	m	ft	m	ft
<b>A</b>	7.82	25'8"	6.91	22'8"				
<b>B</b>	10.08	33'1"	10.66	35'0"				
<b>C</b>	6.37	20'11"	7.28	23'11"				
<b>D</b>	5.73	18'10"	6.14	20'2"				
<b>E</b>	6.19	20'4"	7.13	23'5"				
<b>F</b>	—	—	—	—				
<b>G</b>	10.91	35'10"	10.12	33'2"				

Japan/U.S. Sourced

**329D, 329D L  
with Reach Boom**

**329D, 329D L  
with Mass Boom**

Stick	2 m		2.65 m		3.2 m		3.75 m		2.5 m		3.2 m	
	m	ft	m	ft	m	ft	m	ft	m	ft	m	ft
<b>A</b>	6.31	20'8"	6.76	22'2"	6.91	22'8"	7.10	23'4"	5.97	19'7"	6.43	21'3"
<b>B</b>	9.52	31'3"	10.18	33'5"	10.66	35'0"	11.15	36'7"	9.45	31'0"	10.02	32'11"
<b>C</b>	6.06	19'11"	6.73	22'1"	7.28	23'11"	7.83	25'8"	6.13	20'1"	6.74	22'1"
<b>D</b>	5.26	17'3"	5.81	19'1"	6.14	20'2"	6.59	21'7"	5.05	16'7"	5.61	18'5"
<b>E</b>	5.83	19'2"	6.56	21'6"	7.13	23'5"	7.69	25'3"	5.94	19'6"	6.58	21'7"
<b>F</b>	7.97	26'2"	—	—	—	—	—	—	—	—	—	—
<b>G</b>	9.46	31'0"	10.00	32'10"	10.12	33'2"	10.30	33'9"	9.23	30'3"	9.69	31'9"

# Excavators

## Range Dimensions

● 329D L ● 329D LN — Belgium Sourced

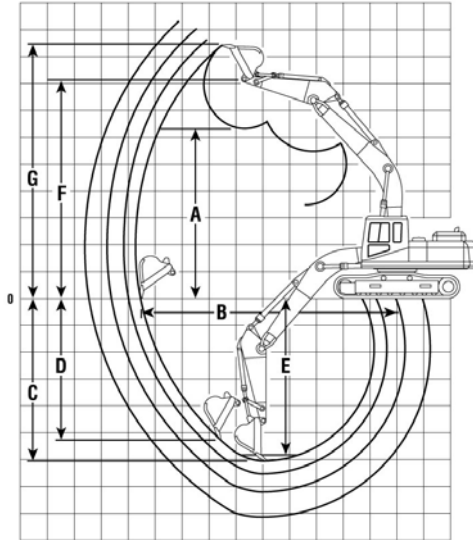

### One-Piece and VA Booms Digging Envelope

- Standard shoes and undercarriage

#### KEY:

- A** Maximum loading height of bucket with teeth
- B** Maximum reach at ground level
- C** Maximum digging depth
- D** Maximum vertical wall
- E** Maximum depth of cut for 2.44 m (8'0") level bottom (straight clean up)
- F** Maximum bucket hinge pin height
- G** Maximum height, to bucket teeth at highest arc

### Belgium Sourced

#### 329D L, 329D LN with 6.15 m (20'2") Reach Boom

#### 329D L, 329D LN with 5.55 m (18'3") Mass Boom

Stick	2 m		2.7 m		3.2 m		2.5 m	
	m	ft	m	ft	m	ft	m	ft
<b>A</b>	6.31	20'8"	6.87	22'6"	7.02	23'0"	6.09	20'0"
<b>B</b>	9.52	31'3"	10.13	33'3"	10.60	34'9"	9.34	30'8"
<b>C</b>	6.06	19'11"	6.62	21'9"	7.17	23'6"	6.01	19'9"
<b>D</b>	4.76	15'7"	6.44	21'1"	6.51	21'4"	4.71	15'5"
<b>E</b>	5.83	19'1"	5.98	19'7"	7.01	23'0"	6.44	21'1"
<b>F</b>	8.07	26'6"	8.48	27'10"	8.63	28'4"	7.85	25'9"
<b>G</b>	9.38	30'9"	9.88	32'5"	9.99	32'9"	10.41	34'2"

### Belgium Sourced

#### 329D L, 329D LN with 5.85 m (19'2") VA Boom

Stick	2 m		2.6 m		3.2 m	
	m	ft	m	ft	m	ft
<b>A</b>	7.680	25'2"	8.444	27'8"	8.778	28'10"
<b>B</b>	9.791	32'1"	10.333	33'11"	10.819	35'6"
<b>C</b>	5.933	19'6"	6.466	21'3"	6.984	22'11"
<b>D</b>	3.719	12'2"	4.358	14'4"	4.887	16'0"
<b>E</b>	5.823	19'1"	6.364	20'10"	6.889	22'7"
<b>F</b>	9.444	21'0"	10.054	33'0"	10.388	34'1"
<b>G</b>	11.168	36'8"	11.679	38'4"	12.006	39'5"

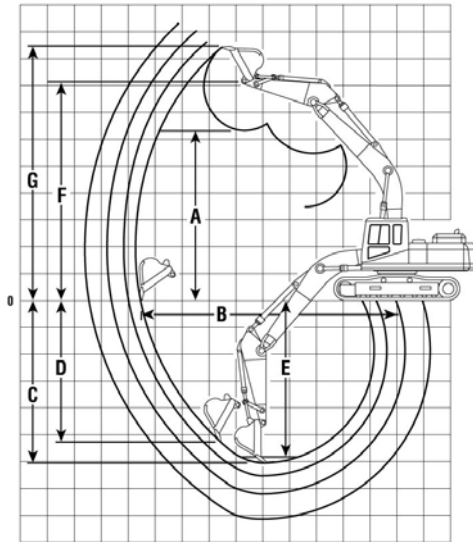

**One-Piece Boom Digging Envelope**

- Standard shoes and undercarriage

**KEY:**

- A** Maximum loading height of bucket with teeth
- B** Maximum reach at ground level
- C** Maximum digging depth
- D** Maximum vertical wall
- E** Maximum depth of cut for 2.44 m (8'0") level bottom (straight clean up)
- F** Maximum bucket hinge pin height
- G** Maximum height, to bucket teeth at highest arc

Japan/U.S./Brazil Sourced

**336D, 336D L  
with Reach Boom**

**336D, 336D L  
with Mass Boom**

Stick	2.15 m * 7'1"		2.8 m * 9'2"		3.2 m 10'6"		3.9 m 12'10"		2.15 m * 7'1"		2.55 m 8'4"	
	m	ft	m	ft	m	ft	m	ft	m	ft	m	ft
<b>A</b>	6.50	21'4"	7.20	23'7"	7.11	23'4"	7.54	24'9"	6.39	27'0"	6.63	21'9"
<b>B</b>	10.09	33'1"	10.62	34'10"	11.00	36'1"	11.71	38'5"	9.79	31'11"	10.24	33'7"
<b>C</b>	6.53	21'5"	6.99	22'11"	7.49	24'7"	8.19	26'10"	6.20	20'4"	6.63	21'9"
<b>D</b>	5.35	17'7"	6.04	19'10"	6.13	20'1"	7.15	23'6"	5.23	17'2"	4.42	14'6"
<b>E</b>	6.31	20'8"	6.82	22'5"	7.33	24'0"	8.05	26'5"	5.99	19'8"	6.46	21'2"
<b>F</b>	8.35	27'5"	8.86	29'1"	—	—	—	—	8.23	27'0"	—	—
<b>G</b>	9.92	32'7"	10.34	33'11"	10.27	33'8"	10.75	35'3"	9.84	32'2"	10.02	32'11"



# Excavators

## Range Dimensions

● 336D L ● 336D LN — Belgium Sourced

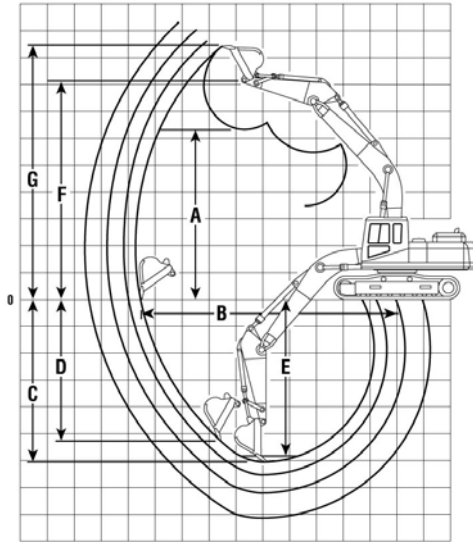

### One-Piece Boom Digging Envelope

- Standard shoes and undercarriage

#### KEY:

- A** Maximum loading height of bucket with teeth
- B** Maximum reach at ground level
- C** Maximum digging depth
- D** Maximum vertical wall
- E** Maximum depth of cut for 2.44 m (8'0") level bottom (straight clean up)
- F** Maximum bucket hinge pin height
- G** Maximum height, to bucket teeth at highest arc

## Belgium Sourced

### 336D L, 336D LN with Reach Boom

### 336D L, 336D LN with Mass Boom

Stick	2.15 m 7'1"		2.8 m 9'2"		3.2 m 10'6"		3.9 m 12'10"		2.15 m 7'1"		2.55 m 8'4"	
	m	ft	m	ft	m	ft	m	ft	m	ft	m	ft
<b>A</b>	6.53	21'1"	7.20	23'7"	7.20	23'7"	7.64	25'1"	6.41	21'0"	6.69	21'11"
<b>B</b>	10.07	33'0"	10.62	34'10"	10.92	35'10"	11.64	38'2"	9.76	32'0"	10.18	33'5"
<b>C</b>	6.50	21'4"	6.99	22'11"	7.39	24'3"	8.09	26'6"	6.17	20'3"	6.57	21'7"
<b>D</b>	4.65	15'3"	4.47	14'8"	4.45	14'7"	6.70	22'0"	4.31	14'2"	4.37	14'4"
<b>E</b>	6.28	20'7"	6.82	22'4"	7.23	23'9"	7.96	26'1"	5.97	19'7"	6.40	21'0"
<b>F</b>	8.43	27'8"	8.96	29'5"	8.96	29'5"	9.40	30'10"	8.31	27'3"	8.59	28'2"
<b>G</b>	9.82	32'3"	10.30	33'9"	10.24	33'7"	10.71	35'2"	9.74	31'11"	10.07	33'0"

\*Not available on U.S. sourced machines.

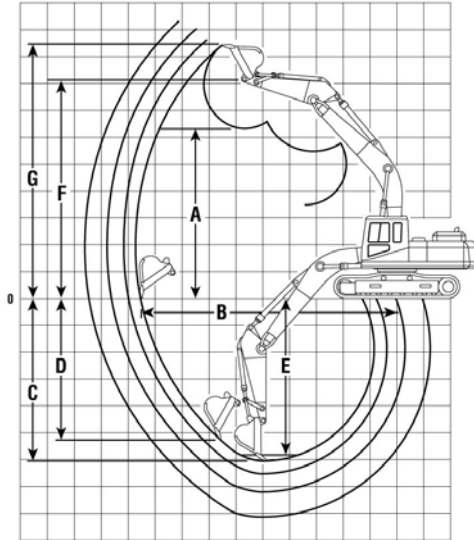

**One-Piece Boom Digging Envelope**

- Standard shoes and undercarriage

**KEY:**

- A** Maximum loading height of bucket with teeth
- B** Maximum reach at ground level
- C** Maximum digging depth
- D** Maximum vertical wall
- E** Maximum depth of cut for 2.44 m (8'0") level bottom (straight clean up)
- F** Maximum bucket hinge pin height
- G** Maximum height, to bucket teeth at highest arc

Japan/U.S. Sourced

Stick	345D L – FIX with Long Reach Boom				345D L – FIX with Reach Boom				345D L – FIX with Mass Boom			
	3.9 m	12'10"	4.3 m	14'1"	3.35 m	11'0"	3.9 m	12'10"	2.5 m	8'2"	3 m	9'10"
	m	ft	m	ft	m	ft	m	ft	m	ft	m	ft
<b>A</b>	7.75	25'5"	7.87	25'10"	7.42	24'4"	7.41	24'4"	6.64	21'9"	6.83	22'5"
<b>B</b>	12.58	41'3"	12.94	42'5"	11.71	38'5"	12.12	29'9"	10.70	35'1"	11.16	36'7"
<b>C</b>	8.52	27'11"	8.92	29'3"	7.65	25'1"	8.20	26'11"	6.70	22'0"	7.20	23'7"
<b>D</b>	5.33	17'6"	5.86	19'3"	5.21	17'1"	5.30	17'4"	4.22	13'10"	4.66	16'3"
<b>E</b>	8.38	27'6"	8.79	28'10"	7.50	24'7"	8.07	26'6"	6.53	21'5"	7.05	23'1"
<b>F</b>	9.61	31'6"	9.74	31'11"	9.29	30'6"	9.28	30'5"	8.64	28'4"	8.83	29'0"
<b>G</b>	10.94	35'11"	11.09	36'5"	10.73	35'2"	10.64	34'11"	10.15	33'4"	10.35	33'11"

# Excavators

## Range Dimensions

- 345D L – VG — U.S. Sourced
- 345D L – VG — Belgium Sourced

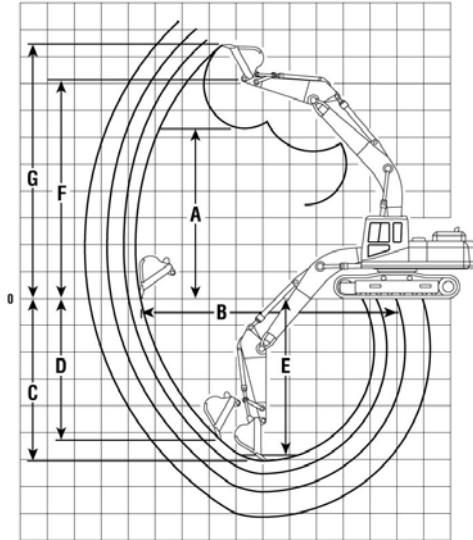

### One-Piece Boom Digging Envelope

- Standard shoes and undercarriage

#### KEY:

- A** Maximum loading height of bucket with teeth
- B** Maximum reach at ground level
- C** Maximum digging depth
- D** Maximum vertical wall
- E** Maximum depth of cut for 2.44 m (8'0") level bottom (straight clean up)
- F** Maximum bucket hinge pin height
- G** Maximum height, to bucket teeth at highest arc

### U.S. Sourced

#### 345D L – VG with Reach Boom

#### 345D L – VG with Mass Boom

Stick	3.35 m		3.9 m		2.5 m		3 m	
	m	ft	m	ft	m	ft	m	ft
<b>A</b>	7.57	24'10"	7.89	25'11"	6.64	21'9"	6.83	22'5"
<b>B</b>	11.68	38'4"	12.55	41'2"	10.70	35'2"	11.16	36'7"
<b>C</b>	7.50	24'7"	8.37	27'6"	6.70	22'0"	7.20	23'8"
<b>D</b>	5.07	16'7"	5.19	17'0"	4.22	13'10"	4.66	15'3"
<b>E</b>	7.36	24'2"	8.23	27'0"	6.53	21'5"	7.05	23'1"
<b>F</b>	9.44	30'11"	9.42	30'11"	8.79	28'10"	8.98	29'5"
<b>G</b>	10.88	35'8"	10.78	35'5"	10.30	33'9"	10.49	34'5"

### Belgium Sourced

#### 345D L – VG with Reach Boom

#### 345D L – VG with Mass Boom

Stick	2.9 m		3.35 m		2.5 m		3 m	
	m	ft	m	ft	m	ft	m	ft
<b>A</b>	7.41	24'4"	7.58	24'10"	6.74	22'0"	6.93	22'8"
<b>B</b>	11.29	37'0"	11.71	38'5"	10.75	35'4"	11.22	36'10"
<b>C</b>	7.04	23'1"	7.42	24'4"	6.61	21'8"	7.11	23'4"
<b>D</b>	4.89	16'0"	5.30	17'4"	3.92	12'10"	4.36	14'4"
<b>E</b>	6.88	22'7"	7.35	24'1"	6.44	21'1"	6.96	22'10"
<b>F</b>	9.11	29'11"	9.29	30'6"	8.64	28'4"	8.83	29'0"
<b>G</b>	10.83	35'6"	11.00	36'1"	10.41	34'2"	10.60	34'9"

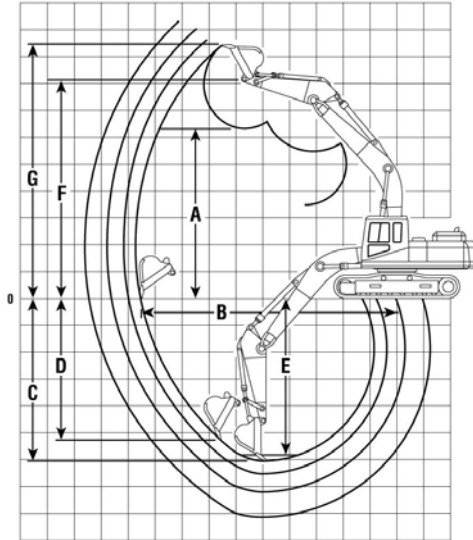

**One-Piece Boom Digging Envelope**

- Standard shoes and undercarriage
- Lug height not included

**KEY:**

- A** Maximum loading height of bucket with teeth
- B** Maximum reach at ground level
- C** Maximum digging depth
- D** Maximum vertical wall
- E** Maximum depth of cut for 2.44 m (8'0") level bottom (straight clean up)
- F** Maximum bucket hinge pin height
- G** Maximum height, to bucket teeth at highest arc

**Belgium Sourced**

**365C L with Reach Boom**

Stick	2.84 m		3.6 m		4.15 m *		4.67 m	
	m	ft	m	ft	m	ft	m	ft
<b>A</b>	8.39	27'6"	8.62	28'3"	8.85	29'0"	9.21	30'3"
<b>B</b>	12.44	40'10"	13.01	42'8"	13.53	44'5"	14.07	46'2"
<b>C</b>	7.68	25'2"	8.38	27'6"	8.93	29'3"	9.45	31'0"
<b>D</b>	6.21	20'4"	6.38	20'11"	6.88	22'7"	7.58	24'10"
<b>E</b>	7.52	24'8"	8.24	27'0"	8.80	28'10"	9.93	32'7"
<b>F</b>	10.50	34'5"	10.66	35'0"	10.96	35'11"	11.25	36'11"
<b>G</b>	12.42	40'9"	12.50	41'0"	12.73	41'9"	13.12	43'0"

\*Not available for all market areas.

**Belgium Sourced**

**365C L with  
6.6 m (21'8") Mass Boom**

**365C L with  
7 m (23'0") Mass Boom**

Stick	2.57 m		3 m		2.57 m		3 m	
	m	ft	m	ft	m	ft	m	ft
<b>A</b>	6.77	22'2"	6.69	21'11"	7.12	23'4"	7.28	23'11"
<b>B</b>	11.04	36'3"	11.44	37'6"	11.46	37'7"	11.86	38'11"
<b>C</b>	6.90	22'8"	7.32	24'0"	7.18	23'7"	7.60	24'11"
<b>D</b>	4.06	13'4"	4.43	14'6"	4.25	13'11"	4.61	15'1"
<b>E</b>	6.74	22'1"	7.17	23'6"	7.02	23'0"	7.46	24'6"
<b>F</b>	9.02	29'7"	9.19	30'2"	9.42	30'11"	9.58	31'5"
<b>G</b>	10.73	35'2"	10.90	35'9"	11.08	36'3"	11.24	36'10"

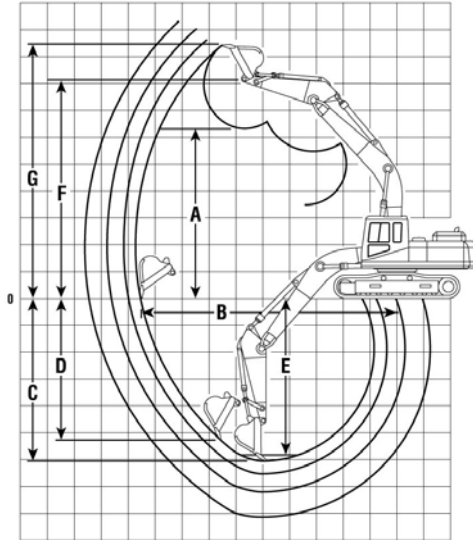

**One-Piece Boom Digging Envelope**

- Standard shoes and undercarriage
- Lug height not included

**KEY:**

- A** Maximum loading height of bucket with teeth
- B** Maximum reach at ground level
- C** Maximum digging depth
- D** Maximum vertical wall
- E** Maximum depth of cut for 2.44 m (8'0") level bottom (straight clean up)
- F** Maximum bucket hinge pin height
- G** Maximum height, to bucket teeth at highest arc

**Belgium Sourced**

**385C L with 10 m (32'10") Reach Boom**

**385C L with 8.4 m (27'7") General Purpose Boom**

Stick	4.4 m		5.5 m		3.4 m		3.7 m	
	m	ft	m	ft	m	ft	m	ft
<b>A</b>	10.78	35'4"	11.20	36'9"	9.23	30'3"	9.25	30'4"
<b>B</b>	16.02	52'7"	17.04	55'11"	13.81	45'4"	13.75	45'1"
<b>C</b>	10.45	34'3"	11.55	37'11"	8.55	28'1"	8.68	28'6"
<b>D</b>	5.37	17'7"	6.30	20'8"	5.87	19'3"	7.11	23'4"
<b>E</b>	10.33	33'11"	11.45	37'7"	8.41	27'7"	8.55	28'1"
<b>F</b>	12.94	42'5"	13.37	43'10"	—	—	11.40	37'5"
<b>G</b>	14.51	47'7"	14.94	49'0"	13.58	44'7"	13.12	43'0"

**Belgium Sourced**

**385C L with 8.4 m (27'7") General Purpose Boom**

**385C L with 7.25 m (23'9") Mass Boom**

Stick	4.4 m		5.5 m		2.92 m		3.4 m	
	m	ft	m	ft	m	ft	m	ft
<b>A</b>	9.52	31'3"	9.98	32'9"	8.06	26'5"	8.23	27'0"
<b>B</b>	14.48	47'6"	15.52	50'11"	12.28	40'3"	12.70	41'8"
<b>C</b>	9.40	30'10"	10.50	34'5"	7.14	23'5"	7.62	25'5"
<b>D</b>	5.07	16'8"	6.00	19'8"	4.65	15'3"	4.92	16'2"
<b>E</b>	9.28	30'5"	10.40	34'1"	7.00	23'0"	7.49	24'7"
<b>F</b>	11.69	38'4"	12.14	39'10"	10.53	34'6"	10.70	35'1"
<b>G</b>	13.30	43'7"	13.76	45'2"	12.54	41'2"	12.68	41'7"

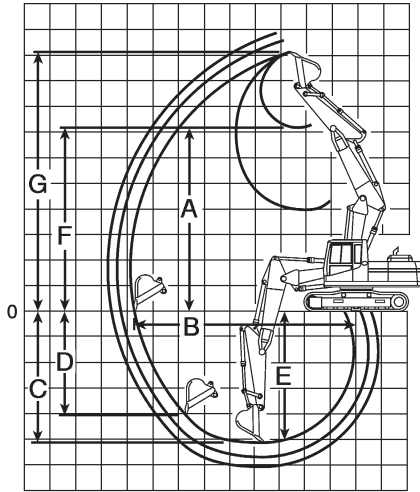

**Variable Adjustable Boom Digging Envelope**

**KEY:**

- A** Maximum loading height of bucket with teeth
- B** Maximum reach at ground level
- C** Maximum digging depth
- D** Maximum vertical wall
- E** Maximum depth of cut for 2.44 m (8'0") level bottom (straight clean up)
- F** Maximum bucket hinge pin height
- G** Maximum height, to bucket teeth at highest arc

**France Sourced**

**312D, 312D L**

Stick	2.1 m		2.5 m		3 m	
	m	ft	m	ft	m	ft
<b>A</b>	6.91	22'8"	7.27	23'10"	7.65	25'1"
<b>B</b>	7.84	25'8"	8.22	27'0"	8.68	28'6"
<b>C</b>	4.73	15'6"	5.13	16'10"	5.61	18'5"
<b>D</b>	2.84	9'4"	3.16	10'5"	3.64	11'11"
<b>E</b>	4.54	14'11"	4.9	16'1"	5.34	17'6"
<b>F</b>	8.03	26'4"	8.36	27'5"	8.77	28'10"
<b>G</b>	9.14	30'0"	9.49	31'1"	9.89	32'5"

**France Sourced**

**315D L**

Stick	1.85 m		2.25 m		2.6 m		3.1 m	
	m	ft	m	ft	m	ft	m	ft
<b>A</b>	6.92	22'8"	7.26	23'10"	7.45	24'5"	7.81	25'7"
<b>B</b>	7.97	26'2"	8.36	27'5"	8.68	28'6"	9.10	29'10"
<b>C</b>	4.65	15'4"	5.06	16'7"	5.40	17'8"	5.85	19'2"
<b>D</b>	3.12	10'2"	3.52	11'7"	3.88	12'8"	4.36	14'4"
<b>E</b>	4.59	15'0"	4.99	16'5"	5.34	17'6"	5.81	19'1"
<b>F</b>	8.21	26'11"	8.54	28'0"	8.77	28'10"	9.10	29'11"
<b>G</b>	9.49	31'1"	9.82	32'2"	10.09	33'1"	10.40	34'1"

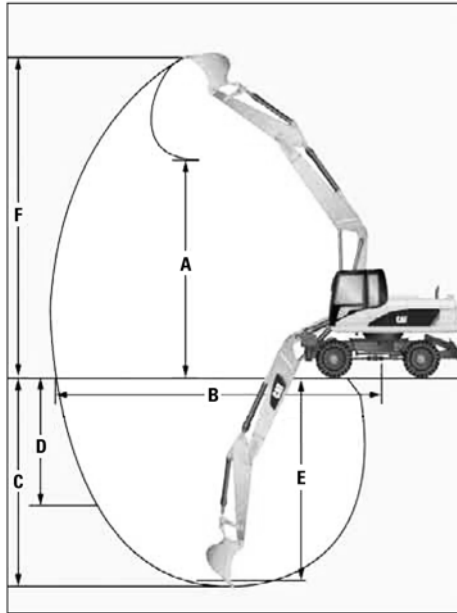

**Hydraulic Adjustable Boom Digging Envelope**

- Standard 10 × 20 tires and undercarriage
- General purpose bucket

**KEY:**

- A** Maximum loading height of bucket with teeth
- B** Maximum reach at ground level
- C** Maximum digging depth
- D** Maximum vertical wall
- E** Maximum depth of cut for 2.5 m (8'2") level bottom
- F** Maximum height, to bucket teeth at highest arc

**M313D**

Stick	2 m	6'7"	2.3 m	7'7"	2.6 m	8'6"
Bucket	0.64 m <sup>3</sup>	0.84 yd <sup>3</sup>	0.64 m <sup>3</sup>	0.84 yd <sup>3</sup>	0.56 m <sup>3</sup>	0.73 yd <sup>3</sup>
	m	ft	m	ft	m	ft
<b>A</b>	6.90	22'8"	7.06	23'2"	7.29	23'11"
<b>B</b>	8.49	27'10"	8.74	28'8"	9.03	29'7"
<b>C</b>	5.16	16'11"	5.45	17'11"	5.75	18'10"
<b>D</b>	3.50	11'6"	3.60	11'10"	3.89	12'9"
<b>E</b>	4.92	16'2"	5.23	17'2"	5.55	18'2"
<b>F</b>	9.67	31'9"	9.82	32'3"	10.06	33'0"

**M315D**

Stick	2.1 m	6'11"	2.4 m	7'10"	2.6 m	8'6"
Bucket	0.815 m <sup>3</sup>	1.07 yd <sup>3</sup>	0.7 m <sup>3</sup>	0.92 yd <sup>3</sup>	0.7 m <sup>3</sup>	0.92 yd <sup>3</sup>
	m	ft	m	ft	m	ft
<b>A</b>	6.95	22'10"	7.14	23'5"	7.30	23'11"
<b>B</b>	8.91	29'3"	9.19	30'2"	9.38	30'9"
<b>C</b>	5.59	18'4"	5.89	19'4"	6.09	20'0"
<b>D</b>	3.72	12'2"	3.92	12'10"	4.09	13'5"
<b>E</b>	5.37	17'7"	5.69	18'8"	5.90	19'4"
<b>F</b>	10.04	32'11"	10.23	33'7"	10.38	34'1"

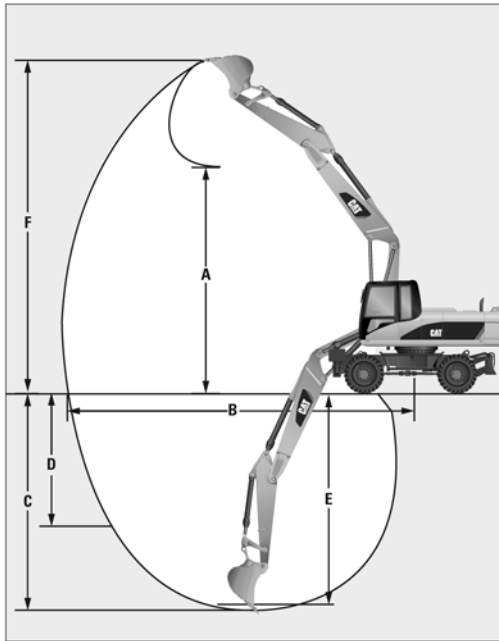

**Hydraulic Adjustable Boom Digging Envelope**

- Standard 10 × 20 tires and undercarriage
- General purpose bucket

**KEY:**

- A** Maximum loading height of bucket with teeth
- B** Maximum reach at ground level
- C** Maximum digging depth
- D** Maximum vertical wall
- E** Maximum depth of cut for 2.5 m (8'2") level bottom
- F** Maximum height, to bucket teeth at highest arc

**M316D**

**M318D**

Stick	2.1 m	6'11"	2.4 m	7'10"	2.6 m	8'6"	2.2 m	7'3"	2.5 m	8'2"	2.8 m	9'2"
Bucket	0.815 m <sup>3</sup>	1.07 yd <sup>3</sup>	0.815 m <sup>3</sup>	1.07 yd <sup>3</sup>	0.7 m <sup>3</sup>	0.92 yd <sup>3</sup>	0.91 m <sup>3</sup>	1.19 yd <sup>3</sup>	0.91 m <sup>3</sup>	1.19 yd <sup>3</sup>	0.7 m <sup>3</sup>	0.92 yd <sup>3</sup>
	m	ft	m	ft	m	ft	m	ft	m	ft	m	ft
<b>A</b>	6.97	22'10"	7.16	23'6"	7.32	24'0"	6.70	22'0"	6.97	22'10"	7.19	23'7"
<b>B</b>	8.91	29'3"	9.19	30'2"	9.38	30'9"	8.97	29'5"	9.30	30'6"	9.59	31'5"
<b>C</b>	5.57	18'3"	5.87	19'3"	6.07	19'11"	5.75	18'10"	6.06	19'11"	6.36	20'10"
<b>D</b>	3.70	12'2"	3.90	12'10"	4.07	13'4"	3.22	10'7"	3.68	12'1"	3.96	13'0"
<b>E</b>	5.35	17'7"	5.67	18'7"	5.88	19'3"	5.54	18'2"	5.87	19'3"	6.18	20'3"
<b>F</b>	10.06	33'0"	10.25	33'7"	10.40	34'1"	9.71	31'10"	10.00	32'10"	10.21	33'6"

**M322D**

Stick	2.2 m	7'3"	2.5 m	8'2"	2.9 m	9'6"
Bucket	1.04 m <sup>3</sup>	1.36 yd <sup>3</sup>	0.805 m <sup>3</sup>	1.05 yd <sup>3</sup>	0.805 m <sup>3</sup>	1.05 yd <sup>3</sup>
	m	ft	m	ft	m	ft
<b>A</b>	6.93	22'9"	7.17	23'6"	7.50	24'7"
<b>B</b>	9.59	31'5"	9.83	32'3"	10.23	33'7"
<b>C</b>	5.99	19'8"	6.28	20'7"	6.68	21'11"
<b>D</b>	4.42	14'6"	4.45	14'7"	4.83	15'10"
<b>E</b>	5.78	19'0"	6.09	20'0"	6.51	21'4"
<b>F</b>	10.56	34'8"	10.62	34'10"	10.93	35'10"



## EXCAVATOR LIFTING CAPACITY

On many sewer jobs an excavator must lift and swing heavy pipe and manboxes in and out of the trench, place manholes and unload material from trucks. In some situations the excavator's lift requirements may be so critical that they determine the size excavator selected.

An excavator's lift capacity depends on its weight, center of gravity, the lift point position (see sketches) and its hydraulic capability. An excavator's lifting capability for any given lift position is limited by its tipping stability or hydraulic capacity.

Changes in boom, stick and bucket position affect attachment geometry and can drastically change a machine's hydraulic lifting capacity. Caterpillar defines excavator lifting capabilities using the following SAE guidelines.

**Tipping Conditions** — An excavator is considered to be at the tipping point when the weight in the bucket acting at the center of gravity causes the rear rollers to lift clear of the track rails. Suspended loads are considered to be hung from the back of the excavator's bucket or bucket linkage by a sling or chain. Weights of attachments, slings or auxiliary lifting devices are considered part of the suspended load.

Thus, the tipping load is defined as the load producing a tipping condition at a specified radius. The load radius shall be measured as the horizontal distance from the axis of upper structure rotation (before loading) to the center of vertical load line with load applied (dimension A, below). The rating height is based on the vertical distance of the bucket lift point to the ground (dimension B).

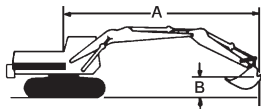

- A. Radius from swing centerline
- B. Bucket lift point height

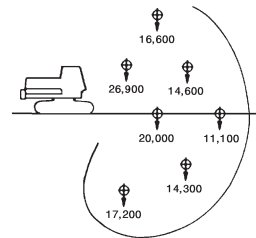

**HYPOTHETICAL MACHINE**

**Rated Hoist Load** — The rated load is established using the vertical distance of the lifting point to the ground and the radius of load. Ratings for the ability of a specific machine attachment to lift a load slung from the designated bucket are defined as follows:

- a. The rated load will not exceed 75% of the tipping load.
- b. The rated load will not exceed 87% of the excavator's hydraulic capacity. This means the machine should be able to lift 115% of the rated load.
- c. The rated load will not exceed the machine's structural capability.

This drawing shows how an excavator's lifting capacity can vary with load position:

**HYPOTHETICAL MACHINE**

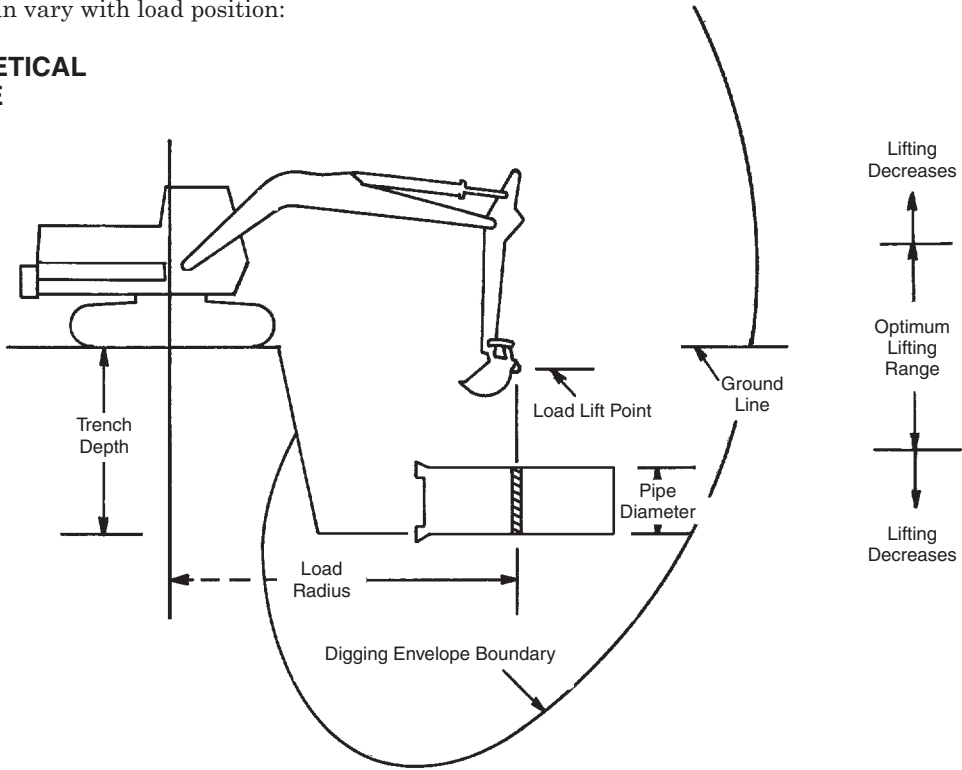

**Tips for Lifting Above Ground:**

Get the load as close to the excavator as possible.  
Use a cable short enough and position the excavator so as to put the load lift point in the “optimum lifting range” (see sketch).

*Problem:* Long reach cable — Can't lift.

*Solution:* Shorten reach and cable — Can lift.

**Tips for Lifting Below Grade:**

Use a cable for sufficient length to position the load lift point in the “optimum lifting range”.

*Problem:* Short cable, deep trench — Can't lift.

*Solution:* Lengthen cable to locate bucket hinge pin in optimum lifting area — Can lift.

**GROUND LEVEL LIFTING CAPACITIES**

The lifting capacities that are shown on the following pages are with the lifting point at ground level. These capacities are rated according to SAE Std. No. J1097.

(For lifting capacities at other heights or with other tools, refer to current Specification Sheets.)

# Excavators

## Lifting Capacity At Ground Level

● 301.6C ● 301.8C ● 302.5C ● 303C CR

### 301.6C ● Rubber Track ● Canopy ● Blade Raised

Stick	Bucket	kg	1 m 3'3"		1.5 m 5'0"		2 m 6'7"		2.5 m 8'2"		3 m 9'10"		At Max. Reach	
			Front	Side	Front	Side	Front	Side	Front	Side	Front	Side	Front	Side
1090 mm	400 mm	kg	350	350	690	440	490	300	350	220	270	170	210	130
3'6"	16"	lb	770	770	1520	970	1080	660	770	480	590	370	460	280

### 301.6C ● Rubber Track ● Canopy ● Blade Lowered

Stick	Bucket	kg	1 m 3'3"		1.5 m 5'0"		2 m 6'7"		2.5 m 8'2"		3 m 9'10"		At Max. Reach	
			Front	Side	Front	Side	Front	Side	Front	Side	Front	Side	Front	Side
1090 mm	400 mm	kg	350	350	690	510	670	340	470	250	370	190	280	150
3'6"	16"	lb	770	770	1520	1120	1470	750	1030	550	810	410	610	330

### 301.8C ● Rubber Track ● Canopy ● Blade Lowered

Stick	Bucket	kg	1 m 3'3"		1.5 m 5'0"		2 m 6'7"		2.5 m 8'2"		3 m 9'10"		At Max. Reach	
			Front	Side	Front	Side	Front	Side	Front	Side	Front	Side	Front	Side
890 mm	400 mm	kg	—	—	680	680	680	530	490	380	380	300	300	250
2'11"	16"	lb	—	—	1490	1490	1490	1160	1080	830	830	660	660	550
1090 mm	400 mm	kg	350	350	690	690	670	530	470	380	370	290	280	220
3'6"	16"	lb	770	770	1520	1520	1470	1160	1030	830	810	630	610	480

### 301.8C ● Rubber Track ● Canopy ● Blade Raised

Stick	Bucket	kg	1 m 3'3"		1.5 m 5'0"		2 m 6'7"		2.5 m 8'2"		3 m 9'10"		At Max. Reach	
			Front	Side	Front	Side	Front	Side	Front	Side	Front	Side	Front	Side
890 mm	400 mm	kg	—	—	680	680	480	480	350	350	270	270	220	220
2'11"	16"	lb	—	—	1490	1490	1050	1050	770	770	590	590	480	480
1090 mm	400 mm	kg	350	350	690	690	470	480	340	350	270	270	200	200
3'6"	16"	lb	770	770	1520	1520	1030	1050	750	770	590	590	480	480

### 302.5C ● Rubber Track ● Canopy ● Blade Raised

Stick	Bucket	kg	1.5 m 5'0"		2 m 6'7"		2.5 m 8'2"		3 m 9'10"		3.5 m 11'6"		4 m 13'1"		At Max. Reach	
			Front	Side	Front	Side	Front	Side	Front	Side	Front	Side	Front	Side	Front	Side
1100 mm	400 mm	kg	740*	740*	1020	750	710	540	540	420	430	340	—	—	360	280
3'6"	16"	lb	1630*	1630*	2240	1650	1560	1190	1190	920	940	740	—	—	600	310
1400 mm	400 mm	kg	770	770	1010	750	710	540	540	410	430	330	350	270	320	250
4'6"	16"	lb	1690	1690	2220	1650	1560	1190	1190	900	940	720	770	590	700	550

### 302.5C ● Rubber Track ● Canopy ● Blade Lowered

Stick	Bucket	kg	1.5 m 5'0"		2 m 6'7"		2.5 m 8'2"		3 m 9'10"		3.5 m 11'6"		4 m 13'1"		At Max. Reach	
			Front	Side	Front	Side	Front	Side	Front	Side	Front	Side	Front	Side	Front	Side
1100 mm	400 mm	kg	740*	740*	1470	830	1150	600	890	460	710	370	—	—	600	310
3'6"	16"	lb	1630*	1630*	3240	1830	2535	1323	1962	1014	1565	816	—	—	1323	683
1400 mm	400 mm	kg	770	770	1530	830	1140	590	870	460	700	360	590	300	540	270
4'6"	16"	lb	1690	1690	3370	1830	2510	1300	1910	1010	1540	790	1300	660	1190	590

### 303C CR ● Blade Raised

Stick	kg	2 m 6'7"		2.5 m 8'2"		3 m 9'10"		3.5 m 11'6"		4 m 13'1"		4.5 m 15'0"		At Max. Reach		
		Front	Side	Front	Side	Front	Side	Front	Side	Front	Side	Front	Side	Front	Side	
1260 mm	kg	1050	750	750	550	550	450	450	350	300	300	250	300	250	300	250
4'2"	lb	2315	1653	1654	1213	1213	992	772	772	661	661	551	661	551	661	551
1560 mm	kg	1000	750	700	550	550	400	400	350	250	300	200	300	200	250	200
5'1"	lb	2205	1653	1543	1213	1213	882	882	772	551	661	441	661	441	551	441

\*Load limited by hydraulic capacity rather than tipping.

**303C CR ● Blade Lowered**

Stick		2 m 6'7"		2.5 m 8'2"		3 m 9'10"		3.5 m 11'6"		4 m 13'1"		4.5 m 15'0"		At Max. Reach	
		Front	Side	Front	Side	Front	Side	Front	Side	Front	Side	Front	Side	Front	Side
1260 mm 4'2"	kg lb	1250*	750	1700*	550	1250*	450	1000*	350	850*	300	700*	250	650*	250
		2756*	1653	3748*	1213	2756*	992	2205*	772	1874*	661	1543*	551	1433*	551
1560 mm 5'1"	kg lb	1350*	750	1650*	550	1200*	400	950*	350	800*	250	700*	200	600*	200
		2976*	1653	3638*	1213	2646*	882	2094*	772	1764*	551	1543*	441	1323*	441

**303.5C CR ● Blade Raised**

Stick		2 m 6'7"		2.5 m 8'2"		3 m 9'10"		3.5 m 11'6"		4 m 13'1"		4.5 m 15'0"		At Max. Reach	
		Front	Side	Front	Side	Front	Side	Front	Side	Front	Side	Front	Side	Front	Side
1315 mm 4'4"	kg lb	—	—	1028	886	760	662	596	522	484	425	—	—	380	334
		—	—	2203	1902	1633	1424	1282	1124	1041	915	—	—	838	737
1615 mm 5'9"	kg lb	—	—	1008	866	748	650	586	512	474	415	—	—	339	296
		—	—	2162	1862	1607	1398	1260	1101	1019	892	—	—	747	653

**303.5C CR ● Blade Lowered**

Stick		2 m 6'7"		2.5 m 8'2"		3 m 9'10"		3.5 m 11'6"		4 m 13'1"		4.5 m 15'0"		At Max. Reach	
		Front	Side	Front	Side	Front	Side	Front	Side	Front	Side	Front	Side	Front	Side
1315 mm 4'4"	kg lb	—	—	2150*	970	1634*	721	1281*	567	1050*	462	—	—	825*	389
		—	—	4632*	2081	3514*	1550	2758*	1219	2258*	994	—	—	1823*	859
1615 mm 5'9"	kg lb	—	—	2175*	950	1597*	710	1246*	559	1026*	454	—	—	759*	325
		—	—	4668*	2040	3429*	1528	2682*	1203	2212*	976	—	—	1673*	717

**304C CR ● Reach Boom ● Blade Raised**

Stick		1.5 m 5'0"		2 m 6'7"		2.5 m 8'2"		3 m 9'10"		3.5 m 11'6"		4 m 13'1"	
		Front	Side	Front	Side	Front	Side	Front	Side	Front	Side	Front	Side
1350 mm 4'5"	kg lb	—	—	1450*	1450	1250	1000	950	750	750	600	600	500
		—	—	3350*	3100*	2700	2150	2000	1600	1600	1300	1300	1050
1750 mm 5'9"	kg lb	900*	900*	1400*	1400	1250	950	900	750	700	600	600	450
		2050*	2050*	3200*	3000	2650	2050	1950	1550	1550	1250	1250	1000

Stick		4.5 m 15'0"		5 m 16'5"		At Max. Reach	
		Front	Side	Front	Side	Front	Side
1350 mm 4'5"	kg lb	500	400	—	—	400	350
		1100	900	—	—	850	700
1750 mm 5'9"	kg lb	500	400	400	350	350	250
		1000	800	850	700	700	550

**304C CR ● Reach Boom ● Blade Lowered**

Stick		1.5 m 5'0"		2 m 6'7"		2.5 m 8'2"		3 m 9'10"		3.5 m 11'6"		4 m 13'1"	
		Front	Side	Front	Side	Front	Side	Front	Side	Front	Side	Front	Side
1350 mm 4'5"	kg lb	—	—	1450*	1450*	2150*	1150	2350*	850	2000*	700	1650*	550
		—	—	3350*	3350*	4700*	2500	5200*	1850	4250*	1500	3550*	1200
1750 mm 5'9"	kg lb	900*	900*	1400*	1400*	2000*	1150	2250*	850	1900*	650	1500*	550
		2050*	2050*	3200*	3200*	4450*	2400	5000*	1800	4000*	1450	3350*	1150

Stick		4.5 m 15'0"		5 m 16'5"		At Max. Reach	
		Front	Side	Front	Side	Front	Side
1350 mm 4'5"	kg lb	1400*	500	—	—	900*	400
		3000*	1000	—	—	1900*	800
1750 mm 5'9"	kg lb	1350*	450	1200*	400	750*	300
		2900*	950	2550*	800	1550*	650

\*Load limited by hydraulic capacity rather than tipping.

# Excavators

## Lifting Capacity At Ground Level

● 305C CR ● 305.5 ● 307C ● 307D

### 305C CR ● Blade Raised

Stick	1.5 m 5'0"		2 m 6'7"		2.5 m 8'2"		3 m 9'10"		3.5 m 11'6"		4 m 13'1"		4.5 m 15'0"		At Max. Reach	
	Front	Side	Front	Side	Front	Side	Front	Side	Front	Side	Front	Side	Front	Side	Front	Side
1430 mm 4'8"	kg —	—	1800* 3968*	1800* 3968*	1550 3417	1300 2866	1150 2535	1000 2205	900 1984	800 1764	750 1653	650 1433	650 1433	550 1213	550 1213	450 992
1830 mm 6'0"	kg 1250*	1250* 2756*	1800* 3968*	1800* 3968*	1550 3417	1300 2866	1150 2535	1000 2205	900 1984	800 1764	750 1653	650 1433	650 1433	550 1213	500 1102	400 882

### 305C CR ● Blade Lowered

Stick	1.5 m 5'0"		2 m 6'7"		2.5 m 8'2"		3 m 9'10"		3.5 m 11'6"		4 m 13'1"		4.5 m 15'0"		At Max. Reach	
	Front	Side	Front	Side	Front	Side	Front	Side	Front	Side	Front	Side	Front	Side	Front	Side
1430 mm 4'8"	kg —	—	1800* 3968*	1800* 3968*	2500* 5512*	1300 2866	2550* 5622*	1000 2205	2100* 4630*	800 1764	1750* 3858*	650 1433	1500* 3307*	550 1213	1300* 2866*	450 992
1830 mm 6'0"	kg 1250*	1250* 2756*	1800* 3968*	1800* 3968*	2450* 5401*	1300 2866	2550* 5622*	1000 2205	2050* 4519*	800 1764	1700* 3748*	650 1433	1450* 3197*	550 1213	1150* 2535*	400 882

### 305.5\*\* ● 400 mm (16") Track Shoes ● Blade Lowered ● 700 mm (28") Bucket

Stick			2 m 6'7"		3 m 9'10"		4 m 13'1"		At Max. Reach	
	Front	Side	Front	Side	Front	Side	Front	Side	Front	Side
1665 mm 5'6"	kg —	—	1400* 3086	1400* 3086	2600* 5732	1600 3527	1750* 3858	1050 2315	1000* 2205	650 1433

### 307C\*\*\* ● Reach Boom

Stick	Bucket	3 m 9'10"		4.5 m 15'0"		6 m 20'0"		At Max. Reach	
		Front	Side	Front	Side	Front	Side	Front	Side
1665 mm 5'6"	750 mm 2'6"	kg 2550 5450	2050 4350	1350 2900	2200 2350	—	—	700* 1500*	700* 1500*
2210 mm 7'3"	600 mm 2'0"	kg 2550 5450	2050 4350	1350 2900	1100 2350	—	—	750* 1650*	650 1350

### 307D ● 450 mm (18") Track Shoes ● Blade Lowered ● 600 mm (24") Bucket

Stick			2 m 6'7"		3 m 9'10"		4 m 13'1"		At Max. Reach	
	Front	Side	Front	Side	Front	Side	Front	Side	Front	Side
1665 mm 5'6"	kg 2600* 5732*	2600* 5732*	3800* 8378*	2600 5732	2800* 6173*	1650 3638	800* 1764*	800* 1764*		
2210 mm 7'3"	kg —	—	3650* 8047*	2550 5622	2700* 5952*	1650 3638	850* 1874*	800 1764		

### 307D ● 600 mm (24") Track Shoes ● Blade Lowered ● 600 mm (24") Bucket

Stick			2 m 6'7"		3 m 9'10"		4 m 13'1"		At Max. Reach	
	Front	Side	Front	Side	Front	Side	Front	Side	Front	Side
1665 mm 5'6"	kg 2600* 5732*	2600* 5732*	3800* 8378*	2700 5952	2800* 6173*	1750 3858	800* 1764*	800* 1764*		
2210 mm 7'3"	kg —	—	3650* 8047*	2700 5952	2700* 5952*	1750 3858	850* 1874*	850* 1874*		

\*Load limited by hydraulic capacity rather than tipping.

\*\*China and Korea only.

\*\*\*China only.

**308D CR ● 450 mm (18") Track Shoes ● Blade Lowered ● 600 mm (24") Bucket**

Stick			2 m 6'7"		3 m 9'10"		4 m 13'1"		At Max. Reach	
			Front	Side	Front	Side	Front	Side	Front	Side
1665 mm 5'6"	kg lb	—	—	3700* 8157*	2850 6283	2700* 5952*	1850 4079	1050* 2315*	1050* 2315*	
2210 mm 7'3"	kg lb	—	—	3650* 8047*	2850 6283	2650* 5842*	1800 3968	1100* 2425*	900 1984	

**308D CR ● 600 mm (24") Track Shoes ● Blade Lowered ● 600 mm (24") Bucket**

Stick			2 m 6'7"		3 m 9'10"		4 m 13'1"		At Max. Reach	
			Front	Side	Front	Side	Front	Side	Front	Side
1665 mm 5'6"	kg lb	—	—	3700* 8157*	3050 6724	2700* 5952*	1950 4299	1050* 2315*	1050* 2315*	
2210 mm 7'3"	kg lb	—	—	3650* 8047*	3050 6724	2650* 5842*	1950 4299	1100* 2425*	950 2094	

**308D CR SB ● 450 mm (18") Track Shoes ● Blade Lowered ● 600 mm (24") Bucket**

Stick			2 m 6'7"		3 m 9'10"		4 m 13'1"		At Max. Reach	
			Front	Side	Front	Side	Front	Side	Front	Side
1665 mm 5'6"	kg lb	—	—	3350* 7385*	2450 5401	3700* 8157*	1600 3527	1500* 3307*	800 1764	
2210 mm 7'3"	kg lb	—	—	3200* 7055*	2450 5401	3450* 7606*	1550 3417	1400* 3086*	650 1433	

**308D CR SB ● 600 mm (24") Track Shoes ● Blade Lowered ● 600 mm (24") Bucket**

Stick			2 m 6'7"		3 m 9'10"		4 m 13'1"		At Max. Reach	
			Front	Side	Front	Side	Front	Side	Front	Side
1665 mm 5'6"	kg lb	—	—	3350* 7385*	2700 5952	3700* 8157*	1700 3748	1500* 3307*	850 1874	
2210 mm 7'3"	kg lb	—	—	3200* 7055*	2650 5842	3450* 7606*	1700 3748	1400* 3086*	700 1543	

**311D LRR ● Reach Boom**

Stick			3 m 9'10"		4.5 m 15'0"		6 m 20'0"		7.5 m 25'0"		At Max. Reach	
			Front	Side	Front	Side	Front	Side	Front	Side	Front	Side
2600 mm 8'6"	760 mm 2'6"	kg lb	7200* 15,500*	4850 10,400	3900 8400	2600 5550	2500 5300	1650 3500	—	—	1050* 2300*	1050* 2300*
2800 mm 9'2"	760 mm 2'6"	kg lb	7050* 15,150*	4850 10,450	3900 8400	2600 5550	2450 5300	1650 3500	—	—	1000* 2150*	1000* 2150*

**312C ● Reach Boom**

Stick			3 m 9'10"		4.5 m 15'0"		6 m 20'0"		7.5 m 25'0"		At Max. Reach	
			Front	Side	Front	Side	Front	Side	Front	Side	Front	Side
2100 mm 6'11"	914 mm 3'0"	kg lb	6200* 14,400*	5050 10,850	4100 8800	2750 5900	2600 5600	1800 3800	—	—	1850* 4000*	1300 2850
2500 mm 8'2"	914 mm 3'0"	kg lb	6750* 15,650*	5200 11,100	4150 8900	2800 6000	2650 5650	1800 3850	—	—	1500* 3300*	1200 2600
3000 mm 9'10"	914 mm 3'0"	kg lb	7800* 17,800	5200 11,150	4150 9800	2800 6000	2650 5600	1800 3800	1800 4000	1200 2650	1400* 3050*	1050 2300

\*Load limited by hydraulic capacity rather than tipping.

**France Sourced**

**312D ● 600 mm (24") Track Shoes ● Quick Coupler CW20 ● One-Piece Boom**

Stick		3 m 9'10"		4.5 m 15'0"		6 m 20'0"		7.5 m 25'0"		At Max. Reach	
		Front	Side	Front	Side	Front	Side	Front	Side	Front	Side
2100 mm 6'11"	kg lb	5600* 12,348	5600* 12,348	4520 9967	3090 6813	2940 6483	2050 4520	—	—	2450 5402	1710 3771
2500 mm 8'2"	kg lb	5940* 13,098	5720 12,613	4570 10,077	3140 6924	2960 6527	2070 4564	—	—	2130* 4697	1580 3484
3000 mm 9'10"	kg lb	6650* 14,729	5740 12,657	4570 10,077	3130 6902	2940 6483	2050 4520	2090 4608	1450 3197	1890* 4167	1410 3109

**312D ● 600 mm (24") Track Shoes ● Quick Coupler CW20 ● VA Boom**

Stick		1.5 m 5'0"		3 m 9'10"		4.5 m 15'0"		6 m 20'0"		7.5 m 25'0"		At Max. Reach	
		Front	Side	Front	Side	Front	Side	Front	Side	Front	Side	Front	Side
2100 mm 6'11"	kg lb	5520* 12,172	5520* 12,172	8500* 18,743	6120 13,495	4780 10,540	3310 7299	2970 6549	2060 4542	—	—	2020* 4454	1580 3484
2500 mm 8'2"	kg lb	5420* 11,951	5420* 11,951	8480* 18,698	6280 13,847	4860 10,716	3380 7453	3020 6659	2120 4675	—	—	1800* 3969	1480 3263
3000 mm 9'10"	kg lb	5980* 13,186	5980* 13,186	8380* 18,478	6430 14,178	4850 10,694	3420 7541	3060 6747	2170 4785	2070 4564	1420 3131	1500* 3308	1320 2911

**312D L ● Reach Boom**

Stick	Bucket		3 m 9'10"		4.5 m 15'0"		6 m 20'0"		7.5 m 25'0"		At Max. Reach	
			Front	Side	Front	Side	Front	Side	Front	Side	Front	Side
2800 mm 9'2"	914 mm 3'0"	kg lb	7750* 18,000*	5950 12,750	5100 10,950	3200 6900	3200 6900	2100 4450	—	—	1550* 3350*	1300 2850
3000 mm 9'10"	914 mm 3'0"	kg lb	8200* 18,550*	5650 12,100	5100 10,950	3050 6500	3200 6900	1950 4150	2300 4750*	1400 2900	1400* 3100*	1150 2500

**France Sourced**

**312D L ● 600 mm (24") Track Shoes ● Quick Coupler CW20 ● One-Piece Boom**

Stick		3 m 9'10"		4.5 m 15'0"		6 m 20'0"		7.5 m 25'0"		At Max. Reach	
		Front	Side	Front	Side	Front	Side	Front	Side	Front	Side
2100 mm 6'11"	kg lb	—	—	5400 11,907	3300 7277	3540 7806	2250 4961	—	—	2850 6284	1830 4035
2500 mm 8'2"	kg lb	4770* 10,518	4770* 10,518	5460 12,039	3350 7387	3560 7850	2270 5005	—	—	2370* 5226	1710 3771
3000 mm 9'10"	kg lb	5540* 12,216	5540* 12,216	5460 12,039	3340 7365	3550 7828	2250 4961	2570 5667	1640 3616	2120* 4675	1540 3396

**312D L ● 600 mm (24") Track Shoes ● Quick Coupler CW20 ● VA Boom**

Stick		1.5 m 5'0"		3 m 9'10"		4.5 m 15'0"		6 m 20'0"		7.5 m 25'0"		At Max. Reach	
		Front	Side	Front	Side	Front	Side	Front	Side	Front	Side	Front	Side
2100 mm 6'11"	kg lb	5520* 12,172	5520* 12,172	8500* 18,743	6260 13,803	5530 12,194	3390 7475	3430 7563	2120 4675	—	—	2240* 4939	1660 3660
2500 mm 8'2"	kg lb	5420* 11,951	5420* 11,951	8480* 18,698	6420 14,156	5520 12,172	3460 7629	3480 7673	2180 4807	—	—	1800 3969	1530 3374
3000 mm 9'10"	kg lb	5980* 13,186	5980* 13,186	8380* 18,478	6550 14,443	5450 12,017	3490 7695	3500 7718	2210 4873	2370 5226	1440 3175	1500* 3308	1340 2955

\*Load limited by hydraulic capacity rather than tipping.

**313C SR ● Reach Boom ● Blade Raised**

Stick	Bucket		3 m 9'10"		4.5 m 15'0"		6 m 20'0"		At Max. Reach	
			Front	Side	Front	Side	Front	Side	Front	Side
2130 mm 7'0"	895 mm 2'11"	kg lb	5450* 9950*	4150 8850	3400 7250	2250 4750	2150 4550	1400 3000	1750 3800	1150 2500

**313C SR ● Reach Boom ● Blade Lowered**

Stick	Bucket		3 m 9'10"		4.5 m 15'0"		6 m 20'0"		At Max. Reach	
			Front	Side	Front	Side	Front	Side	Front	Side
2130 mm 7'0"	895 mm 2'11"	kg lb	5450* 9950*	4750 9950*	4950* 10,700*	2500 5400	3550* 7650*	1600 3400	2200* 4800*	1300 2800

**313C CR ● Reach Boom**

Stick	Bucket		3 m 9'10"		4.5 m 15'0"		6 m 20'0"		7.5 m 25'0"		At Max. Reach	
			Front	Side	Front	Side	Front	Side	Front	Side	Front	Side
2500 mm 8'2"	895 mm 2'11"	kg lb	4400* 9900*	4300 9200	3600 7700	2250 4850	2300 4850	1450 3100	1600 3450	1000 2150	1500 3300	950 2000
3000 mm 9'10"	700 mm 2'4"	kg lb	5000* 11,000*	4300 9150	3600 7750	2300 4950	2300 4900	1450 3100	1600 3400	1000 2100	1350 3000	850 1800

**314D CR ● Reach Boom**

Stick	Bucket		3 m 9'10"		4.5 m 15'0"		6 m 20'0"		7.5 m 25'0"		At Max. Reach	
			Front	Side	Front	Side	Front	Side	Front	Side	Front	Side
2500 mm 8'2"	910 mm 3'0"	kg lb	—	—	4250 9100	2750 5950	2700 5800	1800 3800	—	—	1900* 4100*	1300 2800
2800 mm 9'2"	760 mm 2'6"	kg lb	5000* 11,650*	5000* 11,150	4250 9150	2800 5950	2700 5800	1800 3800	—	—	1850* 4100*	1200 2650
3000 mm 9'10"	760 mm 2'6"	kg lb	5300* 12,350*	5200 11,150	4250 9150	2800 5950	2700 5800	1800 3800	1900 4050	1250 2600	1700* 3700*	1150 2500

**314D LCR ● Reach Boom**

Stick	Bucket		3 m 9'10"		4.5 m 15'0"		6 m 20'0"		7.5 m 25'0"		At Max. Reach	
			Front	Side	Front	Side	Front	Side	Front	Side	Front	Side
2500 mm 8'2"	910 mm 3'0"	kg lb	—	—	4900 10,550	2800 6000	3100 6650	1800 3850	—	—	1900* 4100*	1300 2800
2800 mm 9'2"	760 mm 2'6"	kg lb	5000* 11,650*	5000* 11,250	4950 10,600	2800 6050	3150 6700	1800 3850	—	—	1850* 4100*	1250 2650
3000 mm 9'10"	760 mm 2'6"	kg lb	5300* 12,350*	5250 11,250	4950 10,600	2800 6050	3100 6700	1800 3850	2200 4700	1250 2650	1700* 3700*	1150 2550

\*Load limited by hydraulic capacity rather than tipping.



# Excavators

## Lifting Capacity At Ground Level

- 315D L ● 319D L

### 315D L ● Reach Boom

Stick	Bucket	3 m 9'10"		4.5 m 15'0"		6 m 20'0"		7.5 m 25'0"		At Max. Reach		
		Front	Side	Front	Side	Front	Side	Front	Side	Front	Side	
2250 mm 7'5"	922 mm 3'0"	kg 12,943	5870* 12,943	5870* 12,943	7320 16,141	4280 9437	4710 10,386	2870 6328	—	—	3430 7563	2180 4807
2600 mm 8'6"	922 mm 3'0"	kg 14,024	6360* 14,024	6360* 14,024	7340 16,185	4290 9459	4720 10,408	2870 6328	3390 7475	2070 4564	2880* 6350	2030 4476
2900 mm 9'6"	922 mm 3'0"	kg 15,810	7170* 15,810	7170* 15,810	7310 16,119	4260 9393	4690 10,341	2830 6240	3360 7409	2040 4498	2750* 6064	1920 4234
3100 mm 10'2"	922 mm 3'0"	kg 16,339	7410* 16,339	7410* 16,339	7340 16,185	4290 9459	4700 10,364	2840 6262	3360 7409	2040 4498	2500* 5513	1840 4057

### 315D L ● VA Boom

Stick	Bucket	1.5 m 5'0"		3 m 9'10"		4.5 m 15'0"		6 m 20'0"		7.5 m 25'0"		At Max. Reach		
		Front	Side	Front	Side	Front	Side	Front	Side	Front	Side	Front	Side	
2250 mm 7'5"	922 mm 3'0"	kg 15,038	6820* 15,038	6820* 15,038	13 840* 30,517	8480 18,698	7830 17,265	4680 10,319	4970 10,959	3070 6769	3460 7629	2120 4675	3450 7607	2120 4675
2600 mm 8'6"	922 mm 3'0"	kg 14,619	6630* 14,619	6630* 14,619	13 610* 30,010	8590 18,941	7850 17,309	4730 10,430	5010 11,047	3110 6858	3470 7651	2130 4697	3040* 6703	1980 4366
2900 mm 9'6"	922 mm 3'0"	kg 15,192	6890* 15,192	6890* 15,192	13 310 29,349	8640 19,051	7790 17,177	4740 10,452	5010 11,047	3110 6858	3460 7629	2110 4653	2880* 6350	1870 4123
3100 mm 10'2"	922 mm 3'0"	kg 15,148	6870* 15,148	6870* 15,148	13 230* 29,172	8750 19,294	7800 17,199	4780 10,540	5010 11,047	3130 6902	3470 7651	2130 4697	2630* 5799	1800 3969

### France Sourced

#### 319D L ● 600 mm (24") Track Shoes ● with Quick Coupler/without Bucket

Stick		3 m 9'10"		4.5 m 15'0"		6 m 20'0"		7.5 m 25'0"		At Max. Reach	
		Front	Side	Front	Side	Front	Side	Front	Side	Front	Side
2250 mm 7'5"	kg lb	—	—	9530* 21,014	5030 11,091	6180 13,627	3360 7409	—	—	4510 9945	2500 5513
2700 mm 8'10"	kg lb	6210* 13,693	6210* 13,693	9370* 20,661	5090 11,223	6220 13,715	3390 7475	4440 9790	2470 5446	3650* 8048	2300 5072

#### 319D L ● 600 mm (24") Track Shoes ● with Quick Coupler/without Bucket ● VA Boom

Stick		1.5 m 5'0"		3 m 9'10"		4.5 m 15'0"		6 m 20'0"		7.5 m 25'0"		At Max. Reach	
		Front	Side	Front	Side	Front	Side	Front	Side	Front	Side	Front	Side
2250 mm 7'5"	kg lb	12 270* 27,055	12 270* 27,055	14 840* 32,722	10 530 23,219	9560* 21,080	5610 12,370	6420 14,156	3500 7718	—	—	4600 10,143	2500 5513
2700 mm 8'10"	kg lb	11 400* 25,137	11 400* 25,137	14 420* 31,796	10 810 23,836	9560* 21,080	5730 12,635	6510 14,355	3620 7982	4460 9834	2440 5380	3610* 7960	2290 5049

\*Load limited by hydraulic capacity rather than tipping.

**France Sourced**

**319D LN ● 500 mm (20") Track Shoes ● 259 kg (571 lb) Quick Coupler ● One-Piece Boom**

Stick		3 m 9'10"		4.5 m 15'0"		6 m 20'0"		7.5 m 25'0"		At Max. Reach	
		Front	Side	Front	Side	Front	Side	Front	Side	Front	Side
1850 mm 5'10"	kg lb	—	—	9570* 21,102	4330 9548	6060 13,362	2920 6439	—	—	4840 10,672	2380 5248
2250 mm 7'5"	kg lb	—	—	9530* 21,014	4400 9702	6090 13,428	2960 6527	—	—	4440 9790	2200 4851
2700 mm 8'10"	kg lb	6210* 13,693	6210* 13,693	9370* 20,661	4450 9812	6130 13,517	2990 6593	4370 9636	2170 4785	3650 8048	2020 4454
3200 mm 10'6"	kg lb	—	—	9570* 21,102	4550 10,033	6270 13,825	3070 6769	—	—	5020 11,069	2510 5535

**319D LN ● 500 mm (20") Track Shoes ● 259 kg (571 lb) Quick Coupler ● VA Boom**

Stick		1.5 m 5'0"		3 m 9'10"		4.5 m 15'0"		6 m 20'0"		7.5 m 25'0"		At Max. Reach	
		Front	Side	Front	Side	Front	Side	Front	Side	Front	Side	Front	Side
1850 mm 5'10"	kg lb	13 400* 29,547	13 400* 29,547	14 840* 32,722	8850 19,514	9550* 21,058	4840 10,672	6200 13,671	2970 6549	—	—	4960 10,937	2370 5226
2250 mm 7'5"	kg lb	12 270* 27,055	12 270* 27,055	14 480* 31,928	9090 20,043	9560* 21,080	4950 10,915	6330 13,958	3090 6813	—	—	4540 10,011	2190 4829
2700 mm 8'10"	kg lb	11 400* 25,137	11 400* 25,137	14 420* 31,796	9350 20,617	9560* 21,080	5060 11,157	6420 14,156	3200 7056	4390 9680	2130 4697	3610* 7960	2000 4410

\*Load limited by hydraulic capacity rather than tipping.

# Excavators

## Lifting Capacity At Ground Level

- M313D
- One-Piece Boom
- Quick Coupler

### M313D ● Rear Dozer Up

Stick		3 m 9'10"		4.5 m 15'0"		6 m 20'0"		7.5 m 25'0"		At Max. Reach	
		Front	Side	Front	Side	Front	Side	Front	Side	Front	Side
2000 mm 6'7"	kg lb	—	—	4900 10,805	2900 6395	3200 7056	1900 4190	—	—	2300* 5071*	1400 3087
2300 mm 7'7"	kg lb	4300* 9482*	4300* 9482*	4900 10,805	2900 6395	3200 7056	1900 4190	—	—	2100* 4631*	1300 2867
2600 mm 8'6"	kg lb	4600* 10,143*	4600* 10,143*	4800 10,573	2900 6395	3100 6836	1900 4190	2300 5072	1400 3087	1800* 3969*	1200 2646

### M313D ● Rear Dozer Down

Stick		3 m 9'10"		4.5 m 15'0"		6 m 20'0"		7.5 m 25'0"		At Max. Reach	
		Front	Side	Front	Side	Front	Side	Front	Side	Front	Side
2000 mm 6'7"	kg lb	—	—	6700* 14,774*	3400 7497	4800* 10,584*	2200 4851	—	—	2300* 5071*	1700 3749
2300 mm 7'7"	kg lb	4300* 9482*	4300* 9482*	6700* 14,774*	3400 7497	4800* 10,584*	2200 4851	—	—	2100* 4631*	1600 3528
2600 mm 8'6"	kg lb	4600* 10,143*	4600* 10,143*	6700* 14,774*	3400 7497	4800* 10,584*	2200 4851	2600* 5733*	1600 3528	1800* 3969*	1500 3308

### M313D ● Rear Stabilizer Down

Stick		3 m 9'10"		4.5 m 15'0"		6 m 20'0"		7.5 m 25'0"		At Max. Reach	
		Front	Side	Front	Side	Front	Side	Front	Side	Front	Side
2000 mm 6'7"	kg lb	—	—	6700* 14,774*	4200 9261	4500 9923	2800 6174	—	—	2300* 5071*	2000 4410
2300 mm 7'7"	kg lb	4300* 9482*	4300* 9482*	6700* 14,774*	4200 9261	4500 9923	2800 6174	—	—	2100* 4631*	1900 4190
2600 mm 8'6"	kg lb	4600* 10,143*	4600* 10,143*	6700* 14,774*	4200 9261	4500 9923	2800 6174	2600* 5733*	2000 4410	1800* 3969*	1800* 3969*

### M313D ● 4-Point Stabilizers Down

Stick		3 m 9'10"		4.5 m 15'0"		6 m 20'0"		7.5 m 25'0"		At Max. Reach	
		Front	Side	Front	Side	Front	Side	Front	Side	Front	Side
2000 mm 6'7"	kg lb	—	—	6700* 14,774*	6600 14,553	4800* 10,584*	4200 9261	—	—	2300* 5071*	2300* 5071*
2300 mm 7'7"	kg lb	4300* 9482*	4300* 9482*	6700* 14,774*	6600 14,553	4800* 10,584*	4200 9261	—	—	2100* 4631*	2100* 4631*
2600 mm 8'6"	kg lb	4600* 10,143*	4600* 10,143*	6700* 14,774*	6600 14,553	4800* 10,584*	4200 9261	2600* 5733*	2600* 5733*	1800* 3969*	1800* 3969*

### M313D ● Dozer and Stabilizer Down

Stick		3 m 9'10"		4.5 m 15'0"		6 m 20'0"		7.5 m 25'0"		At Max. Reach	
		Front	Side	Front	Side	Front	Side	Front	Side	Front	Side
2000 mm 6'7"	kg lb	—	—	6700* 14,774*	5300 11,687	4800* 10,584*	3400 7497	—	—	2300* 5071*	2300* 5071*
2300 mm 7'7"	kg lb	4300* 9482*	4300* 9482*	6700* 14,774*	5300 11,687	4800* 10,584*	3400 7497	—	—	2100* 4631*	2100* 4631*
2600 mm 8'6"	kg lb	4600* 10,143*	4600* 10,143*	6700* 14,774*	5300 11,687	4800* 10,584*	3400 7497	2600* 5733*	2500 5513	1800* 3969*	1800* 3969*

\*Load limited by hydraulic capacity rather than tipping.

**M313D ● Rear Dozer Up**

Stick		3 m 9'10"		4.5 m 15'0"		6 m 20'0"		7.5 m 25'0"		At Max. Reach	
		Front	Side	Front	Side	Front	Side	Front	Side	Front	Side
2000 mm 6'7"	kg lb	10 200 22,491	5900 13,010	5300 11,687	3300 7277	3300 7277	2000 4410	—	—	2200 4851	1300 2867
2300 mm 7'7"	kg lb	10 000* 22,050*	6000 13,230	5300 11,687	3300 7277	3300 7277	2100 4631	2300 5072	1300 2867	2100 4631	1200 2646
2600 mm 8'6"	kg lb	9800* 21,609*	6000 13,230	5200* 11,466*	3300 7277	3400 7497	2100 4631	2300 5072	1300 2867	1900* 4189*	1100 2426

**M313D ● Rear Dozer Down**

Stick		3 m 9'10"		4.5 m 15'0"		6 m 20'0"		7.5 m 25'0"		At Max. Reach	
		Front	Side	Front	Side	Front	Side	Front	Side	Front	Side
2000 mm 6'7"	kg lb	10 200* 22,491*	7000 15,435	6600* 14,553*	3800 8379	4800* 10,584*	2400 5292	—	—	2500* 5513*	1500 3308
2300 mm 7'7"	kg lb	10 000* 22,050*	7100 15,656	6600* 14,553*	3800 8379	4800* 10,584*	2400 5292	3000* 6615*	1600 3528	2200* 4851*	1400 3087
2600 mm 8'6"	kg lb	9800* 21,609*	7100* 15,656*	6500* 14,333*	3800 8379	4700* 10,364*	2400 5292	3500* 7718*	1600 3528	1900* 4189*	1300 2867

**M313D ● Rear Stabilizer Down**

Stick		3 m 9'10"		4.5 m 15'0"		6 m 20'0"		7.5 m 25'0"		At Max. Reach	
		Front	Side	Front	Side	Front	Side	Front	Side	Front	Side
2000 mm 6'7"	kg lb	10 200* 22,491*	8900* 19,625*	6600* 14,553*	4700 10,364	4700 10,364	2900 6395	—	—	2500* 5513*	1900* 4189*
2300 mm 7'7"	kg lb	10 000* 22,050*	8900 19,625	6600* 14,553*	4700 10,364	4600* 10,143*	3300 7277	3000* 6615*	2000 4410	2200* 4851*	1800 3969
2600 mm 8'6"	kg lb	9800* 21,609*	8800 19,404	6500* 14,333*	4700 10,364	4600* 10,143*	3000 6615	3200 7056	2000 4410	1900* 4189*	1700 3749

**M313D ● 4-Point Stabilizers Down**

Stick		3 m 9'10"		4.5 m 15'0"		6 m 20'0"		7.5 m 25'0"		At Max. Reach	
		Front	Side	Front	Side	Front	Side	Front	Side	Front	Side
2000 mm 6'7"	kg lb	10 200* 22,491*	10 200* 22,491*	6600* 14,553*	6600* 14,553*	4800* 10,584*	4300 9482	—	—	2500* 5513*	2500* 5513*
2300 mm 7'7"	kg lb	10 000* 22,050*	10 000* 22,050*	6600* 14,553*	6600* 14,553*	4800* 10,584*	4400 9702	3000* 6615*	3000 6615	2200* 4851*	2200* 4851*
2600 mm 8'6"	kg lb	9800* 21,609*	9800* 21,609*	6500* 14,333*	6500* 14,333*	4700* 10,364*	4400 9702	3500* 7718*	3000 6615	1900* 4189*	1900* 4189*

**M313D ● Dozer and Stabilizer Down**

Stick		3 m 9'10"		4.5 m 15'0"		6 m 20'0"		7.5 m 25'0"		At Max. Reach	
		Front	Side	Front	Side	Front	Side	Front	Side	Front	Side
2000 mm 6'7"	kg lb	10 200* 22,491*	10 200* 22,491	6600* 14,553*	5700* 12,569*	4800* 10,584*	3600 7938	—	—	2500* 5513*	2400 5292
2300 mm 7'7"	kg lb	10 000* 22,050*	10 000* 22,050*	6600* 14,553*	5700 12,569	4800* 10,584*	3600 7938	3000* 6615*	2500 5513	2200* 4851*	2200* 4851*
2600 mm 8'6"	kg lb	9800* 21,609*	9800* 21,609*	6500* 14,333*	5600 12,348	4700* 10,364*	3600 7938	3500* 7718*	2500 5513	1900* 4189*	1900* 4189*

\*Load limited by hydraulic capacity rather than tipping.

**M315D ● Rear Dozer Up**

Stick		3 m 9'10"		4.5 m 15'0"		6 m 20'0"		7.5 m 25'0"		At Max. Reach	
		Front	Side	Front	Side	Front	Side	Front	Side	Front	Side
2100 mm 6'11"	kg lb	—	—	5700 12,569	3300 7277	3700 8159	2200 4851	—	—	2500 5513	1500 3308
2400 mm 7'10"	kg lb	4000* 8820*	4000* 8820*	5600 12,348	3200 7056	3700 8159	2200 4851	2600 5733	1600 3528	2400 5292	1400 3087
2600 mm 8'6"	kg lb	4200* 9261*	4200* 9261*	5700 12,569	3300 7277	3700 8159	2200 4851	2600 5733	1600 3528	2300 5072	1400 3087

**M315D ● Rear Dozer Down**

Stick		3 m 9'10"		4.5 m 15'0"		6 m 20'0"		7.5 m 25'0"		At Max. Reach	
		Front	Side	Front	Side	Front	Side	Front	Side	Front	Side
2100 mm 6'11"	kg lb	—	—	7900* 17,419*	3800 8379	5700* 12,569*	2500 5513	—	—	2900* 6395*	1800 3969
2400 mm 7'10"	kg lb	4000* 8820*	4000* 8820*	7900* 17,419*	3800 8379	5700* 12,569*	2500 5513	4000 8820	1800 3969	2600* 5733*	1700 3749
2600 mm 8'6"	kg lb	4200* 9261*	4200* 9261*	7900* 17,419*	3800 8379	5700* 12,569*	2500 5513	4000 8820	1800 3969	2400* 5292*	1600 3528

**M315D ● Rear Stabilizer Down**

Stick		3 m 9'10"		4.5 m 15'0"		6 m 20'0"		7.5 m 25'0"		At Max. Reach	
		Front	Side	Front	Side	Front	Side	Front	Side	Front	Side
2100 mm 6'11"	kg lb	—	—	7900* 17,419*	4800 10,584	5100 11,246	3100 6836	—	—	2900* 6395*	2200 4851
2400 mm 7'10"	kg lb	4000* 8820*	4000* 8820*	7900* 17,419*	4800 10,584	5100 11,246	3100 6836	3600 7938	2300 5072	2600* 5733*	2100 4631
2600 mm 8'6"	kg lb	4200* 9261*	4200* 9261*	7900* 17,419*	4800 10,584	5100 11,246	3100 6836	3600 7938	2300 5072	2400* 5292*	2000 4410

**M315D ● 4-Point Stabilizers Down**

Stick		3 m 9'10"		4.5 m 15'0"		6 m 20'0"		7.5 m 25'0"		At Max. Reach	
		Front	Side	Front	Side	Front	Side	Front	Side	Front	Side
2100 mm 6'11"	kg lb	—	—	7900* 17,419*	7300 16,097	5700* 12,569*	4700 10,364	—	—	2900* 6395*	2900* 6395*
2400 mm 7'10"	kg lb	4000* 8820*	4000* 8820*	7900* 17,419*	7300 16,097	5700* 12,569*	4600 10,143	4200* 9261*	3300 7277	2600* 5733*	2600* 5733*
2600 mm 8'6"	kg lb	4200* 9261*	4200* 9261*	7900* 17,419*	7300 16,097	5700* 12,569*	4600 10,143	4400* 9702*	3300 7277	2400* 5292*	2400* 5292*

**M315D ● Dozer and Stabilizer Down**

Stick		3 m 9'10"		4.5 m 15'0"		6 m 20'0"		7.5 m 25'0"		At Max. Reach	
		Front	Side	Front	Side	Front	Side	Front	Side	Front	Side
2100 mm 6'11"	kg lb	—	—	7900* 17,419*	5900 13,010	5700* 12,569*	3800 8379	—	—	2900* 6395*	2700 5954
2400 mm 7'10"	kg lb	4000* 8820*	4000* 8820*	7900* 17,419*	5900 13,010	5700* 12,569*	3800 8379	4200* 9261*	2800 6174	2600* 5733*	2500 5513
2600 mm 8'6"	kg lb	4200* 9261*	4200* 9261*	7900* 17,419*	5900 13,010	5700* 12,569*	3800 8379	4400* 9702*	2800 6174	2400* 5292*	2400* 5292*

\*Load limited by hydraulic capacity rather than tipping.

**M315D ● Rear Dozer Up**

Stick		3 m 9'10"		4.5 m 15'0"		6 m 20'0"		7.5 m 25'0"		At Max. Reach	
		Front	Side	Front	Side	Front	Side	Front	Side	Front	Side
2100 mm 6'11"	kg lb	11 800* 26,019*	6600 14,553	6300 13,892	3800 8379	3900 8600	2400 5292	2600 5733	1500 3308	2400 5292	1400 3087
2400 mm 7'10"	kg lb	11 600* 25,578*	6900 15,215	6200 13,671	3800 8379	4000 8820	2400 5292	2600 5733	1500 3308	2300 5072	1300 2867
2600 mm 8'6"	kg lb	11 200* 24,696*	6900 15,215	6200 13,671	3800 8379	4000 8820	2500 5513	2700 5954	1600 3528	2200 4851	1300 2867

**M315D ● Rear Dozer Down**

Stick		3 m 9'10"		4.5 m 15'0"		6 m 20'0"		7.5 m 25'0"		At Max. Reach	
		Front	Side	Front	Side	Front	Side	Front	Side	Front	Side
2100 mm 6'11"	kg lb	11 800* 26,019*	7900 17,420	7900* 17,420*	4400 9702	5700* 12,569*	2700 5954	4000* 8820*	1800 3969	2900* 6395*	1700 3749
2400 mm 7'10"	kg lb	11 600* 25,578*	8100 17,861	7800* 17,199*	4400 9702	5600* 12,348*	2800 6174	4100 9041	1800 3969	2500* 5513*	1500 3308
2600 mm 8'6"	kg lb	11 200* 24,696*	8200 18,081	7800* 17,199*	4400 9702	5600* 12,348*	2800 6174	4100 9041	1800 3969	2300* 5072*	1500 3308

**M315D ● Rear Stabilizer Down**

Stick		3 m 9'10"		4.5 m 15'0"		6 m 20'0"		7.5 m 25'0"		At Max. Reach	
		Front	Side	Front	Side	Front	Side	Front	Side	Front	Side
2100 mm 6'11"	kg lb	11 800* 26,019*	10 200 22,491	7900* 17,420*	5400 11,907	5400 11,907	3400 7497	3600 7938	2200 4851	2900* 6395*	2100 4631
2400 mm 7'10"	kg lb	11 600* 25,578*	10 100* 22,271*	7800* 17,199*	5400 11,907	5300 11,687	3400 7497	3600 7938	2300 5072	2500* 5513*	1900 4190
2600 mm 8'6"	kg lb	11 200* 24,696*	10 100 22,271	7800* 17,199*	5400 11,907	5300 11,687	3500 7718	3700 8159	2300 5072	2300* 5072*	1900 4190

**M315D ● 4-Point Stabilizers Down**

Stick		3 m 9'10"		4.5 m 15'0"		6 m 20'0"		7.5 m 25'0"		At Max. Reach	
		Front	Side	Front	Side	Front	Side	Front	Side	Front	Side
2100 mm 6'11"	kg lb	11 800* 26,019*	11 800* 26,019*	7900* 17,420*	7600 16,758	5700* 12,569*	4900 10,805	4000* 8820*	3300 7277	2900* 6395*	2900* 6395*
2400 mm 7'10"	kg lb	11 600* 25,578*	11 600* 25,578*	7800* 17,199*	7500* 16,538*	5600* 12,348*	5000 11,025	4300* 9482*	3300 7277	2500* 5513*	2500* 5513*
2600 mm 8'6"	kg lb	11 200* 24,696*	11 200* 24,696*	7800* 17,199*	7500 16,538	5600* 12,348*	5000 11,025	4300* 9482*	3400 7497	2300* 5072*	2300* 5072*

**M315D ● Dozer and Stabilizer Down**

Stick		3 m 9'10"		4.5 m 15'0"		6 m 20'0"		7.5 m 25'0"		At Max. Reach	
		Front	Side	Front	Side	Front	Side	Front	Side	Front	Side
2100 mm 6'11"	kg lb	11 800* 26,019*	11 800* 26,019*	7900* 17,420*	6400 14,112	5700* 12,569*	4100 9041	4000* 8820*	2800 6174	2900* 6395*	2500 5513
2400 mm 7'10"	kg lb	11 600* 25,578*	11 600* 25,578*	7800* 17,199*	6400* 14,112*	5600* 12,348*	4100 9041	4300 9482	2800 6174	2500* 5513*	2400 5292
2600 mm 8'6"	kg lb	11 200* 24,696*	11 200* 24,696*	7800* 17,199*	6400 14,112	5600* 12,348*	4200 9261	4300* 9482*	2800 6174	2300* 5072*	2300 5072

\*Load limited by hydraulic capacity rather than tipping.

**M316D ● Rear Dozer Up**

Stick		3 m 9'10"		4.5 m 15'0"		6 m 20'0"		7.5 m 25'0"		At Max. Reach	
		Front	Side	Front	Side	Front	Side	Front	Side	Front	Side
2100 mm 6'11"	kg lb	—	—	6400 14,112	3700 8159	4200 9261	2500 5513	—	—	2900* 6395*	1700 3749
2400 mm 7'10"	kg lb	4000* 8820*	4000* 8820*	6400 14,112	3600 7938	4100 9041	2400 5292	3000 6615	1800 3969	2600* 5733*	1600 3528
2600 mm 8'6"	kg lb	4200* 9261*	4200* 9261*	6400 14,112	3700 8159	4200 9261	2400 5292	3000 6615	1800 3969	2400* 5292*	1600 3528

**M316D ● Rear Dozer Down**

Stick		3 m 9'10"		4.5 m 15'0"		6 m 20'0"		7.5 m 25'0"		At Max. Reach	
		Rear	Side	Rear	Side	Rear	Side	Rear	Side	Rear	Side
2100 mm 6'11"	kg lb	—	—	8800* 19,404*	4200 9261	6400* 14,112*	2800 6174	—	—	2900* 6395*	2000 4410
2400 mm 7'10"	kg lb	4000* 8820*	4000* 8820*	8800* 19,404*	4200 9261	6300* 13,892*	2800 6174	4100* 9041*	2100 4631	2600* 5733*	1900 4190
2600 mm 8'6"	kg lb	4200* 9261*	4200* 9261*	8800* 19,404*	4200 9261	6300* 13,892*	2800 6174	4700 10,364	2000 4410	2400* 5292*	1800 3969

**M316D ● Rear Stabilizer Down**

Stick		3 m 9'10"		4.5 m 15'0"		6 m 20'0"		7.5 m 25'0"		At Max. Reach	
		Rear	Side	Rear	Side	Rear	Side	Rear	Side	Rear	Side
2100 mm 6'11"	kg lb	—	—	8800* 19,404*	5300 11,687	5800 12,789	3500 7718	—	—	2900* 6395*	2400 5292
2400 mm 7'10"	kg lb	4000* 8820*	4000* 8820*	8800* 19,404*	5300 11,687	5800 12,789	3500 7718	4100* 9041*	2500 5513	2600* 5733*	2300 5072
2600 mm 8'6"	kg lb	4200* 9261*	4200* 9261*	8800* 19,404*	5300 11,687	5800 12,789	3500 7718	4100 9041	2500 5513	2400* 5292*	2200 4851

**M316D ● 4-Point Stabilizers Down**

Stick		3 m 9'10"		4.5 m 15'0"		6 m 20'0"		7.5 m 25'0"		At Max. Reach	
		Front	Side	Front	Side	Front	Side	Front	Side	Front	Side
2100 mm 6'11"	kg lb	—	—	8800* 19,404*	8000 17,640	6400* 14,112*	5100 11,246	—	—	2900* 6395*	2900* 6395*
2400 mm 7'10"	kg lb	4000* 8820*	4000* 8820*	8800* 19,404*	8000 17,640	6300* 13,892*	5100 11,246	4100* 9041*	3700 8159	2600* 5733*	2600* 5733*
2600 mm 8'6"	kg lb	4200* 9261*	4200* 9261*	8800* 19,404*	8000 17,640	6300* 13,892*	5100 11,246	4800* 10,584*	3700 8159	2400* 5292*	2400* 5292*

**M316D ● Dozer and Stabilizer Down**

Stick		3 m 9'10"		4.5 m 15'0"		6 m 20'0"		7.5 m 25'0"		At Max. Reach	
		Front	Side	Front	Side	Front	Side	Front	Side	Front	Side
2100 mm 6'11"	kg lb	—	—	8800* 19,404*	6600 14,553	6400* 14,112*	4300 9482	—	—	2900* 6395*	2900* 6395*
2400 mm 7'10"	kg lb	4000* 8820*	4000* 8820*	8800* 19,404*	6600 14,553	6300* 13,892*	4300 9482	4100* 9041*	3100 6836	2600* 5733*	2600* 5733*
2600 mm 8'6"	kg lb	4200* 9261*	4200* 9261*	8800* 19,404*	6600 14,553	6300* 13,892*	4300 9482	4800* 10,584*	3100 6836	2400* 5292*	2400* 5292*

\*Load limited by hydraulic capacity rather than tipping.

**M316D • Rear Dozer Up**

Stick		3 m 9'10"		4.5 m 15'0"		6 m 20'0"		7.5 m 25'0"		At Max. Reach	
		Front	Side	Front	Side	Front	Side	Front	Side	Front	Side
2100 mm 6'11"	kg lb	12 700* 28,004*	7300 16,097	7000 15,435	4200 9261	4400 9702	2700 5954	3000 6615	1700 3749	2800 6174	1600 3528
2400 mm 7'10"	kg lb	12 500* 27,563*	7600 16,758	6900 15,215	4200 9261	4400 9702	2700 5954	3000 6615	1800 3969	2500* 5513*	1500 3308
2600 mm 8'6"	kg lb	12 200* 26,901*	7600 16,758	6900 15,215	4200 9261	4500 9923	2700 5954	3000 6615	1800 3969	2300* 5072*	1400 3087

**M316D • Rear Dozer Down**

Stick		3 m 9'10"		4.5 m 15'0"		6 m 20'0"		7.5 m 25'0"		At Max. Reach	
		Front	Side	Front	Side	Front	Side	Front	Side	Front	Side
2100 mm 6'11"	kg lb	12 700* 28,004*	8700 19,184	8700* 19,184*	4800 10,584	6300* 13,892*	3100 6836	4200* 9261*	2000 4410	2900* 6395*	1900 4190
2400 mm 7'10"	kg lb	12 500* 27,563*	8900 19,625	8600* 18,963*	4800 10,584	6200* 13,671*	3100 6836	4700* 10,364*	2000 4410	2500* 5513*	1800 3969
2600 mm 8'6"	kg lb	12 200* 26,901*	9000 19,845	8600* 18,963*	4800 10,584	6200* 13,671*	3100 6836	4800* 10,584*	2100 4631	2300* 5072*	1700 3749

**M316D • Rear Stabilizer Down**

Stick		3 m 9'10"		4.5 m 15'0"		6 m 20'0"		7.5 m 25'0"		At Max. Reach	
		Front	Side	Front	Side	Front	Side	Front	Side	Front	Side
2100 mm 6'11"	kg lb	12 700* 28,004*	11 100 24,476	8700* 19,184*	5900 13,010	6100 13,451	3700 8159	4100 9041	2500 5513	2900* 6395*	2300 5072
2400 mm 7'10"	kg lb	12 500* 27,563*	11 200 24,696	8600* 18,963*	5900 13,010	6000 13,230	3800 8379	4100 9041	2500 5513	2500* 5513*	2200 4851
2600 mm 8'6"	kg lb	12 200* 26,901*	11 100 24,476	8600* 18,963*	5900 13,010	6000 13,230	3800 8379	4200 9261	2500 5513	2300* 5072*	2100 4631

**M316D • 4-Point Stabilizers Down**

Stick		3 m 9'10"		4.5 m 15'0"		6 m 20'0"		7.5 m 25'0"		At Max. Reach	
		Front	Side	Front	Side	Front	Side	Front	Side	Front	Side
2100 mm 6'11"	kg lb	12 700* 28,004*	12 700* 28,004*	8700* 19,184*	8300 18,302	6300* 13,892*	5400 11,907	4200* 9261*	3700 8159	2900* 6395*	2900* 6395*
2400 mm 7'10"	kg lb	12 500* 27,563*	12 500* 27,563*	8600* 18,963*	8300 18,302	6200* 13,671*	5400 11,907	4700* 10,364*	3700 8159	2500* 5513*	2500* 5513*
2600 mm 8'6"	kg lb	12 200* 26,901*	12 200* 26,901*	8600* 18,963*	8200 18,081	6200* 13,671*	5500 12,128	4800* 10,584*	3700 8159	2300* 5072*	2300* 5072*

**M316D • Dozer and Stabilizer Down**

Stick		3 m 9'10"		4.5 m 15'0"		6 m 20'0"		7.5 m 25'0"		At Max. Reach	
		Front	Side	Front	Side	Front	Side	Front	Side	Front	Side
2100 mm 6'11"	kg lb	12 700* 28,004*	12 700* 28,004*	8700* 19,184*	7200 15,876	6300* 13,892*	4600 10,143	4200* 9261*	3100 6836	2900* 6395*	2900 6395
2400 mm 7'10"	kg lb	12 500* 27,563*	12 500* 27,563*	8600* 18,963*	7100 15,656	6200* 13,671*	4600 10,143	4700* 10,364*	3100 6836	2500* 5513*	2500* 5513*
2600 mm 8'6"	kg lb	12 200* 26,901*	12 200* 26,901*	8600* 18,963*	7100 15,656	6200* 13,671*	4600 10,143	4800* 10,584*	3100 6836	2300* 5072*	2300* 5072*

\*Load limited by hydraulic capacity rather than tipping.



**M318D ● Rear Dozer Up**

Stick		3 m 9'10"		4.5 m 15'0"		6 m 20'0"		7.5 m 25'0"		At Max. Reach	
		Front	Side	Front	Side	Front	Side	Front	Side	Front	Side
2200 mm 7'3"	kg lb	—	—	6600 14,553	3700 8159	4300 9482	2500 5513	3100 6836	1800 3969	2800 6174	1600 3528
2500 mm 8'2"	kg lb	—	—	6700 14,774	3800 8379	4300 9482	2500 5513	3100 6836	1800 3969	2700 5954	1600 3528
2800 mm 9'2"	kg lb	5000* 11,025*	5000* 11,025*	6600 14,553	3800 8379	4300 9482	2500 5513	3100 6836	1800 3969	2500 5513	1500 3308

**M318D ● Rear Dozer Down**

Stick		3 m 9'10"		4.5 m 15'0"		6 m 20'0"		7.5 m 25'0"		At Max. Reach	
		Front	Side	Front	Side	Front	Side	Front	Side	Front	Side
2200 mm 7'3"	kg lb	—	—	10 200* 22,491*	4300 9482	7100 15,656	2900 6395	5000 11,025	2100 4631	3800* 8379*	1900 4190
2500 mm 8'2"	kg lb	—	—	10 200* 22,491*	4400 9702	7100 15,656	2900 6395	5000 11,025	2100 4631	2900* 6395*	1800 3969
2800 mm 9'2"	kg lb	5000* 11,025*	5000* 11,025*	10 200* 22,491*	4400 9702	7100 15,656	2900 6395	5000 11,025	2100 4631	2600* 5733*	1700 3749

**M318D ● Rear Stabilizer Down**

Stick		3 m 9'10"		4.5 m 15'0"		6 m 20'0"		7.5 m 25'0"		At Max. Reach	
		Front	Side	Front	Side	Front	Side	Front	Side	Front	Side
2200 mm 7'3"	kg lb	—	—	9900 21,830	5400 11,907	6100 13,451	3600 7938	4300 9482	2600 5733	3800* 8379*	2400 5292
2500 mm 8'2"	kg lb	—	—	10 000 22,050	5500 12,128	6200 13,671	3600 7938	4400 9702	2600 5733	2900* 6395*	2200 4851
2800 mm 9'2"	kg lb	5000* 11,025*	5000* 11,025*	10 000 22,050	5500 12,128	6200 13,671	3600 7938	4300 9482	2600 5733	2600* 5733*	2100 4631

**M318D ● 4-Point Stabilizers Down**

Stick		3 m 9'10"		4.5 m 15'0"		6 m 20'0"		7.5 m 25'0"		At Max. Reach	
		Front	Side	Front	Side	Front	Side	Front	Side	Front	Side
2200 mm 7'3"	kg lb	—	—	10 200* 22,491*	8300 18,302	7400* 16,317*	5300 11,687	5700* 12,569*	3800 8379	3800* 8379*	3500 7718
2500 mm 8'2"	kg lb	—	—	10 200* 22,491*	8400 18,522	7400* 16,317*	5400 11,907	5700* 12,569*	3800 8379	2900* 6395*	2900* 6395*
2800 mm 9'2"	kg lb	5000* 11,025*	5000* 11,025*	10 200* 22,491*	8400 18,522	7300* 16,097*	5300 11,687	5700* 12,569*	3800 8379	2600* 5733*	2600* 5733*

**M318D ● Dozer and Stabilizer Down**

Stick		3 m 9'10"		4.5 m 15'0"		6 m 20'0"		7.5 m 25'0"		At Max. Reach	
		Front	Side	Front	Side	Front	Side	Front	Side	Front	Side
2200 mm 7'3"	kg lb	—	—	10 200* 22,491*	6800 14,994	7400* 16,317*	4400 9702	5700* 12,569*	3200 7056	3800* 8379*	2900 6395
2500 mm 8'2"	kg lb	—	—	10 200* 22,491*	6900 15,215	7400* 16,317*	4500 9923	5700* 12,569*	3200 7056	2900* 6395*	2800 6174
2800 mm 9'2"	kg lb	5000* 11,025*	5000* 11,025*	10 200* 22,491*	6900 15,215	7300* 16,097*	4500 9923	5700* 12,569*	3200 7056	2600* 5733*	2600* 5733*

\*Load limited by hydraulic capacity rather than tipping.

**M318D • Rear Dozer Up**

Stick		3 m 9'10"		4.5 m 15'0"		6 m 20'0"		7.5 m 25'0"		At Max. Reach	
		Front	Side	Front	Side	Front	Side	Front	Side	Front	Side
2200 mm 7'3"	kg lb	14 500 31,973	8000 17,640	7500 16,538	4400 9702	4700 10,364	2800 6174	3100 6836	1800 3969	2800 6174	1600 3528
2500 mm 8'2"	kg lb	14 500 31,973	8100 17,861	7500 16,538	4500 9923	4800 10,584	2900 6395	3200 7056	1900 4190	2700* 5954*	1500 3308
2800 mm 9'2"	kg lb	14 100 31,091	8200 18,081	7400 16,317	4500 9923	4900 10,805	3000 6615	3200 7056	1900 4190	2300* 5072*	1400 3087

**M318D • Rear Dozer Down**

Stick		3 m 9'10"		4.5 m 15'0"		6 m 20'0"		7.5 m 25'0"		At Max. Reach	
		Front	Side	Front	Side	Front	Side	Front	Side	Front	Side
2200 mm 7'3"	kg lb	15 000* 33,075*	9500 20,948	10 100* 22,271*	5100 11,246	7300* 16,097*	3300 7277	5000 11,025	2100 4631	3500* 7718*	1900 4190
2500 mm 8'2"	kg lb	14 600* 32,193*	9600 21,168	10 100* 22,271*	5200 11,466	7300* 16,097*	3400 7497	5100 11,246	2200 4851	2700* 5954*	1800 3969
2800 mm 9'2"	kg lb	14 100* 31,091*	9700 21,389	10 100* 22,271*	5200 11,466	7200* 15,876*	3400 7497	5100 11,246	2200 4851	2300* 5072*	1700 3749

**M318D • Rear Stabilizer Down**

Stick		3 m 9'10"		4.5 m 15'0"		6 m 20'0"		7.5 m 25'0"		At Max. Reach	
		Front	Side	Front	Side	Front	Side	Front	Side	Front	Side
2200 mm 7'3"	kg lb	15 000* 33,075*	12 100 26,681	10 100* 22,271*	6300 13,892	6600 14,553	4000 8820	4400 9702	2600 5733	3500* 7718*	2400 5292
2500 mm 8'2"	kg lb	14 600* 32,193*	12 100 26,681	10 100* 22,271*	6400 14,112	6600 14,553	4100 9041	4400 9702	2700 5954	2700* 5954*	2200 4851
2800 mm 9'2"	kg lb	14 100* 31,091*	12 000 26,460	10 100* 22,271*	6400 14,112	6500 14,333	4100 9041	4500 9923	2700 5954	2300* 5072*	2100 4631

**M318D • 4-Point Stabilizers Down**

Stick		3 m 9'10"		4.5 m 15'0"		6 m 20'0"		7.5 m 25'0"		At Max. Reach	
		Front	Side	Front	Side	Front	Side	Front	Side	Front	Side
2200 mm 7'3"	kg lb	15 000* 33,075*	15 000* 33,075*	10 100* 22,271*	8900 19,625	7300* 16,097*	5700 12,569	5500* 12,128*	3900 8600	3500* 7718*	3500* 7718*
2500 mm 8'2"	kg lb	14 600* 32,193*	14 600* 32,193*	10 100* 22,271*	8900 19,625	7300* 16,097*	5800 12,789	5700* 12,569*	3900* 8599*	2700* 5954*	2700* 5954*
2800 mm 9'2"	kg lb	14 100* 31,091*	14 100* 31,091*	10 100* 22,271*	8900 19,625	7300* 16,097*	5800 12,789	5700* 12,569*	3900 8600	2300* 5072*	2300* 5072*

**M318D • Dozer and Stabilizer Down**

Stick		3 m 9'10"		4.5 m 15'0"		6 m 20'0"		7.5 m 25'0"		At Max. Reach	
		Front	Side	Front	Side	Front	Side	Front	Side	Front	Side
2200 mm 7'3"	kg lb	15 000* 33,075*	14 800 32,634	10 100* 22,271*	7600 16,758	7300* 16,097*	4900 10,805	5500* 12,128*	3200 7056	3500* 7718*	2900 6395
2500 mm 8'2"	kg lb	14 600* 32,193*	14 600* 32,193*	10 100* 22,271*	7600 16,758	7300* 16,097*	4900 10,805	5700* 12,569*	3300 7277	2700* 5954*	2700* 5954*
2800 mm 9'2"	kg lb	14 100* 31,091*	14 100* 31,091*	10 100* 22,271*	7600 16,758	7300* 16,097*	5000 11,025	5700* 12,569*	3300 7277	2300* 5072*	2300* 5072*

\*Load limited by hydraulic capacity rather than tipping.

**M322D ● Rear Dozer Up**

Stick		3 m 9'10"		4.5 m 15'0"		6 m 20'0"		7.5 m 25'0"		At Max. Reach	
		Front	Side	Front	Side	Front	Side	Front	Side	Front	Side
2200 mm 7'3"	kg lb	—	—	7200 15,876	4400 9702	4700 10,364	2900 6395	3400 7497	2100 4631	2800 6174	1800 3969
2500 mm 8'2"	kg lb	—	—	7200 15,876	4400 9702	4700 10,364	2900 6395	3400 7497	2100 4631	2600* 5733*	1700 3749
2900 mm 9'6"	kg lb	—	—	7200 15,876	4400 9702	4700 10,364	2900 6395	3400 7497	2100 4631	2200* 4851*	1500 3308

**M322D ● Rear Dozer Down**

Stick		3 m 9'10"		4.5 m 15'0"		6 m 20'0"		7.5 m 25'0"		At Max. Reach	
		Front	Side	Front	Side	Front	Side	Front	Side	Front	Side
2200 mm 7'3"	kg lb	—	—	11 800* 26,019*	5100 11,246	8500 18,743	3400 7497	5900 13,010	2500 5513	2900* 6395*	2000 4410
2500 mm 8'2"	kg lb	—	—	11 900* 26,240*	5100 11,246	8500 18,743	3400 7497	5900 13,010	2500 5513	2600* 5733*	1900 4190
2900 mm 9'6"	kg lb	—	—	11 800* 26,019*	5100 11,246	8500* 18,743*	3400 7497	5800 12,789	2400 5292	2200* 4851*	1800 3969

**M322D ● Rear Stabilizer Down**

Stick		3 m 9'10"		4.5 m 15'0"		6 m 20'0"		7.5 m 25'0"		At Max. Reach	
		Front	Side	Front	Side	Front	Side	Front	Side	Front	Side
2200 mm 7'3"	kg lb	—	—	11 800* 26,019*	6400 14,112	7300 16,097	4200 9261	5100 11,246	3100 6836	2900* 6395*	2500 5513
2500 mm 8'2"	kg lb	—	—	11 900* 26,240*	6400 14,112	7300 16,097	4200 9261	5100 11,246	3100 6836	2600* 5733*	2400 5292
2900 mm 9'6"	kg lb	—	—	11 800* 26,019*	6400 14,112	7300 16,097	4200 9261	5100 11,246	3000 6615	2200* 4851*	2200 4851

**M322D ● 4-Point Stabilizers Down**

Stick		3 m 9'10"		4.5 m 15'0"		6 m 20'0"		7.5 m 25'0"		At Max. Reach	
		Front	Side	Front	Side	Front	Side	Front	Side	Front	Side
2200 mm 7'3"	kg lb	—	—	11 800* 26,019*	10 100 22,271	8600* 18,963*	6400 14,112	6600* 14,553*	4600 10,143	2900* 6395*	2900* 6395*
2500 mm 8'2"	kg lb	—	—	11 900* 26,240*	10 100 22,271	8600* 18,963*	6400 14,112	6600* 14,553*	4600 10,143	2600* 5733*	2600* 5733*
2900 mm 9'6"	kg lb	—	—	11 800* 26,019*	10 100 22,271	8500* 18,743*	6200 13,671	6600* 14,553*	4500 9923	2200* 4851*	2200* 4851*

**M322D ● Dozer and Stabilizer Down**

Stick		3 m 9'10"		4.5 m 15'0"		6 m 20'0"		7.5 m 25'0"		At Max. Reach	
		Front	Side	Front	Side	Front	Side	Front	Side	Front	Side
2200 mm 7'3"	kg lb	—	—	11 800* 26,019*	8300 18,302	8600* 18,963*	5400 11,907	6600* 14,553*	3900 8600	2900* 6395*	2900* 6395*
2500 mm 8'2"	kg lb	—	—	11 900* 26,240*	8300 18,302	8600* 18,963*	5400 11,907	6600* 14,553*	3900 8600	2600* 5733*	2600* 5733*
2900 mm 9'6"	kg lb	—	—	11 800* 26,019*	8300 18,302	8500* 18,743*	5400 11,907	6600* 14,553*	3800 8379	2200* 4851*	2200* 4851*

\*Load limited by hydraulic capacity rather than tipping.

**M322D ● Rear Dozer Up**

Stick		3 m 9'10"		4.5 m 15'0"		6 m 20'0"		7.5 m 25'0"		At Max. Reach	
		Front	Side	Front	Side	Front	Side	Front	Side	Front	Side
2200 mm 7'3"	kg lb	16 100 35,501	9500 20,948	8300 18,302	5300 11,687	5300 11,687	3500 7718	3500 7718	2200 4851	2700* 5954*	1800 3969
2500 mm 8'2"	kg lb	16 100 35,501	9800 21,609	8300 18,302	5400 11,907	5300 11,687	3500 7718	3500 7718	5300 11,687	2500* 5513*	1700 3749
2900 mm 9'6"	kg lb	15 800 34,839	9900 21,830	8200 18,081	5400 11,907	5400 11,907	3500 7718	3600 7938	2300 5072	2100* 4631*	1500 3308

**M322D ● Rear Dozer Down**

Stick		3 m 9'10"		4.5 m 15'0"		6 m 20'0"		7.5 m 25'0"		At Max. Reach	
		Front	Side	Front	Side	Front	Side	Front	Side	Front	Side
2200 mm 7'3"	kg lb	16 700* 36,825*	11 300 24,917	11 800* 26,019*	6100 13,451	8500* 18,743*	4000 8820	6100 13,451	2600 5733	2700* 5954*	2100 4631
2500 mm 8'2"	kg lb	16 400* 36,162*	11 600 25,578	11 800* 26,019*	6200 13,671	8500* 18,743*	4000 8820	6100 13,451	2600 5733	2500* 5513*	2000 4410
2900 mm 9'6"	kg lb	15 800* 34,839*	11 700 25,799	11 700* 25,799*	6200 13,671	8400* 18,522*	4000 8820	6100 13,451	2700 5954	2100* 4631*	1800 3969

**M322D ● Rear Stabilizer Down**

Stick		3 m 9'10"		4.5 m 15'0"		6 m 20'0"		7.5 m 25'0"		At Max. Reach	
		Front	Side	Front	Side	Front	Side	Front	Side	Front	Side
2200 mm 7'3"	kg lb	16 700* 36,825*	16 700 36,824	11 800* 26,019*	10 800 23,814	8500 18,743	7100 15,656	6700 14,774	4700 10,364	2700* 5954*	2700 5954
2500 mm 8'2"	kg lb	16 400* 36,162*	14 600 32,193	11 800* 26,019*	7600 16,758	7800 17,199	4900 10,805	5300 11,687	6200 13,671	2500* 5513*	2400 5292
2900 mm 9'6"	kg lb	15 800* 34,839*	14 400 31,752	11 700* 25,799*	7500 16,538	7700 16,979	4900 10,805	5400 11,907	3300 7277	2100* 4631*	2100* 4631*

**M322D ● 4-Point Stabilizers Down**

Stick		3 m 9'10"		4.5 m 15'0"		6 m 20'0"		7.5 m 25'0"		At Max. Reach	
		Front	Side	Front	Side	Front	Side	Front	Side	Front	Side
2200 mm 7'3"	kg lb	16 700* 36,825*	16 700* 36,825*	11 800* 26,019*	10 800 23,814	8500* 18,743*	7100 15,656	6700* 14,744*	4700 10,364	2700* 5954*	2700* 5954*
2500 mm 8'2"	kg lb	16 400* 36,162*	16 400* 36,162*	11 800* 26,019*	10 800 23,814	8500* 18,743*	7000 15,435	6600* 14,553*	4700 10,364	2500* 5513*	2500* 5513*
2900 mm 9'6"	kg lb	15 800* 34,839*	15 800* 34,839*	11 700* 25,799*	10 700 23,594	8400* 18,522*	6900 15,215	6500* 14,333*	4800 10,584	2100* 4631*	2100* 4631*

**M322D ● Dozer and Stabilizer Down**

Stick		3 m 9'10"		4.5 m 15'0"		6 m 20'0"		7.5 m 25'0"		At Max. Reach	
		Front	Side	Front	Side	Front	Side	Front	Side	Front	Side
2200 mm 7'3"	kg lb	16 700* 36,825*	16 700* 36,825*	11 800* 26,019*	9300 20,507	8500* 18,743*	6100 13,451	6700* 14,744*	4000 8820	2700* 5954*	2700* 5954*
2500 mm 8'2"	kg lb	16 400* 36,162*	16 400* 36,162*	11 800* 26,019*	9200 20,286	8500* 18,743*	6100 13,451	6600* 14,553*	4000 8820	2500* 5513*	2500* 5513*
2900 mm 9'6"	kg lb	15 800* 34,839*	15 800* 34,839*	11 700* 25,799*	9100 20,066	8500* 18,743*	6000 13,230	6500* 14,333*	4100 9041	2100* 4631*	2100* 4631*

\*Load limited by hydraulic capacity rather than tipping.

**Japan/China/Indonesia/Brazil Sourced**

**320D ● Reach Boom ● 600 mm (24") Track Shoes**

Stick	Bucket		3 m 9'10"		4.5 m 15'0"		6 m 20'0"		7.5 m 25'0"		9 m 30'0"		At Max. Reach	
			Front	Side	Front	Side	Front	Side	Front	Side	Front	Side	Front	Side
1900 mm 6'3"	B1-1370X 4'6"	kg lb	—	—	8200 17,600	4800 10,250	5150 11,100	3100 6650	3650 —	2150 —	—	—	3100 6750	1800 3950
2500 mm 8'2"	B1-1220X 4'0"	kg lb	5650* 13,000*	5650* 13,000*	8800 18,850	5350 11,450	5600 11,950	3500 7500	3950 8450	2500 5300	—	—	2950* 6500*	1900 4150
2900 mm 9'6"	B1-1100X 3'7"	kg lb	6350* 14,600*	6350* 14,600*	8900 19,050	5400 11,600	5600 12,050	3550 7600	3950 8500	2500 5350	—	—	2550* 5550*	1800 3900
3900 mm 12'10"	B1-1100X 3'7"	kg lb	7650* 17,500*	7650* 17,500*	8850 19,000	5400 11,550	5550 11,900	3450 7400	3900 8300	2400 5100	2850 6100	1700 3650	1750* 3800*	1400 3050

**320D ● Mass Boom ● 600 mm (24") Track Shoes**

Stick	Bucket		3 m 9'10"		4.5 m 15'0"		6 m 20'0"		7.5 m 25'0"		9 m 30'0"		At Max. Reach	
			Front	Side	Front	Side	Front	Side	Front	Side	Front	Side	Front	Side
2400 mm 7'10"	CB2-1370X 4'6"	kg lb	8550* 19,700*	8550* 19,700*	8600 18,400	5100 10,950	5350 11,450	3250 6950	3700 —	2200 —	—	—	3150 6950	1850 4100

**Japan Sourced**

**320D RR ● Reach Boom**

Stick	Bucket		3 m 9'10"		4.5 m 15'0"		6 m 20'0"		7.5 m 25'0"		9 m 30'0"		At Max. Reach	
			Front	Side	Front	Side	Front	Side	Front	Side	Front	Side	Front	Side
2500 mm 8'2"	B1-1220X 4'0"	kg lb	5650* 13,050*	5650* 13,050*	9500 20,350	5700 12,250	6050 12,950	3750 8050	4300 9200	2700 5750	—	—	2950* 6500*	2050 4550
2900 mm 9'6"	B1-1100X 3'7"	kg lb	6400* 14,600*	6400* 14,600*	9550 20,500	5800 12,400	6050 13,000	3800 8150	4300 9250	2700 5750	—	—	2550* 5550*	1950 4250
3900 mm 12'10"	B1-1100X 3'7"	kg lb	7650* 17,550*	7650* 17,550*	9100* 19,650*	5750 12,350	6000 12,850	3700 7950	4200 9000	2600 5550	3100 6700	1900 4000	1750* 3800*	1550 3350

\*Load limited by hydraulic capacity rather than tipping.

Japan/China/Indonesia/Brazil Sourced

320D L • Reach Boom • 800 mm (32") Track Shoes

Stick	Bucket		3 m 9'10"		4.5 m 15'0"		6 m 20'0"		7.5 m 25'0"		9 m 30'0"		At Max. Reach	
			Front	Side	Front	Side	Front	Side	Front	Side	Front	Side	Front	Side
1900 mm 6'3"	B1-1470X 4'10"	kg lb	—	—	9700* 20,900*	5700 12,250	6550 14,000	3700 7900	4600 —	2600 —	—	—	3900 8600	2200 4800
2500 mm 8'2"	B1-1280X 4'2"	kg lb	5650* 13,050*	5650* 13,050*	10 150* 21,900*	6300 13,500	6950 14,900	4100 8800	4900 10,500	2950 6250	—	—	2950* 6500*	2250 5000
2900 mm 9'6"	B1-1220X 4'0"	kg lb	6350* 14,550*	6350* 14,550*	9950* 21,500*	6350 13,600	6950 14,950	4100 8850	4900 10,500	2900 6250	—	—	2500* 5500*	2100 4600
3900 mm 12'10"	B1-1100X 3'7"	kg lb	7650* 17,550*	7650* 17,550*	9100* 19,650*	6300 13,550	6550* 14,100*	4050 8700	4850 10,350	2850 6100	3600 7650	2100 4400	1750* 3800*	1700 3700

320D L • Mass Boom • 800 mm (32") Track Shoes

Stick	Bucket		3 m 9'10"		4.5 m 15'0"		6 m 20'0"		7.5 m 25'0"		9 m 30'0"		At Max. Reach	
			Front	Side	Front	Side	Front	Side	Front	Side	Front	Side	Front	Side
2400 mm 7'10"	CB2-1470X 4'10"	kg lb	8550* 19,650*	8550* 19,650*	9700* 21,000*	6000 12,850	6700 14,300	3800 8150	4600 —	2600 —	—	—	3900* 8600*	2250 4900

Japan Sourced

320D LRR • Reach Boom • 800 mm (32") Track Shoes

Stick	Bucket		3 m 9'10"		4.5 m 15'0"		6 m 20'0"		7.5 m 25'0"		9 m 30'0"		At Max. Reach	
			Front	Side	Front	Side	Front	Side	Front	Side	Front	Side	Front	Side
2500 mm 8'2"	B1-12800X 4'2"	kg lb	5650* 13,050*	5650* 13,050*	10 150* 21,900*	6700 14,400	7300* 15,750*	4400 9450	5300 11,350	3150 6750	—	—	2950* 6500*	2450 5400
2900 mm 9'6"	B1-12200X 4'0"	kg lb	6350* 14,550*	6350* 14,550*	9950* 21,500*	6750 14,500	7150* 15,400*	4400 9450	5300 11,350	3150 6750	—	—	2500* 5500*	2250 4950
3900 mm 12'10"	B1-1100X 3'7"	kg lb	7650* 17,550*	7650* 17,550*	9100* 19,650*	6750 14,450	6550* 14,100*	4350 9350	5200* 11,200	3050 6550	3900 8050*	2250 4800	1750* 3800*	1750* 3800*

321D LCR • Reach Boom • 800 mm (32") Track Shoes

Stick	Bucket		3 m 9'10"		4.5 m 15'0"		6 m 20'0"		7.5 m 25'0"		9 m 30'0"		At Max. Reach	
			Front	Side	Front	Side	Front	Side	Front	Side	Front	Side	Front	Side
2900 mm 9'6"	B914HD 3'0"	kg lb	6950* 15,800*	6950* 15,800*	11 200* 24,150*	6300 13,500	7200 15,450*	4100 8800	5100 10,900	2900 6250	—	—	2550* 5650*	2150 4700

321D LCR • VA Boom • with Quick Coupler/without Bucket

Stick	Bucket		3 m 9'10"		4.5 m 15'0"		6 m 20'0"		7.5 m 25'0"		9 m 30'0"		At Max. Reach	
			Front	Side	Front	Side	Front	Side	Front	Side	Front	Side	Front	Side
2900 mm 9'6"	B1082HD 3'7"	kg lb	5200* 11,466*	5200* 11,466*	10 250* 22,601*	5950 13,120	7000 15,435	3950 8710	5000 11,025	2850 6284	—	—	3450* 7607*	2200 4851

\*Load limited by hydraulic capacity rather than tipping.

**Belgium/Brazil Sourced**

**323D L ● Reach Boom ● 600 mm (24") Track Shoes**

Stick		3 m 9'10"		4.5 m 15'0"		6 m 20'0"		7.5 m 25'0"		9 m 30'0"		At Max. Reach	
		Front	Side	Front	Side	Front	Side	Front	Side	Front	Side	Front	Side
1.9 m 6'3"	kg lb	—	—	10 440* 23,020*	5340 11,775	7370 16,251	3580 7894	5280 11,642	2620 5777	—	—	5170 11,400	2570 5667
2.5 m 8'2"	kg lb	6050 13,340	6050 13,340	10 530 23,219	5600 12,348	7570 16,692	3770 8313	5410 11,929	2750 6064	—	—	4320* 9526*	2420 5336
2.9 m 9'6"	kg lb	6820 15,038	6820 15,038	10 330 22,778	5640 12,436	7460* 16,449	3780 8335	5410 11,929	2750 6064	—	—	3570* 7872*	2240 4939

**323D L ● Mass Boom ● 600 mm (24") Track Shoes**

Stick		3 m 9'10"		4.5 m 15'0"		6 m 20'0"		7.5 m 25'0"		9 m 30'0"		At Max. Reach	
		Front	Side	Front	Side	Front	Side	Front	Side	Front	Side	Front	Side
1.9 m 6'3"	kg lb	—	—	10 580* 23,329*	5520 12,172	7500 16,538	3690 8136	—	—	—	—	5820 12,833	2910 6417

**Japan Sourced**

**323D L ● Reach Boom ● 600 mm (24") Track Shoes**

Stick		3 m 9'10"		4.5 m 15'0"		6 m 20'0"		7.5 m 25'0"		9 m 30'0"		At Max. Reach	
		Front	Side	Front	Side	Front	Side	Front	Side	Front	Side	Front	Side
2.5 m 8'2"	kg lb	6050* 13,340*	6050* 13,340*	10 530* 23,219*	5600 12,348	7570 16,692	3770 8313	5410 11,929	2750 6064	—	—	4320* 9526*	2420 5336
2.9 m 9'6"	kg lb	6820* 15,038*	6820* 15,038*	10 330* 22,778*	5640 12,436	7460* 16,449*	3780 8335	5410 11,929	2750 6064	—	—	3570* 7872*	2240 4939

**323D L ● Mass Boom ● 600 mm (24") Track Shoes**

Stick		3 m 9'10"		4.5 m 15'0"		6 m 20'0"		7.5 m 25'0"		9 m 30'0"		At Max. Reach	
		Front	Side	Front	Side	Front	Side	Front	Side	Front	Side	Front	Side
2.4 m 7'10"	kg lb	*9350 *20,617	*9350 *20,617	*10 450 *23,042	6650 14,663	7250 15,986	4400 9702	5150 11,356	3150 6946	—	—	5100 16,346	3100 13,036

\*Load limited by hydraulic capacity rather than tipping.

**France Sourced**

**323D L ● Reach Boom ● 600 mm (24") Track Shoes**

Stick		3 m 9'10"		4.5 m 15'0"		6 m 20'0"		7.5 m 25'0"		9 m 30'0"		At Max. Reach	
		Front	Side	Front	Side	Front	Side	Front	Side	Front	Side	Front	Side
1.9 m 6'3"	kg lb	—	—	10 440* 23,020*	5340 11,775	7370 16,251	3580 7894	5280 11,642	2620 5777	—	—	5170 11,400	2570 5667
2.5 m 8'2"	kg lb	6050* 13,340*	6050* 13,340*	10 530* 23,219*	5600 12,348	7570 16,692	3770 8313	5410 11,929	2750 6064	—	—	4320* 9526*	2420 5336
2.9 m 9'6"	kg lb	6820* 15,038*	6820* 15,038*	10 330* 22,778*	5640 12,436	7460* 16,449*	3780 8335	5410 11,929	2750 6064	—	—	3570* 7872*	2240 4939

**323D LN ● Reach Boom ● 500 mm (20") Track Shoes**

Stick		3 m 9'10"		4.5 m 15'0"		6 m 20'0"		7.5 m 25'0"		9 m 30'0"		At Max. Reach	
		Front	Side	Front	Side	Front	Side	Front	Side	Front	Side	Front	Side
1.9 m 6'3"	kg lb	—	—	10 440* 23,020	5490 12,105	7470 16,471	3680 8114	5360 11,819	2700 5954	—	—	5250 11,576	2640 5821
2.5 m 8'2"	kg lb	6050* 13,340	6050* 13,340	10 530* 23,219	5750 12,679	7620* 16,802	3870 8533	5490 12,105	2830 6240	—	—	4320* 9526	2500 5513
2.92 m 9'6"	kg lb	6820* 15,038	6820* 15,038	10 330* 22,778	5790 12,767	7460* 16,449	3890 8577	5490 12,105	2830 6240	—	—	3570* 7872	2310 5094

**China Sourced**

**323D L ● Reach Boom ● 600 mm (24") Track Shoes**

Stick		3 m 9'10"		4.5 m 15'0"		6 m 20'0"		7.5 m 25'0"		9 m 30'0"		At Max. Reach	
		Front	Side	Front	Side	Front	Side	Front	Side	Front	Side	Front	Side
2.5 m 8'2"	kg lb	—	—	9750 21,495	6100 13,448	6750 14,881	3850 8488	4650 10,251	2650 5842	—	—	3600 7937	2250 4960
2.9 m 9'6"	kg lb	—	—	9950 21,936	6100 13,448	6750 14,881	3850 8488	4700 10,362	2650 5842	—	—	2950 6504	2050 4519

**323D L ● Mass Boom ● 800 mm (32") Track Shoes**

Stick		3 m 9'10"		4.5 m 15'0"		6 m 20'0"		7.5 m 25'0"		9 m 30'0"		At Max. Reach	
		Front	Side	Front	Side	Front	Side	Front	Side	Front	Side	Front	Side
2.4 m 7'9"	kg lb	—	—	10 000 22,046	6300 13,889	6900 15,212	3900 8598	4700 10,362	2650 5842	—	—	4450 9811	2500 5512

\*Load limited by hydraulic capacity rather than tipping.



# Excavators

## Lifting Capacity At Ground Level

- 323D L ● 323D LN ● 323D SA

### France Sourced

#### 323D L ● VA Boom ● 500 mm (20") Track Shoes

Stick		3 m 9'10"		4.5 m 15'0"		6 m 20'0"		7.5 m 25'0"		9 m 30'0"		At Max. Reach	
		Front	Side	Front	Side	Front	Side	Front	Side	Front	Side	Front	Side
1.9 m	kg	14 600*	10 410	10 110*	5750	7360*	3750	5180	2450	—	—	4570*	2200
6'3"	lb	32,193*	22,954	22,293*	12,679	16,229*	8269	11,422	5402	—	—	10,077*	4851
2.5 m	kg	15 190*	10 960	10 290*	6070	7500	4010	5420	2690	—	—	4140*	2100
8'2"	lb	33,494*	24,167	22,689*	13,384	16,538	8842	11,951	5931	—	—	9129*	4631
2.92 m	kg	15 180*	11 220	10 280*	6180	7490	4070	5480	2760	—	—	3430*	1940
9'6"	lb	33,472*	24,740	22,667*	13,627	16,515	8974	12,083	6086	—	—	7563*	4278

#### 323D LN ● VA Boom ● 500 mm (20") Track Shoes

Stick		3 m 9'10"		4.5 m 15'0"		6 m 20'0"		7.5 m 25'0"		9 m 30'0"		At Max. Reach	
		Front	Side	Front	Side	Front	Side	Front	Side	Front	Side	Front	Side
1.9 m	kg	14 600*	10 680	10 110*	5900	7360*	3850	5260	2530	—	—	4570*	2280
6'3"	lb	32,193*	23,549	22,293*	13,010	16,229*	8489	11,598	5579	—	—	10,077*	5027
2.5 m	kg	15 190*	11 220	10 290*	6220	7520*	4120	5500	2770	—	—	4140*	2170
8'2"	lb	33,494*	24,740	22,689*	13,715	16,582*	9085	12,128	6108	—	—	9129*	4785
2.92 m	kg	15 180*	11 480	10 280*	6330	7500*	4170	5560	2840	—	—	3430*	2000
9'6"	lb	33,472*	25,313	22,667*	13,958	16,538*	9195	12,260	6262	—	—	7563*	4410

#### 323D SA ● Reach Boom ● 500 mm (22") Track Shoes

Stick		3 m 9'10"		4.5 m 15'0"		6 m 20'0"		7.5 m 25'0"		9 m 30'0"		At Max. Reach	
		Front	Side	Front	Side	Front	Side	Front	Side	Front	Side	Front	Side
1.9 m	kg	—	—	10 450*	5440	7260	3660	5230	2680	—	—	5140	2640
6'3"	lb	—	—	23,042*	11,995	16,008	8070	11,532	5909	—	—	11,334	5821
2.5 m	kg	6260*	6260*	10 550*	5690	7450	3840	5360	2820	—	—	4350*	2490
8'2"	lb	13,803*	13,803*	23,263*	12,546	16,427	8467	11,819	6218	—	—	9592*	5490
2.9 m	kg	11 650*	11 650*	7440*	6570	5880*	4300	5130*	3040	—	—	3040*	2370
9'6"	lb	25,688*	25,688*	16,405*	14,487	12,965*	9482	11,312*	6703	—	—	6703*	5226

#### 323D SA ● VA Boom ● 500 mm (22") Track Shoes

Stick		3 m 9'10"		4.5 m 15'0"		6 m 20'0"		7.5 m 25'0"		9 m 30'0"		At Max. Reach	
		Front	Side	Front	Side	Front	Side	Front	Side	Front	Side	Front	Side
1.9 m	kg	14 610*	10 460	10 110*	5820	7340*	3820	5120	2510	—	—	4550*	2270
6'3"	lb	32,215*	23,064	22,293*	12,833	16,185*	8423	11,290	5535	—	—	10,033*	5005
2.5 m	kg	15 150*	10 990	10 300*	6140	7460	4080	5350	2750	—	—	4160*	2160
8'2"	lb	33,406*	24,233	22,712*	13,539	16,449	8996	11,797	6064	—	—	9173*	4763
2.92 m	kg	15 270*	11 230	10 280*	6250	7420*	4130	5410	2800	—	—	3450*	2000
9'6"	lb	33,670*	24,762	22,667*	13,781	16,361*	9107	11,929	6174	—	—	7607*	4410

\*Load limited by hydraulic capacity rather than tipping.

Japan/U.S. Sourced

**324D • Reach Boom • 600 mm (24") Track Shoes**

Stick	Bucket	kg lb	3 m 9'10"		4.5 m 15'0"		6 m 20'0"		7.5 m 25'0"		9 m 30'0"		At Max. Reach	
			Front	Side	Front	Side	Front	Side	Front	Side	Front	Side	Front	Side
2500 mm 8'2"	S1355X 4'5"	kg lb	—	—	10 650 22,800	6550 14,100	6650 14,300	4250 9150	4700 10,050	3000 6400	—	—	3500 7700	2200 4850
2950 mm 9'8"	S1225X 4'1"	kg lb	5150*	5150*	10 750 23,050	6650 14,300	6700 14,400	4300 9250	4700 10,100	3050 6450	—	—	3250 7150	2050 4500
3600 mm 11'10"	B1220X 4'0"	kg lb	6000*	6000*	10 900 23,300	6750 14,550	6800 14,600	4400 9400	4800 10,250	3100 6600	3550 7600	2250 4850	3000 6650	1900 4200

**324D • Mass Boom • 600 mm (24") Track Shoes**

Stick	Bucket	kg lb	3 m 9'10"		4.5 m 15'0"		6 m 20'0"		7.5 m 25'0"		9 m 30'0"		At Max. Reach	
			Front	Side	Front	Side	Front	Side	Front	Side	Front	Side	Front	Side
2500 mm 8'2"	D1345X 4'5"	kg lb	—	—	10 500 22,500	6400 13,700	6450 13,800	4000 8550	4400 9400	2700 5750	—	—	3600 7950	2200 4800

**324D L • Reach Boom • 800 mm (32") Track Shoes**

Stick	Bucket	kg lb	3 m 9'10"		4.5 m 15'0"		6 m 20'0"		7.5 m 25'0"		9 m 30'0"		At Max. Reach	
			Front	Side	Front	Side	Front	Side	Front	Side	Front	Side	Front	Side
2500 mm 8'2"	HD 36"	kg lb	—	—	13 930* 30,150*	8270 17,800	8710 18,700	5340 11,500	6080 13,050	3770 8100	—	—	5030 11,100	3100 6850
2950 mm 9'8"	HD 36"	kg lb	4830*	4830*	13 710* 29,650*	8330 17,900	8730 18,750	5350 11,500	6070 13,050	3750 8050	—	—	4620 10,200	2830 6250
3600 mm 11'10"	HDP 42"	kg lb	6530*	6530*	13 130* 28,400*	8370 18,000	8760 18,800	5380 11,550	6100 13,100	3780 8100	4530 9700	2770 5950	3960* 8700*	2560 5650

**324D L • Mass Boom • 800 mm (32") Track Shoes**

Stick	Bucket	kg lb	3 m 9'10"		4.5 m 15'0"		6 m 20'0"		7.5 m 25'0"		9 m 30'0"		At Max. Reach	
			Front	Side	Front	Side	Front	Side	Front	Side	Front	Side	Front	Side
2500 mm 8'2"	HD 48"	kg lb	—	—	13 420* 29,050*	7850 16,850	8320 17,850	4940 10,600	5680 12,200	3360 7200	—	—	4600 10,150	2670 5900

\*Load limited by hydraulic capacity rather than tipping.

**Belgium Sourced**

**324D L ● Reach Boom ● 800 mm (32") Track Shoes**

Stick		3 m 9'10"		4.5 m 15'0"		6 m 20'0"		7.5 m 25'0"		9 m 30'0"		At Max. Reach	
		Front	Side	Front	Side	Front	Side	Front	Side	Front	Side	Front	Side
2500 mm 8'2"	kg lb	—	—	14 210* 31,350*	8710 19,200	9130 20,150	5740 12,700	6510 14,350	4180 9200	—	—	5560 12,300	3590 7900
2950 mm 9'8"	kg lb	6100* 13,450*	6100* 13,450*	13 970* 30,800*	8750 19,300	9150 20,200	5750 12,700	6490 14,300	4160 9200	—	—	5140 11,300	3300 7300

**324D L ● Mass Boom ● 800 mm (32") Track Shoes**

Stick		3 m 9'10"		4.5 m 15'0"		6 m 20'0"		7.5 m 25'0"		9 m 30'0"		At Max. Reach	
		Front	Side	Front	Side	Front	Side	Front	Side	Front	Side	Front	Side
2000 mm 6'7"	kg lb	—	—	14 150* 31,200*	8660 19,100	9100 20,050	5680 12,500	—	—	—	—	6750 14,900	4290 9450
2500 mm 8'2"	kg lb	9490* 20,900*	9490* 20,900*	13 930* 30,700*	8680 19,150	9080 20,000	5660 12,500	6420 14,150	4070 8950	—	—	6090 13,400	3860 8500

**324D L ● VA Boom ● 800 mm (32") Track Shoes**

Stick		3 m 9'10"		4.5 m 15'0"		6 m 20'0"		7.5 m 25'0"		9 m 30'0"		At Max. Reach	
		Front	Side	Front	Side	Front	Side	Front	Side	Front	Side	Front	Side
2500 mm 8'2"	kg lb	15 540* 34,250*	15 540* 34,250*	14 190* 31,300*	9620 21,200	9660 21,300	6270 13,850	6720 14,800	4310 9500	—	—	5360 11,800	3410 7500
2950 mm 9'8"	kg lb	17 330* 38,200*	17 330* 38,200*	14 140* 31,200*	9740 21,500	9640* 21,250*	6310 13,900	6770 14,900	4350 9600	4960 10,940	3140 6900	4950 10,900	3140 6900

**324D LN ● Reach Boom ● 600 mm (24") Track Shoes**

Stick		3 m 9'10"		4.5 m 15'0"		6 m 20'0"		7.5 m 25'0"		9 m 30'0"		At Max. Reach	
		Front	Side	Front	Side	Front	Side	Front	Side	Front	Side	Front	Side
2500 mm 8'2"	kg lb	—	—	14 210* 31,350*	7650 16,850	8890 19,600	5080 11,200	6330 13,950	3700 8150	—	—	5410 11,950	3170 7000
2950 mm 9'8"	kg lb	6100* 13,450*	6100* 13,450*	13 970* 30,800*	7690 19,950	8900 19,600	5090 11,200	6320 13,950	3680 8100	—	—	4990 11,000	2920 6450

**324D LN ● Mass Boom ● 600 mm (24") Track Shoes**

Stick		3 m 9'10"		4.5 m 15'0"		6 m 20'0"		7.5 m 25'0"		9 m 30'0"		At Max. Reach	
		Front	Side	Front	Side	Front	Side	Front	Side	Front	Side	Front	Side
2000 mm 6'7"	kg lb	—	—	14 150* 31,200*	7600 16,750	8860 19,550	5010 11,050	—	—	—	—	6560 14,450	3790 8350
2500 mm 8'2"	kg lb	9490* 20,950*	9490* 20,950*	13 930* 30,700*	7610 16,750	8840 19,500	4990 11,000	6250 13,750	3590 7900	—	—	5920 13,050	3410 7500

**324D LN ● VA Boom ● 600 mm (24") Track Shoes**

Stick		3 m 9'10"		4.5 m 15'0"		6 m 20'0"		7.5 m 25'0"		9 m 30'0"		At Max. Reach	
		Front	Side	Front	Side	Front	Side	Front	Side	Front	Side	Front	Side
2500 mm 8'2"	kg lb	15 540* 34,250*	15 540* 34,250*	14 190* 31,300*	8510 18,750	9410 20,750	5580 12,300	6540 14,400	3820 8400	—	—	5210 11,500	3010 6650
2950 mm 9'8"	kg lb	17 330* 38,200*	16 400 36,150	14 140* 31,300*	8630 19,000	9410 20,750	5620 13,400	6590 14,550	3860 8500	—	—	4810 10,600	2760 6100

\*Load limited by hydraulic capacity rather than tipping.

All weights are without bucket, with quick coupler, heavy lift on.

Japan/U.S. Sourced

**328D LCR ● Reach Boom ● 850 mm (34") Track Shoes**

Stick	Bucket	3 m 9'10"		4.5 m 15'0"		6 m 20'0"		7.5 m 25'0"		9 m 30'0"		At Max. Reach		
		Front	Side	Front	Side	Front	Side	Front	Side	Front	Side	Front	Side	
2650 mm 8'8"	1.2 m <sup>3</sup> 1.57 yd <sup>3</sup>	kg lb	—	—	15 550* 33,700*	10 150 21,800	11 300* 24,450*	6600 14,200	8450 18,100	4750 10,150	—	—	4500* 9950*	3300 7250
3200 mm 10'6"	1.2 m <sup>3</sup> 1.57 yd <sup>3</sup>	kg lb	5900* 13,450*	5900* 13,450*	15 450* 33,400*	10 100 21,750	11 100* 24,000*	6550 14,050	8400 18,000	4650 10,000	6300* 13,100*	3500 7710	3600* 7900*	2950 6500

**329D ● Reach Boom ● 600 mm (24") Track Shoes**

Stick	Bucket	3 m 9'10"		4.5 m 15'0"		6 m 20'0"		7.5 m 25'0"		9 m 30'0"		At Max. Reach		
		Front	Side	Front	Side	Front	Side	Front	Side	Front	Side	Front	Side	
2000 mm 6'7"	D1430X 4'8"	kg lb	—	—	12 500 26,800	7700 16,500	7800 16,800	5000 10,700	5500 11,800	3550 7550	—	—	4200 9250	2650 5850
2650 mm 8'8"	C1470X 4'10"	kg lb	—	—	13 000 27,850	8150 17,500	8150 17,500	5300 11,400	5750 12,350	3800 8100	—	—	4000 8850	2600 5750
3000 mm 9'10"	C1370X 4'6"	kg lb	—	—	13 050 27,900	8150 17,550	8150 17,550	5350 11,450	5750 12,350	3800 8100	4300 9450	2800 6150	3700 8200	2450 5400
3200 mm 10'6"	C1370X 4'6"	kg lb	4600 10,650	4600 10,650	13 050 27,950	8200 17,600	8150 17,550	5350 11,450	5750 12,350	3800 8100	4300 9200	2800 5950	3450 7600	2350 5150

**329D ● Mass Boom ● 600 mm (24") Track Shoes**

Stick	Bucket	3 m 9'10"		4.5 m 15'0"		6 m 20'0"		7.5 m 25'0"		9 m 30'0"		At Max. Reach		
		Front	Side	Front	Side	Front	Side	Front	Side	Front	Side	Front	Side	
2500 mm 8'2"	D1500X 4'11"	kg lb	—	—	13 000 27,850	8100 17,350	8050 17,250	5200 11,100	5600 12,000	3600 7700	—	—	4400 9650	2800 6150

**329D L ● Reach Boom ● 800 mm (32") Track Shoes**

Stick	Bucket	3 m 9'10"		4.5 m 15'0"		6 m 20'0"		7.5 m 25'0"		9 m 30'0"		At Max. Reach		
		Front	Side	Front	Side	Front	Side	Front	Side	Front	Side	Front	Side	
2000 mm 6'7"	D1520MX 5'0"	kg lb	—	—	14 900 32,800	9100 19,550	9400 20,200	5850 12,600	6600 14,100	4150 8850	—	—	5050 11,050	3150 6900
2650 mm 8'8"	HD 36"	kg lb	—	—	16 000* 35,600*	9650 20,750	10 620 22,800	6280 13,500	7450 16,000	4480 9650	—	—	5720 12,600	3440 7600
3200 mm 10'6"	HD 36"	kg lb	4870* 11,250*	4870* 11,250*	16 150* 34,950*	9650 20,750	10 590 22,750	6230 13,400	7380 15,850	4410 9500	5500 11,800	3270 7000	4870* 10,750*	3120 6900
3750 mm 12'4"	HDP 36"	kg lb	6190* 14,200*	6190* 14,200*	15 450* 33,400*	9660 20,800	10 590 22,750	6220 13,400	7350 15,800	4380 9400	5460 11,750	3220 6900	3920* 8650*	2740 6050

**329D L ● Mass Boom ● 800 mm (32") Track Shoes**

Stick	Bucket	3 m 9'10"		4.5 m 15'0"		6 m 20'0"		7.5 m 25'0"		9 m 30'0"		At Max. Reach		
		Front	Side	Front	Side	Front	Side	Front	Side	Front	Side	Front	Side	
2500 mm 8'2"	HD 48"	kg lb	8240* 19,000*	8240* 19,000*	16 040* 34,700*	9450 20,300	10 410 22,350	6010 12,900	7160 15,350	4160 8950	—	—	6210 13,700	3610 7950
3200 mm 10'6"	HD 36"	kg lb	9430* 21,600*	9430* 21,600*	16 070* 34,750*	9950 21,400	10 790 23,200	6400 13,750	7500 16,100	4510 9700	—	—	4680* 10,300*	3530 7800

\*Load limited by hydraulic capacity rather than tipping.

**Belgium Sourced**

**329D L ● Reach Boom ● 800 mm (32") Track Shoes**

Stick		3 m 9'10"		4.5 m 15'0"		6 m 20'0"		7.5 m 25'0"		9 m 30'0"		At Max. Reach	
		Front	Side	Front	Side	Front	Side	Front	Side	Front	Side	Front	Side
2000 mm 6'7"	kg lb	—	—	16 530* 36,450*	9730 21,450*	10 720 23,650	6370 14,050	7600 16,750	4620 10,200	—	—	6680 14,700	4090 9000
2650 mm 8'8"	kg lb	—	—	16 870* 37,200*	10 190 22,450	11 100 24,450	6730 14,850	7890 17,400	4920 10,850	—	—	6160 13,600	8550 18,850
3200 mm 10'6"	kg lb	5850* 12,900*	5850* 12,900*	16 490* 36,360*	10 160 22,400	11 060 24,500	6690 14,750	7840 17,250	4860 10,700	5960 13,150	3720 8200	4990* 11,000*	3510 7750

**329D L ● Mass Boom ● 800 mm (32") Track Shoes**

Stick		3 m 9'10"		4.5 m 15'0"		6 m 20'0"		7.5 m 25'0"		9 m 30'0"		At Max. Reach	
		Front	Side	Front	Side	Front	Side	Front	Side	Front	Side	Front	Side
2500 mm 8'2"	kg lb	8880* 19,550*	8880* 19,550*	16 650* 39,700	10 080 22,250	10 970 24,200	6560 14,450	7720 17,050	4720 10,400	—	—	6990 15,400	4290 9450

**329D L ● VA Boom ● 800 mm (32") Track Shoes**

Stick		3 m 9'10"		4.5 m 15'0"		6 m 20'0"		7.5 m 25'0"		9 m 30'0"		At Max. Reach	
		Front	Side	Front	Side	Front	Side	Front	Side	Front	Side	Front	Side
2000 mm 6'7"	kg lb	18 350* 19,580*	18 350* 19,580*	16 270* 35,900*	10 300 22,700	11 200 24,700	6710 14,800	7660 16,750	4590 10,100	—	—	6380 14,100	3790 8350
2650 mm 8'8"	kg lb	15 240* 33,600*	15 240* 33,600*	16 630* 36,650*	10 860 23,946	11 500 25,350	7110 15,700	8100 17,850	5010 11,050	5940 13,100	3640 8050	5900 13,000	3620 7800

**329D LN ● Reach Boom ● 600 mm (24") Track Shoes**

Stick		3 m 9'10"		4.5 m 15'0"		6 m 20'0"		7.5 m 25'0"		9 m 30'0"		At Max. Reach	
		Front	Side	Front	Side	Front	Side	Front	Side	Front	Side	Front	Side
2000 mm 6'7"	kg lb	—	—	16 530* 36,450*	8450 18,650	10 340 22,800	5560 12,250	7320 16,150	4040 8900	—	—	6440 14,200	3570 7850
2650 mm 8'8"	kg lb	—	—	16 870* 37,200	8900 19,600	10 720 23,650	5930 13,100	7610 16,750	4340 9550	—	—	5940 13,100	3410 7500
3200 mm 10'6"	kg lb	5850* 12,900*	5850* 12,900*	16 490* 36,350	8870 19,550	10 680 23,550	5880 12,950	7560 16,650	4280 9450	5740 12,650	3270 7200	4990* 11,000*	3080 6800

**329D LN ● Mass Boom ● 600 mm (24") Track Shoes**

Stick		3 m 9'10"		4.5 m 15'0"		6 m 20'0"		7.5 m 25'0"		9 m 30'0"		At Max. Reach	
		Front	Side	Front	Side	Front	Side	Front	Side	Front	Side	Front	Side
2500 mm 8'2"	kg lb	8880* 19,600*	8880* 19,600*	16 650* 36,700*	8780 19,350	10 580 23,350	5750 12,650	7440 16,400	4130 9100	—	—	6740 14,850	3750 8250

**329D LN ● VA Boom ● 800 mm (32") Track Shoes**

Stick		3 m 9'10"		4.5 m 15'0"		6 m 20'0"		7.5 m 25'0"		9 m 30'0"		At Max. Reach	
		Front	Side	Front	Side	Front	Side	Front	Side	Front	Side	Front	Side
2500 mm 8'2"	kg lb	15 240* 33,600*	15 240* 33,600*	16 630* 36,700*	10 860 23,950	11 500 25,350	7110 15,650	8100 17,850	5010 11,050	5940 13,100	3640 7800	5900 13,000	3620 8000

\*Load limited by hydraulic capacity rather than tipping.

All weights are without bucket, with quick coupler, heavy lift on.

Japan/U.S./Brazil Sourced

**336D • Reach Boom • 600 mm (24") Track Shoes**

Stick	Bucket		3 m 9'10"		4.5 m 15'0"		6 m 20'0"		7.5 m 25'0"		9 m 30'0"		At Max. Reach	
			Front	Side	Front	Side	Front	Side	Front	Side	Front	Side	Front	Side
2150 mm 7'1"	E1470X 4'10"	kg lb	—	—	16 250 34,800	10 450 22,450	10 100 21,700	6750 14,500	7100 15,250	4750 10,200	—	—	5000 11,000	3300 7300
2800 mm 9'2"	D1500X 4'11"	kg lb	—	—	16 850 36,150	11 050 23,700	10 500 22,550	7150 15,300	7400 15,850	5050 10,850	5500 11,800	3750 8000	4700 10,300	3150 6950
3200 mm 10'6"	D1430X 4'8"	kg lb	—	—	16 850 36,100	11 000 23,650	10 500 22,550	7100 15,300	7400 15,850	5050 10,800	5500 11,800	3750 8000	4450 9750	3000 6650
3900 mm 12'10"	D1345X 4'5"	kg lb	6750 15,400	6750 15,400	16 900 36,550	11 200 24,050	10 600 22,750	7200 15,500	7400 15,900	5100 10,900	5500 11,800	3750 7950	3600 7850	2600 5700

**336D • Mass Boom • 600 mm (24") Track Shoes**

Stick	Bucket		3 m 9'10"		4.5 m 15'0"		6 m 20'0"		7.5 m 25'0"		9 m 30'0"		At Max. Reach	
			Front	Side	Front	Side	Front	Side	Front	Side	Front	Side	Front	Side
2550 mm 8'4"	E1470X 4'10"	kg lb	—	—	16 750 35,900	10 900 23,450	10 350 22,250	7000 15,000	7250 15,500	4900 10,500	—	—	4950 10,900	3300 7250

**336D L • Reach Boom • 800 mm (32") Track Shoes**

Stick	Bucket		3 m 9'10"		4.5 m 15'0"		6 m 20'0"		7.5 m 25'0"		9 m 30'0"		At Max. Reach	
			Front	Side	Front	Side	Front	Side	Front	Side	Front	Side	Front	Side
3200 mm 10'6"	GP 36"	kg lb	7130 16,350	7130 16,350	18 080 39,150	11 760 25,300	12 920 27,950	7660 16,500	9330 20,050	5470 11,800	6990 15,000	4090 8750	4860 10,700	3210 7100
3900 mm 12'10"	GP 36"	kg lb	7700 17,550	7700 17,550	17 490 37,800	11 890 25,600	12 400 26,850	7710 16,600	9330 20,050	5460 11,750	6960 14,950	4040 8650	3720 8200	2780 6150

**336D L • Mass Boom • 800 mm (32") Track Shoes**

Stick	Bucket		3 m 9'10"		4.5 m 15'0"		6 m 20'0"		7.5 m 25'0"		9 m 30'0"		At Max. Reach	
			Front	Side	Front	Side	Front	Side	Front	Side	Front	Side	Front	Side
2150 mm 7'1"	E1470X 4'10"	kg lb	—	—	16 800 36,450	10 950 23,500	12 300 26,600	7050 15,200	8800 18,900	5000 10,750	—	—	6200 13,650	3500 7700
2550 mm 8'4"	HD 36"	kg lb	—	—	17 550* 38,000*	11 090 23,850	12 570* 27,200*	7110 15,300	8840 19,000	4980 10,700	—	—	6850 15,100	3810 8400

\*Load limited by hydraulic capacity rather than tipping.

**Belgium Sourced**

**336D L ● Reach Boom ● 700 mm (28") Track Shoes**

Stick		3 m 9'10"		4.5 m 15'0"		6 m 20'0"		7.5 m 25'0"		9 m 30'0"		At Max. Reach	
		Front	Side	Front	Side	Front	Side	Front	Side	Front	Side	Front	Side
2150 mm 7'1"	kg lb	—	—	18 310* 40,350*	11 700 25,800	13 220 29,150	7680 16,950	9390 20,700	5600 12,350	—	—	7670 16,900	4610 10,150
2800 mm 9'2"	kg lb	—	—	18 780* 41,400*	12 170 26,850	13 570* 29,900	8010 17,650	9620 21,200	5830 12,650	7320 16,150	4460 9850	6890 15,200	4260 9400
3200 mm 10'5"	kg lb	7490* 16,500*	7490* 16,500*	18 590* 39,600*	12 200 26,900	13 350* 29,450	8020 17,700	9610 21,200	5820 12,850	7290 16,100	4430 9750	6630 14,600	4020* 8850*
3900 mm 12'10"	kg lb	8120* 17,900*	8120* 17,900*	17 960* 39,600*	12 280 27,100	12 820* 28,250	8050 17,750	9610 21,200	5800 12,800	7250 16,000	4390 9700	5140* 11,350*	3520 7750

**336D L ● Mass Boom ● 700 mm (28") Track Shoes**

Stick		3 m 9'10"		4.5 m 15'0"		6 m 20'0"		7.5 m 25'0"		9 m 30'0"		At Max. Reach	
		Front	Side	Front	Side	Front	Side	Front	Side	Front	Side	Front	Side
2150 mm 7'1"	kg lb	—	—	18 560* 40,950*	11 970 26,400	13 430* 29,600*	7860 17,350	9530 21,000	5730 12,650	—	—	8210 18,100	4960 10,950
2550 mm 8'4"	kg lb	—	—	18 560* 40,950*	12 000 26,450	13 440 29,650	7860 17,350	9500 20,950	5690 12,550	—	—	7550 16,650	4550 10,000

**336D LN ● Reach Boom ● 600 mm (24") Track Shoes**

Stick		3 m 9'10"		4.5 m 15'0"		6 m 20'0"		7.5 m 25'0"		9 m 30'0"		At Max. Reach	
		Front	Side	Front	Side	Front	Side	Front	Side	Front	Side	Front	Side
2150 mm 7'1"	kg lb	—	—	18 310* 40,350*	10 390 22,900	13 050 28,800	6870 15,150	9260 20,400	5020 11,050	—	—	7570 16,700	4130 9100
2800 mm 9'2"	kg lb	—	—	18 780* 41,400*	10 850 23,900	13 400 29,550	7200 15,900	9490 20,900	5240 11,550	7220 15,900	4010 8850	6890 15,200	3830 8450
3200 mm 10'5"	kg lb	7490* 16,500*	7490* 16,500*	18 590* 41,000*	10 870 23,950	13 350* 29,450*	7210 15,900	9490 20,900	5230 11,550	7190 15,850	3980 8750	6540 14,400	3610 7950
3900 mm 12'10"	kg lb	8120* 17,900*	8120* 17,900*	17 960* 39,600*	10 950 24,150	12 820* 28,250*	7230 15,900	9480 20,900	5220 11,500	7150 15,750	3940 8700	5140* 11,350*	3150 6950

**336D LN ● Mass Boom ● 600 mm (24") Track Shoes**

Stick		3 m 9'10"		4.5 m 15'0"		6 m 20'0"		7.5 m 25'0"		9 m 30'0"		At Max. Reach	
		Front	Side	Front	Side	Front	Side	Front	Side	Front	Side	Front	Side
2150 mm 7'1"	kg lb	—	—	18 560* 40,950*	10 650 23,500	13 260 29,250	7050 15,550	9410 20,750	5140 11,350	—	—	8100 17,850	4460 9850
2550 mm 8'4"	kg lb	—	—	18 560* 40,950*	10 670 23,550	13 270 29,250	7050 15,550	9380 20,700	5110 11,250	—	—	7450 16,450	4080 9000

\*Load limited by hydraulic capacity rather than tipping.

All weights are without bucket, with quick coupler, heavy lift on.

Japan Sourced

345D ● Reach Boom ● 600 mm (24") Track Shoes

Bucket Type	Front Length		Heavy Lift		3 m 9'10"		4.5 m 15'0"		6 m 20'0"		7.5 m 25'0"		
	mm	ft			Front	Side	Front	Side	Front	Side	Front	Side	
TB1325XN	Stick	3900	12'10"	on	kg	8650*	8650*	23 000*	15 700	16 300*	10 100	11 350	7150
	Bucket	1325	4'4"		lb	19,600*	19,600*	49,750*	33,750	35,000	21,750	24,400	15,400
	Stick	3900	12'10"	off	kg	8350*	8350*	22 150*	15 700	15 650*	10 100	11 350	7150
	Bucket	1325	4'4"		lb	18,900*	18,900*	47,950*	33,750	33,850*	21,750	24,400	15,400
TB1525XN	Stick	3400	11'2"	on	kg	—	—	20 800*	15 550	16 150	10 000	11 300	7100
	Bucket	1525	5'0"		lb	16,100*	16,100*	48,300*	33,350	34,700	21,500	24,250	15,250
	Stick	3400	11'2"	off	kg	—	—	20 200*	15 550	15 950*	10 000	11 300	7100
	Bucket	1525	5'0"		lb	15,500*	15,500*	46,850*	33,350	34,450*	21,500	24,250	15,250
TB1628X	Stick	2900	9'6"	on	kg	—	—	19 800*	15 250	15 950	9800	11 200	7000
	Bucket	1628	5'4"		lb	—	—	46,050*	32,750	34,300	21,100	24,000	15,000
	Stick	2900	9'6"	off	kg	—	—	19 200*	15 250	15 950	9800	11 200	7000
	Bucket	1628	5'4"		lb	—	—	44,650*	32,750	34,300	21,100	24,000	15,000

Bucket Type	Front Length		Heavy Lift		9 m 30'0"		10.5 m 35'0"		At Max. Reach		
	mm	ft			Front	Side	Front	Side	Front	Side	
TB1325XN	Stick	3900	12'10"	on	kg	8450	5300	6550	4050	5400*	3450
	Bucket	1325	4'4"		lb	18,150	11,350	6550	4050	11,850*	7600
	Stick	3900	12'10"	off	kg	8450	5300	6550	4050	5200*	3450
	Bucket	1325	4'4"		lb	18,150	11,350	6550	4050	11,400*	7600
TB1525XN	Stick	3400	11'2"	on	kg	8400	5250	6550	4050	5400*	3700
	Bucket	1525	5'0"		lb	18,050	11,250	6550	4050	11,900*	8150
	Stick	3400	11'2"	off	kg	8400	5250	6550	4050	5200*	3700
	Bucket	1525	5'0"		lb	18,050	11,250	6550	4050	11,450*	8150
TB1628X	Stick	2900	9'6"	on	kg	8350	5200	6550	4050	6350*	4000
	Bucket	1628	5'4"		lb	17,950	11,150	6550	4050	14,000*	8750
	Stick	2900	9'6"	off	kg	8350	5200	6550	4050	6150*	4000
	Bucket	1628	5'4"		lb	17,950	11,150	6550	4050	13,500*	8750

\*Load limited by hydraulic capacity rather than tipping.



# Excavators

## Lifting Capacity At Ground Level

- 345D ● 345D L – FIX

### Japan Sourced

#### 345D ● Mass Boom ● 600 mm (24") Track Shoes

Bucket Type	Front Length		Heavy Lift		3 m 9'10"		4.5 m 15'0"		6 m 20'0"		7.5 m 25'0"		
	mm	ft			Front	Side	Front	Side	Front	Side	Front	Side	
UB1550X	Stick Bucket	3000	9'10"	on	kg	—	—	22 350*	14 900	15 700	9450	10 850	6600
	Bucket	1550	5'1"		lb	—	—	48,350*	31,950	33,700	20,350	23,250	14,150
UB1729X	Stick Bucket	3000	9'10"	off	kg	—	—	21 500*	14 900	15 300*	9450	10 850	6600
	Bucket	1550	5'1"		lb	—	—	46,500*	31,950	33,050*	20,350	23,250	14,150
UB1729X	Stick Bucket	2500	8'2"	on	kg	—	—	22 300*	14 900	15 750	9500	10 900	6700
	Bucket	1729	5'8"		lb	—	—	48,400*	31,950	33,750	20,450	23,400	14,300
UB1729X	Stick Bucket	2500	8'2"	off	kg	—	—	21 450*	14 900	15 550*	9500	10 900	6700
	Bucket	1729	5'8"		lb	—	—	46,550*	31,950	33,650*	20,450	23,400	14,300

Bucket Type	Front Length		Heavy Lift		9 m 30'0"		10.5 m 35'0"		At Max. Reach		
	mm	ft			Front	Side	Front	Side	Front	Side	
UB1550X	Stick Bucket	3000	9'10"	on	kg	7950	4750	6550	4050	5900*	3600
	Bucket	1550	5'1"		lb	17,000	10,150	—	—	12,950*	7950
UB1729X	Stick Bucket	3000	9'10"	off	kg	7950	4750	6550	4050	5650*	3600
	Bucket	1550	5'1"		lb	17,000	10,150	—	—	12,450*	7950
UB1729X	Stick Bucket	2500	8'2"	on	kg	8050	4850	6550	4050	6900	4100
	Bucket	1729	5'8"		lb	—	—	—	—	15,150	9050
UB1729X	Stick Bucket	2500	8'2"	off	kg	8050	4850	6550	4050	6900	4100
	Bucket	1729	5'8"		lb	—	—	—	—	15,150	9050

#### 345D L – FIX ● Long Reach Boom ● 900 mm (36") Track Shoes

Bucket Type	Front Length		Heavy Lift		3 m 9'10"		4.5 m 15'0"		6 m 20'0"		7.5 m 25'0"		
	mm	ft			Front	Side	Front	Side	Front	Side	Front	Side	
TB1325XN	Stick Bucket	4300	14'1"	on	kg	6650*	6650*	17 750*	15 950	15 800*	10 300	12 100*	7350
	Bucket	1325	4'4"		lb	15,050*	15,050*	41,000*	34,300	34,150*	22,200	26,100*	15,750
TB1325XN	Stick Bucket	4300	14'1"	off	kg	6400*	6400*	17 150*	15 950	15 200*	10 300	11 600*	7350
	Bucket	1325	4'4"		lb	14,500*	14,500*	39,750*	34,300	32,850*	22,200	25,050*	15,750
TB1325XN	Stick Bucket	3900	12'10"	on	kg	—	—	16 700*	15 800	16 050*	10 200	12 300*	7300
	Bucket	1325	4'4"		lb	—	—	38,600*	33,950	34,700*	21,950	26,550*	15,650
TB1325XN	Stick Bucket	3900	12'10"	off	kg	—	—	16 150*	15 800	15 450*	10 200	11 800*	7300
	Bucket	1325	4'4"		lb	—	—	37,400*	33,950	33,350*	21,950	25,500*	15,650

Bucket Type	Front Length		Heavy Lift		9 m 30'0"		10.5 m 35'0"		At Max. Reach		
	mm	ft			Front	Side	Front	Side	Front	Side	
TB1325XN	Stick Bucket	4300	14'1"	on	kg	9800*	5450	7600	4150	5100*	3100
	Bucket	1325	4'4"		lb	21,000	11,700	16,300	8850	11,250*	6800
TB1325XN	Stick Bucket	4300	14'1"	off	kg	9350*	5450	7600	4150	4900*	3100
	Bucket	1325	4'4"		lb	20,250*	11,700	16,300	8850	10,800*	6800
TB1325XN	Stick Bucket	3900	12'10"	on	kg	9750	5450	7600	4150	5750*	3300
	Bucket	1325	4'4"		lb	20,950	11,650	16,250	8850	12,700*	7250
TB1325XN	Stick Bucket	3900	12'10"	off	kg	9500*	5450	7600	4150	5550*	3300
	Bucket	1325	4'4"		lb	20,550*	11,650	16,250	8850	12,200*	7250

\*Load limited by hydraulic capacity rather than tipping.

Japan Sourced

345D L – FIX ● Reach Boom ● 900 mm (36") Track Shoes

Bucket Type	Front Length		Heavy Lift		3 m 9'10"		4.5 m 15'0"		6 m 20'0"		7.5 m 25'0"		
	mm	ft			Front	Side	Front	Side	Front	Side	Front	Side	
TB1325XN	Stick	3900	12'10"	on	kg	8650*	8650*	23 000*	16 550	16 300*	10 650	12 500*	7600
	Bucket	1325	4'4"		lb	19,600*	19,600*	49,750*	35,500	35,200*	22,950	27,050*	16,250
TB1628X	Stick	3900	12'10"	off	kg	8350*	8350*	22 150*	16 550	15 650*	10 650	12 050*	7600
	Bucket	1325	4'4"		lb	18,900*	18,900*	47,950*	35,500	33,850*	22,950	26,000*	16,250
TB1628X	Stick	3400	11'2"	on	kg	—	—	20 800*	16 350	16 600*	10 550	12 750*	7500
	Bucket	1628	5'4"		lb	16,100*	16,100*	48,350*	35,150	35,850*	22,700	27,550*	16,150
TB1758X	Stick	3400	11'2"	off	kg	—	—	20 200*	16 350	15 950*	10 550	12 250*	7500
	Bucket	1628	5'4"		lb	15,500*	15,500*	46,850*	35,150	34,500*	22,700	26,500*	16,150
TB1758X	Stick	2900	9'6"	on	kg	—	—	19 750*	16 000	16 550*	10 300	12 750*	7350
	Bucket	1758	5'9"		lb	—	—	45,900*	34,350	35,800*	22,200	27,550*	15,800
TB1758X	Stick	2900	9'6"	off	kg	—	—	19 150*	16 000	15 900*	10 300	12 250*	7350
	Bucket	1758	5'9"		lb	—	—	44,500*	34,350	34,400*	22,200	26,450*	15,800

Bucket Type	Front Length		Heavy Lift		9 m 30'0"		10.5 m 35'0"		At Max. Reach		
	mm	ft			Front	Side	Front	Side	Front	Side	
TB1325XN	Stick	3900	12'10"	on	kg	10 000	5650	7750	4300	5400*	3700
	Bucket	1325	4'4"		lb	21,400	12,100	—	—	11,850*	8150
TB1628X	Stick	3900	12'10"	off	kg	9750*	5650	7750	4300	5200*	3700
	Bucket	1325	4'4"		lb	21,100*	12,100	—	—	11,400*	8150
TB1628X	Stick	3400	11'2"	on	kg	9950	5600	—	—	5450*	4000
	Bucket	1628	5'4"		lb	21,350	12,000	—	—	11,950*	8750
TB1758X	Stick	3400	11'2"	off	kg	9900*	5600	—	—	5250*	4000
	Bucket	1628	5'4"		lb	21,350	12,000	—	—	11,500*	8750
TB1758X	Stick	2900	9'6"	on	kg	9850	5500	—	—	6300*	4200
	Bucket	1758	5'9"		lb	21,100	11,800	—	—	13,900*	9250
TB1758X	Stick	2900	9'6"	off	kg	9850	5500	—	—	6100*	4200
	Bucket	1758	5'9"		lb	21,100	11,800	—	—	13,400*	9250

345D L – FIX ● Mass Boom ● 900 mm (36") Track Shoes

Bucket Type	Front Length		Heavy Lift		3 m 9'10"		4.5 m 15'0"		6 m 20'0"		7.5 m 25'0"		
	mm	ft			Front	Side	Front	Side	Front	Side	Front	Side	
UB1600X	Stick	3000	9'10"	on	kg	—	—	19 150*	18 300	13 650*	11 550	10 850*	7900
	Bucket	1600	5'3"		lb	—	—	41,100*	39,450	29,400*	24,850	23,500*	16,950
UB1729X	Stick	3000	9'10"	off	kg	—	—	21 600*	15 800	15 400*	10 100	11 750*	7100
	Bucket	1600	5'3"		lb	—	—	46,750*	33,950	33,250*	21,700	25,400*	15,150
UB1729X	Stick	2500	8'2"	on	kg	—	—	22 300*	15 700	16 200*	10 050	12 400*	7100
	Bucket	1729	5'8"		lb	—	—	48,400*	33,700	35,000*	21,600	26,850*	15,200
UB1729X	Stick	2500	8'2"	off	kg	—	—	21 450*	15 700	15 550*	10 050	11 900*	7100
	Bucket	1729	5'8"		lb	—	—	46,550*	33,700	33,650*	21,600	25,750*	15,200

Bucket Type	Front Length		Heavy Lift		9 m 30'0"		10.5 m 35'0"		At Max. Reach		
	mm	ft			Front	Side	Front	Side	Front	Side	
UB1600X	Stick	3000	9'10"	on	kg	9200*	5600	—	—	4900*	3750
	Bucket	1600	5'3"		lb	20,000*	11,900	—	—	10,700*	8250
UB1729X	Stick	3000	9'10"	off	kg	9400*	5150	—	—	5750*	4000
	Bucket	1600	5'3"		lb	20,200*	11,000	—	—	12,700*	8750
UB1729X	Stick	2500	8'2"	on	kg	9600	5200	—	—	7650*	4400
	Bucket	1729	5'8"		lb	—	—	—	—	16,850*	9700
UB1729X	Stick	2500	8'2"	off	kg	9400*	5200	—	—	7650*	4400
	Bucket	1729	5'8"		lb	—	—	—	—	16,850*	9700

\*Load limited by hydraulic capacity rather than tipping.

**Japan Sourced**

**345D L – VG ● Long Reach Boom ● 900 mm (36") Track Shoes**

Bucket Type	Front Length		Heavy Lift		3 m 9'10"		4.5 m 15'0"		6 m 20'0"		7.5 m 25'0"		
	mm	ft			Front	Side	Front	Side	Front	Side	Front	Side	
TB1325XN	Stick	4300	14'1"	on	kg	7000*	7000*	17 750*	17 750*	15 900*	11 600	12 150*	8250
	Bucket	1325	4'4"		lb	15,850*	15,850*	41,050*	38,750	34,350*	24,950	26,250*	17,750
	Stick	4300	14'1"	off	kg	6750*	6750*	17 200*	17 200*	15 250*	11 600	11 650*	8250
	Bucket	1325	4'4"		lb	15,250*	15,250*	39,800*	38,750	33,000*	24,950	25,200*	17,750
TB1325XN	Stick	3900	12'10"	on	kg	—	—	16 900*	16 900*	16 100*	11 500	12 350*	8200
	Bucket	1325	4'4"		lb	14,600*	14,600*	39,000*	38,450	34,800*	24,750	26,650*	17,650
	Stick	3900	12'10"	off	kg	—	—	16 350*	16 350*	15 500*	11 500	11 850*	8200
	Bucket	1325	4'4"		lb	14,050*	14,050*	37,750*	37,750	33,450*	24,750	25,600*	17,650

Bucket Type	Front Length		Heavy Lift		9 m 30'0"		10.5 m 35'0"		At Max. Reach		
	mm	ft			Front	Side	Front	Side	Front	Side	
TB1325XN	Stick	4300	14'1"	on	kg	9800*	6200	7950	4750	5150*	3600
	Bucket	1325	4'4"		lb	21,200*	13,250	17,050	10,150	11,350*	7950
	Stick	4300	14'1"	off	kg	9400*	6200	7850*	4750	4950*	3600
	Bucket	1325	4'4"		lb	20,350*	13,250	16,950*	10,150	10,950*	7950
TB1325XN	Stick	3900	12'10"	on	kg	9950*	6150	7950	4750	5850*	3850
	Bucket	1325	4'4"		lb	21,500*	13,200	17,050	10,150	12,850*	8450
	Stick	3900	12'10"	off	kg	9550*	6150	7950*	4750	5600*	3850
	Bucket	1325	4'4"		lb	20,600*	13,200	17,050	10,150	12,350*	8450

**345D L – VG ● Reach Boom ● 750 mm (30") Track Shoes**

Bucket Type	Front Length		Heavy Lift		3 m 9'10"		4.5 m 15'0"		6 m 20'0"		7.5 m 25'0"		
	mm	ft			Front	Side	Front	Side	Front	Side	Front	Side	
TB1325XN	Stick	3900	12'10"	on	kg	8950*	8950*	22 950*	19 850	16 250*	12 750	12 450*	9100
	Bucket	1325	4'4"		lb	20,300*	20,300*	49,600*	42,700	35,100*	27,400	26,950*	19,500
	Stick	3900	12'10"	off	kg	8650*	8650*	22 100*	19 850	15 600*	12 750	11 950*	9100
	Bucket	1325	4'4"		lb	19,600*	19,600*	47,750*	42,700	33,750*	27,400	25,850*	19,500
TB1672EXN	Stick	3400	11'2"	on	kg	7300*	7300*	20 600*	19 400	16 150*	12 350	12 350*	8750
	Bucket	1672	5'6"		lb	16,650*	16,650*	47,750*	41,600	34,900*	26,550	26,650*	18,750
	Stick	3400	11'2"	off	kg	7050*	7050*	19 950*	19 400	15 550*	12 350	11 850*	8750
	Bucket	1672	5'6"		lb	16,000*	16,000*	46,250*	41,600	33,550*	26,550	25,550*	18,750
TB1758X	Stick	2900	9'6"	on	kg	—	—	19 850*	19 050	16 150*	12 150	12 350*	8650
	Bucket	1758	5'9"		lb	—	—	46,050*	40,900	34,900*	26,150	26,700*	18,550
	Stick	2900	9'6"	off	kg	—	—	19 200*	19 050	15 500*	12 150	11 850*	8650
	Bucket	1758	5'9"		lb	—	—	44,600*	40,900	33,500*	26,150	25,600*	18,550

Bucket Type	Front Length		Heavy Lift		9 m 30'0"		10.5 m 35'0"		At Max. Reach		
	mm	ft			Front	Side	Front	Side	Front	Side	
TB1325XN	Stick	3900	12'10"	on	kg	10 100*	6800	8050*	5250	5350*	4600
	Bucket	1325	4'4"		lb	21,800*	14,600	—	—	11,700*	10,050
	Stick	3900	12'10"	off	kg	9700*	6800	7800*	5250	5100*	4600
	Bucket	1325	4'4"		lb	20,900*	14,600	—	—	11,250*	10,050
TB1672EXN	Stick	3400	11'2"	on	kg	9900*	6500	—	—	5000*	4550
	Bucket	1672	5'6"		lb	21,300*	13,900	—	—	11,000*	10,000
	Stick	3400	11'2"	off	kg	9450*	6500	—	—	4800*	4550
	Bucket	1672	5'6"		lb	20,400*	13,900	—	—	10,550*	10,000
TB1758X	Stick	2900	9'6"	on	kg	9850*	6450	—	—	5950*	4900
	Bucket	1758	5'9"		lb	21,250*	13,800	—	—	13,100*	10,750
	Stick	2900	9'6"	off	kg	9450*	6450	—	—	5700*	4900
	Bucket	1758	5'9"		lb	20,350*	13,800	—	—	12,550*	10,750

\*Load limited by hydraulic capacity rather than tipping.

Japan Sourced

345D L – VG • Mass Boom • 750 mm (30") Track Shoes

Bucket Type	Front Length		Heavy Lift		3 m 9'10"		4.5 m 15'0"		6 m 20'0"		7.5 m 25'0"		
	mm	ft			Front	Side	Front	Side	Front	Side	Front	Side	
UB1729X	Stick	3000	9'10"	on	kg	7850*	7850*	21 850*	18 800	15 500*	11 850	11 750*	8250
	Bucket	1729	5'8"			lb	17,900*	17,900*	47,300*	40,350	33,550*	25,450	25,400*
	Stick	3000	9'10"	off	kg	7550*	7550*	21 000*	18 800	14 900*	11 850	11 250*	8250
	Bucket	1729	5'8"			lb	17,250*	17,250*	45,450*	40,350	32,150*	25,450	24,300*
UB1829X	Stick	2500	8'2"	on	kg	—	—	22 200*	19 150	16 150*	12 200	12 350*	8650
	Bucket	1829	6'0"			lb	—	—	48,100*	41,100	34,900*	26,300	26,700*
	Stick	2500	8'2"	off	kg	—	—	21 350*	19 150	15 500*	12 200	11 850*	8650
	Bucket	1829	6'0"			lb	—	—	46,250*	41,100	33,500*	26,300	25,600*

4

Bucket Type	Front Length		Heavy Lift		9 m 30'0"		10.5 m 35'0"		At Max. Reach		
	mm	ft			Front	Side	Front	Side	Front	Side	
UB1729X	Stick	3000	9'10"	on	kg	9250*	6000	—	—	5500*	4550
	Bucket	1729	5'8"			lb	19,900*	12,800	—	—	12,050*
	Stick	3000	9'10"	off	kg	8850*	6000	—	—	5250*	4550
	Bucket	1729	5'8"			lb	19,000*	12,800	—	—	11,550*
UB1829X	Stick	2500	8'2"	on	kg	9700*	6450	—	—	7700*	5550
	Bucket	1829	6'0"			lb	—	—	—	—	16,950*
	Stick	2500	8'2"	off	kg	9300*	6450	—	—	7450*	5550
	Bucket	1829	6'0"			lb	—	—	—	—	16,350*

Japan/U.S. Sourced

345D L – FIX • Reach Boom • 900 mm (36") Triple Grouser

Stick	Bucket		3 m 9'10"		4.5 m 15'0"		6 m 20'0"		7.5 m 25'0"	
			Front	Side	Front	Side	Front	Side	Front	Side
3350 mm 11'0"	1219 mm GP-C 4'0"	kg lb	—	—	21 560* 50,150*	17 490* 37,650*	17 550* 38,000*	11 340 24,400	13 520* 29,250*	8100 17,400
3900 mm 12'10"	1219 mm GP-C 4'0"	kg lb	—	—	24 410 52,800*	17 810 38,300*	17 290 37,400	11 530 24,850	13 320* 28,850	8220 17,700

Stick	Bucket		9 m 30'0"		10.5 m 35'0"		At Max. Reach	
			Front	Side	Front	Side	Front	Side
3350 mm 11'0"	1219 mm GP-C 4'0"	kg lb	10 550 22,650*	6050 13,000	—	—	8940 19,700*	5000 11,030
3900 mm 12'10"	1219 mm GP-C 4'0"	kg lb	10 630 22,850	6130 13,150	8250 16,650	4680 10,000	8070 17,800	4680 10,320

345D L – FIX • Mass Boom • 900 mm (36") Triple Grouser

Stick	Bucket		3 m 9'10"		4.5 m 15'0"		6 m 20'0"		7.5 m 25'0"	
			Front	Side	Front	Side	Front	Side	Front	Side
2500 mm 8'2"	1905 mm HDR V-edge 5'4"	kg lb	—	—	23 080 50,100*	16 370 35,150	16 710* 36,150*	10 350 22,250	12 680* 27,400*	7150 15,350
3000 mm 9'10"	1905 mm HDR V-edge 5'4"	kg lb	—	—	23 280* 50,400*	16 430 35,300	16 500* 35,650*	10 330 22,200	12 470* 26,950*	7080* 15,150*

Stick	Bucket		9 m 30'0"		10.5 m 35'0"		At Max. Reach	
			Front	Side	Front	Side	Front	Side
2500 mm 8'2"	1905 mm HDR V-edge 5'4"	kg lb	—	—	—	—	9920* 21,870*	5130 11,320
3000 mm 9'10"	1905 mm HDR V-edge 5'4"	kg lb	9510* 20,400*	5000 10,650	—	—	8920* 19,650*	4500 9920

\*Load limited by hydraulic capacity rather than tipping.

# Excavators

## Lifting Capacity At Ground Level

- 345D L – VG
- 345D L – W-VG

### U.S. Sourced

#### 345D L – VG ● Reach Boom ● 900 mm (36") Triple Grouser

Stick	Bucket		3 m 9'10"		4.5 m 15'0"		6 m 20'0"		7.5 m 25'0"	
			Front	Side	Front	Side	Front	Side	Front	Side
3350 mm 11'0"	1219 mm GP-C 4'8" GP-C	kg lb	7750*	7750*	21 830*	19 660	17 600*	12 660	13 560*	9050
			17,700*	17,700*	50,650*	42,250	38,100*	27,250	29,350*	19,450
3900 mm 12'10"	1219 mm GP-C 4'8" GP-C	kg lb	—	—	24 480*	19 960	17 380*	12 850	13 380*	9160
					52,950*	42,900	37,600*	27,650	28,950*	19,700

Stick	Bucket		9 m 30'0"		10.5 m 35'0"		At Max. Reach	
			Front	Side	Front	Side	Front	Side
3350 mm 11'0"	1219 mm GP-C 4'8" GP-C	kg lb	10 970*	6800	—	—	9110*	5710
			23,600	14,600			20,080*	12,590
3900 mm 12'10"	1219 mm GP-C 4'0" GP-C	kg lb	10 880*	6870	8610	5290	8190*	5350
			23,550*	14,750	16,150*	11,350	18,050*	11,790

#### 345D L – W-VG ● Reach Boom ● 900 mm (36") Track Shoes

Stick	Bucket		4.5 m 15'0"		6 m 20'0"		7.5 m 25'0"		9 m 30'0"	
			Front	Side	Front	Side	Front	Side	Front	Side
3900 mm 12'10"	1219 mm GP-C 4'8" GP-C	kg lb	24 480*	23 950	17 380*	15 140	13 380*	10 750	10 880*	8080
			52,950*	51,400	37,600*	32,600	28,950*	23,150	23,550*	17,350

Stick	Bucket		10.5 m 35'0"		At Max. Reach	
			Front	Side	Front	Side
3900 mm 12'10"	1219 mm GP-C 4'8" GP-C	kg lb	8760	6260	8190*	6350
			16,150*	13,450	18,050*	14,010

### Belgium Sourced

#### 345D L – VG ● Reach Boom ● 600 mm (24") Track Shoes ● Heavy Lift On

Stick	Bucket		4.5 m 15'0"		6 m 20'0"		7.5 m 25'0"		9 m 30'0"		At Max. Reach	
			Front	Side	Front	Side	Front	Side	Front	Side	Front	Side
2900 mm 9'6"	2.75 m <sup>3</sup> 3.6 yd <sup>3</sup>	kg lb	19 970	18 830	17 110	11 980	13 070	8430	10 330	6200	6060	4570
			44,035	41,520	37,730	26,420	28,820	18,590	22,780	13,670	13,360	10,075
3350 mm 11'0"	2.75 m <sup>3</sup> 3.6 yd <sup>3</sup>	kg lb	20 930	19 020	16 990	12 080	12 940	8470	10 330	6210	5120	4200
			46,150	41,940	37,460	26,635	28,535	18,675	22,780	13,695	11,290	9260

#### 345D L – VG ● Mass Boom ● 600 mm (24") Track Shoes ● Heavy Lift On

Stick	Bucket		4.5 m 15'0"		6 m 20'0"		7.5 m 25'0"		9 m 30'0"		At Max. Reach	
			Front	Side	Front	Side	Front	Side	Front	Side	Front	Side
2500 mm 9'2"	3.2 m <sup>3</sup> 4.2 yd <sup>3</sup>	kg lb	22 950	18 330	16 560	11 530	12 520	7950	9640	5660	7190	4610
			50,605	40,420	36,515	25,425	27,605	17,530	21,255	12,480	15,855	10,165
3000 mm 9'10"	3.2 m <sup>3</sup> 4.2 yd <sup>3</sup>	kg lb	23 130	18 420	16 350	11 520	12 320	7890	9620	5580	5420	4070
			51,000	40,615	36,050	25,400	27,165	17,400	21,210	12,305	11,950	8975

\*Load limited by hydraulic capacity rather than tipping.

**Belgium Sourced**

**365C L ● Heavy Lift ● 7.8 m (25'7") Reach Boom  
● 750 mm (30") Double Grousers**

Stick	Bucket	6 m 20'0"		7.5 m 25'0"		9 m 30'0"		10.5 m 35'0"		12 m 40'0"		At Max. Reach		
		Front	Side	Front	Side	Front	Side	Front	Side	Front	Side	Front	Side	
2840 mm 9'4"	3.2 m <sup>3</sup> 4.2 yd <sup>3</sup>	kg lb	24 360* 53,714	17 940 39,558	18 900* 41,675	12 620 27,827	15 070* 33,229	9360 20,639	11 610 25,600	7100 15,656	—	—	7820* 17,243	5920 13,054
3600 mm 11'10"	3.6 m <sup>3</sup> 4.71 yd <sup>3</sup>	kg lb	24 540* 54,111	18 070 39,844	18 760* 41,366	12 650 27,893	14 930* 32,921	9320 20,551	11 550 25,468	7030 15,501	—	—	7170* 15,810	5200 11,466
4150 mm 13'7"	2.6 m <sup>3</sup> 3.4 yd <sup>3</sup>	kg lb	24 710* 54,486	18 450 40,682	18 850* 41,564	12 960 28,577	15 070* 33,229	9600 21,168	11 820 26,063	7300 16,097	—	—	6290* 13,869	5030 11,091
4670 mm 15'4"	2.6 m <sup>3</sup> 3.4 yd <sup>3</sup>	kg lb	24 340* 53,670	18 570 40,947	18 480* 40,748	13 000 28,665	14 780* 32,590	9590 21,146	11 780 25,975	7250 15,986	9270 20,440	5550 12,238	5160* 11,378	4520 9967

**365C L ● Heavy Lift ● 6.6 m (21'8") Mass Boom  
● 750 mm (30") Double Grousers**

Stick	Bucket	4.5 m 15'0"		6 m 20'0"		7.5 m 25'0"		9 m 30'0"		At Max. Reach		
		Front	Side	Front	Side	Front	Side	Front	Side	Front	Side	
2570 mm 8'5"	4.4 m <sup>3</sup> 5.8 yd <sup>3</sup>	kg lb	29 800* 65,710	29 630 65,330	24 250* 53,470	18 180 40,090	18 400* 40,570	12 450 27,450	14 070* 31,020	8890 19,600	6620* 14,600	6620* 14,600
3000 mm 9'10"	4.0 m <sup>3</sup> 5.2 yd <sup>3</sup>	kg lb	30 540* 67,340	29 770 65,640	24 200* 53,360	18 220 40,180	18 320* 40,400	12 450 27,450	14 280* 31,490	8880* 19,580	5520* 12,170	5520* 12,170

**365C L ● Heavy Lift ● 7 m (23'0") Mass Boom  
● 750 mm (30") Double Grousers**

Stick	Bucket	4.5 m 15'0"		6 m 20'0"		7.5 m 25'0"		9 m 30'0"		At Max. Reach		
		Front	Side	Front	Side	Front	Side	Front	Side	Front	Side	
2570 mm 8'5"	4.0 m <sup>3</sup> 5.2 yd <sup>3</sup>	kg lb	21 240* 46,830	21 240* 46,830	23 810* 52,500	17 700 39,030	18 140* 40,000	12 190 26,880	14 120* 31,140	8760 19,320	6650* 14,670	6440 14,200
3000 mm 9'10"	3.8 m <sup>3</sup> 5.0 yd <sup>3</sup>	kg lb	22 400* 49,390	22 400* 49,390	23 810* 52,500	17 750 39,140	18 050* 39,800	12 190 26,880	14 160* 31,220	8740 19,270	5570* 12,280	5570* 12,280

\*Load limited by hydraulic capacity rather than tipping.

**Belgium Sourced**

**385C ● Heavy Lift ● 10 m (32'10") Reach Boom**  
● 650 mm (26") Track Shoes

Stick	Bucket	4.5 m 15'0"		6 m 20'0"		7.5 m 25'0"		9 m 30'0"		
		Front	Side	Front	Side	Front	Side	Front	Side	
4400 mm 14'5"	2.6 m <sup>3</sup> 3.4 yd <sup>3</sup>	kg lb	—	—	11 420* 25,180	11 420* 25,180	21 830 48,140	15 330 33,800	16 380 36,120	11 560 25,490
5500 mm 18'1"	2.0 m <sup>3</sup> 2.6 yd <sup>3</sup>	kg lb	—	—	14 770* 32,570	14 770* 32,570	22 290 49,150	15 760 34,750	16 710 36,850	11 870 26,170

Stick	Bucket	10.5 m 35'0"		12 m 40'0"		13.5 m 45'0"		At Max. Reach		
		Front	Side	Front	Side	Front	Side	Front	Side	
4400 mm 14'5"	2.6 m <sup>3</sup> 3.4 yd <sup>3</sup>	kg lb	12 770 28,160	8970 19,780	10 170 22,430	7030 15,500	8190 18,060	5530 12,190	6540 14,420	4280 9440
5500 mm 18'1"	2.0 m <sup>3</sup> 2.6 yd <sup>3</sup>	kg lb	10 350 22,820	9190 20,260	8330 18,370	7200 15,880	6740 14,860	5660 12,480	5790 12,770	3720 8200

**385C ● Heavy Lift ● 8.4 m (27'2") GP Boom**  
● 650 mm (26") Track Shoes

Stick	Bucket	4.5 m 15'0"		6 m 20'0"		7.5 m 25'0"		9 m 30'0"		
		Front	Side	Front	Side	Front	Side	Front	Side	
3400 mm 11'2"	3.8 m <sup>3</sup> 5 yd <sup>3</sup>	kg lb	—	—	29 120* 64,210	23 530 51,880	22 980 50,670	16 380 36,120	16 920 37,310	12 060 26,590
4400 mm 14'4"	3.5 m <sup>3</sup> 4.6 yd <sup>3</sup>	kg lb	13 430* 29,610	13 430* 29,610	34 300* 75,630	24 980 55,080	24 150 53,250	17 540 38,680	17 900 39,470	13 040 28,750
5500 mm 18'0"	3.5 m <sup>3</sup> 4.6 yd <sup>3</sup>	kg lb	15 780* 34,800	15 780* 34,800	33 500* 73,870	25 520 56,270	24 500 54,020	17 840 39,340	18 080 39,870	13 190 29,080

Stick	Bucket	10.5 m 35'0"		12 m 40'0"		13.5 m 45'0"		At Max. Reach		
		Front	Side	Front	Side	Front	Side	Front	Side	
3400 mm 11'2"	3.8 m <sup>3</sup> 5 yd <sup>3</sup>	kg lb	12 910 28,470	9090 20,040	—	—	—	—	7340* 16,190	5910 13,030
4400 mm 14'4"	3.5 m <sup>3</sup> 4.6 yd <sup>3</sup>	kg lb	13 800 30,430	9980 22,010	10 870 23,970	7730 18,050	—	—	6670* 14,710	6000 13,230
5500 mm 18'0"	3.5 m <sup>3</sup> 4.6 yd <sup>3</sup>	kg lb	13 870 30,580	10 040 22,140	10 880 23,990	7740 17,070	8140* 17,950	5980 13,190	4620* 10,190	4620* 10,190

**385C ● Heavy Lift ● 7.25 m (23'9") Mass Boom**  
● 650 mm (26") Track Shoes

Stick	Bucket	4.5 m 15'0"		6 m 20'0"		7.5 m 25'0"		9 m 30'0"		
		Front	Side	Front	Side	Front	Side	Front	Side	
2920 mm 9'5"	5.2 m <sup>3</sup> 6.8 yd <sup>3</sup>	kg lb	21 360* 47,100	21 360* 17,100	33 250* 73,320	24 610 54,270	23 620 52,080	16 920 37,310	17 160 37,840	12 240 26,990
3400 mm 11'2"	5.2 m <sup>3</sup> 6.8 yd <sup>3</sup>	kg lb	22 830* 50,340	22 830* 50,340	33 560* 74,000	24 710 54,490	23 640 52,130	16 930 37,330	17 120 37,750	12 200 26,900

Stick	Bucket	10.5 m 35'0"		12 m 40'0"		13.5 m 45'0"		At Max. Reach		
		Front	Side	Front	Side	Front	Side	Front	Side	
2920 mm 9'5"	5.2 m <sup>3</sup> 6.8 yd <sup>3</sup>	kg lb	—	—	—	—	—	—	8860* 19,540	7920 17,460
3400 mm 11'2"	5.2 m <sup>3</sup> 6.8 yd <sup>3</sup>	kg lb	12 820 28,270	8960 19,760	—	—	—	—	8070* 17,790	7200 15,880

\*Load limited by hydraulic capacity rather than tipping.

**Belgium Sourced**

**385C L ● Heavy Lift ● 10 m (32'10") Reach Boom  
● 750 mm (30") Track Shoes**

Stick	Bucket	4.5 m 15'0"		6 m 20'0"		7.5 m 25'0"		9 m 30'0"		
		Front	Side	Front	Side	Front	Side	Front	Side	
4400 mm 14'4"	2.6 m <sup>3</sup> 3.4 yd <sup>3</sup>	kg lb	—	—	11 420* 25,180	11 420* 25,180	24 480* 53,980	15 940 35,150	19 660* 43,350	12 050 26,570
5500 mm 18'0"	2.0 m <sup>3</sup> 2.6 yd <sup>3</sup>	kg lb	—	—	14 770* 32,570	14 770* 32,570	24 310* 53,600	16 370* 36,100	19 370* 42,710	12 360 27,250

Stick	Bucket	10.5 m 35'0"		12 m 40'0"		13.5 m 45'0"		At Max. Reach		
		Front	Side	Front	Side	Front	Side	Front	Side	
4400 mm 14'4"	2.6 m <sup>3</sup> 3.4 yd <sup>3</sup>	kg lb	15 840 34,930	9370 20,660	12 680 27,960	7370 16,250	10 310 22,730	5820 12,830	8330 18,370	4540 10,010
5500 mm 18'0"	2.0 m <sup>3</sup> 2.6 yd <sup>3</sup>	kg lb	15 950* 35,170	9590 21,150	12 860 28,360	7540 16,630	10 450 23,040	5960 13,140	6390* 14,090	3950 8710

**385C L ● Heavy Lift ● 8.4 m (27'2") GP Boom  
● 650 mm (26") Track Shoes**

Stick	Bucket	4.5 m 15'0"		6 m 20'0"		7.5 m 25'0"		9 m 30'0"		
		Front	Side	Front	Side	Front	Side	Front	Side	
3400 mm 11'2"	3.8 m <sup>3</sup> 5.0 yd <sup>3</sup>	kg lb	—	—	29 120* 64,210	24 370 53,740	25 370* 56,600	17 000 37,490	12 540 27,650	12 540 27,650
4400 mm 14'5"	3.5 m <sup>3</sup> 4.6 yd <sup>3</sup>	kg lb	13 430* 29,610	13 430* 29,610	34 300* 75,630	25 820 56,930	26 260* 57,900	18 150 40,020	21 010* 46,330	13 520 29,810
5500 mm 18'1"	3.5 m <sup>3</sup> 4.6 yd <sup>3</sup>	kg lb	15 780* 34,800	15 780* 34,800	33 500* 75,630	26 360 58,120	25 400* 56,000	18 450 40,680	20 290* 44,740	13 670 30,140

Stick	Bucket	10.5 m 35'0"		12 m 40'0"		13.5 m 45'0"		At Max. Reach		
		Front	Side	Front	Side	Front	Side	Front	Side	
3400 mm 11'2"	3.8 m <sup>3</sup> 5.0 yd <sup>3</sup>	kg lb	15 990 35,260	9490 20,930	—	—	—	—	7340* 16,190	6220 13,720
4400 mm 14'5"	3.5 m <sup>3</sup> 4.6 yd <sup>3</sup>	kg lb	16 880 37,220	10 380 22,890	13 380 29,500	8070 17,790	—	—	6670* 14,710	6300 13,890
5500 mm 18'1"	3.5 m <sup>3</sup> 4.6 yd <sup>3</sup>	kg lb	16 800* 37,040	10 440 23,020	13 400 29,550	8080 17,820	8140* 17,950	6270 13,830	4620* 10,190	4620* 10,190

**385C L ● Heavy Lift ● 7.25 m (23'9") Mass Boom  
● 750 mm (30") Track Shoes**

Stick	Bucket	4.5 m 15'0"		6 m 20'0"		7.5 m 25'0"		9 m 30'0"		
		Front	Side	Front	Side	Front	Side	Front	Side	
2920 mm 9'6"	5.2 m <sup>3</sup> 6.8 yd <sup>3</sup>	kg lb	21 360* 47,100	21 360* 47,100	33 250* 73,320	25 450 56,120	25 570* 56,380	17 540 38,680	20 010* 44,120	12 730 28,070
3400 mm 11'2"	5.2 m <sup>3</sup> 6.8 yd <sup>3</sup>	kg lb	22 830* 50,340	22 830* 50,340	33 560* 74,000	25 550 56,340	25 630* 56,510	17 540 38,680	20 140* 44,410	12 690 27,980

Stick	Bucket	10.5 m 35'0"		12 m 40'0"		13.5 m 45'0"		At Max. Reach		
		Front	Side	Front	Side	Front	Side	Front	Side	
2920 mm 9'6"	5.2 m <sup>3</sup> 6.8 yd <sup>3</sup>	kg lb	—	—	—	—	—	—	8860* 19,540	8290 18,280
3400 mm 11'2"	5.2 m <sup>3</sup> 6.8 yd <sup>3</sup>	kg lb	15 470* 34,110	9360 20,640	—	—	—	—	8070* 17,790	7550 16,650

\*Load limited by hydraulic capacity rather than tipping.



**EXCAVATOR BUCKET CAPACITIES**

Caterpillar rates excavator buckets to conform with both PCSA standard No. 3 and SAE standard J-296. Buckets are rated on both their struck and heaped capacities as follows:

**Struck Capacity**

Volume actually enclosed inside the outline of the sideplates and rear and front bucket enclosures without any consideration for any material supported or carried by the spillplate or bucket teeth.

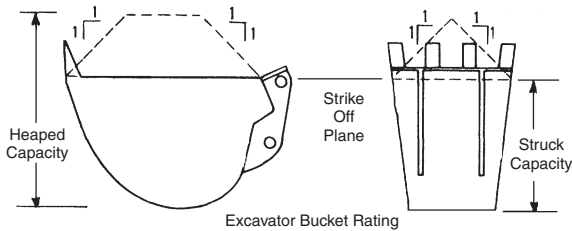

**Heaped Capacity**

Volume in the bucket under the strike off plane plus the volume of the heaped material above the strike off plane, having an angle of repose of 1:1 without any consideration for any material supported or carried by the spillplate or bucket teeth.

The Committee on European Construction Equipment (CECE) rates heaped bucket pay loads on a 2:1 angle of repose for material above the strike off plane.

**CURL AND CROWD FORCES**

Bucket penetration into a material is achieved by the bucket curling force ( $F_B$ ) and stick crowd force ( $F_S$ ). Rated digging forces are the digging forces that can be exerted at the outermost cutting point. These forces can be calculated by applying working relief hydraulic pressure to the cylinder(s) providing the digging force. The digging forces listed on next page conform with SAE Standard J1179 and PCSA Standard No. 3. The values may not be directly comparable to forces for machines rated by other methods than those described below.

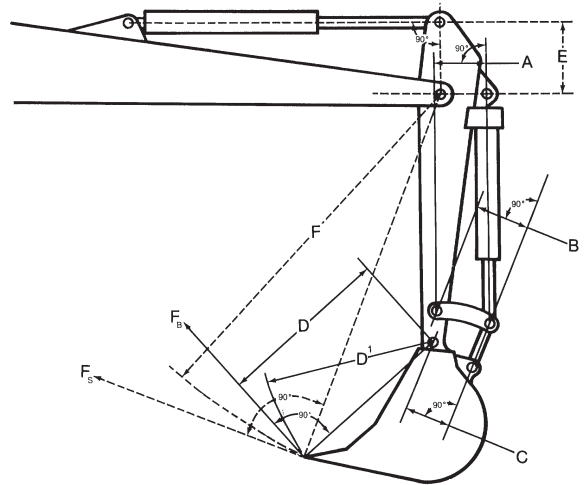

$$F_B = \text{Radial tooth force due to bucket cylinder} \\ = \frac{\text{Bucket cylinder force}}{\text{Arm D length}} \left( \frac{\text{Arm A} \times \text{Arm C}}{\text{Arm B}} \right)$$

$$\text{Cylinder force} = (\text{Pressure}) \times \\ (\text{End area of cylinder head}) \\ \text{Arm D} = \text{Bucket tip radius}$$

Maximum radial tooth force due to bucket cylinder (bucket curling force) is the digging force generated by the bucket cylinder(s) and tangent to the arc of radius  $D^1$ . The bucket shall be positioned to obtain maximum output moment from the bucket cylinder(s) and connecting linkages. When calculating, maximum  $F_B$  occurs when the factor — Arm A times Arm C divided by Arm B — becomes the maximum.

$$F_S = \text{Radial tooth force due to stick cylinder} \\ = \frac{(\text{Stick cylinder force}) \times (\text{Arm E length})}{(\text{Arm F length})}$$

$$\text{Arm F} = \text{Bucket tip radius} + \text{stick length}$$

Maximum radial tooth force due to stick cylinder (stick crowd force) is the digging force generated by the stick cylinder(s) and tangent to the arc of radius F. The stick shall be positioned to obtain the maximum output moment from the arm cylinder and the bucket positioned as described in the bucket force rating. When calculating, maximum  $F_S$  occurs when the axis in the stick cylinder working direction is at a right angle to the line connecting the stick cylinder pin and the boom nose pin.

### Bucket Selection Considering Bucket Curl and Stick Crowd Forces

The combination of the excavator's stick crowd force and bucket curling force give this machine configuration more effective bucket penetration force per mm (inch) of bucket cutting edge than is available with other machine types such as wheel and track loaders.

As a result of high penetration force, an excavator bucket is comparatively easy to load. Also, the higher unit breakout forces allow the excavator's economic application range to be extended farther into the tougher soils (coral, caliche, shale, limestone) before blasting or ripping is required.

To take full advantage of an excavator's high penetration forces, buckets should be selected so they are well matched to soil conditions that are encountered. The two important things to consider are bucket width and bucket tip radius.

As a general rule, wide buckets are used in easily dug soil and narrow buckets in harder material. In hard rocky soils, tip radius also has to be considered in bucket selection. Because the shorter tip radius buckets provide more total bucket curling force than the long tip radius buckets, they are generally the easiest to load. A good rule of thumb when selecting a Cat bucket for hard material is to choose the narrowest bucket that has a short tip radius.

Other factors such as trench bottom width specifications, manbox size, or the desire to conserve bedding material may also influence excavator bucket selection.

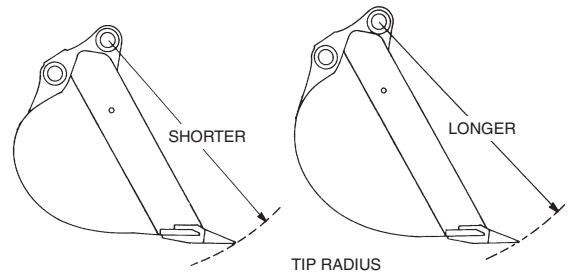

**NOTE:** See the following pages for listing of Cat buckets by tip radius and cutting edge width.

Model	Source	Bucket Tip Radius		Bucket Curling Forces		Stick Crowd Forces							
		mm	ft	kN	lb	Short		Medium		Long		Extra Long	
						kN	lb	kN	lb	kN	lb	kN	lb
301.6C	U.K.	500	1'7"	15.4	3462	9.9	2226	—	—	8.8	1978	—	—
301.8C	U.K.	500	1'7"	15.4	3462	9.9	2226	—	—	8.8	1978	—	—
302.5C	U.K.	650	2'2"	25	5620	15.3	3440	—	—	13.1	2945	—	—
303C CR	Japan	737	2'4"	33	7419	18.9	4249	—	—	16.9	3799	—	—
303.5C CR	Japan	737	2'4"	37.8	8498	21.6	4856	—	—	19.5	4384	—	—
304C CR	Japan	813	2'7"	44.7	10,049	24.7	5553	—	—	21.3	4788	—	—
305C CR	Japan	813	2'7"	50.9	11,443	28.9	6497	—	—	24.8	5575	—	—
305.5	China	900	2'11"	38.6	8678	25.5	5733	—	—	—	—	—	—
307C	Japan	1070	3'6"	44	9830	—	—	35	7850	31	6900	—	—
307D	Japan	1070	3'6"	49.2	11,061	—	—	36.2	8138	—	—	—	—
308D CR	Japan	1014	3'3"	44	9830	—	—	39	8768	—	—	—	—
308D CR SB	Japan	1014	3'3"	60	13,489	—	—	39	8768	—	—	—	—
311D LRR	Japan	1220	4'0"	90	20,175	—	—	60	13,560	55	12,270	52	11,690
312D, 312D L	Japan	1220	4'0"	85	19,100	—	—	64	14,400	60	13,500	57	12,800
312D, 312D L	France	1000	3'3"	96	21,600	66	14,850	62	13,950	59	13,275	—	—
313C SR	Japan	1220	4'0"	88	19,780	—	—	63	14,160	—	—	—	—
313C CR	Japan	1220	4'0"	94	21,120	—	—	64	14,380	57	12,810	—	—
314D CR, 314D LCR	Japan	1220	4'0"	85	19,100	—	—	64	14,400	60	13,500	57	12,800

**Japan Sourced  
315D L**

Boom		1-Piece Boom			
Stick		Short	Medium	Long	Extra Long
Bucket Tip Radius	mm ft	1350 4'5"	1350 4'5"	1350 4'5"	1350 4'5"
Bucket Curling Forces	kN lb	100 22,530	100 22,530	100 22,530	100 22,530
Stick Crowd Forces	kN lb	85 19,200	78 17,470	73 16,410	70 15,670

**Japan/France Sourced  
315D L (EAME)**

Boom		1-Piece Boom			
Stick		Short	Medium	Long	Extra Long
Bucket Tip Radius	mm ft	1117 3'7"	1117 3'7"	1117 3'7"	1117 3'7"
Bucket Curling Forces	kN lb	102 22,930	90 20,230	82 18,430	74 16,630
Stick Crowd Forces	kN lb	98 22,030	80 17,980	69 15,510	62 13,930

**France Sourced  
319D L, 319D LN**

Boom		1-Piece Boom			
Stick		Short	Medium	Long	Extra Long
Bucket Tip Radius	mm ft	1461 4'10"	1461 4'10"	1461 4'10"	1461 4'10"
Bucket Curling Forces	kN lb	148 33,300	146 32,850	124 27,900	126 28,350
Stick Crowd Forces	kN lb	125 28,125	108 24,300	92 20,700	83 18,675

**M313D**

Boom		1-Piece/VA Boom			
Stick		2300 mm	7'5"	2600 mm	8'6"
Bucket Tip Radius	mm ft	1236 4'1"		1236 4'1"	
Bucket Curling Forces	kN lb	93 20,925		93 20,925	
Stick Crowd Forces	kN lb	67 15,075		62 13,950	

**M315D, M316D**

Boom		1-Piece/VA Boom			
Stick		2400 mm	7'10"	2600 mm	8'6"
Bucket Tip Radius	mm ft	1405 4'7"		1405 4'7"	
Bucket Curling Forces	kN lb	101 22,725		101 22,725	
Stick Crowd Forces	kN lb	74 16,650		71 15,975	

**M318D**

Boom		1-Piece/VA Boom			
Stick		2500 mm	8'2"	2800 mm	9'2"
Bucket Tip Radius	mm ft	1405 4'7"		1405 4'7"	
Bucket Curling Forces	kN lb	126 28,350		126 28,350	
Stick Crowd Forces	kN lb	91 20,475		85 19,125	

**M322D**

Boom		1-Piece/VA Boom			
Stick		2500 mm	8'2"	2900 mm	9'6"
Bucket Tip Radius	mm ft	1511 4'11"		1511 4'11"	
Bucket Curling Forces	kN lb	140 31,500		140 31,500	
Stick Crowd Forces	kN lb	114 25,650		104 23,400	

**Europe/Africa/Middle East Sourced  
320D, 320D L**

Boom		Reach Boom	
Stick		Medium (R2.5B)	Long (R2.9B)
Bucket Tip Radius	mm ft	1554 5'1"	1554 5'1"
Bucket Curling Forces	kN lb	141 31,725	141 31,725
Stick Crowd Forces	kN lb	118 26,650	106 23,850

4

**Europe/Africa/Middle East Sourced  
320D RR**

Boom		Reach Boom	
Stick		Medium	Long
Bucket Tip Radius	mm ft	1554 5'1"	1554 5'1"
Bucket Curling Forces	kN lb	141 31,725	141 31,725
Stick Crowd Forces	kN lb	118 26,650	106 23,850

## Excavators

### Curl and Crowd Forces

- 320D
- 320D L
- 320D RR
- 320D LRR
- 321D LCR
- SAE

### Japan/China/Indonesia/Brazil Sourced 320D, 320D L per SAE

Boom		Reach Boom			Mass Boom
Stick		Medium (R2.5B)	Long (R2.9B)	Extra Long (R3.9B)	Medium
Bucket Tip Radius	mm	1477	1477	1477	1555
	ft	4'10"	4'10"	4'10"	4'11"
Bucket Curling Forces	kN	131	131	131	166
	lb	29,450	29,450	29,450	37,318
Stick Crowd Forces	kN	117	105	86	125
	lb	26,303	23,605	19,334	28,100

### Japan Sourced 320D RR, 320D LRR per SAE

Boom		Reach Boom		
Stick		Medium	Long	Extra Long
Bucket Tip Radius	mm	1477	1477	1477
	ft	4'10"	4'10"	4'10"
Bucket Curling Forces	kN	131	131	131
	lb	29,450	29,450	29,450
Stick Crowd Forces	kN	117	105	86
	lb	26,303	23,605	19,334

### Japan Sourced 321D LCR

Boom		Reach Boom	Reach Boom/VA Boom
Stick		Long	Long
Bucket Tip Radius	mm	1477	1554
	ft	4'10"	5'1"
Bucket Curling Forces	kN	131	141
	lb	29,450	31,725
Stick Crowd Forces	kN	105	106
	lb	23,605	26,650

### Europe/Africa/ Middle East Sourced 321D LCR

**Belgium/Brazil/France Sourced  
323D L**

Boom		Reach Boom		
Stick		R1.9CB	R2.5B1	R2.9B1
Bucket Tip Radius	mm ft	1610 5'3"	1554 5'1"	1554 5'1"
Bucket Curling Forces	kN lb	179 40,275	141 31,725	141 31,725
Stick Crowd Forces	kN lb	147 33,075	118 26,550	106 26,650
Boom		Mass Boom		
Stick		M2.4CB2		
Bucket Tip Radius	mm ft	1610 5'3"		
Bucket Curling Forces	kN lb	188 42,300		
Stick Crowd Forces	kN lb	130 29,250		
Boom		VA Boom		
Stick		R1.9CB	R2.5B1	R2.9B1
Bucket Tip Radius	mm ft	1610 5'3"	1554 5'1"	1554 5'1"
Bucket Curling Forces	kN lb	179 40,275	141 31,725	141 31,725
Stick Crowd Forces	kN lb	147 33,075	118 26,550	106 26,650

**China Sourced  
323D L**

Boom		Reach Boom	
Stick		R2.5B1	R2.9B1
		B1360HD-CXL	
Bucket Tip Radius	mm ft	1579 5'2"	1579 5'2"
Bucket Curling Forces	kN lb	140.4/124.9 31,563/28,079	140.4/124.9 31,563/28,079
Stick Crowd Forces	kN lb	117.9/113.9 26,505/25,606	106.4/103.2 23,920/23,200
Boom		Mass Boom	
Stick		M2.4CB2	
Bucket Tip Radius	mm ft	1683 5'6"	
Bucket Curling Forces	kN lb	174.2/155.1 39,162/34,868	
Stick Crowd Forces	kN lb	126.4/121.7 28,416/27,359	



**Japan/U.S. Sourced  
324D**

Boom		Reach Boom		
Stick		Medium	Long	Extra Long
Bucket Tip Radius	mm ft	1551 5'1"	1551 5'1"	1477 4'10"
Bucket Curling Forces	kN lb	186 41,814	186 41,814	172 38,667
Stick Crowd Forces	kN lb	148 33,272	127 28,551	113 25,471
Boom		Mass Boom		
Stick		Short	Medium	
Bucket Tip Radius	mm ft	1663 5'5"	1663 5'5"	
Bucket Curling Forces	kN lb	189 42,470	239 53,729	
Stick Crowd Forces	kN lb	151 33,930	147 33,047	

**Belgium Sourced  
324D L, 324D LN, 324D L VA**

Boom		Reach Boom	
Stick		R2.5CB1	R2.95CB1
Bucket Tip Radius	mm ft	1610 5'3"	1610 5'3"
Bucket Curling Forces	kN lb	160 36,000	149 33,525
Stick Crowd Forces	kN lb	149 33,525	132 29,700
Boom		Mass Boom	
Stick		M2.0DB	M2.5DB
Bucket Tip Radius	mm ft	2000 6'7"	2500 8'2"
Bucket Curling Forces	kN lb	186 41,850	177 39,825
Stick Crowd Forces	kN lb	171 38,475	154 34,650
Boom		VA Boom	
Stick		M2.5CB1	M2.9CB1
Bucket Tip Radius	mm ft	2500 8'2"	2950 9'8"
Bucket Curling Forces	kN lb	160 36,000	149 33,525
Stick Crowd Forces	kN lb	149 33,525	132 29,700

**Japan/U.S. Sourced  
328D LCR**

Boom		Reach Boom	
Stick		Short	Medium
Bucket Tip Radius	mm ft	1660 5'5"	1487 4'11"
Bucket Curling Forces	kN lb	201 45,187	200 44,962
Stick Crowd Forces	kN lb	152 34,171	133 29,900

**Japan/U.S. Sourced  
329D**

Boom		Reach Boom			
Stick		Short	Medium	Long	Extra Long
Bucket Tip Radius	mm ft	1660 5'5"	1487 4'11"	1487 4'11"	1488 4'11"
Bucket Curling Forces	kN lb	201 45,187	200 44,962	201 45,187	160 36,000
Stick Crowd Forces	kN lb	152 34,171	133 29,900	120 26,977	124 27,900

Boom		Mass Boom	
Stick		Medium	
Bucket Tip Radius	mm ft	1660 5'5"	1660 5'5"
Bucket Curling Forces	kN lb	239 53,729	239 53,729
Stick Crowd Forces	kN lb	162 36,419	162 36,419

**Belgium Sourced  
329D**

Boom		Reach Boom		
Stick		R2.0DB	R2.6CB2	R3.2CB2
Bucket Tip Radius	mm ft	1764 5'9"	1610 5'3"	1610 5'3"
Bucket Curling Forces	kN lb	198 44,550	168 37,800	159 35,775
Stick Crowd Forces	kN lb	188 42,300	155 34,875	138 31,050

Boom		Mass Boom	VA Boom		
Stick		M2.5DB	M2.0DB	M2.6CB2	R3.2CB2
Bucket Tip Radius	mm ft	2500 8'2"	1764 5'9"	1610 5'3"	1610 5'3"
Bucket Curling Forces	kN lb	185 41,625	198 44,550	168 37,800	159 35,775
Stick Crowd Forces	kN lb	167 37,575	188 42,300	155 34,875	138 31,050

**Japan/U.S. Sourced  
336D**

Boom		Reach Boom			
Stick		Short	Medium	Long	Extra Long
Bucket Tip Radius	mm ft	1845 6'0"	1660 5'5"	1660 5'5"	1660 5'5"
Bucket Curling Forces	kN lb	238 53,437	238 53,572	190 42,700	191 42,900
Stick Crowd Forces	kN lb	170 38,218	152 34,148	161 36,200	140 31,500
Boom		Mass Boom			
Stick		M2.6E			
Bucket Tip Radius	mm ft	1845 6'1"			
Bucket Curling Forces	kN lb	271 60,923			
Stick Crowd Forces	kN lb	195 43,883			

**Belgium Sourced  
336D L**

Boom		Reach Boom			
Stick		R2.1TB	R2.8DB	R3.2DB	R3.9DB
Bucket Tip Radius	mm ft	1897 6'3"	1761 5'9"	1761 5'9"	1761 5'9"
Bucket Curling Forces	kN lb	249 56,025	204 45,900	194 43,650	184 41,400
Stick Crowd Forces	kN lb	235 52,875	194 43,650	177 39,825	158 35,550
Boom		Mass Boom			
Stick		M2.15TB		M2.6TB	
Bucket Tip Radius	mm ft	1897 6'3"		1897 6'3"	
Bucket Curling Forces	kN lb	249 56,025		233 52,425	
Stick Crowd Forces	kN lb	235 52,875		208 46,800	

### Japan Sourced 345D per SAE

Boom		Reach Boom		
Stick		Short	Medium	Long
Bucket Tip Radius	mm ft	1725 5'8"	1725 5'8"	1725 5'8"
Bucket Curling Forces	kN lb	258 58,000	258 58,000	258 58,000
Stick Crowd Forces	kN lb	220 49,500	201 45,100	186 41,800
Boom		Mass Boom		
Stick		Short	Medium	
Bucket Tip Radius	mm ft	2050 6'9"	2050 6'9"	
Bucket Curling Forces	kN lb	203 45,680	203 45,680	
Stick Crowd Forces	kN lb	228 51,300	203 45,680	

### Japan Sourced 345D

Boom		Reach Boom		
Stick		Short	Medium	Long
Bucket Tip Radius	mm ft	1820 6'0"	1820 6'0"	1820 6'0"
Bucket Curling Forces	kN lb	234 52,580	234 52,580	234 52,580
Stick Crowd Forces	kN lb	216 48,540	197 44,270	183 41,120
Boom		Mass Boom		
Stick		Medium	Long	
Bucket Tip Radius	mm ft	2020 6'8"	2020 6'8"	
Bucket Curling Forces	kN lb	263 59,100	263 59,100	
Stick Crowd Forces	kN lb	230 51,690	204 45,840	

**Japan/U.S. Sourced  
345D L – FIX**

<b>Boom</b>		<b>Long Reach Boom</b>		
<b>Stick</b>		<b>Long</b>		<b>Extra Long</b>
Bucket Tip Radius	mm	1820		1820
	ft	6'0"		6'0"
Bucket Curling Forces	kN	234		235
	lb	52,580		52,810
Stick Crowd Forces	kN	183		170
	lb	41,120		38,200
<b>Boom</b>		<b>Reach Boom</b>		
<b>Stick</b>		<b>Short</b>	<b>Medium</b>	<b>Long</b>
Bucket Tip Radius	mm	1820	1820	1820
	ft	6'0"	6'0"	6'0"
Bucket Curling Forces	kN	234	234	234
	lb	52,580	52,580	52,580
Stick Crowd Forces	kN	216	197	183
	lb	48,540	44,270	41,120
<b>Boom</b>		<b>Mass Boom</b>		
<b>Stick</b>		<b>Medium</b>		<b>Long</b>
Bucket Tip Radius	mm	2020		2020
	ft	6'8"		6'8"
Bucket Curling Forces	kN	263		263
	lb	59,100		59,100
Stick Crowd Forces	kN	230		204
	lb	51,690		45,840

**345D L – VG**

<b>Boom</b>		<b>Long Reach Boom</b>		
<b>Stick</b>		<b>Long</b>		<b>Extra Long</b>
Bucket Tip Radius	mm	1820		1820
	ft	6'0"		6'0"
Bucket Curling Forces	kN	234		235
	lb	52,580		52,810
Stick Crowd Forces	kN	183		170
	lb	41,120		38,200
<b>Boom</b>		<b>Reach Boom</b>		
<b>Stick</b>		<b>Short</b>	<b>Medium</b>	<b>Long</b>
Bucket Tip Radius	mm	1820	1820	1820
	ft	6'0"	6'0"	6'0"
Bucket Curling Forces	kN	234	234	234
	lb	52,580	52,580	52,580
Stick Crowd Forces	kN	216	197	183
	lb	48,540	44,270	41,120
<b>Boom</b>		<b>Mass Boom</b>		
<b>Stick</b>		<b>Medium</b>		<b>Long</b>
Bucket Tip Radius	mm	2020		2020
	ft	6'8"		6'8"
Bucket Curling Forces	kN	263		263
	lb	59,100		59,100
Stick Crowd Forces	kN	230		204
	lb	51,690		45,840

**Belgium Sourced  
 345D L per ISO**

Boom		Reach Boom		Mass Boom	
Stick		R2.9TB	R3.35TB	M2.5UB	M3.0UB
Bucket Tip Radius	mm ft	1704 5'7"	1704 5'7"	1862 6'1"	1862 6'1"
Bucket Curling Forces	kN lb	249 56,030	239 53,780	275 61,875	261 58,725
Stick Crowd Force	kN lb	235 52,880	217 48,830	259 58,050	234 52,430

**Belgium Sourced  
 365C L per ISO**

Boom		7.80 m (25'7") Reach Boom			
Stick		R2.84VB	R3.6VB	R4.15VB	R4.67VB
Bucket Tip Radius	mm ft	1903 6'2"	1862 5'9"	1862 5'9"	1862 5'9"
Bucket Curling Forces	kN lb	295 66,380	284 63,900	271 60,980	264 59,400
Stick Crowd Forces	kN lb	287 64,580	265 59,630	243 54,680	229 51,530
Boom		6.6 m (21'8") Mass Boom		7 m (23'0") Mass Boom	
Stick		M2.57WB	M3.0WB	M2.57WB	M3.0WB
Bucket Radius at Cutting Edge	mm ft	2015 6'6"	2015 6'6"	2015 6'6"	2015 6'6"
Bucket Force	kN lb	332 74,700	321 72,230	332 74,700	321 72,230
Stick Force	kN lb	309 69,530	289 65,030	309 69,530	288 64,800

- 385C/385C L
- ISO

**Belgium Sourced  
385C/385C L per ISO**

<b>Boom</b>		<b>Reach Boom 10 m (32'10")</b>		
<b>Stick</b>		<b>R4.4HB</b>		<b>R5.5HB</b>
Bucket Radius at Cutting Edge	<b>mm</b> <b>ft</b>	1959 <b>6'5"</b>		1959 <b>6'5"</b>
Bucket Digging Force	<b>kN</b> <b>lb</b>	335 <b>75,380</b>		316 <b>71,100</b>
Stick Digging Force	<b>kN</b> <b>lb</b>	293 <b>65,930</b>		256 <b>57,600</b>
<b>Boom</b>		<b>General Purpose Boom 8.4 m (27'2")</b>		
<b>Stick</b>		<b>G3.4JB</b>	<b>G4.4HB</b>	<b>G5.5HB</b>
Bucket Radius at Cutting Edge	<b>mm</b> <b>ft</b>	2175 <b>7'2"</b>	1959 <b>6'5"</b>	1959 <b>6'5"</b>
Bucket Digging Force	<b>kN</b> <b>lb</b>	384 <b>86,400</b>	334 <b>75,150</b>	315 <b>70,880</b>
Stick Digging Force	<b>kN</b> <b>lb</b>	342 <b>76,950</b>	293 <b>65,930</b>	257 <b>57,830</b>
<b>Boom</b>		<b>Mass Boom 7.25 m (23'9")</b>		
<b>Stick</b>		<b>M2.92JB</b>		<b>M3.4JB</b>
Bucket Radius at Cutting Edge	<b>mm</b> <b>ft</b>	2233 <b>7'4"</b>		2233 <b>7'4"</b>
Bucket Digging Force	<b>kN</b> <b>lb</b>	394 <b>88,650</b>		385 <b>86,630</b>
Stick Digging Force	<b>kN</b> <b>lb</b>	362 <b>81,450</b>		344 <b>77,400</b>

Caterpillar offers a very comprehensive list of high strength steel buckets. High strength steel allows thinner components which helps keep the weight down, maintains durability and improves loadability. The wrong bucket can reduce production 30-40% or more. Caterpillar's in-depth knowledge of machine design, bucket design and application experience

allows offering **machine matched** packages that optimize performance.

Additional buckets may be available and the listed buckets may not be available in all sales areas. Contact your Cat dealer for your specific bucket needs.

Model	Bucket Type	Teeth	Bucket Bite Width		Bucket Tip Radius		Heaped Capacity		Bucket Weight With Teeth		
			mm	in	mm	in	L	yd <sup>3</sup>	kg	lb	
301.6C, 301.8C	Digging	0	230	9.0	440	17.0	18	0.023	25	55	
		3	230	9.0	500	20.0	18	0.023	29	64	
		0	300	12.0	440	17.0	22	0.029	27	60	
		3	300	12.0	500	20.0	22	0.029	31	68	
		0	400	16.0	440	17.0	33	0.043	31	68	
		3	400	16.0	500	20.0	33	0.043	35	77	
		0	457	18.0	440	17.0	40	0.052	34	75	
		3	457	18.0	500	20.0	40	0.052	38	84	
		0	500	20.0	440	17.0	45	0.059	36	79	
		4	500	20.0	500	20.0	45	0.059	41	90	
		0	600	24.0	440	17.0	56	0.073	40	88	
		4	600	24.0	500	20.0	56	0.073	45	99	
		Ditching	0	800	32.0	353	14.0	44	0.057	41	90
			0	1000	40.0	353	14.0	56	0.073	43	95
302.5C	Digging	0	260	10.0	568	22.0	35	0.046	43	96	
		3	260	10.0	640	26.0	35	0.046	48	105	
		0	300	12.0	568	22.0	41	0.053	44	97	
		3	300	12.0	640	26.0	41	0.053	51	112	
		0	400	16.0	568	22.0	54	0.070	49	107	
		3	400	16.0	640	26.0	54	0.070	55	121	
		0	457	18.0	568	22.0	65	0.085	53	116	
		3	457	18.0	650	26.0	65	0.085	59	130	
		0	500	20.0	568	22.0	73	0.095	55	122	
		4	500	20.0	640	26.0	73	0.095	64	140	
		0	600	24.0	568	22.0	92	0.120	62	136	
		4	600	24.0	640	26.0	92	0.120	70	155	
		0	700	28.0	568	22.0	111	0.145	69	152	
		4	700	28.0	640	26.0	111	0.145	77	170	
Ditching	0	800	32.0	482	19.0	80	0.105	82	178		
	0	1000	40.0	482	19.0	102	0.133	78	172		
	0	1200	48.0	482	19.0	116	0.217	88	193		



Model	Bucket Type	Teeth	Bucket Bite Width		Bucket Tip Radius		Heaped Capacity		Bucket Weight With Teeth	
			mm	in	mm	in	L	yd <sup>3</sup>	kg	lb
303C CR, 303.5C CR	Digging	3	300	12.0	737	29.0	48	0.06	63	139
		3	400	16.0	737	29.0	69	0.09	72	158
		4	457	18.0	737	29.0	82	0.11	80	176
		5	500	20.0	737	29.0	94	0.12	88	193
		5	600	24.0	737	29.0	119	0.15	99	217
		5	750	30.0	737	29.0	157	0.20	115	253
304C CR, 305C CR	Digging	3	300	12.0	813	32.0	57	0.07	69	151
		3	400	16.0	813	32.0	75	0.10	77	169
		4	457	18.0	813	32.0	89	0.11	86	189
		5	500	20.0	813	32.0	103	0.13	94	207
		5	600	24.0	813	32.0	130	0.17	106	234
		5	750	30.0	813	32.0	172	0.23	125	274
		6	915	36.0	813	32.0	215	0.28	145	319
		3	300	12.0	880	34.6	81	0.11	82	179
		3	400	16.0	880	34.6	105	0.14	91	200
		4	457	18.0	880	34.6	124	0.16	100	220
		5	500	20.0	880	34.6	143	0.19	109	241
		5	600	24.0	880	34.6	182	0.24	123	271
		5	750	30.0	880	34.6	242	0.32	144	316
		6	915	36.0	880	34.6	301	0.39	166	366
307D, 308D CR, 308D CR SB	Heavy Duty	3	330	13.0	1014	40.0	99	0.13	125	276
		4	457	18.0	1014	40.0	153	0.20	151	333
		4	610	24.0	1014	40.0	229	0.30	178	392
		5	762	30.0	1014	40.0	306	0.40	207	455
		5	914	36.0	1014	40.0	390	0.51	230	507
		5	914	36.0	1014	40.0	390	0.51	230	507
	Heavy Duty Rock	4	610	24.0	1014	40.0	229	0.30	194	427
		5	762	30.0	1014	40.0	306	0.40	223	490
	Ditch Cleaning	0	1219	48.0	787	31.0	329	0.43	216	476
		0	1372	54.0	787	31.0	375	0.49	235	516
		0	1524	60.0	787	31.0	421	0.55	253	556
		0	1500	59.1	659	26.0	237	0.31	145	320
		0	1800	70.9	659	26.0	298	0.39	166	366

## **NEW NOMENCLATURE FOR HYDRAULIC EXCAVATOR BUCKETS**

Caterpillar will soon be moving to a new global nomenclature for buckets on small, medium and large HEX machines and associated linkages. The end result will be a manageable, consistent bucket offering in all regions regardless of where the machine or bucket may be built and shipped. The new bucket designs and nomenclature will be introduced over the next several years, as D and E Series HEX machines are introduced.

### **Why the change?**

#### **Consistent product line**

Buckets currently sold into different regions of the world have been designed and manufactured independent of each other resulting in different bucket styles and nomenclature. As Caterpillar becomes more global, we recognize this can lead to confusion in the marketplace as machines and buckets are sourced from different areas.

### **Improved bucket selection**

Caterpillar continues to recognize the need for a range of buckets for various applications and with varying durability requirements — from site development to granite quarries. The new, global nomenclature is simplified, consistent, and based on the durability of the bucket. These considerations allow a clear and consistent bucket positioning to help facilitate appropriate bucket selection and recommendation — and put Caterpillar in a better position to support machines on a global scale.

Dealers and customers in North America will see changes in bucket nomenclature and improvement in bucket designs.

### **What dealers will see with the change**

Today, North American HEX buckets are grouped into three main categories: General Purpose (GP), Heavy Duty (HD), and Heavy Duty Rock (HDR). New nomenclature brings in four primary categories, each represent durability. They are: General Duty (GD), Heavy Duty (HD), Severe Duty (SD), and Extreme Duty (XD). Within the Extreme Duty class a new bucket specific for use in granite will be available for the large excavators.

The diagram below illustrates how today's nomenclature aligns with the new, followed by a brief description of each category.

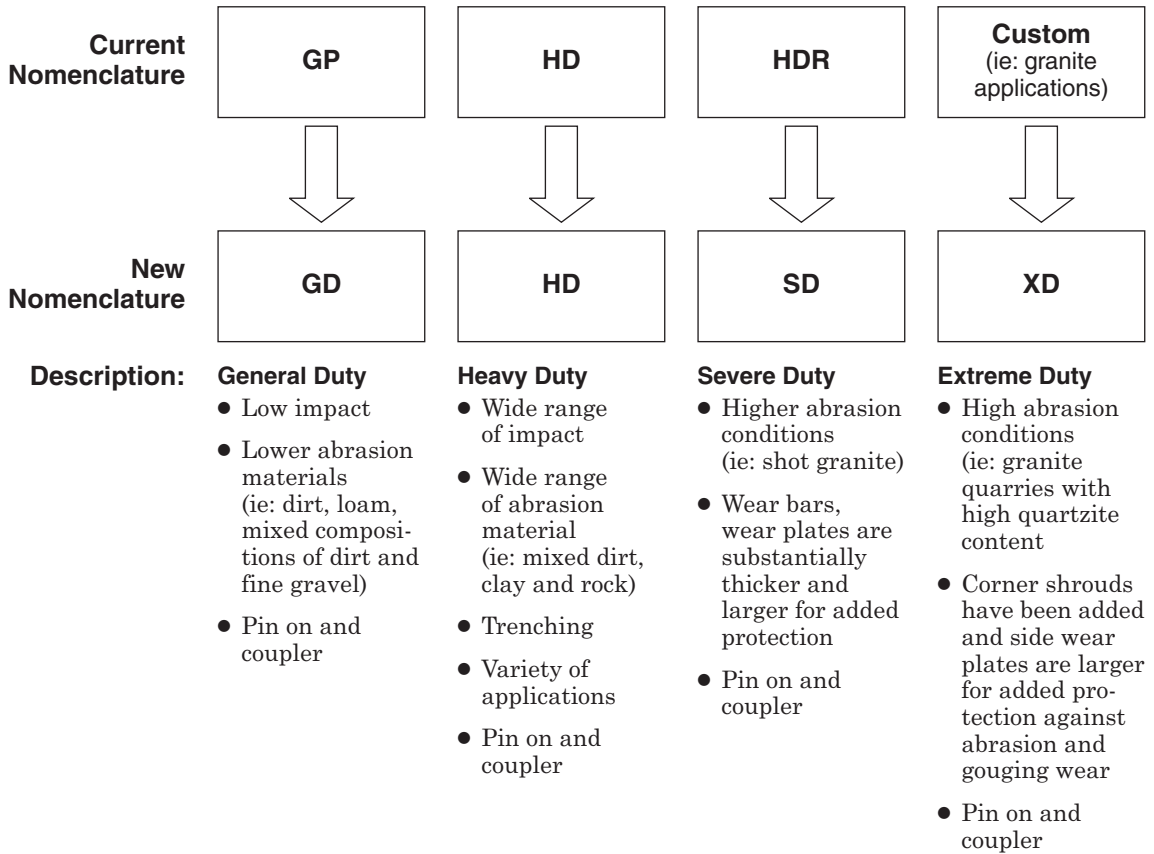

## BUCKET TYPES

### General Duty

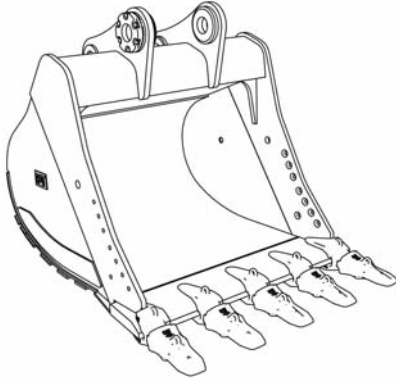

For digging in low impact, lower abrasion materials such as dirt, loam, and mixed compositions of dirt and fine gravel. Example: Digging conditions in which General Duty tip life exceeds 800 hours.

Typically larger General Duty buckets are the most popular sizes, and are used by site developers to mass excavate in low abrasion applications.

- Lighter structures decrease load time and increase the weight that can be lifted.
- Standard size adapters and tips.
- Sidebars are pre-drilled for optional sidecutters and sidebar protectors.

### Heavy Duty

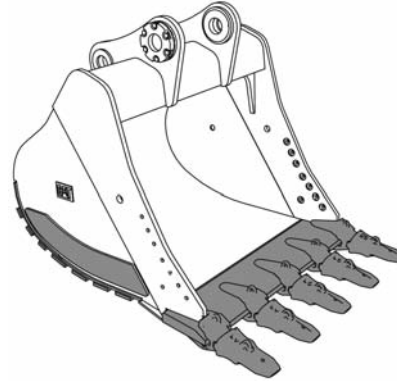

The most popular excavator bucket style. A good “center line” choice, or starting point, when application conditions are not well known.

For a wide range of impact and abrasion conditions including mixed dirt, clay and rock. Example: Digging conditions where Penetration Plus tip life ranges from 400 to 800 hours.

Heavy Duty Buckets are recommended for trenching in utilities work, and for the general contractor working in a variety of different situations.

- Thicker bottom and side wear plates than General Duty buckets for more durability.
- Adapters and tips are up-sized for enhanced performance and durability.
- Sidebars are pre-drilled for optional sidecutters and sidebar protectors.

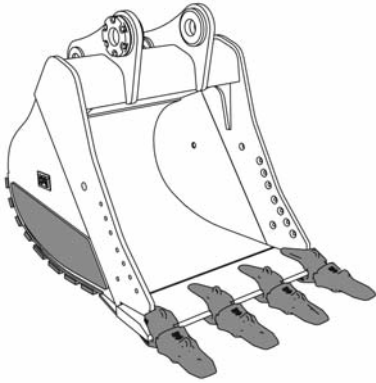
**Severe Duty**

For higher abrasion conditions such as well shot granite and caliche. Example: Digging conditions where tip life ranges from 200 to 400 hours with Penetration Plus tips.

- Bottom wear plates are about 50% thicker than Heavy Duty buckets.
- Side wear plates are about 40% larger than Heavy Duty buckets for added protection against abrasive and gouging wear.
- Heavy Duty and Severe Duty buckets use same size adapters.
- Adapters are sized to accommodate higher abrasion conditions.
- Tips are up-sized (over the General Duty bucket) for enhanced performance and durability.
- Sidebars are pre-drilled for optional sidecutters and sidebar protectors.

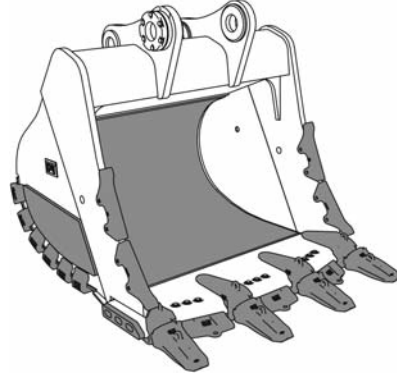
**Extreme Duty**

For very high abrasion conditions including high quartzite granite. Example: Digging conditions where tip life is less than or equal to 200 hours with Extra Duty tips.

- Corner (or heel) shrouds, Base Edge End Protectors (BEEPs), base edge segments, liners, and Mechanically Attached Wear Plates (MAWPs) protect the bucket from wear.
- Side wear plates are larger.
- Sidebar protection has been added for protection against abrasion and gouging wear.
- Adapters are sized to accommodate higher abrasion conditions.
- Tips are up-sized (over the General Duty bucket) for enhanced performance and durability.

### Special Purpose Buckets

Caterpillar offers a range of special purpose buckets, variants of the durabilities listed above, to meet particular application needs.

#### Ditch Cleaning



These buckets are designed for cleaning ditches, sloping, grading and other finish work. Their shallow depth and compact size make working in confined areas easier. Drainage holes allow liquid to empty so material dumps more easily.

#### Ditch Cleaning Tilt

Tilt Buckets feature a full 45° of tilt in each direction, powered by two double-acting cylinders. Ditch Cleaning and Tilt Buckets are available for 311-336 excavators.

### Center-Lock™ Pin Grabber Performance



This bucket is designed with a patented recessed pin to provide maximum digging performance while keeping the versatility and convenience of a coupler. Tip radius is reduced and allows up to 10% improvement in breakout force when compared to a conventional pin on Bucket and Coupler combination.

Center-Lock Performance Buckets are available for 315-345 excavators, in General Duty, Heavy Duty and Extreme Duty durabilities.

**Power**

Power Buckets are for use in abrasive applications where breakout force and cycle times are critical — and for use in materials such as tightly compacted mixed dirt and rock. (Not recommended for clay.) Breakout force is maximized due to decreased tip radius and increased pin spread. Machine cycle times in most material is improved over a standard bucket in a similar application. Heavy Duty Power Buckets are available for 320-345 excavators.

**Wide Tip**

Wide Tip Buckets are intended to perform best in low-impact materials such as dirt and loam where leaving a smoother floor and minimal spillage is necessary. The bucket is engineered to be used exclusively with Cat Wide Tips. Corner adapters face straight forward to create a smooth edge. General Purpose Wide Tip Buckets are available in widths from 24" to 78" for 311-345 excavators.

## High Capacity



High Capacity Buckets are designed and built for use in high production truck loading applications. With proper application and set up, these buckets will move more material in a minimal amount of passes — maximizing production. High Capacity Buckets are available for 374 excavators, in General Duty durability.

## BUCKET SALES SUPPORT

The latest sales literature for HEX Buckets worldwide can be found in the new Global Sales Library at <https://gsl.cat.com>. Documents to look for:

- HEX Bucket Specalog (NACD) — GEHQ0201
- 374D Buckets Product Bulletin — GEJQ0231



## Excavators

### Working Weights

- Bucket Fill Factors
- Bucket & Payload

### BUCKET PAYLOAD

An excavator's bucket payload (actual amount of material in the bucket on each digging cycle) is dependent on bucket size, shape, curl force, and certain soil characteristics, i.e., the fill factor for that soil. Fill factors for several types of material are listed below.

$$\text{Average Bucket Payload} = (\text{Heaped Bucket Capacity}) \times (\text{Bucket Fill Factor})$$

Material	Fill Factor Range (Percent of heaped bucket capacity)
Moist Loam or Sandy Clay	A — 100-110%
Sand and Gravel	B — 95-110%
Hard, Tough Clay	C — 80-90%
Rock — Well Blasted	60-75%
Rock — Poorly Blasted	40-50%

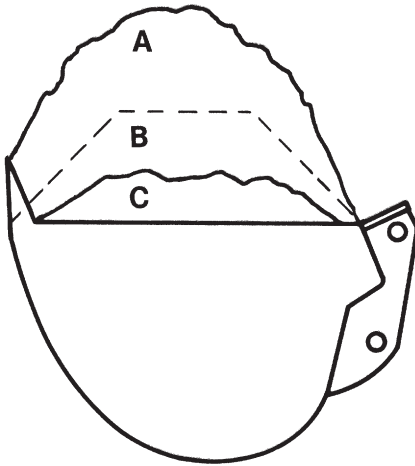

### Working Weights — Bucket & Payload

*The following tables give maximum “bucket plus payload” weights to assist in selecting the correct bucket for a specific application. These weights are based on actual job conditions. In better than average conditions the excavator may be able to achieve rated lift capacities listed in this section.*

**NOTE:** Bucket sizes are suitable for a maximum material density of 1800 kg/m<sup>3</sup> (3035 lb/yd<sup>3</sup>). Payloads shown are calculated at 1500 kg/m<sup>3</sup> (2530 lb/yd<sup>3</sup>).

Model	Boom	Stick Length		Working Weights† Buckets & Payload	
		m	ft	kg	lb
301.6C/ 301.8C	Swing	0.89	2'11"	234	516
		1.09	3'6"	210	463
302.5C	Swing	1.11	3'7"	—	—
		1.40	4'4"	—	—
303C CR	Swing	1.26	4'2"	274	604
		1.56	5'1"	225	496
303.5C CR	Swing	1.32	4'4"	274	604
		1.62	5'4"	225	496
304C CR	Swing	1.38	4'6"	513	1130
		1.78	5'10"	464	1020
305C CR	Swing	1.43	4'8"	513	1130
		1.83	6'0"	464	1020
307C	Fixed	1.67	5'6"	1153	2540
		2.21	7'3"	946	2090
307D	Fixed	1.67	5'6"	1153	2540
		2.21	7'3"	946	2090
308D CR	Swing	1.67	5'6"	1100	2430
		2.21	7'3"	899	1980
308D CR SB	Swing	1.67	5'6"	1100	2430
		2.21	7'3"	899	1980
311D LRR	Reach	2.25	7'5"	1537	3390
		2.60	8'6"	1295	2850
		2.80	9'2"	1295	2850
312D	Reach	2.10	6'11"	1720	3790
		2.50	8'2"	1592	3510
		2.80	9'2"	1402	3090
		3.00	9'10"	1402	3090
312D L	Reach	2.10	6'11"	1764	3890
		2.50	8'2"	1633	3600
		2.80	9'2"	1439	3170
		3.00	9'10"	1439	3170
313C SR	Parallel Offset	2.13	7'0"	2060	4540
		2.13	7'0"	1537	3390
313C CR	Reach	2.50	8'2"	1240	2730
		3.00	9'10"	1075	2370

†Working weights may vary depending on machine configuration and geographic location. Contact your Cat dealer for specific information.

Model	Boom	Stick Length		Working Weights† Buckets & Payload	
		m	ft	kg	lb
314D CR		2.50	8'2"	1538	3390
		2.80	9'2"	1351	2980
		3.00	9'10"	1351	2980
314D LCR	Reach	2.50	8'2"	1560	3440
		2.80	9'2"	1372	3020
		3.00	9'10"	1372	3020
315D L	Reach	1.85	6'1"	2141	4720
		2.25	7'5"	2018	4450
		2.60	8'6"	1862	4110
		2.90	9'6"	1719	3790
		3.10	10'2"	1719	3790
319D L		1.80	5'11"	3158	6963
		2.25	7'5"	2883	6357
		2.70	8'10"	2649	5841
		3.20	10'6"	2309	5091
319D LN		1.80	5'11"	2759	6084
		2.25	7'5"	2522	5561
		2.70	8'10"	2317	5109
		3.20	10'6"	2010	4432
320D	Reach	1.90	6'3"	2450	5390
		2.50	8'2"	2560	5632
		2.90	9'7"	2460	5412
		3.90	12'10"	2020	4444
	Mass	2.40	7'10"	2730	6006
320D L	Reach	1.90	6'3"	2850	6270
		2.50	8'2"	2900	6380
		2.90	9'7"	2750	6050
		3.90	12'10"	2320	5104
	Mass	2.40	7'10"	3170	6974
320D RR	Reach	2.50	8'2"	2700	5940
		2.90	9'7"	2600	5720
		3.90	12'10"	2200	4840
320D LRR	Reach	2.50	8'2"	3100	6820
		2.90	9'7"	2900	6380
		3.90	12'10"	2400	5280
321D LCR	Reach	2.90	9'6"	2830	6250

†Working weights may vary depending on machine configuration and geographic location. Contact your Cat dealer for specific information.

Model	Boom	Stick Length		Working Weights† Buckets & Payload	
		m	ft	kg	lb
323D L	Reach	1.90	6'3"	3606	7951
		2.50	8'2"	3344	7374
		2.90	9'6"	3096	6827
	Mass	2.40	7'10"	4152	9155
	VA	1.90	6'3"	3106	6849
		2.50	8'2"	2910	6417
2.90		9'6"	2695	5942	
323D LN	Reach	1.90	6'3"	3005	6626
		2.50	8'2"	2815	6207
		2.90	9'6"	2745	6053
	VA	1.90	6'3"	2531	5581
		2.50	8'2"	2406	5305
		2.90	9'6"	2218	4891
323D L China	Reach	2.9 HD	9'6"	23 100/ 25 510	50,926/ 56,240
		2.5 HD	8'2"	23 070/ 25 490	50,860/ 56,195
	Mass	M2.4	7'9"	23 170/ 25 600	51,081/ 56,438
324D Belgium	Reach	2.50	8'2"	2910	6420
		2.95	9'8"	2690	5930
		3.60	11'10"	2320	5120
	Mass	2.00	6'7"	3390	7480
		2.50	8'2"	3030	6680
324D L Belgium	Reach	2.50	8'2"	3410	7520
		2.95	9'8"	3160	6970
		3.60	11'10"	2760	6090
	Mass	2.00	6'7"	4010	8840
		2.50	8'2"	3630	8010
	VA	2.00	6'7"	3750	8270
		2.50	8'2"	3390	7470
324D LN Belgium	Reach	2.00	6'7"	3240	7140
		2.50	8'2"	3150	6940
		2.95	9'8"	2910	6420
		3.60	11'10"	2710	5970
	Mass	2.00	6'7"	3850	8490
		2.50	8'2"	3430	7560
	VA	2.00	6'7"	3260	7190
		2.50	8'2"	2950	6500

Model	Boom	Stick Length		Working Weights† Buckets & Payload	
		m	ft	kg	lb
329D L Belgium	Reach	2.00	6'7"	3450	7610
		2.65	8'8"	3140	6930
		3.20	10'6"	2840	6270
	Mass	2.00	6'7"	4090	9020
		2.50	8'2"	3650	8050
329D L Belgium	Reach	2.00	6'7"	4060	8950
		2.65	8'8"	3680	8120
		3.20	10'6"	3360	7410
	Mass	2.00	6'7"	4810	10,610
		2.50	8'2"	4290	9460
329D L	Reach	2.00	6'7"	4090	9020
		2.50	8'2"	3740	8250
		3.20	10'6"	3360	7410
	Mass	2.00	6'7"	4090	9020
		2.50	8'2"	3650	8050
329D LN Belgium	Reach	2.00	6'7"	3530	7790
		2.65	8'8"	3210	7080
		3.20	10'6"	2910	6420
	Mass	2.00	6'7"	4180	9220
		2.50	8'2"	3730	8230
VA	2.00	6'7"	3490	7690	
	2.50	8'2"	3190	7030	
	3.20	10'6"	2870	6330	

†Working weights may vary depending on machine configuration and geographic location. Contact your Cat dealer for specific information.

†Working weights may vary depending on machine configuration and geographic location. Contact your Cat dealer for specific information.

**NOTE:** Maximum load (payload plus bucket) without quick coupler.

Model	Boom	Stick Length		Working Weights† Buckets & Payload	
		m	ft	kg	lb
<b>336D Belgium</b>	Reach	2.15	7'1"	4500	9920
		2.80	9'2"	4000	8820
		3.30	10'10"	3690	8140
		3.90	12'10"	3250	7170
	Mass	2.15	7'1"	5030	11,090
		2.55	8'4"	4440	9790
<b>336D L Belgium</b>	Reach	2.15	7'1"	4700	10,360
		2.80	9'2"	4160	9170
		3.30	10'10"	3830	8440
		3.90	12'10"	3240	7540
	Mass	2.15	7'1"	5210	11,490
		2.55	8'4"	4640	10,230
<b>336D L</b>	Reach	2.15	7'1"	4700	10,360
		2.80	9'2"	4160	9170
		3.30	10'10"	3830	8440
		3.90	12'10"	3240	7540
	Mass	2.15	7'1"	5210	11,490
		2.55	8'4"	4640	10,230
<b>336D LN Belgium</b>	Reach	2.15	7'1"	4150	9150
		2.80	9'2"	3700	8160
		3.30	10'10"	3410	7520
		3.90	12'10"	3000	6610
	Mass	2.15	7'1"	4660	10,270
		2.55	8'4"	4100	9040
		3.50	11'6"	3530	7780
<b>345B Series II - ES</b>	Reach	2.90	9'6"	8417	18,560
		3.40	11'2"	7886	17,390
Mass		2.50	8'2"	9636	21,240
		3.00	9'10"	8986	19,810
<b>345D L - FIX</b>	Long Reach	3.90	12'10"	4250	9370
		4.30	14'1"	3940	8690
	Reach	2.90	9'6"	5550	12,240
		3.35	11'0"	5180	11,420
		3.90	12'10"	4850	10,690
Mass	2.50	8'2"	6260	13,800	
	3.00	9'10"	5790	12,760	
<b>345D L - VG</b>	Long Reach	3.90	12'10"	4540	10,010
		4.30	14'1"	4880	10,760
	Reach	2.90	9'6"	6830	15,060
		3.35	11'0"	6930	15,280
		3.90	12'10"	6000	13,230
Mass	2.50	8'2"	7550	16,640	
	3.00	9'10"	6790	14,970	

†Working weights may vary depending on machine configuration and geographic location. Contact your Cat dealer for specific information.

Model	Boom	Stick Length		Working Weights† Buckets & Payload		
		m	ft	kg	lb	
<b>365C L Belgium</b>	Reach	2.84	9'3"	9965	21,970	
		3.60	11'8"	9026	19,900	
		4.15	13'6"	8262	18,220	
		4.67	15'3"	7544	16,640	
	Mass	2.57	8'4"	12 955	28,570	
		3.00	9'8"	11 956	26,360	
Mass		7 m (23'0")	2.57	8'4"	11 798	26,020
			3.00	9'8"	10 907	24,050
<b>385C Belgium</b>	Reach	4.40	14'4"	6851	15,110	
		5.50	18'0"	5917	13,050	
	General Purpose	3.40	11'1"	10 359	22,840	
		3.70	12'1"	10 018	22,090	
		4.40	14'4"	9725	21,440	
Mass		2.92	9'6"	14 209	31,330	
			3.40	11'2"	13 257	29,230
<b>385C L Belgium</b>	Reach	4.40	14'4"	7169	15,810	
		5.50	18'0"	6209	13,690	
	General Purpose	3.40	11'2"	10 755	23,720	
		3.70	12'1"	10 411	22,960	
		4.40	14'4"	10 089	22,250	
Mass		2.92	9'6"	14 309	31,550	
			3.40	11'2"	13 380	29,500

†Working weights may vary depending on machine configuration and geographic location. Contact your Cat dealer for specific information.

## Excavators

### Long Reach — Japan Sourced

- Introduction
- Range Dimensions
- Bucket Information

## INTRODUCTION

Long reach excavators are designed purposely for light duty digging that requires reach capability well above that of normal digging machines. To be able to have high enough digging forces together with an acceptable size bucket, the long reach excavators have a smaller digging envelope than the ditch cleaning machines. Long reach excavators are ideally suited for deep digging in gravel or sand pits then feeding directly into a hopper.

Caterpillar's long reach hydraulic excavators use purpose-built booms and sticks designed by Caterpillar for maximum performance and durability in light duty applications.

Long Reach Excavation Fronts include: boom, stick, linkage cylinders (boom, stick, and bucket), hydraulic lines, additional counterweight for stability over the side and heavy duty wide undercarriage. Dimensions include light excavation bucket.

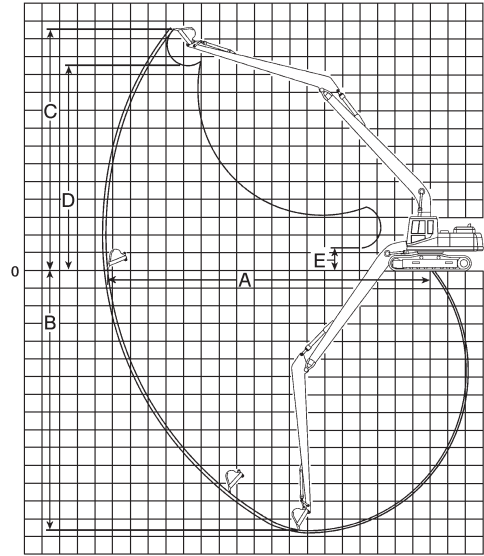

### Long Reach, Range Dimensions

#### 320D L

	m	ft
<b>A</b> Maximum Reach at Ground Level	15.73	51'7"
<b>B</b> Maximum Digging Depth	11.88	39'0"
<b>C</b> Maximum Cutting Height	13.29	43'7"
<b>D</b> Maximum Dumping Height	11.01	36'1"
<b>E</b> Minimum Loading Height	1.97	6'6"

### Long Reach, Bucket Information

Model	Bucket Type	Bucket Width		SAE Heaped Cap.		Bucket Weight		No. of Teeth	Bucket Curl Force		Stick Crowd Force	
		mm	ft	L	yd <sup>3</sup>	kg	lb		kN	lb	kN	lb
320D L	Excavation	810	2'8"	450	0.59	340	750	5	54	12,100	47	10,600

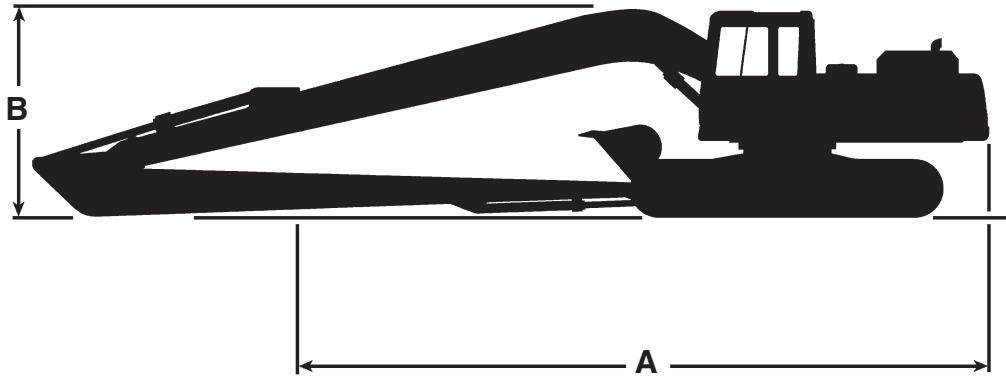

Long Reach, Shipping Dimensions	320D L	
	m	ft
<b>A</b> Overall Length (Front Folded)	12.66	41'6"
<b>B</b> Overall Height	3.21	10'6"
<b>C</b> Overall Width	3.18	10'5"

Long Reach, Component Weights	320D L	
	kg	lb
Total Component Weight Includes additional over standard	4810	10,600
Long Reach Boom	2185	4820
Long Reach Stick	1260	2780

## Excavators

### Long Reach Excavation — Belgium Sourced

- Introduction
- Range Dimensions
- Bucket Information

#### INTRODUCTION

Long Reach Excavation machines are designed specifically for jobs requiring longer reach than standard excavators, combined with digging capabilities.

The boom and the stick are purposely designed to perform digging operations with an acceptable bucket size.

The performances of the machine are attained through the use of bigger boom cylinders, heavy-duty wide undercarriage and significant additional counterweight. A heavy-duty upper-frame is also used in order to guarantee durability and resistance to the extra stresses generated by that demanding application.

Long Reach Excavation machines are ideally suited for deep or long distance digging in sand or gravel pits, slope forming, cleaning of settling banks, river conservation and other work formerly reserved for draglines.

These excavators can of course feed directly into a hopper or load a truck that would stand by their side.

The boom and the stick are designed following Caterpillar's standards, in order to provide the maximum performance and durability in digging applications.

Long Reach Excavation Fronts include: boom, stick, linkage (boom, stick, and bucket cylinders), hydraulic lines and additional counterweight.

Dimensions include the bucket.

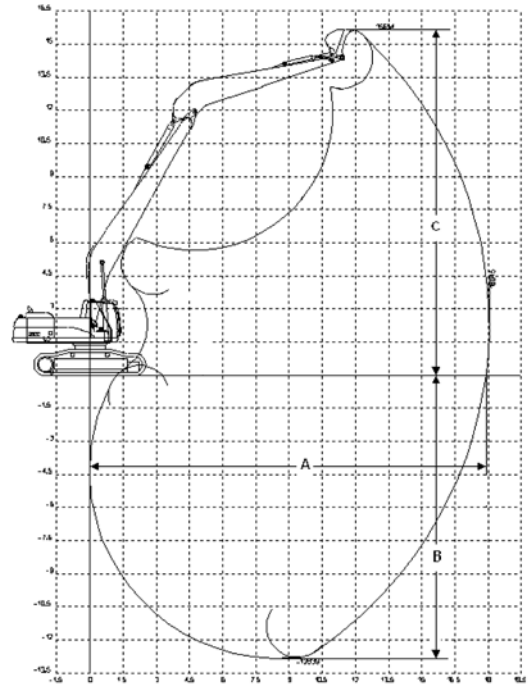

#### Long Reach Excavation, Range Dimensions

	336D LRE Long	385C LRE Long
Undercarriage	Heavy Duty Wide	Long
Boom Length	10 660 mm	12 500 mm
Stick Length	7100 mm	9500 mm
<b>A</b> Maximum Reach	18 044 mm	21 310 mm
<b>B</b> Maximum Digging Depth	12 890 mm	15 830 mm
<b>C</b> Maximum Cutting Height	15 582 mm	16 020 mm

Long Reach Excavation — Belgium Sourced  
 • Shipping Dimensions  
 • Major Component Dimensions and Weights

**Excavators**

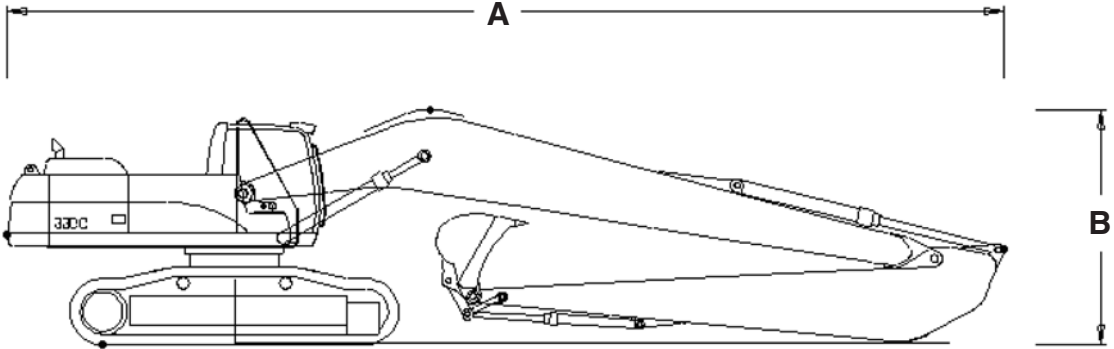

4

**Long Reach Excavation,  
Shipping Dimensions and Weight**

**336D HW  
LRE Long**

**385C L  
LRE Long**

Undercarriage	Heavy Duty Wide	Long
Shoes	700 mm	750 mm
Boom Length	10 660 mm	12 500 mm
Stick Length	7100 mm	9500 mm
<b>A</b> Overall Length (Front Folded)	15 310 mm	18 780 mm
<b>B</b> Overall Height (Front Folded)	3594 mm	4280 mm
Overall Width	3620 mm	3500 mm
Operating Weight	39 676 kg	88 490 kg



**Long Reach Excavation Lift Capacities at Ground Level**

Lift Capacities at Ground Level		3 m		4.5 m		6 m		7.5 m		9 m	
		Front Load	Side Load	Front Load	Side Load	Front Load	Side Load	Front Load	Side Load	Front Load	Side Load
<b>336D L LRE Long</b>	<b>kg</b>	2250*	2250*	4850*	4850*	9940*	8610	7490*	6340	5940*	4880
<b>385C L LRE Long</b>	<b>kg</b>	5480*	5480*	9290*	9290*	16 720*	16 720*	18 040*	17 340	14 370*	13 490

Lift Capacities at Ground Level		10.5 m		12 m		13.5 m		15 m		16.5 m	
		Front Load	Side Load	Front Load	Side Load	Front Load	Side Load	Front Load	Side Load	Front Load	Side Load
<b>336D L LRE Long</b>	<b>kg</b>	4890*	3860	4040*	3080	3570*	2480	3120*	2000	2590*	1560
<b>385C L LRE Long</b>	<b>kg</b>	11 840*	10 800	10 000*	8780	8600*	7210	7500*	5950	6600*	4910

Lift Capacities at Ground Level		18 m		19.5 m		Max. Reach		Maximum Reach Radius
		Front Load	Side Load	Front Load	Side Load	Front Load	Side Load	
<b>336D L LRE Long</b>	<b>kg</b>	—	—	—	—	1940*	1410	17.62 m
<b>385C L LRE Long</b>	<b>kg</b>	5840*	4050	4340*	3320	3250*	2900	20.77 m

\*Load limited by hydraulic capacity rather than tipping.

- Introduction
- Range Dimensions
- Bucket Information

**INTRODUCTION**

Super long reach excavators are designed specifically for those jobs requiring maximum reach well beyond the range of normal excavators. Those machines are designed to drag a small bucket at about 90 degrees over the side of the tracks towards the excavator; they are not suited for digging work. Caterpillar offers the Long Reach excavators for light digging applications with a much larger digging envelope than normal excavators. Super long reach excavators are suited for ditch cleaning, slope finishing, river conservation and other work formerly reserved to draglines.

Caterpillar's super long reach hydraulic excavators use purpose-built booms and sticks designed by Caterpillar for maximum performance and durability in dragging applications.

Super long reach fronts include: boom, stick, linkage cylinders (boom, stick, and bucket), hydraulic lines and additional counterweight for stability while working over the side. Dimensions include bucket.

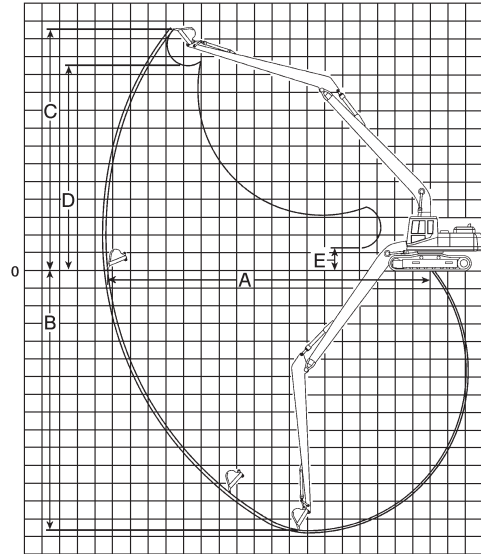

Super Long Reach, Range Dimensions	312C L*		315C L, 317B L*		320D L	
	m	ft	m	ft	m	ft
<b>A</b> Maximum Reach at Ground Level	12.54	41'2"	13.00	42'8"	15.60	51'2"
<b>B</b> Maximum Digging Depth	9.80	32'2"	10.10	33'2"	11.75	38'7"
<b>C</b> Maximum Cutting Height	10.96	35'11"	11.64	38'2"	13.24	43'5"
<b>D</b> Maximum Dumping Height	9.01	29'9"	9.58	31'5"	11.14	36'7"
<b>E</b> Minimum Loading Height	2.15	7'1"	2.55	8'4"	2.10	6'10"

	324D L		329D L	
	m	ft	m	ft
<b>A</b> Maximum Reach at Ground Level	18.60	61'0"	18.60	61'0"
<b>B</b> Maximum Digging Depth	14.60	47'11"	14.60	48'0"
<b>C</b> Maximum Cutting Height	15.40	50'7"	14.80	48'8"
<b>D</b> Maximum Dumping Height	13.30	43'7"	12.70	41'9"
<b>E</b> Minimum Loading Height	1.50	4'10"	1.50	4'10"

**Super Long Reach, Bucket Information**

Model	Bucket Type	Bucket Width		SAE Heaped Cap.		Bucket Weight		No. of Teeth	Bucket Curl Force		Stick Crowd Force	
		mm	ft	L	yd <sup>3</sup>	kg	lb		kN	lb	kN	lb
312C*	Ditch Cleaning	920	3'0"	480	0.63	230	510	4	44	9900	37	8300
320C L	Ditch Cleaning	1140	3'9"	600	0.78	290	640	0	60	13,500	46	10,300
320D L	Ditch Cleaning	1140	3'9"	600	0.78	290	640	0	60	13,500	46	10,300
324D L	Ditch Cleaning	1140	3'9"	600	0.78	290	640	0	61	13,700	51	11,500
329D L*	Ditch Cleaning	1140	3'9"	600	0.78	290	640	5	61	13,700	51	11,500

\*Custom product.

## Excavators

### Super Long Reach — Japan/U.S. Sourced

- Shipping Dimensions
- Major Component Weights

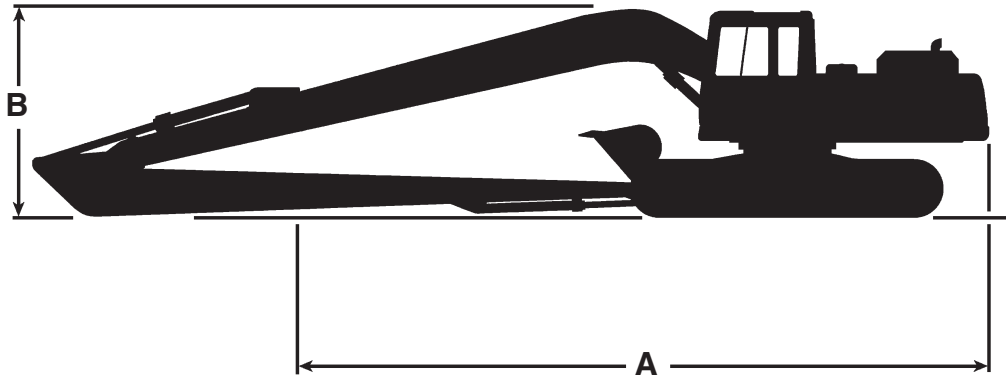

Super Long Reach, Shipping Dimensions	312C*		315D L*		320D L	
	m	ft	m	ft	m	ft
<b>A</b> Overall Length (Front Folded)	10.22	33'6"	11.23	36'10"	12.66	41'6"
<b>B</b> Overall Height	2.80	9'2"	2.92	9'7"	3.21	10'6"
<b>C</b> Overall Width	2.76	9'1"	2.75	9'0"	3.18	10'5"

	324D L		329D L	
	m	ft	m	ft
<b>A</b> Overall Length (Front Folded)	14.30	47'1"	14.40	47'2"
<b>B</b> Overall Height	3.15	10'4"	3.23	10'7"
<b>C</b> Overall Width	3.40	11'1"	3.39	11'1"

Super Long Reach, Component Weights	312C*		315D L*		320D L	
	kg	lb	kg	lb	kg	lb
Total Component Weight Includes additional over standard	2450	5400	3050	6725	4840	10,670
Long Reach Boom	1140	2510	1210	2670	2185	4820
Long Reach Stick	640	1410	780	1720	1260	2780

	324D L		329D L	
	kg	lb	kg	lb
Total Component Weight Includes additional over standard	6950	15,320	6500	14,330
Long Reach Boom	3580	7893	3730	8223
Long Reach Stick	1610	3549	1610	3549

\*Custom product.

- Short Reach
- Range Dimensions
- Front Attachment Information

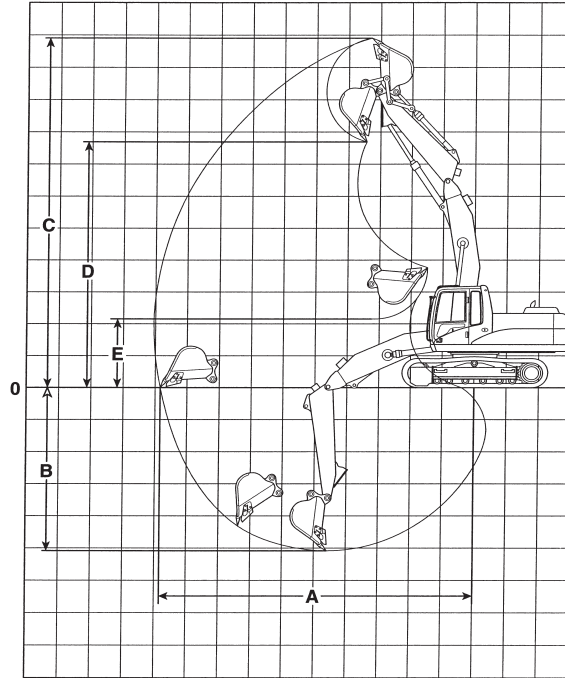

**Short Reach, Range Dimensions**

	314C CR*		336D L*	
	m	ft	m	ft
<b>A</b> Maximum Reach at Ground Level	6.54	21'5"	8.88	29'2"
<b>B</b> Maximum Digging Depth	8.15	26'9"	9.95	32'8"
<b>C</b> Maximum Cutting Height	2.22	7'3"	3.76	12'4"
<b>D</b> Maximum Dumping Height	5.56	18'3"	6.64	21'9"
<b>E</b> Minimum Loading Height	1.91	6'3"	1.80	5'11"

**Short Reach, Front Attachment Information**

Model	Boom Length		Stick Length		Heaped Capacity	
	mm	ft	mm	ft	L	yd <sup>3</sup>
314C CR*	3200	10'6"	2400	7'10"	500	0.7
336D L*	4350	14'3"	3200	10'6"	1400	1.83

\*Custom product.

## Excavators

### Short Reach

- Shipping Dimensions
- Major Component Weights

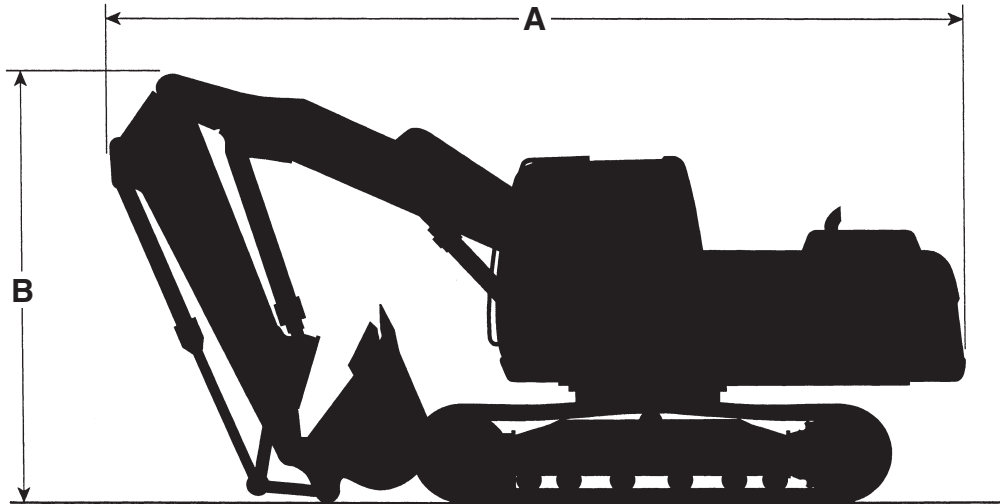

### Short Reach, Shipping Dimensions

	314C CR*		336D L*	
	m	ft	m	ft
<b>A</b> Overall Length (Front Folded)	5.35	17'7"	8.27	27'2"
<b>B</b> Overall Height	2.73	8'11"	3.87	12'8"
<b>C</b> Overall Width	2.49	8'2"	3.35	11'0"

### Short Reach, Component Weights

	314C CR*		336D L*	
	kg	lb	kg	lb
Total Component Weight				
Includes additional over standard	3350	7390	6000	13,230
Short Reach Boom	1140	2510	2170	4780
Short Reach Stick	600	1320	1300	2870

\*Custom product.

Telescopic Stick  
 ● Range Dimensions  
 ● Front Attachment Information  
 (Japan Sourced)

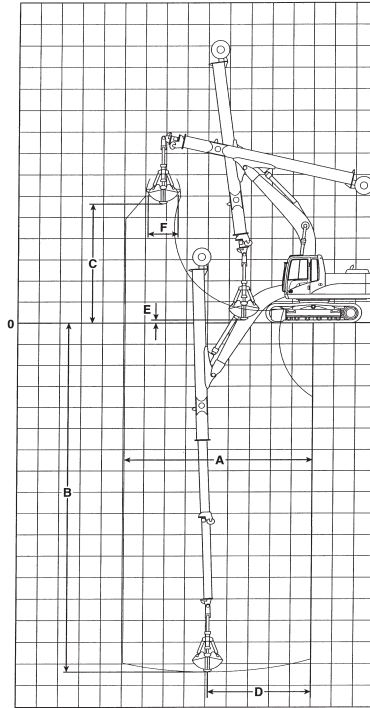

Telescopic Stick, Range Dimensions	320C L*		322C L*		329D L*		336D L*	
	m	ft	m	ft	m	ft	m	ft
<b>A</b> Maximum Operating Radius	9.50	31'2"	9.50	31'2"	9.50	31'2"	9.50	31'2"
<b>B</b> Maximum Digging Depth	20.89	68'6"	20.55	67'5"	20.89	68'6"	25.69	84'3"
<b>C</b> Maximum Dumping Height	5.29	17'4"	5.20	17'1"	5.29	17'4"	5.66	18'7"
<b>D</b> Reach at Maximum Digging Depth	4.57	15'0"	4.51	14'10"	4.57	15'0"	4.76	15'7"
<b>E</b> Reach at Maximum Dumping Height	7.09	23'3"	6.43	21'1"	7.09	23'3"	7.24	23'9"
<b>F</b> Bucket Width	5.70	18'8"	5.90	19'4"	6.15	20'2"	6.50	21'4"

**Telescopic Stick, Front Attachment Information**

Model	Boom Length		Heaped Capacity	
	mm	ft	L	yd <sup>3</sup>
320C L*	5700	18'8"	430	0.6
322C L*	5900	19'4"	520	0.7
329D L*	6150	20'2"	700	0.9
336D L*	6500	21'4"	1000	1.3

\*Custom product.

## Excavators

### Telescopic Stick

- Shipping Dimensions
- Major Component Weights

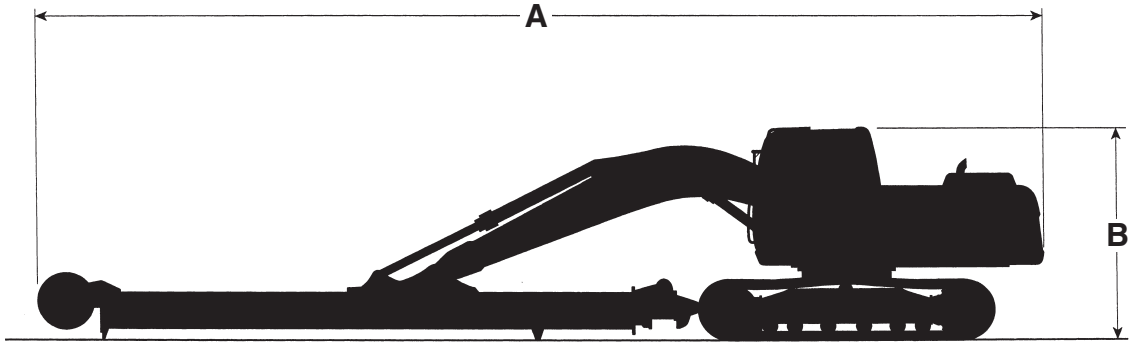

Telescopic Stick, Shipping Dimensions	320C L*		322C L*		329D L*		336D L*	
	m	ft	m	ft	m	ft	m	ft
<b>A</b> Overall Length (Front Folded)	13.96	45'10"	14.39	47'3"	14.58	47'10"	10.13	33'3"
<b>B</b> Overall Height	2.93	9'7"	2.98	9'9"	3.09	10'2"	3.35	11'0"
<b>C</b> Overall Width	3.18	10'5"	3.39	11'1"	3.39	11'1"	3.34	10'11"

Telescopic Stick, Component Weights	320C L*		322C L*		329D L*		336D L*	
	kg	lb	kg	lb	kg	lb	kg	lb
Total Component Weight Includes additional over standard	1040	2290	1180	2600	6500	14,330	6000	13,230
Rated Boom	2050	4520	2480	5470	2750	6060	3830	8440
Telescopic Stick	3100	6830	3170	6990	3110	6860	5540	12,210
Telescopic Bucket	940	2070	1120	2470	1360	3000	1620	3570

\*Custom product.

## Features

The ultra-high demolition (UHD) machines, 325D UHD, 330D UHD, 345C UHD, 365C UHD and 385C UHD are all equipped with the following features:

- **Integrated Tiltable Cab.** The large C Series and core D Series tilt cabs are integrated into the upper-frame. The tilting mechanism of the cab is completely protected against debris, scrap, etc. The main advantage of this is that it does not increase the shipping height compared to the standard cab.
- **Boom Hook System.** The front parts are equipped with a reliable and safe hook system between the boom foot and boom nose. Compared to the traditional pin-mounted joint, the hook system significantly reduces the time needed to change between the Ultra-High front parts and the short retrofit configuration, or the long-reach excavation configuration. In principle, the boom hook system consists of a hook system to pick up the front parts and a mechanical expander pin to secure these front parts onto the boom foot. The absence of any hydraulic parts, as well as a full-length heavy-duty one-piece securing pin, ensures a safe and reliable operation.
- **Hydraulic Quick Disconnects or face-to-face ball valves (new generation).** The hydraulic lines between boom foot and boom nose are fitted with hydraulic quick disconnects or Ball Valves (new generation) to even further reduce the time needed to change the front parts. Oil spillage and contamination is reduced through the flat-face design.
- **Dedicated Ultra-High Demolition Linkage.** Because Ultra-High Demolition applications require a different working envelope than standard applications, a purpose-designed linkage is standard on the Ultra-High Demolition front parts.  
Besides providing an optimized working envelope, this linkage also greatly improves controllability in nearly every position.



# Excavators

## Ultra-High Demolition Arrangements — Belgium Sourced

- 325D L UHD Shipping Dimensions
- 325D L UHD Range Dimensions

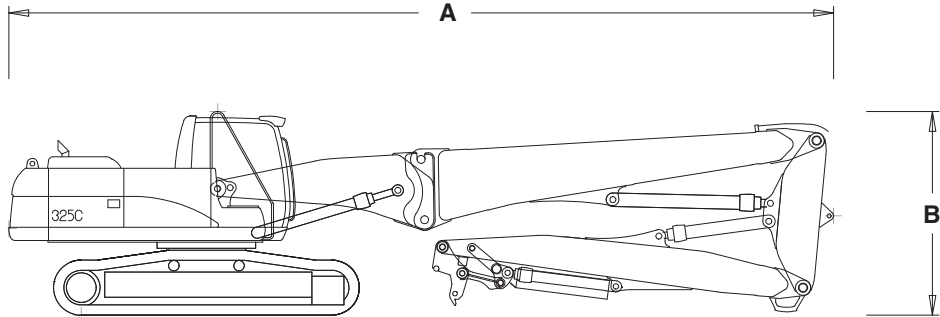

### 325D L with UHD Front Parts

<b>A</b> Shipping Length	12 500 mm
<b>B</b> Shipping Height	2920 mm
Operating Weight	36 200 kg

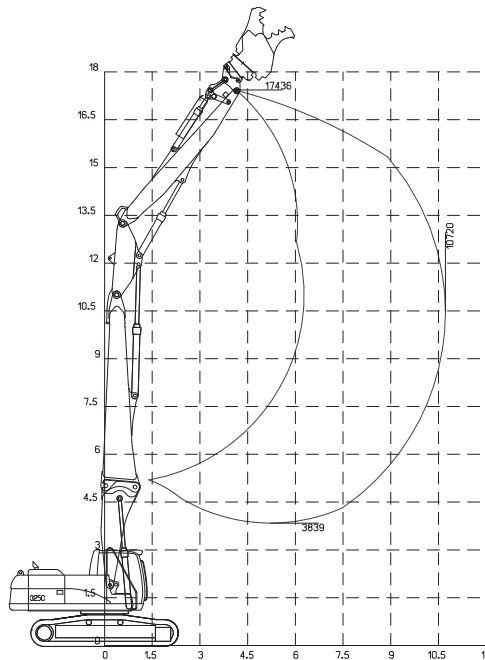

### 325D L with UHD Front Parts — Reaches

Maximum Allowable Angle from Vertical	20°
Maximum Pin Height	17 310 mm
Maximum Horizontal Reach	10 730 mm
Maximum Tool Weight Over the Front*	3000 kg
Operating Weight	36 200 kg

\*Tool weight includes mounting bracket and quick coupler.

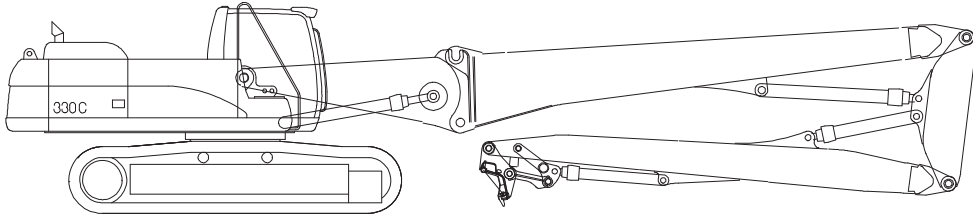

330D L with UHD Front Parts	Undercarriages				
	L	LN	Hydraulic Variable Gauge	Heavy Duty High Wide	345C L
Shoes	700 mm	600 mm	700 mm	700 mm	600 mm
Shipping Length	14 830 mm	14 830 mm	14 830 mm	14 830 mm	14 830 mm
Shipping Height	3100 mm	3100 mm	3100 mm	3100 mm	3100 mm
Shipping Width	3290 mm	2990 mm	3100 mm	3620 mm	2990 mm
Operating Weight	42 360 kg	41 910 kg	47 870 kg	43 930 kg	46 940 kg

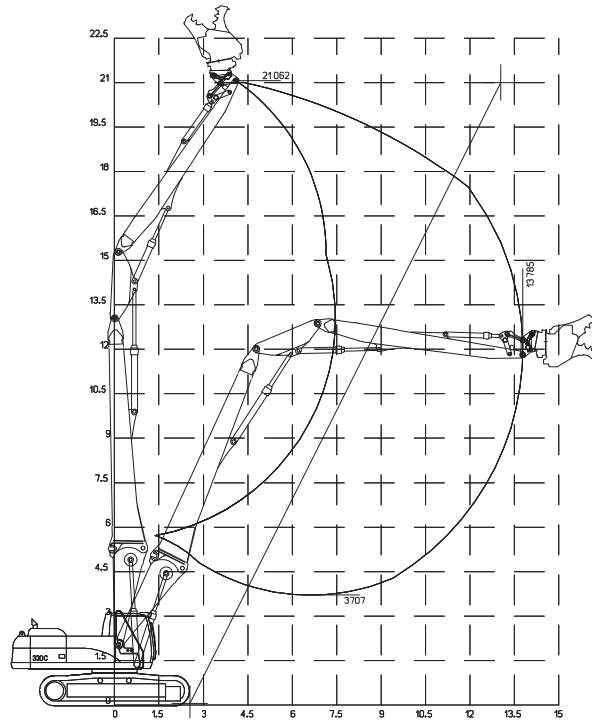

<b>330D L with UHD Front Parts — Reaches</b>	<b>330D L UHD</b>	<b>330D LN UHD</b>	<b>330D L HVG UHD</b>	<b>330D L HDHW UHD</b>	<b>330D UHD with 345C L chassis</b>
Maximum Allowable Angle from Vertical	25°	25°	25°	25°	25°
Maximum Horizontal Reach	13 850 mm	13 850 mm	13 850 mm	13 850 mm	13 850 mm
Maximum Vertical Pin Height	21 060 mm	21 060 mm	21 120 mm	21 290 mm	21 270 mm
Maximum Tool Weight Over the Front*	3000 kg	3000 kg	3000 kg	3000 kg	3000 kg
Maximum Tool Weight Over the Side*	1800 kg	—	2700 kg	2450 kg	2700 kg

\*Tool weight includes mounting bracket and quick coupler.

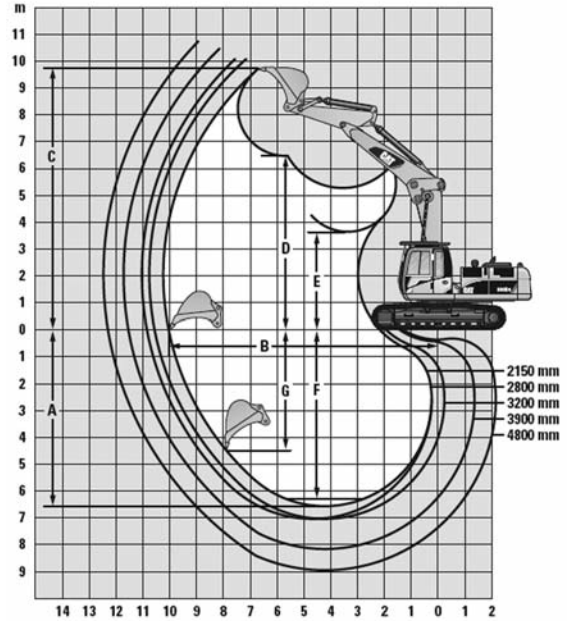
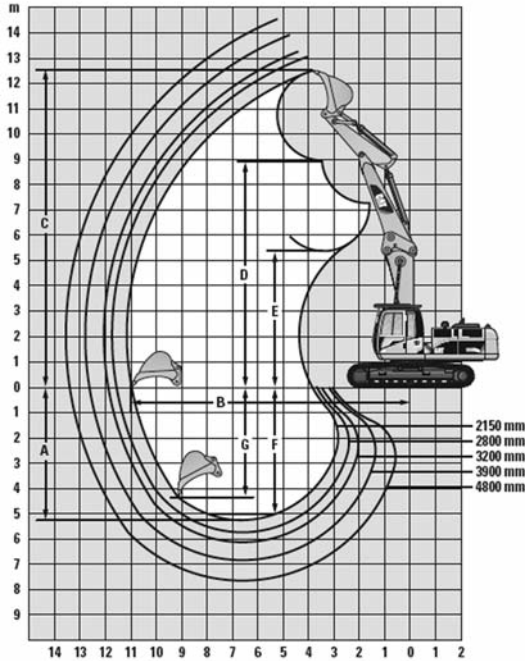

330D L HVG UHD Retrofit — Straight Position	Stick Length			
	2150 mm	2800 mm	3200 mm	3900 mm
<b>A</b> Maximum Digging Depth	-4465 mm	-4979 mm	-5379 mm	-6079 mm
<b>B</b> Maximum Reach at Ground Level	11 298 mm	11 870 mm	12 209 mm	12 933 mm
<b>C</b> Maximum Cutting Height	12 778 mm	13 359 mm	13 562 mm	14 219 mm
<b>D</b> Maximum Loading Height	9016 mm	9838 mm	10 043 mm	10 698 mm
<b>E</b> Minimum Loading Height	5454 mm	4989 mm	4474 mm	3844 mm

330D L HVG UHD Retrofit — Bent Position	Stick Length			
	2150 mm	2800 mm	3200 mm	3900 mm
<b>A</b> Maximum Digging Depth	-6029 mm	-6542 mm	-6942 mm	-7642 mm
<b>B</b> Maximum Reach at Ground Level	10 374 mm	10 949 mm	11 239 mm	11 951 mm
<b>C</b> Maximum Cutting Height	9939 mm	10 508 mm	10 431 mm	10 886 mm
<b>D</b> Maximum Loading Height	6626 mm	7257 mm	7243 mm	7655 mm
<b>E</b> Minimum Loading Height	3770 mm	3256 mm	2856 mm	2156 mm

330D L HVG LRE Retrofit — Straight Position	Length	330D L HVG LRE Retrofit — Bent Position	Length
	17 585 mm		16 695 mm
<b>A</b> Maximum Digging Depth	-11 080 mm	<b>A</b> Maximum Digging Depth	-12 745 mm
<b>B</b> Maximum Reach at Ground Level	17 585 mm	<b>B</b> Maximum Reach at Ground Level	16 695 mm
<b>C</b> Maximum Cutting Height	15 685 mm	<b>C</b> Maximum Cutting Height	11 350 mm

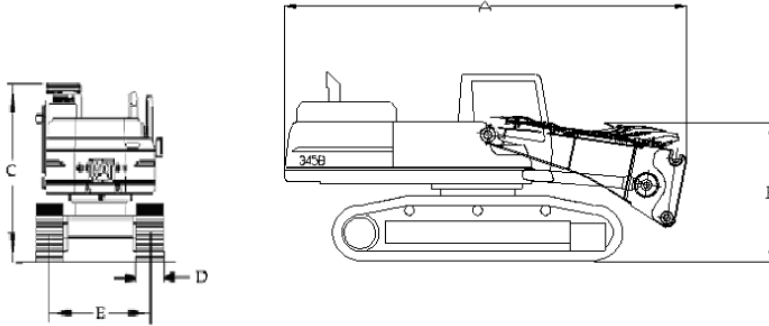

345C L UHD Base Machine	Undercarriages	
	L	Hydraulic Variable Gauge
Shoes	600 mm	600 mm
Length	7810 mm	7810 mm
Height with Overhead Guard*	3740 mm	3720 mm
Working Width	3490 mm	3611 mm
Shipping Width	2990 mm	3000 mm
Operating Weight	47 320 kg	53 280 kg

\*Hydraulic lines are included.

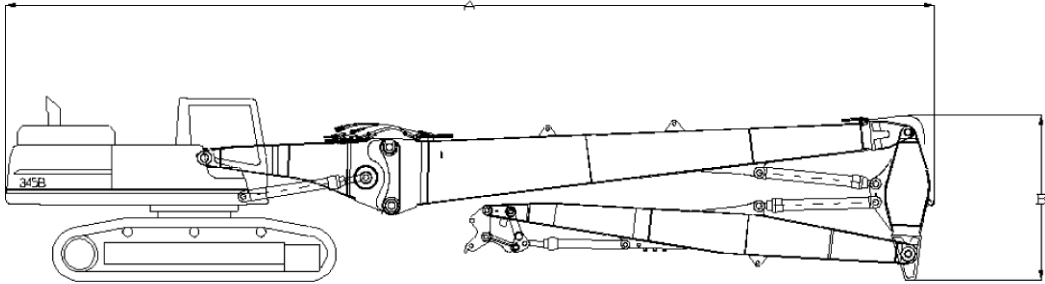

345C L with UHD Front Parts	UHD 26M, Undercarriages		UHD 28M, Undercarriages	
	L	Hydraulic Variable Gauge	L	Hydraulic Variable Gauge
Shoes	600 mm	600 mm	600 mm	600 mm
Shipping Length	17 800 mm	17 800 mm	17 800 mm	17 800 mm
Shipping Height	3740 mm	3720 mm	3740 mm	3720 mm
Shipping Width	2990 mm	3000 mm	2990 mm	3000 mm
Operating Weight	57 900 kg	63 800 kg	58 200 kg	64 200 kg

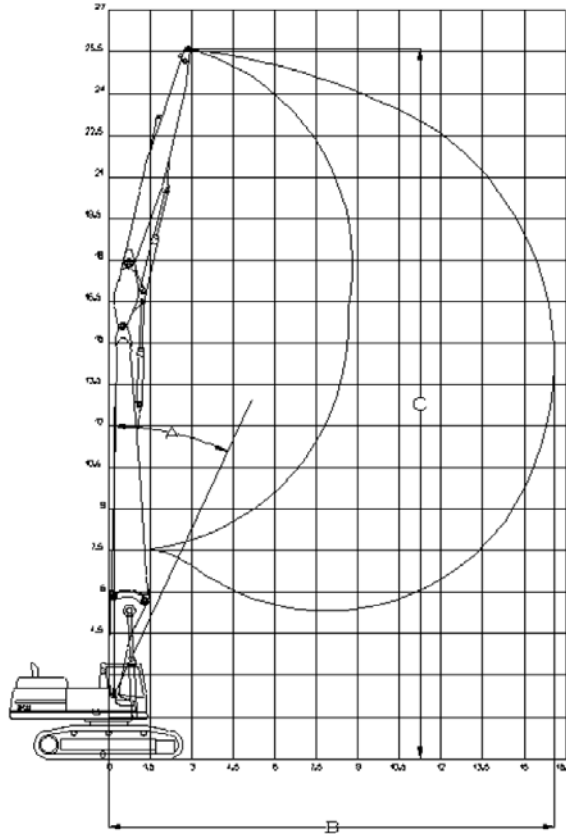

<b>345C L with UHD Front Parts — Reaches</b>	<b>345C L UHD 26M</b>	<b>345C L HVG UHD 26M</b>	<b>345C L UHD 28M</b>	<b>345C L HVG UHD 28M</b>
Maximum Allowable Angle from Vertical	25°	25°	25°	25°
Maximum Horizontal Reach	16 400 mm	16 400 mm	18 150 mm	18 150 mm
Maximum Vertical Pin Height	26 100 mm	26 100 mm	27 900 mm	27 900 mm
Maximum Tool Weight Over the Front*	3300 kg	3300 kg	2500 kg	2500 kg
Maximum Tool Weight Over the Side*	2500 kg	3000 kg	2000 kg	2500 kg

\*Tool weight includes mounting bracket and quick coupler.

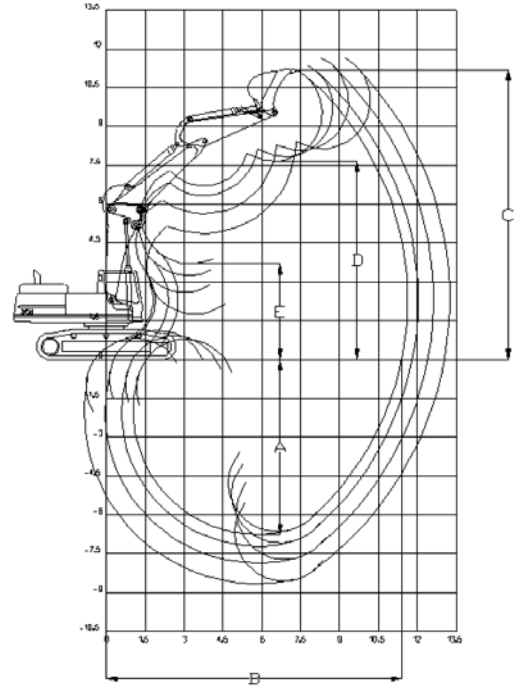
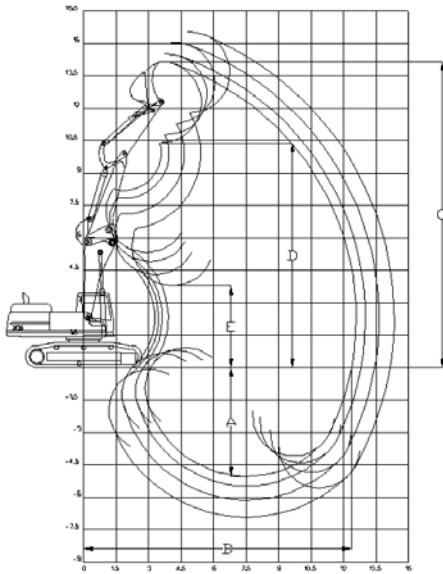

345C L UHD Retrofit — Straight Position	Stick Length	
	R2.9T	R3.4T
A Maximum Digging Depth	-4895 mm	-5345 mm
B Maximum Reach at Ground Level	12 368 mm	12 804 mm
C Maximum Cutting Height	13 712 mm	14 038 mm
D Maximum Loading Height	9977 mm	10 303 mm
E Minimum Loading Height	5055 mm	4618 mm

345C L UHD Retrofit — Bent Position	Stick Length	
	R2.9T	R3.4T
A Maximum Digging Depth	-6350 mm	-6800 mm
B Maximum Reach at Ground Level	11 465 mm	11 878 mm
C Maximum Cutting Height	10 770 mm	10 921 mm
D Maximum Loading Height	7418 mm	7569 mm
E Minimum Loading Height	3544 mm	3095 mm



# Excavators

## Ultra-High Demolition Arrangements — Belgium Sourced

- 365C L UHD Shipping Dimensions
- 365C L UHD Range Dimensions

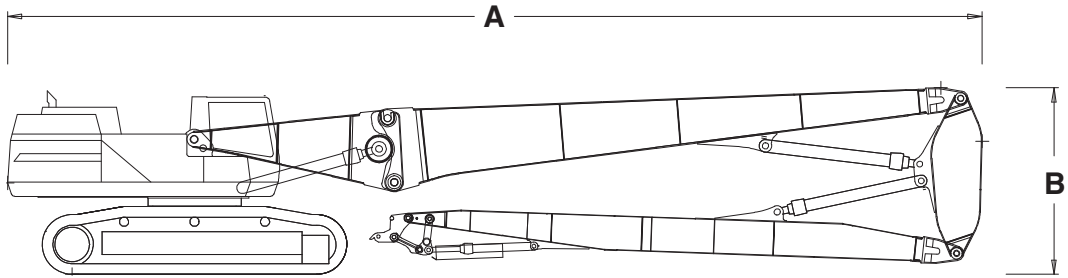

### 365C L with UHD Front Parts

### With 385C L Undercarriage

<b>A</b> Storage Length	20 720 mm
<b>B</b> Boom Height	4320 mm
Operating Weight	85 690 kg

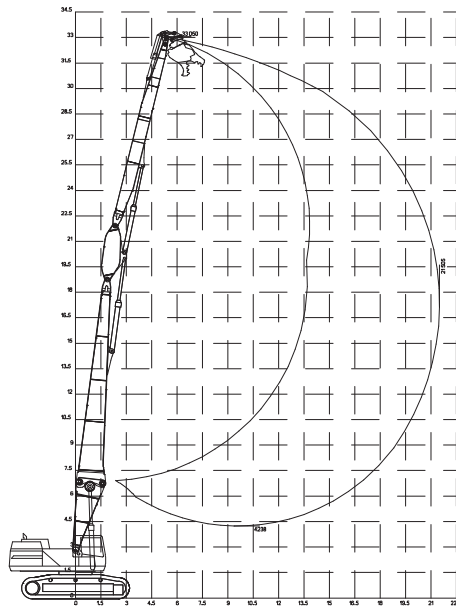

### 365C L with UHD Front Parts — Reaches

### With 385C L Undercarriage

Maximum Allowable Angle from Vertical	25°
Maximum Pin Height	33 100 mm
Maximum Horizontal Reach	21 600 mm
Maximum Tool Weight Over the Front*	3000 kg
Operating Weight	85 690 kg

\*Tool weight includes mounting bracket and quick coupler.

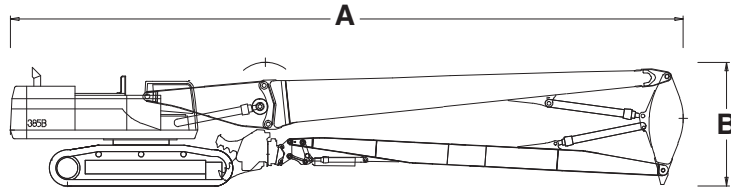

385C L with UHD Front Parts	40 m version
<b>A</b> Storage Length	22 710 mm
<b>B</b> Boom Height	8120 mm
Operating Weight	98 720 kg

\*With front parts extended (boom foot + LRD boom nose + stick).

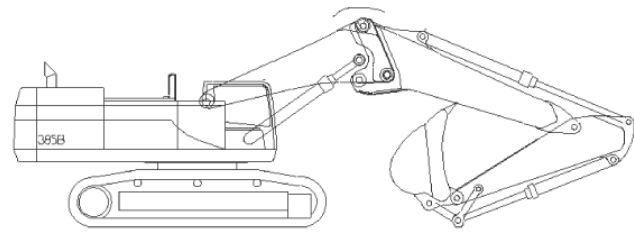

385C L with Retrofit Front Parts — Straight Position	R3.4JB	R3.7HB	R4.4HB	R5.5HB
Shipping Length	4950 mm	4930 mm	5230 mm	5995 mm
Shipping Height	16 295 mm	16 220 mm	16 125 mm	15 860 mm
Operating Weight	94 885 kg	92 955 kg	93 180 kg	93 240 kg

385C L with Retrofit Front Parts — Bent Position	R3.4JB	R3.7HB	R4.4HB	R5.5HB
Shipping Length	5465 mm	5340 mm	5565 mm	6005 mm
Shipping Height	15 490 mm	15 475 mm	15 490 mm	15 400 mm
Operating Weight	94 885 kg	93 725 kg	93 730 kg	93 490 kg

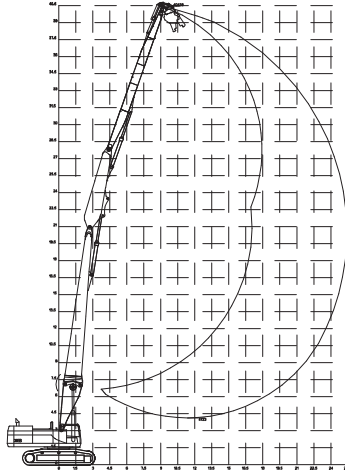

**385C L with UHD Front Parts — Reaches**

**40 m version**

Maximum Allowable Angle from Vertical	15°
Maximum Pin Height	39 500 mm
Maximum Horizontal Reach	25 200 mm
Maximum Tool Weight Over the Front*	2100 kg
Operating Weight	98 720 kg

\*Maximum authorized tool weight over the front only; includes a dedicated quick coupler.

**385C L UHD Retrofit — Straight Position**

**Stick Length**

	<b>R3.4JB</b>	<b>R3.7HB</b>	<b>R4.4HB</b>	<b>R5.5HB</b>
Maximum Digging Depth	-4570 mm	-4725 mm	-5425 mm	-6525 mm
Maximum Reach	15 525 mm	15 595 mm	16 285 mm	17 365 mm
Maximum Cutting Height	17 620 mm	17 405 mm	17 970 mm	18 825 mm

**385C L UHD Retrofit — Bent Position**

**Stick Length**

	<b>R3.4JB</b>	<b>R3.7HB</b>	<b>R4.4HB</b>	<b>R5.5HB</b>
Maximum Digging Depth	-7040 mm	-7195 mm	-7895 mm	-8995 mm
Maximum Reach at Ground Level	14 480 mm	14 475 mm	15 140 mm	16 175 mm
Maximum Cutting Height	13 860 mm	13 195 mm	13 495 mm	13 890 mm

- Straight Boom
- Shipping Dimensions

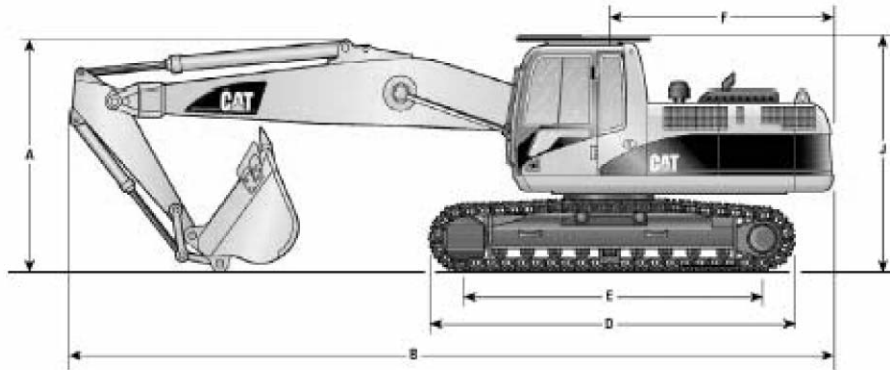

Model	325D L/LN		330D L/LN	
	stick	mm	stick	mm
<b>A</b> Shipping Height*	R2.0DB R2.65CB2 R3.2CB2	3170 3170 3170	R2.15TB R2.8DB R3.2DB R3.9DB	3280 3280 3280 3770
<b>B</b> Shipping Length*	R2.0DB R2.65CB2 R3.2CB2	10 835 10 625 10 615	R2.15TB R2.8DB R3.2DB R3.9DB	11 915 11 505 11 500 11 365
<b>C</b> Shipping Width				
L		3390		3290
LN		2990		2990

\*With stick cylinder fully extended. For some configurations, retracting the stick cylinder will result in a lower shipping height but increased shipping length.

# Excavators

## Demolition Arrangements — Belgium Sourced

- Straight Booms
- Range Dimensions

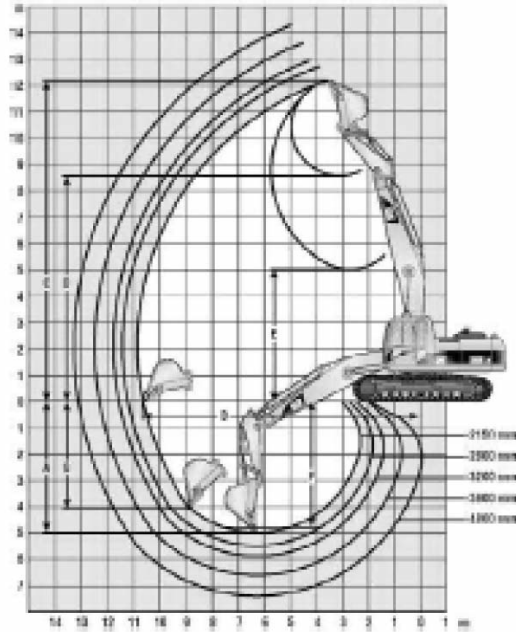

### 325D L

Stick		R2.0D	R2.65C	R3.2C
<b>A</b> Maximum Digging Depth	mm	-4720	-5225	-5775
Maximum Reach at Ground Level	mm	10 095	10 640	11 145
Maximum Cutting Height	mm	11 540	12 050	12 435
Maximum Loading Height	mm	8020	8815	9195
Minimum Loading Height	mm	4725	4200	3600
Operating Weight	kg	29 930	29 250	29 390

### 330D L

Stick		R2.15E	R2.8D	R3.2D	R3.9D
<b>A</b> Maximum Digging Depth	mm	-5040	-5550	-5950	-6650
Maximum Reach at Ground Level	mm	10 715	11 285	11 635	12 365
Maximum Cutting Height	mm	12 315	12 890	13 120	13 790
Maximum Loading Height	mm	8535	9380	9600	10 275
Minimum Loading Height	mm	4955	4505	3975	3370
Operating Weight	kg	35 660	35 090	35 160	35 310

- Tracks vs. Wheels
- Stick/Bucket Combinations

## MACHINE SELECTION: TRACKS VERSUS WHEELS

### Features:

#### Tracks

- Flotation
- Traction
- Maneuverability
- Severe underfoot
- Faster machine repositioning

#### Wheels

- Mobility and speed
- No pavement damage
- Better stability with outriggers or dozers
- Leveling machine with outriggers
- Dozing capability

### 307–385

Unless the application calls for a lot of travel to, from, and around the job sites, a track-type excavator could be the better choice. Track-type excavators provide good traction and flotation in almost all kinds of underfoot conditions. Consistently good drawbar power provides excellent maneuverability. The tracked undercarriage also provides good overall stability. If the job calls for frequent machine repositioning, a track-type excavator will provide better operating efficiency — where raising and lowering outriggers would take extra time.

### Wheels (M313D–M322D)

Looking for a highly versatile machine? A machine that can do more than mass excavation and trenching. Consider a Wheel Excavator.

A Wheel Excavator combines traditional excavator features such as 360° swing, long reach, deep digging depth, high loading height, high digging forces and high lift capacities, with the mobility of

a wheeled undercarriage. The rubber tires allow the excavator to travel paved roads, work in shopping malls, squares, parking lots and other paved areas without damaging the pavement. It's mobility allows fast independent travel between jobsites as well as on the jobsite giving you more job planning flexibility. The Wheel Excavator is the ideal tool for truck loading in tight quarters, undercutting concrete or asphalt, patching, shoulder work, curb and gutter repair, landscaping, spreading top soil, fine grading, laying pipe, placing manholes or ditch cleaning.

A Wheel Excavator is also an ideal machine in material handling. It can load or unload trucks and carry loads around the job site. Stabilizers and a dozer blade can be pinned to the undercarriage increasing the machines stability during lifting.

Equip the Wheel Excavator with dedicated special attachments such as cab riser, material handling stick and boom. Add the additional hydraulic circuit option and your ready for a complete range of special tools. Ditch cleaning bucket, clamshell, grapples, hammers to name a few.

Cat Wheel Excavators offer a load independent, load-sensing, flow distribution hydraulic system that gives the operator absolute precision and control no matter what the application.

Machine weight is the key to selecting a Wheel Excavator. Following are some additional factors that need to be considered.

Choose the proper boom and stick for your reach, digging depth and lifting requirements. Stability can be greatly enhanced by adding outriggers and/or a dozer blade. Additional hydraulic circuits can be added depending on your application and stick end attachments.

### Acceptable Bucket/Stick Combinations

The following charts identify the acceptable bucket and stick combinations for Cat Wheel Excavators and are based on stability. Minimum stability occurs with the linkage oriented over the side and positioned as shown in the visual. Dozer and/or stabilizers (if equipped) are raised and the bucket contains a full load. The longest stick is shown that has acceptable stability for each bucket. That stability is 1.1 moment ratio or better. Once this stability factor is established, all shorter sticks are then acceptable with the listed bucket.

**EXCAVATOR SHOE SELECTION**

Undercarriage life can be extended by equipping the machine properly for the application.

Many excavators work on pavement or flat, soft ground and experience few undercarriage problems. But if those same machines (usually equipped with wide track pads) were placed in severe underfoot conditions, undercarriage destruction could occur very rapidly.

The rule, used for other track-type machines — “Whenever possible use the narrowest shoes available” — is even more valid for excavators.

The best general purpose track shoe is the triple grouser. It has a good section modulus and offers the best compromise between traction and minimum disturbance to paved surface.

The double grouser shoe has a better section modulus and is more aggressive than the triple grouser section. Single grouser shoes are offered for maximum traction. Some users like single grousers for added mobility in hilly terrain.

The following table lists ground pressures for various width shoes (reach boom, medium stick and bucket):

Model	Shoe Type	Shoe Width		Pressure	
		mm	in	kPa	psi
<b>301.6C</b>	Steel Double Grouser	230	<b>9</b>	28.2	<b>4.09</b>
	Rubber Belt	230	<b>9</b>	27.2	<b>3.94</b>
<b>301.8C</b>	Steel Double Grouser	230	<b>9</b>	28.8	<b>4.17</b>
	Rubber Belt	230	<b>9</b>	27.7	<b>4.01</b>
<b>302.5C</b>	Steel Double Grouser	300	<b>12</b>	26.6	<b>3.85</b>
	Rubber Belt	300	<b>12</b>	25.6	<b>3.71</b>
<b>303C CR</b>	Steel Double Grouser	300	<b>12</b>	30.9	<b>4.48</b>
	Rubber Belt	300	<b>12</b>	29.9	<b>4.33</b>
<b>304C CR</b>	Steel Double Grouser	400	<b>15</b>	28.5	<b>4.13</b>
	Rubber Belt	400	<b>15</b>	25.0	<b>3.63</b>
<b>305C CR</b>	Steel Double Grouser	400	<b>16</b>	28.5	<b>4.10</b>
	Rubber	400	<b>16</b>	27.9	<b>4.05</b>
<b>305.5*</b>	Steel Double Grouser	400	<b>16</b>	33.4	<b>4.84</b>
	Rubber Belt	400	<b>16</b>	32.4	<b>4.70</b>
<b>307C**</b>	Triple	450	<b>18</b>	30.0	<b>4.35</b>
	Triple	600	<b>24</b>	23.0	<b>3.34</b>
	Segmented Rubber	450	<b>18</b>	31.0	<b>4.50</b>
<b>307D</b>	Steel Triple Grouser	450	<b>18</b>	33.1	<b>4.80</b>
	Steel Triple Grouser	600	<b>24</b>	25.0	<b>3.60</b>
	Segmented Rubber	450	<b>18</b>	34.0	<b>4.90</b>
<b>308D CR SB</b>	Steel Triple Grouser	450	<b>18</b>	36.8	<b>5.30</b>
	Steel Triple Grouser	600	<b>24</b>	27.0	<b>3.90</b>
	Segmented Rubber	450	<b>18</b>	37.0	<b>5.30</b>
	Rubber Belt	450	<b>18</b>	36.0	<b>5.20</b>
<b>308D CR</b>	Steel Triple Grouser	450	<b>18</b>	32.4	<b>4.70</b>
	Steel Triple Grouser	600	<b>24</b>	24.0	<b>3.50</b>
	Segmented Rubber	450	<b>18</b>	33.0	<b>4.80</b>
	Rubber Belt	450	<b>18</b>	31.0	<b>4.50</b>

\*China and Korea only.

\*\*China only.

Model	Shoe Type	Shoe Width		Pressure	
		mm	in	kPa	psi
<b>311D LRR</b>	Triple	500	20	40.4	5.86
	Triple	600	24	34.3	4.97
	Triple	700	28	29.9	4.34
	Triple	770	30	27.5	3.99
	Segment Rubber	500	20	40.8	5.92
<b>312D</b>	Triple	500	20	41.8	6.08
	Triple	600	24	35.5	5.15
	Triple	700	28	31.0	4.50
	Triple	770	30	28.5	4.13
	Segment Rubber	500	20	44.0	6.38
<b>312D L</b>	Triple	500	20	39.4	5.71
	Triple	600	24	33.4	4.86
	Triple	700	28	29.2	4.25
	Triple	770	30	26.9	3.90
	Segment Rubber	500	20	41.5	6.02
<b>313C SR</b>	Triple	500	20	45.6	6.60
	Triple	600	24	38.7	5.60
	Triple	700	28	33.7	4.90
	Segment Rubber	500	20	45.5	6.60
<b>313C CR</b>	Triple	500	20	40.9	5.90
	Triple	600	24	34.7	5.00
	Triple	700	28	30.3	4.40
	Segment Rubber	500	20	41.0	5.90
<b>314D CR</b>	Triple	500	20	45.9	6.58
	Triple	600	24	38.8	5.56
	Triple	700	28	34.0	4.87
	Segment Rubber	500	20	48.0	6.95
<b>314D LCR</b>	Triple	500	20	42.3	6.02
	Triple	600	24	36.0	5.13
	Triple	700	28	31.3	4.45
	Segment Rubber	500	20	44.4	6.44
<b>315D L</b>	Triple	500	20	—	—
	Triple	600	24	40.7	5.90
	Triple	700	28	35.4	5.13
<b>319D L</b>	Triple	500	20	53.0	8.00
	Triple	600	24	44.0	6.00
<b>319D LN</b>	Triple	500	20	53.0	8.00
	Triple	600	24	44.0	6.00



Model	Shoe Type	Shoe Width		Pressure	
		mm	in	kPa	psi
<b>320D</b>	Triple	600	24	46.8	6.80
	Triple	700	28	40.8	5.90
	Triple	800	32	36.2	5.30
<b>320D L</b>	Triple	600	24	43.5	6.30
	Triple	700	28	38.0	5.50
	Triple	800	32	33.6	4.90
<b>320D RR</b>	Triple	600	24	51.6	7.50
	Triple	700	28	44.9	6.50
	Triple	800	32	39.8	5.80
<b>320D LRR</b>	Triple	600	24	47.8	6.90
	Triple	700	28	41.7	6.00
	Triple	800	32	36.8	5.30
<b>321D LCR</b>	Triple	600	24	48.6	7.10
	Triple	700	28	42.4	6.20
	Triple	800	32	37.5	5.50
<b>323D L</b>	Triple	600	24	46.0	6.67
	Triple	700	28	36.3	5.26
	Triple	800	31	31.9	4.63
	Triple	900	35	30.6	4.44
<b>323D LN</b>	Triple	500	20	55.0	7.98
	Triple	600	24	45.8	6.64
<b>323D SA</b>	Triple	550	22	58.5	8.48
<b>324D</b>	Triple	600	24	52.6	7.60
	Triple	700	28	43.8	6.40
	Triple	800	32	40.3	5.80
<b>324D L</b>	Triple	600	24	49.6	7.20
	Triple	700	28	40.9	5.90
	Triple	800	32	38.0	5.50

NOTE: Belgium sourced excavators have different ground pressures. See Technical Data Sheets.

Model	Shoe Type	Shoe Width		Pressure	
		mm	in	kPa	psi
<b>328D LCR</b>	Triple	600	24	63.0	9.10
	Triple	700	28	55.0	8.00
	Triple	850	33	46.0	6.70
<b>329D</b>	Triple	600	24	54.2	7.90
	Triple	700	28	47.0	6.80
	Triple	800	32	42.1	6.10
<b>329D L</b>	Triple	600	24	54.2	7.90
	Triple	700	28	47.0	6.80
	Triple	800	32	42.1	6.10
<b>336D</b>	Triple	600	24	70.1	10.20
	Triple	700	28	60.6	8.80
	Triple	800	32	54.0	7.80
<b>336D L</b>	Triple	600	24	64.9	9.40
	Triple	700	28	56.1	8.10
	Triple	800	32	50.1	7.30
	Triple	800	32	48.2	7.00
<b>336D – ES</b>	Triple	600	24	71.0	10.30
<b>345D</b>	Triple	600	24	81.2	11.80
	Triple	750	30	66.3	9.60
	Double	600	24	81.7	11.80
	Double	750	30	66.5	9.60
<b>345D L – FIX</b>	Triple	600	24	76.8	11.10
	Triple	750	30	62.5	9.10
	Triple	900	35	53.0	7.70
	Double	600	24	77.0	11.20
<b>345D L – VG</b>	Triple	600	24	85.2	12.40
	Triple	900	35	58.7	8.50
	Double	600	24	85.7	12.40
	Double	750	30	69.8	10.10
<b>365C L</b>	Double	750	30	97.8	14.18
<b>385C</b>	Double	650	26	126.2	18.30
<b>385C L</b>	Double	750	30	117.6	17.06

NOTE: Belgium sourced excavators have different ground pressures. See Technical Data Sheets.

## QUICK COUPLER SYSTEMS

Quick couplers can greatly increase a machine's versatility and productivity. They make it much easier to switch attachments which can increase utilization. Quick couplers also encourage changing buckets when the application changes, rather than continue to use a less efficient bucket. Example: An application that is predominately dirt with occasional pockets or seams of rock. Without a quick coupler the owner may choose to live with a rock bucket but, rock buckets are normally smaller and heavier which reduces performance in a dirt application. A quick coupler allows the use of the rock bucket in the rock and a GP bucket in the dirt.

Caterpillar offers two main types of quick couplers. The first is a dedicated type. A typical system substitutes hooks on the bucket for the pin-on hinges used with conventional buckets. The mating portion is pinned on the stick and bucket linkage. It slips into the hooks to secure the bucket or other attachment.

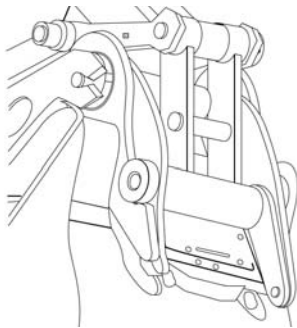

Dedicated  
Hook-type

### Advantages:

Bucket tip radius (distance from the bucket pivot point to the bucket tip) does not increase. Increased tip radius reduces curl and stick forces which can reduce the loadability of the bucket. The hook type coupler also does not add appreciable weight at the end of the stick. Keeping the tip radius and weight the same ensure no compromise in performance. The machine portion of the hook type coupler can be designed to allow more than one machine to use the same buckets.

### Disadvantages:

The hook type system requires special buckets. Conventional pin-on buckets cannot be used. The ability to use buckets on more than one machine requires careful application analysis. Larger machines generate forces that can destroy the wrong buckets. Smaller machines with the wrong bucket may develop loads in excess of the machine's capability. Even if the machine can handle the loads, the tip radius may be too large to allow the bucket to load properly. With the flexibility of a quick coupler comes the responsibility to make sure the bucket or other attachments are properly sized for each application.

The second type of quick coupler is the pin grabber type. This device pins on the stick and bucket linkage and grabs the bucket pins on standard pin-on buckets.

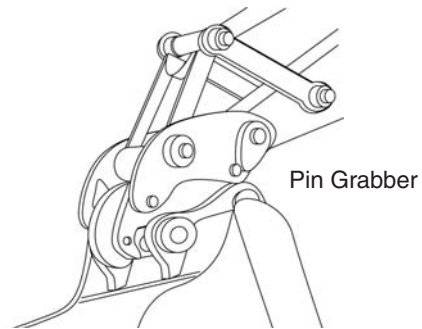

Pin Grabber

### Advantages:

The advantage of the pin grabber is that it will pick up standard pin-on buckets. No need to purchase new attachments that will fit the system.

### Disadvantages:

The pin grabber is mounted between the stick and the bucket which increases the tip radius. The amount of increase depends on the pin grabber's manufacturer. Increasing tip radius can compromise performance by decreasing bucket forces. The coupler also adds weight and reduces the payload capability.

Pin grabbers are required to mate up with existing bucket pins. Because different machines require different pin spreads and diameters, they offer very limited ability to match with buckets from other machines.

Both types of quick couplers offer cab activated ... this allows an attachment change in 30 seconds or less.

Pin grabber couplers allow work tools to be changed quickly — improving overall production and increasing machine versatility. A coupler is pinned on in place of the bucket with standard pins, and can be easily removed should the need arise to mount a tool directly to the stick.

Caterpillar has recently released the Center-Lock coupler, replacing the previous third-party offering designed by Miller. The Center-Lock™ Pin Grabber Coupler is designed for use on machines sized from 311-385 — and is designed to engage and disengage the same range of work tools as previous pin grabber couplers.

No dimensional or interface changes have been made to this coupler. However, a new patent-pending concept in the locking mechanism inside Center-Lock brings many benefits to the operator.

### **Confidence**

The Cat Center-Lock Pin Grabber Coupler gives operators confidence through its patent pending locking system and visible locking mechanism. The heart of the Center-Lock Coupler is the over center lock. This lock uses proven physical principles to keep the coupler locked tight.

### **Productivity**

A highly visible secondary lock gives operators confidence to make tool changes safely and quickly — saving time with every tool change. The action of Center-Lock is simpler and quicker than other pin grabber couplers and requires only curling the bucket cylinder to unlock and lock. The coupler action also allows the operator the change tools even in limited overhead conditions such as under power lines, bridge decks and street signs.

### **How Over-Center Technology Works**

Over-Center Locking Technology found only in the Center-Lock Coupler works on the same principle as a set of Vise-Grip® locking pliers. As you squeeze the handles to close the jaws there is some resistance until just past halfway, then the jaws seem to snap shut — automatically. That is the over center lock taking place.

The locking mechanism found inside the Center-Lock Pin Grabber Coupler works on the same principle. Once the lock is engaged and over center, the operator can only open the coupler, by moving a switch in the cab and extending the bucket cylinder.

While the coupler is locked, any forces applied from the front or rear pin will only cause the over center lock to close even tighter. This lock is integral to the design, not an afterthought. If the coupler is working, the lock is working.

### **Visible Secondary Lock**

The Center-Lock Pin Grabber Coupler was designed with the operator in mind. The secondary lock is clearly visible from the cab, providing an obvious indicator of coupler status: open or closed. The ability to see the lock on the front pin give the operator confidence and makes changing tools faster, while giving everyone on the job site reassurance that the Center-Lock is locked tight.

### **Secure Lock**

Once engaged, this arrangement is so secure that even if the hydraulic cylinder were removed entirely, the coupler would stay locked. Center-Lock Coupler uses proven principles of physics to stay tight. This concept has been proven with rigorous testing. Either the primary hook or secondary lock on its own is strong enough to hold the full weight of the work tool, keeping the locking system absolutely secure. And, the physical lock is backed up by positive “always on” hydraulic pressure and a counterbalance valve on the cylinder for additional layers of protection.

### **Productivity**

As with any quick coupler, the Center-Lock changes between attachments in seconds, allowing one machine to be used for multiple tasks on the job site. But Center-Lock offers many more productivity advantages.

The ease of operation and quickness of tool change-over maximizes productivity on the job site. The coupler is easy to operate, regardless of user skill level, and it's easier to train new operators to use. The ability to see when the coupler is open and closed saves time whenever a tool is changed. The elimination of the locking bar allows for operation regardless of boom, stick and machine position.

The Center-Lock Coupler can pick up many buckets in reverse “front shovel” position for better control in utility work and precise digging and grading operations. Many competitive buckets can be engaged, making the Center-Lock invaluable in mixed fleets or rental fleets.

**Improved Pin Grabber Coupler**

Center-Lock engages and disengages tools in a similar fashion to other pin grabber couplers. The difference with the Center-Lock Pin Grabber Coupler is found in the patent pending locking mechanism inside the coupler.

**Over-Center Technology** is the patent (pending) locking mechanism at the heart of the Center-Lock Pin Grabber Coupler. Once the locking mechanism passes "over center" the secondary lock is held firmly in place over the front bucket pin. Just like the jaws on a set of locking pliers, the secondary lock is held in place and it takes a specific action to release that lock.

**Cylinder walls** are much thicker and the diameter of the cylinder itself is much larger for increased closing power and resistance to extreme forces.

A **Counterbalance Valve** and positively pressurized hydraulics assure the coupler is locked on to the work tool, while isolating the cylinder from hydraulic shock.

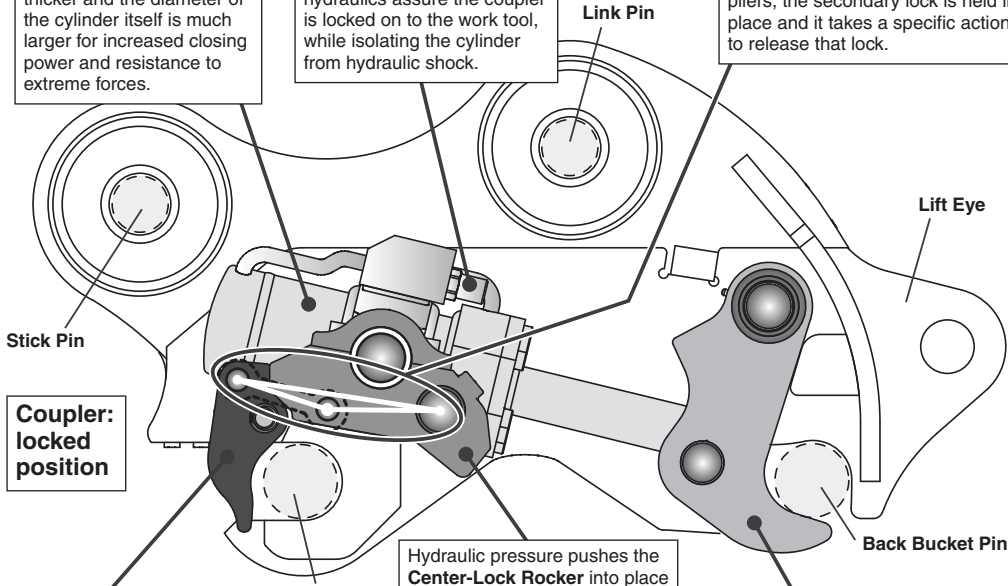

**Coupler: locked position**

A highly visible **Secondary Lock** clearly shows an operator when the coupler is locked on to the pin of a bucket or work tool. Visibility gives confidence to make tool changes quickly and safely — saving time with every tool change. And, the **Secondary Lock** has the strength to hold the full weight of a bucket if a back pin is missed when engaging.

Hydraulic pressure pushes the **Center-Lock Rocker** into place and keeps the Secondary Lock securely locked over the front bucket pin. Even in the event of hydraulic failure the coupler stays locked on to the pin.

**Primary Hook** grabs the back bucket pin and tightly secures the work tool.

**Coupler: un-locked position**

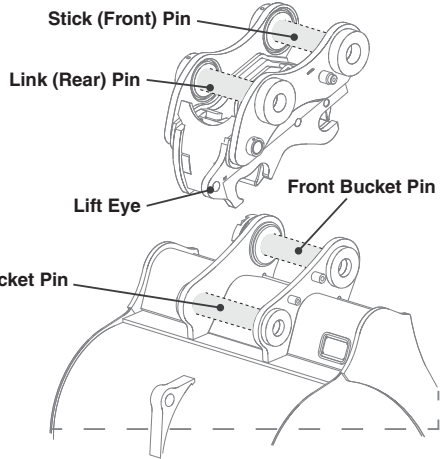
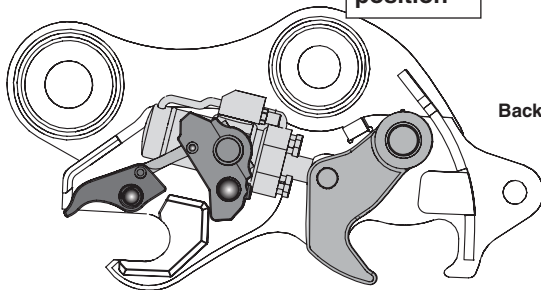

The Cat CW Series is available in a spindle and hydraulic version. A spindle version can easily be modified into a hydraulic version and vice versa.

**Additional Benefit:**

**Hoisting hooks** — To make the CW Series more versatile, hoisting hooks are available from 2 metric tons (2.2 tons) up to 20 metric tons (22 tons) capacity for maximum lifting capacity.



Hydraulic Version

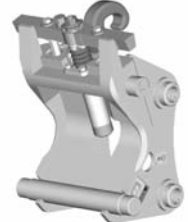

Spindle Version

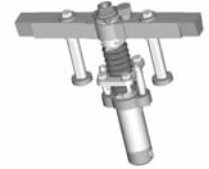

**Specifications**

		CW-05	CW-10	CW-20	CW-20S	CW-30	CW-30S		
Weight	kg	25	75	190	180	230	220		
	lb	55	165	419	397	507	485		
Dimensions									
Width	mm	175	310	550	420	550	420		
	in	6.9	12.2	21.7	16.5	21.7	16.5		
Length	mm	200	300	475	475	475	475		
	in	7.9	11.8	18.7	18.7	18.7	18.7		
Hoisting-hook	metric ton	2	4	5/10	5/10	5/10	5/10		
	ton	2.2	4.4	5.5/11.0	5.5/11.0	5.5/11.0	5.5/11.0		
Excavator-class	metric ton	<3.5	3.5-10.5	7.5-15	7.5-15	15-25	15-25		
	ton	<3.9	3.9-11.6	8.3-16.5	8.3-16.5	16.5-27.6	16.5-27.6		
Spindle Version		X	X	X	X	X	X		
Hydraulic Version		X	X	X	X	X	X		
		CW-40	CW-40S	CW-45	CW-45S	CW-55	CW-55S	CW-70	
Weight	kg	240	230	440	400	760	580	1300	
	lb	529	507	970	882	1676	1279	2866	
Dimensions									
Width	mm	550	420	690	550	830	560	840	
	in	21.7	16.5	27.2	21.7	32.7	22.0	33.1	
Length	mm	475	475	570	570	650	650	875	
	in	18.7	18.7	22.4	22.4	25.6	25.6	34.4	
Hoisting-hook	metric ton	5/10	5/10	14	14	20	20	20	
	ton	5.5/11.0	5.5/11.0	15.4	15.4	22.0	22.0	22.0	
Excavator-class	metric ton	20-30	20-30	25-40	25-40	35-65	35-65	65-90	
	ton	22.0-33.1	22.0-33.1	27.6-44.1	27.6-44.1	38.6-71.7	38.6-71.7	71.7-99.2	
Spindle Version		X	X	X	X	X	X	N/A	
Hydraulic Version		X	X	X	X	X	X	X	

CW-40 and CW-40S are not suitable for machine exceeding 27 metric tons (29.8 ton), which are used under heavy working conditions like rocky soils and demolition work, we highly recommend the usage of quick coupler CW-45(S).

- EAME
- Matching Guide

### Matching Guide

Machine	Linkage Family	Quick Coupler Model	
		Standard	Narrow
301.6C		CW-05	N/A
301.8C		CW-05	N/A
302.5C		CW-05	N/A
303C CR		CW-05	N/A
303.5C CR		CW-05	N/A
304C CR		CW-10	N/A
305C CR		CW-10	N/A
307C, 307D		CW-10	N/A
312D		CW-20	CW-20S
315D L		CW-30	CW-30S
319D		CW-30	CW-30S
320D	B1, CB	CW-40	CW-40S
320D RR	B1	CW-40	N/A
321D CR	B1	CW-40	N/A
323D L	B, C	CW-40	CW-40S
329D**	C	CW-40	CW-40S
329D	D	CW-45	CW-45S

Machine	Linkage Family	Quick Coupler Model	
		Standard	Narrow
336D	D	CW-45	CW-45S
336D	E	CW-45	CW-45S
345D	TB, UB	CW-55	CW-55S
365C L	VB, WB	CW-70	N/A
385C	HJ, JB	CW-70	N/A
M313D		CW-20	CW-20S
M315D		CW-20	CW-20S
M316D		CW-20	CW-20S
M318D		CW-30	CW-30S
M322D		CW-40	CW-40S
330C UHD*	UHD linkage	CW-40	CW-40S
345C L UHD*	UHD linkage	CW-40	CW-40S
365C L UHD*	UHD linkage	CW-40	CW-40S
385C L UHD*	UHD linkage	CW-40	CW-40S

\*Take note that UHD quick couplers have a special shape for optimal working range with Cat demolition work tools. Please contact your Cat dealer for UHD couplers for non-current Cat machines.

\*\*For operation under heavy working conditions, like rocky soils and demolition work, we highly recommend the usage of quick coupler CW-45(S).

### Machine Linkage

		307	312	315	B1	S	C	D	F/T	U/V/G
Pin diameters										
Front (stick)	mm	50	65	70	80	80	80	90	100	110
	in	2.0	2.6	2.8	3.1	3.1	3.1	3.5	3.9	4.3
Rear (link)	mm	50	65	70	80	80	80	90*	100**	90**
	in	2.0	2.6	2.8	3.1	3.1	3.1	3.5*	3.9**	3.5**
Pin spread range										
Minimum	mm	290	360	390	441	441	470	470	550	580
	in	11.4	14.2	15.4	17.4	17.4	18.5	18.5	21.7	22.8
Maximum	mm	312	420	463	516	516	520	520	600	640
	in	12.3	16.5	18.2	20.3	20.3	20.5	20.5	23.6	25.2
Face spread range										
Minimum	mm	178	220	277	306	306	347	380	420	495
	in	7.0	8.7	10.9	12.0	12.0	13.7	15.0	16.5	19.5
Maximum	mm	186	226	281	312	312	353	386	441	511
without shims	in	7.3	8.9	11.1	12.3	12.3	13.9	15.2	17.4	20.1
Maximum	mm	216	258	315	344	344	385	418	458	557
with shims	in	8.5	10.2	12.4	13.5	13.5	15.2	16.5	18.0	21.9
Other specifications										
Weight	kg	122	286	326	443	443	594	640	1035	1130
with pins	lb	269	631	719	977	977	1310	1411	2282	2491
Weight	kg	113	265	295	400	400	549	579	949	1025
without pins	lb	249	584	650	882	882	1210	1276	2092	2260
Pressure rating	bar	400	400	400	400	400	400	400	400	400
	psi	5802	5802	5802	5802	5802	5802	5802	5802	5802

\*Requires (2) sleeves.

\*\*Requires (3) sleeves.

## RIPPING & LOADING IN QUARRIES

The “Rip & Load” concept includes a large mass excavator equipped with a hydraulic quick coupler, a rock bucket and a ripper tine. The ripper tine is used to disrupt the in-situ rock formation, after which same excavator switches to the bucket to load the rock. This system is used where economical, environmental or legal issues prevent or restrict the use of explosives. In these situations, depending on geology, ripping either reduces the amount of explosives necessary, or replaces explosives all together.

### Advantages:

- Reduction or elimination of blasting costs.
- Reduced safety risks.
- Smaller environmental impact (less noise and vibrations).
- Less exposure to precipitation, resulting in less water damage.
- Less waste (up to 35% reduction).
- Less internal cracks, resulting in higher quality product.
- Work areas can be closer to existing infrastructures.
- Fewer machines and personnel.
- Increased versatility with quick coupler (different buckets, hammers).
- Lower Cost per Ton.

## Rip and Load Hourly Production

(With Hydraulic Quick Coupler)

Model	Metric Tons/Hour	Short Tons/Hour
345C/345D	150 - 300	165 - 330
365C	200 - 400	220 - 440
385C	300 - 500	330 - 550
5110B	400 - 600	440 - 660
5130B	600 - 800	660 - 880

### Rippability

Refer to “Tip Selection”, “Estimating Ripping Production” and “Use of Seismic Velocity Charts” in the Track-type Tractors section. This information generally applies to usage of a ripper tine on the mass excavator.

### Rippability Comparison between LHEX and LTTT

The excavator ripping technique is different from production ripping with a track-type tractor. The track-type tractor pulls the ripper(s) through the rock mass at a constant rate, whereas the excavator uses its stick- and curl forces to break material away from a horizontal or vertical face. Forward visibility in the excavator allows the operator to position the ripper tooth and attack geological discontinuities to assist the ripping process.

In ripping and loading, the ripper is typically used between 15% and 20% of the hour preparing the material. Tool change time, when using the hydraulic quick coupler, is insignificant with 2% to 6%. The remainder of the time is used for loading.

The ripping process improves bucket penetration which will increase service life of the bucket.



**Cat Hydraulic Quick Couplers for Mass Excavators**

Source: Cat Work Tools and Product Solutions — May not be available in all areas

(S) indicates narrow width version

		<b>CW-30 (S)</b>	<b>CW-40 (S)</b>	<b>CW-45 (S)</b>	<b>CW-55 (S)</b>	<b>CW-70</b>
Width	mm	550 (420)	550 (420)	690 (550)	830 (560)	840
	in	<b>21.7 (16.5)</b>	<b>21.7 (16.5)</b>	<b>27.2 (21.7)</b>	<b>32.7 (22.0)</b>	<b>33.1</b>
Length	mm	475	475	570	650	875
	in	<b>18.7</b>	<b>18.7</b>	<b>22.4</b>	<b>25.6</b>	<b>34.4</b>
<b>Models Available</b>						
<b>M – Mechanical</b>		M	M	M	M	
<b>S – Spindle</b>		S	S	S	S	H
<b>H – Hydraulic</b>		H	H	H	H	
<b>M318D</b>						
<b>320D</b>		B linkage	CB linkage			
<b>322C</b>			S linkage	D linkage		
<b>M322D</b>						
<b>323D</b>		B linkage	C linkage			
<b>329D</b>			C linkage	D linkage		
<b>336D</b>						
<b>345D</b>						
<b>365C</b>						
<b>385C</b>						

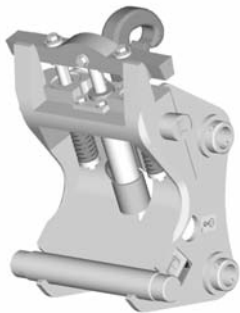

Cat CW-70 Quick Coupler



Cat TR-70 Ripper with QC

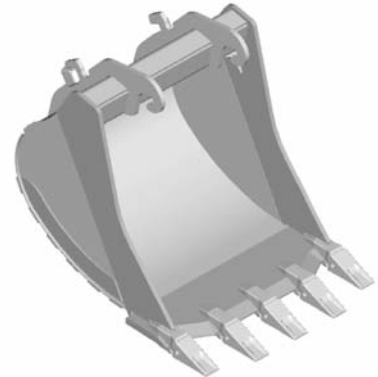

Cat Bucket with Quick Coupler Brackets

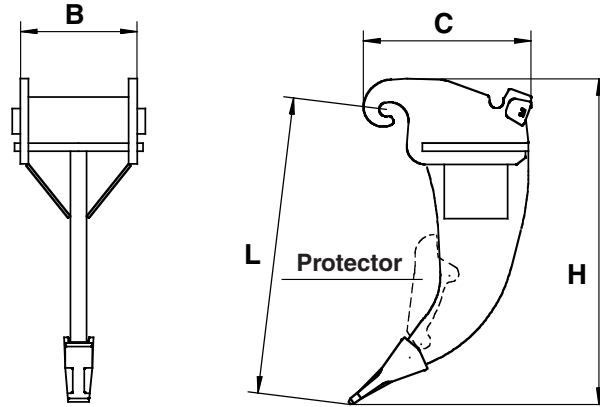

## Specifications

		TR-20-N		TR-30-N		TR-40-N		TR-45-N		TR-55-N		TR-70-N
Hinge Plate		CA-20	CA-20S	CA-30	CA-30S	CA-40	CA-40S	CA-45	CA-45S	CA-55	CA-55S	CA-70
Weight*	kg	300	270	400	370	460	420	820	770	1200	1140	1760
	lb	661	595	882	816	1014	926	1808	1698	2646	2513	3880
Dimensions*												
<b>B</b>	mm	630	500	630	500	630	500	800	660	965	695	1000
	in	24.8	19.7	24.8	19.7	24.8	19.7	31.5	26.0	38.0	27.4	39.4
<b>L</b>	mm	940		1105		1270		1435		1600		1700
	in	37.0		43.5		50.0		56.5		63.0		66.9
<b>C</b>	mm	725		725		725		900		1050		1325
	in	28.5		28.5		28.5		35.4		41.3		52.2
<b>H</b>	mm	1150		1250		1400		1650		1800		1980
	in	45.3		49.2		55.1		65.0		70.9		78.0
Wear parts												
Tip size (family)		R300		R350		R450		R500		R500		R550
Shank-protector**		N/A		N/A		X		X		X		X
Excavator-class	metric ton	7.5-15		15-25		20-30		25-40		35-65		65-90
	ton	8.3-16.5		16.5-27.6		22.0-33.1		27.6-44.1		38.6-71.7		71.7-99.2

\*Weight and dimensions include standard Quick-Coupler hinge plates and exclude shank-protector.

\*\*Shank-protector is optional.

## Cat Ripper Tine for CW Hydraulic Quick Couplers

Source: Caterpillar Work Tools and Product Solutions — May not be available in all areas

	TR-30	TR-40	TR-45	TR-55	TR-70
320D					
322C					
323D					
329D					
336D					
345D					
365C					
385C					

EQUIPMENT FOR ...	301.6C	301.8C	302.5C
<b>Undercarriage:</b>			
Standard	●	—	●
Variable Width	—	●	—
<b>Booms:</b>			
Swing	●	●	●
<b>Sticks:</b>			
Medium	—	●	●
Long	●	●	●
<b>Buckets (No. of)</b>	14	14	17
<b>Teeth:</b>			
Long	●	●	●
<b>Side Cutters:</b>			
One-Piece Blade	●	●	●
<b>Augers</b>	●	●	●
<b>Hydraulic Hammers</b>	●	●	●
<b>Crushers</b>	—	—	●
<b>Track Shoes:</b>	Steel Double Grouser 230 mm (9") Rubber Belt 230 mm (9")	Steel Double Grouser 230 mm (9") Rubber Belt 230 mm (9")	Steel Double Grouser 300 mm (12") Rubber Belt 300 mm (12")

**NOTE:** Number of buckets includes General Purpose, Trenching and Rock. Other types of buckets have not been included.  
All attachments may not be available in all sales areas.

EQUIPMENT FOR ...	303C CR	304C CR	305C CR
<b>Undercarriage:</b>			
Standard	●	●	●
<b>Booms:</b>			
Swing	●	●	●
Parallel Offset	●	—	—
<b>Sticks:</b>		<b>mm</b>	<b>ft</b>
Medium	●	1380	4'6"
Long	●	—	—
Long HD	—	1780	5'10"
<b>Buckets (No. of)</b>	13	13	13
<b>Teeth:</b>			
Long	●	●	●
Light Duty Long	●	●	●
Short	—	—	—
Wide	●	●	●
Penetration	●	●	●
Sharp — Corner	●	●	●
Sharp — Center	●	●	●
Sharp — Twin	●	●	●
Heavy Duty Long	—	—	—
Heavy Duty Abrasion	—	—	—
Abrasion	●	●	●
<b>Side Cutters:</b>			
One-Piece Blade	●	●	●
<b>Track Shoes:</b>	Steel Double Grouser 300 mm (12") Rubber 300 mm (12")	Triple Grouser 400 mm (16") Rubber Belt 400 mm (16")	Triple Grouser 400 mm (16") Rubber Belt 400 mm (16")

**NOTE:** Number of buckets includes General Purpose, Trenching and Rock. Other types of buckets have not been included.  
 All attachments may not be available in all sales areas.

# Excavators

## Summary of Major Attachments

● 307C ● 307D ● 308D CR SB

EQUIPMENT FOR ...	307C		307D		308D CR SB	
<b>Undercarriage:</b>						
Standard	●		●		●	
<b>Booms:</b>						
One-Piece Reach	●		●		—	
Swing	—		—		●	
Parallel Offset	●		●		—	
Variable Adjustable	—		—		—	
<b>Sticks:</b>	<b>mm</b>	<b>ft</b>	<b>mm</b>	<b>ft</b>	<b>mm</b>	<b>ft</b>
Medium	1670	5'6"	1670	5'6"	1670	5'6"
Long	2210	7'3"	2210	7'3"	2210	7'3"
<b>Buckets (No. of)</b>	10		10		10	
<b>Teeth:</b>						
Long	●		●		●	
Light Duty Long	—		—		—	
Short	●		●		●	
Wide	●		●		●	
Penetration	●		●		●	
Sharp — Corner	●		●		●	
Sharp — Center	●		●		●	
Sharp — Twin	●		●		●	
Heavy Duty Long	●		●		●	
Heavy Duty Abrasion	●		●		●	
Abrasion	—		—		—	
<b>Side Cutters:</b>						
One-Piece Blade	●		●		●	
<b>Track Shoes:</b>						
	Triple Grouser 450, 600 mm (18", 24") Rubber Segments 450 mm (18")		Triple Grouser 450, 600 mm (18", 24") Rubber Segments 450 mm (18")		Triple Grouser 450, 600 mm (18", 24") Rubber Segments 450 mm (18") Rubber Belt 450 mm (18")	

**NOTE:** Number of buckets includes General Purpose, Trenching and Rock. Other types of buckets have not been included.  
All attachments may not be available in all sales areas.

EQUIPMENT FOR ...	308D CR		311D LRR		312D	
<b>Undercarriage:</b>						
Standard		●		●		●
<b>Booms:</b>						
One-Piece Reach		●		●		●
Parallel Offset		—		—		—
<b>Sticks:</b>	<b>mm</b>	<b>ft</b>	<b>mm</b>	<b>ft</b>	<b>mm</b>	<b>ft</b>
Short		—		—	2100	6'11"
Medium	1670	5'6"	2250	7'5"	2500	8'2"
Intermediate		—	2600	8'6"	2800	9'2"
Long	2210	7'3"	2800	9'2"	3000	9'10"
<b>Buckets (No. of)</b>		10		5		5
<b>Teeth (J – GET):</b>						
Abrasion — HD		—		●		●
Long (G.P.)		●		●		●
Long — HD		—		●		●
Short		—		—		—
Short (Rock)		—		●		●
Penetration		—		●		●
Wide (Spade)		—		●		●
Sharp — Center		—		●		●
Sharp — Corner		—		●		●
<b>Side Cutters:</b>						
One-Piece Blade		●		●		●
<b>Hydraulic Hammers</b>		●		—		—
<b>Track Shoes:</b>						
		Triple Grouser 450, 600 mm (18", 24") Rubber Segments 450 mm (18") Rubber Belt 450 mm (18")		Triple Grouser 500, 600, 700, 770 mm (20", 24", 28", 30") Rubber Segments 500 mm (20")		Triple Grouser 500, 600, 700, 770 mm (20", 24", 28", 30") Rubber Segments 500 mm (20")
<b>Blade</b>		●		●		●

**NOTE:** Number of buckets includes General Purpose, Trenching and Rock. Other types of buckets have not been included.  
 All attachments may not be available in all sales areas.

# Excavators

## Summary of Major Attachments

- 312D ● 312D L ● 313C CR
- 313C SR ● 314D CR ● 314D LCR

EQUIPMENT FOR ...	312D L		312D* 312D L*		313C SR		313C CR		314D CR 314D LCR	
<b>Undercarriage:</b>										
Standard	—		●		●		●		●	
Long (L) — FIX	●		●		—		—		—	
<b>Booms:</b>										
One-Piece Reach	●		●		—		●		●	
Parallel Offset	—		—		●		—		—	
<b>Sticks:</b>	mm ft		mm ft		mm ft		mm ft		mm ft	
Short	2100 6'11"		2100 6'11"		—		—		—	
●	—		2500 8'2"		—		—		—	
●	—		3000 9'10"		—		—		—	
Medium	2500 8'2"		—		2130 7'0"		2500 8'2"		2500 8'2"	
Intermediate	2800 9'2"		—		—		—		2800 9'2"	
Long	3000 9'10"		—		—		3000 9'10"		3000 9'10"	
Medium HD	—		—		—		2500 8'2"		—	
<b>Booms:</b>										
Two-Piece VA	—		●		—		—		—	
<b>Buckets (No. of)</b>	5		5		3		5		5	
<b>Teeth:</b>										
Abrasion — HD	●		●		●		●		●	
Long (G.P.)	●		●		●		●		●	
Long — HD	●		—		●		●		●	
Short (Rock)	●		●		●		●		●	
Penetration	●		●		●		●		●	
Wide (Spade)	●		●		●		●		●	
Sharp — Center	●		●		●		●		●	
Sharp — Corner	●		—		●		●		●	
<b>Side Cutters:</b>										
One-Piece Blade	●		●		●		●		●	
<b>Track Shoes:</b>	Triple Grouser 600, 700, 770 mm (24", 28", 30")  Rubber Segments 500 mm (20")		Triple Grouser 500, 600, 700, 850, 900, 1400 mm (20", 24", 28", 34", 35", 56")		Triple Grouser 600, 700 mm (24", 28")  Rubber Segments 500 mm (20")		Triple Grouser 600, 700 mm (24", 28")  Rubber Segments 500 mm (20")		Triple Grouser 500, 600, 700 mm (20", 24", 28")  Rubber Segments 500 mm (20")	
<b>Blade</b>	●		—		●		●		●	

\*France sourced.

**NOTE:** Number of buckets includes General Purpose, Trenching and Rock. Other types of buckets have not been included.  
All attachments may not be available in all sales areas.

EQUIPMENT FOR ...	315D L		315D L**		319D L 319D LN	
<b>Undercarriage:</b>						
Long (L) — FIX	●		●		●	
Narrow (N)	—		—		●*	
Long Narrow (LN)	—		—		●	
Extra Long (EL)	—		—		●	
<b>Booms:</b>						
One-Piece Reach	●		●		●	
<b>Sticks:</b>	<b>mm</b>	<b>ft</b>	<b>mm</b>	<b>ft</b>	<b>mm</b>	<b>ft</b>
Short	1850	6'1"	1850	6'1"	1800	5'11"
●	2250	7'5"	2250	7'5"	2250	7'5"
●	2600	8'6"	2600	8'6"	—	
Medium	2900	9'6"	2900	9'6"	2700	8'10"
Long	3100	10'2"	3100	10'2"	3200	10'6"
<b>Booms:</b>						
One-Piece Mass	●		●		—	
Two-Piece VA	—		—		●*	
<b>Buckets (No. of)</b>	5		5		5	
<b>Teeth (J – GET):</b>						
Abrasion	—		—		●*	
Abrasion — HD	●		●		●	
Long (G.P.)	●		●		●	
Long — HD	●		—		●	
Short (Rock)	●		—		●	
Penetration	●		●		●	
Wide (Spade)	●		●		●	
Sharp	—		●		●*	
Sharp — Center	●		●		●	
Sharp — Corner	●		●		●	
<b>Teeth (K – GET):</b>						
General Duty	●		—		●	
Penetration	●		—		●	
Penetration Plus	●		—		●	
Wide	●		—		●	
Extra Duty	●		—		●	
Spike	●		—		●	
Double Spike	●		—		●	
<b>Side Cutters:</b>						
One-Piece Blade	●		—		●	
<b>Track Shoes:</b>	Triple Grouser 600, 700 mm (24", 28")		Triple Grouser 500, 600, 700 mm (20", 24", 28")		Triple Grouser 500, 600, 700 mm (20", 24", 28")	

\*France sourced.

\*\*EAME only.

**NOTE:** Number of buckets includes General Purpose, Trenching and Rock. Other types of buckets have not been included.  
 All attachments may not be available in all sales areas.



# Excavators

## Summary of Major Attachments

- 320D ● 320D L/LN ● 320D RR/LRR
- 321D LCR ● 323D L/LN ● 324D ● 324D L/LN

EQUIPMENT FOR ...	320D, 320D L 320D LN, 320D RR 320D LRR		321D LCR		323D L 323D LN		324D 324D L 324D LN	
<b>Undercarriage:</b>								
Standard	●		—		●		●	
Long (L) — FIX	●		●		●		●	
Long Narrow (LN)	●		—		●		●	
<b>Booms:</b>								
One-Piece Reach	●		●		●		●	
One-Piece Reach — HD	●		—		●		—	
<b>Sticks:</b>	<b>mm</b>	<b>ft</b>	<b>mm</b>	<b>ft</b>	<b>mm</b>	<b>ft</b>	<b>mm</b>	<b>ft</b>
Short	1900	6'3"	2900	9'6"	1900	6'3"	2500	8'2"
●	2500	8'2"	—		2500	8'2"	—	
●	2900	9'6"	—		2900	9'6"	—	
Medium	—		—		—		2950	9'8"
Long	3900	12'10"	—		—		3600	11'10"
Short — HD	2500	8'2"	—		2500	8'2"	—	
● — HD	2900	9'6"	—		2900	9'6"	—	
<b>Booms:</b>								
One-Piece Mass	●		—		●		●	
Two-Piece VA	●		●		●		—	
<b>Sticks:</b>	<b>mm</b>	<b>ft</b>			<b>mm</b>	<b>ft</b>	<b>mm</b>	<b>ft</b>
Short	1900	6'3"	—		1900	6'3"	2500	8'2"
●	2400	7'10"	—		2500	8'2"	—	
●	2900	9'6"	—		2900	9'6"	—	
<b>Bucket Family</b>	B1, C		B1		B, C		B1, CB1, DB	
<b>Buckets (No. of)</b>	18		4		18		7	
<b>Teeth:</b>								
Abrasion — HD	●		●		●		●	
Long (G.P.)	●		●		●		●	
Long — HD	●		●		●		●	
Short (Rock)	●		●		●		●	
Penetration	●		●		●		●	
Wide (Spade)	●		●		●		●	
Sharp — Center	●		●		●		●	
Sharp — Corner	●		●		●		●	
<b>Side Cutters:</b>								
One-Piece Blade	●		●		●		●	
Side Bar Protector	—		●		—		●	
<b>Track Shoes:</b>	Triple Grouser 600, 700, 800, 900 mm (24", 28", 31", 35") Double Grouser 600, 700 mm (24", 28")		Triple Grouser 600, 700*, 800 mm (24", 28", 32")		Triple Grouser 600, 700, 800, 900 mm (24", 28", 32", 35") Double Grouser 600, 700 mm (24", 28")		Triple Grouser 600, 700, 800 mm (24", 28", 32")	
<b>Quick Couplers</b>	●		●		●		●	
<b>Grapples</b>	●		●		●		●	
<b>Multi-Processors</b>	●		●		●		●	
<b>Hammers</b>	●		●		●		●	

\*Not available in Europe, Africa or Middle East.

**NOTE:** Number of buckets includes General Purpose, Trenching and Rock. Other types of buckets have not been included.  
All attachments may not be available in all sales areas.

Summary of Major Attachments  
 ● 329D ● 329D L/LN ● 336D ● 336D L/LN  
 ● 345D ● 345D L ● 365C L ● 385C ● 385C L

**Excavators**

EQUIPMENT FOR ...	329D		336D		345D		365C L		385C	
	329D L	329D LN	336D L	336D LN	345D L	345D L	365C L	365C L	385C L	385C L
<b>Undercarriage:</b>										
Standard	●		●		—		—		●	
Long (L) — VG	—		—		●		●		●	
Long (L) — FIX	●		●		●		—		—	
Long Narrow (LN)	●		●		—		—		—	
Extreme Service (ES)	—		—		—		●		—	
Long — HVG	—		—		●		—		—	
<b>Booms:</b>										
One-Piece Reach	●		●		—		●		●	
One-Piece Reach — HD	—		—		●		—		—	
One-Piece GP	—		—		—		—		●	
<b>Sticks:</b>	<b>mm</b>	<b>ft</b>	<b>mm</b>	<b>ft</b>	<b>mm</b>	<b>ft</b>	<b>mm</b>	<b>ft</b>	<b>mm</b>	<b>ft</b>
Short	2500	8'2"	—	—	—	—	2840	9'2"	2920	9'5"
●	—	—	—	—	—	—	3600	11'8"	3400	11'2"
●	—	—	3200	10'6"	—	—	4150	13'8"	3700	12'1"
●	—	—	3900	12'10"	—	—	4670	15'4"	4400	14'4"
Short — HD	—	—	—	—	2900	9'5"	—	—	5500	18'1"
● — HD	—	—	—	—	3400	11'2"	—	—	—	—
Medium	2950	9'8"	—	—	—	—	—	—	—	—
Long	3600	11'10"	—	—	—	—	—	—	—	—
<b>Booms:</b>										
One-Piece Mass	●		●		—		●		●	
One-Piece Mass — HD	—		—		●		—		—	
<b>Sticks:</b>	<b>mm</b>	<b>ft</b>	<b>mm</b>	<b>ft</b>	<b>mm</b>	<b>ft</b>	<b>mm</b>	<b>ft</b>	<b>mm</b>	<b>ft</b>
Short	2500	8'2"	2550	8'5"	2500	8'2"	2570	8'5"	2920	9'5"
●	—	—	—	—	3000	9'8"	3000	9'8"	3400	11'2"
<b>Bucket Family</b>	B1, CB1, DB		DB, TB1		TB, UB		VB, WB		HB, JB	
<b>Buckets (No. of)</b>	8		18		16		24		14	
<b>Teeth:</b>										
Abrasion — HD	●		●		●		—		—	
Long (G.P.)	●		●		●		●		●	
Long — HD	●		●		●		●		●	
Short (Rock)	●		●		●		●		●	
Penetration	●		●		●		●		●	
Penetration Plus	—		—		●		●		●	
Wide (Spade)	●		●		—		—		—	
Sharp — Center	●		●		—		—		—	
Sharp — Corner	●		●		—		—		—	
<b>Side Cutters:</b>										
One-Piece Blade	●		●		CWTS		—		—	
<b>Track Shoes:</b>	Triple Grouser 600, 700, 800 mm (24", 28", 32")		Triple Grouser 600, 750, 850 mm (24", 30", 33")		Double Grouser 600, 750 mm (24", 30") Triple Grouser 750, 900 mm (30", 35")		Double Grouser 650, 900 mm (26", 35")		Double Grouser 650, 750, 900 mm (26", 30", 35")	
<b>Quick Couplers</b>	●		●		●		●		●	
<b>Grapples</b>	●		●		CWTS		—		—	
<b>Multi-Processors</b>	●		●		CWTS		—		—	
<b>Hammers</b>	●		●		CWTS		—		—	

**NOTE:** Number of buckets includes General Purpose, Trenching and Rock. Other types of buckets have not been included.  
 All attachments may not be available in all sales areas.

# Excavators

## Summary of Major Attachments

● M313D ● M315D ● M316D ● M318D ● M322D

EQUIPMENT FOR ...	M313D		M315D		M316D		M318D		M322D	
<b>Undercarriage:</b>										
Wheeled	●		●		●		●		●	
<b>Booms:</b>										
One-piece	●		●		●		●		●	
VA	●		●		●		●		●	
<b>Backhoe Sticks:</b>	mm	ft	mm	ft	mm	ft	mm	ft	mm	ft
Short	2000	6'7"	2100	6'11"	2100	6'11"	2200	7'3"	2200	7'3"
Medium	2300	7'7"	2400	7'10"	2400	7'10"	2500	8'2"	2500	8'2"
Long	2600	8'6"	2600	8'6"	2600	8'6"	2800	9'2"	2900	9'6"
<b>Buckets (No. of)</b>	12		12		11		12		7	
<b>Teeth:</b>										
Abrasion	●		●		●		●		●	
Long (G.P.)	●		●		●		●		●	
Short (Rock)	●		●		●		●		●	
Penetration	●		●		●		●		●	
Wide	●		●		●		●		●	
Sharp	●		●		●		●		●	
<b>Cab Riser:</b>										
Fixed	●		●		●		●		●	
Hydraulic	—		—		—		—		—	
<b>Tires:</b>	10.00-20 16 PR 18R 19.5 XF 10.00-20 SR 600/40-22.5 11.00-20		10.00-20 16 PR 18R 19.5 XF 10.00-20 SR 600/40-22.5 11.00-20		10.00-20 16 PR 18R 19.5 XF 10.00-20 SR 600/40-22.5 11.00-20		10.00-20 16 PR 18R 19.5 XF 10.00-20 SR 600/40-22.5 11.00-20		10.00-20 16 PR 10.00-20 SR	

Work Tools	M313D	M315D	M316D	M318D	M322D
Clamshell	●	●	●	●	●
Ditch Cleaning Bucket	●	●	●	●	●
Grapples	●	●	●	●	●
Hammer Installation Kit	●	●	●	●	●

Work Tools	301.8C, 301.8C,	302.8C	303C CR, 303.8C CR,	304C CR, 308C CR	307D CR,	308D CR	311D L, RR, 312D L,	314D CR, 314D LCR	315D L	319D L, 319D LN	M313D, M315D	M316D, M318D,	M322D	320D, 320D RR,	321D CR, 323D	322C, 324D	329D	336D	345D	365C L	385C
Quick Coupler	x	x	x	x	x	x	x	x	x	x	x	x	x	x	x	x	x	x	x	x	x
Ditch Cleaning Bucket	x	x	x	x	x	x	x	x	x	x	x	x	x	x	x	x	x	x			
General Purpose Bucket	x	x			x	x	x	x	x	x	x	x	x	x	x	x	x	x	x	x	x
Heavy Duty Bucket			x																		
Rock Bucket			x		x							x	x	x	x	x	x	x	x	x	x
Tilt Bucket		x		x	x	x	x	x	x	x	x	x	x	x	x	x					
Thumb	x	x	x	x	x	x	x					x	x	x	x	x	x	x	x	x	x
Contractor's Grapple			x	x	x	x						x	x	x	x	x	x	x	x	x	x
Trash Grapple				x	x	x						x	x	x	x	x	x				
Orange Peel Grapple																					
Hydraulic Hammer			x	x	x	x	x	x	x	x	x	x	x	x	x	x	x	x			
Vibratory Plate Compactor																					
Shear			x	x	x	x						x	x	x	x	x	x	x	x	x	x
Multi-Processor							x					x	x	x	x	x	x	x	x	x	x

NOTE: Other attachments available upon request. Contact your Cat dealer.

**CYCLE TIME ESTIMATING CHARTS**

The digging cycle of the excavator is composed of four segments:

1. Load Bucket
2. Swing Loaded
3. Dump Bucket
4. Swing Empty

Total excavator cycle time is dependent on machine size (small machines can cycle faster than large machines) and job conditions. With excellent job conditions the excavator can cycle fast. As job conditions become more severe (tougher digging, deeper trench, more obstacles, etc.), the excavator slows down accordingly. As the soil gets harder to dig, it takes longer to fill the bucket. As the trench gets deeper and the spoil pile larger, the bucket has to travel farther and the upper structure has to swing farther on each digging cycle.

Spoil pile or truck location also affects cycle time. If a truck is located on the floor of the excavation beside material being moved, 10 to 17 second cycles are practical. The other extreme would be a truck or spoil pile located above the excavator 180° from the excavation.

In sewer construction work the operator may not be able to work at full speed because he has to dig around existing utilities, load the bucket inside a trench shield, or avoid people working in the area.

**The Cycle Time Estimating Chart** outlines the range of total cycle time that can be expected as job conditions range from excellent to severe. Many variables affect how fast the excavator is able to work. The chart defines the range of cycle times frequently experienced with a machine and provides a guide to what is an “easy” or a “hard” job. The estimator can then evaluate the conditions of his job and use the Cycle Time Estimating Chart to select the appropriate working range. A practical method of further calibrating the Cycle Time Estimating Chart is to observe excavators working in the field and correlate measured cycle times to job conditions, operator ability, etc.

The following table breaks down what experience has shown to be typical Cat excavator cycle times with

- no obstruction in the right of way
- above average job conditions
- an operator of average ability and
- 60°-90° swing angle.

These times would decrease as job conditions or operator ability improved and would get slower as conditions become less favorable.

**CYCLE TIME -vs- JOB CONDITION DESCRIPTION**

**Fastest Possible**

**Fastest Practical**

**Typical Range**

**Slow**



**KEY**

- A — Excellent
- B — Above Average
- C — Average
- D — Below Average
- E — Severe

- Easy digging (unpacked earth, sand gravel, ditch cleaning, etc.). Digging to less than 40% of machine’s maximum depth capability. Swing angle less than 30°. Dump onto spoil pile or truck in excavation. No obstructions. Good operator.
- Medium digging (packed earth, tough dry clay, soil with less than 25% rock content). Depth to 50% of machine’s maximum capability. Swing angle to 60°. Large dump target. Few obstructions.
- Medium to hard digging (hard packed soil with up to 50% rock content). Depth to 70% of machine’s maximum capability. Swing angle to 90°. Loading trucks with truck spotted close to excavator.
- Hard digging (shot rock or tough soil with up to 75% rock content). Depth to 90% of machine’s maximum capability. Swing angle to 120°. Shored trench. Small dump target. Working over pipe crew.
- Toughest digging (sandstone, caliche, shale, certain limestones, hard frost). Over 90% of machine’s maximum depth capability. Swing over 120°. Loading bucket in man box. Dump into small target requiring maximum excavator reach. People and obstructions in the work area.

**Cycle Time Estimating Chart**

Model		307C	308D CR	308D CR SB	311D LRR	312D, 312D L	315D L	319D L, 319D LN	M312, M313C, M315C, M313D, M315D	M315, M316C, M316D	M318C, M318D	M322C, M322D
Bucket Size	L yd <sup>3</sup>	280 0.37	220 0.30	220 0.30	450 0.59	520 0.68	520 0.68	800 1.05	610 0.80	750 0.98	900 1.18	1050 1.37
Soil Type		← Packed Earth →						← Sand/Gravel →				
Digging Depth	m ft	1.5 5'0"	1.8 6'0"	1.8 6'0"	1.5 5'0"	1.8 6'0"	3.0 10'0"	3.0 10'0"	3.0 10'0"	3.0 10'0"	3.0 10'0"	3.0 10'0"
Load Bucket	min	0.08	0.09	0.08	0.07	0.07	0.07	0.09	0.05	0.06	0.06	0.08
Swing Loaded	min	0.05	0.03	0.03	0.06	0.06	0.08	0.09	0.05	0.05	0.06	0.06
Dump Bucket	min	0.03	0.03	0.03	0.03	0.03	0.03	0.03	0.03	0.03	0.03	0.04
Swing Empty	min	0.06	0.06	0.08	0.05	0.05	0.06	0.07	0.04	0.04	0.05	0.05
Total Cycle Time	min	0.22	0.21	0.22	0.21	0.21	0.24	0.28	0.17	0.18	0.20	0.23

**Cycle Time Estimating Chart**

Model		320D	320D RR, 321D CR, 323D	324D	328D LCR	329D	336D	345D	365C L	385C
Bucket Size	L yd <sup>3</sup>	800 1.05	800 1.05	1000 1.31	N/A	1100 1.44	1400 1.83	2400 3.0	1900 2.5	3760 5.0
Soil Type		← Hard Clay →								
Digging Depth	m ft	2.3 8	2.3 8	3.2 10	N/A	3.2 10	3.4 11	4.0 13	4.2 14	5.6 18
Load Bucket	min	0.09	0.09	0.09	N/A	0.09	0.09	0.13	0.10	0.19
Swing Loaded	min	0.06	0.06	0.06	N/A	0.06	0.07	0.07	0.09	0.06
Dump Bucket	min	0.03	0.03	0.04	N/A	0.04	0.04	0.02	0.04	0.03
Swing Empty	min	0.05	0.05	0.06	N/A	0.06	0.07	0.06	0.07	0.07
Total Cycle Time	min	0.23	0.23	0.25	N/A	0.25	0.27	0.28	0.30	0.35

N/A = Not Applicable

CYCLE TIME ESTIMATING CHART														
CYCLE TIME	MACHINE SIZE CLASS													CYCLE TIME
	307C 308D CR 308D CR SB	311D	M312 M313C M313D 312D	M315C M316C M315D M316D 315D L	M318C 319D L 319D LN	M322C M322D 320D 320D RR 321D CR 323D	324D	328D LCR	329D	336D	345D	365C L	385C	
10 SEC.								N/A						0.17 min.
15								N/A						0.25 min.
20 SEC.								N/A						0.33 min.
25														0.42 min.
30 SEC.														0.50 min.
35														0.58 min.
40 SEC.														0.67 min.
45														0.75 min.
50 SEC.														0.83 min.
55														0.92 min.
60 SEC.														1.0 min.

N/A = Not Applicable

- Maximizing Production with a Mass Excavator

Cat 300 Series Mass Excavation booms and buckets coupled with the proper stick will help you move material faster and more efficiently in production excavation and loading applications. With the largest bucket, shortest stick and long undercarriage your excavator can often do the work of a larger machine. A longer stick and standard undercarriage make it ideal for loading on-highway trucks and general construction jobs.

## MAXIMIZING PRODUCTION WITH A MASS EXCAVATOR

4

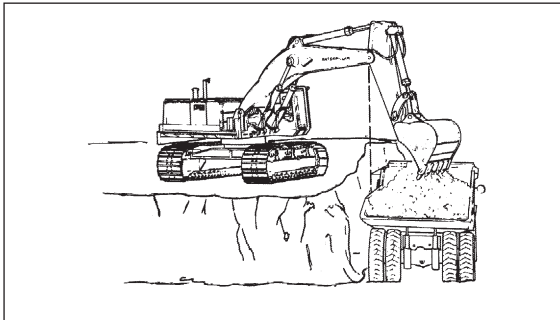

**Ideal Bench Height and Truck Distance** — For stable or consolidated materials, bench height should be about equal to stick length. For unstable materials it should be less. The most useful truck position is when the inside truck body rail is below the boomstick hinge pin.

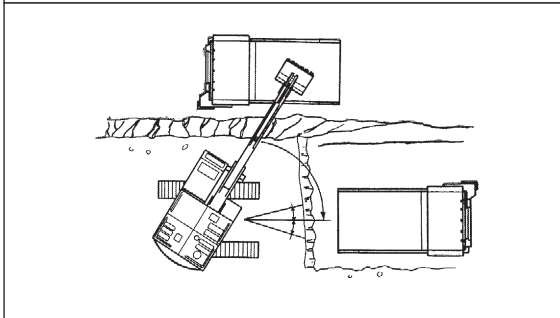

**Optimum Work Zone and Swing Angle** — For maximum production, the work zone should be limited to 15° either side of machine center or about equal to undercarriage width. Trucks should be positioned as close as possible to machine centerline. Two alternatives shown here.

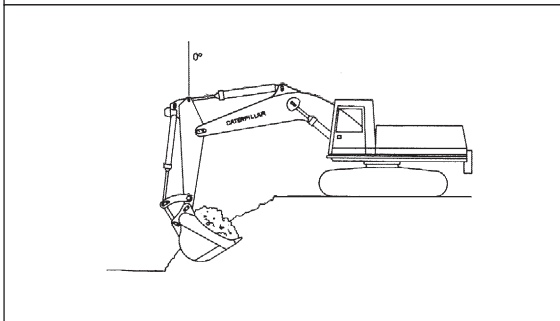

**Best Distance from the Edge** — The machine should be positioned so that the stick is vertical when the bucket reaches full load. If the unit is farther back, breakout force is reduced. If it is closer to the edge, undercutting may occur and time is wasted bringing the stick back out. Also, the operator should begin boom-up when the bucket is 75% of the way through the curl cycle. This should be as the stick nears the vertical position.

This example reflects the ideal situation. Not all points are usable on each job, but incorporation of as many of these points as possible will positively affect production.



**SELECTING A MASS EXCAVATOR**

Selecting a mass excavator model for optimum production requires matching the machine and bucket to the customer’s production requirements, material, and haulers. The following 6-Step selection process will help you to consider the key factors which will impact machine selection. Failure to consider these key elements in the selection process may result in choosing a machine that is too small to efficiently handle the desired bucket size or to meet the production requirement. Selecting a mass excavator which is too large may lead to excessive loader wait time, creating excessive “load shocks” into the hauler, and/or overloading the hauler capacity.

**Step 1**

*Determine the material type and bucket fill factor*

Refer to the bucket fill factors table.

Example:

Average Blasted Rock = 75 to 90%

**Step 2**

*Estimate the Cycle Time*

Refer to the cycle time estimating chart.

Example:

$\frac{365\text{B in Hard Rock Digging}}{\text{Shot Rock}} = .43 \text{ to } .52 \text{ minute}$

**Step 3**

*Calculate the Effective Cycles per Hour*

Divide the 60 minute hour by cycle time and adjust for availability and efficiencies.

Example:

<i>Cycle Time</i>	0.48 minute
$\frac{60 \text{ minute hour}}{\text{Cycle Time}}$	$\frac{60}{0.48} = 125$
<i>Operator Skill/Efficiency</i>	0.9 (90%)
<i>Machine Availability</i>	0.95 (95%)
<i>Gen Operational Efficiency</i>	0.83 (50 min/hr)
<i>Effective Cycles per Hour</i>	$125 \times .9 \times .95 \times .83 = 89$

**Step 4**

*Calculate the Required Bucket Capacity*

Divide hourly production requirement by effective cycles per hour, adjust for material density and fill factor.

Example (Metric):

*Hourly Production Required* 500 Tons/hour

*Effective cycles/hour* 89

$$\frac{\text{Hourly Production Required}}{\text{Effective cycles/hour}} = \frac{\text{Required Payload}}{\text{Volume}} = \frac{500}{89} = 5.6$$

*Material Density/Loose* 1.6 Ton/m<sup>3</sup>

$$\frac{\text{Required Payload}}{\text{Material Density/Loose}} = \frac{\text{Bucket Payload}}{\text{Volume}} = \frac{5.6}{1.6} = 3.5 \text{ m}^3$$

*Fill Factor* 0.85 (85%)

$$\frac{\text{Bucket Payload}}{\text{Fill Factor}} = \frac{\text{Nominal Bucket Size}}{\text{Volume}} = \frac{3.5}{.85} = 4.1 \text{ m}^3$$

Example (English):

*Hourly Production Required* 550 tons/hour

*Effective cycles/hour* 89

$$\frac{\text{Hourly Production Required}}{\text{Effective cycles/hour}} = \frac{\text{Required Payload}}{\text{Volume}} = \frac{550 \times 2000}{89} = 12,360 \text{ lb}$$

*Material Density/Loose* 2700 lb/yd<sup>3</sup>

$$\frac{\text{Required Payload}}{\text{Material Density/Loose}} = \frac{\text{Bucket Payload}}{\text{Volume}} = \frac{12,360}{2700} = 4.6 \text{ yd}^3$$

*Fill Factor* 0.85 (85%)

$$\frac{\text{Bucket Payload}}{\text{Fill Factor}} = \frac{\text{Nominal Bucket Size}}{\text{Volume}} = \frac{4.6}{.85} = 5.4 \text{ yd}^3$$

**Step 5**

*Select Mass Excavator for required bucket size*

Refer to Performance Handbook to compare machine models and bucket ranges. Confirm bucket type, size, and maximum material density in Specalog for desired model.

Example:

Required bucket capacity approximately  
 4.1 m<sup>3</sup> (5.4 yd<sup>3</sup>)

345B L Series II ME bucket capacity  
 to 3.5 m<sup>3</sup> (4.6 yd<sup>3</sup>)

365B L Series II ME bucket capacity  
 to 5.3 m<sup>3</sup> (6.9 yd<sup>3</sup>)

385B L ME bucket capacity to 5.6 m<sup>3</sup> (7.3 yd<sup>3</sup>)

Best Choice 365B Series II with 4.0 m<sup>3</sup> (5.2 yd<sup>3</sup>)  
 Rock Bucket rated to 1.8 Ton/m<sup>3</sup> (3000 lb/yd<sup>3</sup>)  
 material density in Specalog

*Important: Re-calculate Steps 2 - 5 based on cycle times of model selected.*

**Step 6**

*Select Haulers*

General rule for matching trucks is based on number of cycles to fill the truck.

ME: 4 to 6 passes

Front Shovels: 3 to 5 passes

Example (Metric):

*Bucket Selected* 4 m<sup>3</sup>  
*Volume in 5 passes* 5 × 4 × .85 = 17 m<sup>3</sup>  
*Payload* 17 × 1.6 = 27.2 Tons  
*Consider weight of Liners* 27.2 + 2 = 29.2 Tons

*Suitable Truck Match Options:*

*735 with capacity* 19.2 m<sup>3</sup>/31.8 t  
*769D with capacity* 24.2 m<sup>3</sup>/37.9 t

Example (English):

*Bucket Selected* 5.2 yd<sup>3</sup>  
*Volume in 5 passes* 5 × 5.2 × .85  
 = 22.1 yd<sup>3</sup>  
*Payload* 22.1 × 2700  
 = 59,670 lb  
*Consider weight of Liners* 59,670 + 4400 lb  
 = 64,070 lb

*Suitable Truck Match Options:*

*735 with capacity* 25.1 yd<sup>3</sup>/70,000 lb  
*769D with capacity* 31.7 yd<sup>3</sup>/83,570 lb

**EARTHMOVING PRODUCTION**

As with any other piece of material handling equipment, excavator earthmoving production is dependent on average bucket payload, average cycle time and job efficiency. If an estimator can accurately predict excavator cycle time and bucket payload, a machine's earthmoving production can be derived from the following formula.

$$\begin{aligned} \text{m}^3 (\text{yd}^3)/60 \text{ min hr} &= \text{Cycles}/60 \text{ min hr} \times \text{Avg.} \\ &\quad \text{Bucket Payload in m}^3 \\ &\quad (\text{yd}^3) \\ \frac{\text{m}^3 (\text{yd}^3)/60 \text{ min hr}}{60 \text{ min/hr}} &= \\ \frac{\text{Cycle Time} - \text{min}}{\text{Cycle Time} - \text{min}} &\times \text{Avg. Bucket Payload} \\ &\quad \text{in m}^3 (\text{yd}^3) \\ \text{Avg. Bucket Payload} &= \text{Heaped Bucket Capacity} \\ &\quad \times \text{Bucket Fill Factor} \\ \text{Actual m}^3 (\text{yd}^3)/\text{hr} &= \text{m}^3 (\text{yd}^3)/60 \text{ min hr} \times \\ &\quad \text{Job Efficiency Factor} \end{aligned}$$

The Production Estimating Tables (next page) will provide theoretical earthmoving production in cubic meters (yards) per hour if bucket size and cycle time can be estimated. The use of an average cycle time allows adjusting the estimated production for specific job sites and applications. For instance, estimating truck loading applications should include truck exchange times which extends the average cycle time and reduces production potential. The values in the table are based on a 60 minute work hour or 100% efficiency (a condition that is never achieved in reality). The estimator should apply a job efficiency factor to the figures in the table based on his judgment or knowledge of actual job conditions.

Areas outlined on the Production Estimating Table define the work ranges of excavators in the size classes of Cat 307 through 5230 ME Excavators. The upper limit on each area corresponds to the "fastest practical" cycle time for the machines. The width of each area corresponds to the range of bucket payload sizes the machine can handle. An unshaded box has been provided in each machine area to provide a guide indicating that the upper limit of earthmoving production is being approached. When working beyond the values in the white area, the estimator should be certain that excellent job conditions will be encountered (easy digging, shallow trench, good operator, etc.).

The Production Estimating Table can also serve as a guide when selecting the proper size machine to do a job, as is shown in the following example.

Example problem (Metric)

Contractor has a job to move 15 300 Bm<sup>3</sup> (19 100 Lm<sup>3</sup> considering 25% swell factor) of wet sandy loam material in rear dump on-highway trucks which will be loaded by an excavator. Average face depth will be 2.4 m with 60-90 degree average swing angle. Ten days are available to do the work. Contractor plans to work 10 hrs/day and estimates a 50 min. work hour (83% job efficiency). He has two excavators that could be made available to do the work — a 320 with 1.0 m<sup>3</sup> bucket or a 336 with 1.9 m<sup>3</sup> bucket. Experience has shown that either machine can get its rated capacity in the sandy loam soil. Could this job be done with either machine or will the 336 have to be used?

*Solution:* The excavator must produce 1900 Lm<sup>3</sup>/Day (19 100 Lm<sup>3</sup> ÷ 10 Days) which means the required average hourly rate will be 190 Lm<sup>3</sup>/60 Min. Hr. (1900 Lm<sup>3</sup>/Day ÷ 10 hrs/day). Further considering the 83% job efficiency, the excavator's capability will have to be 230 Lm<sup>3</sup>/50 min hr.

The production estimating table shows that the 320 with a 1.0 m<sup>3</sup> bucket would have to achieve a 17.1 sec. average cycle time to produce the required 190 Lm<sup>3</sup>/60 min. hr. With job efficiency applied a 15.0 second average cycle time is required to produce the 230 Lm<sup>3</sup>/50 min. hr. The 336 with a 1.9 m<sup>3</sup> bucket could obtain the same 60 min. hr. production level with a 35 second average cycle, or 30 second cycles to meet the 50 min. hr. production requirement. The cycle times estimating chart shows that the 320 would be working near its maximum capability to meet the production requirement, whereas, the 336 could handle the job easily. This information can then be weighed against what else is known about the job (reach requirements, job conditions, operator ability, etc.) to decide whether or not the larger machine is needed.

Example problem (English)

Substitute these English values in the preceding problem:

Job — 20,000 BCY (25,000 LCY considering 25% swell).

Average face depth — 8-12 ft

320 L with 1.25 yd<sup>3</sup> bucket or 336 with 2.5 yd<sup>3</sup> bucket.

*Solution:* The excavator must produce 2500 LCY/Day, which means the required average hourly rate will be 250 LCY/60 min hr. Further considering the 83% job efficiency the excavator's capability will have to be 300 LCY/50 min hr.

The same concluding comments regarding the Production Estimating Table apply here as in the Metric example.

**Cubic Meters per 60 Minute Hour\***

ESTIMATED CYCLE TIMES		ESTIMATED BUCKET PAYLOAD** — LOOSE CUBIC METERS																		ESTIMATED CYCLE TIMES		
Cycle Time		0.2	0.3	0.5	0.7	0.9	1.1	1.3	1.5	1.7	1.9	2.1	2.3	2.5	2.7	2.9	3.1	3.3	3.5	4.0	Cycles Per Min.	Cycles Per Hr.
Seconds	Min.																					
10.0	0.17																				6.0	360
11.0	0.18																				5.5	330
12.0	0.20	60	90	150	210	270															5.0	300
13.3	0.22	54	81	135	189	243	297	351	405	459	513	567	621	675	729	783	837	891	945	1080	4.5	270
15.0	0.25	48	72	120	168	216	264	312	360	408	456	504	552	600	648	696	744	792	840	960	4.0	240
17.1	0.29	42	63	105	147	189	231	273	315	357	399	441	483	525	567	609	651	693	735	840	3.5	210
20.0	0.33	36	54	90	126	162	198	234	270	306	342	378	414	450	486	522	558	544	630	720	3.0	180
24.0	0.40	30	45	75	105	135	165	195	225	255	285	315	345	375	405	435	465	495	525	600	2.5	150
30.0	0.50	24	36	60	84	108	132	156	180	204	228	252	276	300	324	348	372	396	420	480	2.0	120
35.0	0.58	20	31	51	71	92	112	133	153	173	194	214	235	255	275	296	316	337	357	408	1.7	102
40.0	0.67					81	99	177	135	153	171	189	207	225	243	261	279	297	315	360	1.5	90
45.0	0.75									133	148	164	179	195	211	226	242	257	273	312	1.3	78
50.0	0.83																				1.2	72

**Cubic Yards per 60 Minute Hour\***

ESTIMATED CYCLE TIMES		ESTIMATED BUCKET PAYLOAD** — LOOSE CUBIC YARDS																		ESTIMATED CYCLE TIMES		
Cycle Time		0.25	0.50	0.75	1.00	1.25	1.50	1.75	2.00	2.25	2.50	2.75	3.00	3.25	3.50	3.75	4.00	4.50	5.00	5.25	Cycles Per Min.	Cycles Per Hr.
Seconds	Min.																					
10.0	0.17																				6.0	360
11.0	0.18																				5.5	330
12.0	0.20	75	150	225	300	375															5.0	300
13.3	0.22	67	135	202	270	337	404	472	540	607	675	742	810	877	945	1012	1080	1215	1350	1417	4.5	270
15.0	0.25	60	120	180	240	300	360	420	480	540	600	660	720	780	840	900	960	1080	1200	1260	4.0	240
17.1	0.29	52	105	157	210	262	315	367	420	472	525	577	630	682	735	787	840	945	1050	1102	3.5	210
20.0	0.33	45	90	135	180	225	270	315	360	405	450	495	540	585	630	675	720	810	900	945	3.0	180
24.0	0.40	37	75	112	150	187	225	262	300	337	375	412	450	487	525	562	600	675	750	787	2.5	150
30.0	0.50	30	60	90	120	150	180	210	240	270	300	330	360	390	420	450	480	510	600	630	2.0	120
35.0	0.58	36	51	77	102	128	154	180	205	231	256	282	308	333	360	385	410	462	513	535	1.7	102
40.0	0.67					112	135	157	180	202	225	247	270	292	315	337	360	405	450	472	1.5	90
45.0	0.75									180	200	220	240	260	280	300	320	360	400	409	1.3	78
50.0	0.83																				1.2	72

**Job Efficiency Estimator**

Work Time/Hour	Efficiency
60 Min	100%
55	91%
50	83%
45	75%
40	67%

\*Actual hourly production = (60 min. hr. production) × (Job Efficiency Factor)

\*\*Estimated Bucket Payload = (Amount of Material in the Bucket) × (Bucket Fill Factor)

Unshaded area indicates average production.

**Cubic Meters/Yards per 60 Minute Hour\***

ESTIMATED CYCLE TIMES		ESTIMATED BUCKET PAYLOAD** — LOOSE CUBIC METERS/YARDS											ESTIMATED CYCLE TIMES	
Cycle Time		5.0	6.0	7.0	8.0	9.0	10.0	11.0	12.0	13.0	14.0	15.0	Cycles Per Min.	Cycles Per Hr.
Seconds	Min.													
15.0	0.25	1200	1440	1680	1920	2160	2400	2640	2880	3120	3360	3600	4.0	240
17.1	0.29	1050	1260	1470	1680	1890	2100	2310	2520	2730	2940	3150	3.5	210
20.0	0.33	900	1080	1260	1440	1620	1800	1980	2160	2340	2520	2700	3.0	180
24.0	0.40	750	900	1050	1200	1350	1500	1650	1800	1950	2100	2250	2.5	150
30.0	0.50	600	720	840	960	1080	1200	1320	1440	1560	1680	1800	2.0	120
35.0	0.58	510	612	714	816	918	1020	1122	1224	1326	1428	1530	1.7	102
40.0	0.67	450	540	630	720	810	900	990	1080	1170	1260	1350	1.5	90
45.0	0.75	390	468	546	624	702	780	858	936	1014	1092	1170	1.3	78
50.0	0.83	360	432	504	576	648	720	792	864	936	1008	1080	1.2	72
55.0	0.92	330	396	462	528	594	660	726	792	858	924	990	1.1	66
60.0	1.00	300	360	420	480	540	600	660	720	780	840	900	1.0	60

**Cubic Meters/Yards per 60 Minute Hour\***

ESTIMATED CYCLE TIMES		ESTIMATED BUCKET PAYLOAD** — LOOSE CUBIC METERS/YARDS										ESTIMATED CYCLE TIMES	
Cycle Time		16.0	17.0	18.0	19.0	20.0	21.0	22.0	23.0	24.0	25.0	Cycles Per Min.	Cycles Per Hr.
Seconds	Min.												
15.0	0.25	3840	4080	4320	4560	4800	5040	5280	5520	5760	6000	4.0	240
17.1	0.29	3360	3570	3780	3990	4200	4410	4620	4830	5040	5250	3.5	210
20.0	0.33	2880	3060	3240	3420	3600	3780	3960	4140	4320	4500	3.0	180
24.0	0.40	2400	2550	2700	2850	3000	3150	3300	3450	3600	3750	2.5	150
30.0	0.50	1920	2040	2160	2280	2400	2520	2640	2760	2880	3000	2.0	120
35.0	0.58	1632	1734	1836	1938	2040	2142	2244	2346	2448	2550	1.7	102
40.0	0.67	1440	1530	1620	1710	1800	1890	1980	2070	2160	2250	1.5	90
45.0	0.75	1248	1326	1404	1482	1560	1638	1716	1794	1872	1950	1.3	78
50.0	0.83	1152	1224	1296	1368	1440	1512	1584	1656	1728	1800	1.2	72
55.0	0.92	1056	1122	1188	1254	1320	1386	1452	1518	1584	1650	1.1	66
60.0	1.00	960	1020	1080	1140	1200	1260	1320	1380	1440	1500	1.0	60

**Job Efficiency Estimator**

Work Time/Hour	Efficiency
60 Min	100%
55	91%
50	83%
45	75%
40	67%

\*Actual hourly production = (60 min. hr. production) × (Job Efficiency Factor)

\*\*Estimated Bucket Payload = (Amount of Material in the Bucket)

= (Heaped Bucket Capacity) × (Bucket Fill Factor)

**NOTE:** For estimating truck loading production include approximately 0.7 minutes for truck exchange time.

**EXCAVATOR TRENCHING PRODUCTION**

When an excavator is used for trenching applications, a meaningful expression of work produced is the machine's trenching rate expressed in meters or lineal feet per hour or per day. Trenching rate depends on the earthmoving production of the excavator being used and the size of the trench being excavated. Earthmoving production converts to trenching production as follows:

$$\text{Lineal Meters of Trench per Hour} = \frac{\text{Cubic Meters Excavated per Hour}}{\text{Cubic Meters per Lineal Meter of Trench}}$$

$$\text{Lineal Meters of Trench per day} = (\text{Lineal Meters per Hour}) \times (\text{Trenching Hours per Day})$$

$$\text{Lineal Feet of Trench per Hour} = \frac{\text{Yd}^3 \text{ Excavated Per Hour}}{\text{Yd}^3 \text{ Per Lineal Foot of Trench}}$$

$$\text{Lineal Feet of Trench Per Day} = (\text{Lineal Ft Per Hour}) \times (\text{Trenching Hours Per Day})$$

For machines that work in trenching applications where they dig all of the time, the *Trenching Conversion Chart* provides easy conversion from  $\text{m}^3$  ( $\text{yd}^3$ ) per hour to m (lineal feet) per hour, if the excavating rate  $\text{m}^3/\text{hr}$  ( $\text{yd}^3/\text{hr}$ ) and trench volume  $\text{m}^3/\text{m}$  ( $\text{yd}^3/\text{ft}$ ) are known. The following examples demonstrate how the Trenching Conversion Chart can be used.

Example problem (Metric)

Contractor estimates that the 329 Excavator will produce  $200 \text{ Lm}^3/\text{hour}$ . Trench survey shows that the trench contains  $2.5 \text{ Lm}^3/\text{meter}$ . What trenching rate will the 329 produce?

*Solution:* Enter the horizontal axis of the Trenching Conversion Chart at  $200 \text{ m}^3/\text{Hour}$  and move up to the  $2.5 \text{ m}^3/\text{m}$  diagonal line. Then move left to the vertical axis of chart and read answer of  $80 \text{ m}/\text{hour}$ .

Example problem 2 (Metric)

Contractor knows he must produce 1000 meters of trench in every 10 hour work day. Survey shows that trench contains  $1.5 \text{ Bm}^3$  per lineal meter and soil swell factor is estimated at 30%. How much earthmoving production will the excavator have to provide in order to get the job done on time assuming a 50 min work hour? What Cat excavator will provide needed production at 6 meter maximum depth in sandy loam soil?

*Solution:* Determine trenching requirement 1000 meters in 10 hrs =  $100 \text{ m}/\text{h}$ . Convert  $\text{Bm}^3$  to  $\text{Lm}^3$  (excavator handles  $\text{Lm}^3$ )  $1.5 \text{ Bm}^3/\text{m} \times 1.30 = 2.0 \text{ Lm}^3/\text{m}$ . Enter vertical axis of trenching conversion chart at  $\text{m}/\text{h}$  and travel horizontally to diagonal line representing  $2.0 \text{ m}^3/\text{m}$ . Next move down to horizontal axis and read answer to  $200 \text{ Lm}^3/50 \text{ min hr}$ . Convert  $200 \text{ Lm}^3/50 \text{ min hr}$  to  $\text{Lm}^3/60 \text{ min hr} = 200 = 241 \text{ Lm}^3/60 \text{ min hr}$ .

Production estimating tables in this section show that  $241 \text{ Lm}^3/60 \text{ min hr}$  is within the capability of a 329 Excavator. Job should then be checked for reach and lifting requirements to make sure that the 329 could handle these aspects of the work.

Example problem (English)

Contractor estimates that a 329 Excavator will produce  $250 \text{ LCY}/\text{Hour}$ . Trench survey shows that the trench contains  $2.5 \text{ LCY}/\text{Foot}$ . What trenching rate will the 329 produce?

*Solution:* Enter the horizontal axis of the Trenching Conversion Chart at  $250 \text{ yd}^3/\text{hr}$ . Then move to the vertical axis of chart and read answer of  $100 \text{ ft}/\text{hr}$ .

The Trenching Conversion Chart can also be used to determine the required excavating rate if the contractor can define his trenching production requirement and the trench volume per lineal foot.



Example problem 2 (English)

Contractor knows he must produce 1000 ft of trench in every 10 hr work day. Survey shows that trench contains 1.6 BCY per lineal ft and soil swell factor is estimated at 25%. How much earthmoving production will excavator have to provide in order to get the job done on time assuming 50 min work hour? What Cat model will provide needed production at 8 ft depth in sandy loam soil?

**Solution:** Determine trenching requirement — 1000 ft in 10 Hrs. = 100 ft/hr  
Convert BCY to LCY —  $1.6 \text{ BCY/ft} \times 1.25 = 2.0 \text{ LCY/ft}$

Enter vertical axis of trenching conversion chart at 100 ft/hr and travel over to diagonal line representing 2.0 yd<sup>3</sup>/ft. Next move down to horizontal axis and read answer of 200 LCY/50 min hr.

Convert 200 LCY/50 min hr to LCY/60 min hr =  $\frac{200}{0.83} = 241 \text{ LCY/60 min hr}$

Production estimating tables in this section show that 241 LCY/60 min. hr. is within capability of a 329 Excavator. Job should then be checked for reach and lifting requirements to make sure that the 329 could handle these aspects of the work.



**TRENCHING CONVERSION CHART — CUBIC METERS (yd<sup>3</sup>) PER HOUR TO METER (ft) PER HOUR**

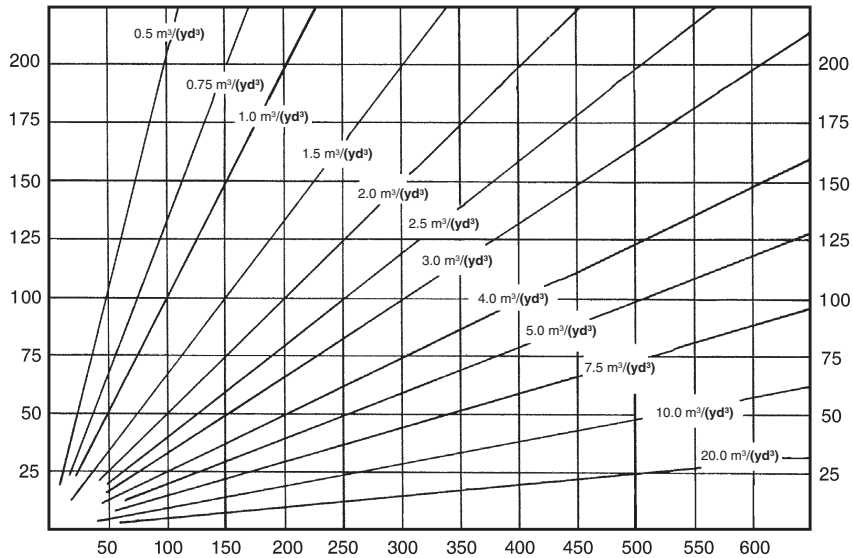

$m \text{ (ft.)} = m^3/(yd^3) \text{ Hr.}$   
 $Hr. = m^3/(yd^3) m \text{ (ft.)}$

Values in m<sup>3</sup>/m or yd<sup>3</sup>/ft

- If excavating rate has been calculated in Bm<sup>3</sup>/h use Bm<sup>3</sup>/m for Trench Volume/m.
- " " " " " " " " Lm<sup>3</sup>/h use Lm<sup>3</sup>/m for Trench Volume/m.
- " " " " " " " " BCY/Hr use BCY/ft for Trench Volume/ft.
- " " " " " " " " LCY/Hr use LCY/ft for Trench Volume/ft.



**Estimating Bucket Size**

In addition to the trenching calculations on the previous pages, an alternative method of figuring trenching production is the nomograph. Shown on the following pages, this particular nomograph can be used for estimating bucket size when given trench dimensions and linear production rate. The nomograph is quicker and easier than the preceding example because it does not require as many calculations, yet the accuracy is about the same within the normal limits of input data.

Be careful when entering and reading data from the nomographs because some scales increase from bottom to top, while others are the reverse. Do not be overly concerned with the precision as affected by pencil line width or reading to the hundredth of a m<sup>3</sup> (yd<sup>3</sup>). Remember that bucket fill factor, material density and cycle time are at best close estimates.

Example problem:

A sewer contractor owns a 329 with 2 piece boom and short stick. He wants to bid a contract for a 3.1 m (10') deep trench which measures 1.8 m (6') at the top and 1.2 m (4') at the bottom. He must dig 9 m/hr (30 ft/hr) to finish on time. The material is sand and gravel with a load factor of 0.90 and 100% bucket fill factor. He works 54 minutes per hour, half the time digging and half setting pipe. Cycle time is estimated at 23 seconds which includes a 90° swing angle.

- 1) Enter trench depth 3.1 m (10') on scale A and average trench width 1.5 m (5') on scale B.
- 2) Connect A and B and extend to scale C for bank volume per m (ft).
- 3) Enter estimated load factor (0.90) on scale D.
- 4) Connect C & D and extend to scale E for loose volume per m (ft).

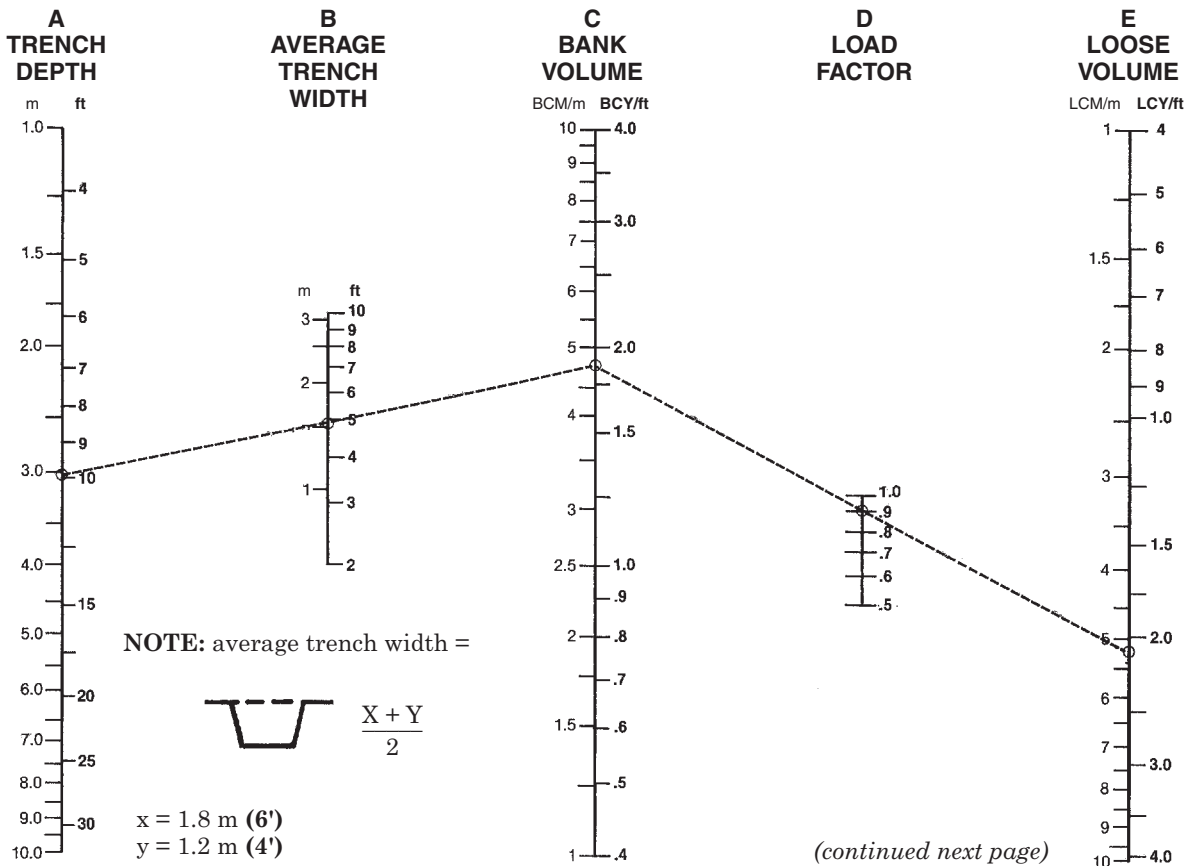

(get loose volume from scale E and enter on this page scale E)

- 5) Enter required linear production rate 9 m/h (30 t/hr) on scale G.
- 6) Connect E and G. Transfer hourly production rate from scale F to scale K (next page).

- 7) Estimate cycle time (23 sec) based on anticipated conditions and enter on scale H.
- 8) Estimate hourly digging time (27 min) and enter on scale I.
- 9) Connect H through I to scale J for cycles per hour.

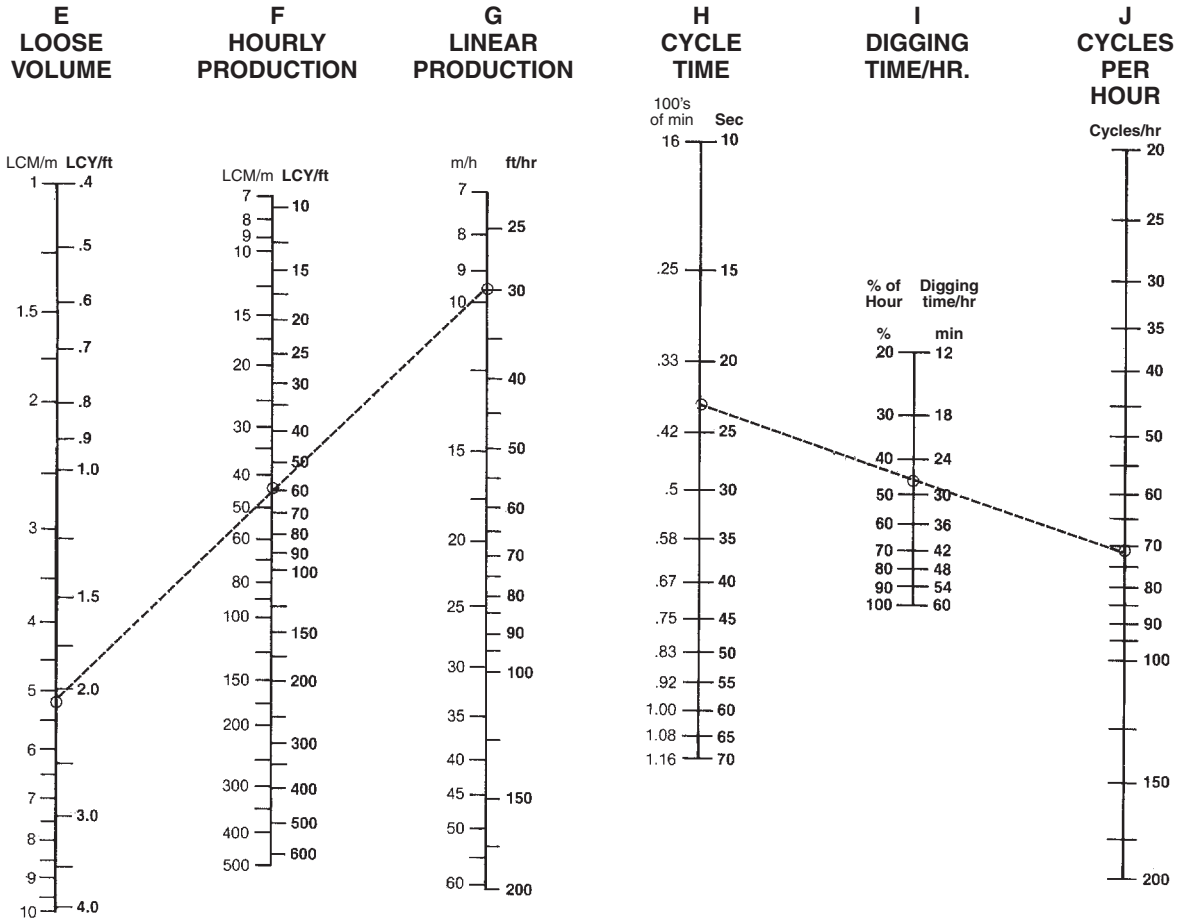

(get cycles per hour from scale J and enter on this page scale J)

- 10) Connect J through K to scale L for required volume per cycle.
- 11) Enter estimated bucket fill factor (100%) on scale M.
- 12) Connect L through M to scale N for required bucket size.

**NOTE:** Ensure bucket width does not exceed minimum trench width and also that weight of bucket and payload does not exceed machine working weight capacity (see lift capacity charts in this section).

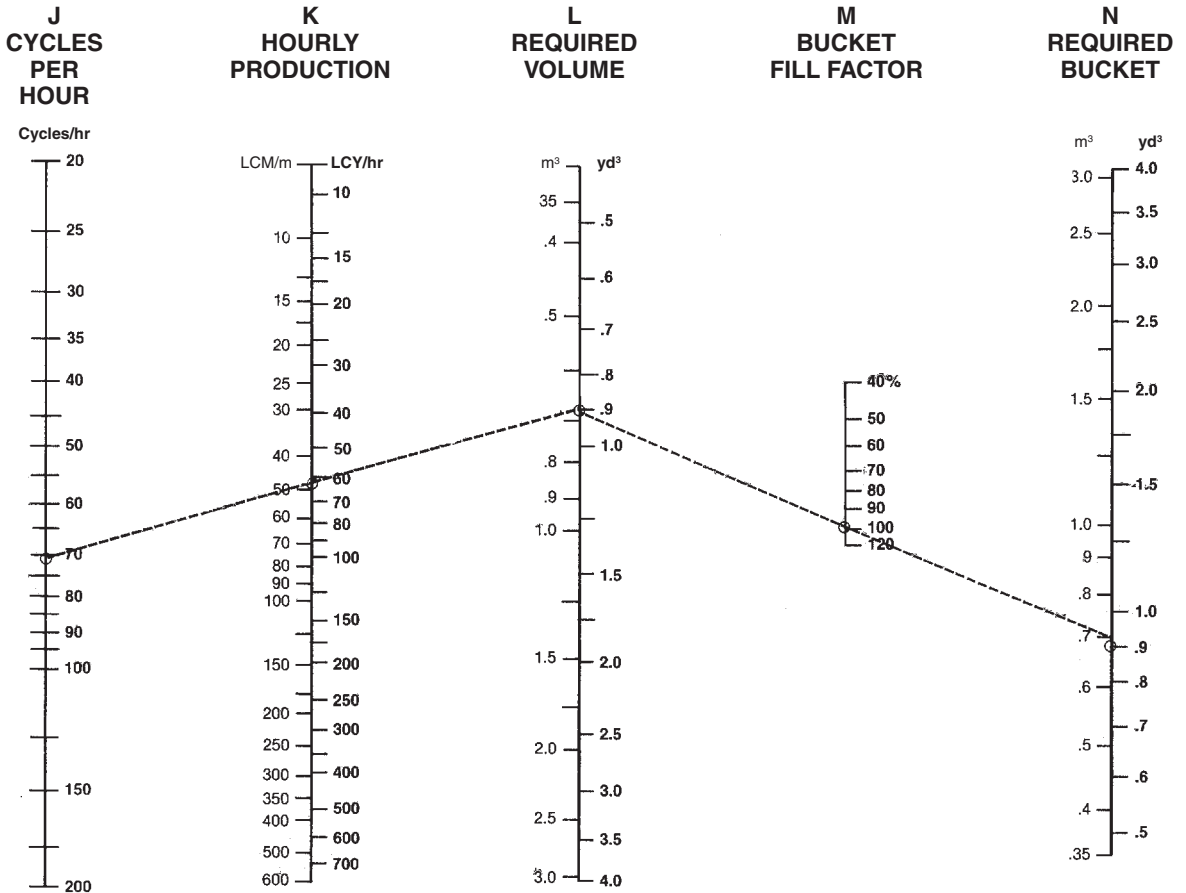

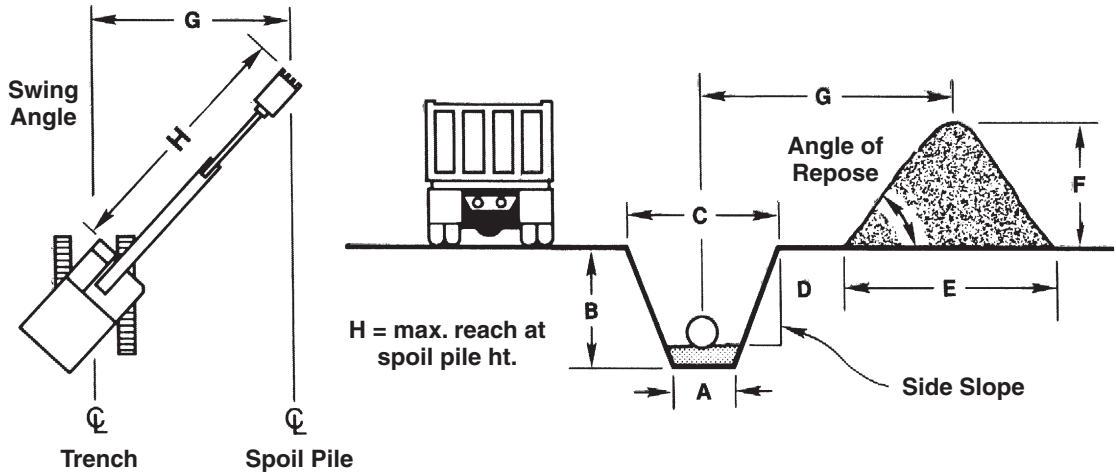

**Excavation Volumes Per Meter or Foot of Trench Length**

Metric version

Bank m<sup>3</sup>/meter = (Trench end area m<sup>2</sup>) × (one m)  
 Trench volume (Bm<sup>3</sup>/m) = ½ (A + C) × B  
 Spoil pile volume (Lm<sup>3</sup>/m) = (Bm<sup>3</sup>/m) × (1.00 + % Swell)

English version

Bank yd<sup>3</sup>/foot =  $\frac{(\text{Trench end area ft}^2) \times (\text{one ft})}{27}$

Trench volume (BCY/ft) =  $\frac{1/2 (A + C) \times B}{27}$

Spoil pile volume (LCY/ft) = (BCY/ft) × (1.00 + % Swell)

The following table provides a general guide to trench bottom width for various outside diameters of pipe.

Pipe Diameter		Trench Width		Pipe Diameter		Trench Width	
mm	ft/in	m	ft/in	mm	ft/in	m	ft/in
102	4"	0.49	1'7"	1524	5'0"	2.59	8'6"
152	6"	0.55	1'10"	1676	5'6"	2.80	9'2"
203	8"	0.61	2'0"	1829	6'0"	3.05	10'0"
254	10"	0.70	2'4"	1981	6'6"	3.26	10'8"
305	12"	0.76	2'6"	2134	7'0"	3.47	11'5"
381	15"	0.91	3'0"	2286	7'6"	3.69	12'1"
457	18"	1.03	3'5"	2438	8'0"	3.93	12'11"
533	1'9"	1.16	3'10"	2591	8'6"	4.15	13'7"
610	2'0"	1.25	4'1"	2743	9'0"	4.36	14'4"
686	2'3"	1.37	4'6"	2896	9'6"	4.54	14'11"
838	2'9"	1.58	5'2"	3048	10'0"	4.75	15'7"
914	3'0"	1.70	5'7"	3200	10'6"	4.99	16'5"
1067	3'6"	1.92	6'4"	3353	11'0"	5.21	17'1"
1219	4'0"	2.13	7'0"	3505	11'6"	5.43	17'10"
1372	4'6"	2.38	7'10"	3658	12'0"	5.64	18'6"

**NOTE:** Trench widths based on 1.25 Bc + 1.0 where Bc is the outside diameter of the pipe in feet.  
 Table courtesy of American Concrete Pipe Association

- Trenching Rate With Pipesetting
- Pipesetting Example Problem

**Trenching Production with Pipesetting**

On many sewer construction jobs the excavator does more than just dig the trench. Other tasks include handling the shoring system, placing bedding material, and lowering the pipe. The normal work procedure is to open a section of trench and then stop and make a pipe installation before going on to dig the next section of trench. At that point the key to trenching production is the total amount of time required to install each section of pipe. Pipe installation time can be broken down as follows: Digging time + other time = Total pipe installation time

Total Pipe Installation Time	Pipe Installed Per Hour
60 min	1 Pipe/hr
30 min	2 Pipe/hr
15 min	4 Pipe/hr
10 min	6 Pipe/hr

Digging Time can be calculated once the trenching rate has been calculated using the methods described earlier in this section. Once Digging Time has been calculated, it can be added to an estimate of “Other Time” to determine Total Pipe Installation Time. “Other Time” can be estimated based on a contractor’s judgment, experience, or actual measurement on a job. The following formula and table relate the trenching rate of the excavator to the time required to open a section of trench for pipe of various lengths.

$$\text{Digging Time (Min.)} = \frac{\text{Pipe Length (ft)}}{\text{Trenching Rate (ft/hr)}} \times 60 \text{ (Min/hr)}$$

Trenching Rate Ft. Per Hour	Time Required to Dig for Pipe of Various Lengths							
	8 ft Pipe		12 ft Pipe		16 ft Pipe		20 ft Pipe	
	Hours	Min.	Hours	Min.	Hours	Min.	Hours	Min.
20 ft/hr	0.400	24.00	0.600	36.00	0.800	48.00	1.000	60.00
40	0.200	12.00	0.300	18.00	0.400	24.00	0.500	30.00
60	0.130	8.00	0.200	12.00	0.260	16.00	0.333	20.00
80	0.100	6.00	0.150	9.00	0.200	12.00	0.250	15.00
100	0.080	4.80	0.120	7.20	0.160	9.60	0.200	12.00
120	0.060	4.00	0.100	6.00	0.120	7.20	0.167	10.00
140	0.057	3.43	0.086	5.14	0.114	6.86	0.143	8.57
160	0.050	3.00	0.075	4.50	0.100	6.00	0.125	7.50
180	0.044	2.66	0.067	4.00	0.089	5.33	0.111	6.67
200	0.040	2.40	0.060	3.60	0.080	4.80	0.100	6.00

This table can be used to show how an excavator that is capable of more trenching production will provide significant advantages even on jobs where the

machine does not dig all of the time. Consider 12,000' job with 12' sections of pipe (1000 pipe to be installed). Excavator “A” can work at 60 ft/hr while Excavator “B” is capable of producing 120 ft/hr. Table shows that Excavator “B” will only take 0.10 hr to do the same work. This means that over the course of installing the 1000 pipe the more productive machine will save 0.10 hr/pipe or 100 hours of working time.

Example problem (English)

The following example shows how trenching production can be calculated on a job where the excavator is also required to set pipe. This example is based on the assumption that the excavator’s earthmoving rate and the pipe installation time have already been estimated by the contractor.

*Problem:* Contractor estimates that the 350 Excavator will be able to produce 500 LCY/60 min. hr. Survey shows that an average cross section trench contains 3.2 BCY/ft and swell factor for sandy clay soil is estimated at 25%. How much trenching production can a contractor expect; assuming it takes 10.0 min. to install each 20 ft length of pipe after trench has been opened. Also assume 83% job efficiency — 50 min. work hour and 8 work hours out of a 9 hour shift. (0.5 hours for lunch and two 15 minute breaks.)

*Solution:*

Convert trench volume to LCY/ft:

$$1.25 (3.2 \text{ BCY/ft}) = 4.0 \text{ LCY/ft}$$

Convert Earthmoving rate to Trenching rate:

$$\frac{500 \text{ LCY/hr}}{4.0 \text{ LCY/ft}} = 125 \text{ ft/hr}$$

Calculate digging time for each pipe:

$$\frac{20 \text{ ft/pipe}}{125 \text{ ft/hr}} = 0.16 \text{ hr/pipe} = 9.6 \text{ min}$$

Calculate pipe installation time:

$$\begin{aligned} \text{Digging time} &= 9.6 \text{ min} \\ \text{Other time} &= 10.0 \text{ min} \\ \text{Pipe Installation time} &= 19.6 \text{ min} \end{aligned}$$

Calculate pipe installations/hour:

$$\frac{60 \text{ min/hr}}{19.6 \text{ min/pipe}} = 3.06 \text{ pipe/hr}$$

Calculate max. pipe installations/day:

$$8 \text{ hrs} (3.06 \text{ pipe/hr}) = 24.48 \text{ pipe/day}$$

Actual pipe/day:

$$0.83 (24.48 \text{ pipe/day}) = 20.3 - 20 \text{ pipe/day}$$

Actual feet/day:

$$(20 \text{ pipe/day}) \times (20 \text{ ft/pipe}) = 400 \text{ ft/day}$$

**385C FS**

<b>MODEL</b>	<b>385C FS</b>	
Sourcing	<b>Belgium</b>	
Flywheel Horsepower	390 kW	<b>523 hp</b>
Operating Weight*	90 600 kg	<b>199,740 lb</b>
Bucket Capacity Range (heaped)	5.7 m <sup>3</sup>	<b>7.4 yd<sup>3</sup></b>
Engine Model	<b>C18 ACERT</b>	
Rated Engine RPM	<b>1800</b>	
No. of Cylinders	<b>6</b>	
Bore	145 mm	<b>5.7"</b>
Stroke	183 mm	<b>7.2"</b>
Displacement	18.1 L	<b>1105 in<sup>3</sup></b>
Max. Hydraulic Pump Output at Rated RPM	2 × 490 L/min	<b>2 × 129 gpm</b>
Relief Valve Settings:		
Implement Circuits	32 000 kPa	<b>4640 psi</b>
Swing	35 000 kPa	<b>5075 psi</b>
Travel Circuits	26 000 kPa	<b>3770 psi</b>
Pilot Circuits	4100 kPa	<b>595 psi</b>
Maximum Drawbar Pull	592 kN	<b>133,200 lb</b>
Maximum Travel Speed at Rated RPM	<b>Two Speed</b>	
Low	2.8 km/h	<b>1.7 mph</b>
High	4.5 km/h	<b>2.8 mph</b>
Overall Track Length**	5.84 m	<b>19'2"</b>
Track Gauge	2.75 m	<b>9'0"</b>
Extended	3.51 m	<b>11'6"</b>
Track Shoe Widths	650 mm	<b>26"</b>
Ground Contact Area with Standard Shoe	6.54 m <sup>2</sup>	<b>70.4 ft<sup>2</sup></b>
Ground Pressures	138 kPa	<b>20.0 psi</b>
Fuel Tank Refill Capacity	1240 L	<b>328 U.S. gal</b>
Hydraulic System (includes tank)	995 L	<b>263 U.S. gal</b>
Hydraulic System	810 L	<b>214 U.S. gal</b>

\*Operating weight includes counterweight and full fuel.

\*\*Track length measured from center of idler to center of sprocket.

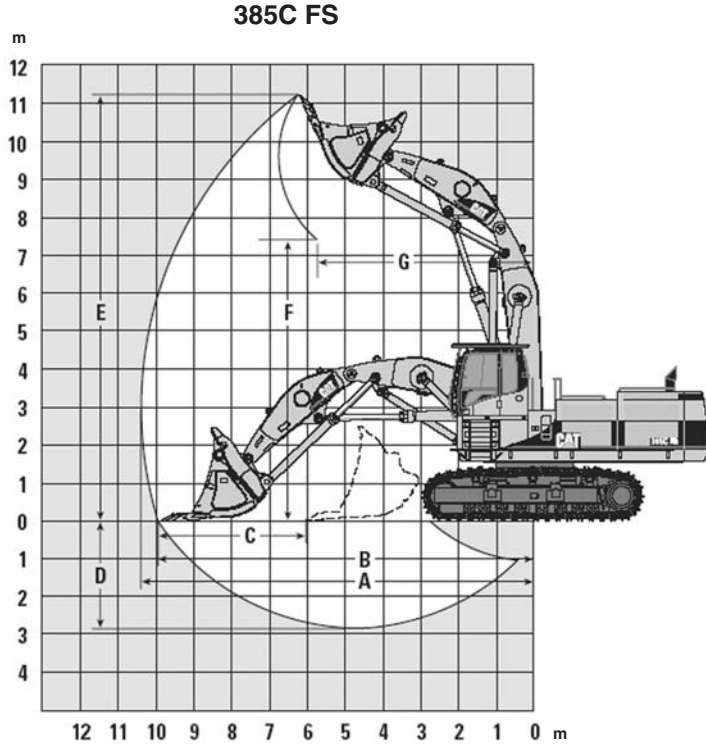

**385C FS**

Stick Length	3480 mm	11'5"
Boom Length	4600 mm	15'1"
Rock Bucket	5.2 m	17'1"
<b>A</b> Maximum Reach	10 350 mm	33'11"
<b>B</b> Maximum Reach at Ground Level	9900 mm	32'6"
<b>C</b> Maximum Level Crowd Distance	3920 mm	12'10"
<b>D</b> Maximum Digging Depth	2840 mm	9'4"
<b>E</b> Maximum Digging Height	11 260 mm	36'11"
<b>F</b> Maximum Dump Height	7430 mm	24'5"
<b>G</b> Reach at Maximum Dump Height	5690 mm	18'8"
Bucket Breakout Force (ISO)	538 kN	121,050 lb
Stick Breakout Force (ISO)	429 kN	96,530 lb

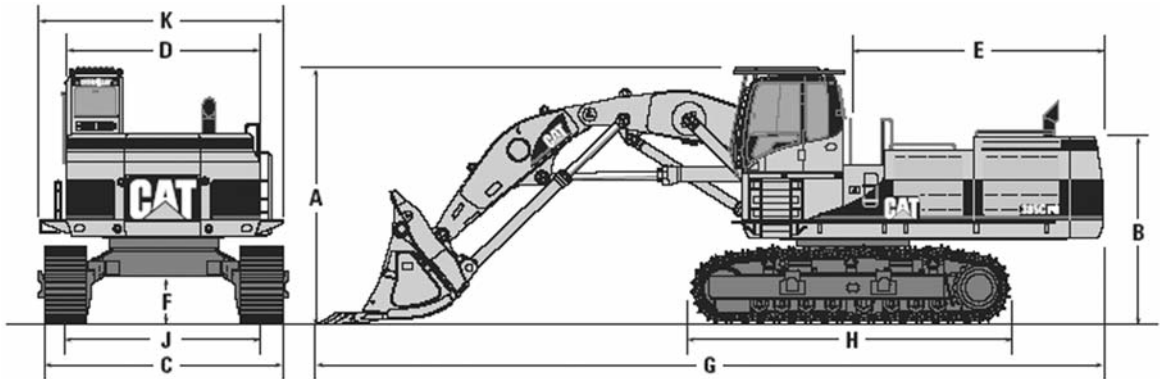

**385C FS**

Boom	4600 mm	15'1"
Stick	3480 mm	11'5"
<b>A</b> Boom Top Height	4500 mm	14'9"
Cab Top Height with FOPS	4660 mm	15'3"
Cab Top Height without FOPS	4520 mm	14'10"
<b>B</b> Engine Hood Height without Handrail	3460 mm	11'4"
<b>C</b> Overall Width		
650 mm (26") Shoes (retracted)	3400 mm	11'2"
750 mm (30") Shoes (retracted)	3500 mm	11'6"
650 mm (26") Shoes (extended)	4160 mm	13'8"
750 mm (30") Shoes (extended)	4260 mm	14'0"
<b>D</b> Upperstructure Width	3470 mm	11'5"
<b>E</b> Tail swing Radius	4590 mm	15'1"
<b>F</b> Minimum Ground Clearance	850 mm	2'9"
<b>G</b> Overall Length	14 250 mm	46'9"
<b>H</b> Track Length	5840 mm	19'2"
<b>J</b> Track Gauge Width		
Extended Position	3510 mm	11'6"
Retracted Position	2750 mm	9'0"





# MATERIAL HANDLING ARRANGEMENTS

## CONTENTS

330D Waste Handler	
Range Diagram and Specifications . . . . .	4-204
Lifting Capacities . . . . .	4-205
M318D MH, M322D MH	
Range Dimensions . . . . .	4-206
M318D MH Lifting Capacities . . . . .	4-207
M322D MH Lifting Capacities . . . . .	4-208
M325D MH, M325D LMH — Belgium Sourced	
Dimensions and Weights . . . . .	4-209
Range Dimensions . . . . .	4-209
Lifting Capacities . . . . .	4-210
325D MH	
Range Diagrams and Specifications . . . . .	4-218
Lifting Capacities . . . . .	4-219
330D MH	
Range Diagrams and Specifications . . . . .	4-221
Lifting Capacities . . . . .	4-222
345C MH	
Range Diagrams and Specifications . . . . .	4-224
Lifting Capacities . . . . .	4-225
385C MH	
Range Diagrams and Specifications . . . . .	4-227
Lifting Capacities . . . . .	4-228
Magnet Selection . . . . .	4-230
Grapple Selection . . . . .	4-230
Ferrous Scrap Specifications . . . . .	4-231

(Scrap specifications and classifications can be found in the Institute of Scrap Iron and Steel Inc.'s "Handbook". The common unit measure for the scrap industry is the gross ton which is 2240 pounds. However, short tons, net tons and metric tons may also be used.)

The versatility of Cat Excavators, plus their ability to be equipped in any number of ways, make them an effective, low cost way to handle scrap and other materials.

**NOTE:** Contact your Cat dealer for additional information on equipping Cat Excavators for material handling.

**330D Waste Handler Range Diagram**

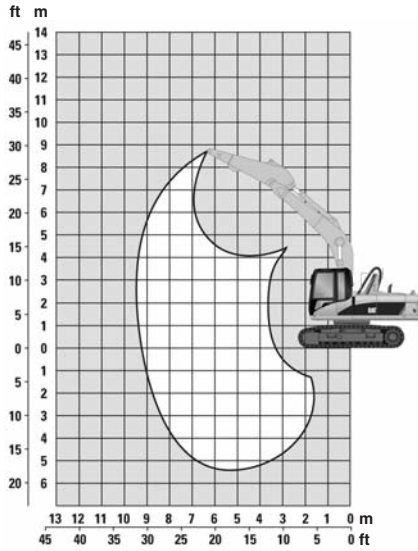

Model	330D Waste Handler	
Maximum height	8.9 m	29.18 ft
Maximum reach	9.45 m	31 ft

**330D Waste Handler Specifications**

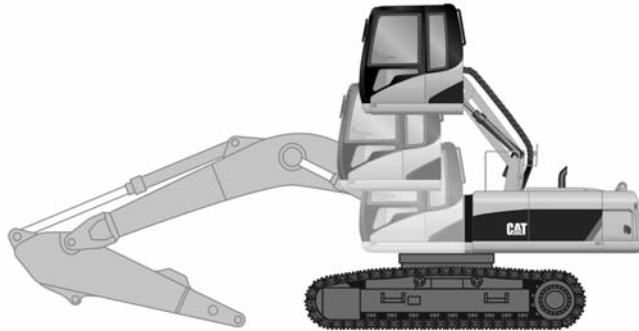
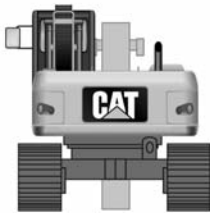

Model	330D Waste Handler	
Shipping Height	3255 mm	10.7 ft
Shipping Length	11 130 mm	36.5 ft
Tail Swing Radius	3500 mm	11.5 ft
Length to Centers of Rollers	4040 mm	13.25 ft
Track Length	5020 mm	16.5 ft
Ground Clearance	510 mm	1.67 ft
Track Gauge	2590 mm	8.5 ft
Shipping Width with 600 mm (23.5 in) Shoes	3190 mm	10.5 ft
Cab Height (with cab in raised position)	5775 mm	18.9 ft
Cab Height (with cab in lower position)	3180 mm	10.4 ft

## Lift Capacities

### 330D Waste Handler

**CONFIGURATION** – HD Reach Boom, WH 3.2 D Stick  
D Family Bucket Linkage and No Grapple

**UNDERCARRIAGE** – Long  
**SHOES** – 600 mm (23.5 in) Triple Grouser

















Load at  
Maximum Reach



Load Radius  
Over Front



Load Radius  
Over Side

		3.0 m/10.0 ft		4.5 m/15.0 ft		6.0 m/20.0 ft		7.5 m/25.0 ft		9.0 m/30.0 ft				m ft
														
7.5 m 25.0 ft	kg lb							*7600	*7600					
6.0 m 20.0 ft	kg lb							*7700 *16,800	*7700 *16,800					
4.5 m 15.0 ft	kg lb			*11 700	*11 700	*9400 *20,300	*9400 *20,300	*8200 *17,900	7700 16,600	*7500	5800	*6500 *14,200	5700 12,500	9.12 29.85
3.0 m 10.0 ft	kg lb			*14 800 *31,700	*14 800 *31,700	*10 800 *23,400	10 200 22,100	*9000 *19,400	7400 16,000	*7900 *17,300	5600 12,200	*6700 *14,700	5300 11,600	9.40 30.83
1.5 m 5.0 ft	kg lb			*17 000 *36,600	14 500 31,200	*12 100 *26,200	9700 20,900	*9700 *21,000	7100 15,300	*8300 *17,900	5500 11,800	*7100 *15,700	5100 11,300	9.44 30.96
Ground Line	kg lb			*17 800 *38,400	14 000 30,200	*12 900 *27,900	9400 20,100	*10 200 *22,000	6900 14,900	*8400 *18,200	5400 11,600	*7900 *17,400	5200 11,400	9.23 30.27
-1.5 m -5.0 ft	kg lb	*12 800 *29,000	*12 800 *29,000	*17 400 *37,700	14 000 30,000	*13 000 *28,100	9200 19,800	*10 200 *22,000	6800 14,600					
-3.0 m -10.0 ft	kg lb	*20 300 *46,000	*20 300 *46,000	*16 100 *34,900	14 100 30,300	*12 300 *26,500	9200 19,900	*9500 *20,300	6800 14,800					
-4.5 m -15.0 ft	kg lb	*18 100 *39,000	*18 100 *39,000	*13 700 *29,300	*13 700 *29,300	*10 300 *22,000	9500 20,500							

\* Indicates that the load is limited by hydraulic capacity rather than tipping capacity. Lift capacity ratings are based on SAE standard 2417. Rated loads are at 87% of hydraulic lifting capacity or 75% of tipping capacity over front and side.

Lift Point is at stick end pin.

**M322D MH Range Diagram**

- Cat Material Handling Boom and MH Stick

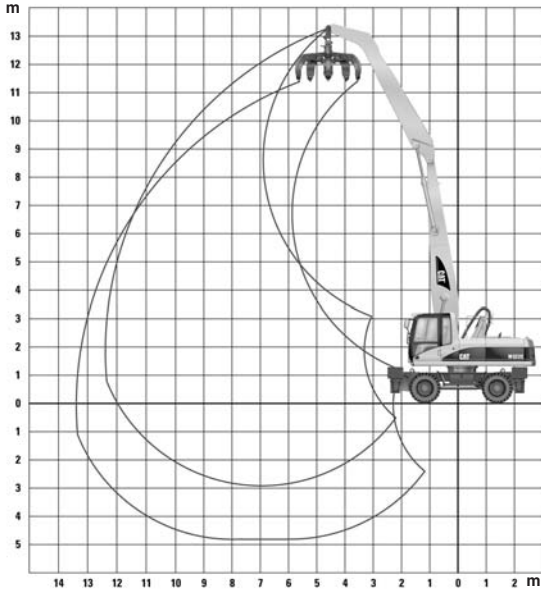

Model	M318D MH		M322D MH			
	m	ft	m	ft	m	ft
Boom	6.2	20'3"	6.8	22'3"	6.8	22'3"
Stick	4.9	16'1"	4.9	16'1"	5.9	19'4"
Maximum Horizontal Reach	11.0	36'1"	11.5	37'7"	12.5	41'0"
Maximum Vertical Pin Height	12.1	39'7"	12.5	41'0"	13.3	43'6"

**Lifting Capacities**

Equipped with Cat material handling arrangement. Capacities are measured at the bare stick tip.

**Capacities are based on level machine equipped as follows:**

- Total machine weight including base machine, material handling front, cab riser, heavy duty axles, two sets of outriggers, lubricants, full fuel tank and operator.  
M318D MH — 21 100-23 400 kg (46,517-51,588 lb)  
M322D MH — 23 500-25 700 kg (51,809-56,659 lb)

**M322D MH Range Diagram**



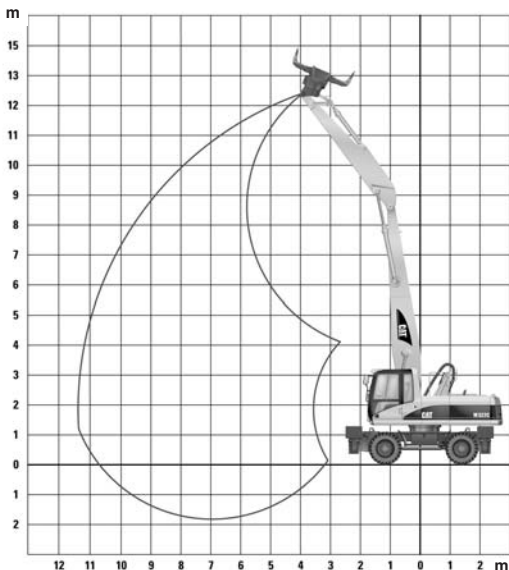











- Cat Material Handling Boom and Straight Stick



Model	M318D MH		M322D MH	
	m	ft	m	ft
Boom	6.2	20'3"	6.8	22'3"
Stick	4.2	13'8"	4.8	15'7"
Maximum Horizontal Reach	10.3	33'8"	11.4	37'4"
Maximum Vertical Pin Height	11.5	37'7"	12.4	40'7"













**M318D MH**

- 6.2 m (20'3") Straight MH Boom ● 4.9 m (16'1") MH Stick
- Front and Rear Stabilizers and Standard Tires ● No Work Tool ● All weights are in metric tons

Height**	Undercarriage configuration	3.0 m		4.5 m		6.0 m		7.5 m		9.0 m		10.5 m				m	
																	
10.5 m	All stabilizers up All stabilizers down					5.75 6.50*	4.35 6.50*										
9.0 m	All stabilizers up All stabilizers down					5.85 7.85*	4.45 7.85*	4.10 6.30*	3.10 6.30*								
7.5 m	All stabilizers up All stabilizers down					5.85 8.20*	4.45 8.20*	4.10 7.15*	3.15 6.40	3.05 5.50*	2.30 4.75			2.80 4.45*	2.10 4.40	9.42	
6.0 m	All stabilizers up All stabilizers down					5.75 8.45*	4.35 8.45*	4.05 7.25*	3.10 6.35	3.05 5.85	2.30 4.75			2.45 4.30*	1.85 3.90	10.18	
4.5 m	All stabilizers up All stabilizers down			8.75 11.20*	6.45 11.20*	5.55 8.95*	4.15 8.95*	3.95 7.45*	2.95 6.25	3.00 5.80	2.25 4.70	2.35 4.55	1.70 3.70	2.25 4.35*	1.65 3.60	10.68	
3.0 m	All stabilizers up All stabilizers down	16.20 18.65*	10.95 18.65*	8.15 12.45*	5.90 12.45*	5.25 9.45*	3.90 8.60	3.80 7.55	2.85 6.05	2.90 5.70	2.15 4.60	2.30 4.50	1.70 3.65	2.15 4.20	1.55 3.45	10.94	
1.5 m	All stabilizers up All stabilizers down			7.55 13.10*	5.35 13.10*	5.00 9.65*	3.65 8.30	3.65 7.35	2.70 5.90	2.80 5.60	2.05 4.50	2.25 4.45	1.65 3.60	2.10 4.15	1.55 3.35	11.00	
0 m	All stabilizers up All stabilizers down	3.50* 3.50*	3.50* 3.50*	7.10 12.20*	4.95 12.20*	4.75 9.30*	3.40 8.00	3.50 7.20	2.55 5.75	2.75 5.50	2.00 4.45	2.20 4.10*	1.60 3.55				
-1.5 m	All stabilizers up All stabilizers down			6.90 9.60*	4.80 9.60*	4.60 8.10*	3.30 7.85	3.40 6.30*	2.45 5.65	2.70 4.75*	1.95 4.35						

**M318D MH Heavy Lift**

- 6.2 m (20'3") Straight MH Boom ● 4.2 m (13'8") Straight Stick
- Front and Rear Stabilizers and Standard Tires ● No Work Tool ● All weights are in metric tons

Height**	Undercarriage configuration	3.0 m		4.5 m		6.0 m		7.5 m		9.0 m				m			
																	
10.5 m	All stabilizers up All stabilizers down			8.40* 8.40*	6.55 8.40*												
9.0 m	All stabilizers up All stabilizers down					5.65 8.35*	4.25 8.35*										
7.5 m	All stabilizers up All stabilizers down					5.65 8.60*	4.30 8.60*	3.95 7.35*	2.95 6.25				3.10 5.20*	2.30 4.90	8.64		
6.0 m	All stabilizers up All stabilizers down			8.85 10.90*	6.55 10.90*	5.55 8.80*	4.20 8.80*	3.90 7.40*	2.95 6.20	2.90 5.70	2.15 4.60	2.65 5.05*	1.95 4.25	9.46			
4.5 m	All stabilizers up All stabilizers down	14.80* 14.80*	11.75 14.80*	8.40 11.85*	6.15 11.85*	5.35 9.20*	4.00 8.75	3.80 7.50*	2.80 6.10	2.85 5.65	2.10 4.55	2.40 4.75	1.75 3.85	10.00			
3.0 m	All stabilizers up All stabilizers down			7.80 12.85*	5.60 12.85*	5.10 9.55*	3.70 8.40	3.65 7.40	2.70 5.90	2.80 5.55	2.05 4.50	2.25 4.55	1.65 3.65	10.28			
1.5 m	All stabilizers up All stabilizers down			7.25 12.90*	5.10 12.90*	4.80 9.50*	3.45 8.10	3.50 7.25	2.55 5.75	2.70 5.50	1.95 4.40	2.20 4.30*	1.60 3.60	10.34			
0 m	All stabilizers up All stabilizers down			6.90 9.65*	4.80 9.65*	4.60 8.80*	3.30 7.85	3.40 6.80*	2.45 5.65	2.65 5.15*	1.90 4.35						

\*Limited by hydraulic rather than tipping load.

\*\*Height of stick pin.



Load Radius Over Front



Load Radius Over Side



















Load at Maximum Reach

The above loads are in compliance with hydraulic excavator lift capacity ratings standard ISO 10567. They do not exceed 87% of hydraulic lifting capacity or 75% of tipping capacity.

Weight of all lifting accessories must be deducted from the above lifting capacities.













**M322D MH**

- 6.8 m (22'3") Straight MH Boom ● 5.9 m (19'4") MH Stick
- 3900 kg (8600 lb) Counterweight ● No Work Tool ● All weights are in metric tons

Height**	Undercarriage configuration	3.0 m		4.5 m		6.0 m		7.5 m		9.0 m		10.5 m		12.0 m				m	
																			
12.0 m	All stabilizers up All stabilizers down					7.00 7.45*	5.40 7.45*												
10.5 m	All stabilizers up All stabilizers down							5.00 7.25*	3.90 7.25*										
9.0 m	All stabilizers up All stabilizers down							5.10 7.50*	3.95 7.50*	3.75 6.75*	2.90 5.70								
7.5 m	All stabilizers up All stabilizers down							5.05 7.55*	3.95 7.55*	3.75 6.70*	2.90 5.70	2.85 5.35	2.20 4.40			2.60 4.40*	1.95 4.00		11.11
6.0 m	All stabilizers up All stabilizers down							4.95 7.75*	3.85 7.75*	3.70 6.80*	2.85 5.60	2.85 5.30	2.15 4.40			2.30 4.35*	1.75 3.60		11.76
4.5 m	All stabilizers up All stabilizers down					6.80 9.55*	5.20 9.55*	4.80 8.05*	3.70 7.35	3.60 6.70	2.75 5.50	2.80 5.25	2.10 4.30	2.20 4.25	1.65 3.50	2.15 4.15	1.60 3.40		12.20
3.0 m	All stabilizers up All stabilizers down			9.95 13.45*	7.40 13.45*	6.40 10.30*	4.85 10.15	4.55 8.40*	3.45 7.10	3.45 6.55	2.60 5.35	2.70 5.15	2.05 4.25	2.20 4.20	1.60 3.45	2.05 4.00	1.50 3.25		12.43
1.5 m	All stabilizers up All stabilizers down			9.05 14.75*	6.60 14.75*	5.95 10.85*	4.45 9.65	4.30 8.50	3.25 6.85	3.30 6.40	2.50 5.20	2.65 5.10	1.95 4.15	2.15 4.15	1.55 3.40	2.00 3.90	1.45 3.20		12.48
0 m	All stabilizers up All stabilizers down	4.05* 4.05*	4.05* 4.05*	8.35 14.75*	5.95 14.75*	5.60 10.85*	4.10 9.25	4.10 8.25	3.05 6.60	3.20 3.25	2.35 5.05	2.50 5.00	1.90 4.05	2.10 4.10*	1.55 3.35				
-1.5 m	All stabilizers up All stabilizers down			8.00 10.45*	5.60 10.45*	5.35 10.05*	3.85 8.95	3.95 7.85*	2.90 6.45	3.10 6.15	2.25 4.95	2.50 4.80*	1.85 4.00						

**M322D MH Heavy Lift**

- 6.8 m (22'3") Straight MH Boom ● 4.9 m (16'1") Straight Stick
- 3900 kg (8600 lb) Counterweight ● No Work Tool ● All weights are in metric tons

Height**	Undercarriage configuration	4.5 m		6.0 m		7.5 m		9.0 m		10.5 m				m					
																			
10.5 m	All stabilizers up All stabilizers down			6.95 9.20*	5.35 9.20*	4.80 9.35*	3.70 6.35												
9.0 m	All stabilizers up All stabilizers down			7.00 9.30*	5.45 9.30*	5.90 8.10*	3.80 7.50												
7.5 m	All stabilizers up All stabilizers down			7.00 9.40*	5.40 9.40*	4.90 8.10*	3.80 7.50	3.65 6.80	2.80 5.55					3.05 5.45*	2.30 4.65				10.02
6.0 m	All stabilizers up All stabilizers down			6.80 9.75*	5.25 9.75*	4.85 8.25*	3.70 7.40	3.65 6.75	2.80 5.55	2.80 5.25	2.15 4.30	2.70 5.05	2.10 4.15	2.50 5.05	1.85 4.15				10.74
4.5 m	All stabilizers up All stabilizers down	10.25 13.20*	7.65 13.20*	6.55 10.30*	5.00 10.30	4.65 8.50*	3.60 7.20	3.55 6.65	2.70 5.45	2.70 5.20	2.80 4.30	2.10 4.30	2.10 4.70	2.50 4.70	1.85 3.85				11.22
3.0 m	All stabilizers up All stabilizers down	9.45 14.55*	7.00 14.55*	6.20 10.90*	4.65 9.90	4.50 8.65	3.40 7.00	3.45 6.50	2.60 5.30	2.75 5.15	2.05 4.25	2.40 4.50	2.15 4.45	2.40 4.50	1.75 3.70				11.47
1.5 m	All stabilizers up All stabilizers down	8.75 15.10*	6.30 15.10*	5.80 11.10*	4.30 9.50	4.30 8.45	3.20 6.80	3.30 6.40	2.50 5.20	2.65 5.10	2.00 4.15	2.35 4.45	2.00 4.15	2.35 4.45	1.75 3.65				11.52
0 m	All stabilizers up All stabilizers down	8.25 10.25*	5.90 10.25*	5.55 10.60*	4.05 9.20	4.10 8.25	6.05 6.60	3.25 6.30	2.40 5.10	2.60 5.05*	2.10 4.10	1.95							
-1.5 m	All stabilizers up All stabilizers down			5.40 9.20*	3.95 9.00	4.00 7.25*	2.95 6.50												

\*Limited by hydraulic rather than tipping load.

\*\*Height of stick pin.



Load Radius Over Front



Load Radius Over Side



Load at Maximum Reach

The above loads are in compliance with hydraulic excavator lift capacity ratings standard ISO 10567. They do not exceed 87% of hydraulic lifting capacity or 75% of tipping capacity.

Weight of all lifting accessories must be deducted from the above lifting capacities.

Dimensions and Weights  
Range Dimensions  
● M325D MH ● M325D LMH  
(Belgium Sourced)

**Excavators —  
Material Handling**

Model	M325D MH		M325D LMH	
Horsepower (ISO 9249 Net) (EAME)	140 kW/190 hp		140 kW/190 hp	
Horsepower (ISO 9249 Net) (NACD)	140 kW/190 hp		152 kW/204 hp	
No. of Tires	<b>8 (4 Duals)</b>		<b>4 Single</b>	
Tire Size	<b>12.00-20</b>		<b>17.00-25</b>	
Maximum Travel Speed	<b>20 km/h</b>		<b>18 km/h</b>	
Hydraulic Cab Riser Maximum Height	<b>2.6 m</b>		<b>2.6 m</b>	
Boom Length	8.85 m	8.85 m	8.85 m	8.85 m
Stick Length	6.00 m	7.42 m	6.00 m	7.42 m
Overall Weight	29.80 t	30.00 t	34.54 t	34.80 t
Maximum Horizontal Reach	14.33 m	15.65 m	14.33 m	15.65 m
Maximum Vertical Pin Height	15.98 m	17.14 m	16.60 m	17.80 m
Maximum Vertical Pin Depth	5.00 m	6.40 m	4.10 m	5.50 m
Transport Length with Boom and Stick	12.21 m	11.80 m	12.18 m	11.99 m
Transport Length with Boom (No Stick)	12.18 m	12.18 m	12.18 m	12.18 m
Transport Height with Boom and Stick	3.55 m	5.10 m	3.80 m	4.75 m
Transport Height with Boom*	<b>3.55 m</b>		<b>3.80 m</b>	
Transport Width	<b>2.95 m</b>		<b>3.02 m</b>	

\*Maximum height is at the hydraulic cab riser system.

**M325D MH Working Range**

- Maximum Reach 14.3 m (46'11") or 15.6 m (51'2")

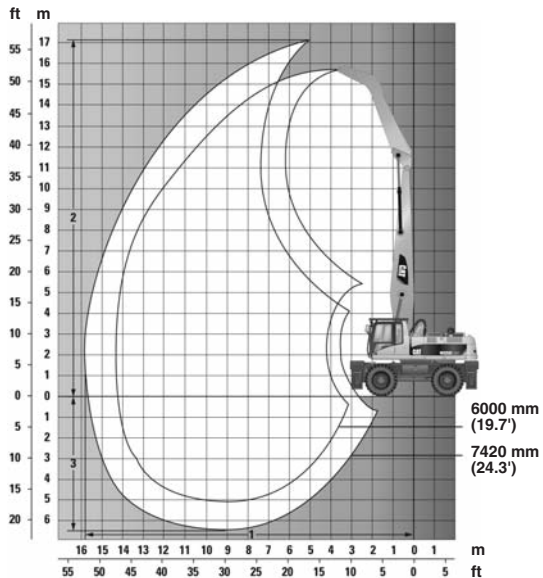

**M325D LMH Working Range**

- Maximum Reach 14.3 m (46'11") or 15.6 m (51'2")

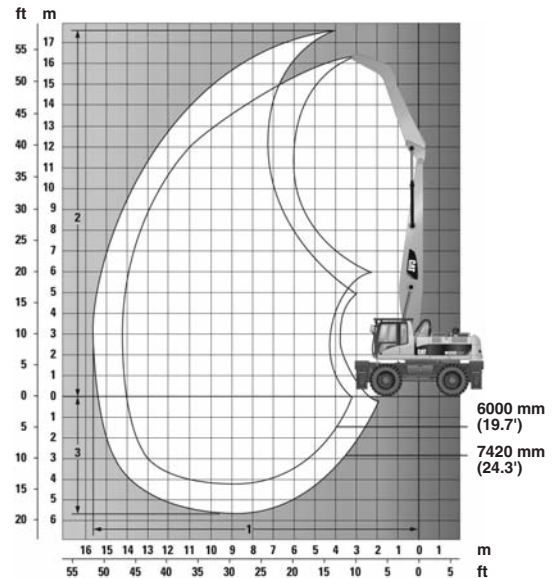



# Excavators — Material Handling



















## Lifting Capacities ● M325D MH (Belgium Sourced)

### M325D MH — Lift Capacities — 6000 mm/19'8"

With 6000 mm stick.

**BOOM** — 8850 mm    **STICK** — 6000 mm    **MAXIMUM REACH/HEIGHT/DEPTH** — 14 330 / 15 980 / 5000 mm

**Metric Units/all weights are in kg**

Reach	Undercarriage configuration	3.0 m		4.5 m		6.0 m		7.5 m		9.0 m		10.5 m		12.0 m		13.5 m				m	
																					
15.0 m	Stabilizers up					*5930	*5930											*5290	*5290	6.48	
	Stabilizers down					*6130	*6130											*5180	*5180	6.74	
13.5 m	Stabilizers up					*7330	*7330	*6210	5400									*4470	3980	8.87	
	Stabilizers down					*7400	*7400	*6340	*6340	*4500	*4500							*4420	*4420	9.04	
12.0 m	Stabilizers up							7080	5530	5210	4040	3920	2990					3910	2980	10.52	
	Stabilizers down							*7380	*7380	*6290	*6290	*4350	*4350					*4050	*4050	10.65	
10.5 m	Stabilizers up							7080	5540	5240	4070	4000	3060					3220	2420	11.75	
	Stabilizers down							*7730	*7730	*6930	*6930	*6020	*6020					*3850	*3850	11.85	
9.0 m	Stabilizers up					*9030	7770	6970	5430	5180	4010	3980	3050	3120	2340			2790	2070	12.68	
	Stabilizers down					*9070	*9070	*7880	*7880	*7000	*7000	*6300	6240	*5280	4970			*3740	*3740	12.75	
7.5 m	Stabilizers up					*9550	7460	6760	5230	5040	3880	3900	2970	3090	2310			2500	1830	13.38	
	Stabilizers down					*9610	*9610	*8200	*8200	*7180	*7180	*6380	6150	*5720	4930			*3700	*3700	13.43	
6.0 m	Stabilizers up			*12 760	10 900	9140	6970	6450	4940	4840	3690	3780	2850	3020	2240	2440	1770	2310	1670	13.88	
	Stabilizers down			*13 210	*13 210	*10 400	*10 400	*8640	*8640	*7420	*7420	*6500	6010	*5750	4860	*4830	4000	*3720	*3720	13.92	
4.5 m	Stabilizers up			13 180	9620	8460	6340	6060	4570	4610	3460	3630	2710	2930	2150	2390	1730	2180	1560	14.20	
	Stabilizers down			*15 040	*15 040	*11 290	*11 290	*9110	*9110	*7660	7410	*6610	5840	*5770	4760	4810	3950	*3780	3630	14.22	
3.0 m	Stabilizers up			*9240	8220	7730	5660	5650	4180	4350	3220	3470	2550	2820	2050	2330	1670	2100	1490	14.36	
	Stabilizers down			*8110	*8110	*11 960	*11 960	*9460	9370	*7830	7130	*6660	5670	5670	4650	4740	3890	*3900	3530	14.37	
1.5 m	Stabilizers up			*4180	*4180	7130	5100	5290	3840	4120	3000	3320	2410	2730	1960	2280	1620	2070	1460	14.36	
	Stabilizers down			*4070	*4070	*12 090	*12 090	*9540	8970	*7840	6880	*6610	5510	5560	4540	4680	3830	*4070	3500	14.35	
0.0 m	Stabilizers up			*3870	*3870	6740	4740	5020	3580	3940	2830	3190	2290	2650	1880	2240	1580	2080	1460	14.20	
	Stabilizers down			*3900	*3900	*9160	*9160	*9270	8670	*7620	6680	*6380	5380	*5350	4460	*4370	3790	*3830	3540	14.18	
-1.5 m	Stabilizers up			*4410	*4410	6550	4560	4850	3430	3820	2710	3110	2210	2600	1830	2220	1560	2140	1500	13.87	
	Stabilizers down			*4470	*4470	*8250	*8250	*8580	8500	*7110	6550	*5930	5290	*4890	4410	*3790	3770	*3470	*3470	13.84	
-3.0 m	Stabilizers up			*5170	*5170	6510	4520	4790	3360	3760	2650	3070	2170	2580	1820			2260	1590	13.37	
	Stabilizers down					*8430	*8430	*7500	*7500	*6280	*6280	*5200	*5200	*4150	*4150						
-4.5 m	Stabilizers up							4800	3380	3760	2660	3080	2180								
	Stabilizers down							*6010	*6010	*5080	*5080	*4120	*4120								

\*Rated by hydraulic capacity rather than stability capacity. Rated loads do not exceed 87% of hydraulic lifting capacity or 75% of tipping capacity.

All lifts with heavy lift on. Always refer to the appropriate Operation and Maintenance Manual for specific product information.

**M325D MH — Lift Capacities — 6000 mm/19'8"**

With 6000 mm stick.

**BOOM — 29'0"**

**STICK — 19'8"**

**MAXIMUM REACH/HEIGHT/DEPTH — 47'0" / 52'5" / 16'5"**

English Units/all weights are in lbs

Undercarriage configuration	10.0 ft		15.0 ft		20.0 ft		25.0 ft		30.0 ft		35.0 ft		40.0 ft		45.0 ft		ft		
	Stabilizers up	Stabilizers down	Stabilizers up	Stabilizers down	Stabilizers up	Stabilizers down	Stabilizers up	Stabilizers down	Stabilizers up	Stabilizers down	Stabilizers up	Stabilizers down	Stabilizers up	Stabilizers down	Stabilizers up	Stabilizers down	ft	ft	ft
50.0 ft			*15,610	*15,610													*12,170	*12,170	19.59
Stabilizers down					*12,390	*12,390											*11,880	*11,880	20.54
45.0 ft					*15,720	*15,720	*12,920	11,510									*10,030	9260	28.18
Stabilizers down					*15,920	*15,920	*13,250	*13,250									*9920	*9920	28.77
40.0 ft					*17,370	17,020	15,170	11,860	11,130	8620							8890	6770	33.92
Stabilizers down					*17,510	*17,510	*15,870	*15,870	*13,180	*13,180							*9020	*9020	34.35
35.0 ft							15,230	11,910	11,240	8730	8550	6550					7230	5450	38.16
Stabilizers down							*16,870	*16,870	*15,120	*15,120	*12,480	*12,480					*8530	*8530	38.48
30.0 ft					*19,640	16,760	15,010	11,710	11,130	8620	8550	6530	6660	4980			6240	4630	41.37
Stabilizers down					*19,710	*19,710	*17,150	*17,150	*15,230	*15,230	*13,740	13,400	*10,580	*10,580			*8270	*8270	41.60
25.0 ft					*20,720	16,120	14,570	11,290	10,850	8360	8400	6370	6610	4940			5560	4080	43.73
Stabilizers down					*20,830	*20,830	*17,810	*17,810	*15,610	*15,610	*13,870	13,230	*12,430	10,600			*8160	*8160	43.93
20.0 ft			*27,490	23,570	19,750	15,080	13,910	10,670	10,450	7960	8140	6130	6480	4810	5230	3790	5120	3700	45.44
Stabilizers down			*28,510	*28,510	*22,510	*22,510	*18,740	*18,740	*16,090	*16,090	*14,110	12,940	*12,480	10,450	*9280	8600	*8180	*8180	45.57
15.0 ft			28,510	20,880	18,280	13,710	13,100	9880	9940	7470	7830	5820	6280	4630	5140	3700	4830	3440	46.56
Stabilizers down			*32,450	*32,450	*24,410	*24,410	*19,730	*19,730	*16,620	15,960	*14,330	12,590	12,460	10,230	10,340	8490	*8330	8000	46.62
10.0 ft			*23,520	17,860	16,710	12,260	12,210	9040	9390	6970	7470	5490	6090	4410	5000	3590	4630	3290	47.11
Stabilizers down			*20,420	*20,420	*25,880	*25,880	*20,500	20,190	*16,980	15,370	*14,440	12,210	12,210	10,010	10,210	8380	*8580	7780	47.15
5.0 ft			*9860	*9860	15,390	11,050	11,420	8290	8910	6480	7140	5180	5860	4210	4890	3480	4560	3220	47.11
Stabilizers down			*9590	*9590	*26,210	*26,210	*20,700	19,340	*17,000	14,820	*14,310	11,880	11,990	9790	10,100	8250	*8950	7720	47.08
0.0 ft			*8890	*8890	14,550	10,250	10,830	7740	8510	6110	6880	4940	5710	4060	4830	3400	4590	3220	46.59
Stabilizers down			*8950	*8950	*21,450	*21,450	*20,080	18,670	*16,510	14,400	*13,800	11,600	*11,530	9610	*9280	8160	*8440	7800	46.52
-5.0 ft			*10,010	*10,010	14,130	9860	10,470	7410	8220	5840	6700	4760	5600	3950	4780	3370	4720	3310	45.51
Stabilizers down			*10,140	*10,140	*19,030	*19,030	*18,610	18,300	*15,390	14,110	*12,790	11,400	*10,470	9500	*7890	*7890	*7630	*7630	45.37
-10.0 ft			*11,660	*11,660	14,020	9770	10,320	7250	8110	5730	6610	4670	5580	3920			4980	3510	43.80
Stabilizers down					*19,160	*19,160	*16,230	*16,230	*13,540	*13,540	*11,160	*11,160	*8770	*8770					
-15.0 ft							10,360	7300	8110	5730	6660	4700							
Stabilizers down							*12,920	*12,920	*10,870	*10,870	*8690	*8690							

\*Rated by hydraulic capacity rather than stability capacity. Rated loads do not exceed 87% of hydraulic lifting capacity or 75% of tipping capacity.

All lifts with heavy lift on. Always refer to the appropriate Operation and Maintenance Manual for specific product information.

# Excavators — Material Handling

## Lifting Capacities ● M325D MH (Belgium Sourced)

### M325D MH — Lift Capacities — 7420 mm/24'4"

With 7420 mm stick.

**BOOM** — 8850 mm

**STICK** — 7420 mm

**MAXIMUM REACH/HEIGHT/DEPTH** — 15 650 / 17 140 / 6400 mm

**Metric Units/all weights are in kg**

Reach	Undercarriage configuration	3.0 m		4.5 m		6.0 m		7.5 m		9.0 m		10.5 m		12.0 m		13.5 m		15.0 m				m		
		Stabilizers up	Stabilizers down	Stabilizers up	Stabilizers down	Stabilizers up	Stabilizers down	Stabilizers up	Stabilizers down	Stabilizers up	Stabilizers down	Stabilizers up	Stabilizers down	Stabilizers up	Stabilizers down	Stabilizers up	Stabilizers down	Stabilizers up	Stabilizers down	Stabilizers up	Stabilizers down			
16.5 m	Stabilizers up					*4960	*4960														*4520	*4520	6.43	
	Stabilizers down					*5120	*5120														*4410	*4410	6.73	
15.0 m	Stabilizers up							*5160	*5160	*3810	*3810										*3690	*3690	9.09	
	Stabilizers down							*5250	*5250	*3980	*3980										*3640	*3640	9.28	
13.5 m	Stabilizers up							*5900	5810	*5110	4230	*3840	3130								*3300	2870	10.92	
	Stabilizers down							*5940	*5940	*5180	*5180	*3970	*3970								*3270	*3270	11.06	
12.0 m	Stabilizers up									5500	4320	4180	3230	3220	2430						3050	2290	12.29	
	Stabilizers down									*5850	*5850	*5020	*5020	*3630	*3630						*3060	*3060	12.40	
10.5 m	Stabilizers up									5510	4320	4200	3250	3270	2480						2600	1920	13.36	
	Stabilizers down									*6280	*6280	*5740	*5740	*4690	*4690						*2940	*2940	13.44	
9.0 m	Stabilizers up							*7020	5790	5430	4250	4160	3210	3250	2470	2570	1900				2300	1670	14.18	
	Stabilizers down							*7040	*7040	*6370	*6370	*5820	*5820	*5340	5120	*4000	*4000				*2860	*2860	14.25	
7.5 m	Stabilizers up									7150	5590	5290	4110	4060	3120	3190	2410	2540	1870			2090	1490	14.81
	Stabilizers down							*7370	*7370	*6580	*6580	*5940	*5940	*5390	5060	*4820	4120				*2840	*2840	14.86	
6.0 m	Stabilizers up					*8490	7590	6830	5290	5070	3900	3920	2980	3100	2320	2490	1820	2010	1420			1930	1360	15.26
	Stabilizers down					*8650	*8650	*7840	*7840	*6860	*6860	*6100	*6100	*5470	4950	*4920	4060	*3430	3370		*2840	*2840	15.30	
4.5 m	Stabilizers up			*10 430	*10 430	9130	6950	6420	4900	4810	3650	3740	2810	2980	2200	2410	1750	1970	1390	1830	1830	1270	15.56	
	Stabilizers down			*11 040	*11 040	*10 150	*10 150	*8400	*8400	*7180	*7180	*6280	5980	*5560	4830	4850	3980	*4030	3330	*2880	*2880	*2960	15.58	
3.0 m	Stabilizers up			12 940	9390	8310	6180	5940	4450	4510	3360	3540	2620	2850	2080	2330	1660	1920	1340	1760	1760	1210	15.70	
	Stabilizers down			*14 930	*14 930	*11 120	*11 120	*8930	*8930	*7470	7310	*6430	5760	*5610	4680	4750	3890	4020	3280	*2960	*2960	*2960	15.71	
1.5 m	Stabilizers up			*9870	7950	7510	5440	5480	4010	4210	3080	3350	2430	2720	1950	2240	1580	1870	1290	1730	1180	15.70		
	Stabilizers down			*8900	*8900	*11 770	*11 770	*9280	9200	*7660	6990	*6500	5550	5570	4550	4660	3800	3970	3230	*3070	3010	15.69		
0.0 m	Stabilizers up	*2090	*2090	*5270	*5270	6890	4870	5090	3640	3960	2840	3180	2270	2600	1840	2170	1510	1830	1250	1730	1170	15.55		
	Stabilizers down	*2130	*2130	*5160	*5160	*11 850	*11 850	*9330	8770	*7650	6710	*6440	5370	5440	4420	4580	3720	*3830	3190	*3230	3030	15.53		
-1.5 m	Stabilizers up	*2620	*2620	*4740	*4740	6500	4510	4810	3380	3760	2650	3040	2130	2510	1750	2110	1450	1810	1230	1770	1200	15.26		
	Stabilizers down	*2680	*2680	*4740	*4740	*9670	*9670	*9020	8460	*7410	6500	*6200	5230	*5220	4330	*4350	3660	*3380	3160	*3190	3100	15.22		
-3.0 m	Stabilizers up	*3270	*3270	*4950	*4950	6310	4320	4650	3220	3640	2530	2950	2050	2450	1690	2080	1420				1840	1250	14.80	
	Stabilizers down	*3320	*3320	*4980	*4980	*8590	*8590	*8330	8290	*6880	6370	*5730	5130	*4760	4270	*3820	3630				*2860	*2860	14.75	
-4.5 m	Stabilizers up			*5390	*5390	6250	4270	4580	3160	3580	2470	2910	2010	2430	1670	2090	1430							
	Stabilizers down			*5440	*5440	*8550	*8550	*7230	*7230	*6030	*6030	*4990	*4990	*4030	*4030	*2990	*2990							
-6.0 m	Stabilizers up							4600	3180	3580	2480	2920	2020											
	Stabilizers down							*5730	*5730	*4810	*4810	*3900	*3900											

\*Rated by hydraulic capacity rather than stability capacity. Rated loads do not exceed 87% of hydraulic lifting capacity or 75% of tipping capacity.

All lifts with heavy lift on. Always refer to the appropriate Operation and Maintenance Manual for specific product information.

**M325D MH — Lift Capacities — 7420 mm/24'4"**

With 7420 mm stick.

**BOOM — 29'0"**

**STICK — 24'4"**

**MAXIMUM REACH/HEIGHT/DEPTH — 51'4" / 56'3" / 21'0"**

English Units/all weights are in lbs

Hand icon	Undercarriage configuration	10.0 ft		15.0 ft		20.0 ft		25.0 ft		30.0 ft		35.0 ft		40.0 ft		45.0 ft		50.0 ft		Hand icon		ft	
		Hand icon	Hand icon	Hand icon	Hand icon	Hand icon	Hand icon	Hand icon	Hand icon	Hand icon	Hand icon	Hand icon	Hand icon	Hand icon	Hand icon	Hand icon	Hand icon	Hand icon	Hand icon	Hand icon	Hand icon		Hand icon
	Stabilizers up																						
	Stabilizers down																						
	Stabilizers up																						
	Stabilizers down																						
	Stabilizers up																						
	Stabilizers down																						
	Stabilizers up																						
	Stabilizers down																						
	Stabilizers up																						
	Stabilizers down																						
	Stabilizers up																						
	Stabilizers down																						
	Stabilizers up																						
	Stabilizers down																						
	Stabilizers up																						
	Stabilizers down																						
	Stabilizers up																						
	Stabilizers down																						
	Stabilizers up																						
	Stabilizers down																						
	Stabilizers up																						
	Stabilizers down																						
	Stabilizers up																						
	Stabilizers down																						
	Stabilizers up																						
	Stabilizers down																						
	Stabilizers up																						
	Stabilizers down																						
	Stabilizers up																						
	Stabilizers down																						
	Stabilizers up																						
	Stabilizers down																						
	Stabilizers up																						
	Stabilizers down																						
	Stabilizers up																						
	Stabilizers down																						

\*Rated by hydraulic capacity rather than stability capacity. Rated loads do not exceed 87% of hydraulic lifting capacity or 75% of tipping capacity.

All lifts with heavy lift on. Always refer to the appropriate Operation and Maintenance Manual for specific product information.

# Excavators — Material Handling

## Lifting Capacities ● M325D LMH (Belgium Sourced)

### M325D LMH — Lift Capacities — 6000 mm/19'8"



















With 6000 mm stick.

**BOOM** — 8850 mm

**STICK** — 6000 mm

**MAXIMUM REACH/HEIGHT/DEPTH** — 14 330 / 16 600 / 4100 mm

**Metric Units/all weights are in kg**

Undercarriage configuration	3.0 m		4.5 m		6.0 m		7.5 m		9.0 m		10.5 m		12.0 m		13.5 m				m			
																						
16.5 m Stabilizers up																						
16.5 m Stabilizers down																				*8210	*8210	3.69
15.0 m Stabilizers up																						
15.0 m Stabilizers down																						
13.5 m Stabilizers up																						
13.5 m Stabilizers down																						
12.0 m Stabilizers up																						
12.0 m Stabilizers down																						
10.5 m Stabilizers up																						
10.5 m Stabilizers down																						
9.0 m Stabilizers up																						
9.0 m Stabilizers down																						
7.5 m Stabilizers up																						
7.5 m Stabilizers down																						
6.0 m Stabilizers up																						
6.0 m Stabilizers down																						
4.5 m Stabilizers up																						
4.5 m Stabilizers down																						
3.0 m Stabilizers up																						
3.0 m Stabilizers down																						
1.5 m Stabilizers up																						
1.5 m Stabilizers down																						
0.0 m Stabilizers up																						
0.0 m Stabilizers down																						
-1.5 m Stabilizers up																						
-1.5 m Stabilizers down																						
-3.0 m Stabilizers up																						
-3.0 m Stabilizers down																						

\*Rated by hydraulic capacity rather than stability capacity. Rated loads do not exceed 87% of hydraulic lifting capacity or 75% of tipping capacity.

All lifts with heavy lift on. Always refer to the appropriate Operation and Maintenance Manual for specific product information.

**M325D LMH — Lift Capacities — 6000 mm/19'8"**

With 6000 mm stick.

**BOOM — 29'0"**

**STICK — 19'8"**

**MAXIMUM REACH/HEIGHT/DEPTH — 47'0" / 54'6" / 13'5"**

English Units/all weights are in lbs

Reach	Undercarriage configuration	10.0 ft		15.0 ft		20.0 ft		25.0 ft		30.0 ft		35.0 ft		40.0 ft		45.0 ft		ft		
		Up	Down	Up	Down	Up	Down	Up	Down	Up	Down	Up	Down	Up	Down	Up	Down	Up	Down	ft
50.0 ft	Stabilizers up			*18,980	*18,980	*15,120												*14,090	*14,090	21.00
	Stabilizers down			*19,490	*19,490	*16,120												*13,540	*13,540	22.67
45.0 ft	Stabilizers up					*18,920	*18,920	*15,920	15,700									*11,880	*11,880	29.04
	Stabilizers down					*19,270	*19,270	*16,540	*16,540	*11,800	*11,800							*11,660	*11,660	30.09
40.0 ft	Stabilizers up					*20,700	*20,700	*18,870	16,030	15,260	11,860							*10,870	*10,760	34.51
	Stabilizers down					*20,940	*20,940	*19,250	*19,250	*16,380	*16,380	*11,200	*11,200					*10,760	*10,760	35.30
35.0 ft	Stabilizers up					*22,110	*22,110	*19,470	16,030	15,320	11,930	11,840	9130					9940	7580	38.58
	Stabilizers down					*22,180	*22,180	*19,490	*19,490	*17,510	*17,510	*15,570	*15,570					*10,250	*10,250	39.17
30.0 ft	Stabilizers up					*22,770	*22,360	*19,840	15,760	15,170	11,770	11,800	9080	9370	7120			8690	6570	41.63
	Stabilizers down					*22,950	*22,950	*19,950	*19,950	*17,730	*17,730	*15,960	*15,960	*13,430	*13,430			*10,010	*10,010	42.09
25.0 ft	Stabilizers up			*25,750	*25,750	*24,140	21,560	19,750	15,260	14,820	11,460	11,600	8910	9280	7060			7870	5910	43.93
	Stabilizers down			*26,540	*26,540	*24,450	*24,450	*20,830	*20,830	*18,210	*18,210	*16,160	*16,160	*14,460	14,400			*9940	*9940	44.26
20.0 ft	Stabilizers up	*29,010	*29,010	*33,180	31,700	*26,170	20,350	18,980	14,530	14,350	11,000	11,290	8620	9130	6900	7470	5580	7320	5450	45.54
	Stabilizers down	*33,090	*33,090	*33,950	*33,950	*26,540	*26,540	*21,980	*21,980	*18,830	*18,830	*16,470	*16,470	*14,550	14,200	*11,660	*11,660	*10,010	*10,010	45.77
15.0 ft	Stabilizers up			*37,850	28,510	25,130	18,810	18,030	13,650	13,780	10,450	10,940	8270	8910	6680	7390	5490	6370	5160	46.56
	Stabilizers down			*38,600	*38,600	*28,770	*28,770	*23,150	*23,150	*19,420	*19,420	*16,710	*16,710	*14,570	13,960	*12,590	11,660	*10,230	*10,230	46.69
10.0 ft	Stabilizers up			*22,640	*22,640	23,390	17,170	17,040	12,720	13,160	9880	10,560	7920	8660	6460	7250	5360	6770	4980	47.01
	Stabilizers down			*18,560	*18,560	*30,310	*30,310	*23,940	*23,940	*19,800	*19,800	*16,800	16,670	*14,440	13,710	*12,260	11,530	*10,580	*10,580	47.05
5.0 ft	Stabilizers up			*11,620	*11,620	21,980	15,870	16,180	11,930	12,630	9370	10,210	7580	8440	6240	7120	5230	6700	4920	46.95
	Stabilizers down			*11,220	*11,220	*30,360	*30,360	*24,010	*24,010	*19,710	*19,710	*16,580	16,290	*14,040	13,470	*11,640	11,400	*10,560	*10,560	46.88
0.0 ft	Stabilizers up			*11,110	*11,110	21,098	15,080	15,570	11,350	12,210	8970	9920	7300	8270	6090	7030	5160	6770	4960	46.33
	Stabilizers down			*11,310	*11,310	*25,110	*25,110	*23,100	*23,100	*19,000	*19,000	*15,870	*15,870	*13,230	*13,230	*10,560	*10,560	*9790	*9790	46.16
-5.0 ft	Stabilizers up			*12,660	*12,660	20,680	14,710	15,210	11,000	11,930	8710	9740	7120	8160	5980	7010	5140	6990	5120	45.14
	Stabilizers down			*13,010	*13,010	*23,300	*23,300	*21,160	*21,160	*17,550	*17,550	*14,570	*14,570	*11,860	*11,860			*8820	*8820	44.88
-10.0 ft	Stabilizers up					20,610	14,640	15,080	10,890	11,820	8600	9660	7060	8160	5950					
	Stabilizers down					*21,297	*21,300	*18,170	*18,170	*15,210	*15,210	*12,480	*12,480	*9680	*9680					

\*Rated by hydraulic capacity rather than stability capacity. Rated loads do not exceed 87% of hydraulic lifting capacity or 75% of tipping capacity.

All lifts with heavy lift on. Always refer to the appropriate Operation and Maintenance Manual for specific product information.

# Excavators — Material Handling

## Lifting Capacities ● M325D LMH (Belgium Sourced)

### M325D LMH — Lift Capacities — 7420 mm/24'4"



















With 7420 mm stick.

**BOOM** — 8850 mm

**STICK** — 7420 mm

**MAXIMUM REACH/HEIGHT/DEPTH** — 15 650 / 17 800 / 5500 mm

**Metric Units/all weights are in kg**

Reach	Undercarriage configuration	3.0 m		4.5 m		6.0 m		7.5 m		9.0 m		10.5 m		12.0 m		13.5 m		15.0 m				m		
																								
16.5 m	Stabilizers up					*6170	*6170														*5230	*5230	6.86	
	Stabilizers down					*6440	*6440															*5020	*5020	7.37
15.0 m	Stabilizers up							*6260	*6260	*4850	*4850											*4370	*4370	9.36
	Stabilizers down							*6440	*6440	*5170	*5170											*4280	*4280	9.70
13.5 m	Stabilizers up							*7040	*7040	*6180	*6180	*4800	*4360									*3950	*3900	11.11
	Stabilizers down							*7140	*7140	*6330	*6330	*5060	*5060									*3900	*3900	11.36
12.0 m	Stabilizers up							*7530	*7530	*6940	*6940	*5830	*5720	*4450	*4400	3440						*3710	*3190	12.43
	Stabilizers down							*7600	*7600	*7050	*7050	*6150	*6150	*4650	*4650							*3680	*3680	12.63
10.5 m	Stabilizers up							*7920	*7920	*7250	*7250	*5810	*5730	*4460	*4530	3480						*3570	*2740	13.46
	Stabilizers down							*7940	*7940	*7260	*7260	*6680	*6680	*5770	*5770			*3760	*3760			*3550	*3550	13.61
9.0 m	Stabilizers up							*8120	*7710	*7320	*7320	*5670	*5670	*4400	*4500	3460	3630	2740				*3260	*2430	14.25
	Stabilizers down							*8180	*8180	*7410	*7410	*6760	*6760	*6200	*6200	*4980	*4980					*3480	*3480	14.37
7.5 m	Stabilizers up							*8520	*7470	*7150	*7150	*5560	*5550	*4290	*4430	3380	3590	2700				*2990	*2210	14.85
	Stabilizers down					*9030	*9030	*8610	*8610	*7670	*7670	*6920	*6920	*6280	*6280	*5710	5610					*3460	*3460	14.94
6.0 m	Stabilizers up					*10 340	*10 100	*9090	7110	6900	5320	5380	4130	4320	3280	3530	2640	2910	2140			*2810	*2050	15.28
	Stabilizers down					*10 790	*10 790	*9200	*9200	*8030	*8030	*7120	*7120	*6380	*6380	*5730	5530	*4250	*4250			*3490	*3490	15.33
4.5 m	Stabilizers up			*13 670	*13 670	*11 800	9350	8730	6660	6590	5030	5180	3930	4190	3150	3440	2560	2870	2090	2680		1950	15.55	
	Stabilizers down			*15 510	*15 510	*12 010	*12 010	*9880	*9880	*8410	*8410	*7330	*7330	*6480	*6480	*5750	5440	*4900	4600	*3550	*3550	*3550	15.58	
3.0 m	Stabilizers up			*17 420	12 860	11 440	8480	8200	6160	6260	4710	4960	3720	4040	3010	3350	2470	2810	2040	2610		1880	15.67	
	Stabilizers down			*17 740	*17 740	*13 120	*13 120	*10 470	*10 470	*8740	*8740	*7500	*7500	*6530	6380	*5720	5340	*4930	4540	*3660	*3660	*3660	15.67	
1.5 m	Stabilizers up			*10 150	*10 150	10 560	7680	7680	5680	5930	4400	4750	3520	3900	2870	3250	2380	2760	1990	2580		1850	15.64	
	Stabilizers down			*8790	*8790	*13 750	*13 750	*10 830	*10 830	*8920	*8920	*7560	*7560	*6500	6230	*5610	5240	*4730	4480	*3810	*3810	*3810	15.62	
0.0 m	Stabilizers up	*2690	*2690	*6270	*6270	9900	7070	7270	5290	5660	4140	4560	3340	3770	2750	3170	2300	2710	1940	2590		1850	15.47	
	Stabilizers down	*2790	*2790	*6090	*6090	*13 690	*13 690	*10 810	*10 810	*8870	*8870	*7450	*7390	*6340	6100	*5370	5160	*4380	*4380	*4020	*4020	*4020	15.43	
-1.5 m	Stabilizers up	*3390	*3390	*5860	*5860	9500	6700	6980	5010	5450	3950	4420	3200	3670	2660	3110	2240	2690	1920	2650		1900	15.15	
	Stabilizers down	*3520	*3520	*5890	*5890	*11 360	*11 360	*10 360	*10 360	*8520	*8520	*7120	*7120	*5990	*5990	*4960	*4960	*3790	*3790	*3710	*3710	*3710	15.08	
-3.0 m	Stabilizers up			*6190	*6190	9300	6530	6810	4860	5320	3820	4320	3110	3610	2600	3080	2210				2770	1990	14.66	
	Stabilizers down			*6280	*6280	*10 480	*10 480	*9450	*9450	*7830	*7830	*6520	*6520	*5390	*5390	*4280	*4280				*3320	*3320	14.56	
-4.5 m	Stabilizers up					*9260	*6490	*6750	4800	5260	3770	4290	3080	3600	2580									
	Stabilizers down					*9640	*9640	*8080	*8080	*6750	*6750	*5580	*5580	*4470	*4470									

\*Rated by hydraulic capacity rather than stability capacity. Rated loads do not exceed 87% of hydraulic lifting capacity or 75% of tipping capacity.

All lifts with heavy lift on. Always refer to the appropriate Operation and Maintenance Manual for specific product information.

**M325D LMH — Lift Capacities — 7420 mm/24'4"**

With 7420 mm stick.

**BOOM — 29'0"**

**STICK — 24'4"**

**MAXIMUM REACH/HEIGHT/DEPTH — 51'4" / 58'5" / 18'1"**

English Units/all weights are in lbs

Hand icon	Undercarriage configuration	10.0 ft		15.0 ft		20.0 ft		25.0 ft		30.0 ft		35.0 ft		40.0 ft		45.0 ft		50.0 ft		Hand icon		ft	
		Hand icon	Hand icon	Hand icon	Hand icon	Hand icon	Hand icon	Hand icon	Hand icon	Hand icon	Hand icon	Hand icon	Hand icon	Hand icon	Hand icon	Hand icon	Hand icon	Hand icon	Hand icon	Hand icon	Hand icon		Hand icon
	55.0 ft Stabilizers up																						
	55.0 ft Stabilizers down					*12,570	*12,570																
	50.0 ft Stabilizers up					*13,380	*13,380																
	50.0 ft Stabilizers down					*15,540	*15,540																
	45.0 ft Stabilizers up							*13,180	*13,180														
	45.0 ft Stabilizers down							*13,650	*13,650	*10,360	*10,360												
	40.0 ft Stabilizers up							*15,210	*15,210	*13,070	12,300												
	40.0 ft Stabilizers down							*15,430	*15,430	*13,450	*13,450	*10,230	*10,230										
	35.0 ft Stabilizers up							*16,380	*16,380	*14,950	12,500	12,260	9520		*8580	7300							
	35.0 ft Stabilizers down							*16,560	*16,560	*15,210	*15,210	*12,990	*12,990	*9240	*9240								
	30.0 ft Stabilizers up							*17,310	16,840	*15,830	12,500	12,300	9570	9700	7430								
	30.0 ft Stabilizers down							*17,350	*17,350	*15,850	*15,850	*14,600	*14,600	*12,040	*12,040								
	25.0 ft Stabilizers up							*17,700	16,600	15,760	12,320	12,190	9460	9660	7410	7760	5840						
	25.0 ft Stabilizers down							*17,810	*17,810	*16,140	*16,140	*14,730	*14,730	*13,510	*13,510	*10,050	*10,050						
	20.0 ft Stabilizers up							*18,540	16,090	15,390	11,970	11,950	9220	9520	7250	7690	5780						
	20.0 ft Stabilizers down							*19,820	*19,820	*18,720	*18,720	*16,690	*16,690	*15,060	*15,060	*13,650	*13,650	*12,210	12,040				
	15.0 ft Stabilizers up							*22,530	21,800	*19,730	15,340	14,860	11,460	11,600	8890	9280	7030	7580	5670	6220	4560	6220	4540
	15.0 ft Stabilizers down							*23,410	*23,410	*19,970	*19,970	*17,440	*17,440	*15,480	*15,480	*13,870	*13,870	*12,430	11,910	*8070	*8070	*7670	*7670
	10.0 ft Stabilizers up							*29,320	25,550	20,220	18,830	14,370	14,200	10,850	11,160	8470	9020	6770	7410	5490	6150	4480	5930
	10.0 ft Stabilizers down							*33,440	*33,440	*25,990	*25,990	*21,410	*21,410	*18,250	*18,250	*15,920	*15,920	*14,070	*14,070	*12,460	11,710	*9590	*9590
	5.0 ft Stabilizers up							*24,300	24,300	22,770	16,600	16,580	12,260	12,790	9500	10,230	7580	8400	6170	7010	5090	5930	4260
	5.0 ft Stabilizers down							*20,830	*20,830	*29,810	*29,810	*23,480	*23,480	*19,340	*19,340	*16,380	16,340	*14,070	13,430	*12,100	11,290	*10,080	9660
	0.0 ft Stabilizers up							*6110	*6110	*14,420	*14,420	21,340	15,280	15,680	11,420	12,190	8930	9830	7210	8110	5910	6830	4940
	0.0 ft Stabilizers down							*6310	*6310	*13,980	*13,980	29,700	29,700	*23,440	*23,440	*19,200	*19,200	16,140	15,920	*13,690	13,160	*11,550	11,110
	-5.0 ft Stabilizers up							*7610	*7610	*13,320	*13,320	20,460	14,460	15,040	10,830	11,750	8510	9520	6900	7920	5710	6700	4830
	-5.0 ft Stabilizers down							*7920	*7920	*13,360	*13,360	26,290	26,290	*22,440	*22,440	18,430	18,430	*15,390	*15,390	*12,900	*12,900	*10,580	*10,580
	-10.0 ft Stabilizers up							*13,980	*13,980	20,040	14,090	14,680	10,470	11,460	8250	9330	6720	7780	5600	6660	4760		6130
	-10.0 ft Stabilizers down							*14,180	*14,180	*24,010	*24,010	20,440	20,440	*16,890	*16,890	*14,020	*14,020	*11,530	*11,530	*9000	*9000		
	-15.0 ft Stabilizers up									19,950	14,000	14,550	10,360	11,350	8140	9260	6640	7760	5580				
	-15.0 ft Stabilizers down									*20,790	*20,790	*17,390	*17,390	*14,480	*14,480	*11,910	*11,910	*9390	*9390				

\*Rated by hydraulic capacity rather than stability capacity. Rated loads do not exceed 87% of hydraulic lifting capacity or 75% of tipping capacity.

All lifts with heavy lift on. Always refer to the appropriate Operation and Maintenance Manual for specific product information.



**325D MH Range Diagrams**

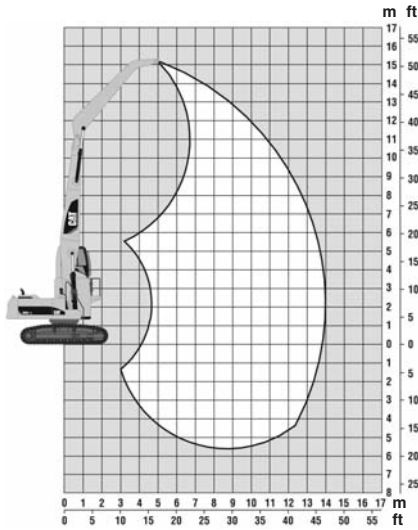

Maximum Reach 14.1 m (46'4")

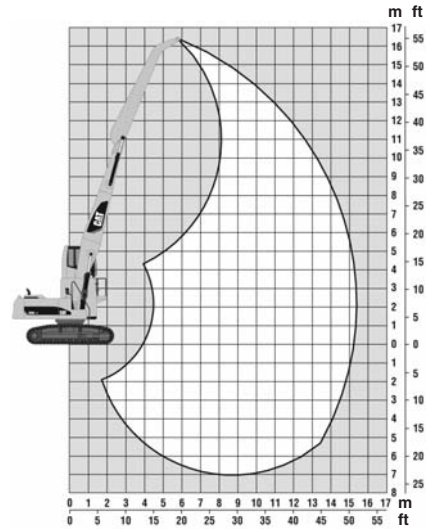

Maximum Reach 15.5 m (50'11")

**325D MH Specifications**



**Model**

**325D MH**

	Long Stick		Short Stick	
Overall Weight	35.5 t	<b>78,200 lb</b>	35.2 t	<b>77,600 lb</b>
Horsepower (Net)	152 kW	<b>204 hp</b>	152 kW	<b>204 hp</b>
Boom Length	8.85 m	<b>29'0"</b>	8.85 m	<b>29'0"</b>
Stick Length	7.42 m	<b>24'3"</b>	6.00 m	<b>19'8"</b>
Maximum Horizontal Reach	15.5 m	<b>50'11"</b>	14.1 m	<b>46'4"</b>
Maximum Vertical Pin Height	16.4 m	<b>53'10"</b>	15.2 m	<b>49'11"</b>
Maximum Depth	7.07 m	<b>23'2"</b>	5.66 m	<b>18'6"</b>

Cab Height (with cab in raised position): 6050 mm (19'10").

Cab Height (with cab in lower position): 5374 mm (17'8").

**Lift Capacities**

325D MH-Short Stick

**BOOM** — 8.85 m (29'0")  
**STICK** — 6.0 m (19'8")

**MAX REACH** — 14.1 m (46'4")  
**MAX HEIGHT** — 15.2 m (49'11.4")

**MAX DEPTH** — 5.66 m (18'6.8")

Lift Point Height	3.0 m/10.0 ft		4.5 m/15.0 ft		6.0 m/20.0 ft		7.5 m/25.0 ft		9.0 m/30.0 ft		10.5 m/35.0 ft		12.0 m/40.0 ft		13.5 m/45.0 ft		Maximum Reach				
	Over Front	Over Side	Over Front	Over Side	Over Front	Over Side	Over Front	Over Side	Over Front	Over Side	Over Front	Over Side	Over Front	Over Side	Over Front	Over Side	Over Front	Over Side	m	ft	
15.0 m 50.0 ft	kg lb		*6010 *12,740	*6010 *12,740	*5500 *12,190	*5500 *12,190												*5500 *12,740	*5500 *12,740	5.61 16.48	
13.5 m 45.0 ft	kg lb				*7040 *15,230	*7040 *15,230	*5740 *10,280	*5740 *10,280	*4580 *9,290	*4580 *9,290								*4600 *10,330	*4600 *10,330	8.29 26.16	
12.0 m 40.0 ft	kg lb				*7970 *17,300	*7970 *17,300	*7390 *15,680	*7390 *15,680	*5860 *9,290	*5860 *9,290	*4170 *4170							*4200 *9,340	*4200 *9,340	10.05 32.34	
10.5 m 35.0 ft	kg lb				*18,580	*18,580	*7990 *17,460	*7990 *17,460	*7240 *15,650	*7240 *15,650	*5560 *8,780	*5560 *8,780	*3970 *3970					*3990 *8,830	*3990 *8,830	11.35 36.81	
9.0 m 30.0 ft	kg lb				*8860 *19,390	*8860 *19,390	*8130 *17,720	*8130 *17,720	*7300 *15,910	*7300 *15,700	6440 13,840	5630 12,090	*3870 *8,540	*3870 *8,540				*3890 *8,590	*3890 *8,590	12.33 40.17	
7.5 m 25.0 ft	kg lb				*9810 *21,290	*9810 *21,290	*8470 *18,410	*8470 *18,410	*7490 *16,300	7140 15,370	6350 13,650	5540 11,900	5070 10,887	4400 9,450	*3840 *8,470	3770 8,380		*3860 *8,520	3780 8,390	13.06 42.67	
6.0 m 20.0 ft	kg lb		*13,360 *28,840	*13,360 *28,840	*10,680 *23,120	*10,680 *23,120	*8970 *19,460	*8970 *19,460	*7770 *16,890	6900 14,860	6190 13,330	5390 11,590	4980 10,710	4320 9,280	*3870 *8,530	3470 7,690		*3900 *8,590	3480 7,700	13.58 44.47	
4.5 m 15.0 ft	kg lb		*15,480 *33,370	*15,480 *33,370	*11,730 *25,370	*11,730 *25,370	*9540 *20,680	8730 18,830	7620 16,420	6600 14,230	6000 12,930	5200 11,200	4870 10,470	4200 9,040	3810 8,420	3270 7,230		3810 8,430	3280 7,240	13.93 45.64	
3.0 m 10.0 ft	kg lb		*16,690 *36,790	*16,690 *36,790	*12,670 *27,420	11,400 24,610	9560 20,620	8210 17,710	7290 15,730	6290 13,560	5800 12,490	5000 10,780	4740 10,200	4080 8,780	3680 8,120	3150 6,950		3680 8,120	3150 6,960	14.1 46.25	
1.5 m 5.0 ft	kg lb		*7850 *17,470	*7850 *17,470	12,590 27,130	10,600 22,880	9080 19,570	7740 16,700	6990 15,070	5990 12,930	5600 12,080	4810 10,370	4610 9,940	3960 8,520	3620 7,990	3100 6,830		3630 7,990	3100 6,830	14.11 46.3	
Ground Line	kg lb		*5010 *11,050	*5010 *11,050	12,040 25,920	10,080 21,730	8710 18,780	7390 15,930	6750 14,550	5750 12,410	5440 11,730	4650 10,030	4510 9,720	3850 8,310	3640 8,020	3100 6,840		3640 8,030	3110 6,850	13.96 45.8	
-1.5 m -5.0 ft	kg lb	*4050 *8,980	*4050 *8,980	*6080 *13,760	*6080 *13,760	*10,770 *24,760	9820 21,150	8480 18,280	7170 15,450	6580 14,190	5590 12,060	5330 11,490	4540 9,790	4440 9,570	3780 8,160	3730 8,240	3180 7,020		3740 8,240	3190 7,030	13.64 44.73
-3.0 m -10.0 ft	kg lb			*5740 *12,810	*5740 *12,810	*10,450 *23,100	9750 20,980	8380 *18,060	7070 15,240	6490 14,000	5510 11,890	5270 11,370	4480 9,670	4410 9,520	3760 8,120	3920 8,670	3350 7,390		3930 8,680	3350 7,400	13.14 43.05
-4.5 m -15.0 ft	kg lb					*8760 *18,990	*8760 *18,990	*7520 *16,200	7080 15,260	*6320 *13,550	5500 11,880	*5180 *11,020	4490 9,690	*3610 *8,030	3790						

\*Indicates that the load is limited by hydraulic capacity rather than tipping capacity. Lift capacity ratings are based on SAE J2518 standard. Rated loads do not exceed 87% of hydraulic lifting capacity or 75% of tipping capacity.

All lifts are with heavy lift on. Always refer to the appropriate Operation and Maintenance Manual for specific product information.

**Lift Capacities**

325D MH-Long Stick

**BOOM — 8.85 m (29'0")**  
**STICK — 7.42 m (24'3")**

**MAX REACH — 15.5 m (50'11")**  
**MAX HEIGHT — 16.4 m (53'10")**

**MAX DEPTH — 7.07 m (23'2")**

Lift Point Height	3.0 m/10.0 ft		4.5 m/15.0 ft		6.0 m/20.0 ft		7.5 m/25.0 ft		9.0 m/30.0 ft		10.5 m/35.0 ft		12.0 m/40.0 ft		13.5 m/45.0 ft		15.0 m/50.0 ft		Maximum Reach							
	Over Front	Over Side	Over Front	Over Side	Over Front	Over Side	Over Front	Over Side	Over Front	Over Side	Over Front	Over Side	Over Front	Over Side	Over Front	Over Side	Over Front	Over Side	Over Front	Over Side	m	ft				
15.0 m 50.0 ft	kg																				*3740	*3740	8.58			
	lb																				*8,450	*8,450	26.92			
13.5 m 45.0 ft	kg																				*3320	*3320	10.52			
	lb																				*7,420	*7,420	33.72			
12.0 m 40.0 ft	kg																				*3090	*3090	11.96			
	lb																				*6,870	*6,870	38.69			
10.5 m 35.0 ft	kg																				*2960	*2960	13.06			
	lb																				*6,560	*6,560	42.49			
9.0 m 30.0 ft	kg																				*2890	*2890	13.92			
	lb																				*6,390	*6,390	45.42			
7.5 m 25.0 ft	kg																				*2870	*2870	14.57			
	lb																				*6,320	*6,320	47.65			
6.0 m 20.0 ft	kg																				*2880	*2880	15.04			
	lb																				*6,340	*6,340	49.26			
4.5 m 15.0 ft	kg			*12 990	*12 990	*10 370	*10 370	*8 690	*8 690	*7 520	*7 520	*6 880	*6 880	*6 180	*6 180	*5 370	*5 370	*4 970	*4 310	*4 080	3520	3390	2900	*2930	2780	15.35
	lb			*28,060	*28,060	*22,460	*22,460	*18,840	*18,840	*16,290	*16,290	*14,830	*14,830	*13,310	*11,560	*10,700	*9,260	*8,770	*7,550	*6,910	*6,210	*6,450	*6,140	*5,910	*5,800	50.32
3.0 m 10.0 ft	kg			*15 390	*15 390	*11 570	*11 570	*9 350	8620	7540	6520	5940	5130	4810	4150	3980	3410	3330	2840	3100	3330	2840	3100	2680	15.51	
	lb			*33,220	*33,220	*25,040	*25,040	*20,270	18,590	16,240	14,050	12,780	11,050	10,350	8,920	8,550	7,330	7,100	6,100	*6,630	6,100	6,100	5,910	5,800	50.87	
1.5 m 5.0 ft	kg																									
	lb																									
Ground Line	kg			*7700	*7700	12 350	10 370	8880	7540	6830	5830	5470	4680	4500	3840	3770	3210	3220	2730	3100	3210	2730	3100	2630	15.38	
	lb			*17,690	*17,690	26,580	22,340	19,130	16,260	14,720	12,570	11,780	10,070	9,690	8,270	8,120	6,910	6,930	5,870	6,830	6,930	5,870	6,830	5,790	50.47	
-1.5 m -5.0 ft	kg			*3800	*3800	*6490	*6490	11 800	9850	8510	7180	6570	5580	5290	4500	4380	3720	3700	3140	3140	3180	2700	3160	2670	15.09	
	lb			*8,520	*8,520	*14,700	*14,700	25,390	21,210	18,320	15,480	14,160	12,030	11,400	9,700	9,440	8,020	7,970	6,760	6,760	6,760	5,900	6,960	5,900	49.5	
-3.0 m -10.0 ft	kg			*4380	*4380	*6420	*6420	*10 890	9580	8280	6960	6400	5420	5170	4380	4300	3650	3660	3100				3280	2780	14.65	
	lb			*9,790	*9,790	*14,480	*14,480	24,770	20,620	17,830	15,010	13,800	11,670	11,150	9,450	9,270	7,860	7,890	6,680				7,240	6,130	47.99	
-4.5 m -15.0 ft	kg																									
	lb																									

\*Indicates that the load is limited by hydraulic capacity rather than tipping capacity. Lift capacity ratings are based on SAE J2518 standard. Rated loads do not exceed 87% of hydraulic lifting capacity or 75% of tipping capacity.

All lifts are with heavy lift on. Always refer to the appropriate Operation and Maintenance Manual for specific product information.

**330D MH Range Diagrams**

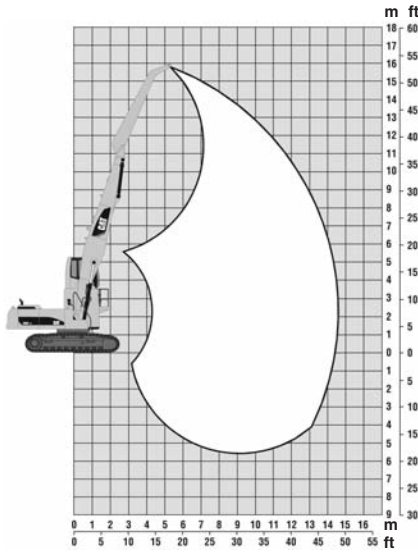

Maximum Reach 14.6 m (47'11")

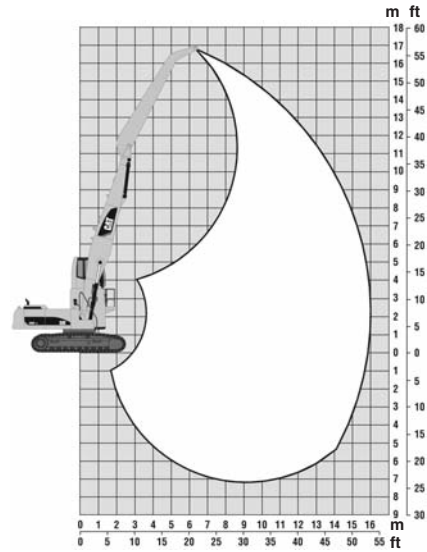

Maximum Reach 16.0 m (52'6")

**330D MH Specifications**



Model	330D MH			
	Long Stick		Short Stick	
Overall Weight	44.6 t	<b>98,400 lb</b>	44.3 t	<b>97,800 lb</b>
Horsepower (Net)	200 kW	<b>268 hp</b>	200 kW	<b>268 hp</b>
Boom Length	9.20 m	<b>30'0"</b>	9.20 m	<b>30'0"</b>
Stick Length	7.60 m	<b>24'11"</b>	6.10 m	<b>20'0"</b>
Maximum Horizontal Reach	16.0 m	<b>52'6"</b>	14.6 m	<b>47'11"</b>
Maximum Vertical Pin Height	16.9 m	<b>55'5"</b>	15.8 m	<b>51'11"</b>
Maximum Depth	7.06 m	<b>23'2"</b>	5.56 m	<b>18'3"</b>

Cab Height (with cab in raised position) 6153 mm (20'2").  
 Cab Height (with cab in lower position) 5477 mm (18'0").

# Excavators — Material Handling

## Lifting Capacities ● 330D MH (U.S./Belgium Sourced)

### Lift Capacities

330D MH



Load Point  
Height



Load Radius  
Over Front



Load Radius  
Over Side





















Load at Maximum  
Reach

**BOOM** — 9.2 m (30'2")  
**STICK** — 6.1 m (20'0")

**MAX REACH** — 14.6 m (47'11")  
**MAX HEIGHT** — 15.8 m (51'11")

**MAX DEPTH** — -5.56 m (-18'3")

		3.0 m/10.0 ft		4.5 m/15.0 ft		6.0 m/20.0 ft		7.5 m/25.0 ft		9.0 m/30.0 ft		10.5 m/35.0 ft		12.0 m/40.0 ft		13.5 m/45.0 ft				m ft			
																							
16.5 m 55.0 ft	kg lb			*6130 *12,250	*6130 *12,250																		
15.0 m 50.0 ft	kg lb					*6320 *13,920	*6320 *13,920	*6110 *6110													*13,990 *13,990	*13,990 *13,990	7.07 21.69
13.5 m 45.0 ft	kg lb							*8310 *17,320	*8310 *17,320	*5330 *11,920	*5330 *11,920										*5350 *11,979	*5350 *11,979	9.3 29.62
12.0 m 40.0 ft	kg lb							*9520 *20,840	*9520 *20,840	*8380 *17,510	*8380 *17,510	*4940 *10,960	*4940 *10,960								*4960 *11,020	*4960 *11,020	10.88 35.1
10.5 m 35.0 ft	kg lb							*9520 *20,760	*9520 *20,760	*8510 *18,560	*8510 *18,560	*7710 *16,760	7630 16,370	*4720 *10,450	*4720 *10,450						*4750 *10,510	*4750 *10,510	12.06 39.19
9.0 m 30.0 ft	kg lb					*10,540 *23,010	*10,540 *23,010	*9730 *21,170	*9730 *21,170	*8620 *18,760	*8620 *18,760	*7740 *16,270	7570 16,270	6540 *10,200	6030 *10,200	*4620 *4620	*4620 *4620				*4650 *10,260	*4650 *10,260	12.97 42.29
7.5 m 25.0 ft	kg lb					*11,930 *25,860	*11,930 *25,860	*10,140 *22,010	*10,140 *22,010	*8850 *19,220	*8850 *19,220	*7850 *17,070	7420 15,980	6460 13,900	5960 12,800	*4590 *10,120	*4590 *10,120	*4620 *10,180	*4620 *10,180		*4620 *10,180	*4620 *10,180	13.65 44.62
6.0 m 20.0 ft	kg lb			*16,500 *35,590	*16,500 *35,590	*12,910 *27,940	*12,910 *27,940	*10,690 *23,170	*10,690 *23,170	*9150 *19,860	*9150 *19,860	7840 16,880	7220 15,550	6340 13,640	5830 12,550	*4630 *10,190	4420 9,790	*4660 *10,170	4430 9,300		*4660 *10,170	*4660 *10,170	14.13 46.29
4.5 m 15.0 ft	kg lb	*23,280 *51,640	*23,280 *51,640	*18,740 *40,420	*18,740 *40,420	*14,000 *30,280	*14,000 *30,280	*11,270 *24,410	*11,270 *24,410	*9460 *20,520	8810 19,010	7500 16,360	6980 15,040	6190 13,320	5680 12,230	5140 10,160	4710 9,290	4600 10,170	4210 9,300		4600 9,300	4210 9,300	14.45 47.37
3.0 m 10.0 ft	kg lb			*8880 *20,080	*8880 *20,080	*14,830 *32,110	*14,830 *32,110	*11,710 *25,380	10,970 23,760	9190 19,820	8420 18,170	7340 15,820	6730 14,500	6020 12,980	5520 11,890	5040 10,850	4610 9,930	4470 9,850	4080 9,000		4470 9,850	4080 9,000	14.6 47.89
1.5 m 5.0 ft	kg lb			*5090 *11,290	*5090 *11,290	*15,010 *32,550	14,300 30,830	11,430 24,650	10,410 22,460	8830 19,040	8070 17,400	7100 15,310	6490 14,010	5870 12,650	5370 11,570	4950 10,660	4520 9,740	4410 9,730	4030 8,880		4410 9,730	4030 8,880	14.6 47.89
0.0 m 0.0 ft	kg lb	*3800 *8,370	*3800 *8,370	*5850 *13,340	*5850 *13,340	*12,360 *28,730	*12,360 *28,730	11,010 23,750	10,000 21,570	8550 18,430	7790 16,800	6910 14,900	6300 13,600	5740 12,380	5240 11,300	4870 9,790	4450 8,930	4440 9,800	4050 8,930		4440 9,800	4050 8,930	14.44 47.37
-1.5 m -5.0 ft	kg lb	*4680 *10,390	*4680 *10,390	*6450 *14,570	*6450 *14,570	*11,060 *25,340	*11,060 *25,340	*10,770 *23,210	9760 21,050	8360 18,020	7600 16,400	6780 14,620	6170 13,320	5660 12,210	5160 11,130	*4460 *9,810	4160 9,170	*4460 *9,830	4160 9,170		*4460 *9,830	4160 9,170	14.12 46.29
-3.0 m -10.0 ft	kg lb			*6770 *15,110	*6770 *15,110	*11,060 *24,350	*11,060 *24,350	*9540 *20,640	*9540 *20,640	*8020 *17,310	7510 16,210	*6700 *14,400	6110 13,180	*5480 *11,670	5120 11,060	*3980 *8,740	*3980 *8,740	*3990 *8,760	*3990 *8,760		*3990 *8,760	*3990 *8,760	13.62 44.62
-4.5 m -15.0 ft	kg lb					*8910 *19,240	*8910 *19,240	*7850 *16,910	*7850 *16,910	*6690 *14,340	*6690 *14,340	*5530 *11,770	*5530 *11,770	*3710 *8,250	*3710 *8,250								

\*Indicates that the load is limited by hydraulic capacity rather than tipping capacity. Lift capacity ratings are based on SAE J2518. Rated payloads do not exceed 87% of hydraulic lifting capacity or 75% of tipping capacity.

All lift values are shown with heavy lift on. Always refer to the appropriate Operation and Maintenance Manual for specific product information.

Lifting Capacities  
 • 330D MH  
 (U.S./Belgium Sourced)

Excavators —  
 Material Handling

Lift Capacities

330D MH



**BOOM** — 9.2 m (30'2")      **MAX REACH** — 16.0 m (52'6")      **MAX DEPTH** — -7.06 m (-23'2")  
**STICK** — 7.6 m (24'11")      **MAX HEIGHT** — 16.9 m (55'5")

Boom Height m ft	3.0 m/10.0 ft		4.5 m/15.0 ft		6.0 m/20.0 ft		7.5 m/25.0 ft		9.0 m/30.0 ft		10.5 m/35.0 ft		12.0 m/40.0 ft		13.5 m/45.0 ft		15.0 m/50.0 ft		Load at Maximum Reach		m ft		
	kg lb	kg lb	kg lb	kg lb	kg lb	kg lb	kg lb	kg lb	kg lb	kg lb	kg lb	kg lb	kg lb	kg lb	kg lb	kg lb	kg lb	kg lb	kg lb	kg lb		kg lb	
16.5 m 55.0 ft					*5450 *11,680		*5080 *5080													*5080 *11,250	*5080 *11,250	7.2 21.78	
15.0 m 50.0 ft							*6590 *14,250	*6590 *14,250	*4310 *9,690	*4310 *9,690										*4330 *9,740	*4330 *9,740	9.67 30.53	
13.5 m 45.0 ft							*15,910	*15,910	*6830 *14,380	*6830 *14,380	*5280 *8,730	*5280 *8,730	*3920 *3920	*3920 *3920						*3940 *8,780	*3940 *8,780	11.37 36.57	
12.0 m 40.0 ft									*7680 *16,820	*7680 *16,820	*6680 *14,020	*6680 *14,020	*3690 *8,180	*3690 *8,180						*3710 *8,230	*3710 *8,230	12.69 41.13	
10.5 m 35.0 ft									*7680 *16,760	*7680 *16,760	*7040 *15,380	*7040 *15,380	*6290 *13,050	*6290 *13,050	*3560 *7,860	*3560 *7,860				*3580 *7,910	*3580 *7,910	13.71 44.67	
9.0 m 30.0 ft							*8210 *17,990	*8210 *17,990	*7810 *17,020	*7810 *17,020	*7110 *15,500	*7110 *15,500	*6520 *14,200	6250 13,410	*5460 *7,690	5050 *7,690	*3490 *3490	*3490 *3490		*3510 *7,740	*3510 *7,740	14.52 47.4	
7.5 m 25.0 ft							*9030 *19,700	*9030 *19,700	*8070 *17,540	*8070 *17,540	*7260 *15,800	*7260 *15,800	*6590 *14,300	6140 13,190	5430 11,640	4990 10,700	*3520 *7,680	*3520 *7,680		*3490 *7,690	*3490 *7,690	15.13 49.49	
6.0 m 20.0 ft					*10,860 *23,560	*10,860 *23,560	*9650 *20,930	*9650 *20,930	*8420 *18,290	*8420 *18,290	*7470 *16,240	*7470 *16,240	6490 13,970	5980 12,860	5330 11,440	4890 10,500	*3940 *8,520	*3940 *8,520		*3510 *7,730	*3510 *7,730	15.57 50.99	
4.5 m 15.0 ft			*16,030 *34,600	*16,030 *34,600	*12,520 *27,100	*12,520 *27,100	*10,330 *22,400	*10,330 *22,400	*8820 *19,140	*8820 *19,140	*7700 *16,720	*7700 *16,720	6300 13,560	5790 12,460	5200 11,180	4770 10,240	*4350 *8,520	*4350 *8,520		*3570 *7,860	*3570 *7,860	15.85 51.98	
3.0 m 10.0 ft	kg lb	*23,670 *52,110	*23,670 *52,110	*18,450 *39,850	*18,450 *39,850	*13,720 *29,690	*13,720 *29,690	*10,990 *23,810	*10,990 *23,810	*9190 *19,930	8690 18,740	7490 16,130	6870 14,810	6090 13,120	5590 12,020	5060 10,890	4630 9,950	4260 8,520	3890 8,520	*3670 *8,090	*3670 *8,090	34.90 7.69	52.46
1.5 m 5.0 ft	kg lb	*6320 *14,130	*6320 *14,130	*13,440 *29,850	*13,440 *29,850	*11,440 *25,160	*11,440 *25,160	10,740 23,170	9010 19,420	8240 17,760	7180 15,480	6570 14,160	5890 12,680	5380 11,590	4920 10,600	4490 9,670	4180 8,520	3800 8,180	3780 8,330	3430 7,570	3430 7,570	15.99 52.46	
0.0 m 0.0 ft	kg lb	*3300 *7,270	*3300 *7,270	*7830 *17,930	*7830 *17,930	*14,670 *31,800	14,000 30,140	11,170 24,060	10,150 21,870	8610 18,560	7850 16,910	6910 15,190	6310 13,590	5700 12,290	5200 11,200	4800 10,340	4370 9,410	4100 8,440	3730 8,030	3790 8,350	3440 7,580	15.84 51.98	
-1.5 m -5.0 ft	kg lb	*4200 *9,420	*4200 *9,420	*6940 *15,720	*6940 *15,720	*13,140 *28,840	10,730 23,120	9720 20,950	8300 17,900	7550 16,270	6700 14,440	6100 13,140	5560 11,980	5060 10,890	4710 10,140	4280 9,210	3960 8,590	3550 7,930	3860 8,510	3500 7,720	3500 7,720	15.55 51.0	
-3.0 m -10.0 ft	kg lb	*4390 *9,780	*4390 *9,780	*7020 *15,820	*7020 *15,820	*11,460 *26,160	*11,460 *26,160	10,470 22,560	9470 20,400	8110 17,470	7350 15,850	6560 14,130	5950 12,830	5460 11,770	4960 10,690	4650 10,030	4220 9,100	*3760 *3760	3670 8,030	*3730 *8,190	3640 8,030	15.1 49.49	
-4.5 m -15.0 ft	kg lb	*5990 *13,430	*5990 *13,430	*7400 *16,630	*7400 *16,630	*11,110 *24,030	*11,110 *24,030	*9260 *19,970	*9260 *19,970	*7730 *16,640	7260 15,650	*6450 *13,830	5880 12,690	*5320 *11,320	4920 10,610	*4190 *7,200	*4190 *7,200		*3300 *7,220	*3300 *7,220	14.49 47.41		
-6.0 m -20.0 ft	kg lb					*8860 *18,990	*8860 *18,990	*7590 *16,250	*7590 *16,250	*6400 *13,660	*6400 *13,660	*5290 *11,210	*5290 *11,210	*4190 *7,460	*4190 *7,460								

\*Indicates that the load is limited by hydraulic capacity rather than tipping capacity. Lift capacity ratings are based on SAE J2518. Rated payloads do not exceed 87% of hydraulic lifting capacity or 75% of tipping capacity.

All lift values are shown with heavy lift on. Always refer to the appropriate Operation and Maintenance Manual for specific product information.

**345C MH Range Diagrams**

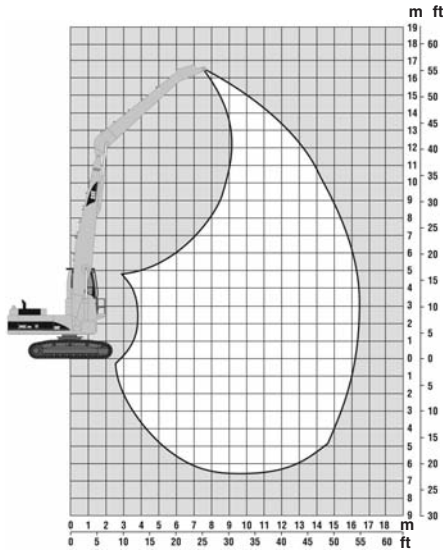

Maximum Reach 16.5 m (54'2")

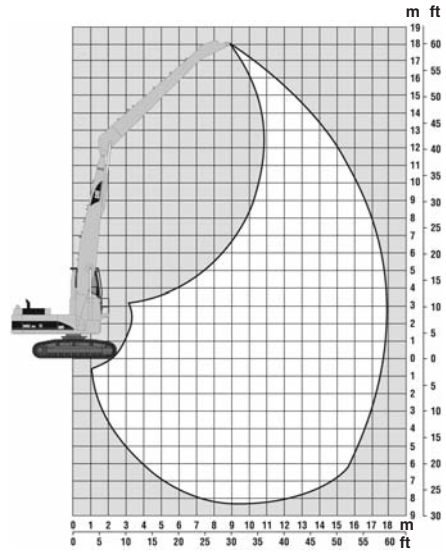

Maximum Reach 18.0 m (59'1")

**345C MH Specifications**



Model	345C MH			
	Long Stick		Short Stick	
Overall Weight	57.4 t	126,600 lb	57.0 t	125,700 lb
Horsepower (Net)	257 kW	345 hp	257 kW	345 hp
Boom Length	9.90 m	32'6"	9.90 m	32'6"
Stick Length	9.10 m	29'10"	6.10 m	20'0"
Maximum Horizontal Reach	18.0 m	59'1"	16.5 m	54'2"
Maximum Vertical Pin Height	18.0 m	59'1"	16.9 m	55'6"
Maximum Depth	8.39 m	27'6"	6.71 m	22'0"

Cab Height (with cab in raised position) 6149 mm (20'2").  
Cab Height (with cab in lower position) 5471 mm (18'0").

**Lift Capacities**

345C MH with 750 mm Track

**BOOM** — 9.9 m (32'6")  
**STICK** — 9.1 m (29'10")

**MAX REACH** — 18 m (59'1")  
**MAX HEIGHT** — 18 m (59'1")

Lift Point Height	4.5 m/15.0 ft		6.0 m/20.0 ft		7.5 m/25.0 ft		9.0 m/30.0 ft		10.5 m/35.0 ft		12.0 m/40.0 ft		13.5 m/45.0 ft		15.0 m/50.0 ft		16.5 m/55.0 ft		18.0 m/60.0 ft		Maximum Reach						
	Over Front	Over Side	Over Front	Over Side	Over Front	Over Side	Over Front	Over Side	Over Front	Over Side	Over Front	Over Side	Over Front	Over Side	Over Front	Over Side	Over Front	Over Side	Over Front	Over Side	Over Front	Over Side	m ft				
16.5 m 55.0 ft	kg lb									*6600 *14,400	*6600 *14,400											*5800 *12,700	*5800 *12,700	11.1 35.2			
15.0 m 50.0 ft	kg lb									*8000 *17,500	*8000 *17,500	*6500 *14,200	*6500 *14,200										*5300 *11,700	*5300 *11,700	12.8 41.2		
13.5 m 45.0 ft	kg lb											*7700 *17,000	*7700 *17,000	*6100 *13,300	*6100 *13,300								*5000 *11,100	*5000 *11,100	14.1 45.8		
12.0 m 40.0 ft	kg lb											*8100 *17,800	*8100 *17,800	*7300 *16,100	*7300 *16,100	*5300 *11,600	*5300 *11,600							*4900 *10,700	*4900 *10,700	15.2 49.5	
10.5 m 35.0 ft	kg lb											*8100 *17,900	*8100 *17,900	*7600 *16,600	*7600 *16,600	*6600 *14,500	*6600 *14,500							*4800 *10,500	*4800 *10,500	16.1 52.5	
9.0 m 30.0 ft	kg lb									*9000 *19,700	*9000 *19,700	*8200 *18,100	*8200 *18,100	*7600 *16,700	*7600 *16,700	*7000 *15,500	6600 14,400	*5300 *11,600	*5300 *11,600					*4700 *10,400	*4700 *10,400	16.8 54.8	
7.5 m 25.0 ft	kg lb									*9200 *20,300	*9200 *20,300	*8400 *18,500	*8400 *18,500	*7700 *17,000	*7700 *17,000	*7100 *15,600	6500 14,200	6300 13,500	5400 12,000					*4700 *10,400	*4700 *10,400	17.3 56.6	
6.0 m 20.0 ft	kg lb							*10 700 *23,600	*10 700 *23,600	*9600 *21,100	*9600 *21,100	*8600 *19,000	*8600 *19,000	*7800 *17,200	7600 16,700	*7100 *15,700	6400 14,000	6200 13,300	5400 11,800					*4800 *10,500	4700 10,400	17.7 57.9	
4.5 m 15.0 ft	kg lb					*13 200 *29,100	*13 200 *29,100	*11 400 *25,000	*11 400 *25,000	*10 000 *21,900	*10 000 *21,900	*8900 *19,500	*8900 *19,500	*8000 *17,500	7400 16,200	7200 15,800	6200 13,700	6100 13,100	5300 11,700					*4900 *10,700	4500 10,000	17.9 58.7	
3.0 m 10.0 ft	kg lb	*23 400 *51,500	*23 400 *51,500	*17 600 *38,800	*17 600 *38,800	*14 200 *31,300	*14 200 *31,300	*12 000 *26,300	*12 000 *26,300	*10 300 *22,700	*10 300 *22,700	*9100 *20,000	8600 18,900	*8100 *17,800	7200 15,700	7000 15,400	6000 13,300	6000 12,900	5200 11,400	*5100 *11,200	4400 9800			*5000 *11,000	4400 9800	18 59.2	
1.5 m 5.0 ft	kg lb	*23 600 *51,800	*23 600 *51,800	*19 100 *42,000	*19 100 *42,000	*15 100 *33,100	*15 100 *33,100	*12 400 *27,400	*12 400 *27,400	*10 600 *23,300	10 100 22,100	*9200 *20,300	8300 18,200	8000 17,700	6900 15,200	6800 15,000	5900 12,900	5900 12,700	5100 11,100	5100 11,300	4400 9600			*5100 *11,300	4400 9600	18 59.1	
0.0 m 0.0 ft	kg lb	*8900 *19,500	*8900 *19,500	*19 700 *43,400	*19 700 *43,400	*15 500 *34,100	*15 500 *34,100	*12 700 *27,900	12 000 26,400	*10 700 *23,600	9600 21,200	*9200 *20,300	8000 17,500	7800 16,800	6700 14,700	6700 14,700	5700 12,600	5800 12,400	5000 10,900					*5100 *11,300	4400 9600	17.9 58.7	
-1.5 m -5.0 ft	kg lb	*7100 *15,600	*7100 *15,600	*14 200 *31,200	*14 200 *31,200	*15 400 *33,900	14 800 32,500	*12 600 *28,700	11 500 25,300	*10 600 *23,400	9300 20,400	9000 19,800	7700 16,900	7600 16,800	6500 14,300	6600 14,400	5600 12,300	5700 12,300	4900 10,700					*4900 *10,700	4400 9700	17.6 57.8	
-3.0 m -10.0 ft	kg lb	*7000 *15,400	*7000 *15,400	*11 700 *25,700	*11 700 *25,700	*14 800 *32,500	14 300 31,400	*12 200 *26,800	11 100 24,400	*10 300 *22,600	9000 19,800	*8800 *19,300	7500 16,500	7 500 16,400	6400 14,000	*6400 *14,000	5500 12,100	*5200 *11,500	4800 10,600					*4600 *10,100	4500 10,000	17.2 56.4	
-4.5 m -15.0 ft	kg lb	*7300 *16,100	*7300 *16,100	*11 000 *24,300	*11 000 *24,300	*13 600 *30,000	*13 600 *30,000	*11 400 *25,000	10 900 23,900	*9600 *21,100	8800 19,400	*8100 *17,900	7400 16,200	*6900 *15,100	6300 13,800	*5700 *12,500	5500 12,000	*4400 *9600	*4400 *9600					*4200 *9200	*4200 *9200	16.7 54.6	
-6.0 m -20.0 ft	kg lb	*7800 *17,200	*7800 *17,200	*11 100 *24,400	*11 100 *24,400	*11 900 *26,300	*11 900 *26,300	*10 100 *22,200	*10 100 *22,200	*8500 *18,700	*8500 *18,700	*7200 *15,600	*7200 *15,600	*5900 *13,000	*5900 *13,000	*4700 *10,200	*4700 *10,200							*3700 *8100	*3700 *8100	16 52.2	
-7.5 m -25.0 ft	kg lb			*11 200 *24,600	*11 200 *24,600	*9700 *21,300	*9700 *21,300	*8300 *18,200	*8300 *18,200	*7000 *15,400	*7000 *15,400	*5800 *12,700	*5800 *12,700	*4600 *10,000	*4600 *10,000												

\*Indicates that the load is limited by hydraulic capacity rather than tipping capacity. Rated loads do not exceed 87% of hydraulic lifting capacity or 75% of tipping capacity. Always refer to the appropriate Operation and Maintenance Manual for specific product information.



# Excavators — Material Handling

## Lifting Capacities ● 345C MH (U.S./Belgium Sourced)

### Lift Capacities

345C MH with 750 mm Track

**BOOM** — 9.9 m (32'6")  
**STICK** — 7.4 m (24'3")

**MAX REACH** — 16.5 m (54'2")  
**MAX HEIGHT** — 16.9 m (55'6")

Lift Point Height	4.5 m/15.0 ft		6.0 m/20.0 ft		7.5 m/25.0 ft		9.0 m/30.0 ft		10.5 m/35.0 ft		12.0 m/40.0 ft		13.5 m/45.0 ft		15.0 m/50.0 ft		Maximum Reach				
	Over Front	Over Side	Over Front	Over Side	Over Front	Over Side	Over Front	Over Side	Over Front	Over Side	Over Front	Over Side	Over Front	Over Side	Over Front	Over Side	Over Front	Over Side	m ft		
16.5 m 55.0 ft																			*7900 *17,500	*7900 *17,500	8.3 25.6
15.0 m 50.0 ft								*9400 *20,600	*9400 *20,600										*7100 *15,500	*7100 *15,500	10.5 33.4
13.5 m 45.0 ft									*9300 *20,400	*9300 *20,400	*6800 *14,900	*6800 *14,900							*6600 *14,500	*6600 *14,500	12.1 39
12.0 m 40.0 ft									*9600 *21,200	*9600 *21,200	*8900 *19,500	*8900 *19,500							*6300 *13,900	*6300 *13,900	13.3 43.3
10.5 m 35.0 ft									*9700 *21,300	*9700 *21,300	*8900 *19,500	*8900 *19,500	*8000 *17,700	7600 16,800					*6200 *13,500	*6200 *13,500	14.3 46.6
9.0 m 30.0 ft								*10 900 *24,000	*10 900 *24,000	*9800 *21,600	*9800 *21,600	*8900 *19,600	*8900 *19,600	*8100 *17,900	7600 16,700	*6300 *13,900	*6300 *13,900	*6100 *13,400	*6100 *13,400	15.1 49.2	
7.5 m 25.0 ft								*11 300 *24,900	*11 300 *24,900	*10 100 *22,100	*10 100 *22,100	*9100 *19,900	*9100 *19,900	*8200 *18,000	7500 16,500	7200 15,900	6300 13,800	*6100 *13,400	5800 12,800	15.7 51.2	
6.0 m 20.0 ft					*13 800 *30,300	*13 800 *30,300	*11 800 *26,000	*11 800 *26,000	*10 400 *22,800	*10 400 *22,800	*9200 *20,300	8900 19,500	*8300 *18,200	7400 16,200	7100 15,700	6200 13,600	*6200 *13,600	5500 12,100	16.1 52.7		
4.5 m 15.0 ft	*24 100 *53,100	*24 100 *53,100	*18 200 *39,900	*18 200 *39,900	*14 700 *32,200	*14 700 *32,200	*12 300 *27,100	*12 300 *27,100	*10 700 *23,400	10 600 23,200	*9400 *20,600	8600 19,000	8300 18,200	7200 15,800	7000 15,500	6100 13,400	6100 13,500	5300 11,600	16.3 53.6		
3.0 m 10.0 ft	*16 800 *37,000	*16 800 *37,000	*19 500 *42,900	*19 500 *42,900	*15 400 *33,900	*15 400 *33,900	*12 800 *28,100	12 700 27,900	*10 900 *24,000	10 200 22,300	*9500 *20,800	8300 18,400	8100 17,800	7000 15,400	6900 15,200	6000 13,100	6000 13,200	5100 11,300	16.5 54		
1.5 m 5.0 ft	*6700 *14,500	*6700 *14,500	*20 100 *44,300	*20 100 *44,300	*15 800 *34,800	15 700 34,500	*13 000 *28,600	12 100 26,700	*11 000 *24,200	9800 21,500	9400 20,600	8100 17,800	7900 17,400	6800 15,000	6800 14,900	5800 12,800	5900 13,000	5100 11,200	16.5 54		
0.0 m 0.0 ft	*5700 *12,600	*5700 *12,600	*12 600 *27,700	*12 600 *27,700	*15 700 *34,500	15 000 33,000	*12 900 *28,400	11 700 25,700	*10 900 *23,900	9500 20,800	9200 20,100	7900 17,300	7800 17,100	6700 14,700	6700 14,700	5700 12,600	*5700 *12,600	5100 11,200	16.3 53.5		
-1.5 m -5.0 ft	*6100 *13,500	*6100 *13,500	*10 800 *23,800	*10 800 *23,800	*15 000 *33,000	14 600 32,000	*12 400 *27,300	11 300 24,900	*10 500 *23,000	9200 20,300	*8900 *19,600	7800 16,900	*7600 *16,700	6500 14,400	*6300 *14,000	5700 12,500	*5400 *11,800	5200 11,400	16 52.5		
-3.0 m -10.0 ft	*6900 *15,200	*6900 *15,200	*10 600 *23,400	*10 600 *23,400	*13 800 *30,300	*13 800 *30,300	*11 500 *25,400	11 100 24,500	*9800 *21,500	9100 19,900	*8300 *18,200	7600 16,700	*6900 *15,200	6500 14,200	*5600 *12,200	*5600 *12,200	*4900 *10,900	*4900 *10,900	15.6 51.1		
-4.5 m -15.0 ft			*11 100 *24,400	*11 100 *24,400	*12 000 *26,300	*12 000 *26,300	*10 200 *22,400	*10 200 *22,400	*8600 *19,000	*8600 *19,000	*7300 *16,000	*7300 *16,000	*5900 *13,000	*5900 *13,000			*4400 *9600	*4400 *9600	15 49		
-6.0 m -20.0 ft					*9600 *21,100	*9600 *21,100	*8300 *18,400	*8300 *18,400	*7100 *15,600	*7100 *15,600	*5800 *12,800	*5800 *12,800									

\*Indicates that the load is limited by hydraulic capacity rather than tipping capacity. Rated loads do not exceed 87% of hydraulic lifting capacity or 75% of tipping capacity. Always refer to the appropriate Operation and Maintenance Manual for specific product information.

**385C MH Range Diagrams**

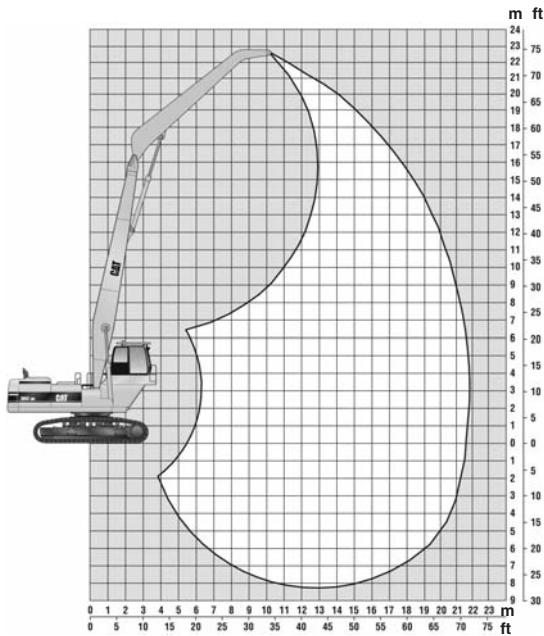

Maximum Reach 21.8 m (71'6")

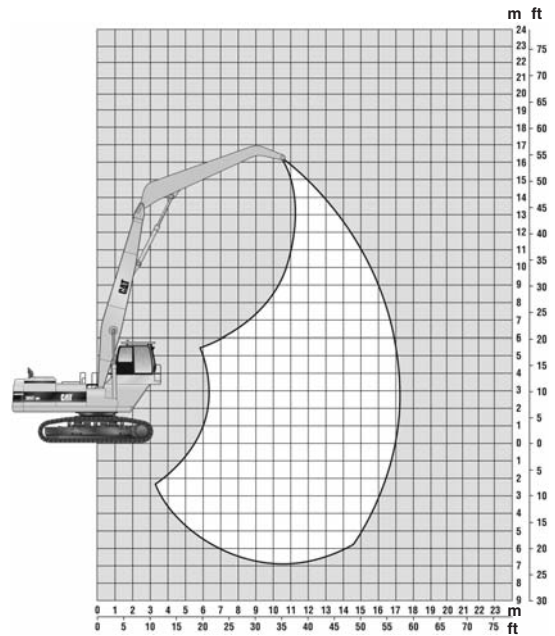

Maximum Reach 17.2 m (56'6")

**385C MH Specifications**



Model	385C MH			
	Long Front		Short Front	
Overall Weight	92.6 t	204,200 lb	92.6 t	204,200 lb
Horsepower (Net)	382 kW	513 hp	382 kW	513 hp
Maximum Horizontal Reach	21.8 m	71'6"	17.2 m	56'6"
Maximum Vertical Pin Height	22.6 m	74'2"	16.3 m	53'3"

# Excavators — Material Handling

## Lifting Capacities ● 385C MH (Belgium Sourced)

### Lift Capacities

385C MH — 21.8 m (71.5') Front





















Load Point  
Height



Load Radius  
Over Front



Load Radius  
Over Side

		4.5 m/ 15.0 ft		6.0 m/ 20.0 ft		9.0 m/ 30.0 ft		12.0 m/ 40.0 ft		13.5 m/ 45.0 ft		15.0 m/ 50.0 ft		18.0 m/ 60.0 ft		19.5 m/ 65.0 ft		21.0 m/ 70.0 ft		Load at Maximum Reach		m ft			
																									
21.0 m 70.0 ft	kg lb							*9980	*9980													*9600	*9600	12.18 38.3	
19.5 m 65.0 ft	kg lb							*25,662	*25,662	*10 120	*10 120											*8750	*8750	14.17 45.3	
18.0 m 60.0 ft	kg lb									*12 060	*12 060	*9860	*9860									*8210	*8210	15.77 50.8	
16.5 m 55.0 ft	kg lb									*13 270	*13 270	*11 730	*11 730									*7830	*7830	17.08 55.3	
15.0 m 50.0 ft	kg lb									*13 230	*13 230	*12 190	*12 190	*8070	*8070							*7580	*7580	18.17 59.1	
13.5 m 45.0 ft	kg lb									*13 280	*13 280	*12 200	*12 200	*10 120	*10 120							*7300	*7300	19.09 62.2	
12.0 m 40.0 ft	kg lb									*13 400	*13 400	*12 270	*12 270	*10 270	*10 090	*8350	*8350					*7300	*7300	19.84 64.8	
10.5 m 35.0 ft	kg lb							*15 010	*15 010	*13 580	*13 580	*12 370	*12 370	10 150	9970	8620	8460					*7250	*7250	20.46 66.9	
9.0 m 30.0 ft	kg lb							*15 350	*15 350	*13 800	*13 800	*12 510	*12 510	9970	9780	8520	8350					*7580	*7580	20.95 68.6	
7.5 m 25.0 ft	kg lb							*20 620	*20 620	*15 710	*15 710	*14 030	*14 030	*12 650	*12 650	9740	9560	8370	8200	7200	7040	6970	6820	21.32 69.8	
6.0 m 20.0 ft	kg lb							*21 490	*21 490	*16 070	*16 070	*14 240	*14 240	*12 770	*12 770	9490	9300	8190	8030	7090	6940	6710	6560	21.58 70.7	
4.5 m 15.0 ft	kg lb							*22 210	*22 210	*16 350	*16 350	*14 410	*14 410	12 490	12 260	9220	9030	8000	7830	6970	6820	6520	6380	21.73 71.3	
3.0 m 10.0 ft	kg lb							*22 650	*22 650	*16 500	*16 500	14 110	13 850	12 000	11 780	8950	8770	7810	7640	6850	6690	6410	6260	21.78 71.5	
1.5 m 5.0 ft	kg lb							*22 650	*22 650	16 030	15 730	13 510	13 250	11 550	11 320	8700	8510	7630	7460	6730	6580	6350	6210	21.72 71.3	
0.0 m 0.0 ft	kg lb							*22 170	*22 170	15 350	15 040	12 990	12 730	11 150	10 930	8470	8290	7470	7300	6640	6480	6370	6220	21.56 70.7	
-1.5 m -5.0 ft	kg lb			*6740	*15,432	*20 990	*20 990	14 810	14 510	12 570	12 310	10 830	10 600	8290	8100	7350	7180	6570	6420			*6240	*6240	21.29 69.8	
-3.0 m -10.0 ft	kg lb	*12,037	*12,037	*7830	*17,813	*19 360	*19 360	14 420	14 120	12 250	11 990	10 580	10 350	8160	7970	7270	7100					*5750	*5750	20.91 68.5	
-4.5 m -15.0 ft	kg lb			*9060	*20,503	*17 890	*17 890	*13 750	*13 750	12 050	11 790	10 420	10 190	*7800	*7800	*6310	*6310					*5160	*5160	20.41 66.9	
-6.0 m -20.0 ft	kg lb					*15 580	*15 580	*12 270	*12 270	*10 770	*10 770	*9370	*9370	*6590	*6590										
-7.5 m -25.0 ft	kg lb							*10 390	*10 390	*9120	*9120	*7830	*7830												

\*Rated by hydraulic capacity rather than stability capacity.

Always refer to the appropriate Operation and Maintenance Manual for specific product information.

**Lift Capacities**

385C MH — 17.2 m (56.5') Front



Load Point Height



Load Radius Over Front



Load Radius Over Side

Load Point Height		4.5 m / 15.0 ft		6.0 m / 20.0 ft		7.5 m / 25.0 ft		9.0 m / 30.0 ft		10.5 m / 35.0 ft		12.0 m / 40.0 ft		13.5 m / 45.0 ft		15.0 m / 50.0 ft		16.5 m / 55.0 ft		Load at Maximum Reach			
		kg	lb	kg	lb	kg	lb	kg	lb	kg	lb	kg	lb	kg	lb	kg	lb	kg	lb	kg	lb	m	ft
15.0 m / 50.0 ft	kg																						
	lb																						
13.5 m / 45.0 ft	kg																						
	lb																						
12.0 m / 40.0 ft	kg																						
	lb																						
10.5 m / 35.0 ft	kg																						
	lb																						
9.0 m / 30.0 ft	kg																						
	lb																						
7.5 m / 25.0 ft	kg																						
	lb																						
6.0 m / 20.0 ft	kg																						
	lb																						
4.5 m / 15.0 ft	kg																						
	lb																						
3.0 m / 10.0 ft	kg																						
	lb																						
1.5 m / 5.0 ft	kg																						
	lb																						
0.0 m / 0.0 ft	kg																						
	lb																						
-1.5 m / -5.0 ft	kg																						
	lb																						
-3.0 m / -10.0 ft	kg																						
	lb																						
-4.5 m / -15.0 ft	kg																						
	lb																						
-6.0 m / -20.0 ft	kg																						
	lb																						

\*Rated by hydraulic capacity rather than stability capacity.

Always refer to the appropriate Operation and Maintenance Manual for specific product information.

**MAGNET SELECTION GUIDE**

Cat MH Model		Recommended Magnet Size (Diameter)					
		1219 mm (48")	1448 mm (57")	1676 mm (66")	1829 mm (72")	1981 mm (78")	2210 mm (87")
Gen. Required (kW)		10	15	20	25	33	40
M318D MH	11.0 m (36'1") Front	X					
M322D MH	12.5 m (40'11") Front		X				
M325D MH	15.6 m (51'4") Front		X				
M325D MH	14.3 m (47'0") Front		X				
M325D LMH	15.6 m (51'4") Front		X				
M325D LMH	14.3 m (47'0") Front			X			
325D MH	15.5 m (50'11") Front		X				
325D MH	14.1 m (46'4") Front			X			
330D MH	16.0 m (52'6") Front			X			
330D MH	14.6 m (47'11") Front			X			
345C MH	18.0 m (59'1") Front			X			
345C MH	16.5 m (54'2") Front				X		
385C MH	21.8 m (71'6") Front				X		
385C MH	17.2 m (56'6") Front						X

**GRAPPLE SELECTION GUIDE**

Cat MH Model		Recommended Orange Peel Grapple Size — m <sup>3</sup> /(yd <sup>3</sup> )								
		0.60 (0.75)	0.76 (1.00)	0.95 (1.25)	1.14 (1.50)	1.5 (2.00)	1.0 (2.50)	2.3 (3.00)	3.0 (4.00)	3.8 (5.00)
M318D MH	11.0 m (36'1") Front	X								
M322D MH	12.5 m (40'11") Front		X							
M325D MH	15.6 m (51'4") Front	X								
M325D MH	14.3 m (47'0") Front		X							
M325D LMH	15.6 m (51'4") Front		X							
M325D LMH	14.3 m (47'0") Front			X						
325D MH	15.5 m (50'11") Front	X								
325D MH	14.1 m (46'4") Front			X						
330D MH	16.0 m (52'6") Front			X						
330D MH	14.6 m (47'11") Front				X					
345C MH	18.0 m (59'1") Front				X					
345C MH	16.5 m (54'2") Front					X				
385C MH	21.8 m (71'6") Front						X			
385C MH	17.2 m (56'6") Front									X

\*No rotation.

Grapple size must be matched to the machine size, linkage configuration and considering material density. For material density in the 1200 kg/m<sup>3</sup> (2000 lb/yd<sup>3</sup>) range the grapple in the table above can be used. For different material densities, please contact your Cat dealer for other grapple options.

**INSTITUTE OF SCRAP RECYCLING  
INDUSTRIES INC.**

**Scrap Specifications  
Guidelines for Ferrous Scrap**

**ISRI**

**Code Definition**

- 200 **No. 1 heavy melting steel.** Wrought iron and/or steel scrap 6.35 mm (¼ in) and over in thickness. Individual pieces not over 1524 × 610 mm (60 × 24 in) (charging box size) prepared in a manner to insure compact charging.
- 203 **No. 2 heavy melting steel.** Wrought iron and steel scrap, black and galvanized, 3.18 mm (⅛ in) and over in thickness, charging box size to include material not suitable as No. 1 heavy melting steel. Prepared in a manner to insure compact charging.
- 207 **No. 1 busheling.** Clean steel scrap, not exceeding 305 mm (12 in) in any dimensions, including new factory busheling (for example, sheet clippings, stampings, etc.). May not include old auto body and fender stock. Free of metal coated, limed, vitreous enameled, and electrical sheet containing over 0.5 percent silicon.
- 208 **No. 1 bundles.** New black steel sheet scrap, clippings or skeleton scrap, compressed or hand banded, to charging box size, and weighing not less than 34 kg (75 lb) per cubic foot. (Hand bundles are tightly secured for handling with a magnet.) May include Stanley balls or mandrel wound bundles or skeleton reels, tightly secured. May include chemically detinned material. May not include old auto body or fender stock. Free of metal coated, limed, vitreous enameled, and electrical sheet containing over 0.5 percent silicon.

- 209 **No. 2 bundles.** Old black and galvanized steel sheet scrap, hydraulically compressed to charging box size and weighing not less than 34 kg (75 lb) per cubic foot. May not include tin or lead-coated material of vitreous enameled material.
- 210 **Shredded Scrap.** Homogeneous iron and steel scrap magnetically separated, originating from automobiles, unprepared No. 1 and No. 2 steel, miscellaneous baling and sheet scrap. Average density 23 kg (50 lb) per cubic foot.
- 211 **Shredded Scrap.** Homogeneous iron and steel scrap magnetically separated, originating from automobiles, unprepared No. 1 and No. 2 steel, miscellaneous baling and sheet scrap. Average density 34 kg (70 lb) per cubic foot.
- 219 **Machine shop turnings.** Clean steel or wrought iron turnings, free of iron borings, nonferrous metals in a free state, scale, or excessive oil. May not include badly rusted or corroded stock.
- 231 **Plate and structural steel, 1.5 m (5 ft) and under.** Cut structural and plate scrap, 1.5 m (5 ft) and under. Clean open hearth steel plates, structural shapes, crop ends, shearings, or broken steel tires. Dimensions not less than 6.35 mm (¼ in) thickness, not over 1.5 m (5 ft) in length and 457 mm (18 in) in width. Phosphorous or sulphur not over 0.05 percent.
- 234 **Punchings and plate scrap.** Punchings or stampings, plate scrap, and bar crops containing not over 0.05 percent phosphorous or sulphur and not over 0.5 percent silicon, free from alloys. All materials cut 305 mm (12 in) and under, and with the exception of punchings or stampings, at least 3.18 mm (⅛ in) in thickness. Punchings or stampings under 152 mm (6 in) in diameter may be any gauge.



# BACKHOE LOADERS

## CONTENTS

- Features .....5-1
- Specifications .....5-3
- 416E:
  - Performance Data .....5-6
  - Lift Capacities .....5-8
- 420E/420E IT:
  - Performance Data .....5-11
  - Lift Capacities .....5-17
- 422E2:
  - Performance Data .....5-20
- 428E2:
  - Performance Data .....5-22
- 430E/430E IT:
  - Performance Data .....5-25
  - Lift Capacities .....5-31
- 432E2:
  - Performance Data .....5-34
- 434E2 Mechanical:
  - Performance Data .....5-37
- 434E2 Pilot:
  - Performance Data .....5-40
- 442E2:
  - Performance Data .....5-42
- 444E2:
  - Performance Data .....5-44
- 450E:
  - Performance Data .....5-46
  - Lift Capacities .....5-48
- Backhoe Bucket Capacities .....5-49
- Work Tools .....5-51

## Features:

- **Center pivot backhoe** — 416E, 420E, 430E, 450E.
- **Side shift backhoe** — 422E2, 428E2, 432E2, 434E2 Mechanical, 434E2 Pilot, 442E2, 444E2.
- **Single-tilt loader** features divergent loader arms, a narrow loader tower and single bucket tilt cylinder for improved visibility.
- **Integrated toolcarrier (parallel lift) loader** offers maximum lift and breakout forces, divergent loader arms, and parallel lift for efficient loading and material handling.
  - **Hydraulic Quick Coupler** provides versatility and allows quick connection to selected work tools for the Cat family of integrated toolcarriers.
- **Excavator-style backhoe** provides enhanced visibility even with narrow buckets, ability to reach over obstacles, and faster, easier truck loading.
  - **Backhoe Quick Coupler** offerings include a convenient “pin grabber” and versatile “pin puller” for use with D/E Series and competitive work tools.
- **Load-sensing hydraulic system** provides full hydraulic power to implements at all engine speeds, low fuel consumption, smooth control and low lever efforts. A dual-setting torque limiter automatically optimizes hydraulics.

**Backhoe Loader Website for Dealers** on Infocast offers latest, updated information. This comprehensive site contains all published and unpublished supporting materials for backhoe loaders in the North American Commercial Division.

<https://nacd.cat.com/infocast/frames/products/bcp/bhlit/>



- **Pilot operated backhoe controls** provide smooth, efficient operation and operator comfort. Not available on 416E, 422E2, 428E2, 434E2 Mechanical. New thumb roller controllers provide ergonomic function of the extendible stick and/or auxiliary hydraulic circuits. Convenient pattern changer switch is within the cab.
- **Pilot operated stabilizer controls** are standard on 420E, 430E, 432E2, 442E2, 444E2, and 450E. Auto-up stabilizers are standard with the deluxe cab.
- **The Cat C4.4 ACERT Direct Injection Turbocharged Aftercooled engine** meets all U.S. EPA Tier 3/EU Stage IIIA emission requirements. The efficient fuel system delivers reliable engine lug performance. Some models are powered with Cat 3054C DIT engine.
- **XT-3 ES** hoses combined with Cat couplings and O-ring face seal fittings provide a dry, reliable machine. The E Series backhoe circuits incorporate the XT-3 ES ToughGuard hoses.
- **Operator station features:** Air-suspension seat is standard on all models. Adjustable tilt steering is standard except on 416E and 422E2. Rear, door and side windows can be fully opened for enhanced ventilation and cab roof is extended to help keep operator dry. Four-post Rollover Protective Structure (ROPS) for increased protection. Fully featured, a Deluxe Cab option will feature pilot operated joystick controls, state-of-the-art control panels with white-faced gauges mounted in a rotating vandal cover, pilot operated stabilizer controls with automatic hold upon lifting, and additional system monitoring including service indicators for engine air cleaner, water-in-fuel, and hydraulic filter.
- **High performance backhoe linkage** offers 205° of bucket rotation with one pin position. New backhoe geometry creates more stick force, brought closer to the operator to pull spoil through trench. The 450E has a backhoe bucket rotation of 198°.
- **Diagonal Retention System (DRS)** standard on all factory installed buckets with weld-on tooth adapters, excluding the 450E. Bucket teeth are attached with diagonal pins rather than horizontal pins for easy exchange of bucket teeth. 450E buckets remain fitted with J225 size, horizontal fastener pins. All other buckets have bolt-on Uni-teeth.
- **Integrated lift eye** on backhoe linkage. Object handling installation available on 428E2, 432E2, 434E2 Mechanical, 434E2 Pilot, 442E2, 444E2 for EU countries.
- **Cat Cushion Swing** system smooths the swing function, improving the return-to-trench controllability.
- **The extendible stick** is redesigned to offer object clamping while extending. Serrated edges secure clamped objects. New wear pad configuration eases adjustment on all four sliding surfaces. All sticks have thumb mounts.
- **The hydraulic system** uses load sensing, flow sharing valves with anti-drift characteristics. Smooth, multi-function operation with the ability to have maximum lifting and digging forces at any RPM.
- **Ride Control** available as an option on all E Series machines. The Ride-Control system smooths the ride under all job-site conditions.
- **4F/4R fully synchronized gear box** provides on-the-go shifting in all gears and on-the-go engagement of optional all wheel drive. Maximum, level travel speed increased to 40 km/h (25 mph).
- **Auto-Shift transmission** is available as an option on E Series and is standard on 450E for operator comfort and efficiency.
- **Brakes** are oil immersed, multi-disc, self adjusting, and wear surface is made of Kevlar for long service life. Brakes are boosted on 420E, 430E and 450E models.
- **All Wheel Drive** is available as an option on all E Series machines, standard on the 430E and 450E. It improves mobility and loader performance in poor traction conditions and can be engaged at any time in any operating condition. Includes 4-wheel braking effect feature.
- **Sloping, flip-open hood** allows excellent visibility to the loader working area and tilts forward for single location access to all daily service points.
- **Dry-type, radial seal air cleaner** with automatic, integrated dust ejector system provides efficient pre-separation. The two-stage air filter incorporates both air cleaner and pre-cleaner functions into a single unit mounted under the hood.



MODEL	416E		420E/420E IT		422E2		428E2	
Flywheel Power								
Gross (Tier 3/Stage IIIA)	70 kW	<b>94 hp</b>	75 kW	<b>101 hp</b>	70 kW	<b>94 hp</b>	70 kW*	<b>94 hp*</b>
Net (Tier 3/Stage IIIA)	66 kW	<b>89 hp</b>	70 kW	<b>94 hp</b>	67 kW	<b>90 hp</b>	67 kW	<b>90 hp</b>
Gross (Tier 2/Stage II)	—	—	—	—	56.5 kW*	<b>76 hp*</b>	68.5 kW*	<b>92 hp*</b>
Net (Tier 2/Stage II)	—	—	—	—	55 kW	<b>74 hp</b>	65 kW	<b>87 hp</b>
Net Torque Rise at 1400 rpm								
Tier 3/Stage IIIA	<b>35%</b>		<b>36%</b>		<b>30%</b>		<b>30%</b>	
Tier 2/Stage II	—		—		<b>22%</b>		<b>33%</b>	
Peak Torque at 1400 rpm								
Tier 3/Stage IIIA	384 N·m	<b>283 lb-ft</b>	408 N·m	<b>301 lb-ft</b>	395 N·m	<b>291 lb-ft</b>	395 N·m	<b>291 lb-ft</b>
Tier 2/Stage II	—		—		298 N·m	<b>220 lb-ft</b>	395 N·m	<b>291 lb-ft</b>
Operating Weight	6750 kg	<b>14,881 lb</b>	6895 kg	<b>15,201 lb</b>	7599 kg	<b>16,753 lb</b>	8135 kg	<b>17,935 lb</b>
Engine Model	<b>C4.4 DITAAC</b>		<b>C4.4 EDIT</b>		<b>C4.4 DITAAC (Stage IIIA)/ 3054C DINA (Stage II)</b>		<b>C4.4 DITAAC (Stage IIIA)/ 3054C DINA (Stage II)</b>	
Rated Engine RPM	<b>2200</b>		<b>2200</b>		<b>2200</b>		<b>2200</b>	
No. of Cylinders	<b>4</b>		<b>4</b>		<b>4</b>		<b>4</b>	
Bore	105 mm	<b>4.13 in</b>	105 mm	<b>4.13 in</b>	105 mm	<b>4.13 in</b>	105 mm	<b>4.13 in</b>
Stroke	127 mm	<b>5 in</b>	127 mm	<b>5 in</b>	127 mm	<b>5 in</b>	127 mm	<b>5 in</b>
Displacement	4.4 L		4.4 L		4.4 L		4.4 L	
	<b>Forward</b>	<b>Reverse</b>	<b>Forward</b>	<b>Reverse</b>	<b>Forward</b>	<b>Reverse</b>	<b>Forward</b>	<b>Reverse</b>
Speeds (Power Shuttle)	km/h	mph	km/h	mph	km/h	mph	km/h	mph
1st	6	<b>4</b>	6	<b>4</b>	6	<b>4</b>	6	<b>4</b>
2nd	10	<b>6</b>	10	<b>6</b>	10	<b>6</b>	10	<b>6</b>
3rd	20	<b>12</b>	20	<b>12</b>	20	<b>12</b>	20	<b>12</b>
4th	40	<b>25</b>	40	<b>25</b>	40	<b>25</b>	40	<b>25</b>
Speeds (Auto-Shift/Powershift)								
1st	—	—	6	<b>4</b>	6	<b>4</b>	6	<b>4</b>
2nd	—	—	10	<b>6</b>	13	<b>8</b>	9	<b>5</b>
3rd	—	—	20	<b>12</b>	27	<b>17</b>	27	<b>12</b>
4th	—	—	27	<b>17</b>	—	—	27	<b>16</b>
5th	—	—	40	<b>25</b>	—	—	40	<b>25</b>
Turning Circle Wall to Wall	10.97 m	<b>36'0"</b>	10.97 m	<b>36'0"</b>	10.83 m	<b>35'5"</b>	10.80 m	<b>35'4"</b>
Tires								
2WD Bias Front	<b>11L-16 12 PR F-3</b>		<b>11L-16 12 PR F-3</b>		<b>11L-16 12 PR F-3</b>		—	
2WD Bias Rear	<b>19.5L-24 12 PR R4</b>		<b>19.5L-24 12 PR R4</b>		<b>16.9 x 28 12 PR R4</b>		—	
AWD Bias Front	<b>12.5/80-18 NHS 10 PR</b>		<b>12.5/80-18 NHS 10 PR</b>		<b>12.5/80 x 18 10 PR I-3</b>		<b>12.5/80 x 18 10 PR I-3</b>	
AWD Bias Rear	<b>19.5L-24 12 PR R4</b>		<b>19.5L-24 12 PR R4</b>		<b>16.9 x 28 12 PR R4</b>		<b>16.9 x 28 12 PR R4</b>	
AWD Bias Front	<b>12.5/80-18 NHS 10 PR</b>		<b>12.5/80-18 NHS 10 PR</b>		—		—	
AWD Bias Rear, Flotation	<b>21L-24 16 PR</b>		<b>21L-24 16 PR</b>		—		—	
AWD Radial Front	<b>340/80R18</b>		<b>340/80R18</b>		<b>340/80R18</b>		<b>340/80R18</b>	
AWD Radial Rear	<b>500/70R24</b>		<b>500/70R24</b>		<b>440/80R28</b>		<b>440/80R28</b>	
AWD Combination Front	<b>340/80R18</b>		<b>340/80R18</b>		—		—	
AWD Combination Rear	<b>19.5L-24 12 PR R4</b>		<b>19.5L-24 12 PR R4</b>		—		—	
Hydraulic System, closed center	<b>Load Sensing, Flow Sharing</b>		<b>Load Sensing, Flow Sharing</b>		<b>Load Sensing, Flow Sharing</b>		<b>Load Sensing, Flow Sharing</b>	
Pump Capacity	125 L/min @ 2200 rpm @ 22 700 kPa	<b>33 gpm @ 2200 rpm @ 3292 psi</b>	125 L/min @ 2200 rpm @ 22 700 kPa	<b>33 gpm @ 2200 rpm @ 3292 psi</b>	125 L/min @ 2200 rpm @ 22 700 kPa	<b>33 gpm @ 2200 rpm @ 3292 psi</b>	125 L/min @ 2200 rpm @ 22 700 kPa	<b>33 gpm @ 2200 rpm @ 3292 psi</b>
Fuel Tank Capacity	170 L	<b>45 U.S. gal</b>	170 L	<b>45 U.S. gal</b>	160 L	<b>42 U.S. gal</b>	160 L	<b>42 U.S. gal</b>

\*With optional turbocharger: 422E2 — Stage II — 68.5 kW (92 hp).  
 428E2 — Stage II — 74.5 kW (101 hp).  
 428E2 — Stage IIIA — 74.5 kW (101 hp).



MODEL	430E/430E IT				432E2				434E2 Mechanical				434E2 Pilot			
Flywheel Power																
Gross (Tier 3/Stage IIIA)	83 kW	<b>111 hp</b>			70 kW*	<b>94 hp*</b>			70 kW*	<b>94 hp*</b>			74.5 kW	<b>101 hp</b>		
Net (Tier 3/Stage IIIA)	76 kW	<b>102 hp</b>			67 kW	<b>90 hp</b>			67 kW	<b>90 hp</b>			71 kW	<b>97 hp</b>		
Gross (Tier 2/Stage II)	—				68.5 kW*	<b>92 hp*</b>			68.5 kW*	<b>92 hp*</b>			74.5 kW	<b>101 hp</b>		
Net (Tier 2/Stage II)	—				65 kW	<b>87 hp</b>			65 kW	<b>87 hp</b>			71 kW	<b>97 hp</b>		
Net Torque Rise at 1400 rpm																
Tier 3/Stage IIIA	<b>43%</b>				<b>30%</b>				<b>30%</b>				<b>23%</b>			
Tier 2/Stage II	—				<b>33%</b>				<b>33%</b>				<b>26%</b>			
Peak Torque at 1400 rpm																
Tier 3/Stage IIIA	473 N·m	<b>349 lb·ft</b>			395 N·m	<b>291 lb·ft</b>			395 N·m	<b>291 lb·ft</b>			400 N·m	<b>295 lb·ft</b>		
Tier 2/Stage II	—				395 N·m	<b>291 lb·ft</b>			395 N·m	<b>291 lb·ft</b>			408 N·m	<b>301 lb·ft</b>		
Operating Weight	7125 kg	<b>15,708 lb</b>			8448 kg	<b>18,625 lb</b>			8979 kg	<b>19,795 lb</b>			9185 kg	<b>20,249 lb</b>		
Engine Model	<b>C4.4 EDITAAC</b>				<b>C4.4 DITAAC (Stage IIIA)/3054C DIT (Stage II)</b>				<b>C4.4 DITAAC (Stage IIIA)/3054C DIT (Stage II)</b>				<b>C4.4 DITAAC (Stage IIIA)/3054C DIT (Stage II)</b>			
Rated Engine RPM	<b>2200</b>				<b>2200</b>				<b>2200</b>				<b>2200</b>			
No. of Cylinders	<b>4</b>				<b>4</b>				<b>4</b>				<b>4</b>			
Bore	105 mm	<b>4.13 in</b>			105 mm	<b>4.13 in</b>			105 mm	<b>4.13 in</b>			105 mm	<b>4.13 in</b>		
Stroke	127 mm	<b>5 in</b>			127 mm	<b>5 in</b>			127 mm	<b>5 in</b>			127 mm	<b>5 in</b>		
Displacement	4.4 L	<b>268 in³</b>			4.4 L	<b>268 in³</b>			4.4 L	<b>268 in³</b>			4.4 L	<b>268 in³</b>		
	<b>Forward Reverse</b>				<b>Forward Reverse</b>				<b>Forward Reverse</b>				<b>Forward Reverse</b>			
Speeds (Power Shuttle)	km/h	<b>mph</b>	km/h	<b>mph</b>	km/h	<b>mph</b>	km/h	<b>mph</b>	km/h	<b>mph</b>	km/h	<b>mph</b>	km/h	<b>mph</b>	km/h	<b>mph</b>
1st	6	<b>4</b>	6	<b>4</b>	6	<b>4</b>	6	<b>4</b>	6	<b>4</b>	6	<b>4</b>	—	—	—	—
2nd	10	<b>6</b>	10	<b>6</b>	10	<b>6</b>	10	<b>6</b>	10	<b>6</b>	10	<b>6</b>	—	—	—	—
3rd	20	<b>12</b>	20	<b>12</b>	20	<b>12</b>	20	<b>12</b>	20	<b>12</b>	20	<b>12</b>	—	—	—	—
4th	40	<b>25</b>	40	<b>25</b>	40	<b>25</b>	40	<b>25</b>	40	<b>25</b>	40	<b>25</b>	—	—	—	—
Speeds Forward (Auto-Shift/Powershift)																
1st	6	<b>4</b>	6	<b>4</b>	6	<b>4</b>	6	<b>4</b>	3	<b>3</b>	5	<b>3</b>	6	<b>4</b>	6	<b>4</b>
2nd	10	<b>6</b>	13	<b>8</b>	10	<b>6</b>	13	<b>8</b>	9	<b>6</b>	11	<b>7</b>	10	<b>6</b>	13	<b>8</b>
3rd	20	<b>12</b>	27	<b>17</b>	20	<b>12</b>	27	<b>17</b>	18	<b>11</b>	24	<b>14</b>	20	<b>12</b>	27	<b>17</b>
4th	27	<b>17</b>	—	—	27	<b>17</b>	—	—	25	<b>15</b>	—	—	27	<b>17</b>	—	—
5th	40	<b>25</b>	—	—	40	<b>25</b>	—	—	38	<b>24</b>	—	—	40	<b>25</b>	—	—
Turning Circle Wall to Wall	10.97 m	<b>36'0"</b>			10.80 m	<b>35'4"</b>			16.5 m	<b>54'2"</b>			16.5 m	<b>54'2"</b>		
All Wheel Steer, Wall to Wall																
Circle Steer	—				—				11.8 m	<b>38'9"</b>			11.8 m	<b>38'9"</b>		
Independent Steer	—				—				11.1 m	<b>36'5"</b>			11.1 m	<b>36'5"</b>		
Tires																
2WD Bias Front	<b>11L-16 12 PR F-3</b>				—				—				—			
2WD Bias Rear	<b>19.5L-24 12 PR R4</b>				—				—				—			
AWD Bias Front	<b>12.5/80 x 18 10 PR I-3</b>				<b>12.5/80 x 18 10 PR I-3</b>				—				—			
AWD Bias Rear	<b>19.5L-24 12 PR R4</b>				<b>16.9 x 28 12 PR R4</b>				—				—			
AWD Bias Front	<b>12.5/80-18 NHS 10 PR</b>				—				—				—			
AWD Bias Rear, Flotation	<b>21L-24 16 PR</b>				—				—				—			
AWD Radial Front	<b>340/80R18</b>				<b>340/80R18</b>				<b>440/80R24</b>				<b>440/80R24</b>			
AWD Radial Rear	<b>500/70R24</b>				<b>440/80R28</b>				<b>440/80R24</b>				<b>440/80R24</b>			
AWD Combination Front	<b>340/80R18 XMCL</b>				—				—				—			
AWD Combination Rear	<b>19.5L-24 12 PR R4</b>				—				—				—			
Hydraulic System, closed center	<b>Load Sensing, Flow Sharing</b>				<b>Load Sensing, Flow Sharing</b>				<b>Load Sensing, Flow Sharing</b>				<b>Load Sensing, Flow Sharing</b>			
Pump Capacity	125 L/min @ 2200 rpm	@ 22 700 kPa			125 L/min @ 2200 rpm	@ 22 700 kPa			125 L/min @ 2200 rpm	@ 22 700 kPa			125 L/min @ 2200 rpm	@ 22 700 kPa		
	<b>33 gpm @ 2200 rpm @ 3292 psi</b>				<b>33 gpm @ 2200 rpm @ 3292 psi</b>				<b>33 gpm @ 2200 rpm @ 3292 psi</b>				<b>33 gpm @ 2200 rpm @ 3292 psi</b>			
Fuel Tank Capacity	170 L	<b>45 U.S. gal</b>			160 L	<b>42 U.S. gal</b>			160 L	<b>42 U.S. gal</b>			160 L	<b>42 U.S. gal</b>		

\*With optional turbocharger: 432E2 — Tier II/Tier IIIA — 74.5 kW (101 hp).  
434E2 Mechanical — Tier II/Tier IIIA — 74.5 kW (101 hp).

Specifications  
● All Wheel Steer

Backhoe Loaders



MODEL	442E2				444E2				450E			
Flywheel Power												
Gross (Tier 3/Stage IIIA)	74.5 kW	<b>101 hp</b>		74.5 kW	<b>101 hp</b>		74.5 kW	<b>101 hp</b>		102 kW	<b>137 hp</b>	
Net (Tier 3/Stage IIIA)	71 kW	<b>97 hp</b>		71 kW	<b>97 hp</b>		71 kW	<b>97 hp</b>		92 kW	<b>124 hp</b>	
Gross (Tier 2/Stage II)	74.5 kW	<b>101 hp</b>		74.5 kW	<b>101 hp</b>		74.5 kW	<b>101 hp</b>		—	—	
Net (Tier 2/Stage II)	71 kW	<b>97 hp</b>		71 kW	<b>97 hp</b>		71 kW	<b>97 hp</b>		—	—	
Net Torque Rise at 1400 rpm												
Tier 3/Stage IIIA	<b>23%</b>				<b>23%</b>				<b>28%</b>			
Tier 2/Stage II	<b>26%</b>				<b>26%</b>				—			
Peak Torque at 1400 rpm												
Tier 3/Stage IIIA	400 N·m	<b>295 lb-ft</b>		400 N·m	<b>295 lb-ft</b>		400 N·m	<b>295 lb-ft</b>		514 N·m	<b>380 lb-ft</b>	
Tier 2/Stage II	408 N·m	<b>301 lb-ft</b>		408 N·m	<b>301 lb-ft</b>		408 N·m	<b>301 lb-ft</b>		—	—	
Operating Weight	8782 kg	<b>19,361 lb</b>		8782 kg	<b>19,361 lb</b>		9757 kg	<b>21,511 lb</b>		10 950 kg	<b>24,141 lb</b>	
Engine Model	<b>C4.4 DITAAC (Stage IIIA)/ 3054C DIT (Stage II)</b>				<b>C4.4 DITAAC (Stage IIIA)/ 3054C DIT (Stage II)</b>				<b>C4.4 EDITAAC</b>			
Rated Engine RPM	<b>2200</b>				<b>2200</b>				<b>2200</b>			
No. of Cylinders	<b>4</b>				<b>4</b>				<b>4</b>			
Bore	105 mm	<b>4.13 in</b>		105 mm	<b>4.13 in</b>		105 mm	<b>4.13 in</b>		105 mm	<b>4.13 in</b>	
Stroke	127 mm	<b>5 in</b>		127 mm	<b>5 in</b>		127 mm	<b>5 in</b>		127 mm	<b>5 in</b>	
Displacement	4.4 L	<b>268 in<sup>3</sup></b>		4.4 L	<b>268 in<sup>3</sup></b>		4.4 L	<b>268 in<sup>3</sup></b>		4.4 L	<b>268 in<sup>3</sup></b>	
	<b>Forward</b>		<b>Reverse</b>		<b>Forward</b>		<b>Reverse</b>		<b>Forward</b>		<b>Reverse</b>	
Speeds (Power Shuttle)	km/h	<b>mph</b>	km/h	<b>mph</b>	km/h	<b>mph</b>	km/h	<b>mph</b>	km/h	<b>mph</b>	km/h	<b>mph</b>
1st	6	<b>4</b>	6	<b>4</b>	—	—	—	—	—	—	—	—
2nd	10	<b>6</b>	10	<b>6</b>	—	—	—	—	—	—	—	—
3rd	20	<b>12</b>	20	<b>12</b>	—	—	—	—	—	—	—	—
4th	40	<b>25</b>	40	<b>25</b>	—	—	—	—	—	—	—	—
Speeds (Auto-Shift)												
1st	6	<b>4</b>	6	<b>4</b>	6	<b>4</b>	6	<b>4</b>	6	<b>4</b>	6	<b>4</b>
2nd	10	<b>6</b>	12	<b>8</b>	10	<b>6</b>	12	<b>8</b>	10	<b>6</b>	12	<b>8</b>
3rd	20	<b>12</b>	27	<b>17</b>	20	<b>12</b>	27	<b>17</b>	20	<b>12</b>	27	<b>17</b>
4th	27	<b>17</b>	—	—	27	<b>17</b>	—	—	27	<b>17</b>	—	—
5th	40	<b>25</b>	—	—	40	<b>25</b>	—	—	40	<b>25</b>	—	—
Turning Circle, Wall to Wall	10.84 m	<b>35'7"</b>		19.4 m	<b>63'6"</b>		11.18 m	<b>36'8"</b>		—	—	
All Wheel Steer, Wall to Wall												
Circle Steer	9.3 m	<b>30'5"</b>		12.9 m	<b>42'3"</b>		—	—		—	—	
Independent Rear	9.2 m	<b>30'1"</b>		11.9 m	<b>39'0"</b>		—	—		—	—	
Tires												
AWD Bias Front	<b>12.5/80-18 14 PR</b>				—				<b>15-19.5 12 PR</b>			
AWD Bias Rear	<b>18.4/15-26 12 PR R4</b>				—				<b>21L-24 18 PR R4</b>			
AWD Radial Front	<b>340/80R18</b>				<b>440/80R28</b>				—			
AWD Radial Rear	<b>440/80R28</b>				<b>440/80R28</b>				—			
Hydraulic System, closed center	<b>Load Sensing, Flow Sharing</b>				<b>Load Sensing, Flow Sharing</b>				<b>Load Sensing, Flow Sharing</b>			
Pump Capacity	125 L/min @ 2200 rpm @ 22 700 kPa <b>33 gpm @ 2200 rpm @ 3292 psi</b>				125 L/min @ 2200 rpm @ 22 700 kPa <b>33 gpm @ 2200 rpm @ 3292 psi</b>				125 L/min @ 2200 rpm @ 22 700 kPa <b>33 gpm @ 2200 rpm @ 3292 psi</b>			
Fuel Tank Capacity	160 L	<b>42 U.S. gal</b>		160 L	<b>42 U.S. gal</b>		144 L	<b>38 U.S. gal</b>		—	—	

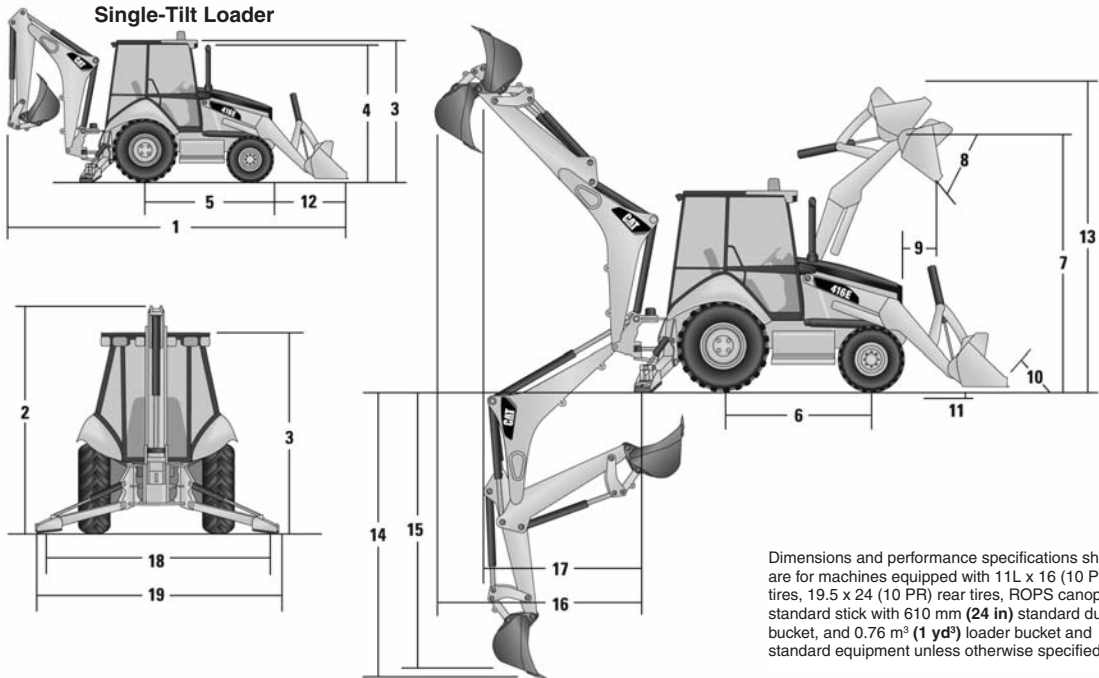

Dimensions and performance specifications shown are for machines equipped with 11L x 16 (10 PR) front tires, 19.5 x 24 (10 PR) rear tires, ROPS canopy, standard stick with 610 mm (24 in) standard duty bucket, and 0.76 m<sup>3</sup> (1 yd<sup>3</sup>) loader bucket and standard equipment unless otherwise specified.

MACHINE DIMENSIONS	Single-Tilt Loader					
	General Purpose 0.76 m <sup>3</sup> (1 yd <sup>3</sup> )		General Purpose 0.96 m <sup>3</sup> (1.25 yd <sup>3</sup> )		Multi Purpose 1.0 m <sup>3</sup> (1.3 yd <sup>3</sup> )	
1) Overall transport length	7233 mm	23'9"	7321 mm	24'0"	7285 mm	23'11"
Overall length	7180 mm	23'7"	7293 mm	23'11"	7209 mm	23'8"
2) Overall transport height	3577 mm	11'9"	3577 mm	11'9"	3577 mm	11'9"
Overall width	2322 mm	7'7"	2322 mm	7'7"	2322 mm	7'7"
3) Height to top of cab/canopy	2819 mm	9'3"	2819 mm	9'3"	2819 mm	9'3"
4) Height to top of exhaust stack	2754 mm	9'0"	2754 mm	9'0"	2754 mm	9'0"
Ground clearance (minimum)	320 mm	1'1"	320 mm	1'1"	320 mm	1'1"
5) Rear axle centerline to front grill	2704 mm	8'10"	2704 mm	8'10"	2704 mm	8'10"
Front wheel tread gauge	1880 mm	6'2"	1880 mm	6'2"	1880 mm	6'2"
Rear wheel tread gauge	1727 mm	5'8"	1727 mm	5'8"	1727 mm	5'8"
6) Wheelbase (2WD/AWD)	2200 mm	7'3"	2200 mm	7'3"	2200 mm	7'3"

LOADER BUCKET DIMENSIONS AND PERFORMANCE	Single-Tilt Loader					
	General Purpose 0.76 m <sup>3</sup> (1 yd <sup>3</sup> )		General Purpose 0.96 m <sup>3</sup> (1.25 yd <sup>3</sup> )		Multi Purpose 1.0 m <sup>3</sup> (1.3 yd <sup>3</sup> )	
Capacity (SAE) rated	0.76 m <sup>3</sup>	<b>1 yd<sup>3</sup></b>	0.96 m <sup>3</sup>	<b>1.25 yd<sup>3</sup></b>	1.0 m <sup>3</sup>	<b>1.3 yd<sup>3</sup></b>
Width	2262 mm	<b>7'5"</b>	2262 mm	<b>7'5"</b>	2279 mm	<b>7'6"</b>
Lift capacity at maximum height	2547 kg	<b>5615 lb</b>	2427 kg	<b>5351 lb</b>	2225 kg	<b>4905 lb</b>
Breakout force	40.9 kN	<b>9185 lbf</b>	38.1 kN	<b>8565 lbf</b>	37.2 kN	<b>8363 lbf</b>
7) Maximum hinge pin height (2WD)	3296 mm	<b>10'10"</b>	3296 mm	<b>10'10"</b>	3296 mm	<b>10'10"</b>
(4WD)	3368 mm	<b>11'1"</b>	3368 mm	<b>11'1"</b>	3368 mm	<b>11'1"</b>
8) Dump angle at full height		<b>44°</b>		<b>44°</b>		<b>44°</b>
Dump height at maximum angle	2651 mm	<b>8'8"</b>	2573 mm	<b>8'5"</b>	2624 mm	<b>8'7"</b>
9) Dump reach at maximum angle	772 mm	<b>2'6"</b>	853 mm	<b>2'6"</b>	761 mm	<b>2'6"</b>
10) Maximum bucket rollback at ground level		<b>39°</b>		<b>39°</b>		<b>40°</b>
11) Digging depth	106 mm	<b>4"</b>	106 mm	<b>4"</b>	133 mm	<b>5"</b>
Maximum grading angle		<b>110°</b>		<b>107°</b>		<b>110°</b>
Width of dozer cutting edge		<b>N/A</b>		<b>N/A</b>	2262 mm	<b>7'5"</b>
12) Grill to bucket cutting edge, carry position	1428 mm	<b>4'8"</b>	1516 mm	<b>5'0"</b>	1480 mm	<b>4'10"</b>
13) Maximum operating height	4063 mm	<b>13'4"</b>	4063 mm	<b>13'4"</b>	4063 mm	<b>13'4"</b>
Jaw opening maximum		<b>N/A</b>		<b>N/A</b>	790 mm	<b>2'7"</b>
Weight (does not include teeth or forks)	384 kg	<b>847 lb</b>	451 kg	<b>994 lb</b>	745 kg	<b>1642 lb</b>

BACKHOE DIMENSIONS AND PERFORMANCE	Standard Stick		Extendible Stick Retracted		Extendible Stick Extended	
	14) Digging depth, SAE (maximum)	4360 mm	<b>14'4"</b>	4402 mm	<b>14'5"</b>	5456 mm
15) Digging depth, 610 mm (2'0") flat bottom	4321 mm	<b>14'2"</b>	4363 mm	<b>14'4"</b>	5420 mm	<b>17'10"</b>
Reach from rear axle centerline at ground line	6721 mm	<b>22'1"</b>	6760 mm	<b>22'2"</b>	7769 mm	<b>25'6"</b>
16) Reach from swing pivot at ground line	5618 mm	<b>18'5"</b>	5657 mm	<b>18'7"</b>	6666 mm	<b>21'10"</b>
Maximum operating height	5523 mm	<b>18'1"</b>	5555 mm	<b>18'3"</b>	6302 mm	<b>20'8"</b>
Loading height	3636 mm	<b>11'11"</b>	3577 mm	<b>11'9"</b>	4145 mm	<b>13'7"</b>
17) Loading reach	1768 mm	<b>5'10"</b>	1868 mm	<b>6'2"</b>	2771 mm	<b>9'1"</b>
Swing arc		<b>180°</b>		<b>180°</b>		<b>180°</b>
Bucket rotation		<b>205°</b>		<b>205°</b>		<b>205°</b>
18) Stabilizer spread, operating position (center of pad)	3310 mm	<b>10'10"</b>	3310 mm	<b>10'10"</b>	3310 mm	<b>10'10"</b>
19) Stabilizer spread, operating position (outside edge of pad)	3770 mm	<b>12'4"</b>	3770 mm	<b>12'4"</b>	3770 mm	<b>12'4"</b>
Stabilizer spread, transport position	2322 mm	<b>7'7"</b>	2322 mm	<b>7'7"</b>	2322 mm	<b>7'7"</b>
Bucket dig force	51.8 kN	<b>11,655 lbf</b>	51.1 kN	<b>11,491 lbf</b>	51.1 kN	<b>11,491 lbf</b>
Stick dig force	31.8 kN	<b>7151 lbf</b>	31.8 kN	<b>7151 lbf</b>	23.4 kN	<b>5250 lbf</b>

# Backhoe Loaders

## Lift Capacities

● 416E

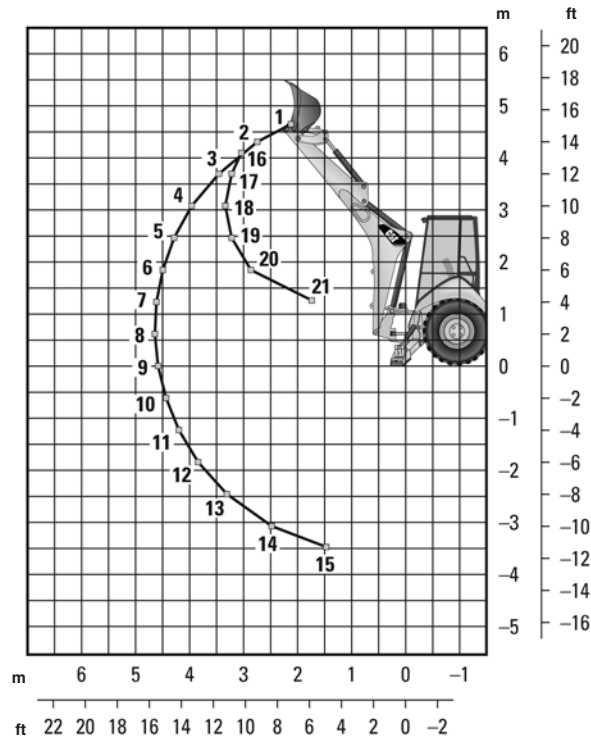

### Standard Stick

#### Boom Lifting

1	1262 kg	2776 lb
2	1378 kg	3031 lb
3	1394 kg	3066 lb
4	1356 kg	2984 lb
5	1306 kg	2873 lb
6	1253 kg	2757 lb
7	1202 kg	2643 lb
8	1153 kg	2536 lb
9	1107 kg	2436 lb
10	1065 kg	2344 lb
11	1028 kg	2261 lb
12	995 kg	2190 lb
13	972 kg	2138 lb
14	973 kg	2141 lb
15	1081 kg	2377 lb

#### Stick Lifting

16	1297 kg	2853 lb
17	1827 kg	4020 lb
18	2195 kg	4828 lb
19	2275 kg	5005 lb
20	2645 kg	5818 lb
21	5285 kg	11,627 lb

Lift Capacities are over-end values. Machine equipped with AWD, OROPS, 0.76 m<sup>3</sup> (1.0 yd<sup>3</sup>) general purpose bucket, and 113 kg (250 lb) counterweight. Extendible stick includes 485 kg (1070 lb) counterweight.

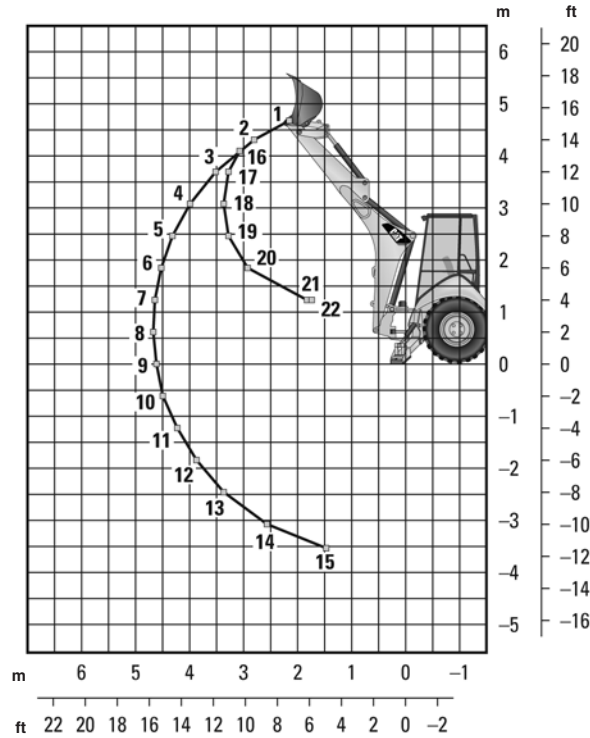

**Extendible Stick Retracted**

Boom Lifting

1	1084 kg	2385 lb
2	1186 kg	2608 lb
3	1190 kg	2618 lb
4	1149 kg	2527 lb
5	1096 kg	2412 lb
6	1042 kg	2291 lb
7	988 kg	2174 lb
8	938 kg	2063 lb
9	890 kg	1958 lb
10	846 kg	1860 lb
11	805 kg	1771 lb
12	768 kg	1690 lb
13	738 kg	1623 lb
14	722 kg	1589 lb
15	788 kg	1734 lb

Stick Lifting

16	1155 kg	2541 lb
17	1672 kg	3679 lb
18	1992 kg	4382 lb
19	2063 kg	4539 lb
20	2395 kg	5269 lb
21	4688 kg	10,313 lb
22	5059 kg	11,129 lb

Lift Capacities are over-end values. Machine equipped with AWD, OROPS, 0.76 m<sup>3</sup> (1.0 yd<sup>3</sup>) general purpose bucket, and 113 kg (250 lb) counterweight. Extendible stick includes 485 kg (1070 lb) counterweight.



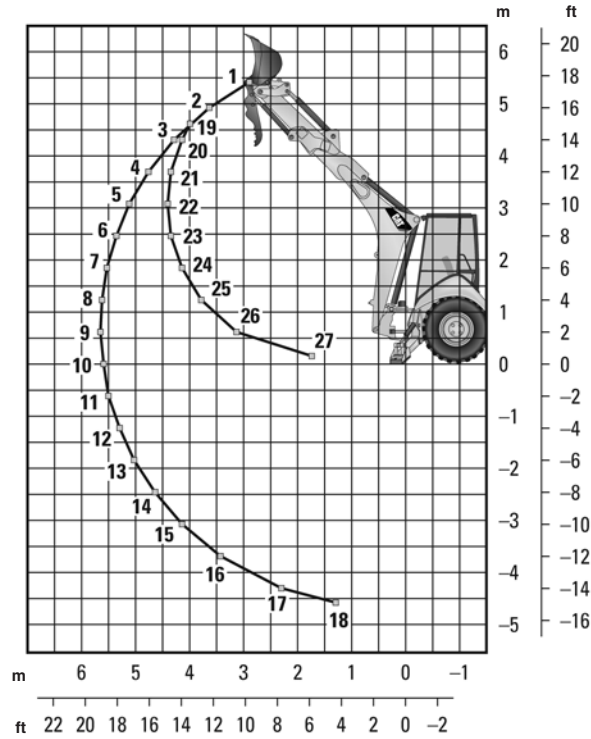

### Extendible Stick Extended

#### Boom Lifting

1	597 kg	1313 lb
2	729 kg	1605 lb
3	780 kg	1715 lb
4	725 kg	1596 lb
5	681 kg	1498 lb
6	659 kg	1449 lb
7	653 kg	1437 lb
8	663 kg	1458 lb
9	687 kg	1512 lb
10	672 kg	1478 lb
11	651 kg	1432 lb
12	632 kg	1390 lb
13	616 kg	1354 lb
14	604 kg	1328 lb
15	600 kg	1319 lb
16	613 kg	1348 lb
17	704 kg	1550 lb
18	1071 kg	2355 lb

#### Stick Lifting

19	543 kg	1195 lb
20	724 kg	1593 lb
21	973 kg	2141 lb
22	1146 kg	2522 lb
23	1290 kg	2839 lb
24	1442 kg	3172 lb
25	1653 kg	3637 lb
26	2160 kg	4751 lb
27	5031 kg	11,069 lb

Lift Capacities are over-end values. Machine equipped with AWD, OROPS, 0.76 m<sup>3</sup> (1.0 yd<sup>3</sup>) general purpose bucket, and 113 kg (250 lb) counterweight. Extendible stick includes 485 kg (1070 lb) counterweight.

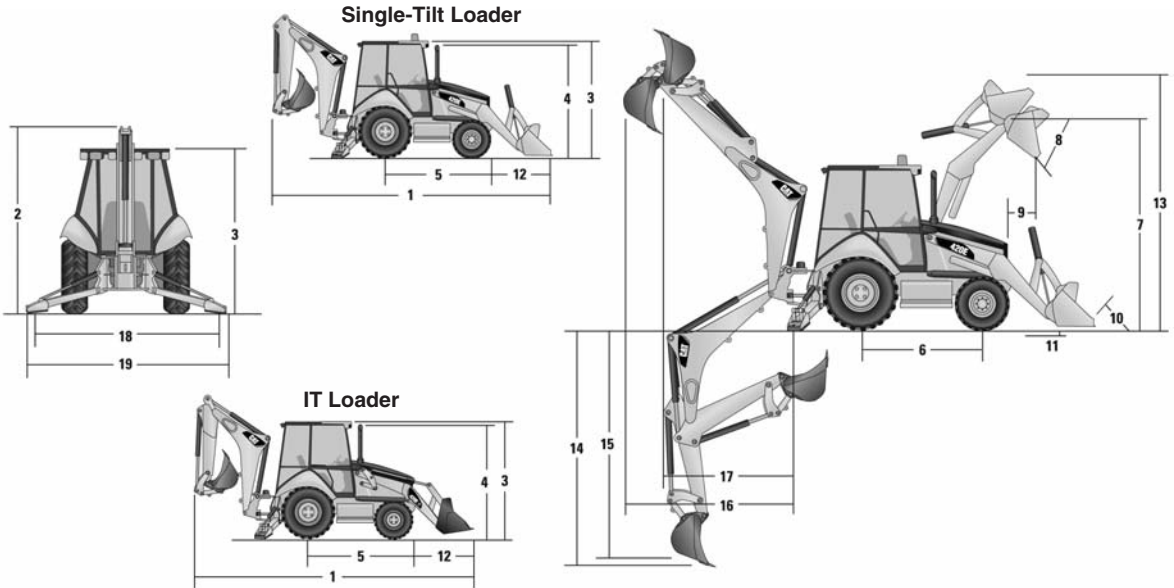

MACHINE DIMENSIONS	Single-Tilt Loader					
	General Purpose 0.96 m <sup>3</sup> (1.25 yd <sup>3</sup> )		General Purpose 1.0 m <sup>3</sup> (1.31 yd <sup>3</sup> )		General Purpose 1.07 m <sup>3</sup> (1.4 yd <sup>3</sup> )	
1) Overall transport length	7343 mm	24'1"	7311 mm	24'0"	7232 mm	23'5"
Overall length	7290 mm	23'11"	7245 mm	23'9"	7227 mm	23'6"
2) Overall transport height	3577 mm	11'9"	3577 mm	11'9"	3577 mm	11'9"
Overall width	2438 mm	8'0"	2438 mm	8'0"	2322 mm	7'7"
3) Height to top of cab/canopy	2819 mm	9'3"	2819 mm	9'3"	2819 mm	9'3"
4) Height to top of exhaust stack	2754 mm	9'0"	2754 mm	9'0"	2754 mm	9'0"
Ground clearance (minimum)	320 mm	1'1"	320 mm	1'1"	320 mm	1'1"
5) Rear axle centerline to front grill	2704 mm	8'10"	2704 mm	8'10"	2705 mm	8'10"
Front wheel tread gauge	1880 mm	6'2"	1880 mm	6'2"	1826 mm	6'0"
Rear wheel tread gauge	1727 mm	5'8"	1727 mm	5'8"	1707 mm	5'7"
6) Wheelbase (2WD/4WD)	2200 mm	7'3"	2200 mm	7'3"	2200 mm	7'3"

MACHINE DIMENSIONS	Single-Tilt Loader							
	Multi Purpose 0.96 m <sup>3</sup> (1.25 yd <sup>3</sup> )		Multi Purpose 1.03 m <sup>3</sup> (1.35 yd <sup>3</sup> )		Multi Purpose with Forks 1.0 m <sup>3</sup> (1.31 yd <sup>3</sup> )		Multi Purpose with Forks 1.07 m <sup>3</sup> (1.4 yd <sup>3</sup> )	
1) Overall transport length	7130 mm	23'5"	7130 mm	23'5"	7130 mm	23'5"	7130 mm	23'5"
Overall length	7155 mm	23'6"	7155 mm	23'6"	7155 mm	23'6"	7155 mm	23'6"
2) Overall transport height	3577 mm	11'9"	3577 mm	11'9"	3577 mm	11'9"	3577 mm	11'9"
Overall width	2322 mm	7'7"	2322 mm	7'7"	2322 mm	7'7"	2322 mm	7'7"
3) Height to top of cab/canopy	2819 mm	9'3"	2819 mm	9'3"	2819 mm	9'3"	2819 mm	9'3"
4) Height to top of exhaust stack	2754 mm	9'0"	2754 mm	9'0"	2754 mm	9'0"	2754 mm	9'0"
Ground clearance (minimum)	320 mm	1'1"	320 mm	1'1"	320 mm	1'1"	320 mm	1'1"
5) Rear axle centerline to front grill	2705 mm	8'10"	2705 mm	8'10"	2705 mm	8'10"	2705 mm	8'10"
Front wheel tread gauge	1826 mm	6'0"	1826 mm	6'0"	1826 mm	6'0"	1826 mm	6'0"
Rear wheel tread gauge	1707 mm	5'7"	1707 mm	5'7"	1707 mm	5'7"	1707 mm	5'7"
6) Wheelbase (2WD/4WD)	2200 mm	7'3"	2200 mm	7'3"	2200 mm	7'3"	2200 mm	7'3"

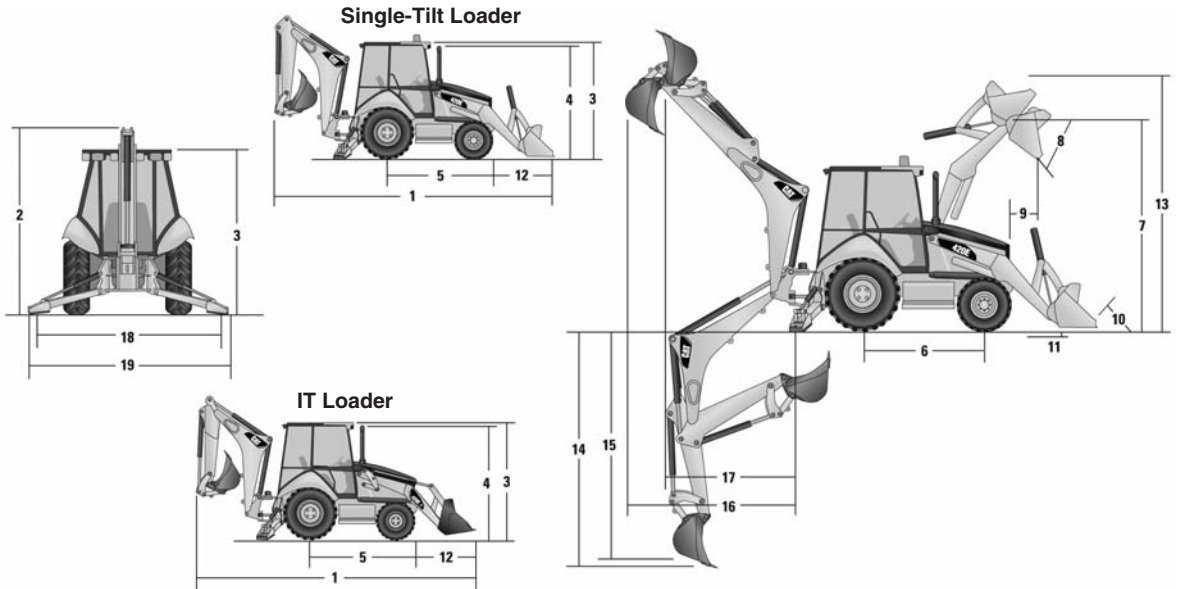

MACHINE DIMENSIONS	IT Loader with Quick Coupler					
	General Purpose 0.96 m <sup>3</sup> (1.25 yd <sup>3</sup> )		General Purpose 1.0 m <sup>3</sup> (1.31 yd <sup>3</sup> )		General Purpose 1.15 m <sup>3</sup> (1.50 yd <sup>3</sup> )	
1) Overall transport length	7434 mm	24'5"	7402 mm	24'3"	7231 mm	23'9"
Overall length	7399 mm	24'3"	7354 mm	24'2"	7275 mm	23'10"
2) Overall transport height	3577 mm	11'9"	3577 mm	11'9"	3577 mm	11'9"
Overall width	2438 mm	8'0"	2438 mm	8'0"	2322 mm	7'7"
3) Height to top of cab/canopy	2819 mm	9'3"	2819 mm	9'3"	2819 mm	9'3"
4) Height to top of exhaust stack	2754 mm	9'0"	2754 mm	9'0"	2754 mm	9'0"
Ground clearance (minimum)	320 mm	1'1"	320 mm	1'1"	320 mm	1'1"
5) Rear axle centerline to front grill	2704 mm	8'10"	2704 mm	8'10"	2705 mm	8'10"
Front wheel tread gauge	1880 mm	6'2"	1880 mm	6'2"	1880 mm	6'2"
Rear wheel tread gauge	1727 mm	5'8"	1727 mm	5'8"	1727 mm	5'8"
6) Wheelbase (2WD/AWD)	2200 mm	7'3"	2200 mm	7'3"	2200 mm	7'3"

MACHINE DIMENSIONS	IT Loader with Quick Coupler			
	Multi Purpose 0.96 m <sup>3</sup> (1.25 yd <sup>3</sup> )		Multi Purpose 1.03 m <sup>3</sup> (1.35 yd <sup>3</sup> )	
1) Overall transport length	7231 mm	23'9"	7231 mm	23'9"
Overall length	7208 mm	23'8"	7208 mm	23'8"
2) Overall transport height	3577 mm	11'9"	3577 mm	11'9"
Overall width	2322 mm	7'7"	2322 mm	7'7"
3) Height to top of cab/canopy	2819 mm	9'3"	2819 mm	9'3"
4) Height to top of exhaust stack	2754 mm	9'0"	2754 mm	9'0"
Ground clearance (minimum)	320 mm	1'1"	320 mm	1'1"
5) Rear axle centerline to front grill	2705 mm	8'10"	2705 mm	8'10"
Front wheel tread gauge	1880 mm	6'2"	1880 mm	6'2"
Rear wheel tread gauge	1727 mm	5'8"	1727 mm	5'8"
6) Wheelbase (2WD/AWD)	2200 mm	7'3"	2200 mm	7'3"

LOADER BUCKET DIMENSIONS AND PERFORMANCE	Single-Tilt Loader							
	General Purpose 0.96 m <sup>3</sup> (1.25 yd <sup>3</sup> )		General Purpose 1.0 m <sup>3</sup> (1.31 yd <sup>3</sup> )		General Purpose 1.07 m <sup>3</sup> (1.4 yd <sup>3</sup> )		General Purpose 1.15 m <sup>3</sup> (1.5 yd <sup>3</sup> )	
Capacity (SAE) rated	0.96 m <sup>3</sup>	<b>1.25 yd<sup>3</sup></b>	1.0 m <sup>3</sup>	<b>1.31 yd<sup>3</sup></b>	1.07 m <sup>3</sup>	<b>1.4 yd<sup>3</sup></b>	1.15 m <sup>3</sup>	<b>1.5 yd<sup>3</sup></b>
Width	2262 mm	<b>7'5"</b>	2406 mm	<b>7'11"</b>	2262 mm	<b>7'5"</b>	2406 mm	<b>7'11"</b>
Lift capacity at maximum height	2929 kg	<b>6457 lb</b>	2937 kg	<b>6475 lb</b>	2868 kg	<b>6323 lb</b>	2733 kg	<b>6025 lb</b>
Breakout force	45.6 kN	<b>10,242 lbf</b>	46.3 kN	<b>10,401 lbf</b>	45.1 kN	<b>10,130 lbf</b>	43.6 kN	<b>9814 lbf</b>
7) Maximum hinge pin height (2WD)	3296 mm	<b>10'10"</b>	3296 mm	<b>10'10"</b>	3296 mm	<b>10'10"</b>	3294 mm	<b>10'10"</b>
(4WD)	3368 mm	<b>11'1"</b>	3368 mm	<b>11'1"</b>	3368 mm	<b>11'1"</b>	3294 mm	<b>10'10"</b>
8) Dump angle at full height	<b>44°</b>		<b>44°</b>		<b>44°</b>		<b>46°</b>	
Dump height at maximum angle	2573 mm	<b>8'5"</b>	2604 mm	<b>8'7"</b>	2550 mm	<b>8'4"</b>	2529 mm	<b>8'4"</b>
9) Dump reach at maximum angle	853 mm	<b>2'10"</b>	821 mm	<b>2'8"</b>	819 mm	<b>2'8"</b>	752 mm	<b>2'6"</b>
10) Maximum bucket rollback at ground level	<b>39°</b>		<b>39°</b>		<b>40°</b>		<b>40°</b>	
11) Digging depth	106 mm	<b>4"</b>	106 mm	<b>4"</b>	146 mm	<b>6"</b>	146 mm	<b>6"</b>
Maximum grading angle	<b>107°</b>		<b>108°</b>		<b>108°</b>		<b>111°</b>	
Width of dozer cutting edge	<b>N/A</b>		<b>N/A</b>		<b>N/A</b>		<b>N/A</b>	
12) Grill to bucket cutting edge, carry position	1516 mm	<b>5'0"</b>	1484 mm	<b>4'10"</b>	1551 mm	<b>5'1"</b>	1544 mm	<b>5'1"</b>
13) Maximum operating height	4196 mm	<b>13'9"</b>	4196 mm	<b>13'9"</b>	4237 mm	<b>13'11"</b>	4216 mm	<b>12'11"</b>
Jaw opening maximum	<b>N/A</b>		<b>N/A</b>		<b>N/A</b>		<b>N/A</b>	
Weight (does not include teeth or forks)	438 kg	<b>967 lb</b>	449 kg	<b>989 lb</b>	459 kg	<b>1012 lb</b>	493 kg	<b>1088 lb</b>

LOADER BUCKET DIMENSIONS AND PERFORMANCE	Single-Tilt Loader							
	Multi Purpose 0.96 m <sup>3</sup> (1.25 yd <sup>3</sup> )		Multi Purpose 1.03 m <sup>3</sup> (1.35 yd <sup>3</sup> )		Multi Purpose with Forks 1.0 m <sup>3</sup> (1.31 yd <sup>3</sup> )		Multi Purpose with Forks 1.07 m <sup>3</sup> (1.4 yd <sup>3</sup> )	
Capacity (SAE) rated	0.96 m <sup>3</sup>	<b>1.25 yd<sup>3</sup></b>	1.03 m <sup>3</sup>	<b>1.35 yd<sup>3</sup></b>	1.0 m <sup>3</sup>	<b>1.31 yd<sup>3</sup></b>	1.07 m <sup>3</sup>	<b>1.4 yd<sup>3</sup></b>
Width	2279 mm	<b>7'6"</b>	2425 mm	<b>7'11"</b>	2279 mm	<b>7'6"</b>	2425 mm	<b>7'11"</b>
Lift capacity at maximum height	2616 kg	<b>5768 lb</b>	2587 kg	<b>5704 lb</b>	2500 kg	<b>5512 lb</b>	2471 kg	<b>5448 lb</b>
Breakout force	46.9 kN	<b>10,547 lbf</b>	46.7 kN	<b>10,514 lbf</b>	46 kN	<b>10,341 lbf</b>	45.8 kN	<b>10,308 lbf</b>
7) Maximum hinge pin height (2WD)	3294 mm	<b>10'10"</b>	3294 mm	<b>10'10"</b>	3294 mm	<b>10'10"</b>	3294 mm	<b>10'10"</b>
(4WD)	3294 mm	<b>10'10"</b>	3294 mm	<b>10'10"</b>	3294 mm	<b>10'10"</b>	3294 mm	<b>10'10"</b>
8) Dump angle at full height	<b>46°</b>		<b>46°</b>		<b>46°</b>		<b>46°</b>	
Dump height at maximum angle	2605 mm	<b>8'7"</b>	2605 mm	<b>8'7"</b>	2605 mm	<b>8'7"</b>	2605 mm	<b>8'7"</b>
9) Dump reach at maximum angle	695 mm	<b>2'3"</b>	695 mm	<b>2'3"</b>	695 mm	<b>2'3"</b>	695 mm	<b>2'3"</b>
10) Maximum bucket rollback at ground level	<b>40°</b>		<b>40°</b>		<b>40°</b>		<b>40°</b>	
11) Digging depth	133 mm	<b>5"</b>	133 mm	<b>5"</b>	133 mm	<b>5"</b>	133 mm	<b>5"</b>
Maximum grading angle	<b>113°</b>		<b>113°</b>		<b>113°</b>		<b>113°</b>	
Width of dozer cutting edge	2262 mm	<b>7'5"</b>	2406 mm	<b>7'11"</b>	2262 mm	<b>7'5"</b>	2262 mm	<b>7'5"</b>
12) Grill to bucket cutting edge, carry position	1473 mm	<b>4'10"</b>	1473 mm	<b>4'10"</b>	1473 mm	<b>4'10"</b>	1473 mm	<b>4'10"</b>
13) Maximum operating height	4224 mm	<b>13'10"</b>	4224 mm	<b>13'10"</b>	4698 mm	<b>15'5"</b>	4698 mm	<b>15'5"</b>
Jaw opening maximum	790 mm	<b>2'7"</b>	790 mm	<b>2'7"</b>	790 mm	<b>2'7"</b>	790 mm	<b>2'7"</b>
Weight (does not include teeth or forks)	745 kg	<b>1642 lb</b>	774 kg	<b>1705 lb</b>	915 kg	<b>2016 lb</b>	936 kg	<b>2064 lb</b>

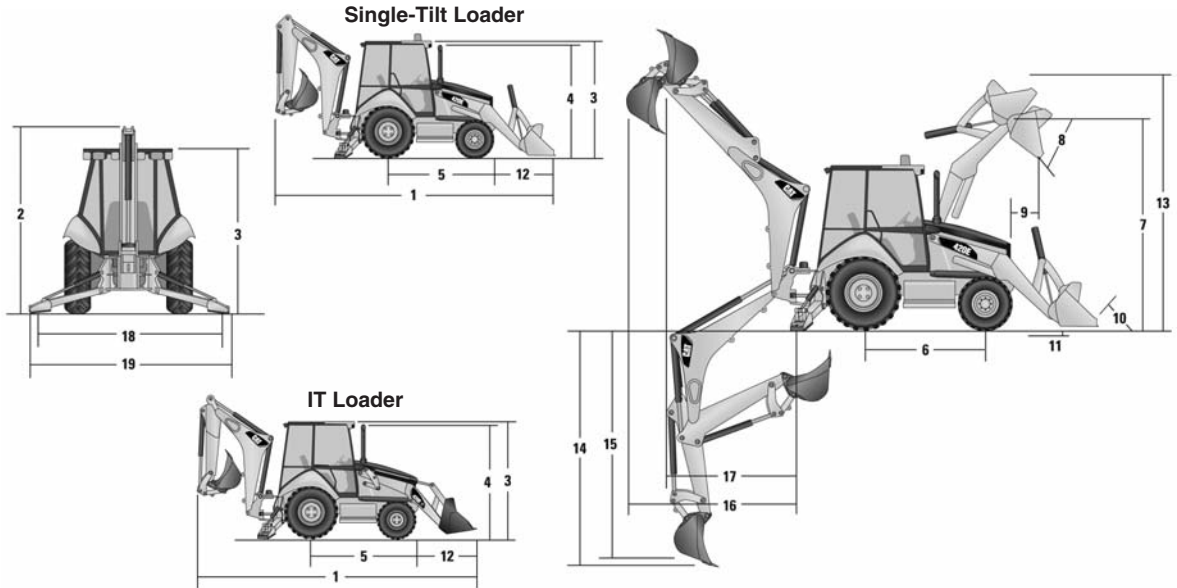

LOADER BUCKET DIMENSIONS AND PERFORMANCE	IT Loader with Quick Coupler					
	General Purpose 0.96 m <sup>3</sup> (1.25 yd <sup>3</sup> )		General Purpose 1.0 m <sup>3</sup> (1.31 yd <sup>3</sup> )		General Purpose 1.15 m <sup>3</sup> (1.5 yd <sup>3</sup> )	
Capacity (SAE) rated	0.96 m <sup>3</sup>	<b>1.25 yd<sup>3</sup></b>	1.0 m <sup>3</sup>	<b>1.31 yd<sup>3</sup></b>	1.15 m <sup>3</sup>	<b>1.5 yd<sup>3</sup></b>
Width	2262 mm	<b>7'5"</b>	2406 mm	<b>7'11"</b>	2406 mm	<b>7'11"</b>
Lift capacity at maximum height	3164 kg	<b>6975 lb</b>	3162 kg	<b>6971 lb</b>	3023 kg	<b>6664 lb</b>
Breakout force	47.1 kN	<b>10,593 lbf</b>	47.5 kN	<b>10,672 lbf</b>	45.5 kN	<b>10,235 lbf</b>
7) Maximum hinge pin height						
(2WD)	3296 mm	<b>10'10"</b>	3296 mm	<b>10'10"</b>	3296 mm	<b>10'10"</b>
(4WD)	3329 mm	<b>10'11"</b>	3329 mm	<b>10'11"</b>	3316 mm	<b>10'11"</b>
8) Dump angle at full height		<b>45°</b>		<b>45°</b>		<b>45°</b>
Dump height at maximum angle	2507 mm	<b>8'2"</b>	2539 mm	<b>8'4"</b>	2493 mm	<b>8'2"</b>
9) Dump reach at maximum angle	831 mm	<b>2'9"</b>	799 mm	<b>2'7"</b>	801 mm	<b>2'8"</b>
10) Maximum bucket rollback at ground level		<b>40°</b>		<b>40°</b>		<b>40°</b>
11) Digging depth	147 mm	<b>6"</b>	147 mm	<b>6"</b>	153 mm	<b>6"</b>
Maximum grading angle		<b>108°</b>		<b>110°</b>		<b>108°</b>
Width of dozer cutting edge		<b>N/A</b>		<b>N/A</b>		<b>N/A</b>
12) Grill to bucket cutting edge, carry position	1607 mm	<b>5'3"</b>	1575 mm	<b>5'2"</b>	1593 mm	<b>5'3"</b>
13) Maximum operating height	4260 mm	<b>14'0"</b>	4256 mm	<b>14'0"</b>	4303 mm	<b>14'1"</b>
Jaw opening maximum		<b>N/A</b>		<b>N/A</b>		<b>N/A</b>
Weight (does not include teeth or forks)	434 kg	<b>957 lb</b>	444 kg	<b>978 lb</b>	481 kg	<b>1060 lb</b>

LOADER BUCKET DIMENSIONS AND PERFORMANCE	IT Loader with Quick Coupler			
	Multi Purpose 0.96 m <sup>3</sup> (1.25 yd <sup>3</sup> )		Multi Purpose 1.03 m <sup>3</sup> (1.35 yd <sup>3</sup> )	
Capacity (SAE) rated	0.96 m <sup>3</sup>	<b>1.25 yd<sup>3</sup></b>	1.03 m <sup>3</sup>	<b>1.35 yd<sup>3</sup></b>
Width	2279 mm	<b>7'6"</b>	2425 mm	<b>7'11"</b>
Lift capacity at maximum height	2800 kg	<b>6174 lb</b>	2771 kg	<b>6110 lb</b>
Breakout force	44.5 kN	<b>10,020 lbf</b>	44.4 kN	<b>9983 lbf</b>
7) Maximum hinge pin height				
(2WD)	3296 mm	<b>10'10"</b>	3296 mm	<b>10'10"</b>
(4WD)	3316 mm	<b>10'11"</b>	4306 mm	<b>14'2"</b>
8) Dump angle at full height		<b>45°</b>		<b>45°</b>
Dump height at maximum angle	2559 mm	<b>8'5"</b>	2559 mm	<b>8'5"</b>
9) Dump reach at maximum angle	748 mm	<b>2'5"</b>	748 mm	<b>2'5"</b>
10) Maximum bucket rollback at ground level		<b>40°</b>		<b>40°</b>
11) Digging depth	144 mm	<b>6"</b>	144 mm	<b>6"</b>
Maximum grading angle		<b>111°</b>		<b>111°</b>
Width of dozer cutting edge	2622 mm	<b>7'5"</b>	2406 mm	<b>7'11"</b>
12) Grill to bucket cutting edge, carry position	1526 mm	<b>5'0"</b>	1526 mm	<b>5'0"</b>
13) Maximum operating height	4306 mm	<b>14'2"</b>	4306 mm	<b>14'2"</b>
Jaw opening maximum	790 mm	<b>2'7"</b>	790 m	<b>2'7"</b>
Weight (does not include teeth or forks)	724 kg	<b>1596 lb</b>	753 kg	<b>1660 lb</b>

BACKHOE DIMENSIONS AND PERFORMANCE	Standard Stick		Extendible Stick Retracted		Extendible Stick Extended	
14) Digging depth, SAE (maximum)	4360 mm	<b>14'4"</b>	4402 mm	<b>14'5"</b>	5456 mm	<b>17'11"</b>
15) Digging depth, 610 mm (2'0") flat bottom	4321 mm	<b>14'2"</b>	4363 mm	<b>14'4"</b>	5420 mm	<b>17'9"</b>
Reach from rear axle centerline at ground line	6721 mm	<b>22'1"</b>	6760 mm	<b>22'2"</b>	7769 mm	<b>25'6"</b>
16) Reach from swing pivot at ground line	5618 mm	<b>18'5"</b>	5657 mm	<b>18'7"</b>	6666 mm	<b>21'10"</b>
Maximum operating height	5523 mm	<b>18'1"</b>	5555 mm	<b>18'3"</b>	6302 mm	<b>20'8"</b>
Loading height	3636 mm	<b>11'11"</b>	3577 mm	<b>11'9"</b>	4145 mm	<b>13'7"</b>
17) Loading reach	1768 mm	<b>5'10"</b>	1868 mm	<b>6'2"</b>	2771 mm	<b>9'1"</b>
Swing arc		<b>180°</b>		<b>180°</b>		<b>180°</b>
Bucket rotation		<b>205°</b>		<b>205°</b>		<b>205°</b>
18) Stabilizer spread, operating position (center of pad)	3310 mm	<b>10'10"</b>	3310 mm	<b>10'10"</b>	3310 mm	<b>10'10"</b>
19) Stabilizer spread, operating position (outside edge of pad)	3770 mm	<b>12'4"</b>	3770 mm	<b>12'4"</b>	3770 mm	<b>12'4"</b>
Stabilizer spread, transport position	2322 mm	<b>7'7"</b>	2322 mm	<b>7'7"</b>	2322 mm	<b>7'7"</b>
Bucket dig force	61.7 kN	<b>13,875 lbf</b>	60.9 kN	<b>13,863 lbf</b>	60.9 kN	<b>13,863 lbf</b>
Stick dig force	43.0 kN	<b>9662 lbf</b>	42.8 kN	<b>9616 lbf</b>	31.2 kN	<b>7023 lbf</b>

DIMENSIONS WITH FORKS/ MATERIAL-HANDLING ARM	Cat 420E IT Operating Specifications with Forks					
	1070 mm (3'6")		1220 mm (4'0")		1370 mm (4'6")	
Fork Tine Length						
Operating load (SAE J1197)	2291 kg*	<b>5051 lb*</b>	2215 kg*	<b>4883 lb*</b>	2019 kg*	<b>4451 lb*</b>
SAE load center	535 mm	<b>1'9"</b>	610 mm	<b>2'0"</b>	685 mm	<b>2'3"</b>
Operating load (CEN 474-4)	2428 kg	<b>5353 lb</b>	2406 kg	<b>5304 lb</b>	2382 kg	<b>5251 lb</b>
CEN load center	500 mm	<b>1'8"</b>	500 mm	<b>1'8"</b>	500 mm	<b>1'8"</b>
Overall length (A) (forks on ground)	7717 mm	<b>25'4"</b>	7867 mm	<b>25'10"</b>	8017 mm	<b>26'4"</b>

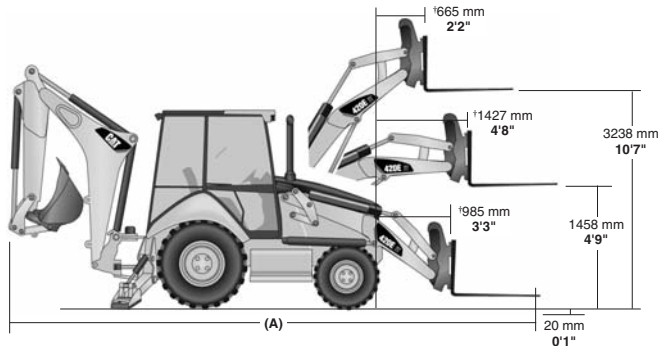

\*Tip limited.  
†Measured from nose of machine.

DIMENSIONS WITH FORKS/ MATERIAL-HANDLING ARM	Cat 420E IT Operating Specifications with Material Handling Arm					
	Retracted		Mid-Position		Extended	
Material-Handling Arm Position						
Operating load (SAE J1197 and CEN 474-4)	933 kg**	<b>2057 lb**</b>	590 kg**	<b>1301 lb**</b>	431 kg**	<b>950 lb**</b>
Overall length, maximum	8809 mm	<b>28'11"</b>	9807 mm	<b>32'2"</b>	10 807 mm	<b>35'5"</b>

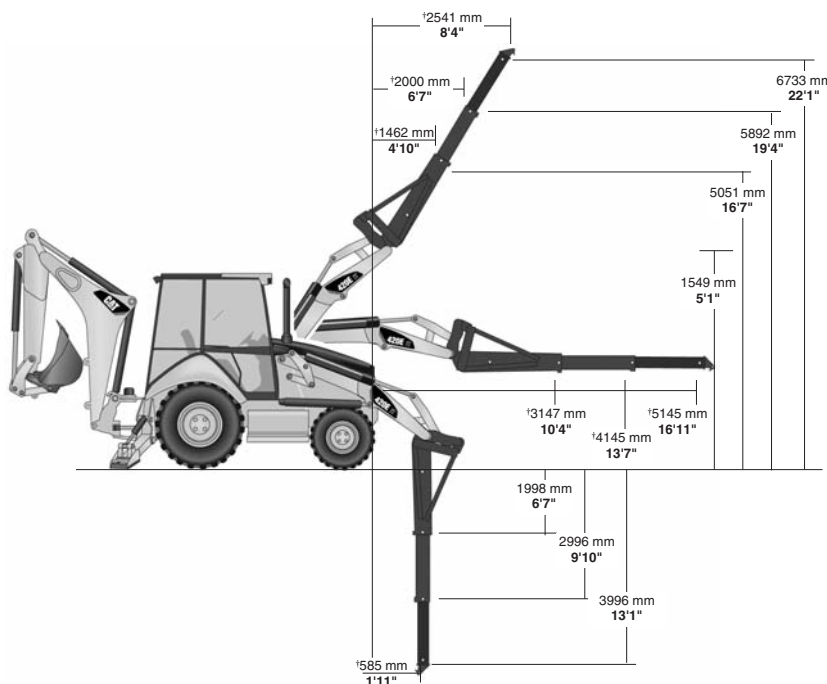

\*\*Hydraulically limited.  
Dimensions and performance specifications shown are for 4WD machines equipped with 12.5/80-18 SGL front tires, 19.5L-24 IT525 rear tires, ROPS canopy, standard stick with 610 mm (24 in) standard duty bucket, and 0.96 m<sup>3</sup> (1.25 yd<sup>3</sup>) loader bucket and standard equipment unless otherwise specified.  
†Measured from nose of machine.

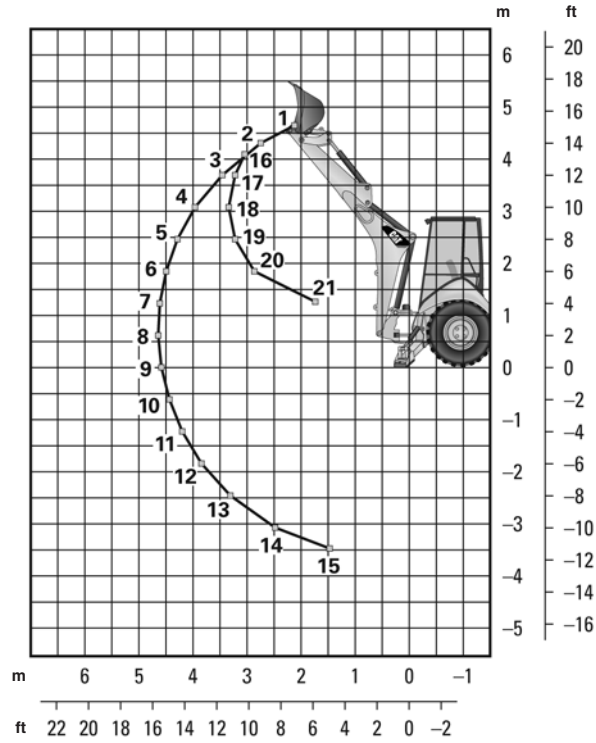

**Standard Stick**

Boom Lifting

1	1585 kg	3494 lb
2	1733 kg	3821 lb
3	1759 kg	3879 lb
4	1718 kg	3787 lb
5	1659 kg	3657 lb
6	1597 kg	3520 lb
7	1536 kg	3385 lb
8	1478 kg	3258 lb
9	1424 kg	3139 lb
10	1375 kg	3031 lb
11	1331 kg	2935 lb
12	1295 kg	2854 lb
13	1270 kg	2800 lb
14	1280 kg	2822 lb
15	1439 kg	3173 lb

Stick Lifting

16	1818 kg	4007 lb
17	2537 kg	5592 lb
18	2472 kg	5450 lb
19	2563 kg	5649 lb
20	2975 kg	6559 lb
21	5920 kg	13,050 lb

Lift Capacities are over-end values. Machine equipped with AWD, OROPS, 0.96 m<sup>3</sup> (1.25 yd<sup>3</sup>) general purpose bucket, and 113 kg (250 lb) counterweight. Extendible stick includes 485 kg (1070 lb) counterweight.



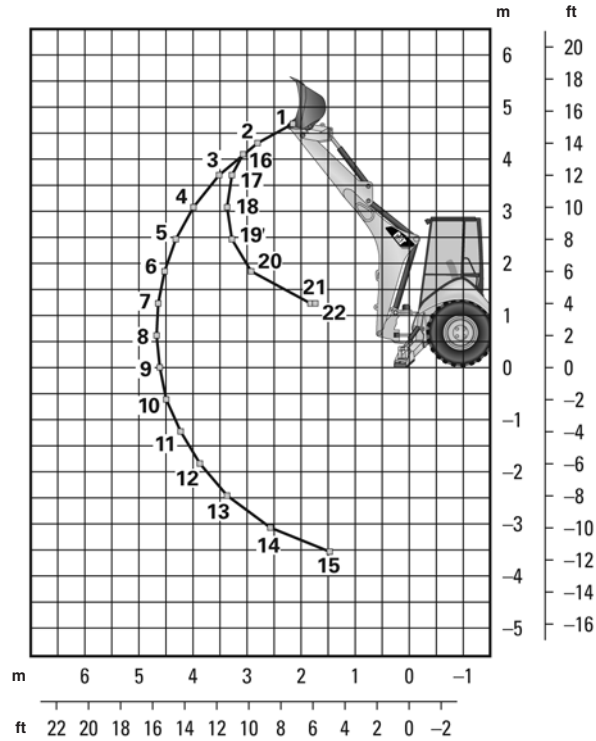

### Extendible Stick Retracted

#### Boom Lifting

1	1405 kg	3097 lb
2	1543 kg	3402 lb
3	1560 kg	3439 lb
4	1516 kg	3342 lb
5	1456 kg	3210 lb
6	1393 kg	3071 lb
7	1331 kg	2935 lb
8	1273 kg	2805 lb
9	1218 kg	2684 lb
10	1167 kg	2572 lb
11	1121 kg	2471 lb
12	1081 kg	2383 lb
13	1051 kg	2316 lb
14	1046 kg	2306 lb
15	1177 kg	2595 lb

#### Stick Lifting

16	1664 kg	3668 lb
17	2366 kg	5217 lb
18	2273 kg	5012 lb
19	2355 kg	5192 lb
20	2728 kg	6015 lb
21	5294 kg	11,671 lb
22	5716 kg	12,602 lb

Lift Capacities are over-end values. Machine equipped with AWD, OROPS, 0.96 m<sup>3</sup> (1.25 yd<sup>3</sup>) general purpose bucket, and 113 kg (250 lb) counterweight. Extendible stick includes 485 kg (1070 lb) counterweight.

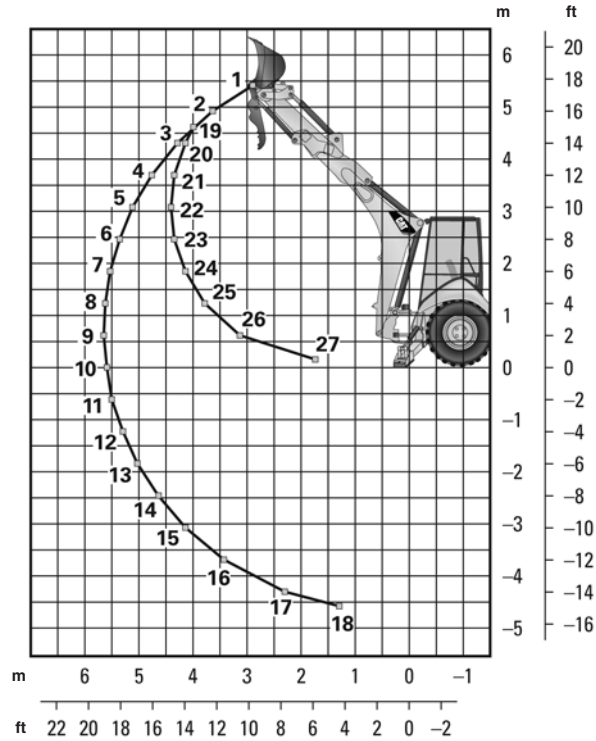

**Extendible Stick Extended**

Boom Lifting

1	816 kg	1800 lb
2	987 kg	2176 lb
3	1055 kg	2326 lb
4	1069 kg	2358 lb
5	1061 kg	2340 lb
6	1041 kg	2294 lb
7	1020 kg	2248 lb
8	994 kg	2192 lb
9	968 kg	2135 lb
10	943 kg	2080 lb
11	920 kg	2029 lb
12	900 kg	1983 lb
13	883 kg	1946 lb
14	872 kg	1922 lb
15	872 kg	1922 lb
16	896 kg	1976 lb
17	1030 kg	2272 lb
18	1555 kg	3429 lb

Stick Lifting

19	859 kg	1893 lb
20	1104 kg	2434 lb
21	1443 kg	3181 lb
22	1547 kg	3410 lb
23	1572 kg	3466 lb
24	1673 kg	3687 lb
25	1899 kg	4185 lb
26	2467 kg	5438 lb
27	5685 kg	12,534 lb

Lift Capacities are over-end values. Machine equipped with AWD, OROPS, 0.96 m<sup>3</sup> (1.25 yd<sup>3</sup>) general purpose bucket, and 113 kg (250 lb) counterweight. Extendible stick includes 485 kg (1070 lb) counterweight.

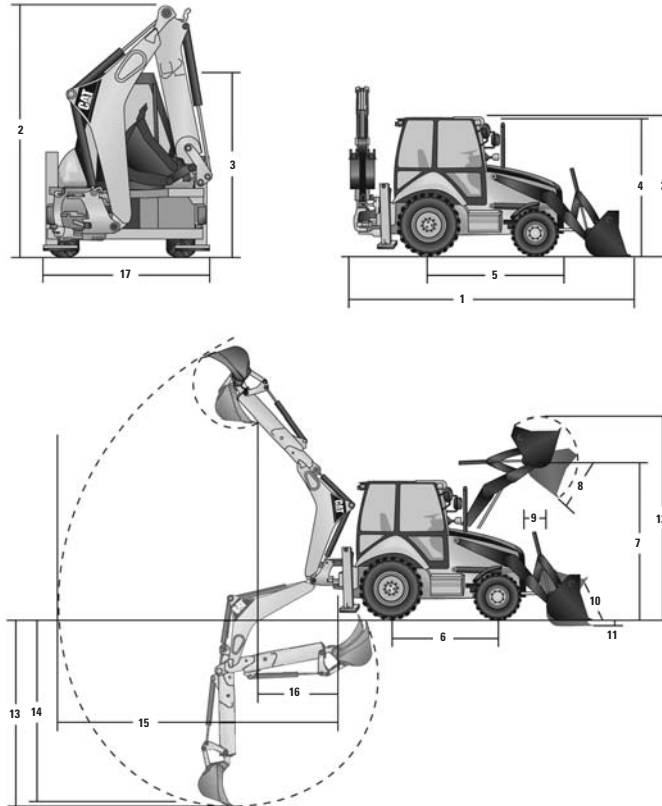

MACHINE DIMENSIONS	General Purpose		Multi Purpose		Multi Purpose with Forks	
	mm	ft"	mm	ft"	mm	ft"
1) Overall length (loader on ground) S-Stick	5785 mm	19'0"	5729 mm	18'10"	5729 mm	18'10"
	5788 mm	19'0"	5732 mm	18'10"	5732 mm	18'10"
Overall length (loader on ground) E-Stick	5830 mm	19'1"	5801 mm	19'0"	5801 mm	19'0"
	5833 mm	19'2"	5804 mm	19'1"	5804 mm	19'1"
2) Overall transport length S-Stick	3736 mm	12'2"	3736 mm	12'2"	3736 mm	12'2"
	3759 mm	12'4"	3759 mm	12'4"	3759 mm	12'4"
Overall transport length E-Stick	2368 mm	7'7"	2368 mm	7'7"	2368 mm	7'7"
	2368 mm	7'7"	2368 mm	7'7"	2368 mm	7'7"
3) Height to top of cab/canopy	2863 mm	9'3"	2863 mm	9'3"	2863 mm	9'3"
4) Height to top of exhaust stack	2779 mm	9'1"	2779 mm	9'1"	2779 mm	9'1"
	459 mm	1'6"	470 mm	1'7"	470 mm	1'7"
	358 mm	1'1"	358 mm	1'1"	358 mm	1'1"
5) Rear axle centerline to front grill	2704 mm	8'8"	2704 mm	8'8"	2704 mm	8'8"
	1826 mm	5'10"	1826 mm	5'10"	1826 mm	5'10"
	1713 mm	5'7"	1713 mm	5'7"	1713 mm	5'7"
6) Wheelbase (AWD)	2200 mm	7'3"	2200 mm	7'3"	2200 mm	7'3"

LOADER BUCKET DIMENSIONS AND PERFORMANCE	General Purpose		Multi Purpose		Multi Purpose with Forks	
	Capacity (SAE) rated	1.0 m <sup>3</sup>	<b>1.30 yd<sup>3</sup></b>	1.03 m <sup>3</sup>	<b>1.34 yd<sup>3</sup></b>	1.03 m <sup>3</sup>
Width	2406 mm	<b>7'11"</b>	2406 mm	<b>7'11"</b>	2406 mm	<b>7'11"</b>
Lift capacity at maximum height	2454 kg	<b>5410 lb</b>	2581 kg	<b>5690 lb</b>	2192 kg	<b>4833 lb</b>
Breakout force	39 kN	<b>8768 lbf</b>	39 kN	<b>8768 lbf</b>	37 kN	<b>8318 lbf</b>
Tipping load at bucket load point	5630 kg	<b>12,412 lb</b>	5980 kg	<b>13,183 lb</b>	5617 kg	<b>12,383 lb</b>
7) Maximum hinge pin height	3314 mm	<b>10'10"</b>	3314 mm	<b>10'10"</b>	3314 mm	<b>10'10"</b>
8) Dump angle at full height		<b>44°</b>		<b>44°</b>		<b>44°</b>
Dump height at maximum angle	2621 mm	<b>8'7"</b>	2653 mm	<b>8'8"</b>	2653 mm	<b>8'8"</b>
9) Dump reach at maximum angle	843 mm	<b>2'9"</b>	770 mm	<b>2'6"</b>	770 mm	<b>2'6"</b>
10) Maximum bucket rollback at ground level		<b>38°</b>		<b>38°</b>		<b>38°</b>
11) Digging depth	91 mm	<b>4"</b>	118 mm	<b>5"</b>	118 mm	<b>5"</b>
Maximum grading angle		<b>109°</b>		<b>112°</b>		<b>112°</b>
Width of dozer cutting edge		<b>N/A</b>	2406 mm	<b>7'11"</b>	2406 mm	<b>7'11"</b>
12) Maximum operating height	4211 mm	<b>13'10"</b>	4238 mm	<b>13'11"</b>	4691 mm	<b>15'5"</b>
Jaw opening maximum		<b>N/A</b>	790 mm	<b>2'7"</b>	790 mm	<b>2'7"</b>
Bucket jaw clamping force		<b>N/A</b>	56 kN	<b>12,589 lbf</b>	56 kN	<b>12,589 lbf</b>
Weight (does not include teeth or forks)	441 kg	<b>972 lb</b>	605 kg	<b>1334 lb</b>	808 kg	<b>1781 lb</b>

BACKHOE DIMENSIONS AND PERFORMANCE	Standard Stick		Extendible Stick Retracted		Extendible Stick Extended	
	13) Digging depth, manufacturers maximum	4952 mm	<b>16'3"</b>	4937 mm	<b>16'2"</b>	5881 mm
14) Digging depth, 610 mm (2'0") flat bottom	4884 mm	<b>16'0"</b>	4897 mm	<b>16'1"</b>	5845 mm	<b>19'2"</b>
15) Reach from swing pivot at ground line	5648 mm	<b>18'6"</b>	5653 mm	<b>18'7"</b>	6579 mm	<b>21'7"</b>
Loading height	3844 mm	<b>12'7"</b>	3938 mm	<b>12'11"</b>	4480 mm	<b>14'8"</b>
16) Loading reach	1679 mm	<b>5'6"</b>	1601 mm	<b>5'3"</b>	2505 mm	<b>8'3"</b>
Swing arc		<b>180°</b>		<b>180°</b>		<b>180°</b>
Bucket rotation		<b>205°</b>		<b>205°</b>		<b>205°</b>
17) Stabilizer width	2368 mm	<b>7'9"</b>	2368 mm	<b>7'9"</b>	2368 mm	<b>7'9"</b>
Bucket dig force	63 kN	<b>14,163 lbf</b>	63 kN	<b>14,163 lbf</b>	63 kN	<b>14,163 lbf</b>
Stick dig force	35 kN	<b>7868 lbf</b>	36 kN	<b>8093 lbf</b>	26 kN	<b>5845 lbf</b>
Total side shift travel	1258 mm	<b>4'2"</b>	1258 mm	<b>4'2"</b>	1258 mm	<b>4'2"</b>

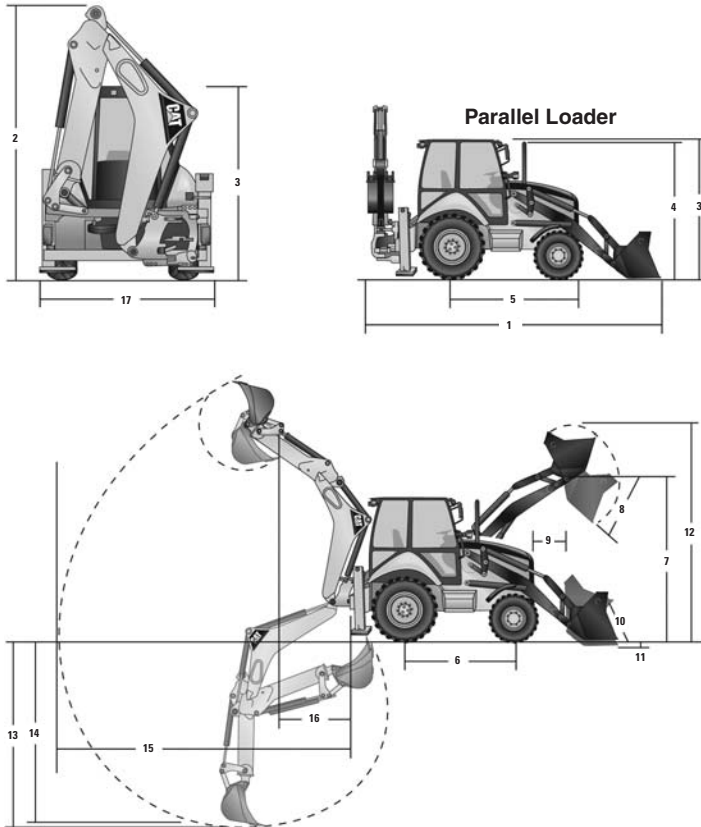

MACHINE DIMENSIONS	General Purpose		Multi Purpose		Multi Purpose with Forks	
	mm	ft"	mm	ft"	mm	ft"
1) Overall length (loader on ground) S-Stick	5855 mm	19'3"	5799 mm	19'0"	5799 mm	19'0"
	5855 mm	19'3"	5799 mm	19'0"	5799 mm	19'0"
Overall length (loader on ground) E-Stick	5881 mm	19'4"	5856 mm	19'3"	5856 mm	19'3"
	5881 mm	19'4"	5856 mm	19'3"	5856 mm	19'3"
2) Overall transport length S-Stick	3736 mm	12'3"	3736 mm	12'3"	3736 mm	12'3"
	3736 mm	12'3"	3736 mm	12'3"	3736 mm	12'3"
Overall transport length E-Stick	2368 mm	7'9"	2368 mm	7'9"	2368 mm	7'9"
	2242 mm	7'4"	2242 mm	7'4"	2242 mm	7'4"
3) Height to top of cab/canopy	2863 mm	9'5"	2863 mm	9'5"	2863 mm	9'5"
	2779 mm	9'1"	2779 mm	9'1"	2779 mm	9'1"
4) Height to top of exhaust stack	403 mm	1'4"	429 mm	1'5"	429 mm	1'5"
	358 mm	1'2"	358 mm	1'2"	358 mm	1'2"
5) Rear axle centerline to front grill	2704 mm	8'10"	2704 mm	8'10"	2704 mm	8'10"
	1915 mm	6'3"	1915 mm	6'3"	1915 mm	6'3"
Rear wheel tread gauge	1713 mm	5'7"	1713 mm	5'7"	1713 mm	5'7"
	2200 mm	7'3"	2200 mm	7'3"	2200 mm	7'3"
6) Wheelbase (AWD)						

LOADER BUCKET DIMENSIONS AND PERFORMANCE	Standard Frame					
	General Purpose		Multi Purpose		Multi Purpose with Forks	
	Capacity (SAE) rated	1.0 m <sup>3</sup>	<b>1.30 yd<sup>3</sup></b>	1.03 m <sup>3</sup>	<b>1.34 yd<sup>3</sup></b>	1.03 m <sup>3</sup>
Width	2406 mm	<b>7'11"</b>	2406 mm	<b>7'11"</b>	2406 mm	<b>7'11"</b>
Lift capacity at maximum height	3322 kg	<b>7324 lb</b>	3069 kg	<b>6766 lb</b>	2899 kg	<b>6391 lb</b>
Breakout force	55 kN	<b>12,364 lbf</b>	61 kN	<b>13,713 lbf</b>	60 kN	<b>13,489 lbf</b>
Tipping load at bucket load point	5664 kg	<b>12,487 lb</b>	5655 kg	<b>12,467 lb</b>	5504 kg	<b>12,134 lb</b>
7) Maximum hinge pin height	3290 mm	<b>10'10"</b>	3290 mm	<b>10'10"</b>	3290 mm	<b>10'10"</b>
8) Dump angle at full height		<b>47°</b>		<b>47°</b>		<b>47°</b>
Dump height at maximum angle	2574 mm	<b>8'5"</b>	2610 mm	<b>8'7"</b>	2610 mm	<b>8'7"</b>
9) Dump reach at maximum angle	743 mm	<b>2'5"</b>	671 mm	<b>2'2"</b>	671 mm	<b>2'2"</b>
10) Maximum bucket rollback at ground level		<b>44°</b>		<b>45°</b>		<b>45°</b>
11) Digging depth	138 mm	<b>5"</b>	166 mm	<b>7"</b>	166 mm	<b>7"</b>
Maximum grading angle		<b>112°</b>		<b>115°</b>		<b>115°</b>
Width of dozer cutting edge		<b>N/A</b>	2406 mm	<b>7'11"</b>	2406 mm	<b>7'11"</b>
12) Maximum operating height	4107 mm	<b>13'6"</b>	4125 mm	<b>13'6"</b>	4125 mm	<b>13'6"</b>
Jaw opening maximum		<b>N/A</b>	790 mm	<b>2'7"</b>	790 mm	<b>2'7"</b>
Bucket jaw clamping force		<b>N/A</b>	56 kN	<b>12,589 lbf</b>	56 kN	<b>12,589 lbf</b>
Weight (does not include teeth or forks)	428 kg	<b>944 lb</b>	611 kg	<b>1347 lb</b>	844 kg	<b>1861 lb</b>

LOADER BUCKET DIMENSIONS AND PERFORMANCE	Narrow Frame					
	General Purpose		Multi Purpose		Multi Purpose with Forks	
	Capacity (SAE) rated	1.0 m <sup>3</sup>	<b>1.30 yd<sup>3</sup></b>	1.03 m <sup>3</sup>	<b>1.34 yd<sup>3</sup></b>	1.03 m <sup>3</sup>
Width	2406 mm	<b>7'11"</b>	2406 mm	<b>7'11"</b>	2406 mm	<b>7'11"</b>
Lift capacity at maximum height	3412 kg	<b>7522 lb</b>	3315 kg	<b>7308 lb</b>	3153 kg	<b>6951 lb</b>
Breakout force	55 kN	<b>12,364 lbf</b>	60 kN	<b>13,489 lbf</b>	60 kN	<b>13,489 lbf</b>
Tipping Load at bucket load point	6577 kg	<b>14,500 lb</b>	6427 kg	<b>14,169 lb</b>	6302 kg	<b>13,894 lb</b>
7) Maximum hinge pin height	3073 mm	<b>10'1"</b>	3073 mm	<b>10'1"</b>	3073 mm	<b>10'1"</b>
8) Dump angle at full height		<b>53°</b>		<b>53°</b>		<b>53°</b>
Dump height at maximum angle	2275 mm	<b>7'6"</b>	2355 mm	<b>7'9"</b>	2355 mm	<b>7'9"</b>
9) Dump reach at maximum angle	885 mm	<b>2'11"</b>	789 mm	<b>2'7"</b>	789 mm	<b>2'7"</b>
10) Maximum bucket rollback at ground level		<b>56°</b>		<b>56°</b>		<b>56°</b>
11) Digging depth	202 mm	<b>8"</b>	230 mm	<b>9"</b>	230 mm	<b>9"</b>
Maximum grading angle		<b>111°</b>		<b>115°</b>		<b>115°</b>
Width of dozer cutting edge		<b>N/A</b>	2406 mm	<b>7'11"</b>	2406 mm	<b>7'11"</b>
12) Maximum operating height	3915 mm	<b>12'10"</b>	3907 mm	<b>12'10"</b>	3907 mm	<b>12'10"</b>
Jaw opening maximum		<b>N/A</b>	790 mm	<b>2'7"</b>	790 mm	<b>2'7"</b>
Bucket jaw clamping force		<b>N/A</b>	56 kN	<b>12,589 lbf</b>	56 kN	<b>12,589 lbf</b>
Weight (does not include teeth or forks)	428 kg	<b>944 lb</b>	611 kg	<b>1347 lb</b>	844 kg	<b>1861 lb</b>

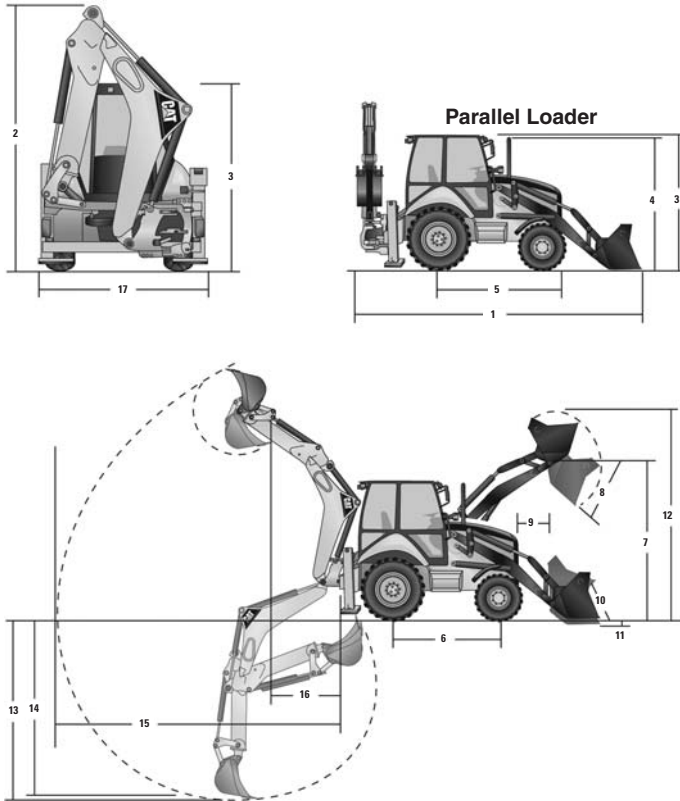

<b>BACKHOE DIMENSIONS AND PERFORMANCE</b>	<b>Standard Stick</b>		<b>Extendible Stick Retracted</b>		<b>Extendible Stick Extended</b>	
13) Digging depth, manufacturers maximum	4913 mm	16'1"	4914 mm	16'1"	5853 mm	19'2"
14) Digging depth, 610 mm (2'0") flat bottom	4872 mm	16'0"	4874 mm	16'0"	5792 mm	19'0"
15) Reach from swing pivot at ground line	5652 mm	18'7"	5657 mm	18'7"	6583 mm	21'7"
Loading height	3819 mm	12'6"	3914 mm	12'10"	4458 mm	14'8"
16) Loading reach	1743 mm	5'9"	1661 mm	5'5"	2560 mm	8'5"
Swing arc	180°		180°		180°	
Bucket rotation	205°		205°		205°	
17) Stabilizer width	2368 mm	7'9"	2368 mm	7'9"	2368 mm	7'9"
Bucket dig force	63 kN	14,163 lbf	63 kN	14,163 lbf	63 kN	14,163 lbf
Stick dig force	35 kN	7868 lbf	36 kN	8093 lbf	26 kN	5845 lbf
Total side shift travel (Standard frame)	1258 mm	4'2"	1258 mm	4'2"	1258 mm	4'2"
Total side shift travel (Narrow frame)	1096 mm	3'7"	1096 mm	3'7"	1096 mm	3'7"

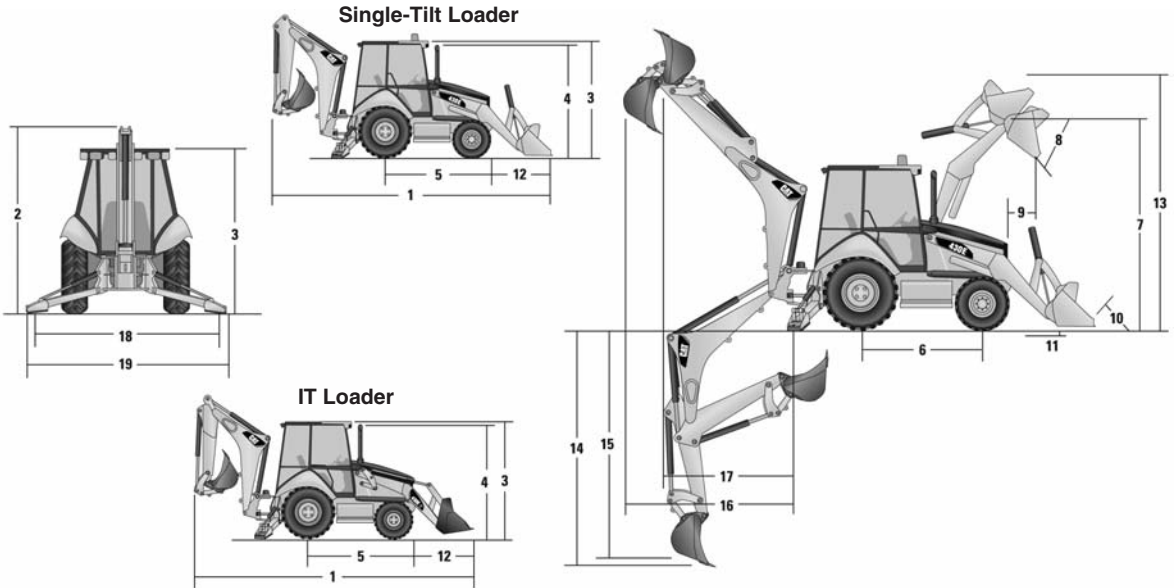

MACHINE DIMENSIONS	Single-Tilt Loader							
	General Purpose 0.96 m <sup>3</sup> (1.25 yd <sup>3</sup> )		General Purpose 1.0 m <sup>3</sup> (1.31 yd <sup>3</sup> )		General Purpose 1.07 m <sup>3</sup> (1.4 yd <sup>3</sup> )		General Purpose 1.15 m <sup>3</sup> (1.5 yd <sup>3</sup> )	
1) Overall transport length	7355 mm	24'2"	7303 mm	24'0"	7366 mm	24'2"	7366 mm	24'2"
Overall length	7332 mm	24'1"	7356 mm	24'2"	7424 mm	24'4"	7424 mm	24'4"
2) Overall transport height	3577 mm	11'9"	3866 mm	12'8"	3866 mm	12'8"	3866 mm	12'8"
Overall width	2322 mm	7'7"	2322 mm	7'7"	2322 mm	7'7"	2322 mm	7'7"
3) Height to top of cab/canopy	2819 mm	9'3"	2819 mm	9'3"	2819 mm	9'3"	2819 mm	9'3"
4) Height to top of exhaust stack	2754 mm	9'0"	2754 mm	9'0"	2754 mm	9'0"	2754 mm	9'0"
Ground clearance (minimum)	320 mm	1'1"	320 mm	1'1"	320 mm	1'1"	320 mm	1'1"
5) Rear axle centerline to front grill	2705 mm	8'10"	2705 mm	8'10"	2705 mm	8'10"	2705 mm	8'10"
Front wheel tread gauge	1880 mm	6'2"	1880 mm	6'2"	1880 mm	6'2"	1880 mm	6'2"
Rear wheel tread gauge	1727 mm	5'8"	1727 mm	5'8"	1727 mm	5'8"	1727 mm	5'8"
6) Wheelbase (2WD/AWD)	2200 mm	7'3"	2200 mm	7'3"	2200 mm	7'3"	2200 mm	7'3"

MACHINE DIMENSIONS	Single-Tilt Loader							
	Multi Purpose 0.96 m <sup>3</sup> (1.25 yd <sup>3</sup> )		Multi Purpose 1.03 m <sup>3</sup> (1.35 yd <sup>3</sup> )		Multi Purpose with Forks 1.0 m <sup>3</sup> (1.31 yd <sup>3</sup> )		Multi Purpose with Forks 1.07 m <sup>3</sup> (1.4 yd <sup>3</sup> )	
1) Overall transport length	7271 mm	23'10"	7271 mm	23'10"	7271 mm	23'10"	7271 mm	23'10"
Overall length	7296 mm	23'11"	7296 mm	23'11"	7296 mm	23'11"	7296 mm	23'11"
2) Overall transport height	3577 mm	11'9"	3577 mm	11'9"	3577 mm	11'9"	3577 mm	11'9"
Overall width	2322 mm	7'7"	2322 mm	7'7"	2322 mm	7'7"	2322 mm	7'7"
3) Height to top of cab/canopy	2819 mm	9'3"	2819 mm	9'3"	2819 mm	9'3"	2819 mm	9'3"
4) Height to top of exhaust stack	2754 mm	9'0"	2754 mm	9'0"	2754 mm	9'0"	2754 mm	9'0"
Ground clearance (minimum)	320 mm	1'1"	320 mm	1'1"	320 mm	1'1"	320 mm	1'1"
5) Rear axle centerline to front grill	2705 mm	8'10"	2705 mm	8'10"	2705 mm	8'10"	2705 mm	8'10"
Front wheel tread gauge	1880 mm	6'2"	1880 mm	6'2"	1880 mm	6'2"	1880 mm	6'2"
Rear wheel tread gauge	1727 mm	5'8"	1727 mm	5'8"	1727 mm	5'8"	1727 mm	5'8"
6) Wheelbase (2WD/AWD)	2200 mm	7'3"	2200 mm	7'3"	2200 mm	7'3"	2200 mm	7'3"



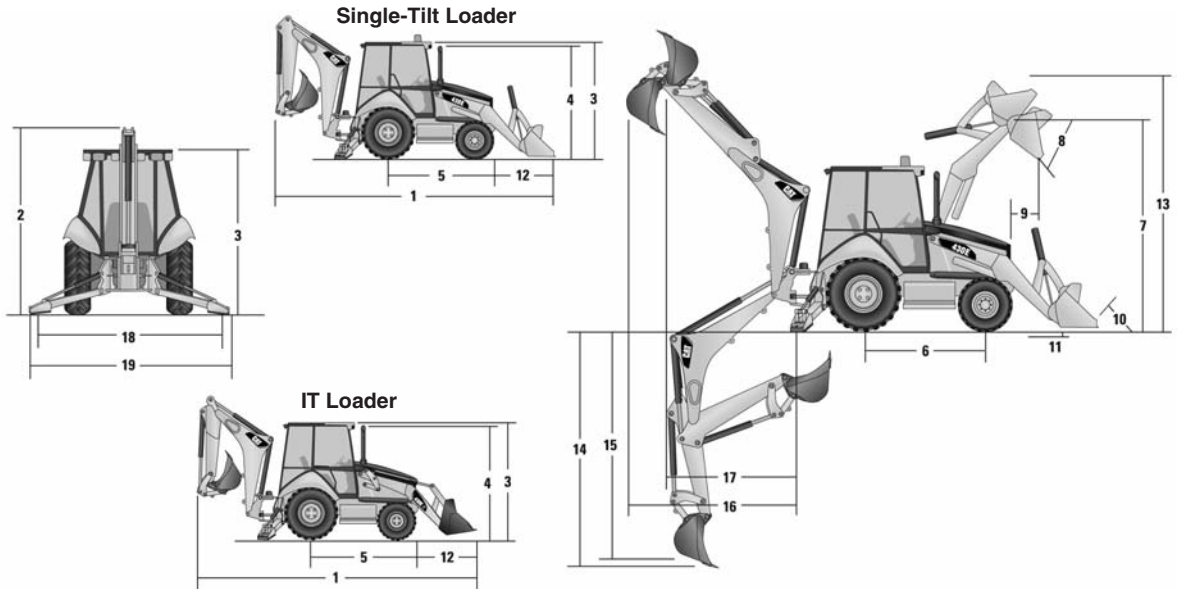

MACHINE DIMENSIONS	IT Loader with Quick Coupler					
	General Purpose 0.96 m <sup>3</sup> (1.25 yd <sup>3</sup> )		General Purpose 1.0 m <sup>3</sup> (1.31 yd <sup>3</sup> )		General Purpose 1.15 m <sup>3</sup> (1.50 yd <sup>3</sup> )	
1) Overall transport length	7464 mm	24'6"	7412 mm	24'4"	7455 mm	24'6"
Overall length	7419 mm	24'4"	7447 mm	24'5"	7471 mm	24'6"
2) Overall transport height	3577 mm	11'9"	3577 mm	11'9"	3577 mm	11'9"
Overall width	2322 mm	7'7"	2322 mm	7'7"	2322 mm	7'7"
3) Height to top of cab/canopy	2819 mm	9'3"	2819 mm	9'3"	2819 mm	9'3"
4) Height to top of exhaust stack	2754 mm	9'0"	2754 mm	9'0"	2754 mm	9'0"
Ground clearance (minimum)	320 mm	1'1"	320 mm	1'1"	320 mm	1'1"
5) Rear axle centerline to front grill	2705 mm	8'10"	2705 mm	8'10"	2705 mm	8'10"
Front wheel tread gauge	1880 mm	6'2"	1880 mm	6'2"	1880 mm	6'2"
Rear wheel tread gauge	1727 mm	5'8"	1727 mm	5'8"	1727 mm	5'8"
6) Wheelbase (2WD/AWD)	2200 mm	7'3"	2200 mm	7'3"	2200 mm	7'3"

MACHINE DIMENSIONS	IT Loader with Quick Coupler			
	Multi Purpose 0.96 m <sup>3</sup> (1.25 yd <sup>3</sup> )		Multi Purpose 1.03 m <sup>3</sup> (1.35 yd <sup>3</sup> )	
1) Overall transport length	7372 mm	24'2"	7372 mm	24'2"
Overall length	7349 mm	24'1"	7349 mm	24'1"
2) Overall transport height	3577 mm	11'9"	3577 mm	11'9"
Overall width	2322 mm	7'7"	2322 mm	7'7"
3) Height to top of cab/canopy	2819 mm	9'3"	2819 mm	9'3"
4) Height to top of exhaust stack	2754 mm	9'0"	2754 mm	9'0"
Ground clearance (minimum)	320 mm	1'1"	320 mm	1'1"
5) Rear axle centerline to front grill	2705 mm	8'10"	2705 mm	8'10"
Front wheel tread gauge	1880 mm	6'2"	1880 mm	6'2"
Rear wheel tread gauge	1727 mm	5'8"	1727 mm	5'8"
6) Wheelbase (2WD/AWD)	2200 mm	7'3"	2200 mm	7'3"

LOADER BUCKET DIMENSIONS AND PERFORMANCE	Single-Tilt Loader							
	General Purpose 0.96 m <sup>3</sup> (1.25 yd <sup>3</sup> )		General Purpose 1.0 m <sup>3</sup> (1.31 yd <sup>3</sup> )		General Purpose 1.07 m <sup>3</sup> (1.4 yd <sup>3</sup> )		General Purpose 1.15 m <sup>3</sup> (1.5 yd <sup>3</sup> )	
Capacity (SAE) rated	0.96 m <sup>3</sup>	<b>1.25 yd<sup>3</sup></b>	1.0 m <sup>3</sup>	<b>1.31 yd<sup>3</sup></b>	1.07 m <sup>3</sup>	<b>1.40 yd<sup>3</sup></b>	1.15 m <sup>3</sup>	<b>1.5 yd<sup>3</sup></b>
Width	2262 mm	<b>7'5"</b>	2406 mm	<b>7'11"</b>	2262 mm	<b>7'5"</b>	2406 mm	<b>7'11"</b>
Lift capacity at maximum height	2811 kg	<b>6197 lb</b>	2937 kg	<b>6475 lb</b>	2868 kg	<b>6323 lb</b>	2733 kg	<b>6025 lb</b>
Breakout force	44.3 kN	<b>9973 lbf</b>	46.3 kN	<b>10,401 lbf</b>	45.1 kN	<b>10,130 lbf</b>	43.6 kN	<b>9814 lbf</b>
7) Maximum hinge pin height	3368 mm	<b>11'1"</b>	3368 mm	<b>11'1"</b>	3368 mm	<b>11'1"</b>	3368 mm	<b>11'1"</b>
8) Dump angle at full height	<b>44°</b>		<b>44°</b>		<b>44°</b>		<b>46°</b>	
Dump height at maximum angle	2553 mm	<b>8'7"</b>	2604 mm	<b>8'7"</b>	2550 mm	<b>8'4"</b>	2529 mm	<b>8'4"</b>
9) Dump reach at maximum angle	785 mm	<b>2'8"</b>	821 mm	<b>2'8"</b>	819 mm	<b>2'8"</b>	752 mm	<b>2'6"</b>
10) Maximum bucket rollback at ground level	<b>39°</b>		<b>39°</b>		<b>40°</b>		<b>40°</b>	
11) Digging depth	106 mm	<b>4"</b>	106 mm	<b>4"</b>	146 mm	<b>6"</b>	146 mm	<b>6"</b>
Maximum grading angle	<b>108°</b>		<b>108°</b>		<b>108°</b>		<b>111°</b>	
Width of dozer cutting edge	<b>N/A</b>		<b>N/A</b>		<b>N/A</b>		<b>N/A</b>	
12) Grill to bucket cutting edge, carry position	1508 mm	<b>4'11"</b>	1484 mm	<b>4'10"</b>	1551 mm	<b>5'1"</b>	1544 mm	<b>5'1"</b>
13) Maximum operating height	4177 mm	<b>13'8"</b>	4193 mm	<b>13'9"</b>	4237 mm	<b>13'11"</b>	4216 mm	<b>12'11"</b>
Jaw opening maximum	<b>N/A</b>		<b>N/A</b>		<b>N/A</b>		<b>N/A</b>	
Weight (does not include teeth or forks)	451 kg	<b>944 lb</b>	449 kg	<b>989 lb</b>	459 kg	<b>1012 lb</b>	493 kg	<b>1088 lb</b>

LOADER BUCKET DIMENSIONS AND PERFORMANCE	Single-Tilt Loader							
	Multi Purpose 0.96 m <sup>3</sup> (1.25 yd <sup>3</sup> )		Multi Purpose 1.03 m <sup>3</sup> (1.35 yd <sup>3</sup> )		Multi Purpose with Forks 1.0 m <sup>3</sup> (1.31 yd <sup>3</sup> )		Multi Purpose with Forks 1.07 m <sup>3</sup> (1.4 yd <sup>3</sup> )	
Capacity (SAE) rated	0.96 m <sup>3</sup>	<b>1.25 yd<sup>3</sup></b>	1.03 m <sup>3</sup>	<b>1.35 yd<sup>3</sup></b>	1.0 m <sup>3</sup>	<b>1.31 yd<sup>3</sup></b>	1.07 m <sup>3</sup>	<b>1.4 yd<sup>3</sup></b>
Width	2279 mm	<b>7'6"</b>	2425 mm	<b>7'11"</b>	2279 mm	<b>7'6"</b>	2425 mm	<b>7'11"</b>
Lift capacity at maximum height	2616 kg	<b>5768 lb</b>	2587 mm	<b>5704 lb</b>	2500 kg	<b>5512 lb</b>	2471 kg	<b>5448 lb</b>
Breakout force	46.9 kN	<b>10,547 lbf</b>	46.7 kN	<b>10,514 lbf</b>	46 kN	<b>10,341 lbf</b>	45.8 kN	<b>10,308 lbf</b>
7) Maximum hinge pin height	3368 mm	<b>11'1"</b>	3368 mm	<b>11'1"</b>	3368 mm	<b>11'1"</b>	3368 mm	<b>11'1"</b>
8) Dump angle at full height	<b>46°</b>		<b>46°</b>		<b>46°</b>		<b>46°</b>	
Dump height at maximum angle	2605 mm	<b>8'7"</b>	2605 mm	<b>8'7"</b>	2605 mm	<b>8'7"</b>	2605 mm	<b>8'7"</b>
9) Dump reach at maximum angle	695 mm	<b>2'3"</b>	695 mm	<b>2'3"</b>	695 mm	<b>2'3"</b>	695 mm	<b>2'3"</b>
10) Maximum bucket rollback at ground level	<b>40°</b>		<b>40°</b>		<b>40°</b>		<b>40°</b>	
11) Digging depth	133 mm	<b>5"</b>	133 mm	<b>5"</b>	133 mm	<b>5"</b>	133 mm	<b>5"</b>
Maximum grading angle	<b>113°</b>		<b>113°</b>		<b>113°</b>		<b>113°</b>	
Width of dozer cutting edge	2262 mm	<b>7'5"</b>	2406 mm	<b>7'11"</b>	2262 mm	<b>7'5"</b>	2406 mm	<b>7'11"</b>
12) Grill to bucket cutting edge, carry position	1473 mm	<b>4'10"</b>	1473 mm	<b>4'10"</b>	1473 mm	<b>4'10"</b>	1473 mm	<b>4'10"</b>
13) Maximum operating height	4224 mm	<b>13'10"</b>	4224 mm	<b>13'10"</b>	4698 mm	<b>15'5"</b>	4698 mm	<b>15'5"</b>
Jaw opening maximum	790 mm	<b>2'7"</b>	790 mm	<b>2'7"</b>	790 mm	<b>2'7"</b>	790 mm	<b>2'7"</b>
Weight (does not include teeth or forks)	745 kg	<b>1642 lb</b>	774 kg	<b>1705 lb</b>	915 kg	<b>2016 lb</b>	936 kg	<b>2064 lb</b>

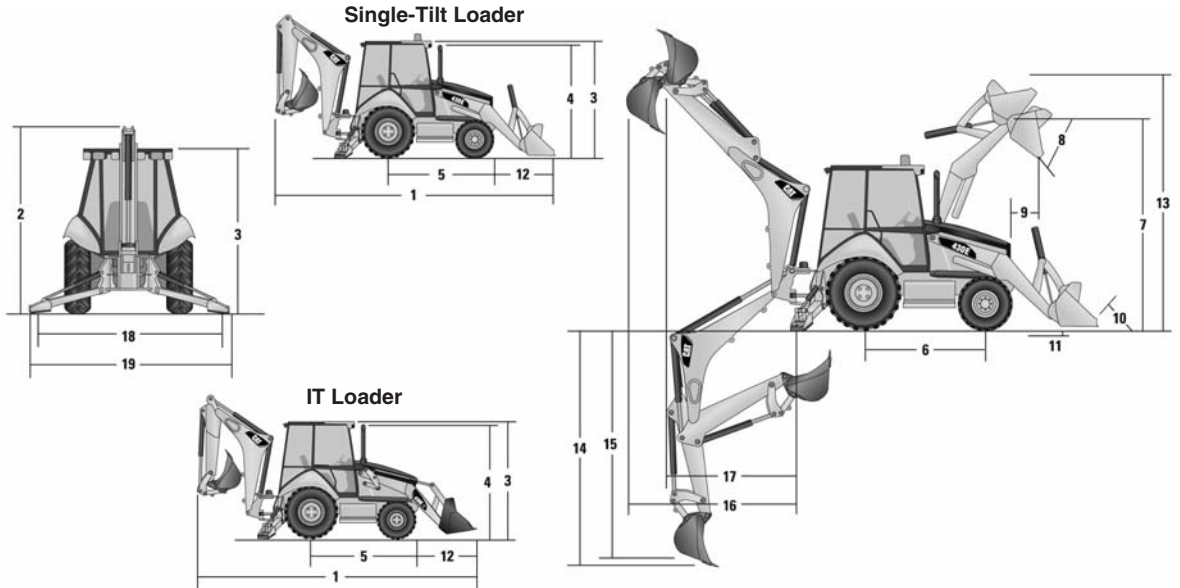

LOADER BUCKET DIMENSIONS AND PERFORMANCE	IT Loader with Quick Coupler					
	General Purpose 0.96 m <sup>3</sup> (1.25 yd <sup>3</sup> )		General Purpose 1.0 m <sup>3</sup> (1.31 yd <sup>3</sup> )		General Purpose 1.15 m <sup>3</sup> (1.5 yd <sup>3</sup> )	
Capacity (SAE) rated	0.96 m <sup>3</sup>	<b>1.25 yd<sup>3</sup></b>	1.0 m <sup>3</sup>	<b>1.31 yd<sup>3</sup></b>	1.15 m <sup>3</sup>	<b>1.5 yd<sup>3</sup></b>
Width	2262 mm	<b>7'5"</b>	2406 mm	<b>7'11"</b>	2406 mm	<b>7'11"</b>
Lift capacity at maximum height	3164 kg	<b>6975 lb</b>	3162 kg	<b>6971 kg</b>	3023 kg	<b>6664 kg</b>
Breakout force	47.1 kN	<b>10,593 lbf</b>	47.5 kN	<b>10,672 lbf</b>	45.5 kN	<b>10,235 lbf</b>
7) Maximum hinge pin height	3329 mm	<b>10'11"</b>	3329 mm	<b>10'11"</b>	3316 mm	<b>10'11"</b>
8) Dump angle at full height		<b>45°</b>		<b>45°</b>		<b>45°</b>
Dump height at maximum angle	2507 mm	<b>8'2"</b>	2539 mm	<b>8'4"</b>	2493 mm	<b>8'2"</b>
9) Dump reach at maximum angle	831 mm	<b>2'9"</b>	799 mm	<b>2'7"</b>	801 mm	<b>2'8"</b>
10) Maximum bucket rollback at ground level		<b>40°</b>		<b>40°</b>		<b>40°</b>
11) Digging depth	147 mm	<b>6"</b>	147 mm	<b>6"</b>	153 mm	<b>6"</b>
Maximum grading angle		<b>108°</b>		<b>110°</b>		<b>108°</b>
Width of dozer cutting edge		<b>N/A</b>		<b>N/A</b>		<b>N/A</b>
12) Grill to bucket cutting edge, carry position	1607 mm	<b>5'3"</b>	1575 mm	<b>5'2"</b>	1593 mm	<b>5'3"</b>
13) Maximum operating height	4260 mm	<b>14'0"</b>	4256 mm	<b>14'0"</b>	4303 mm	<b>14'1"</b>
Jaw opening maximum		<b>N/A</b>		<b>N/A</b>		<b>N/A</b>
Weight (does not include teeth or forks)	434 kg	<b>957 lb</b>	444 kg	<b>978 lb</b>	481 kg	<b>1060 lb</b>

LOADER BUCKET DIMENSIONS AND PERFORMANCE	IT Loader with Quick Coupler			
	Multi Purpose 0.96 m <sup>3</sup> (1.25 yd <sup>3</sup> )		Multi Purpose 1.03 m <sup>3</sup> (1.35 yd <sup>3</sup> )	
	Capacity (SAE) rated	0.96 m <sup>3</sup>	<b>1.25 yd<sup>3</sup></b>	1.03 m <sup>3</sup>
Width	2279 mm	<b>7'6"</b>	2425 mm	<b>7'11"</b>
Lift capacity at maximum height	2800 kg	<b>6174 lb</b>	2771 kg	<b>6110 lb</b>
Breakout force	44.5 kN	<b>10,020 lbf</b>	44.4 kN	<b>9983 lbf</b>
7) Maximum hinge pin height	3316 mm	<b>10'11"</b>	4306 mm	<b>14'2"</b>
8) Dump angle at full height		<b>45°</b>		<b>45°</b>
Dump height at maximum angle	2559 mm	<b>8'5"</b>	2559 mm	<b>8'5"</b>
9) Dump reach at maximum angle	748 mm	<b>2'5"</b>	748 mm	<b>2'5"</b>
10) Maximum bucket rollback at ground level		<b>40°</b>		<b>40°</b>
11) Digging depth	144 mm	<b>6"</b>	144 mm	<b>6"</b>
Maximum grading angle		<b>111°</b>		<b>111°</b>
Width of dozer cutting edge	2622 mm	<b>7'5"</b>	2406 mm	<b>7'11"</b>
12) Grill to bucket cutting edge, carry position	1526 mm	<b>5'0"</b>	1526 mm	<b>5'0"</b>
13) Maximum operating height	4306 mm	<b>14'2"</b>	4306 mm	<b>14'2"</b>
Jaw opening maximum	790 mm	<b>2'7"</b>	790 mm	<b>2'7"</b>
Weight (does not include teeth or forks)	724 kg	<b>1596 lb</b>	753 kg	<b>1660 lb</b>

BACKHOE DIMENSIONS AND PERFORMANCE	Standard Stick		Extendible Stick Retracted		Extendible Stick Extended	
	14) Digging depth, SAE (maximum)	4698 mm	<b>15'5"</b>	4809 mm	<b>15'9"</b>	5951 mm
15) Digging depth, 610 mm (2'0") flat bottom	4672 mm	<b>15'4"</b>	4783 mm	<b>15'8"</b>	5925 mm	<b>19'5"</b>
Reach from rear axle centerline at ground line	7152 mm	<b>23'6"</b>	7257 mm	<b>23'10"</b>	8350 mm	<b>27'5"</b>
16) Reach from swing pivot at ground line	6049 mm	<b>19'10"</b>	6154 mm	<b>20'2"</b>	7247 mm	<b>23'9"</b>
Maximum operating height	6009 mm	<b>19'9"</b>	6096 mm	<b>20'0"</b>	6990 mm	<b>22'11"</b>
Loading height	3956 mm	<b>13'0"</b>	3912 mm	<b>12'10"</b>	4520 mm	<b>14'10"</b>
17) Loading reach	1774 mm	<b>5'10"</b>	1948 mm	<b>6'5"</b>	2916 mm	<b>9'7"</b>
Swing arc		<b>180°</b>		<b>180°</b>		<b>180°</b>
Bucket rotation		<b>205°</b>		<b>205°</b>		<b>205°</b>
18) Stabilizer spread, operating position (center of pad)	3310 mm	<b>10'10"</b>	3310 mm	<b>10'10"</b>	3310 mm	<b>10'10"</b>
19) Stabilizer spread, operating position (outside edge of pad)	3770 mm	<b>12'4"</b>	3770 mm	<b>12'4"</b>	3770 mm	<b>12'4"</b>
Stabilizer spread, transport position	2322 mm	<b>7'7"</b>	2322 mm	<b>7'7"</b>	2322 mm	<b>7'7"</b>
Bucket dig force	70.7 kN	<b>15,892 lbf</b>	69.7 kN	<b>15,680 lbf</b>	69.7 kN	<b>15,680 lbf</b>
Stick dig force	44.2 kN	<b>9940 lbf</b>	43.3 kN	<b>9730 lbf</b>	32.0 kN	<b>7197 lbf</b>

DIMENSIONS WITH FORKS/ MATERIAL-HANDLING ARM	Cat 430E IT Operating Specifications with Forks					
Fork Tine Length	1070 mm (3'6")		1220 mm (4'0")		1370 mm (4'6")	
Operating load (SAE J1197)	2403 kg*	<b>5298 lb*</b>	2258 kg*	<b>4978 lb*</b>	2089 kg*	<b>4604 lb*</b>
SAE load center	535 mm	<b>1'9"</b>	610 mm	<b>2'0"</b>	685 mm	<b>2'3"</b>
Operating load (CEN 474-4)	2428 kg	<b>5353 lb</b>	2406 kg	<b>5304 lb</b>	2382 kg	<b>5252 lb</b>
CEN load center	500 mm	<b>1'8"</b>	500 mm	<b>1'8"</b>	500 mm	<b>1'8"</b>
Overall length (A) (forks on ground)	7857 mm	<b>25'9"</b>	8007 mm	<b>26'3"</b>	8157 mm	<b>26'9"</b>

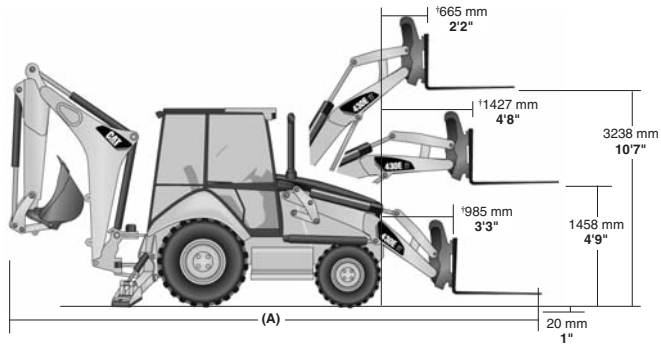

\*Tip limited.  
 †Measured from nose of machine.

DIMENSIONS WITH FORKS/ MATERIAL-HANDLING ARM	Cat 430E IT Operating Specifications with Material-Handling Arm					
Material-Handling Arm Position	Retracted		Mid-Position		Extended	
Operating load (SAE J1197 and CEN 474-4)	906 kg**	<b>1998 lb**</b>	572 kg**	<b>1261 lb**</b>	418 kg**	<b>921 lb**</b>
Overall length, maximum	8948 mm	<b>29'4"</b>	9948 mm	<b>32'8"</b>	10 947 mm	<b>35'11"</b>

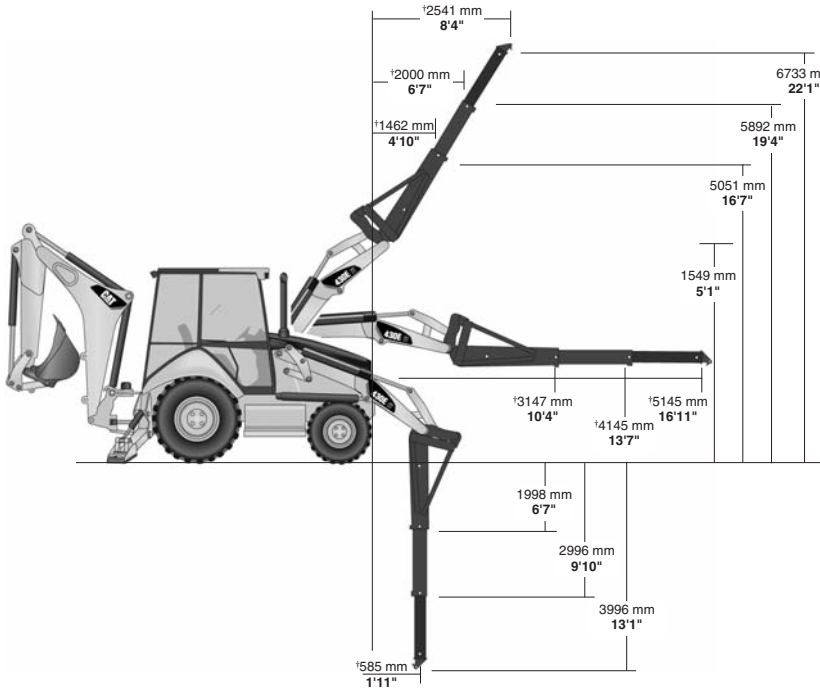

\*\*Hydraulically limited.  
 Dimensions and performance specifications shown are for 4WD machines equipped with 12.5/80-18 SGL front tires, 19.5L-24 IT525 rear tires, ROPS canopy, standard stick with 610 mm (24 in) standard duty bucket, and 1.00 m<sup>3</sup> (1.31 yd<sup>3</sup>) loader bucket and standard equipment unless otherwise specified.  
 †Measured from nose of machine.

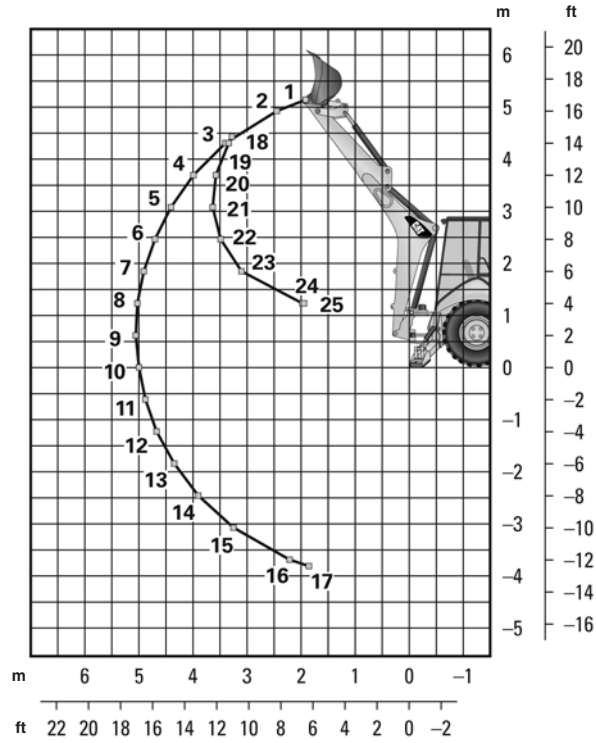

**Standard Stick**

Boom Lifting

1	1469 kg	3232 lb
2	1740 kg	3828 lb
3	1906 kg	4193 lb
4	1901 kg	4183 lb
5	1857 kg	4086 lb
6	1801 kg	3962 lb
7	1715 kg	3773 lb
8	1648 kg	3626 lb
9	1619 kg	3562 lb
10	1577 kg	3469 lb
11	1530 kg	3365 lb
12	1488 kg	3273 lb
13	1452 kg	3195 lb
14	1427 kg	3139 lb
15	1423 kg	3130 lb
16	1507 kg	3315 lb
17	1587 kg	3492 lb

Stick Lifting

18	2436 kg	5359 lb
19	2615 kg	5754 lb
20	2684 kg	5906 lb
21	2629 kg	5783 lb
22	2755 kg	6061 lb
23	3139 kg	6907 lb
24	5259 kg	11,571 lb
25	5368 kg	11,809 lb

Lift Capacities are over-end values. Machine equipped with AWD, OROPS, 1.0 m<sup>3</sup> (1.31 yd<sup>3</sup>) general purpose bucket, and 113 kg (250 lb) counterweight. Extendible stick includes 485 kg (1070 lb) counterweight.

# Backhoe Loaders

## Lift Capacities ● 430E/430E IT

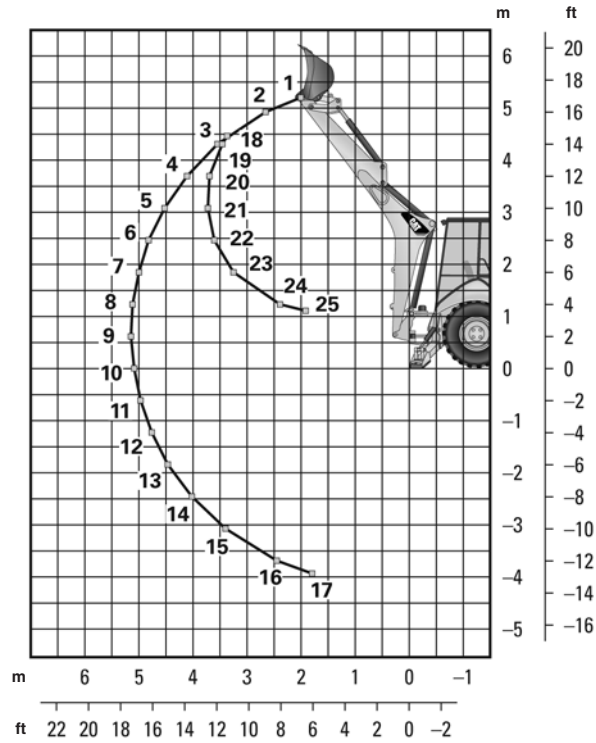

### Extendible Stick Retracted

#### Boom Lifting

1	1214 kg	2670 lb
2	1505 kg	3311 lb
3	1639 kg	3606 lb
4	1635 kg	3598 lb
5	1595 kg	3510 lb
6	1543 kg	3395 lb
7	1488 kg	3273 lb
8	1433 kg	3152 lb
9	1380 kg	3036 lb
10	1330 kg	2927 lb
11	1284 kg	2826 lb
12	1243 kg	2735 lb
13	1208 kg	2657 lb
14	1181 kg	2598 lb
15	1172 kg	2578 lb
16	1224 kg	2693 lb
17	1345 kg	2959 lb

#### Stick Lifting

18	2142 kg	4711 lb
19	2348 kg	5165 lb
20	2400 kg	5280 lb
21	2350 kg	5170 lb
22	2457 kg	5406 lb
23	2817 kg	6197 lb
24	4270 kg	9394 lb
25	5815 kg	12,793 lb

Lift Capacities are over-end values. Machine equipped with AWD, OROPS, 1.0 m<sup>3</sup> (1.31 yd<sup>3</sup>) general purpose bucket, and 113 kg (250 lb) counterweight. Extendible stick includes 485 kg (1070 lb) counterweight.

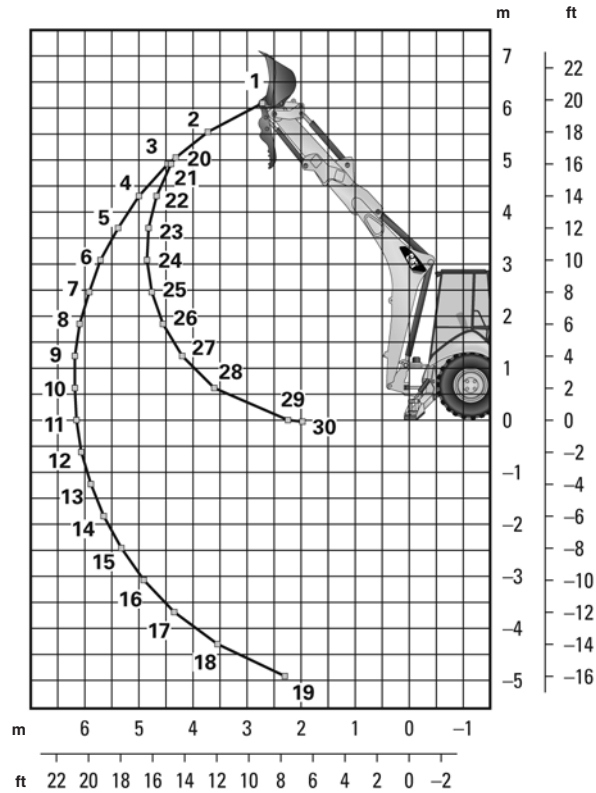

**Extendible Stick Extended**

Boom Lifting

1	657 kg	1446 lb
2	993 kg	2185 lb
3	1106 kg	2433 lb
4	1143 kg	2514 lb
5	1148 kg	2525 lb
6	1138 kg	2503 lb
7	1120 kg	2464 lb
8	1098 kg	2416 lb
9	1075 kg	2364 lb
10	1051 kg	2312 lb
11	1028 kg	2261 lb
12	1006 kg	2213 lb
13	987 kg	2171 lb
14	971 kg	2135 lb
15	959 kg	2110 lb
16	956 kg	2102 lb
17	966 kg	2125 lb
18	1011 kg	2223 lb
19	1224 kg	2694 lb

Stick Lifting

20	1187 kg	2612 lb
21	1266 kg	2786 lb
22	1553 kg	3416 lb
23	1634 kg	3595 lb
24	1615 kg	3553 lb
25	1650 kg	3630 lb
26	1752 kg	3854 lb
27	1960 kg	4312 lb
28	2419 kg	5322 lb
29	4631 kg	10,187 lb
30	5624 kg	12,373 lb

Lift Capacities are over-end values. Machine equipped with AWD, OROPS, 1.0 m<sup>3</sup> (1.31 yd<sup>3</sup>) general purpose bucket, and 113 kg (250 lb) counterweight. Extendible stick includes 485 kg (1070 lb) counterweight.



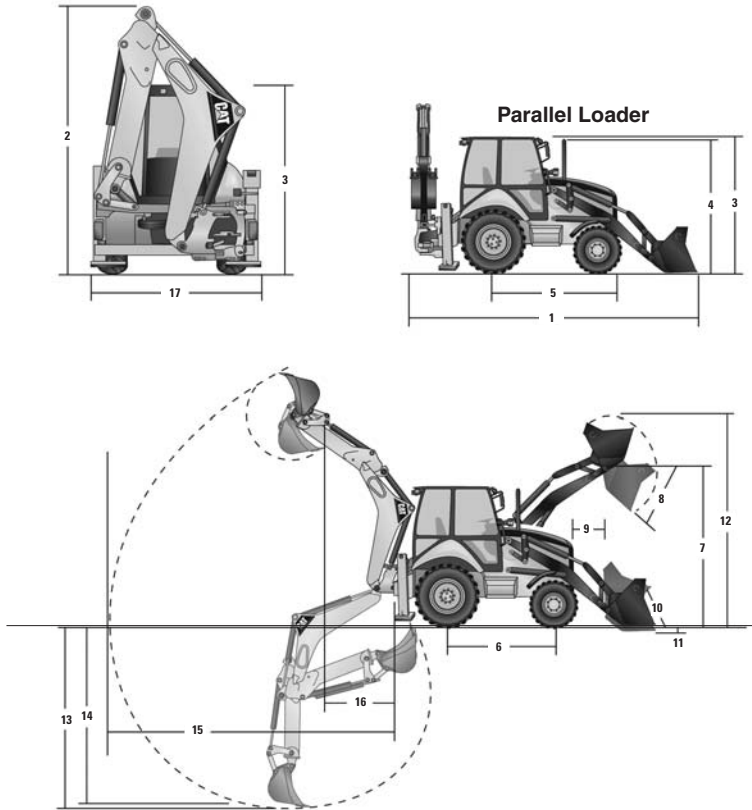

MACHINE DIMENSIONS	General Purpose		Multi Purpose		Multi Purpose with Forks		
	mm	ft"	mm	ft"	mm	ft"	
1) Overall length (loader on ground) S-Stick	5810 mm	19'1"	5754 mm	18'11"	5754 mm	18'11"	
	Overall length (loader on ground) E-Stick	5810 mm	19'1"	5754 mm	18'11"	5754 mm	18'11"
Overall transport length S-Stick	5836 mm	19'2"	5811 mm	19'1"	5811 mm	19'1"	
	Overall transport length E-Stick	5838 mm	19'2"	5813 mm	19'1"	5813 mm	19'1"
2) Overall transport height S-Stick	3736 mm	12'3"	3736 mm	12'3"	3736 mm	12'3"	
	Overall transport height E-Stick	3759 mm	12'4"	3759 mm	12'4"	3759 mm	12'4"
Overall width (Standard)	2368 mm	7'9"	2368 mm	7'9"	2368 mm	7'9"	
	Overall width (Narrow)	2242 mm	7'4"	2242 mm	7'4"	2242 mm	7'4"
3) Height to top of cab/canopy	2863 mm	9'5"	2863 mm	9'5"	2863 mm	9'5"	
4) Height to top of exhaust stack	2779 mm	9'1"	2779 mm	9'1"	2779 mm	9'1"	
	Height to loader hinge pin (transport)	403 mm	1'4"	429 mm	1'5"	429 mm	1'5"
Ground clearance (minimum)	358 mm	1'2"	358 mm	1'2"	358 mm	1'2"	
5) Rear axle centerline to front grill	2704 mm	8'10"	2704 mm	8'10"	2704 mm	8'10"	
	Front wheel tread gauge	1915 mm	6'3"	1915 mm	6'3"	1915 mm	6'3"
	Rear wheel tread gauge	1713 mm	5'7"	1713 mm	5'7"	1713 mm	5'7"
6) Wheelbase (AWD)	2200 mm	7'3"	2200 mm	7'3"	2200 mm	7'3"	

LOADER BUCKET DIMENSIONS AND PERFORMANCE	Standard Frame					
	General Purpose		Multi Purpose		Multi Purpose with Forks	
	Capacity (SAE) rated	1.0 m <sup>3</sup>	<b>1.30 yd<sup>3</sup></b>	1.03 m <sup>3</sup>	<b>1.34 yd<sup>3</sup></b>	1.03 m <sup>3</sup>
Width	2406 mm	<b>7'11"</b>	2406 mm	<b>7'11"</b>	2406 mm	<b>7'11"</b>
Lift capacity at maximum height	3322 kg	<b>7324 lb</b>	3069 kg	<b>6766 lb</b>	2899 kg	<b>6391 lb</b>
Breakout force	55 kN	<b>12,364 lbf</b>	61 kN	<b>13,713 lbf</b>	60 kN	<b>13,489 lbf</b>
Tipping load at bucket load point	6217 kg	<b>13,706 lb</b>	6252 kg	<b>13,783 lb</b>	6101 kg	<b>13,450 lb</b>
7) Maximum hinge pin height	3290 mm	<b>10'10"</b>	3290 mm	<b>10'10"</b>	3290 mm	<b>10'10"</b>
8) Dump angle at full height		<b>47°</b>		<b>47°</b>		<b>47°</b>
Dump height at maximum angle	2574 mm	<b>8'5"</b>	2610 mm	<b>8'7"</b>	2610 mm	<b>8'7"</b>
9) Dump reach at maximum angle	743 mm	<b>2'5"</b>	671 mm	<b>2'2"</b>	671 mm	<b>2'2"</b>
10) Maximum bucket rollback at ground level		<b>39°</b>		<b>40°</b>		<b>40°</b>
11) Digging depth	138 mm	<b>5"</b>	166 mm	<b>7"</b>	166 mm	<b>7"</b>
Maximum grading angle		<b>112°</b>		<b>115°</b>		<b>115°</b>
Width of dozer cutting edge		<b>N/A</b>	2406 mm	<b>7'11"</b>	2406 mm	<b>7'11"</b>
12) Maximum operating height	4107 mm	<b>13'6"</b>	4125 mm	<b>13'6"</b>	4125 mm	<b>13'6"</b>
Jaw opening maximum		<b>N/A</b>	790 mm	<b>2'7"</b>	790 mm	<b>2'7"</b>
Bucket jaw clamping force		<b>N/A</b>	56 kN	<b>12,589 lbf</b>	56 kN	<b>12,589 lbf</b>
Weight (does not include teeth or forks)	428 kg	<b>944 lb</b>	611 kg	<b>1347 lb</b>	844 kg	<b>1861 lb</b>

LOADER BUCKET DIMENSIONS AND PERFORMANCE	Narrow Frame					
	General Purpose		Multi Purpose		Multi Purpose with Forks	
	Capacity (SAE) rated	1.0 m <sup>3</sup>	<b>1.30 yd<sup>3</sup></b>	1.03 m <sup>3</sup>	<b>1.34 yd<sup>3</sup></b>	1.03 m <sup>3</sup>
Width	2406 mm	<b>7'11"</b>	2406 mm	<b>7'11"</b>	2406 mm	<b>7'11"</b>
Lift capacity at maximum height	3330 kg	<b>7341 lb</b>	3126 kg	<b>6892 lb</b>	2966 kg	<b>6539 lb</b>
Breakout force	52 kN	<b>12,364 lbf</b>	61 kN	<b>13,713 lbf</b>	61 kN	<b>13,713 lbf</b>
Tipping load at bucket load point	5871 kg	<b>12,943 lb</b>	6061 kg	<b>13,362 lb</b>	5937 kg	<b>13,089 lb</b>
7) Maximum hinge pin height	3291 mm	<b>10'10"</b>	3291 mm	<b>10'10"</b>	3291 mm	<b>10'10"</b>
8) Dump angle at full height		<b>47°</b>		<b>47°</b>		<b>47°</b>
Dump height at maximum angle	2542 mm	<b>8'4"</b>	2610 mm	<b>8'7"</b>	2610 mm	<b>8'7"</b>
9) Dump reach at maximum angle	775 mm	<b>2'7"</b>	671 mm	<b>2'2"</b>	671 mm	<b>2'2"</b>
10) Maximum bucket rollback at ground level		<b>39°</b>		<b>40°</b>		<b>40°</b>
11) Digging depth	138 mm	<b>5"</b>	165 mm	<b>6"</b>	165 mm	<b>6"</b>
Maximum grading angle		<b>111°</b>		<b>115°</b>		<b>115°</b>
Width of dozer cutting edge		<b>N/A</b>	2406 mm	<b>7'11"</b>	2406 mm	<b>7'11"</b>
12) Maximum operating height	4133 mm	<b>12'10"</b>	4126 mm	<b>13'6"</b>	4126 mm	<b>13'6"</b>
Jaw opening maximum		<b>N/A</b>	790 mm	<b>2'7"</b>	790 mm	<b>2'7"</b>
Bucket jaw clamping force		<b>N/A</b>	56 kN	<b>12,589 lbf</b>	56 kN	<b>12,589 lbf</b>
Weight (does not include teeth or forks)	428 kg	<b>944 lb</b>	611 kg	<b>1347 lb</b>	844 kg	<b>1861 lb</b>

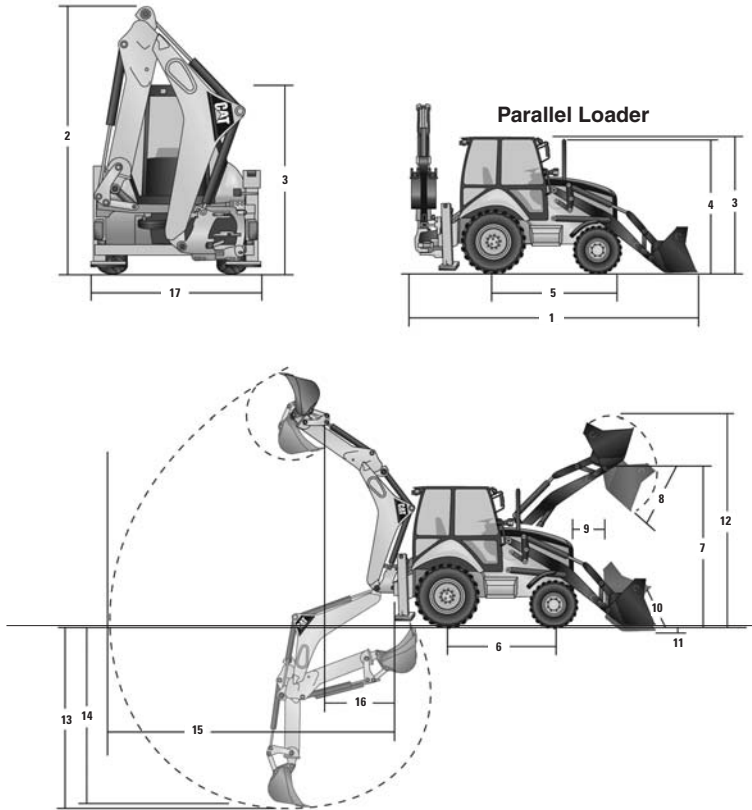

<b>BACKHOE DIMENSIONS AND PERFORMANCE</b>	<b>Standard Stick</b>		<b>Extendible Stick Retracted</b>		<b>Extendible Stick Extended</b>	
	13) Digging depth, manufacturers maximum	5022 mm	16'6"	4899 mm	16'1"	5840 mm
14) Digging depth, 610 mm (2'0") flat bottom	4979 mm	16'4"	4857 mm	15'11"	5815 mm	19'1"
15) Reach from swing pivot at ground line	5667 mm	18'7"	5657 mm	18'7"	6583 mm	21'7"
Loading height	3712 mm	12'2"	3914 mm	12'10"	4458 mm	14'8"
16) Loading reach	1827 mm	6'0"	1661 mm	5'5"	2560 mm	8'5"
Swing arc	180°		180°		180°	
Bucket rotation	205°		205°		205°	
17) Stabilizer width	2368 mm	7'9"	2368 mm	7'9"	2368 mm	7'9"
Bucket dig force	63 kN	14,163 lbf	63 kN	14,163 lbf	63 kN	14,163 lbf
Stick dig force	41 kN	9217 lbf	43 kN	9667 lbf	31 kN	6969 lbf
Total side shift travel (Standard frame)	1258 mm	4'2"	1258 mm	4'2"	1258 mm	4'2"
Total side shift travel (Narrow frame)	1096 mm	3'7"	1096 mm	3'7"	1096 mm	3'7"

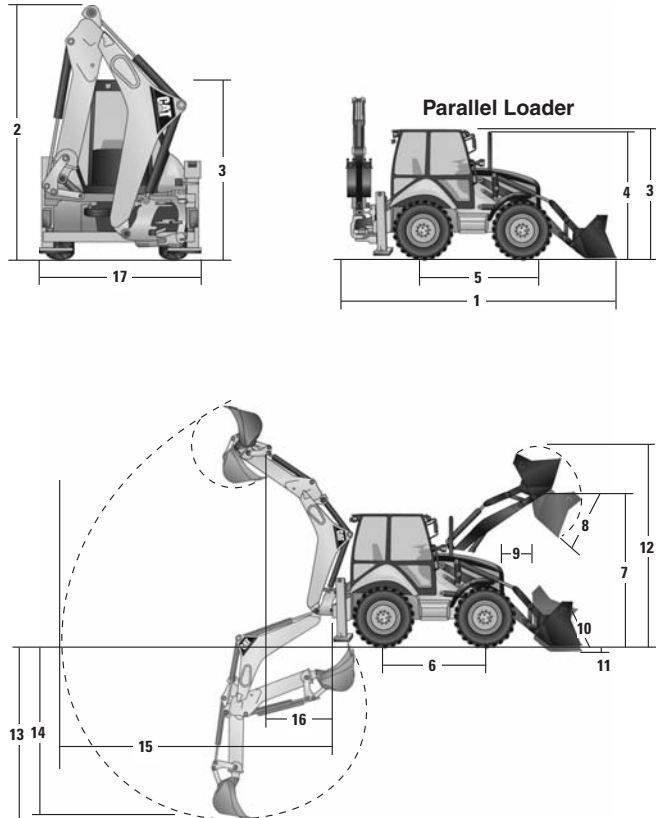

MACHINE DIMENSIONS	General Purpose		Multi Purpose		Multi Purpose with Forks	
	mm	ft"	mm	ft"	mm	ft"
1) Overall length (loader on ground) S-Stick	6120 mm	20'1"	6099 mm	20'0"	6099 mm	20'0"
	6120 mm	20'1"	6099 mm	20'0"	6099 mm	20'0"
Overall length (loader on ground) E-Stick	6120 mm	20'1"	6105 mm	20'0"	6105 mm	20'0"
	6120 mm	20'1"	6105 mm	20'0"	6105 mm	20'0"
2) Overall transport length S-Stick	6120 mm	20'1"	3623 mm	11'11"	3623 mm	11'11"
	6120 mm	20'1"	3623 mm	11'11"	3623 mm	11'11"
Overall transport length E-Stick	3647 mm	12'0"	3647 mm	12'0"	3647 mm	12'0"
	3647 mm	12'0"	3647 mm	12'0"	3647 mm	12'0"
3) Overall width	2368 mm	7'9"	2368 mm	7'9"	2368 mm	7'9"
	2368 mm	7'9"	2368 mm	7'9"	2368 mm	7'9"
4) Height to top of cab/canopy	2801 mm	9'5"	2801 mm	9'5"	2801 mm	9'5"
	2801 mm	9'5"	2801 mm	9'5"	2801 mm	9'5"
5) Height to top of exhaust stack	2733 mm	9'1"	2733 mm	9'1"	2733 mm	9'1"
	2733 mm	9'1"	2733 mm	9'1"	2733 mm	9'1"
Height to loader hinge pin (transport)	402 mm	1'4"	402 mm	1'4"	402 mm	1'4"
	402 mm	1'4"	402 mm	1'4"	402 mm	1'4"
6) Ground clearance (minimum)	325 mm	1'2"	325 mm	1'2"	325 mm	1'2"
	325 mm	1'2"	325 mm	1'2"	325 mm	1'2"
7) Rear axle centerline to front grill	2743 mm	9'0"	2743 mm	9'0"	2743 mm	9'0"
	2743 mm	9'0"	2743 mm	9'0"	2743 mm	9'0"
8) Front wheel tread gauge	1914 mm	6'3"	1914 mm	6'3"	1914 mm	6'3"
	1914 mm	6'3"	1914 mm	6'3"	1914 mm	6'3"
9) Rear wheel tread gauge	1914 mm	6'3"	1914 mm	6'3"	1914 mm	6'3"
	1914 mm	6'3"	1914 mm	6'3"	1914 mm	6'3"
10) Wheelbase (AWD)	2200 mm	7'3"	2200 mm	7'3"	2200 mm	7'3"
	2200 mm	7'3"	2200 mm	7'3"	2200 mm	7'3"

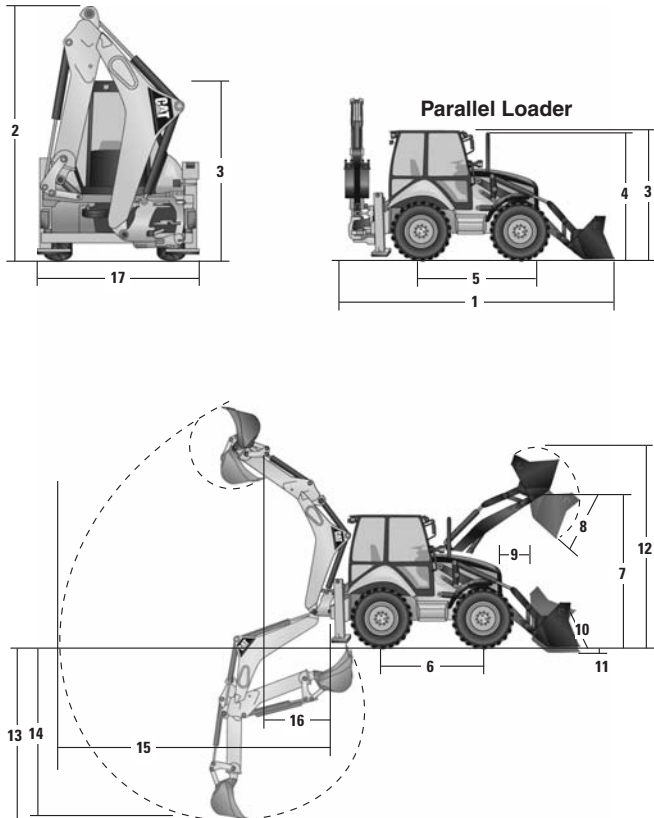

LOADER BUCKET DIMENSIONS AND PERFORMANCE	General Purpose		Multi Purpose		Multi Purpose with Forks	
Capacity (SAE) rated	1.15 m <sup>3</sup>	<b>1.5 yd<sup>3</sup></b>	1.15 m <sup>3</sup>	<b>1.5 yd<sup>3</sup></b>	1.15 m <sup>3</sup>	<b>1.5 yd<sup>3</sup></b>
Width	2434 mm	<b>8'0"</b>	2434 mm	<b>8'0"</b>	2434 mm	<b>8'0"</b>
Lift capacity at maximum height	3259 kg	<b>7185 lb</b>	3250 kg	<b>7165 lb</b>	3043 kg	<b>6709 lb</b>
Breakout force	56 kN	<b>12,589 lbf</b>	56 kN	<b>12,589 lbf</b>	55 kN	<b>12,364 lbf</b>
Tipping load at bucket load point	5974 kg	<b>13,170 lb</b>	5780 kg	<b>12,743 lb</b>	5596 kg	<b>12,337 lb</b>
7) Maximum hinge pin height	3442 mm	<b>11'4"</b>	3442 mm	<b>11'4"</b>	3442 mm	<b>11'4"</b>
8) Dump angle at full height		<b>45°</b>		<b>45°</b>		<b>45°</b>
Dump height at maximum angle	2666 mm	<b>8'9"</b>	2681 mm	<b>8'10"</b>	2681 mm	<b>8'10"</b>
9) Dump reach at maximum angle	903 mm	<b>3'0"</b>	889 mm	<b>2'11"</b>	889 mm	<b>2'11"</b>
10) Maximum bucket rollback at ground level		<b>41°</b>		<b>41°</b>		<b>41°</b>
11) Digging depth	229 mm	<b>9"</b>	229 mm	<b>9"</b>	229 mm	<b>9"</b>
Maximum grading angle		<b>107°</b>		<b>107°</b>		<b>107°</b>
Width of dozer cutting edge		<b>N/A</b>	2434 mm	<b>8'0"</b>	2434 mm	<b>8'0"</b>
12) Maximum operating height	4339 mm	<b>14'3"</b>	4409 mm	<b>14'6"</b>	4872 mm	<b>16'0"</b>
Jaw opening maximum		<b>N/A</b>	864 mm	<b>2'10"</b>	864 mm	<b>2'10"</b>
Bucket jaw clamping force		<b>N/A</b>	56 kN	<b>12,589 lbf</b>	56 kN	<b>12,589 lbf</b>
Weight (does not include teeth or forks)	438 kg	<b>966 lb</b>	744 kg	<b>1640 lb</b>	948 kg	<b>2090 lb</b>

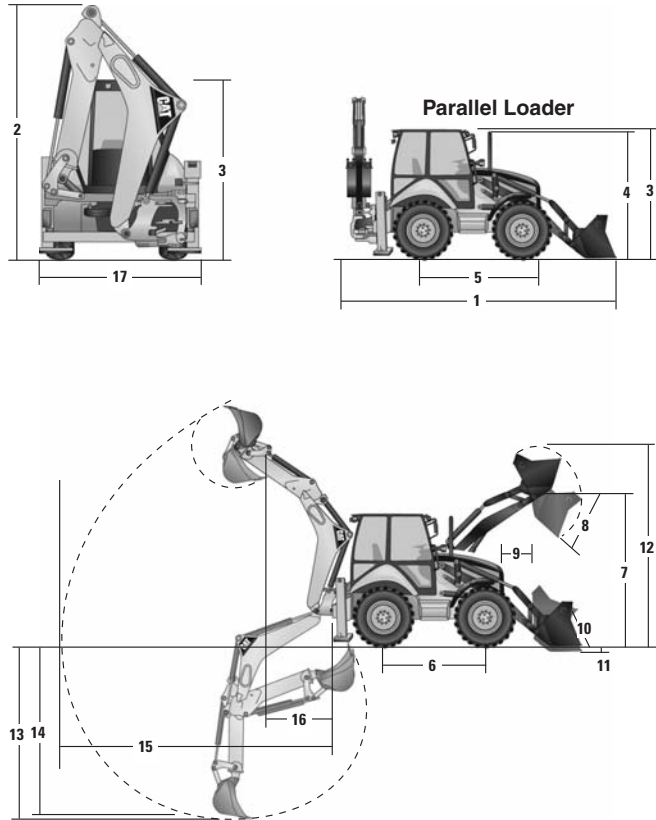

**BACKHOE DIMENSIONS AND PERFORMANCE**

	Standard Stick		Extendible Stick Retracted		Extendible Stick Extended	
13) Digging depth, manufacturers maximum	4919 mm	16'2"	4920 mm	16'2"	5863 mm	19'3"
14) Digging depth, 610 mm (2'0") flat bottom	4890 mm	16'1"	4893 mm	16'1"	5839 mm	19'2"
15) Reach from swing pivot at ground line	5660 mm	18'7"	5666 mm	18'7"	6590 mm	21'7"
Loading height	3759 mm	12'4"	3854 mm	12'8"	4398 mm	14'5"
16) Loading reach	1769 mm	5'10"	1688 mm	5'6"	2586 mm	8'6"
Swing arc	180°		180°		180°	
Bucket rotation	205°		205°		205°	
17) Stabilizer width	2368 mm	7'9"	2368 mm	7'9"	2368 mm	7'9"
Bucket dig force	63 kN	14,163 lbf	63 kN	14,163 lbf	63 kN	14,163 lbf
Stick dig force	35 kN	7868 lbf	36 kN	8093 lbf	26 kN	5845 lbf
Total side shift travel	1258 mm	4'2"	1258 mm	4'2"	1258 mm	4'2"

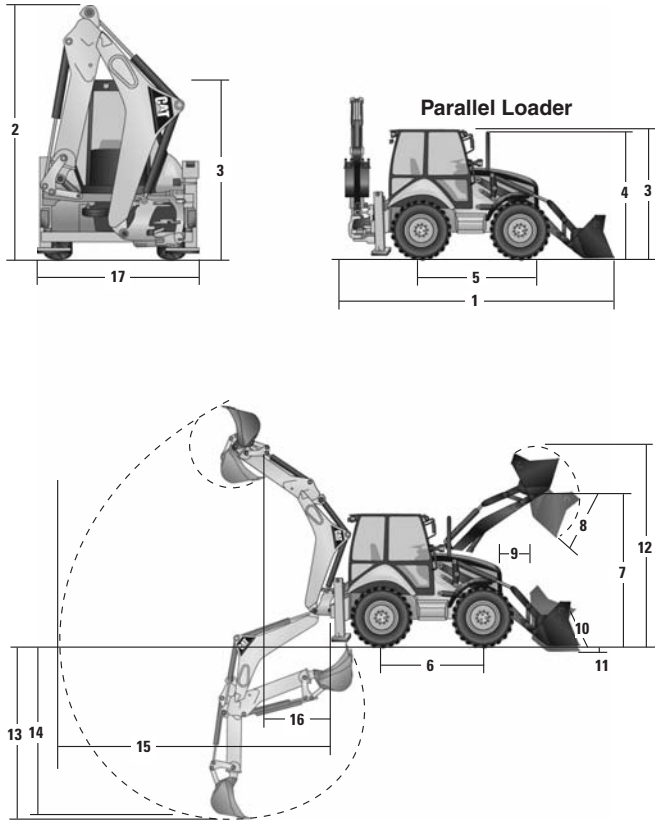

MACHINE DIMENSIONS	General Purpose		Multi Purpose		Multi Purpose with Forks	
	mm	ft"	mm	ft"	mm	ft"
1) Overall length (loader on ground) S-Stick	6120 mm	20'1"	6099 mm	20'0"	6099 mm	20'0"
Overall length (loader on ground) E-Stick	6120 mm	20'1"	6099 mm	20'0"	6099 mm	20'0"
Overall transport length S-Stick	6120 mm	20'1"	6105 mm	20'0"	6105 mm	20'0"
Overall transport length E-Stick	6120 mm	20'1"	6105 mm	20'0"	6105 mm	20'0"
2) Overall transport height S-Stick	3623 mm	11'11"	3623 mm	11'11"	3623 mm	11'11"
Overall transport height E-Stick	3647 mm	12'0"	3647 mm	12'0"	3647 mm	12'0"
Overall width	2368 mm	7'9"	2368 mm	7'9"	2368 mm	7'9"
3) Height to top of cab/canopy	2801 mm	9'5"	2801 mm	9'5"	2801 mm	9'5"
4) Height to top of exhaust stack	2733 mm	9'1"	2733 mm	9'1"	2733 mm	9'1"
Height to loader hinge pin (transport)	402 mm	1'4"	402 mm	1'4"	402 mm	1'4"
Ground clearance (minimum)	325 mm	1'2"	325 mm	1'2"	325 mm	1'2"
5) Rear axle centerline to front grill	2743 mm	9'0"	2743 mm	9'0"	2743 mm	9'0"
Front wheel tread gauge	1914 mm	6'3"	1914 mm	6'3"	1914 mm	6'3"
Rear wheel tread gauge	1914 mm	6'3"	1914 mm	6'3"	1914 mm	6'3"
6) Wheelbase (AWD)	2200 mm	7'3"	2200 mm	7'3"	2200 mm	7'3"

LOADER BUCKET DIMENSIONS AND PERFORMANCE	General Purpose		Multi Purpose		Multi Purpose with Forks	
	Capacity (SAE) rated	1.15 m <sup>3</sup>	<b>1.5 yd<sup>3</sup></b>	1.15 m <sup>3</sup>	<b>1.5 yd<sup>3</sup></b>	1.15 m <sup>3</sup>
Width	2434 mm	<b>8'0"</b>	2434 mm	<b>8'0"</b>	2434 mm	<b>8'0"</b>
Lift capacity at maximum height	3259 kg	<b>7185 lb</b>	3250 kg	<b>7165 lb</b>	3043 kg	<b>6709 lb</b>
Breakout force	56 kN	<b>12,589 lbf</b>	56 kN	<b>12,589 lbf</b>	55 kN	<b>12,364 lbf</b>
Tipping load at bucket load point	6100 kg	<b>13,448 lb</b>	5907 kg	<b>13,023 lb</b>	5723 kg	<b>12,617 lb</b>
7) Maximum hinge pin height	3442 mm	<b>11'4"</b>	3442 mm	<b>11'4"</b>	3442 mm	<b>11'4"</b>
8) Dump angle at full height		<b>45°</b>		<b>45°</b>		<b>45°</b>
Dump height at maximum angle	2666 mm	<b>8'9"</b>	2681 mm	<b>8'10"</b>	2681 mm	<b>8'10"</b>
9) Dump reach at maximum angle	903 mm	<b>3'0"</b>	889 mm	<b>2'11"</b>	889 mm	<b>2'11"</b>
10) Maximum bucket rollback at ground level		<b>41°</b>		<b>41°</b>		<b>41°</b>
11) Digging depth	229 mm	<b>9"</b>	229 mm	<b>9"</b>	229 mm	<b>9"</b>
Maximum grading angle		<b>107°</b>		<b>107°</b>		<b>107°</b>
Width of dozer cutting edge		<b>N/A</b>	2434 mm	<b>8'0"</b>	2434 mm	<b>8'0"</b>
12) Maximum operating height	4339 mm	<b>14'3"</b>	4409 mm	<b>14'6"</b>	4872 mm	<b>16'0"</b>
Jaw opening maximum		<b>N/A</b>	864 mm	<b>2'10"</b>	864 mm	<b>2'10"</b>
Bucket jaw clamping force		<b>N/A</b>	56 kN	<b>12,589 lbf</b>	56 kN	<b>12,589 lbf</b>
Weight (does not include teeth or forks)	438 kg	<b>966 lb</b>	744 kg	<b>1640 lb</b>	948 kg	<b>2090 lb</b>

BACKHOE DIMENSIONS AND PERFORMANCE	Standard Stick		Extendible Stick Retracted		Extendible Stick Extended	
	13) Digging depth, manufacturers maximum	4919 mm	<b>16'2"</b>	4920 mm	<b>16'2"</b>	5863 mm
14) Digging depth, 610 mm (2'0") flat bottom	4890 mm	<b>16'1"</b>	4893 mm	<b>16'1"</b>	5839 mm	<b>19'2"</b>
15) Reach from swing pivot at ground line	5660 mm	<b>18'7"</b>	5666 mm	<b>18'7"</b>	6590 mm	<b>21'7"</b>
Loading height	3759 mm	<b>12'4"</b>	3854 mm	<b>12'8"</b>	4398 mm	<b>14'5"</b>
16) Loading reach	1769 mm	<b>5'10"</b>	1688 mm	<b>5'6"</b>	2586 mm	<b>8'6"</b>
Swing arc		<b>180°</b>		<b>180°</b>		<b>180°</b>
Bucket rotation		<b>205°</b>		<b>205°</b>		<b>205°</b>
17) Stabilizer width	2368 mm	<b>7'9"</b>	2368 mm	<b>7'9"</b>	2368 mm	<b>7'9"</b>
Bucket dig force	63 kN	<b>14,163 lbf</b>	63 kN	<b>14,163 lbf</b>	63 kN	<b>14,163 lbf</b>
Stick dig force	42 kN	<b>9442 lbf</b>	42 kN	<b>9442 lbf</b>	31 kN	<b>6969 lbf</b>
Total side shift travel	1258 mm	<b>4'2"</b>	1258 mm	<b>4'2"</b>	1258 mm	<b>4'2"</b>



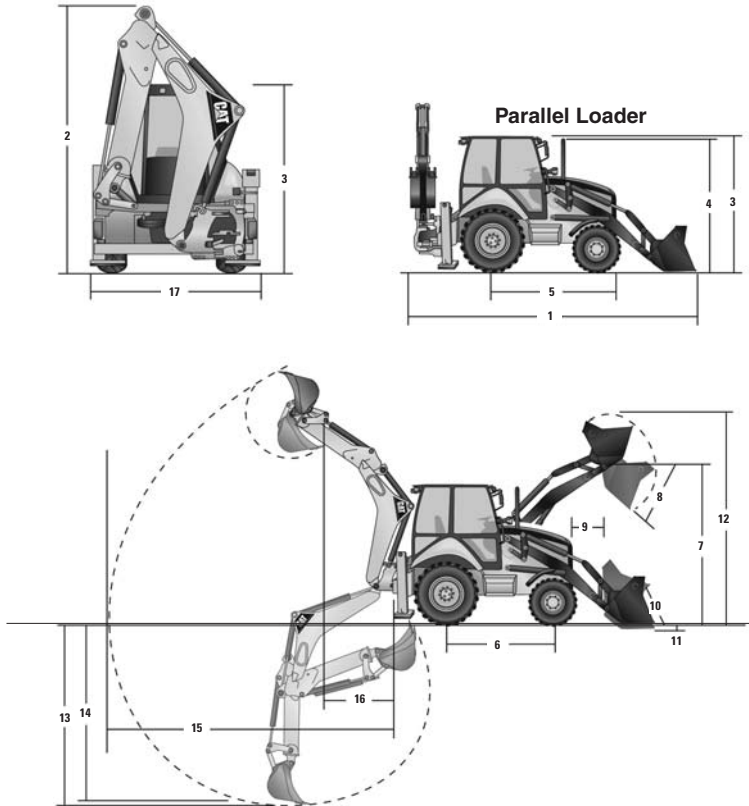

MACHINE DIMENSIONS	General Purpose		Multi Purpose		Multi Purpose with Forks	
	mm	ft"	mm	ft"	mm	ft"
1) Overall length (loader on ground) S-Stick	5809 mm	19'1"	5752 mm	18'11"	5752 mm	18'11"
Overall length (loader on ground) E-Stick	5809 mm	19'1"	5752 mm	18'11"	5752 mm	18'11"
Overall transport length S-Stick	5834 mm	19'2"	5810 mm	19'1"	5810 mm	19'1"
Overall transport length E-Stick	5839 mm	19'2"	5814 mm	19'1"	5814 mm	19'1"
2) Overall transport height S-Stick	3914 mm	12'10"	3914 mm	12'10"	3914 mm	12'10"
Overall transport height E-Stick	3939 mm	12'11"	3939 mm	12'11"	3939 mm	12'11"
Overall width	2368 mm	7'9"	2368 mm	7'9"	2368 mm	7'9"
3) Height to top of cab/canopy	2863 mm	9'5"	2863 mm	9'5"	2863 mm	9'5"
4) Height to top of exhaust stack	2779 mm	9'1"	2779 mm	9'1"	2779 mm	9'1"
Height to loader hinge pin (transport)	403 mm	1'4"	429 mm	1'5"	429 mm	1'5"
Ground clearance (minimum)	358 mm	1'2"	358 mm	1'2"	358 mm	1'2"
5) Rear axle centerline to front grill	2704 mm	8'10"	2704 mm	8'10"	2704 mm	8'10"
Front wheel tread gauge	1915 mm	6'3"	1915 mm	6'3"	1915 mm	6'3"
Rear wheel tread gauge	1713 mm	5'7"	1713 mm	5'7"	1713 mm	5'7"
6) Wheelbase (AWD)	2200 mm	7'3"	2200 mm	7'3"	2200 mm	7'3"

LOADER BUCKET DIMENSIONS AND PERFORMANCE	General Purpose		Multi Purpose		Multi Purpose with Forks	
	Capacity (SAE) rated	1.0 m <sup>3</sup>	<b>1.31 yd<sup>3</sup></b>	1.03 m <sup>3</sup>	<b>1.34 yd<sup>3</sup></b>	1.03 m <sup>3</sup>
Width	2406 mm	<b>7'11"</b>	2406 mm	<b>7'11"</b>	2406 mm	<b>7'11"</b>
Lift capacity at maximum height	3322 kg	<b>7324 lb</b>	3069 kg	<b>7165 lb</b>	2899 kg	<b>6391 lb</b>
Breakout force	55 kN	<b>12,364 lbf</b>	61 kN	<b>13,713 lbf</b>	60 kN	<b>13,489 lbf</b>
Tipping load at bucket load point	7696 kg	<b>16,967 lb</b>	7802 kg	<b>17,200 lb</b>	7652 kg	<b>16,870 lb</b>
7) Maximum hinge pin height	3340 mm	<b>10'11"</b>	3340 mm	<b>10'11"</b>	3340 mm	<b>10'11"</b>
8) Dump angle at full height		<b>45°</b>		<b>45°</b>		<b>45°</b>
Dump height at maximum angle	2634 mm	<b>8'8"</b>	2668 mm	<b>8'9"</b>	2668 mm	<b>8'9"</b>
9) Dump reach at maximum angle	795 mm	<b>2'7"</b>	724 mm	<b>2'5"</b>	724 mm	<b>2'5"</b>
10) Maximum bucket rollback at ground level		<b>39°</b>		<b>40°</b>		<b>40°</b>
11) Digging depth	91 mm	<b>9"</b>	118 mm	<b>5"</b>	118 mm	<b>5"</b>
Maximum grading angle		<b>112°</b>		<b>115°</b>		<b>115°</b>
Width of dozer cutting edge		<b>N/A</b>	2406 mm	<b>7'11"</b>	2406 mm	<b>7'11"</b>
12) Maximum operating height	4238 mm	<b>13'11"</b>	4264 mm	<b>14'0"</b>	4721 mm	<b>15'6"</b>
Jaw opening maximum		<b>N/A</b>	790 mm	<b>2'7"</b>	790 mm	<b>2'7"</b>
Bucket jaw clamping force		<b>N/A</b>	61 kN	<b>13,713 lbf</b>	61 kN	<b>13,713 lbf</b>
Weight (does not include teeth or forks)	428 kg	<b>944 lb</b>	611 kg	<b>1347 lb</b>	611 kg	<b>1347 lb</b>

BACKHOE DIMENSIONS AND PERFORMANCE	Extendible Stick Retracted		Extendible Stick Extended	
	13) Digging depth, manufacturers maximum	5302 mm	<b>17'5"</b>	6294 mm
14) Digging depth, 610 mm (2'0") flat bottom	5255 mm	<b>17'3"</b>	6258 mm	<b>20'6"</b>
15) Reach from swing pivot at ground line	6129 mm	<b>20'1"</b>	7080 mm	<b>23'3"</b>
Loading height	4247 mm	<b>13'11"</b>	4790 mm	<b>15'9"</b>
16) Loading reach	1723 mm	<b>5'8"</b>	2622 mm	<b>8'7"</b>
Swing arc		<b>180°</b>		<b>180°</b>
Bucket rotation		<b>205°</b>		<b>205°</b>
17) Stabilizer width	2368 mm	<b>7'9"</b>	2368 mm	<b>7'9"</b>
Bucket dig force	63 kN	<b>14,163 lbf</b>	63 kN	<b>14,163 lbf</b>
Stick dig force	46 kN	<b>10,341 lbf</b>	34 kN	<b>7644 lbf</b>
Total side shift travel	1258 mm	<b>4'2"</b>	1258 mm	<b>4'2"</b>

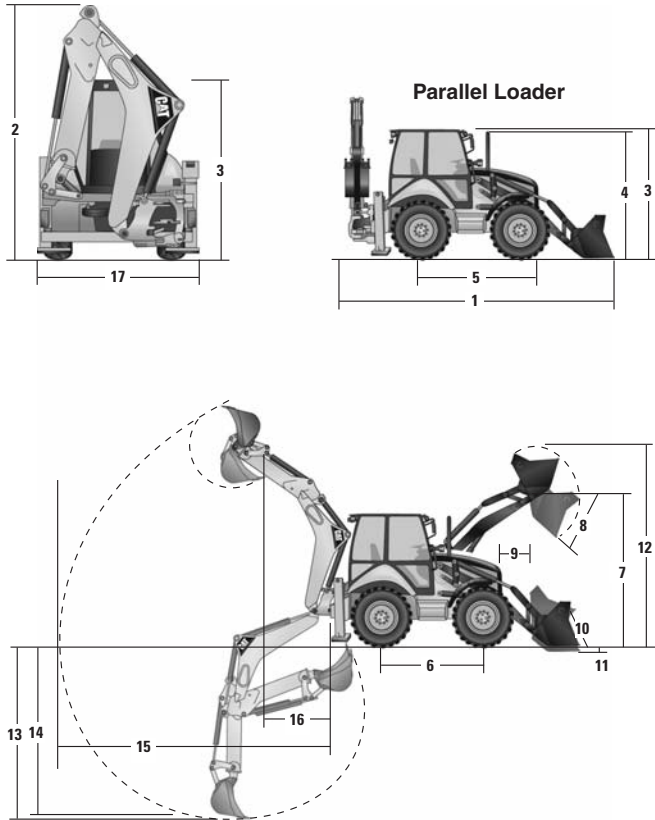

MACHINE DIMENSIONS	General Purpose		Multi Purpose		Multi Purpose with Forks	
	mm	ft"	mm	ft"	mm	ft"
1) Overall length (loader on ground) S-Stick	6085 mm	20'0"	6115 mm	20'1"	6115 mm	20'1"
Overall length (loader on ground) E-Stick	6085 mm	20'0"	6115 mm	20'1"	6115 mm	20'1"
Overall transport length S-Stick	6099 mm	20'0"	6119 mm	20'1"	6119 mm	20'1"
Overall transport length E-Stick	6099 mm	20'0"	6119 mm	20'1"	6119 mm	20'1"
2) Overall transport height S-Stick	3871 mm	12'8"	3871 mm	12'8"	3871 mm	12'8"
Overall transport height E-Stick	3896 mm	12'9"	3896 mm	12'9"	3896 mm	12'9"
Overall width	2368 mm	7'9"	2368 mm	7'9"	2368 mm	7'9"
3) Height to top of cab/canopy	2851 mm	9'4"	2851 mm	9'4"	2851 mm	9'4"
4) Height to top of exhaust stack	2783 mm	9'2"	2783 mm	9'2"	2783 mm	9'2"
Height to loader hinge pin (transport)	397 mm	1'4"	393 mm	1'3"	393 mm	1'3"
Ground clearance (minimum)	375 mm	1'3"	375 mm	1'3"	375 mm	1'3"
5) Rear axle centerline to front grill	2743 mm	9'0"	2743 mm	9'0"	2743 mm	9'0"
Front wheel tread gauge	1914 mm	6'3"	1914 mm	6'3"	1914 mm	6'3"
Rear wheel tread gauge	1914 mm	6'3"	1914 mm	6'3"	1914 mm	6'3"
6) Wheelbase (AWD)	2200 mm	7'3"	2200 mm	7'3"	2200 mm	7'3"

LOADER BUCKET DIMENSIONS AND PERFORMANCE	General Purpose		Multi Purpose		Multi Purpose with Forks	
	Capacity (SAE) rated	1.3 m <sup>3</sup>	<b>1.75 yd<sup>3</sup></b>	1.3 m <sup>3</sup>	<b>1.75 yd<sup>3</sup></b>	1.3 m <sup>3</sup>
Width	2434 mm	<b>8'0"</b>	2434 mm	<b>8'0"</b>	2434 mm	<b>8'0"</b>
Lift capacity at maximum height	3997 kg	<b>8812 lb</b>	3709 kg	<b>8177 lb</b>	3533 kg	<b>7789 lb</b>
Breakout force	64 kN	<b>14,388 lbf</b>	62 kN	<b>13,938 lbf</b>	60 kN	<b>13,489 lbf</b>
Tipping load at bucket load point	6587 kg	<b>14,522 lb</b>	6535 kg	<b>14,407 lb</b>	6350 kg	<b>13,999 lb</b>
7) Maximum hinge pin height	3496 mm	<b>11'6"</b>	3496 mm	<b>11'6"</b>	3496 mm	<b>11'6"</b>
8) Dump angle at full height		<b>45°</b>		<b>45°</b>		<b>45°</b>
Dump height at maximum angle	2720 mm	<b>8'11"</b>	2699 mm	<b>8'10"</b>	2699 mm	<b>8'10"</b>
9) Dump reach at maximum angle	848 mm	<b>2'9"</b>	869 mm	<b>2'10"</b>	869 mm	<b>2'10"</b>
10) Maximum bucket rollback at ground level		<b>40°</b>		<b>40°</b>		<b>40°</b>
11) Digging depth	175 mm	<b>9"</b>	175 mm	<b>9"</b>	175 mm	<b>9"</b>
Maximum grading angle		<b>108°</b>		<b>107°</b>		<b>107°</b>
Width of dozer cutting edge		<b>N/A</b>	2434 mm	<b>8'0"</b>	2434 mm	<b>8'0"</b>
12) Maximum operating height	4528 mm	<b>14'10"</b>	4520 mm	<b>14'10"</b>	4943 mm	<b>16'3"</b>
Jaw opening maximum		<b>N/A</b>	913 mm	<b>3'0"</b>	913 mm	<b>3'0"</b>
Bucket jaw clamping force		<b>N/A</b>	44 kN	<b>9892 lbf</b>	44 kN	<b>9892 lbf</b>
Weight (does not include teeth or forks)	462 kg	<b>1019 lb</b>	809 kg	<b>1784 lb</b>	809 kg	<b>1784 lb</b>

BACKHOE DIMENSIONS AND PERFORMANCE	Extendible Stick Retracted		Extendible Stick Extended	
	13) Digging depth, manufacturers maximum	5333 mm	<b>17'6"</b>	6313 mm
14) Digging depth, 610 mm (2'0") flat bottom	5296 mm	<b>17'5"</b>	6289 mm	<b>20'8"</b>
15) Reach from swing pivot at ground line	6140 mm	<b>20'2"</b>	7090 mm	<b>23'3"</b>
Loading height	4166 mm	<b>13'8"</b>	4709 mm	<b>15'5"</b>
16) Loading reach	1809 mm	<b>5'11"</b>	2708 mm	<b>8'11"</b>
Swing arc		<b>180°</b>		<b>180°</b>
Bucket rotation		<b>205°</b>		<b>205°</b>
17) Stabilizer width	2368 mm	<b>7'9"</b>	2368 mm	<b>7'9"</b>
Bucket dig force	63 kN	<b>14,163 lbf</b>	63 kN	<b>14,163 lbf</b>
Stick dig force	46 kN	<b>9667 lbf</b>	34 kN	<b>7644 lbf</b>
Total side shift travel	1258 mm	<b>4'2"</b>	1258 mm	<b>4'2"</b>

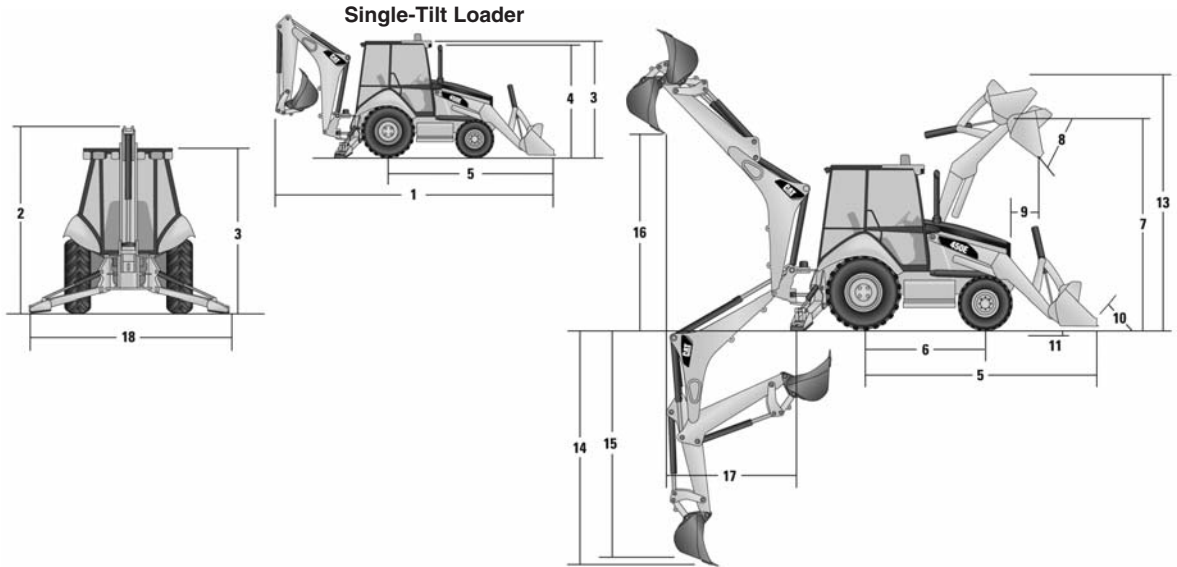

Dimensions and performance specifications shown are for machines equipped with 15-19.5 (12 PR) front tires, 21L-24 (18 PR) rear tires, ROPS canopy, standard stick with 610 mm (24 in) heavy-duty bucket, and 1.34 m<sup>3</sup> (1.75 yd<sup>3</sup>) loader bucket and standard equipment unless otherwise specified.

MACHINE DIMENSIONS	Single-Tilt Loader			
	General Purpose 1.3 m <sup>3</sup> (1.7 yd <sup>3</sup> )		Multi Purpose 1.25 m <sup>3</sup> (1.63 yd <sup>3</sup> )	
1) Overall length, loader on ground, standard stick	7913 mm	26'0"	7786 mm	25'7"
Overall length, loader on ground, extendible stick	7913 mm	26'0"	7786 mm	25'7"
Overall transport length, standard stick	7916 mm	26'0"	7826 mm	25'8"
Overall transport length, extendible stick	7916 mm	26'0"	7826 mm	25'8"
2) Overall transport height, standard stick	4143 mm	13'7"	4143 mm	13'7"
Overall transport height, extendible stick	4159 mm	13'8"	4159 mm	13'8"
Overall width	2436 mm	8'0"	2436 mm	8'0"
3) Height to top of cab/canopy	2874 mm	9'5"	2874 mm	9'5"
4) Height to top of exhaust stack	2845 mm	9'4"	2845 mm	9'4"
Rear axle centerline to front grill	2832 mm	9'4"	2832 mm	9'4"
Height to loader hinge pin (transport)	469 mm	1'6"	481 mm	1'7"
Ground clearance (minimum)	322 mm	1'1"	322 mm	1'1"
5) Rear axle to loader bucket on ground	4494 mm	14'9"	4367 mm	14'4"
Front wheel tread gauge	2016 mm	6'7"	2016 mm	6'7"
Rear wheel tread gauge	1814 mm	5'11"	1814 mm	5'11"
6) Wheelbase	2200 mm	7'3"	2200 mm	7'3"

LOADER BUCKET DIMENSIONS AND PERFORMANCE	Single-Tilt Loader					
	General Purpose 1.3 m <sup>3</sup> (1.75 yd <sup>3</sup> )		Multi Purpose 1.1 m <sup>3</sup> (1.5 yd <sup>3</sup> )		Multi Purpose with Forks 1.1 m <sup>3</sup> (1.5 yd <sup>3</sup> )	
Capacity (SAE) rated	1.3 m <sup>3</sup>	<b>1.75 yd<sup>3</sup></b>	1.1 m <sup>3</sup>	<b>1.5 yd<sup>3</sup></b>	1.1 m <sup>3</sup>	<b>1.5 yd<sup>3</sup></b>
Width	2434 mm	<b>8'0"</b>	2425 mm	<b>7'11"</b>	2425 mm	<b>7'11"</b>
Lift capacity at maximum height	3828 kg	<b>8439 lb</b>	3754 kg	<b>8276 lb</b>	3661 kg	<b>8071 lb</b>
Breakout force	51.2 kN	<b>11,512 lbf</b>	60.9 kN	<b>13,688 lbf</b>	60 kN	<b>13,488 lbf</b>
Tipping load at breakout point	8376 kg	<b>18,466 lb</b>	8160 kg	<b>17,990 lb</b>	8006 kg	<b>17,650 lb</b>
7) Maximum hinge pin height	3501 mm	<b>11'6"</b>	3501 mm	<b>11'6"</b>	3501 mm	<b>11'6"</b>
8) Dump angle at full height		<b>43°</b>		<b>43°</b>		<b>43°</b>
Dump height at maximum angle	2666 mm	<b>8'9"</b>	2759 mm	<b>9'1"</b>	2759 mm	<b>9'1"</b>
9) Dump reach at maximum angle	845 mm	<b>2'9"</b>	774 mm	<b>2'6"</b>	774 mm	<b>2'6"</b>
10) Maximum bucket rollback at ground level		<b>40°</b>		<b>40°</b>		<b>40°</b>
11) Digging depth	146 mm	<b>6"</b>	127 mm	<b>5"</b>	127 mm	<b>5"</b>
Maximum grading angle		<b>106°</b>		<b>109°</b>		<b>109°</b>
Width of dozer cutting edge		<b>N/A</b>	2406 mm	<b>7'11"</b>	2406 mm	<b>7'11"</b>
12) Grill to bucket cutting edge, carry position	1664 mm	<b>5'6"</b>	1571 mm	<b>5'2"</b>	1571 mm	<b>5'2"</b>
13) Maximum operating height	4528 mm	<b>14'10"</b>	4561 mm	<b>15'0"</b>	4881 mm	<b>16'0"</b>
Jaw opening maximum		<b>N/A</b>	864 mm	<b>2'10"</b>	864 mm	<b>2'10"</b>
Bucket jaw clamping force		<b>N/A</b>	39.8 kN	<b>8947 lbf</b>	39.8 kN	<b>8947 lbf</b>
Weight	1043 kg	<b>2300 lb</b>	957 kg	<b>2111 lb</b>	1148 kg	<b>2530 lb</b>

BACKHOE DIMENSIONS AND PERFORMANCE	Standard Stick		Extendible Stick Retracted		Extendible Stick Extended	
	14) Digging depth, SAE (maximum)	5260 mm	<b>17'3"</b>	5260 mm	<b>17'3"</b>	6501 mm
Digging depth, 2438 mm (8'0") flat bottom	4926 mm	<b>16'2"</b>	4926 mm	<b>16'2"</b>	6231 mm	<b>20'5"</b>
15) Digging depth, 610 mm (2'0") flat bottom	5224 mm	<b>17'2"</b>	5224 mm	<b>17'2"</b>	6466 mm	<b>21'3"</b>
Reach from rear axle centerline at ground line	7949 mm	<b>26'1"</b>	7949 mm	<b>26'1"</b>	9130 mm	<b>29'11"</b>
16) Reach from swing pivot at ground line	6697 mm	<b>22'0"</b>	6697 mm	<b>22'0"</b>	7879 mm	<b>25'10"</b>
Overall operating height	6531 mm	<b>21'5"</b>	6531 mm	<b>21'5"</b>	7375 mm	<b>24'2"</b>
Loading height	4440 mm	<b>14'7"</b>	4440 mm	<b>14'7"</b>	5194 mm	<b>17'0"</b>
17) Loading reach	2175 mm	<b>7'2"</b>	2175 mm	<b>7'2"</b>	3200 mm	<b>10'6"</b>
Swing arc		<b>175°</b>		<b>175°</b>		<b>175°</b>
Bucket rotation		<b>198°</b>		<b>198°</b>		<b>198°</b>
18) Stabilizer spread, operating position (center of pad)	3614 mm	<b>11'10"</b>	3614 mm	<b>11'10"</b>	3614 mm	<b>11'10"</b>
19) Stabilizer spread — operating position (outside edge of pad)	4055 mm	<b>13'4"</b>	4055 mm	<b>13'4"</b>	4055 mm	<b>13'4"</b>
Stabilizer spread, transport position	2451 mm	<b>8'0"</b>	2451 mm	<b>8'0"</b>	2451 mm	<b>8'0"</b>
Bucket dig force	78.9 kN	<b>17,746 lbf</b>	78.9 kN	<b>17,746 lbf</b>	78.9 kN	<b>17,746 lbf</b>
Stick dig force	52.4 kN	<b>11,780 lbf</b>	53.1 kN	<b>11,939 lbf</b>	40.1 kN	<b>9009 lbf</b>
Leveling angle (maximum slope on which machine will make a vertical cut)		<b>13°</b>		<b>13°</b>		<b>13°</b>

# Backhoe Loaders

## Lift Capacities

- 450E

### KEY

- A — Boom lift kg lb
- B — Stick lift kg lb

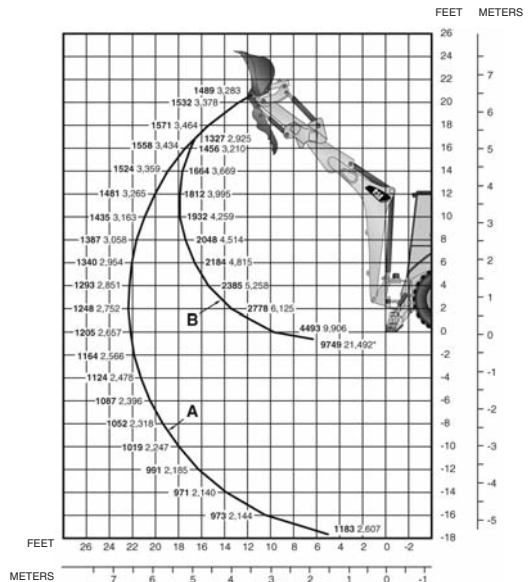
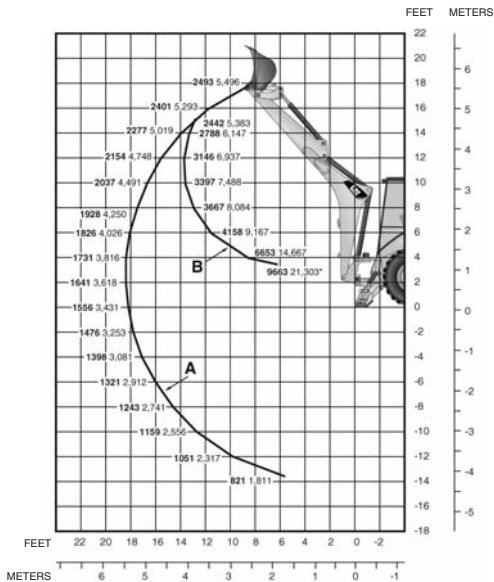
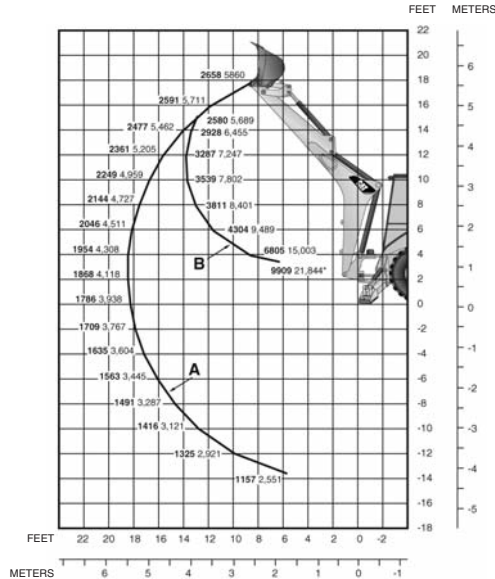

Lift capacities are over-end values per SAE J31; machine equipped with 4WD, OROPS, 1.34 m<sup>3</sup> (1.75 yd<sup>3</sup>) general-purpose loader bucket, 610 mm (24 in) heavy duty backhoe bucket and 454 kg (1000 lb) counterweight. Extendible stick lift capacities include 682 kg (1500 lb) counterweight.

\*Indicates lift capacity is stability limited.

**Standard Duty Buckets (SD)**  
**416E, 420E, 422E2, 428E2, 430E, 432E2, 442E2**

Width		SAE Capacity		Weight		No. of Teeth
mm	in	L	ft <sup>3</sup>	kg	lb	
305	12	71	2.5	111	245	3
457	18	98	3.5	122	268	4
610	24	138	4.9	141	311	5
762	30	178	6.3	157	345	5
914	36	218	7.7	176	388	6

Teeth Options: Penetration  
 Soil  
 Sharp  
 Twin Sharp  
 Chisel  
 Wide  
 Long

**Heavy Duty Buckets (HD)**  
**416E, 420E, 422E2, 428E2, 430E, 432E2, 442E2**

Width		SAE Capacity		Weight		No. of Teeth
mm	in	L	ft <sup>3</sup>	kg	lb	
305	12	71	2.5	121	266	3
406	16	88	3.1	128	282	3
457	18	97	3.4	135	299	4
610	24	138	4.9	160	353	5
762	30	178	6.3	177	391	5
914	36	218	7.7	201	443	6

\*Bolt-on teeth available.

**Soil Excavation Buckets (SE)**  
**416E, 420E, 422E2, 428E2, 430E, 432E2, 442E2**

Width		SAE Capacity		Weight		No. of Teeth
mm	in	L	ft <sup>3</sup>	kg	lb	
457	18	133	4.7	155	341	4
610	24	194	6.9	182	402	5
762	30	249	8.8	206	454	5
914	36	304	10.7	233	513	6

**Extreme Service Buckets (ES)**  
**422E2, 428E2, 432E2, 442E2**

Width		SAE Capacity		Weight		No. of Teeth
mm	in	L	ft <sup>3</sup>	kg	lb	
305	12	64	2.2	106	233	3
457	18	96	3.4	132	291	4
610	24	142	5.2	152	335	4
762	30	189	6.2	177	390	6

**Heavy Duty Buckets (HD)**  
**450E**

Width		SAE Capacity		Weight		No. of Teeth
mm	in	L	ft <sup>3</sup>	kg	lb	
457	18	170	6.0	211	465	3
610	24	240	8.5	252	554	4
762	30	300	10.6	283	625	4
914	36	380	13.4	326	719	6



**Heavy Duty Rock Buckets  
416E, 420E, 430E**

Width		SAE Capacity		Weight		No. of Teeth
mm	in	L	ft <sup>3</sup>	kg	lb	
305	<b>12</b>	61	<b>2.2</b>	127	<b>279</b>	3
457	<b>18</b>	111	<b>3.9</b>	146	<b>322</b>	4
610	<b>24</b>	157	<b>5.5</b>	174	<b>384</b>	5
762	<b>30</b>	203	<b>7.2</b>	197	<b>434</b>	5
914	<b>36</b>	249	<b>8.8</b>	224	<b>493</b>	6

**Pin Lock Buckets, High Capacity  
(North America)**

Width		SAE Capacity		Weight		No. of Teeth
mm	in	L	ft <sup>3</sup>	kg	lb	
305	<b>12</b>	115	<b>4.1</b>	134	<b>295</b>	3
406	<b>16</b>	139	<b>4.9</b>	153	<b>338</b>	3
457	<b>18</b>	154	<b>5.4</b>	162	<b>357</b>	4
610	<b>24</b>	220	<b>7.8</b>	194	<b>427</b>	5
762	<b>30</b>	285	<b>10.1</b>	222	<b>490</b>	5
914	<b>36</b>	351	<b>12.4</b>	254	<b>561</b>	6

**Coral Buckets**

Width		SAE Capacity		Weight		No. of Teeth
mm	in	L	ft <sup>3</sup>	kg	lb	
305	<b>12</b>	55	<b>1.9</b>	134	<b>295</b>	4
457	<b>18</b>	79	<b>2.8</b>	155	<b>341</b>	6
610	<b>24</b>	111	<b>3.9</b>	182	<b>402</b>	8
762	<b>30</b>	145	<b>5.1</b>	210	<b>463</b>	10

**Ditch Cleaning Buckets  
(North America)**

Width		SAE Capacity		Weight		No. of Teeth
mm	in	L	ft <sup>3</sup>	kg	lb	
1219	<b>48</b>	368	<b>13.0</b>	231	<b>510</b>	N/A
1372	<b>54</b>	425	<b>15.0</b>	252	<b>555</b>	N/A
1524	<b>60</b>	481	<b>17.0</b>	272	<b>600</b>	N/A

**Pin Lock Buckets, Heavy Duty  
(North America)**

Width		SAE Capacity		Weight		No. of Teeth
mm	in	L	ft <sup>3</sup>	kg	lb	
305	<b>12</b>	87	<b>3.1</b>	116	<b>257</b>	3
406	<b>16</b>	105	<b>3.7</b>	135	<b>297</b>	3
457	<b>18</b>	117	<b>4.1</b>	142	<b>313</b>	4
610	<b>24</b>	167	<b>5.9</b>	190	<b>418</b>	5
762	<b>30</b>	216	<b>7.6</b>	201	<b>443</b>	5
914	<b>36</b>	266	<b>9.4</b>	231	<b>509</b>	6

**Ditch Cleaning Buckets  
(Europe, Africa, Middle East)**

Width		SAE Capacity		Weight		No. of Teeth
mm	in	L	ft <sup>3</sup>	kg	lb	
1200	<b>48</b>	200	<b>7.8</b>	123	<b>271</b>	N/A
1400	<b>54</b>	260	<b>9.2</b>	137	<b>302</b>	N/A
1500	<b>60</b>	290	<b>10.2</b>	145	<b>320</b>	N/A
1600	<b>63</b>	310	<b>10.9</b>	152	<b>335</b>	N/A
1800	<b>70</b>	350	<b>12.4</b>	166	<b>366</b>	N/A

**Work tools for Cat backhoe loaders are divided into two groups. For technical questions relating to all work tools inside the U.S.: (800) 282-5384. Europe, Africa, Middle East: 31 73 63 996 00.**

- **Caterpillar Factory Work Tools:** Cat work tools installed on machines or shipped separately from Cat Distribution Services. Includes the most popular work tools such as buckets, forks and material-handling arms. *Order from Machine Orders Division.*
- **Cat Work Tools America Asia Pacific (AAP):** Cat work tools specifically designed for the Cat backhoe loader by the Cat Work Tool division. *Orders inside U.S.: (800) 255-2372. Outside U.S.: 00 1 (785) 456-2224.*

Loader Work Tools	Auxiliary Hydraulics required
1. IT Angle Blade	Multi-Purpose Hydraulics included with IT not required
2. IT Asphalt Cutter	not required
3. IT Bale Spear	Multi-Purpose Hydraulics included with IT not required
4. IT Broom: Angle and Pick-up*	Multi-Purpose Hydraulics included with IT not required
5. IT Bucket, General Purpose	Multi-Purpose Hydraulics included with IT not required
6. IT Bucket, Multi-Purpose	Multi-Purpose Hydraulics included with IT not required
7. IT Bucket, Side-Dump	Multi-Purpose Hydraulics included with IT not required
8. IT Forks, Pallet	not required
9. IT Material Handling Arm	not required
10. IT Rake	not required
11. Quick Coupler, IT Hydraulic	Multi-Purpose Hydraulics not required
12. Single Tilt Bucket, General Purpose	Multi-Purpose Hydraulics includes coupling hydraulics only; can add Multi-Purpose Hydraulics
13. Single Tilt Bucket, Multi-Purpose with or without Fold-Over Forks	
14. Single Tilt Hydraulic Quick Coupler	

\*Requires the IT Auxiliary Attachments Control (electrical wiring harness).

Backhoe Work Tools	Auxiliary Hydraulics required
1. Auger	Combined Function Hydraulics not required
2. Bucket, Cemetery	not required
3. Bucket, Coral	not required
4. Bucket, Ditch Cleaning	not required
5. Bucket, Extreme Service	not required
6. Bucket, Heavy Duty	not required
7. Bucket, Heavy Duty Rock	not required
8. Bucket, High Capacity	not required
9. Bucket, Soil Excavation	not required
10. Bucket, Standard Duty	not required
11. Compactor, Vibratory Plate	One Way or Combined Function Hydraulics
12. Hammer, Hydraulic	One Way or Combined Function Hydraulics not required
13. Quick Coupler, Mechanical Pin-Puller for Cat or Case tools	not required
14. Quick Coupler, Mechanical Pin-Grabber	not required
15. Quick Coupler, Mechanical Pin-Puller for Cat or Deere tools	not required
16. Quick Coupler, Pin Lock	not required
17. Quick Coupler, Side-Tilting Pin Lock	Combined Function Hydraulics not required
18. Ripper	Combined Function Hydraulics not required
19. Thumb, Hydraulic	Combined Function Hydraulics not required
20. Thumb, Mechanical	not required



# FOREST PRODUCTS

## CONTENTS

### HARVESTING

Track Harvesters	
Sustainability . . . . .	6-2
Features . . . . .	6-2
Specifications . . . . .	6-3
Dimensions . . . . .	6-5
Shipping Dimensions . . . . .	6-6
Range Diagrams . . . . .	6-7
Track Feller Bunchers	
Features . . . . .	6-8
Specifications . . . . .	6-9
Shipping Dimensions . . . . .	6-11
Range Diagrams . . . . .	6-14
Wheel Feller Bunchers	
Features . . . . .	6-16
Specifications . . . . .	6-16
Dimensions . . . . .	6-17
Wheel Harvester	
Sustainability . . . . .	6-18
Features . . . . .	6-18
Specifications . . . . .	6-18
Dimensions with Standard Boom . . . . .	6-19
Felling Heads	
Specifications . . . . .	6-20

### WOOD EXTRACTION

Wheel Skidders	
Features . . . . .	6-21
Specifications . . . . .	6-22
Dimensions . . . . .	6-23
Grapple: Single-Function Arch . . . . .	6-24
Application . . . . .	6-25
Continuous Rotate . . . . .	6-26
Track Skidders	
Features . . . . .	6-28
Specifications . . . . .	6-29
Shoe Selection and Ground Pressure . . . . .	6-30
Winch Specifications . . . . .	6-30
Dimensions . . . . .	6-31
Drawbar Pull . . . . .	6-33
Grapple Specifications . . . . .	6-34
Forwarders	
Sustainability . . . . .	6-36
Features . . . . .	6-36
Specifications . . . . .	6-36
Dimensions . . . . .	6-38

### PROCESSING/LOADING

Forest Machines	
Features . . . . .	6-40
Specifications . . . . .	6-41
Working Ranges . . . . .	6-45
Shipping Dimensions . . . . .	6-49
324D FM Low Ground Pressure	
Specifications . . . . .	6-53
Trailer Mount Knuckleboom Loaders	
Features . . . . .	6-54
Specifications . . . . .	6-54
Dimensions . . . . .	6-55
Lift and Range Diagrams . . . . .	6-56

### MILLYARDS

Stationary Mount Knuckleboom Loaders	
Features . . . . .	6-61
Specifications . . . . .	6-61
Dimensions . . . . .	6-62
Lift and Range Diagrams . . . . .	6-63
Wheel Loaders and Integrated Toolcarriers	
Forestry Features . . . . .	6-67
Forestry Specifications . . . . .	6-67
Load Capacity Curves . . . . .	6-68

### WORK TOOLS

Grapples for Heel Boom Log Loaders	
Features . . . . .	6-74
Dimensions . . . . .	6-75
Logging Forks	
Features . . . . .	6-76
Specifications . . . . .	6-76
Couplers	
Features . . . . .	6-79
Buckets and Thumbs	
Features . . . . .	6-79
Woodchip Dozers and Scoops	
Features . . . . .	6-80
Specifications . . . . .	6-80
Rakes	
Features . . . . .	6-81

### TABLES

Log Volume Tables . . . . .	6-82
Weights of Commercially Important Woods . . . . .	6-84
Estimating Number of Trees . . . . .	6-87
Comparison of Log Rules . . . . .	6-87
Measurement Definitions . . . . .	6-88
Cubic Feet of Solid Wood per Cord . . . . .	6-88
Rule of Thumb Conversions . . . . .	6-88

**Sustainability:**

- **Major structures and components** are built to be rebuilt, reducing waste and replacement costs.
- **ACERT™ Technology** reduces engine emissions at point of combustion with less moving parts for lower operating costs.

**501/501 HD — Track Harvester Features:**

- **Cat® C6.6 ACERT Technology** provides excellent fuel economy and meets Tier 3 emission standards.
- **Optional 8.2 m (27 ft) telescopic boom** provides additional reach.
- **Unique front entry cab** allows for easy entry and exit.
- **Tilt cab** provides easy service.
- **Proven x-design carbody and large track system** provide strength and durability.
- **Large heavy-duty swing bearing and swing torque** enhance productivity.
- **Exceptional operator visibility.**
- **IQAN computer based control system** provides precise control of machine and attachment functions.

**511/521/522/532 —**

**Zero Tail Swing Track Harvester Features:**

- **Cat C9 ACERT Tier 2 high torque engine** provides excellent power, fuel economy, serviceability and durability.
- **The most robust tilt mechanism** in the industry, the tilting models (522/532) have a patented 3-cylinder tilt mechanism with simultaneous tilting forward and side-to-side.
- **Proven rugged undercarriage** designed for the toughest harvesting conditions ranging from wet bottomlands to steep rocky slopes.
- **Hydraulically actuated clam-shell service door** provides full access and reduces maintenance down time.
- **Comfortable, purpose built forestry cab** with heavy duty guarding meets FOPS/ROPS/OPS requirements.

- **Flexaire fan (attachment)** allows the cooling fan to purge debris from the radiator area minimizing cooling system maintenance.
- **Hydraulic system** is easily interchangeable with felling intermittent or harvesting linkage fronts.
- **IQAN display** allows the operator to continuously monitor the machine and get early warning for potential problems.
- **Ergonomically located pedals with side-by-side foot rests** provide maximum operator comfort when the machine is traveling.

**541/551/552 —**

**Full Tail Swing Track Harvester Features:**

- **Cat C9 ACERT Tier 2 high torque engine** provides excellent power, fuel economy, serviceability and durability.
- **The most robust tilt mechanism** in the industry, the tilting model (552) has a patented 3-cylinder tilt mechanism with simultaneous tilting forward and side-to-side.
- **Proven rugged undercarriage** designed for the toughest harvesting conditions ranging from wet bottomlands to steep rocky slopes.
- **Hydraulically actuated dual service door** provides engine/hydraulic access direct from the cab.
- **Walk through service access** minimizes service time and down time costs.
- **Comfortable, purpose built forestry cab** with heavy duty guarding meets FOPS/ROPS/OPS requirements.
- **Hydraulic system** is easily interchangeable with felling intermittent or harvesting linkage fronts.
- **IQAN display** allows the operator to continuously monitor the machine and get early warning for potential problems.
- **Ergonomically located pedals with side-by-side foot rests** provide maximum operator comfort when the machine is traveling.
- **Flexaire fan (standard)** allows the cooling fan to purge debris from the radiator area minimizing cooling system maintenance.

**Track Harvesters  
MODEL**

	<b>501</b>		<b>501 HD</b>	
Gross Power	117 kW	<b>157 hp</b>	117 kW	<b>157 hp</b>
Operating Weight (without attachment)	15 900 kg	<b>35,000 lb</b>	18 000 kg	<b>40,000 lb</b>
Engine Model	<b>C6.6 ACERT Tier 3</b>		<b>C6.6 ACERT Tier 3</b>	
Tractive Effort	16 621 kg	<b>36,600 lb</b>	19 686 kg	<b>43,400 lb</b>
Undercarriage:				
Size	<b>D4</b>		<b>D5</b>	
Pitch	171.4 mm	<b>6.7"</b>	190.5 mm	<b>7.5"</b>
Maximum Reach (with head)	7087 mm	<b>23'3"</b>	8200 mm	<b>27'0"</b>
Minimum Reach (with head)	3658 mm	<b>12'0"</b>	3658 mm	<b>12'0"</b>
Fuel Capacity	378 L	<b>100 U.S. gal</b>	378 L	<b>100 U.S. gal</b>
Hydraulic System	545 bar	<b>5000 psi</b>	545 bar	<b>5000 psi</b>
Hydraulic Oil Flow	307 L/min	<b>81 gpm</b>	307 L/min	<b>81 gpm</b>
Hydraulic Oil Reservoir	230 L	<b>60 U.S. gal</b>	230 L	<b>60 U.S. gal</b>
General Dimensions:				
Height (with standard pads)	3327 mm	<b>10'11"</b>	3429 mm	<b>11'3"</b>
Width (with 560 mm/22" pads)	2591 mm	<b>8'6"</b>	—	—
Width (with 610 mm/24" pads)	—	—	2845 mm	<b>9'4"</b>

**ZTS (Zero Tail Swing)  
MODEL**

	<b>511</b>		<b>521</b>		<b>522</b>		<b>532</b>	
Rated Power @ 2100 RPM	170 kW	<b>228 hp</b>	196.1 kW	<b>263 hp</b>	196.1 kW	<b>263 hp</b>	196.1 kW	<b>263 hp</b>
Gross Power @ 1800 RPM	184 kW	<b>247 hp</b>	212 kW	<b>284 hp</b>	212 kW	<b>284 hp</b>	212 kW	<b>284 hp</b>
Operating Weight (without head)	23 790 kg	<b>52,440 lb</b>	26 050 kg	<b>57,440 lb</b>	29 806 kg	<b>65,710 lb</b>	31 450 kg	<b>69,340 lb</b>
Engine Model	<b>C9 ACERT</b>		<b>C9 ACERT</b>		<b>C9 ACERT</b>		<b>C9 ACERT</b>	
Displacement	8.8 L	<b>537 in³</b>	8.8 L	<b>537 in³</b>	8.8 L	<b>537 in³</b>	8.8 L	<b>537 in³</b>
Tractive Effort	30 391 kg	<b>67,000 lb</b>	31 978 kg	<b>70,500 lb</b>	34 246 kg	<b>75,500 lb</b>	38 555 kg	<b>85,000 lb</b>
Undercarriage:								
Size	<b>325 HEX</b>		<b>D6H HD</b>		<b>D6H HD</b>		<b>330 HEX</b>	
Pitch	203.2 mm	<b>8.0"</b>	203.2 mm	<b>8.0"</b>	203.2 mm	<b>8.0"</b>	215.9 mm	<b>8.5"</b>
Track Gauge	2591 mm	<b>102"</b>	2591 mm	<b>102"</b>	2591-2870 mm	<b>102-113"</b>	2591-2870 mm	<b>102-113"</b>
Swing Torque	82.7 kN·m	<b>61,000 lb</b>	82.7 kN·m	<b>61,000 lb</b>	82.7 kN·m	<b>61,000 lb</b>	82.7 kN·m	<b>61,000 lb</b>
Swing Speed	<b>6.8 rpm</b>		<b>6.8 rpm</b>		<b>6.8 rpm</b>		<b>6.8 rpm</b>	
Maximum Reach (with head)*	9.8 m	<b>32'0"</b>	9.8 m	<b>32'0"</b>	9.8 m	<b>32'0"</b>	9.8 m	<b>32'0"</b>
Bare Pin Lift @ Maximum Reach (without head)	4100 kg @ 9 m	<b>9100 lb @ 29'6"</b>	4100 kg @ 9 m	<b>9100 lb @ 29'6"</b>	4100 kg @ 9 m	<b>9100 lb @ 29'6"</b>	4100 kg @ 9 m	<b>9100 lb @ 29'6"</b>
Track Length	4572 mm	<b>180"</b>	4801 mm	<b>189"</b>	4801 mm	<b>189"</b>	4877 mm	<b>192"</b>
Fuel Capacity	530 L	<b>140 U.S. gal</b>	530 L	<b>140 U.S. gal</b>	530 L	<b>140 U.S. gal</b>	530 L	<b>140 U.S. gal</b>
Hydraulic System:								
Oil Fill Pump	<b>Electric</b>		<b>Electric</b>		<b>Electric</b>		<b>Electric</b>	
Variable Displacement Pumps:								
Travel and Tilt Functions	379 L	<b>100 gpm</b>	416 L	<b>110 gpm</b>	416 L	<b>110 gpm</b>	416 L	<b>110 gpm</b>
Boom and Implement Functions	379 L	<b>100 gpm</b>	398 L	<b>105 gpm</b>	398 L	<b>105 gpm</b>	398 L	<b>105 gpm</b>
Saw Pump (when equipped)	114 L	<b>30 gpm</b>	114 L	<b>30 gpm</b>	114 L	<b>30 gpm</b>	114 L	<b>30 gpm</b>
General Dimensions:								
Ground Clearance	762 mm	<b>30"</b>	838 mm	<b>33"</b>	838 mm	<b>33"</b>	889 mm	<b>35"</b>
Width (with 610 mm/24" Track Shoe)	3200 mm	<b>126"</b>	3200 mm	<b>126"</b>	3200 mm	<b>126"</b>	3200 mm	<b>126"</b>
Adjustable to	—	—	—	—	3480 mm	<b>137"</b>	3480 mm	<b>137"</b>
Height (to top of cab with standard skylight)	3378 mm	<b>133"</b>	3556 mm	<b>140"</b>	3861 mm	<b>152"</b>	3962 mm	<b>156"</b>
Tail Swing (with Counterweight)	1929 mm	<b>6'4"</b>	1929 mm	<b>6'4"</b>	1929 mm	<b>6'4"</b>	1929 mm	<b>6'4"</b>

\*Lift over front of tracks.

**FTS (Full Tail Swing)  
MODEL**

	<b>541</b>		<b>551</b>		<b>552</b>	
Rated Power @ 2100 RPM	210 kW	<b>282 hp</b>	210 kW	<b>282 hp</b>	210 kW	<b>282 hp</b>
Gross Power @ 1800 RPM	227 kW	<b>305 hp</b>	227 kW	<b>305 hp</b>	227 kW	<b>305 hp</b>
Engine Model	<b>C9 ACERT</b>		<b>C9 ACERT</b>		<b>C9 ACERT</b>	
Displacement	8.8 L	<b>537 in<sup>3</sup></b>	8.8 L	<b>537 in<sup>3</sup></b>	8.8 L	<b>537 in<sup>3</sup></b>
Tractive Effort	34 246 kg	<b>75,500 lb</b>	47 174 kg	<b>104,000 lb</b>	47 174 kg	<b>104,000 lb</b>
Undercarriage:						
Size	<b>330 HEX</b>		<b>345 HEX</b>		<b>345 HEX</b>	
Pitch	215.9 mm	<b>8.5"</b>	215.9 mm	<b>8.5"</b>	215.9 mm	<b>8.5"</b>
Track Gauge	2591-2870 mm	<b>102-113"</b>	2591-2870 mm	<b>102-113"</b>	2591-2870 mm	<b>102-113"</b>
Swing Torque	97.6 kN·m	<b>72,000 lb</b>	97.6 kN·m	<b>72,000 lb</b>	97.6 kN·m	<b>72,000 lb</b>
Swing Speed	<b>6.8 rpm</b>		<b>6.8 rpm</b>		<b>6.8 rpm</b>	
Maximum Reach (with head)	11.3 m	<b>37'0"</b>	11.3 m	<b>37'0"</b>	11.3 m	<b>37'0"</b>
Bare Pin Lift @ Maximum Reach (without head)*	4300 kg @ 10.7 m	<b>9500 lb @ 35'0"</b>	5000 kg @ 10.7 m	<b>11,000 lb @ 35'0"</b>	5700 kg @ 10.7 m	<b>12,500 lb @ 35'0"</b>
Track Length	4893 mm	<b>192.6"</b>	4904 mm	<b>193"</b>	4903 mm	<b>193"</b>
Fuel Capacity	1181 L	<b>312 U.S. gal</b>	1181 L	<b>312 U.S. gal</b>	1181 L	<b>312 U.S. gal</b>
Hydraulic System:						
Oil Fill Pump	<b>Electric</b>		<b>Electric</b>		<b>Electric</b>	
Variable Displacement Pumps:						
Travel and Implement Functions	416 L	<b>110 gpm</b>	416 L	<b>110 gpm</b>	416 L	<b>110 gpm</b>
Saw Pump	114 L	<b>30 gpm</b>	114 L	<b>30 gpm</b>	114 L	<b>30 gpm</b>
General Dimensions:						
Ground Clearance	889 mm	<b>35"</b>	889 mm	<b>35"</b>	889 mm	<b>35"</b>
Width (with 711 mm/28" Track Shoe)	3327 mm	<b>131"</b>	3327 mm	<b>131"</b>	3327 mm	<b>131"</b>
Adjustable to	3607 mm	<b>142"</b>	3607 mm	<b>142"</b>	3607 mm	<b>142"</b>
Height (to top of cab with standard skylight)	3556 mm	<b>140"</b>	3658 mm	<b>144"</b>	3962 mm	<b>156"</b>
Tail Swing	2743 mm	<b>9'0"</b>	2743 mm	<b>9'0"</b>	2743 mm	<b>9'0"</b>

\*Lift over front of tracks.

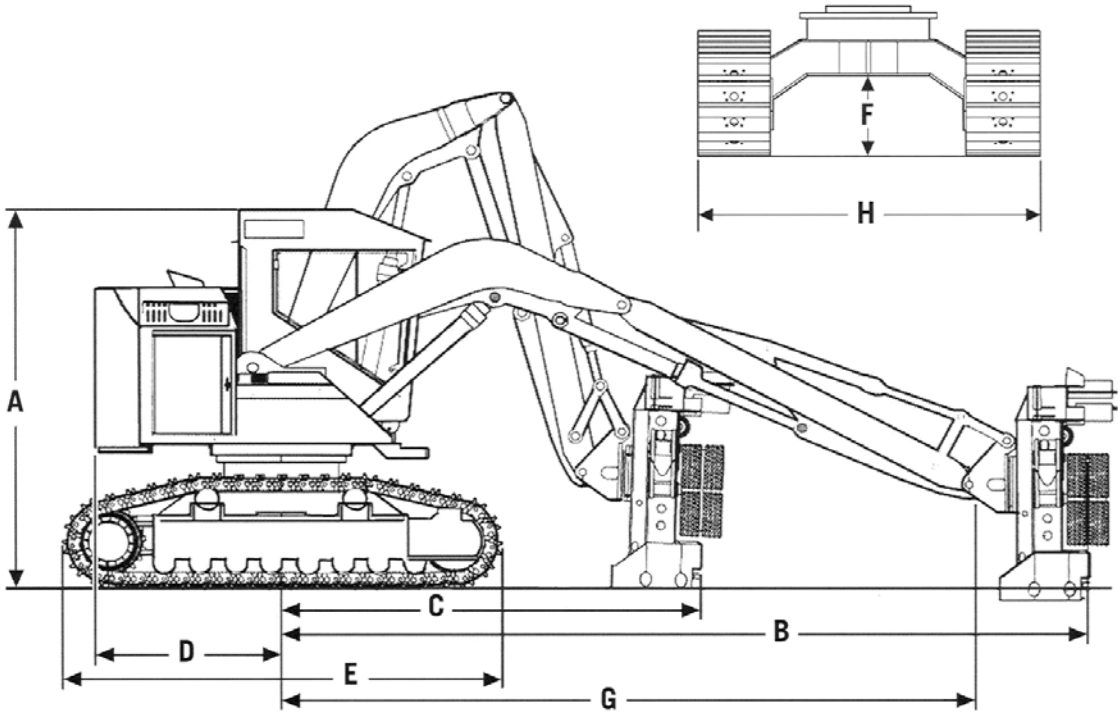

MODEL	501		501 HD	
<b>A</b> Height with Standard pads	3327 mm	10'11"	3429 mm	11'3"
<b>B</b> Maximum Reach (Standard boom) with Prentice PF-48 Processor	6401 mm	21'0"	7087 mm	23'3"
<b>C</b> Minimum Reach (Standard boom) with Prentice PF-48 Processor	3658 mm	12'0"	3658 mm	12'0"
<b>D</b> Swing Center to Rear of Counterweight	1645 mm	64.75"	1645 mm	64.75"
<b>E</b> Undercarriage Length	3632 mm	11'10"	3962 mm	13'0"
<b>F</b> Ground Clearance	610 mm	24"	660 mm	26"
<b>G</b> Reach to Stick Boom Pin	5359 mm	17'7"	6045 mm	19'10"
<b>H</b> Width*	2591 mm	8'6"	2845 mm	9'4"

\*501 with 560 mm (22") pads.  
501 HD with 610 mm (24") pads.



These illustrations and values are ESTIMATED for TRUCK SHIPMENT ONLY FROM THE FACTORY.  
These are subject to change based on attachments, configurations, add-ons, etc.

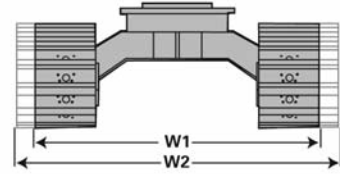

**522/532 (Tilter) Track Harvesters**

**511/521 (Non-Tilter) Track Harvesters**

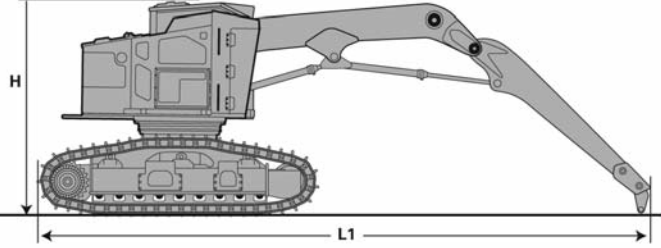
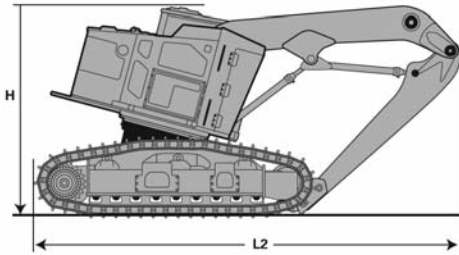

**552 (Tilter) Track Harvesters**

**541/551 (Non-Tilter) FTS Track Harvesters**

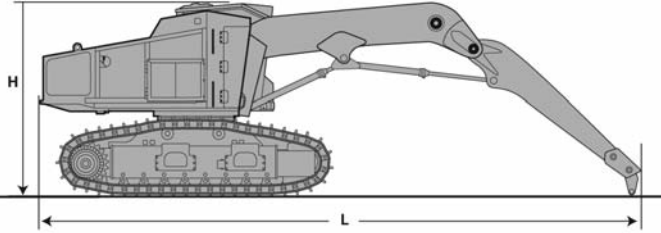
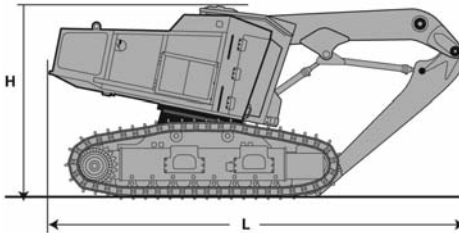

**ZTS Track Harvesters Shipping Dimensions**

MODEL	Length 1	Length 2	Height*	Width 1+	Width 2++	Weight
<b>511</b>	11 328 mm <b>446"</b>	—	3378 mm <b>133"</b>	3200 mm <b>126"</b>	—	23 950 kg <b>52,800 lb</b>
<b>521</b>	11 506 mm <b>453"</b>	—	3556 mm <b>140"</b>	3200 mm <b>126"</b>	—	26 217 kg <b>57,800 lb</b>
<b>522**</b>	—	8077 mm <b>318"</b>	3861 mm <b>152"</b>	3200 mm <b>126"</b>	3480 mm <b>137"</b>	30 917 kg <b>68,160 lb</b>
<b>532**</b>	—	8077 mm <b>318"</b>	3962 mm <b>156"</b>	3200 mm <b>126"</b>	3480 mm <b>137"</b>	31 933 kg <b>70,400 lb</b>

Length, Height and Width 1 assume 610 mm (24") Single Grouser shoes.

\*Height to top of cab with standard skylight.

\*\*Boom tucked.

+Width 1 is minimum width with 610 mm (24") Single Grouser shoes.

++Width 2 is maximum width when undercarriage is set wide.

**FTS Track Harvesters Shipping Dimensions**

MODEL	Length	Height*	Width 1+	Width 2++	Weight
<b>541</b>	13 614 mm <b>536"</b>	3556 mm <b>140"</b>	3327 mm <b>131"</b>	3607 mm <b>142"</b>	30 512 kg <b>67,267 lb</b>
<b>551</b>	13 614 mm <b>536"</b>	3658 mm <b>144"</b>	3327 mm <b>131"</b>	3607 mm <b>142"</b>	31 377 kg <b>69,175 lb</b>
<b>552**</b>	7010 mm <b>276"</b>	3962 mm <b>156"</b>	3327 mm <b>131"</b>	3607 mm <b>142"</b>	36 000 kg <b>79,367 lb</b>

Length, Height and Width assume 711 mm (28") Single Grouser shoes.

\*Height to top of cab with standard skylight.

\*\*Boom tucked.

+Width 1 is minimum width with 711 mm (28") Single Grouser shoes.

++Width 2 is maximum width when undercarriage is set wide.

**Lift Range Information — Harvesting Linkage  
511/521/522/532 — ZTS**

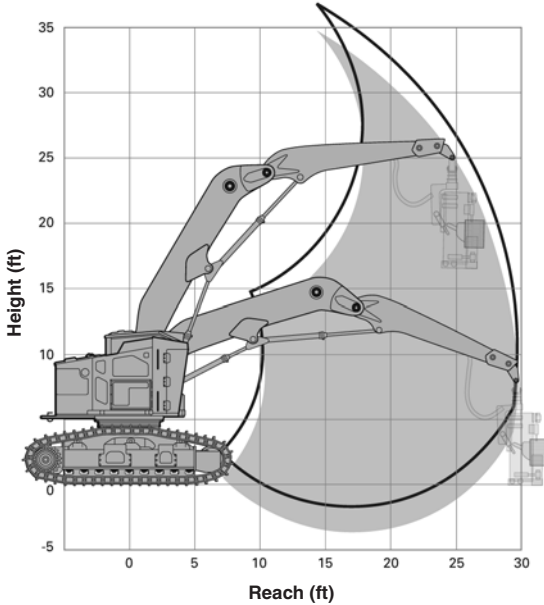

**Lift Range Information — Harvesting Linkage  
541/551/552 — FTS**

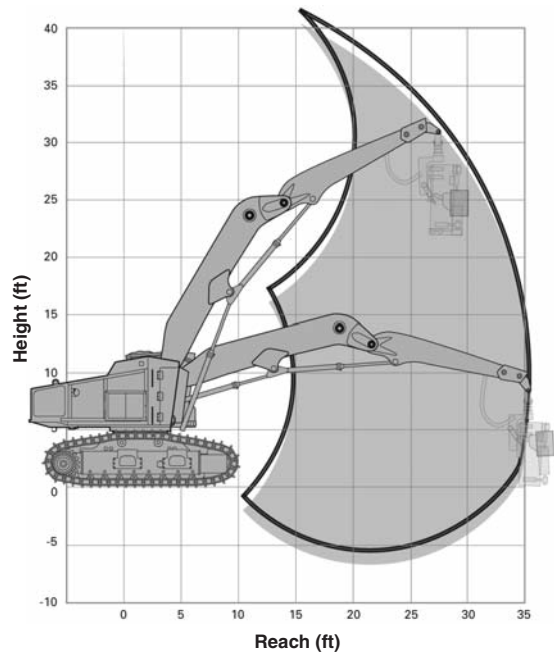

NOTE: \_\_\_\_ Line represents Tilter Model.

**Lift Over Front of Tracks**

MODEL	511		521		522		532	
Reach	Lift Capacity		Lift Capacity		Lift Capacity		Lift Capacity	
3 m (10'0")	4500 kg	10,000 lb	4500 kg	10,000 lb	4500 kg	10,000 lb	4500 kg	10,000 lb
6.1 m (20'0")	6900 kg	15,200 lb	6900 kg	15,200 lb	6900 kg	15,200 lb	6900 kg	15,200 lb
9.0 m (29'6")	4100 kg	9100 lb	4100 kg	9100 lb	4100 kg	9100 lb	4100 kg	9100 lb
MODEL	541		551		552			
Reach	Lift Capacity		Lift Capacity		Lift Capacity			
4.5 m (15'0")	9100 kg	20,200 lb	9100 kg	20,200 lb	9100 kg	20,200 lb		
7.6 m (25'0")	7100 kg	15,700 lb	8200 kg	18,100 lb	9400 kg	20,600 lb		
10.7 m (35'0")	4300 kg	9500 lb	5000 kg	11,000 lb	5700 kg	12,500 lb		

**Lift Over Side of Tracks**

MODEL	511		521		522		532	
Reach	Lift Capacity		Lift Capacity		Lift Capacity		Lift Capacity	
3 m (10'0")	4500 kg	10,000 lb	4500 kg	10,000 lb	4500 kg	10,000 lb	4500 kg	10,000 lb
6.1 m (20'0")	5300 kg	11,600 lb	5900 kg	13,000 lb	6900 kg	15,200 lb	6900 kg	15,200 lb
9.0 m (29'6")	2900 kg	6300 lb	3300 kg	7200 lb	4100 kg	9100 lb	4100 kg	9100 lb
MODEL	541		551		552			
Reach	Lift Capacity		Lift Capacity		Lift Capacity			
4.5 m (15'0")	9100 kg	20,200 lb	9100 kg	20,200 lb	9100 kg	20,200 lb		
7.6 m (25'0")	4500 kg	9900 lb	5700 kg	12,500 lb	6500 kg	14,300 lb		
10.7 m (35'0")	2700 kg	5900 lb	3400 kg	7600 lb	4000 kg	8800 lb		

NOTE: Lift Capacity shown without attachment.  
Additional reach and attachment weight will reduce lift capacity.

**511/521/522/532 —**

**Zero Tail Swing Track Feller Buncher Features:**

- **Cat C9 ACERT Tier 2 high torque engine provides** excellent power, fuel economy, serviceability and durability.
- **A robust tilt mechanism**, the tilting models (522/532) have a patented 3-cylinder tilt mechanism with simultaneous tilting forward and side-to-side.
- **Proven rugged undercarriage** designed for the toughest harvesting conditions ranging from wet bottomlands to steep rocky slopes.
- **Hydraulically actuated clam-shell service door** provides full service and reduces maintenance down time.
- **Comfortable, purpose built forestry cab** with heavy duty guarding meets FOPS/ROPS/OPS requirements.
- **Flexaire fan (attachment)** allows the cooling fan to purge debris from the radiator area minimizing cooling system maintenance.
- **Felling heads and processing heads** utilize high pressure hydraulics and proven components to meet your application requirements.
- **IQAN display** allows the operator to continuously monitor the machine and get early warning for potential problems.
- **Ergonomically located pedals with side-by-side foot rests** provide maximum operator comfort when the machine is traveling.

**541/551/552 —**

**Full Tail Swing Track Feller Buncher Features:**

- **Cat C9 ACERT Tier 2 high torque engine provides** excellent power, fuel economy, serviceability and durability.
- **The most robust tilt mechanism** in the industry, the tilting model (552) have a patented 3-cylinder tilt mechanism with simultaneous tilting forward and side-to-side.
- **Proven rugged undercarriage** designed for the toughest harvesting conditions ranging from wet bottomlands to steep rocky slopes.
- **Hydraulically actuated dual service door** provides engine/hydraulic access direct from the cab.
- **Walk through service access** minimizes service time and down time costs.
- **Comfortable, purpose built forestry cab** with heavy duty guarding meets FOPS/ROPS/OPS requirements.
- **Hydraulic packages** can be included for operation with an intermittent saw and high speed disc saw.
- **Optional 9.4 m (30'10") harvester boom and hydraulic packages** available for dangle mount harvesting heads.
- **IQAN display** allows the operator to continuously monitor the machine and get early warning for potential problems.
- **Ergonomically located pedals with side-by-side foot rests** provide maximum operator comfort when the machine is traveling.
- **Flexaire fan (standard)** allows the cooling fan to purge debris from the radiator area minimizing cooling system maintenance.

**ZTS (Zero Tail Swing)  
MODEL**

	<b>511</b>		<b>521</b>		<b>522</b>		<b>532</b>	
Rated Power @ 2100 RPM	170 kW	<b>228 hp</b>	196.1 kW	<b>263 hp</b>	196.1 kW	<b>263 hp</b>	196.1 kW	<b>263 hp</b>
Gross Power @ 1800 RPM	184 kW	<b>247 hp</b>	212 kW	<b>284 hp</b>	212 kW	<b>284 hp</b>	212 kW	<b>284 hp</b>
Operating Weight (without head)	24 362 kg	<b>53,710 lb</b>	27 084 kg	<b>59,710 lb</b>	30 410 kg	<b>67,040 lb</b>	31 620 kg	<b>69,710 lb</b>
Engine Model	<b>C9 ACERT</b>		<b>C9 ACERT</b>		<b>C9 ACERT</b>		<b>C9 ACERT</b>	
Displacement	8.8 L	<b>537 in<sup>3</sup></b>	8.8 L	<b>537 in<sup>3</sup></b>	8.8 L	<b>537 in<sup>3</sup></b>	8.8 L	<b>537 in<sup>3</sup></b>
Tractive Effort	30 391 kg	<b>67,000 lb</b>	31 978 kg	<b>70,500 lb</b>	34 246 kg	<b>75,500 lb</b>	38 555 kg	<b>85,000 lb</b>
Undercarriage:								
Size	<b>325 HEX</b>		<b>D6H HD</b>		<b>D6H HD</b>		<b>330 HEX</b>	
Pitch	203.2 mm	<b>8.0"</b>	203.2 mm	<b>8.0"</b>	203.2 mm	<b>8.0"</b>	215.9 mm	<b>8.5"</b>
Track Gauge	2591 mm	<b>102"</b>	2591 mm	<b>102"</b>	2591- 2870 mm	<b>102-113"</b>	2591- 2870 mm	<b>102-113"</b>
Swing Torque	82.7 kN·m	<b>61,000 lb</b>	82.7 kN·m	<b>61,000 lb</b>	82.7 kN·m	<b>61,000 lb</b>	82.7 kN·m	<b>61,000 lb</b>
Swing Speed	<b>6.8 rpm</b>		<b>6.8 rpm</b>		<b>6.8 rpm</b>		<b>6.8 rpm</b>	
Maximum Reach (with head)	8.1 m	<b>26'6"</b>	8.1 m	<b>26'6"</b>	8.1 m	<b>26'6"</b>	8.1 m	<b>26'6"</b>
Bare Pin Lift @ Maximum Reach (without head)*	7100 kg @ 6.1 m	<b>15,600 lb @ 20'0"</b>	7100 kg @ 6.1 m	<b>15,600 lb @ 20'0"</b>	7100 kg @ 6.1 m	<b>15,600 lb @ 20'0"</b>	7100 kg @ 6.1 m	<b>15,600 lb @ 20'0"</b>
Track Length	4572 mm	<b>180"</b>	4801 mm	<b>189"</b>	4801 mm	<b>189"</b>	4877 mm	<b>192"</b>
Fuel Capacity	530 L	<b>140 U.S. gal</b>	530 L	<b>140 U.S. gal</b>	530 L	<b>140 U.S. gal</b>	530 L	<b>140 U.S. gal</b>
Hydraulic System:								
Oil Fill Pump	<b>Electric</b>		<b>Electric</b>		<b>Electric</b>		<b>Electric</b>	
Variable Displacement Pumps:								
Travel and Tilt Functions	379 L	<b>100 gpm</b>	416 L	<b>110 gpm</b>	416 L	<b>110 gpm</b>	416 L	<b>110 gpm</b>
Boom and Implement Functions	379 L	<b>100 gpm</b>	398 L	<b>105 gpm</b>	398 L	<b>105 gpm</b>	398 L	<b>105 gpm</b>
Saw Pump	114 L	<b>30 gpm</b>	114 L	<b>30 gpm</b>	114 L	<b>30 gpm</b>	114 L	<b>30 gpm</b>
General Dimensions:								
Ground Clearance	762 mm	<b>30"</b>	838 mm	<b>33"</b>	838 mm	<b>33"</b>	889 mm	<b>35"</b>
Width (with 610 mm/24" Track Shoe)	3200 mm	<b>126"</b>	3200 mm	<b>126"</b>	3200 mm	<b>126"</b>	3200 mm	<b>126"</b>
Adjustable to	—		—		3480 mm	<b>137"</b>	3480 mm	<b>137"</b>
Height (to top of cab with standard skylight)	3378 mm	<b>133"</b>	3556 mm	<b>140"</b>	3861 mm	<b>152"</b>	3962 mm	<b>156"</b>
Tail Swing (with Counterweight)	1929 mm	<b>6'4"</b>	1929 mm	<b>6'4"</b>	1929 mm	<b>6'4"</b>	1929 mm	<b>6'4"</b>

\*Lift over front of tracks.

<b>FTS (Full Tail Swing) MODEL</b>	<b>541</b>		<b>551</b>		<b>552</b>	
Rated Power @ 2100 RPM	210 kW	<b>282 hp</b>	210 kW	<b>282 hp</b>	210 kW	<b>282 hp</b>
Gross Power @ 1800 RPM	227 kW	<b>305 hp</b>	227 kW	<b>305 hp</b>	227 kW	<b>305 hp</b>
Operating Weight (without head) — Standard Linkage	30 191 kg	<b>66,560 lb</b>	31 057 kg	<b>68,468 lb</b>	35 680 kg	<b>78,660 lb</b>
Operating Weight (without head) — Long Felling Linkage	30 499 kg	<b>67,239 lb</b>	31 365 kg	<b>69,147 lb</b>	35 988 kg	<b>79,339 lb</b>
Engine Model	<b>C9 ACERT</b>		<b>C9 ACERT</b>		<b>C9 ACERT</b>	
Displacement	8.8 L	<b>537 in<sup>3</sup></b>	8.8 L	<b>537 in<sup>3</sup></b>	8.8 L	<b>537 in<sup>3</sup></b>
Tractive Effort	34 246 kg	<b>75,500 lb</b>	47 174 kg	<b>104,000 lb</b>	47 174 kg	<b>104,000 lb</b>
Undercarriage:						
Size	<b>330 HEX</b>		<b>345 HEX</b>		<b>345 HEX</b>	
Pitch	215.9 mm	<b>8.5"</b>	215.9 mm	<b>8.5"</b>	215.9 mm	<b>8.5"</b>
Track Gauge	2591-2870 mm	<b>102-113"</b>	2591-2870 mm	<b>102-113"</b>	2591-2870 mm	<b>102-113"</b>
Swing Torque	97.6 kN-m	<b>72,000 lb</b>	97.6 kN-m	<b>72,000 lb</b>	97.6 kN-m	<b>72,000 lb</b>
Swing Speed	<b>6.8 rpm</b>		<b>6.8 rpm</b>		<b>6.8 rpm</b>	
Maximum Reach (with head)	8.6 m	<b>28'1"</b>	8.6 m	<b>28'1"</b>	8.6 m	<b>28'1"</b>
Bare Pin Lift @ Maximum Reach (without head)*	9400 kg @ 6.6 m	<b>21,800 lb</b> <b>@ 21'6"</b>	9400 kg @ 6.6 m	<b>21,800 lb</b> <b>@ 21'6"</b>	9400 kg @ 6.6 m	<b>21,800 lb</b> <b>@ 21'6"</b>
Bare Pin Lift @ Maximum Reach (without head)**	6400 kg @ 8.2 m	<b>14,200 lb</b> <b>@ 27'0"</b>	7400 kg @ 8.2 m	<b>16,300 lb</b> <b>@ 27'0"</b>	7700 kg @ 8.2 m	<b>16,900 lb</b> <b>@ 27'0"</b>
Track Length	4893 mm	<b>192.6"</b>	4903 mm	<b>193"</b>	4903 mm	<b>193"</b>
Fuel Capacity	1181 L	<b>312 U.S. gal</b>	1181 L	<b>312 U.S. gal</b>	1181 L	<b>312 U.S. gal</b>
Hydraulic System:						
Oil Fill Pump	<b>Electric</b>		<b>Electric</b>		<b>Electric</b>	
Variable Displacement Pumps:						
Travel and Implement Functions (x2)	416 L	<b>110 gpm</b>	416 L	<b>110 gpm</b>	416 L	<b>110 gpm</b>
Saw Pump	114 L	<b>30 gpm</b>	114 L	<b>30 gpm</b>	114 L	<b>30 gpm</b>
General Dimensions:						
Ground Clearance	889 mm	<b>35"</b>	889 mm	<b>35"</b>	889 mm	<b>35"</b>
Width (with 711 mm/28" Track Shoe)	3327 mm	<b>131"</b>	3327 mm	<b>131"</b>	3327 mm	<b>131"</b>
Adjustable to	3607 mm	<b>142"</b>	3607 mm	<b>142"</b>	3607 mm	<b>142"</b>
Height (to top of cab with standard skylight)	3556 mm	<b>140"</b>	3658 mm	<b>144"</b>	3962 mm	<b>156"</b>
Tail Swing	2743 mm	<b>9'0"</b>	2743 mm	<b>9'0"</b>	2743 mm	<b>9'0"</b>

\*Standard linkage — Lift over front of tracks.

\*\*Long felling linkage — Lift over front of tracks.

These illustrations and values are ESTIMATED for TRUCK SHIPMENT ONLY FROM THE FACTORY.  
These are subject to change based on attachments, configurations, add-ons, etc.

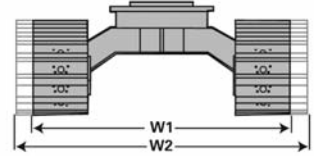

511/521/522/532 Track Feller Bunchers

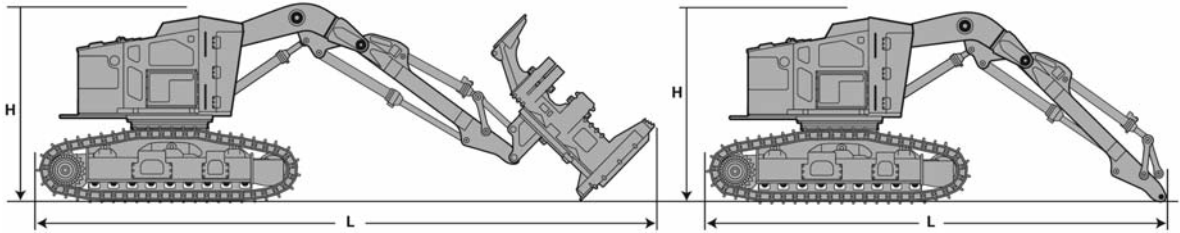

6

ZTS Track Feller Bunchers Shipping Dimensions

MODEL	Length		Height**		Width 1+		Width 2++		Weight	
<b>511</b>	8458 mm	333"	3378 mm	133"	3200 mm	126"	—	—	24 362 kg	53,710 lb
<b>511*</b>	10 744 mm	423"	3378 mm	133"	3200 mm	126"	—	—	27 782 kg	61,210 lb
<b>521</b>	8636 mm	340"	3556 mm	140"	3200 mm	126"	—	—	27 084 kg	59,710 lb
<b>521*</b>	10 947 mm	431"	3556 mm	140"	3200 mm	126"	—	—	30 504 kg	67,250 lb
<b>522</b>	8636 mm	340"	3861 mm	152"	3200 mm	126"	3480 mm	137"	30 410 kg	67,040 lb
<b>522*</b>	10 947 mm	431"	3861 mm	152"	3200 mm	126"	3480 mm	137"	33 830 kg	74,580 lb
<b>532</b>	8611 mm	339"	3962 mm	156"	3200 mm	126"	3480 mm	137"	31 619 kg	69,710 lb
<b>532*</b>	10 922 mm	430"	3962 mm	156"	3200 mm	126"	3480 mm	137"	35 039 kg	77,250 lb

Length, Height and Width assume 610 mm (24") Single Grouser shoes.

\*With HF 201 Partial Tilt Felling Head, tilted back and lifted (assumes an estimated additional head weight of 3420 kg (7540 lb)).

\*\*Height is to top of cab with standard skylight.

+Width 1 is minimum width with 610 mm (24") Single Grouser shoes.

++Width 2 is maximum width when undercarriage is set wide.

These illustrations and values are ESTIMATED for TRUCK SHIPMENT ONLY FROM THE FACTORY. These are subject to change based on attachments, configurations, add-ons, etc.

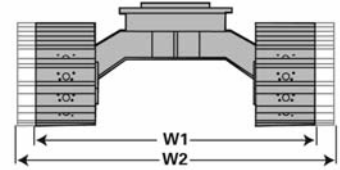

**552 (Tilter) Track Feller Bunchers Standard Linkage**

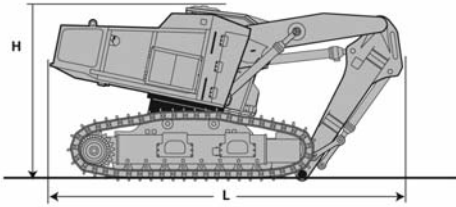

**541/551 (Non-Tilter) 752 (Tilter) Track Feller Bunchers Standard Linkage**

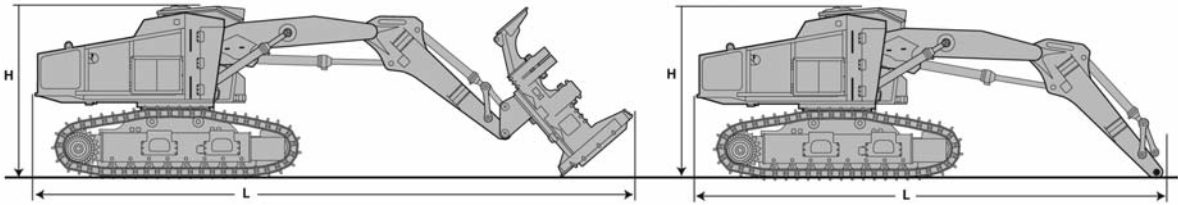

**FTS Track Feller Bunchers Shipping Dimensions**

MODEL	Length		Height**		Width 1+		Width 2++		Weight	
<b>541</b>	9423 mm	<b>371"</b>	3556 mm	<b>140"</b>	3327 mm	<b>131"</b>	3607 mm	<b>142"</b>	30 191 kg	<b>66,560 lb</b>
<b>541*</b>	11 709 mm	<b>461"</b>	3556 mm	<b>140"</b>	3327 mm	<b>131"</b>	3607 mm	<b>142"</b>	33 847 kg	<b>74,621 lb</b>
<b>551</b>	9423 mm	<b>371"</b>	3658 mm	<b>144"</b>	3327 mm	<b>131"</b>	3607 mm	<b>142"</b>	31 057 kg	<b>68,468 lb</b>
<b>551*</b>	11 709 mm	<b>461"</b>	3658 mm	<b>144"</b>	3327 mm	<b>131"</b>	3607 mm	<b>142"</b>	34 713 kg	<b>76,529 lb</b>
<b>552</b>	9423 mm	<b>371"</b>	3962 mm	<b>156"</b>	3327 mm	<b>131"</b>	3607 mm	<b>142"</b>	35 680 kg	<b>78,660 lb</b>
<b>552*</b>	11 709 mm	<b>461"</b>	3962 mm	<b>156"</b>	3327 mm	<b>131"</b>	3607 mm	<b>142"</b>	39 336 kg	<b>86,721 lb</b>

Length, Height and Width assume 711 mm (28") Single Grouser shoes.

\*With HF 221 Partial Tilt Felling Head, tilted back and lifted (assumes an estimated additional head weight of 3656 kg (8061 lb)).

\*\*Height is to top of cab with standard skylight.

+Width 1 is minimum width with 711 mm (28") Single Grouser shoes.

++Width 2 is maximum width when undercarriage is set wide.

These illustrations and values are ESTIMATED for TRUCK SHIPMENT ONLY FROM THE FACTORY. These are subject to change based on attachments, configurations, add-ons, etc.

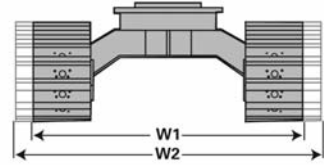

**541/551 (Non-Tilter) 552 (Tilter) Track Feller Bunchers Long Felling Linkage**

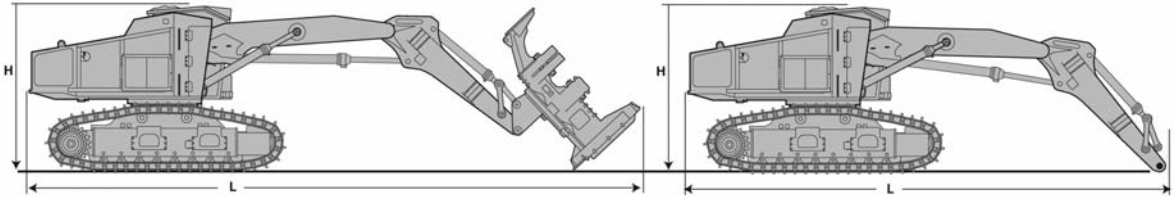

6

**FTS Track Feller Bunchers Shipping Dimensions**

MODEL	Length		Height**		Width 1+		Width 2++		Weight	
<b>541</b>	11 074 mm	<b>436"</b>	3556 mm	<b>140"</b>	3327 mm	<b>131"</b>	3607 mm	<b>142"</b>	30 499 kg	<b>67,239 lb</b>
<b>541*</b>	13 360 mm	<b>526"</b>	3556 mm	<b>140"</b>	3327 mm	<b>131"</b>	3607 mm	<b>142"</b>	34 155 kg	<b>75,300 lb</b>
<b>551</b>	11 074 mm	<b>436"</b>	3658 mm	<b>144"</b>	3327 mm	<b>131"</b>	3607 mm	<b>142"</b>	31 365 kg	<b>69,147 lb</b>
<b>551*</b>	13 360 mm	<b>526"</b>	3658 mm	<b>144"</b>	3327 mm	<b>131"</b>	3607 mm	<b>142"</b>	35 021 kg	<b>77,208 lb</b>
<b>552</b>	11 024 mm	<b>434"</b>	3962 mm	<b>156"</b>	3327 mm	<b>131"</b>	3607 mm	<b>142"</b>	35 988 kg	<b>79,339 lb</b>
<b>552*</b>	13 310 mm	<b>524"</b>	3962 mm	<b>156"</b>	3327 mm	<b>131"</b>	3607 mm	<b>142"</b>	39 644 kg	<b>87,400 lb</b>

Length, Height and Width assume 711 mm (28") Single Grouser shoes.

\*With HF 221 Partial Tilt Felling Head, tilted back and lifted (assumes an estimated additional head weight of 3656 kg (8061 lb)).

\*\*Height is to top of cab with standard skylight.

+Width 1 is minimum width with 711 mm (28") Single Grouser shoes.

++Width 2 is maximum width when undercarriage is set wide.



**Lift Range Information — Felling Linkage  
511/521/522/532 — ZTS**

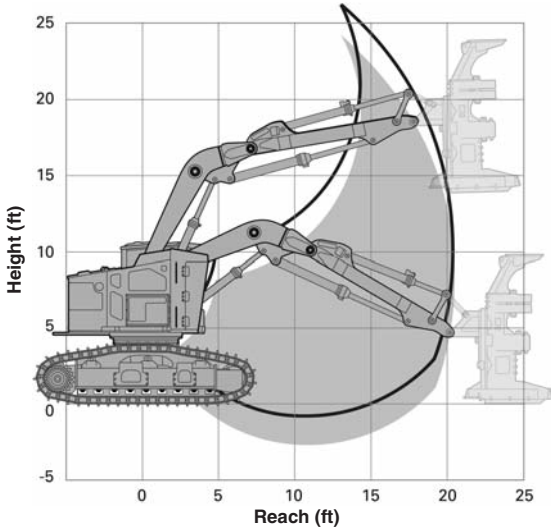

NOTE: \_\_\_\_ Line represents Tilter Model.

**Lift Over Front of Tracks**

MODEL	511		521		522		532	
Reach	Lift Capacity		Lift Capacity		Lift Capacity		Lift Capacity	
2.4 m (8'0")	16 900 kg	<b>37,200 lb</b>	17 300 kg	<b>38,200 lb</b>	17 800 kg	<b>39,300 lb</b>	17 900 kg	<b>39,400 lb</b>
4.5 m (15'0")	9500 kg	<b>21,000 lb</b>	9600 kg	<b>21,200 lb</b>	9700 kg	<b>21,500 lb</b>	9800 kg	<b>21,500 lb</b>
6.1 m (20'0")	7100 kg	<b>15,600 lb</b>	7100 kg	<b>15,600 lb</b>	7100 kg	<b>15,600 lb</b>	7100 kg	<b>15,600 lb</b>

**Lift Over Side of Tracks**

MODEL	511		521		522		532	
Reach	Lift Capacity		Lift Capacity		Lift Capacity		Lift Capacity	
2.4 m (8'0")	16 900 kg	<b>37,200 lb</b>	17 300 kg	<b>38,200 lb</b>	17 800 kg	<b>39,300 lb</b>	17 900 kg	<b>39,400 lb</b>
4.5 m (15'0")	8600 kg	<b>18,900 lb</b>	9500 kg	<b>21,000 lb</b>	9700 kg	<b>21,500 lb</b>	9800 kg	<b>21,500 lb</b>
6.1 m (20'0")	5400 kg	<b>11,900 lb</b>	6100 kg	<b>13,300 lb</b>	7100 kg	<b>15,600 lb</b>	7100 kg	<b>15,600 lb</b>

NOTE: Lift Capacity shown without attachment.  
Additional reach and attachment weight will reduce lift capacity.

**Lift Range Information —  
Standard Felling Linkage  
541/551/552 — FTS**

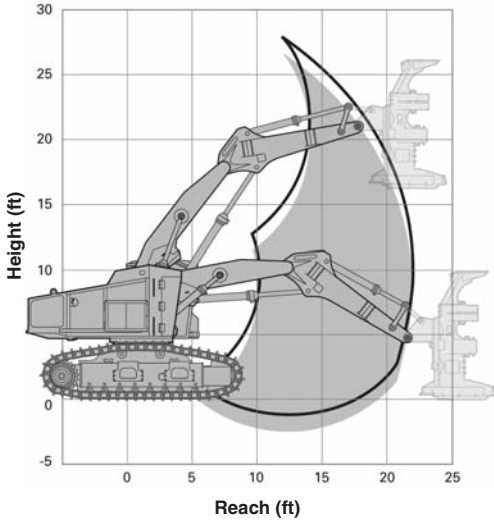

**Lift Range Information —  
Long Felling Linkage  
541/551/552 — FTS**

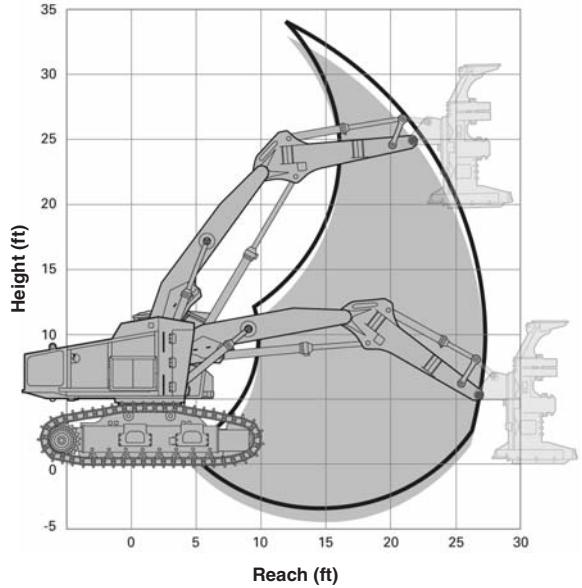

NOTE: \_\_\_\_ Line represents Tilter Model.

**Lift Over Front of Tracks**

MODEL	541		551		552	
<b>Reach Linkage</b>	<b>Lift Capacity Standard Felling</b>		<b>Lift Capacity Standard Felling</b>		<b>Lift Capacity Standard Felling</b>	
3.2 m (10'6")	21 600 kg	47,700 lb	21 800 kg	48,000 lb	22 200 kg	49,000 lb
4.5 m (15'0")	15 200 kg	33,500 lb	15 300 kg	33,700 lb	15 500 kg	34,200 lb
6.6 m (21'6")	9400 kg	21,800 lb	9400 kg	21,800 lb	9400 kg	21,800 lb
<b>Reach Linkage</b>	<b>Lift Capacity Long Felling</b>		<b>Lift Capacity Long Felling</b>		<b>Lift Capacity Long Felling</b>	
3.0 m (10'0")	20 800 kg	45,900 lb	21 000 kg	46,400 lb	21 800 kg	48,000 lb
6.1 m (20'0")	10 400 kg	22,900 lb	10 700 kg	23,500 lb	10 900 kg	23,900 lb
8.2 m (27'0")	6400 kg	14,200 lb	7400 kg	16,300 lb	7700 kg	16,900 lb

**Lift Over Side of Tracks**

MODEL	541		551		552	
<b>Reach Linkage</b>	<b>Lift Capacity Standard Felling</b>		<b>Lift Capacity Standard Felling</b>		<b>Lift Capacity Standard Felling</b>	
3.2 m (10'6")	19 400 kg	42,800 lb	21 800 kg	48,000 lb	22 200 kg	49,000 lb
4.5 m (15'0")	10 600 kg	23,400 lb	13 200 kg	29,100 lb	14 900 kg	32,900 lb
6.6 m (21'6")	6100 kg	13,500 lb	7600 kg	16,700 lb	8600 kg	19,000 lb
<b>Reach Linkage</b>	<b>Lift Capacity Long Felling</b>		<b>Lift Capacity Long Felling</b>		<b>Lift Capacity Long Felling</b>	
3.0 m (10'0")	20 800 kg	45,900 lb	21 000 kg	46,400 lb	21 800 kg	48,000 lb
6.1 m (20'0")	6600 kg	14,600 lb	8200 kg	18,100 lb	9300 kg	20,600 lb
8.2 m (27'0")	4100 kg	9100 lb	5200 kg	11,400 lb	6000 kg	13,100 lb

NOTE: Lift Capacity shown without attachment.  
Additional reach and attachment weight will reduce lift capacity.

**553/563/573 Wheel Feller Buncher Features:**

- **Field proven Cat C6.6 (553) and Cat C7 (563/573) ACERT engines** provide power and reliability.
- **Long-life center joint**, and 90 degree steering articulation to maximize thinning productivity.
- **Standard with quarter-turn steering with adjustable tilt-telescoping steering column;** available with joystick steering as an option.
- **Saw attachments** are power and performance-matched to tractors.
- **Industry leading visibility with three-piece windshield and skylight** provides an unobstructed viewing of the tree bases and tops throughout full articulation.

<b>MODEL</b>	<b>553</b>		<b>563</b>		<b>573</b>	
Gross Power	129 kW	<b>173 hp</b>	147 kW	<b>197 hp</b>	168 kW	<b>225 hp</b>
Operating Weight (without attachment)	11 476 kg	<b>25,300 lb</b>	12 372 kg	<b>27,275 lb</b>	12 599 kg	<b>27,775 lb</b>
Engine Model	<b>C6.6 ACERT</b>		<b>C7 ACERT</b>		<b>C7 ACERT</b>	
Travel Speed (Low Range with 28L × 26 tires)	8 km/h	<b>0-5 mph</b>	8 km/h	<b>0-5 mph</b>	8 km/h	<b>0-5 mph</b>
Travel Speed (High Range with 28L × 26 tires)	24 km/h	<b>0-15 mph</b>	24 km/h	<b>0-15 mph</b>	24 km/h	<b>0-15 mph</b>
Disc Saw (Fixed displacement piston pump)	98 L/min @ 24 132 kPa	<b>26 gpm @ 3500 psi</b>	114 L/min @ 27 579 kPa	<b>30 gpm @ 4000 psi</b>	129 L/min @ 27 579 kPa	<b>34 gpm @ 4000 psi</b>
Fuel Capacity	273 L	<b>72 U.S. gal</b>	273 L	<b>72 U.S. gal</b>	273 L	<b>72 U.S. gal</b>
General Dimensions:						
Ground Clearance	53 cm	<b>21"</b>	53 cm	<b>21"</b>	53 cm	<b>21"</b>
Articulation Angle		<b>84°</b>		<b>90°</b>		<b>90°</b>
Wheelbase	258 cm	<b>101.5"</b>	287 cm	<b>113"</b>	287 cm	<b>113"</b>
Width (standard gauge wheels)	274 cm	<b>107.9"</b>	292 cm	<b>115.1"</b>	292 cm	<b>115.1"</b>
Turning Radius (standard gauge wheels)	455 cm	<b>14'11"</b>	503 cm	<b>16'6"</b>	503 cm	<b>16'6"</b>
Height	316 cm	<b>10'4"</b>	320 cm	<b>10'6"</b>	320 cm	<b>10'6"</b>
Length (with SH-50 High Capacity Saw)	679 cm	<b>22'3"</b>	730 cm	<b>23'11"</b>		<b>—</b>
Length (with SH-56 Side Cut Saw)		<b>—</b>	768 cm	<b>25'2"</b>	768 cm	<b>25'2"</b>

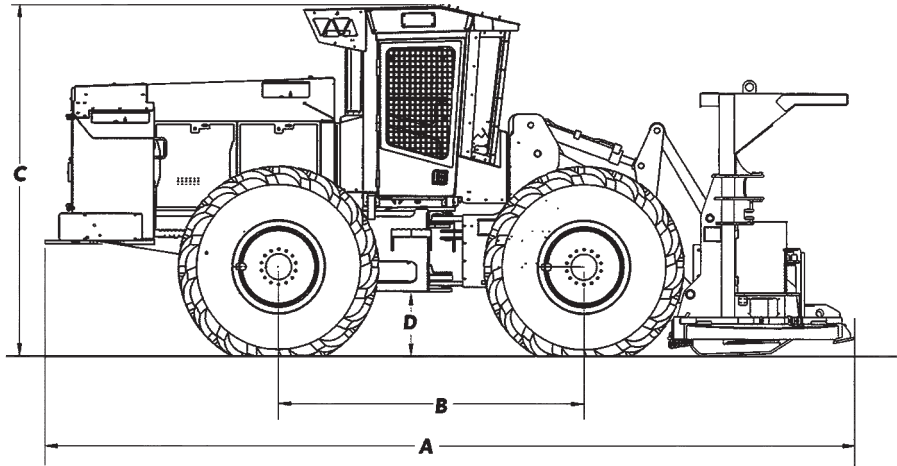

MODEL	553		563		573	
<b>A</b> Overall Length†	679 cm	267.3"	767 cm	302"	767 cm	302"
<b>B</b> Wheelbase	258 cm	101.5"	287 cm	113"	287 cm	113"
<b>C</b> Overall Height*	316 cm	124.3"	320 cm	126"	320 cm	126"
<b>D</b> Ground Clearance**	53 cm	21"	53 cm	21"	53 cm	21"
<b>E</b> Overall Width***	274 cm	107.9"	292 cm	115.1"	292 cm	115.1"
<b>F</b> Turning Radius	455 cm	179"	503 cm	198"	503 cm	198"
<b>G</b> Weight, less Attachment	11 476 kg	25,300 lb	12 372 kg	27,275 lb	12 599 kg	27,775 lb

All dimensions shown with 28L × 26 tires.

†553 with SH-50 High Capacity Saw, 563/573 with SS-56 Side Cut Saw.

\*For 67 × 34 × 26 tires add 3 cm (1.2"); for 30.5 × 32 tires add 13 cm (5").

\*\*For 67 × 34 × 26 tires add 3 cm (1.2"); for 30.5 × 32 tires add 10 cm (4").

\*\*\*For 67 × 34 × 26 tires add 3 cm (1.2"); for 30.5 × 32 tires add 12 cm (4.8").

**Sustainability:**

- **Major structures and components** are built to be rebuilt, reducing waste and replacement costs.
- **ACERT Technology** reduces engine emissions at point of combustion with less moving parts for lower operating costs.

**Wheel Harvester Features:**

- **Cat C7 engine with ACERT Technology**, field-proven and U.S. EPA Tier 3 compliant.
- **Standard “auto-seek” processing head computer** cuts at operator-specified length.
- **Two-cylinder tilt mechanism** allows for leveling in uneven terrain

- **Telescoping “V” Bottom (5-sided) harvester boom**; 8.23 m (27'0") reach to tree.
- **Spacious cab** with high visibility over entire work area; IQAN MDL control system and full function graphic display.
- **Heavy-duty boom mount base.**
- **Electric refill pump.**
- **Electric refill pump** for hydraulic oil.
- **Heavy-duty center oscillation bearing** with 15° oscillation each way.
- **Front frame** contains NAF Gear Drive Bogie, differential lock and wet disc brakes.

<b>MODEL</b>	<b>550</b>	
Gross Power	147 kW	<b>197 hp</b>
Operating Weight (with attachment)	21 319 kg	<b>47,040 lb</b>
Engine Model	<b>C7 ACERT</b>	
Rated RPM	<b>1800</b>	
Boom Length	8.2-10.1 m	<b>27'0"-33'0"</b>
Fuel Capacity	454 L	<b>120 U.S. gal</b>
Variable Displacement Implement Pump	<b>140 cc</b>	
Hydraulic Tank (with filtering of all return oil)	378.4 L	<b>100 U.S. gal</b>

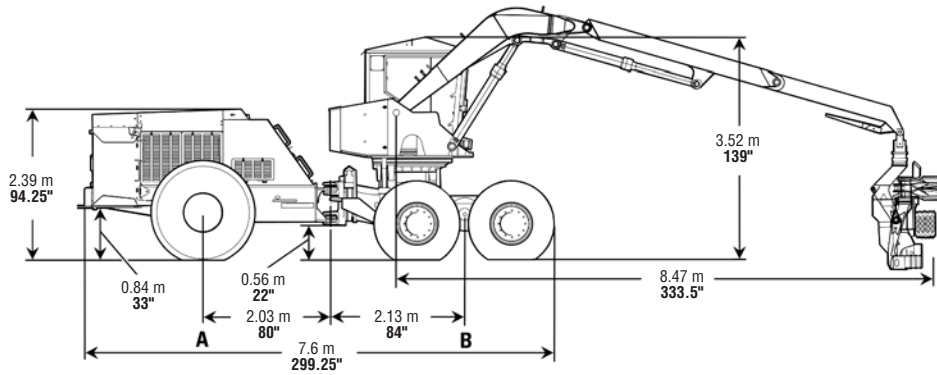
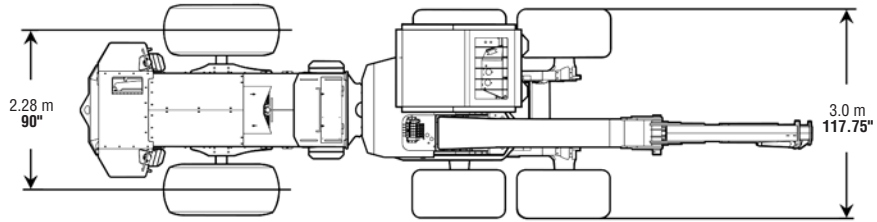

6

**MODEL**

**550**

Weight with Prentice PD-46 Head @ 3 m (10'0") Radius:  
 Point A (Rear Axle)  
 Point B (Front Axle)  
 Total: with PD-46 Head Installed

6858 kg	15,120 lb
14 479 kg	31,920 lb
21 319 kg	47,040 lb

**Track Feller Buncher Heads (Available with Partial Lateral and Full Lateral Tilt)**

<b>MODEL</b>	<b>HF 201</b>		<b>HF 221</b>	
Accumulation Area	0.46 m <sup>2</sup>	<b>5.0 ft<sup>2</sup></b>	0.51 m <sup>2</sup>	<b>5.5 ft<sup>2</sup></b>
Maximum Cut	572 mm	<b>22.5"</b>	620 mm	<b>24.4"</b>
Width	1690 mm	<b>66.5"</b>	1800 mm	<b>70.9"</b>
Height	2815 mm	<b>110.8"</b>	3022 mm	<b>119"</b>
Weight (PLT)	3420 kg	<b>7540 lb</b>	3656 kg	<b>8061 lb</b>
Weight (FLT)	3874 kg	<b>8540 lb</b>	4111 kg	<b>9062 lb</b>

**Wheel Feller Buncher Heads**

<b>MODEL</b>	<b>SH-50</b>		<b>SH-56</b>		<b>SS-56</b>	
Accumulation Area	0.58 m <sup>2</sup>	<b>6.2 ft<sup>2</sup></b>	0.65 m <sup>2</sup>	<b>7.0 ft<sup>2</sup></b>	0.37 m <sup>2</sup>	<b>4.0 ft<sup>2</sup></b>
Maximum Single Cut	508 mm	<b>20"</b>	560 mm	<b>22"</b>	560 mm	<b>22"</b>
Directional Felling Capacity	<b>N/A</b>		<b>N/A</b>		762 mm	<b>30"</b>
Width	1760 mm	<b>69.25"</b>	1613 mm	<b>63.5"</b>	1727 mm	<b>68.0"</b>
Height	2642 mm	<b>104"</b>	2667 mm	<b>105"</b>	2413 mm	<b>95"</b>
Weight	2650 kg	<b>5850 lb</b>	2812 kg	<b>6200 lb</b>	2821 kg	<b>6220 lb</b>

<b>MODEL</b>	<b>RH-54</b>		<b>SC-57</b>	
Accumulation Area	0.58 m <sup>2</sup>	<b>6.25 ft<sup>2</sup></b>	0.47 m <sup>2</sup>	<b>5.1 ft<sup>2</sup></b>
Maximum Single Cut	533 mm	<b>21"</b>	570 mm	<b>22.4"</b>
Directional Felling Capacity	<b>N/A</b>		<b>N/A</b>	
Width	1930 mm	<b>76.0"</b>	1615 mm	<b>63.6"</b>
Height	2413 mm	<b>95"</b>	3023 mm	<b>119"</b>
Weight	2585 kg	<b>5700 lb</b>	3003 kg	<b>6620 lb</b>

**525C/535C/545C Features:****MORE Comfort ... Operator Station**

- Ergonomic improvements like relocation of the dozer control and governor pedal will improve operator comfort and reduce operator fatigue.
- New display cluster, similar to the Cat T Series Track-Type Tractors, allows for easy monitoring of machine operation.

**MORE Uptime ... Serviceability/Reliability**

- Redesign of engine enclosures allows for easier and faster daily maintenance.
- New environmentally friendly ecology drains on all fluid compartments make changing the fluid easier, reducing down time.
- ToughGuard™ abrasion resistant hoses inside the grapple, arch, boom and across the hitch are more durable allowing them to last longer.
- Hoses located across the hitch area are easier to access reducing maintenance time.
- Caterpillar designed and manufactured structures combined with existing proven power train components maximize performance.

**MORE Profit ... New Cat C7 ACERT engine**

- New Cat C7 ACERT engine meets EPA Tier 3 emissions regulations and uses a proven system that has been tested and validated.
- C7 ACERT engine delivers proven fuel efficiency, lowering owning and operating costs.

**New Cat Grapples**

- Wear resistant cast tips and tong redesign allows for increased loading performance and maximum log retention, increasing grapple productivity.
- Dual function arch and cable skidder options available to meet various logging requirements (525C/535C/545C).
- Single function arch and cable skidder options available to meet various logging requirements (525C models only).

**Lock-up torque converter clutch**, an industry exclusive on Cat Wheel Skidders, provides operating speed increases with improved power and fuel efficiencies.

**Locking differentials** — Selectable from the cab to improve traction and control wheel slippage.



<b>MODEL</b>	<b>525C</b>		<b>535C</b>		<b>545C</b>	
Net Flywheel Power	136 kW	<b>182 hp</b>	152 kW	<b>204 hp</b>	163 kW	<b>219 hp</b>
Gross Power — SAE J1995	146 kW	<b>196 hp</b>	162 kW	<b>218 hp</b>	173 kW	<b>232 hp</b>
Operating Weight	17 711 kg	<b>39,045 lb</b>	18 044 kg	<b>39,780 lb</b>	19 198 kg	<b>42,325 lb</b>
Engine Model	<b>C7 ACERT</b>		<b>C7 ACERT</b>		<b>C7 ACERT</b>	
Rated Engine RPM	<b>1800</b>		<b>1800</b>		<b>1800</b>	
Bore	110 mm	<b>4.33"</b>	110 mm	<b>4.33"</b>	127 mm	<b>5"</b>
Stroke	127 mm	<b>5"</b>	127 mm	<b>5"</b>	127 mm	<b>5"</b>
Displacement	7.2 L	<b>439 in<sup>3</sup></b>	7.2 L	<b>439 in<sup>3</sup></b>	7.2 L	<b>439 in<sup>3</sup></b>
No. of Cylinders	<b>6</b>		<b>6</b>		<b>6</b>	
Speeds Forward:						
1st	6.4 km/h	<b>4.0 mph</b>	6.4 km/h	<b>4.0 mph</b>	6.4 km/h	<b>4.0 mph</b>
2nd	9.0 km/h	<b>5.6 mph</b>	9.0 km/h	<b>5.6 mph</b>	9.0 km/h	<b>5.6 mph</b>
3rd	10.9 km/h	<b>6.8 mph</b>	10.9 km/h	<b>6.8 mph</b>	10.9 km/h	<b>6.8 mph</b>
4th	15.3 km/h	<b>9.5 mph</b>	15.3 km/h	<b>9.5 mph</b>	15.3 km/h	<b>9.5 mph</b>
5th	27.5 km/h	<b>17.1 mph</b>	27.5 km/h	<b>17.1 mph</b>	27.5 km/h	<b>17.1 mph</b>
Speeds Reverse:						
1st	6.2 km/h	<b>3.9 mph</b>	6.2 km/h	<b>3.9 mph</b>	6.2 km/h	<b>3.9 mph</b>
2nd	10.5 km/h	<b>6.5 mph</b>	10.5 km/h	<b>6.5 mph</b>	10.5 km/h	<b>6.5 mph</b>
3rd	18.6 km/h	<b>11.6 mph</b>	18.6 km/h	<b>11.6 mph</b>	18.6 km/h	<b>11.6 mph</b>
Maximum Drawbar Pull (based on 6% rolling resistance)		<b>37,500 lb</b>		<b>40,200 lb</b>		<b>41,900 lb</b>
Turning Radius (over 30.5 × 32 tires)	6000 mm	<b>236.2"</b>	6000 mm	<b>236.2"</b>	6400 mm	<b>252"</b>
Capacity:						
Fuel Tank	315 L	<b>83.2 U.S. gal</b>	315 L	<b>83.2 U.S. gal</b>	378 L	<b>99.8 U.S. gal</b>
Cooling System	56.7 L	<b>15 U.S. gal</b>	56.7 L	<b>15 U.S. gal</b>	56.7 L	<b>15 U.S. gal</b>
Hydraulic System — Tank	54 L	<b>14.3 U.S. gal</b>	54 L	<b>14.3 U.S. gal</b>	54 L	<b>14.3 U.S. gal</b>
Hydraulic System — Total	112 L	<b>29.6 U.S. gal</b>	112 L	<b>29.6 U.S. gal</b>	112 L	<b>29.6 U.S. gal</b>
General Dimensions:						
Wheelbase	3534 mm	<b>139.2"</b>	3534 mm	<b>139.2"</b>	3939 mm	<b>155.1"</b>
Width	3398 mm	<b>133.8"</b>	3398 mm	<b>133.8"</b>	3398 mm	<b>133.8"</b>
Height to Top of Cab*	3184 mm	<b>125.4"</b>	3184 mm	<b>125.4"</b>	3184 mm	<b>125.4"</b>
Ground Clearance	581 mm	<b>22.9"</b>	533 mm	<b>22.9"</b>	533 mm	<b>22.9"</b>

\*Add 188 mm (7.4") if equipped with optional lights or water tank.

<b>WINCH MODEL</b>	<b>525C — Grapple</b>		<b>525C — Cable</b>		<b>535C — Grapple</b>	
Maximum Line Pull — Bare Drum	175 kN	<b>39,342 lb</b>	183.5 kN	<b>41,270 lb</b>	175 kN	<b>39,342 lb</b>
Maximum Line Speed	40.2 m/min	<b>132 fpm</b>	110 m/min	<b>360 fpm</b>	40.2 m/min	<b>132 fpm</b>
Drum Capacity:						
19.0 mm (¾")	47 m	<b>154'0"</b>	45 m	<b>148'0"</b>	47 m	<b>154'0"</b>
22.2 mm (⅞")	30 m	<b>97'0"</b>	32 m	<b>105'0"</b>	30 m	<b>97'0"</b>
25.4 mm (1")	28 m	<b>91'0"</b>	25 m	<b>82'0"</b>	28 m	<b>91'0"</b>
Drum Diameter	229 mm	<b>9"</b>	254 mm	<b>10"</b>	229 mm	<b>9"</b>
Drum Width	279 mm	<b>11"</b>	279 mm	<b>11"</b>	279 mm	<b>11"</b>
<b>WINCH MODEL</b>	<b>535C — Cable</b>		<b>545C — Grapple</b>		<b>545C — Cable</b>	
Maximum Line Pull — Bare Drum	197.5 kN	<b>44,400 lb</b>	175 kN	<b>39,342 lb</b>	204 kN	<b>45,850 lb</b>
Maximum Line Speed	110 m/min	<b>360 fpm</b>	40.2 m/min	<b>132 fpm</b>	110 m/min	<b>360 fpm</b>
Drum Capacity:						
19.0 mm (¾")	45 m	<b>148'0"</b>	47 m	<b>154'0"</b>	45 m	<b>148'0"</b>
22.2 mm (⅞")	32 m	<b>105'0"</b>	30 m	<b>97'0"</b>	32 m	<b>105'0"</b>
25.4 mm (1")	25 m	<b>82'0"</b>	28 m	<b>91'0"</b>	25 m	<b>82'0"</b>
Drum Diameter	254 mm	<b>10"</b>	229 mm	<b>9"</b>	254 mm	<b>10"</b>
Drum Width	279 mm	<b>11"</b>	279 mm	<b>11"</b>	279 mm	<b>11"</b>

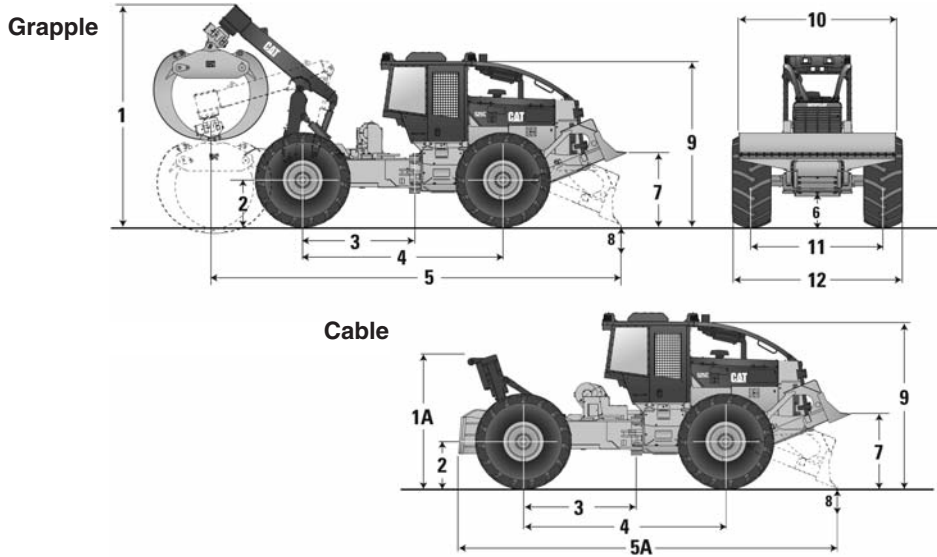

MODEL	525C		535C		545C	
<b>1</b> Ground Level to Top of Boom (Grapple)	—		—		4302 mm	169.4"
Dual Function	4103 mm	161.5"	—		—	
Single Function	3760 mm	148"	—		—	
Standard Boom	—		4103 mm	161.5"	—	
Extended Boom	—		4303 mm	169.4"	—	
<b>1A</b> Ground Level to Top Roller (Cable)	2794 mm	110"	2794 mm	110"	2771 mm	109"
<b>2</b> Ground Level to Axle Center Line (with 30.5 × 32 tires)	843 mm	33.2"	843 mm	33.2"	843 mm	33.2"
<b>3</b> Rear Axle Center Line to Pin	1798 mm	70.8"	1798 mm	70.8"	2203 mm	86.7"
<b>4</b> Wheelbase	3534 mm	139.2"	3534 mm	139.2"	3939 mm	155.1"
<b>5</b> Overall Length (Grapple)	—		—		8028 mm	316"
Dual Function	7626 mm	300.2"	—		—	
Single Function	8369 mm	329.4"	—		—	
Standard Boom	—		7626 mm	300.2"	—	
Extended Boom	—		7514 mm	295.8"	—	
<b>5A</b> Overall Length (Cable)	6945 mm	273.4"	6945 mm	273.4"	7514 mm	295.8"
<b>6</b> Ground Clearance	581 mm	22.9"	533 mm	22.9"	533 mm	22.9"
<b>7</b> Decking Blade Lift Height	1381 mm	54.4"	1381 mm	54.4"	1381 mm	54.4"
<b>8</b> Decking Blade Dig Depth	456 mm	17.9"	456 mm	17.9"	456 mm	17.9"
<b>9</b> Height to Top of Cab*	3184 mm	125.4"	3184 mm	125.4"	3184 mm	125.4"
<b>10</b> Decking Blade Width	3138 mm	123.5"	3138 mm	123.5"	3138 mm	123.5"
<b>11</b> Tread Width	2622 mm	103.2"	2622 mm	103.2"	2622 mm	103.2"
<b>12</b> Overall Width	3398 mm	133.8"	3398 mm	133.8"	3398 mm	133.8"

\*Add 188 mm (7.4") if equipped with optional lights or water tank.

**Single-function arch**

- Versatile attachment suitable for selection or clear cut applications. Reach consists of one vertical arc and typical application is short cycles and/or larger diameter timber.

**Sorting grapple** is designed to pick up individual or several stems for quick cycles of 305 mm (12") or larger diameter trees.

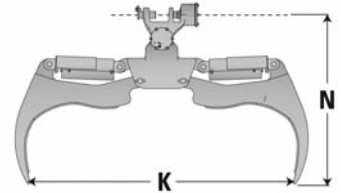
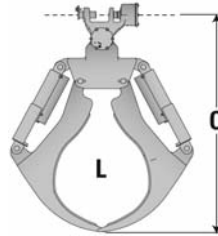
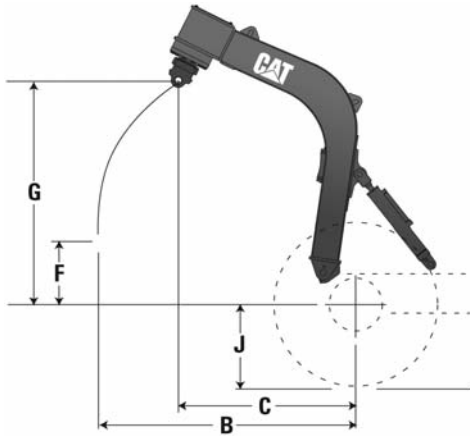

**360° Sorting Grapple for 525C**

		A	B	C	D	E	F	G	H	J	K	M	N	O	P	L
2.54 m (100")	mm		2521	1630			600	2212		843	2540		1590	2045		0.83 m <sup>2</sup>
Sorting	in		99.3	64.2			23.6	87.1		33.2	100		62.6	80.5		9 ft <sup>2</sup>

**Standard Grapple**

- Normal skidding
- Multipurpose applications
- Includes final harvest
- Heavier Wood
  - larger diameter stems
  - tall timber
  - high density wood

**Thinning Special Grapple\***

- Special skidding
- Thinning or lighter stems
- Does not include final harvest
- Lighter individual stems
  - smaller diameter stems
  - shorter timber
  - lower density wood
- For large number of smaller stems/load

\*Large stems can be skidded, but the grapple will not appear full and must not be filled to area capacity. See recommended load ranges for wheel skidders.

**Determine proper grapple selection based on:**

Log Size: Diameter, Length, Density, Load Weight

Site Conditions: Slope, Ground Conditions, Traction

**RECOMMENDED LOAD RANGES FOR  
C SERIES WHEEL SKIDDERS**

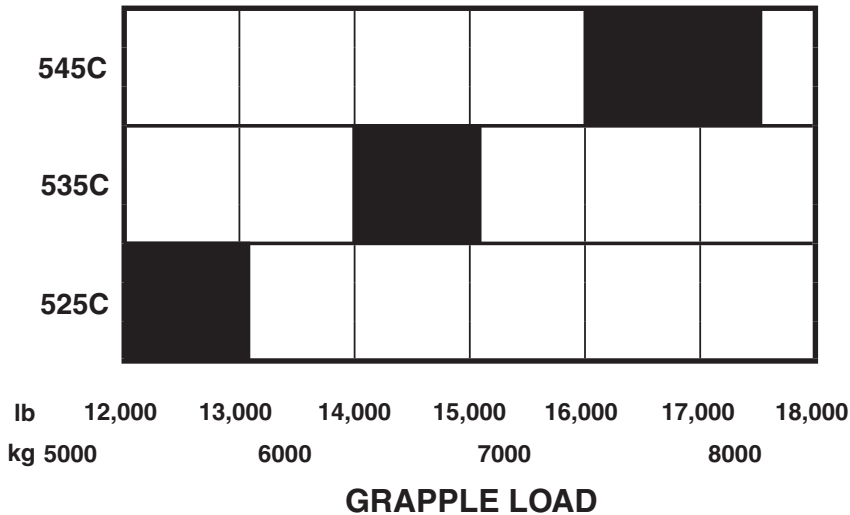

Performance on steeper grades limits recommended capacity capability for good performance, so select the next larger machine for tougher site conditions or skid less load per drag to keep speed up and maximize productivity.

**New Cat Continuous Rotate (CCR) Grapple**

CCR Grapples for Cat 545C, 535C and 525C Wheel Skidders are sourced out of LaGrange, GA for factory installation.

The CCR Grapple has an indexator rotator SR21 with high bearing capacity and improved motor torque. Caterpillar pins are used in the snubber, head and grapples frame. The following contains information on the available models, which are presented here to suggest a range of grapple possibilities.

**Single Function Frame Group**

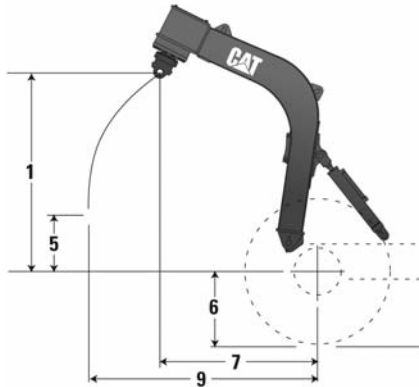

**Dual Function Frame Group**

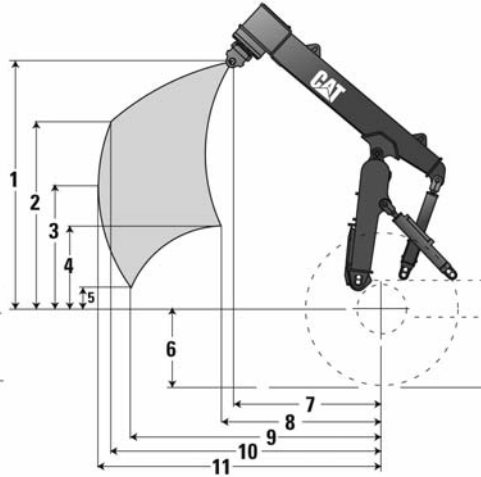

MODEL	525C		535C		545C					
	Single Function	Dual Function	Standard Boom	Extended Boom	Continuous Rotation					
<b>1</b> Lift highest, retracted	2212 mm	87.1"	2623 mm	103.3"	2847 mm	112.1"	2817 mm	111"		
<b>2</b> Lift highest, farthest	—	1944 mm	76.5"	1944 mm	76.5"	2192 mm	86.3"	2163 mm	85"	
<b>3</b> Lift maximum reach	—	1336 mm	52.6"	1336 mm	52.6"	1336 mm	52.6"	1443 mm	57"	
<b>4</b> Lift lowest, retracted	—	752 mm	29.6"	752 mm	29.6"	764 mm	30.1"	1014 mm	40"	
<b>5</b> Lift lowest, farthest	600 mm	23.6"	259 mm	10.2"	259 mm	10.2"	286 mm	11.3"	335 mm	13"
<b>6</b> Loaded tire radius (with 30.5 × 32 tires)	843 mm	33.2"	843 mm	33.2"	843 mm	33.2"	843 mm	33.2"	843 mm	33"
<b>7</b> Reach highest, retracted	1630 mm	64.2"	1513 mm	59.6"	1513 mm	59.6"	1546 mm	60.9"	1653 mm	65"
<b>8</b> Reach lowest, retracted	—	1469 mm	57.8"	1469 mm	57.8"	1666 mm	65.6"	1775 mm	70"	
<b>9</b> Reach lowest, farthest	2521 mm	99.3"	2488 mm	98.0"	2488 mm	98.0"	2706 mm	106.5"	2762 mm	109"
<b>10</b> Reach highest, farthest	—	2765 mm	108.9"	2765 mm	108.9"	2825 mm	111.2"	2978 mm	117"	
<b>11</b> Reach maximum	—	2880 mm	113.4"	2880 mm	113.4"	3037 mm	119.6"	3121 mm	123"	

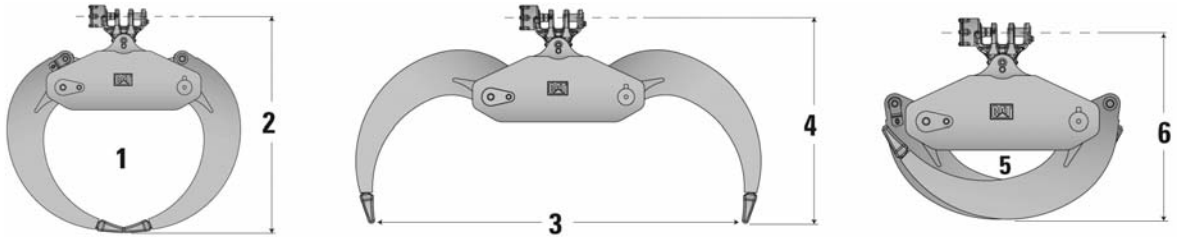

**Continuous Rotate  
 Grapples for 525C**

	1	2	3	4	5	6
1.16 m <sup>2</sup> (12.5 ft <sup>2</sup> ) Bunching	1.16 m <sup>2</sup> 12.5 ft <sup>2</sup>	1920 mm 75.6"	3050 mm 120"	1677 mm 66"	155 mm 6"	1285 mm 50.6"
1.34 m <sup>2</sup> (14.4 ft <sup>2</sup> ) Thinning*	1.34 m <sup>2</sup> 14.4 ft <sup>2</sup>	1981 mm 78"	3124 mm 123"	1832 mm 72.1"	190 mm 7.5"	1371 mm 54"

**Continuous Rotate  
 Grapples for 535C**

	1	2	3	4	5	6
1.34 m <sup>2</sup> (14.4 ft <sup>2</sup> ) Bunching	1.34 m <sup>2</sup> 14.4 ft <sup>2</sup>	1981 mm 78"	3124 mm 123"	1832 mm 72.1"	190 mm 7.5"	1371 mm 54"
1.54 m <sup>2</sup> (16.6 ft <sup>2</sup> ) Thinning*	1.54 m <sup>2</sup> 16.6 ft <sup>2</sup>	2108 mm 83"	3226 mm 127"	1905 mm 75"	183 mm 7.2"	1371 mm 54"

**Continuous Rotate  
 Grapples for 545C**

	1	2	3	4	5	6
1.54 m <sup>2</sup> (16.6 ft <sup>2</sup> ) Bunching	1.54 m <sup>2</sup> 16.6 ft <sup>2</sup>	2108 mm 83"	3226 mm 127"	1905 mm 75"	183 mm 7.2"	1371 mm 54"
1.78 m <sup>2</sup> (19 ft <sup>2</sup> ) Thinning*	1.78 m <sup>2</sup> 19 ft <sup>2</sup>	2159 mm 85"	3429 mm 135"	1880 mm 74"	241 mm 9.5"	1473 mm 58"

\*Thinning Grapple is intended only for use in thinning applications.

**KEY**

- 1 — Grapple capacity
- 2 — Tip to tip height
- 3 — Tong opening
- 4 — Full open height
- 5 — Minimum stem diameter
- 6 — Fully closed height

**Features 527:**

- **Field proven Cat 3304 diesel engine** sets the industry standard for reliability and durability, delivering high horsepower for more drawbar pull, improved skidding performance and ease of operation.
- **Large, heavy duty torque converter**, reduces the tendency for track-to-ground slip, reduces the need for up and downshifting and protects power train components contributing to longer component life.
- **3 speed planetary powershift transmission** works best in high-pull applications and is well suited for large load and steep terrain skidding.
- **Heavy-duty track roller frame** extended to the rear significantly improves traction capability under heavy loads and uphill skidding applications.
- **Wide gauge and long track roller frames** provide outstanding sidehill stability.
- **Improved flotation** — More track on the ground distributes tractor weight and propulsion forces over a much larger area than conventional track skidders. This improves flotation capabilities, gradeability and significantly reduces soil impact.
- **Load sensing hydraulic system** — Variable displacement pressure compensating hydraulic system provides reduced power requirements when there is not hydraulic demand, significantly reduced heat generation, and improving fuel efficiency.
- **Auto-grab feature** — provides constant grapple tong pressure without continuous hydraulic pump demand.
- **Superior component durability** — Final drives are raised above the work area, isolating the power train from ground impact shock and abrasive materials.
- **Excellent ground clearance** — no diagonal braces allow the skidder to pass over stumps and debris, reduces maneuvering for reduced cycle times and minimizes soil impact.
- **Smooth belly pans** — Less likely to hang up in mud and debris in soft ground or swamp logging applications.
- **Easy and comfortable operating environment** — ROPS/FOPS cab allows excellent front and rear viewing, and is pressurized for sound level reduction. The seat is angled and controls are easily reached to reduce operator fatigue and increase productivity.
- **Single lever** grapple control and blade control.
- **Less service time** — Major components are made as modules and most can be removed without removing others, and ground-level access provides convenient servicing to most filters and lube points.
- **Cable and Swing Boom** configurations provide the versatility needed to match the skidder to a wide variety of skidding applications.

MODEL	527 Cable		527 Grapple	
Net Flywheel Power	112 kW	<b>150 hp</b>	112 kW	<b>150 hp</b>
Operating Weight*	18 720 kg	<b>41,270 lb</b>	21 900 kg	<b>48,281 lb</b>
Engine Model	<b>3304 DIT</b>		<b>3304 DIT</b>	
Rated Engine RPM	<b>2200</b>		<b>2200</b>	
Bore	120.65 mm	<b>4.75"</b>	120.65 mm	<b>4.75"</b>
Stroke	152.4 mm	<b>6"</b>	152.4 mm	<b>6"</b>
Displacement	7 L	<b>425 in<sup>3</sup></b>	7 L	<b>425 in<sup>3</sup></b>
No. of Cylinders	<b>4</b>		<b>4</b>	
Speeds Forward:				
1st	3.7 km/h	<b>2.3 mph</b>	3.7 km/h	<b>2.3 mph</b>
2nd	6.6 km/h	<b>4.1 mph</b>	6.6 km/h	<b>4.1 mph</b>
3rd	11.5 km/h	<b>7.1 mph</b>	11.5 km/h	<b>7.1 mph</b>
Speeds Reverse:				
1st	4.6 km/h	<b>2.8 mph</b>	4.6 km/h	<b>2.8 mph</b>
2nd	8.3 km/h	<b>5.1 mph</b>	8.3 km/h	<b>5.1 mph</b>
3rd	14.6 km/h	<b>9.0 mph</b>	14.6 km/h	<b>9.0 mph</b>
Track Roller Frame	<b>7</b>		<b>8</b>	
Width of Standard Track Shoe	560 mm	<b>22"</b>	760 mm	<b>30"</b>
Track Gauge	2160 mm	<b>85"</b>	2160 mm	<b>85"</b>
General Dimensions:				
Height (To Top of ROPS)	3298 mm	<b>129.8"</b>	3298 mm	<b>129.8"</b>
Overall Length:				
With Blade and Winch	5286 mm	<b>255.2"</b>	—	—
With Blade and Maximum Boom Reach	—	—	8166 mm	<b>321.5"</b>
With Blade and Minimum Boom Reach	—	—	6137 mm	<b>241.6"</b>
Width (without Trunnion)	2720 mm	<b>107"</b>	2720 mm	<b>107"</b>
Ground Clearance	711.2 mm	<b>28"</b>	711.2 mm	<b>28"</b>
Capacity:				
Fuel Tank	284 L	<b>75 U.S. gal</b>	284 L	<b>75 U.S. gal</b>
PAT Blade Widths:				
Straight	3.35 m	<b>132"</b>	3.17 m	<b>125"</b>
Angle (25°)	3.10 m	<b>122"</b>	2.92 m	<b>115"</b>

\*All models include coolant, lubricants, full fuel tank, and operator.

527 Cable includes lubricants, coolant, ROPS canopy, 100% fuel, operator, 5P blade, open cab, and towing winch.

527 Grapple includes lubricants, coolant, ROPS canopy, 100% fuel, operator, 5P blade, track roller guard, 760 mm (**30"**) tri-link track, swing grapple, 2.54 m (**100"**) sorting head, and enclosed cab.

\*\*With 22 mm (**0.88"**) cable.



**Shoe Selection and Ground Pressure**

MODEL	527 (7-roller track frame)		527 (8-roller track frame)	
	Number of Shoes (each side)	41		—
Width of Shoes	560 mm	22"	—	
	610 mm	24"	—	
Length of Track on Ground	—		760 mm	30"
	2846 mm	112"	3061 mm	121"
Track Gauge	2160 mm	85"	2160 mm	85"
Ground Contact Area with:				
560 mm (22") Shoes	3.18 m <sup>2</sup>	4928 in <sup>2</sup>	—	
610 mm (24") Shoes	3.47 m <sup>2</sup>	5376 in <sup>2</sup>	—	
760 mm (30") Tri-link	—		4.65 m <sup>2</sup>	7208 in <sup>2</sup>
Ground Pressure (Grapple):				
760 mm (30") Tri-link	—		0.47 kg/cm <sup>2</sup>	6.70 psi
Ground Pressure (Cable):				
560 mm (22") Shoes	0.59 kg/cm <sup>2</sup>	8.37 psi	—	
610 mm (24") Shoes	0.54 kg/cm <sup>2</sup>	7.74 psi	—	

**Winch Specifications**

MODEL	527 Cable	
Maximum Line Pull	93 822 N-m	69,200 lb
Maximum Line Speed	43.6 m/min	143 fpm
Drum Capacity:		
Recommended	122 m	400'0"
Cable Size:		
Recommended	19 mm	0.75"
Drum Diameter	254 mm	10.0"
Drum Width	330 mm	13.0"
Weight	1497 kg	3300 lb

**MACHINE DIMENSIONS** (All dimensions are approximate.)

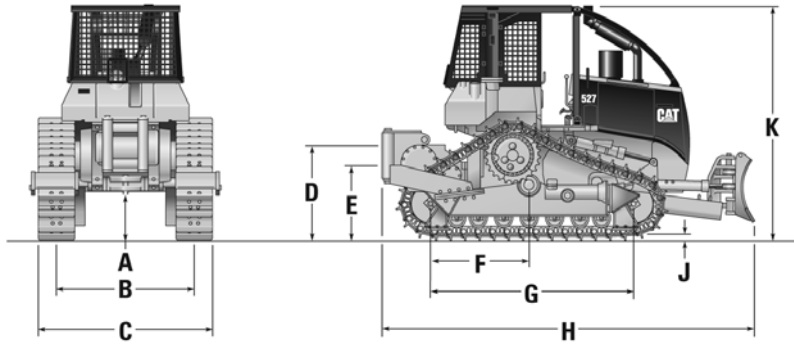

MODEL	527 Cable	
<b>A</b> Ground Clearance	712 mm	28"
<b>B</b> Track Gauge	2160 mm	85"
<b>C</b> Shipping Width*	2720 mm	107"
<b>D</b> Height to Top of Drum	1339 mm	53"
<b>E</b> Height to Center of Drum	1048 mm	41"
<b>F</b> Pivot Shaft to Rear Idler**	1380 mm	54"
<b>G</b> Length of Track on Ground**	2846 mm	112"
<b>H</b> Shipping Length	5286 mm	208.1"
<b>J</b> Grouser Height	65 mm	2.6"
<b>K</b> Shipping Height	3298 mm	129.8"

\*With 560 mm (22") Track Shoes.  
\*\*With 7-Roller Track Frame.

**MACHINE DIMENSIONS** (All dimensions are approximate.)

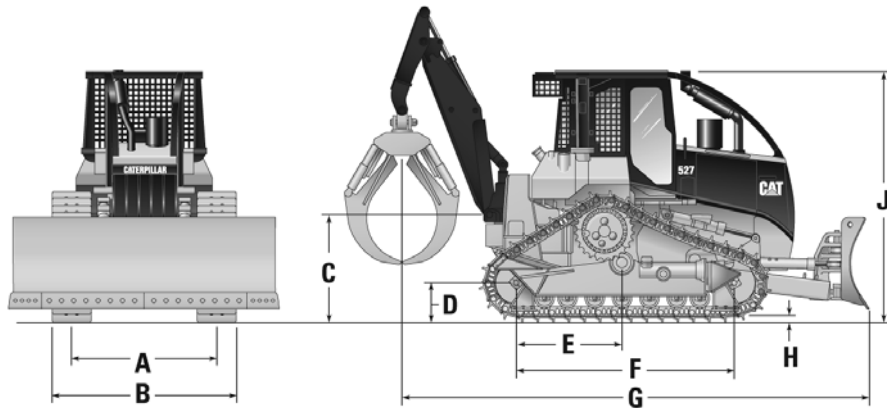

MODEL	527 Swing Boom	
<b>A</b> Track Gauge	2160 mm	85"
<b>B</b> Shipping Width*	3020 mm	118.9"
<b>C</b> Height to Swing Boom Pivot Pin	1408 mm	55"
<b>D</b> Height to Center of Idlers	452 mm	18"
<b>E</b> Pivot Shaft to Rear Idler**	1595 mm	62.8"
<b>F</b> Length of Track on Ground**	3061 mm	121"
<b>G</b> Overall Length — Boom Retracted	6137 mm	241.6"
Overall Length — Boom Extended (not shown)	8166 mm	321.5"
<b>H</b> Grouser Height	65 mm	2.6"
<b>J</b> Shipping Height	3298 mm	129.8"

\*With 760 mm (30") Track Shoes.

\*\*With 8-Roller Track Frame.

### 527 SKIDDER

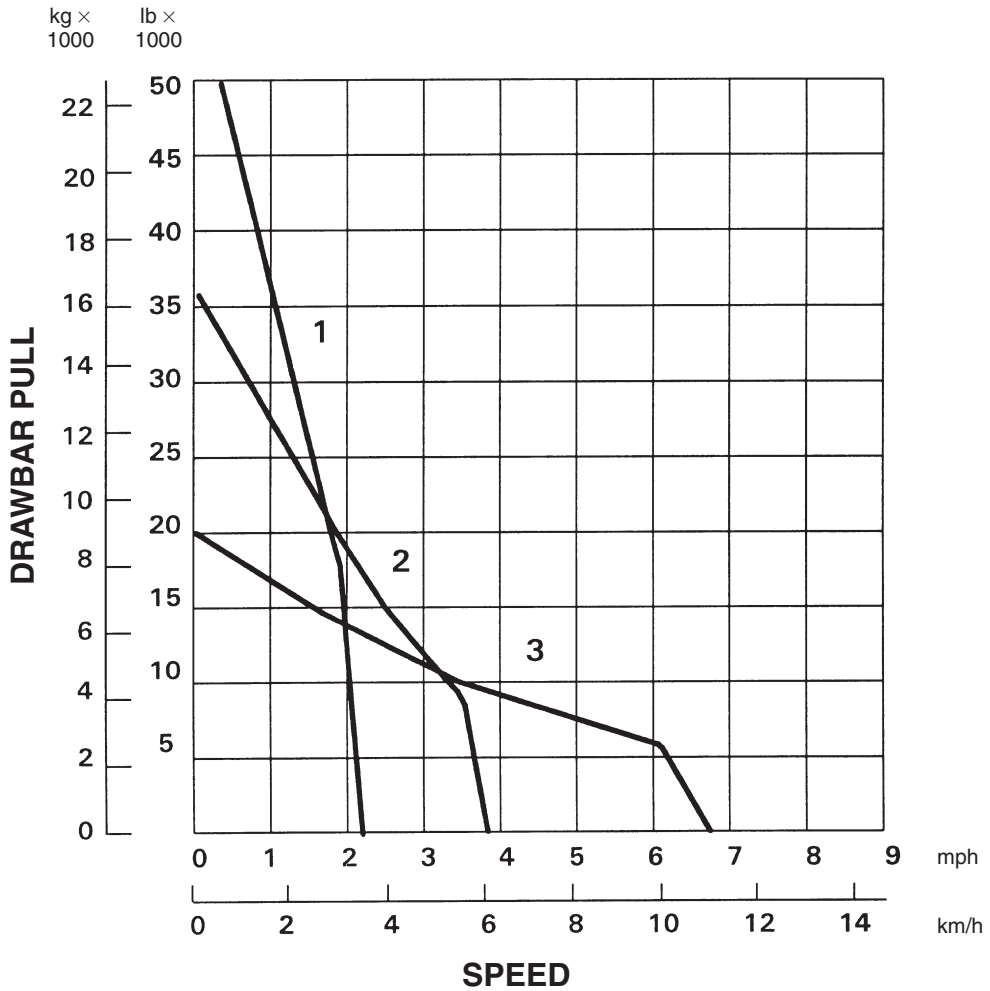

- KEY
- 1 — 1st Gear
  - 2 — 2nd Gear
  - 3 — 3rd Gear

**NOTE:** Usable pull will depend upon weight and traction of equipped tractor.

**BOOM AND GRAPPLES**

The following contains information on some of the available models, which are presented here to suggest a range of grapple possibilities.

**Reach (A, B)** — The horizontal distance from the vertical center of the rear idler to the vertical center of the grapple fore and aft pivot.

- A) With the grapple in its lowest fully extended position.
- B) With the grapple in its highest fully retracted position.

**Lift (C, D, E)** — The vertical distance from the ground to the center of the grapple fore and aft pivot.

- C) With the grapple in its highest fully extended position.
- D) With the grapple in its highest fully retracted position.
- E) With the grapple in its lowest fully extended position.

**Maximum Grapple Opening (K)** — The horizontal distance between the tips of the grapple arms when grapple is fully open.

**Area of Opening (L)** — The available area with grapple in tips together position.

**Minimum Log Size (M)** — The smallest diameter which the grapple can close.

**Grapple Length (N, O, P)** — The distance from the grapple fore and aft pivot to tips of grapple arms.

- N) With grapple fully open.
- O) With grapple in tips together position.
- P) With grapple fully closed.

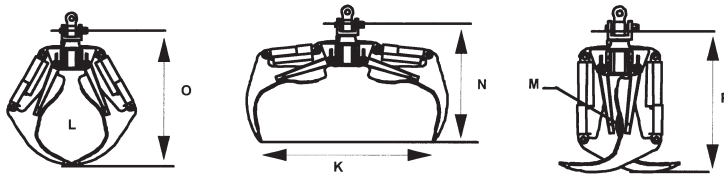

**Sorting Grapple**

- Used for 305 mm (12") or larger diameter trees.
- Designed to pick up individual or several stems for quick cycles.

**Bunching Grapple**

- Used for 305 mm (12") or smaller diameter trees.
- Designed to gather bundle of stems and maximize grapple loads.

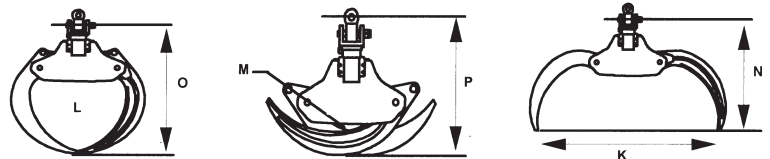

<b>Grapples for 527</b>	<b>K</b>	<b>L</b>	<b>M</b>	<b>N</b>	<b>O</b>	<b>P</b>
2.54 m (100") Sorting	2540 mm <b>100"</b>	0.84 m <sup>2</sup> <b>9 ft<sup>2</sup></b>	76 mm <b>3"</b>	1560 mm <b>61.5"</b>	2040 mm <b>80.5"</b>	1830 mm <b>72"</b>
2.79 m (110") Bunching	2794 mm <b>110"</b>	0.93 m <sup>2</sup> <b>10 ft<sup>2</sup></b>	76 mm <b>3"</b>	1780 mm <b>70"</b>	2020 mm <b>79.5"</b>	1360 mm <b>53.5"</b>

**Swing-boom**

- Ability to reach and lift over the side to collect scattered logs.
- Has decking and loading capability.
- Excellent reach to the rear and side for maximum skidder versatility.
- Suitable for hard to reach timber on steep slopes, soft ground, or selection harvest and thinning.
- Reduces cycle times by reducing the amount of maneuvering of the skidder to reach logs.

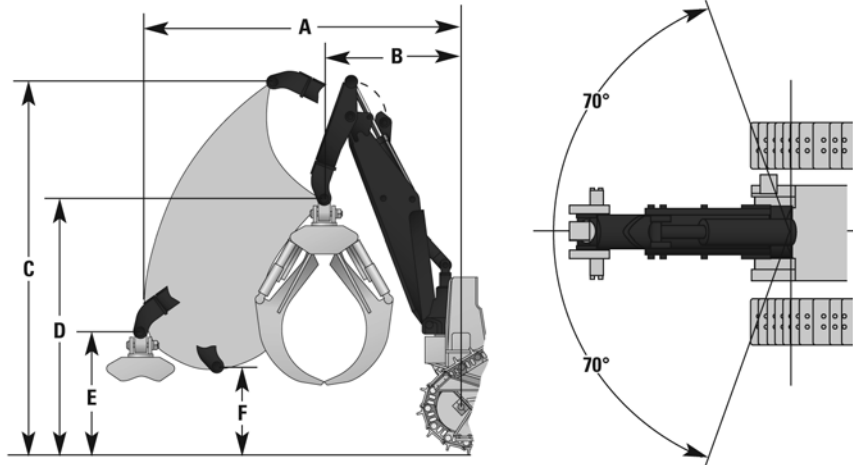

Swing-boom		A	B	C	D	E	F
527	mm	3601	1500	4107	2741	1483	1242
	in	142	59	162	108	58	49

**Sustainability:**

- **Major structures and components** are built to be rebuilt, reducing waste and replacement costs.
- **ACERT Technology** reduces engine emissions at point of combustion with less moving parts for lower operating costs.

**534/544/564/574 Features:**

- **Field-proven Cat engines with ACERT Technology**, along with a torque converter power shift transmission.
- **Large high visibility cab** with scratch resistant 1.27 cm (0.5 in) tinted polycarbonate windows and side windows with escape.

- **Hydraulic tilt** gives complete under cab service access.
- **Extra heavy frame** with full 40 degree articulation for tight turning.
- **Purpose-built blade** with wear resistant front cutting edge.
- **Rear mounted loader** with durable rack and pinion swing system.
- **Full load high reach boom.**
- **250 degree rotation.**
- **European style butt-bypass clam** built with high strength steel dampener.

<b>MODEL</b>	<b>534 (4-wheel)</b>		<b>544 (6-wheel)</b>		<b>564 (6-wheel)</b>		<b>574 (8-wheel)</b>	
Gross Power	93 kW	<b>125 hp</b>	93 kW	<b>125 hp</b>	129 kW	<b>173 hp</b>	129 kW	<b>173 hp</b>
Operating Weight	12 247 kg	<b>27,000 lb</b>	14 062 kg	<b>31,000 lb</b>	16 330 kg	<b>36,000 lb</b>	17 237 kg	<b>38,000 lb</b>
Engine Model	<b>C4.4 ACERT</b>		<b>C4.4 ACERT</b>		<b>C6.6 ACERT</b>		<b>C6.6 ACERT</b>	
Maximum Forward Speed	23.3 km/h	<b>14.5 mph</b>	23.3 km/h	<b>14.5 mph</b>	23.3 km/h	<b>14.5 mph</b>	23.3 km/h	<b>14.5 mph</b>
Loader Reach	6900 mm	<b>22'9"</b>	6900 mm	<b>22'9"</b>	6.9 m	<b>22'9"</b>	6.9 m	<b>22'9"</b>
Load Capacity	7258 kg	<b>16,000 lb</b>	10 866 kg	<b>24,000 lb</b>	13 608 kg	<b>30,000 lb</b>	14 525 kg	<b>32,000 lb</b>
Fuel Capacity	178 L	<b>47.0 U.S. gal</b>	178 L	<b>47.0 U.S. gal</b>	178 L	<b>47 U.S. gal</b>	178 L	<b>47 U.S. gal</b>
Transmission	<b>Electric Powershift</b>		<b>Electric Powershift</b>		<b>Electric Powershift</b>		<b>Electric Powershift</b>	
General Dimensions:								
Wheelbase	3835 mm	<b>151"</b>	5334 mm	<b>210"</b>	5334 mm	<b>210"</b>	5334 mm	<b>210"</b>
Ground Clearance	549 mm	<b>21.6"</b>	579 mm	<b>22.8"</b>	579 mm	<b>22.8"</b>	579 mm	<b>22.8"</b>

**Sustainability:**

- **Major structures and components** are built to be rebuilt, reducing waste and replacement costs.
- **ACERT Technology** reduces engine emissions at point of combustion with less moving parts for lower operating costs.
- **Speed modulated hydraulically driven cooling fan** for decreased power requirements resulting in reduced fuel consumption.
- **1800 rpm engine** for reduced engine speeds to provide increased fuel economy.

**584/584HD Features:**

- **Cat C7 ACERT engine** with 1800 rpm rating and excellent torque in the 1400 to 1600 rpm range for increased fuel efficiency.
- **Enlarged hydraulic cooling capacity** to provide high heat rejection capability for extended component life.
- **Hydraulic driven cooling fan** with speed modulation for reduced fuel consumption and maintaining optimal system temperatures for better component performance.

- **Hydrostatic drive system** for infinitely variable speed at peak power and dynamic braking for steep terrain.
- **8.5C drive line components** provide superior strength and service life for reduced maintenance costs.
- **Robust front and rear frame structures** provide the ability to rebuild/relife to reduce overall ownership costs and increase resale values.
- **Heavy duty cast articulation and large oscillation bearing** designed to provide a long service life.
- **Ergonomic cab** with automatic temperature control, air suspension seat, storage compartments, and low effort joy stick controls.
- **Drop down side window** design for enhanced visibility to the work area close to the machine and in front of all wheels.
- **Front entry door** provides easy access off of a hydraulic lift stairway and platform.
- **Forward tilting engine hood and hydraulic tilt cab** for easy service access.

MODEL	584 (6-wheel)		584 (8-wheel)		584HD (8-wheel)	
Gross Power	204 kW	274 hp	204 kW	274 hp	204 kW	274 hp
Operating Weight	20 230 kg	44,600 lb	22 498 kg	49,600 lb	23 088 kg	50,900 lb
Engine Model	C7 ACERT		C7 ACERT		C7 ACERT	
Maximum Tractive Force	210 kN	47,169 lb-f	210 kN	47,169 lb-f	226 kN	50,864 lb-f
Maximum Speed	22.5 km/h	14.0 mph	22.5 km/h	14.0 mph	20.9 km/h	13.0 mph
STD Loader Reach	7.8 m	25.6 ft	7.8 m	25.6 ft	7.8 m	25.6 ft
Loader Lifting Torque (gross)	151 kN-m	111,372 lb-f-ft	151 kN-m	111,372 lb-f-ft	151 kN-m	111,372 lb-f-ft
Load Capacity	18 000 kg	39,683 lb	18 000 kg	39,683 lb	20 000 kg	44,092 lb
Fuel Capacity	255 L	67.3 U.S. gal	255 L	67.3 U.S. gal	255 L	67.3 U.S. gal
Transmission	2 speed hydrostatic		2 speed hydrostatic		2 speed hydrostatic	
General Dimensions:						
Wheelbase	6096 mm	240"	6096 mm	240"	6096 mm	240"
Bogie Spread (center to center)	1690 mm	66.5"	1690 mm	66.5"	1890 mm	74.4"
Ground Clearance	692 mm	27.3"	692 mm	27.3"	692 mm	27.3"



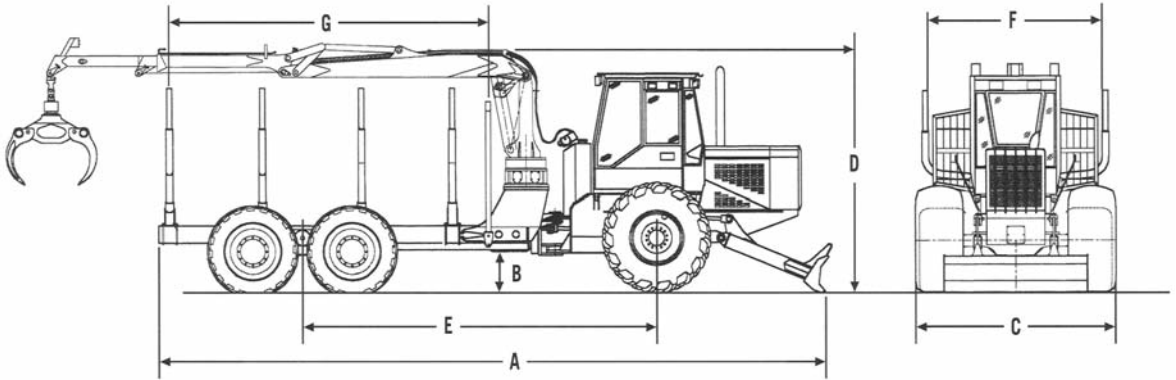

<b>MODEL</b>	<b>534 (4-wheel)</b>		<b>544 (6-wheel)</b>		<b>564 (6-wheel)</b>		<b>574 (8-wheel)</b>	
<b>A</b> Length with:								
2.92 m (9.6') Load Deck	7840 mm	309"	—	—	—	—	—	—
3.35 m (11.5') Load Deck	8430 mm	332"	—	—	—	—	—	—
4.88 m (16') Load Deck	9880 mm	389"	9750 mm	384"	10 210 mm	402"	10 210 mm	402"
5.64 m (18.5') Load Deck	—	—	—	—	10 970 mm	432"	10 970 mm	432"
<b>B</b> Ground Clearance	549 mm	21.6"	579 mm	22.8"	579 mm	22.8"	579 mm	22.8"
<b>C</b> Width with Standard Tires	2642 mm	104"	2642 mm	104"	2997 mm	118"	3048 mm	120"
<b>D</b> Transport Height	3454 mm	136"	3581 mm	141"	3581 mm	141"	3581 mm	141"
<b>E</b> Wheelbase with:								
2.92 m (9.6') Load Deck	3835 mm	151"	—	—	—	—	—	—
3.35 m (11.5') Load Deck	4394 mm	173"	—	—	—	—	—	—
4.88 m (16') Load Deck	5385 mm	212"	5334 mm	210"	5334 mm	210"	5334 mm	210"
5.64 m (18.5') Load Deck	—	—	—	—	5715 mm	225"	5715 mm	225"
<b>F</b> Load Stake Width (Inside)	2362 mm	93"	2362 mm	93"	2591 mm	102"	2591 mm	102"
<b>G</b> Length of Standard Wood Bunk	2920 mm	9.6'	4880 mm	16'	4880 mm	16'	4880 mm	16'
Optional Length 1	3350 mm	11.5'	—	—	5640 mm	18.5'	5640 mm	18.5'
Optional Length 2	4880 mm	16'	—	—	—	—	—	—

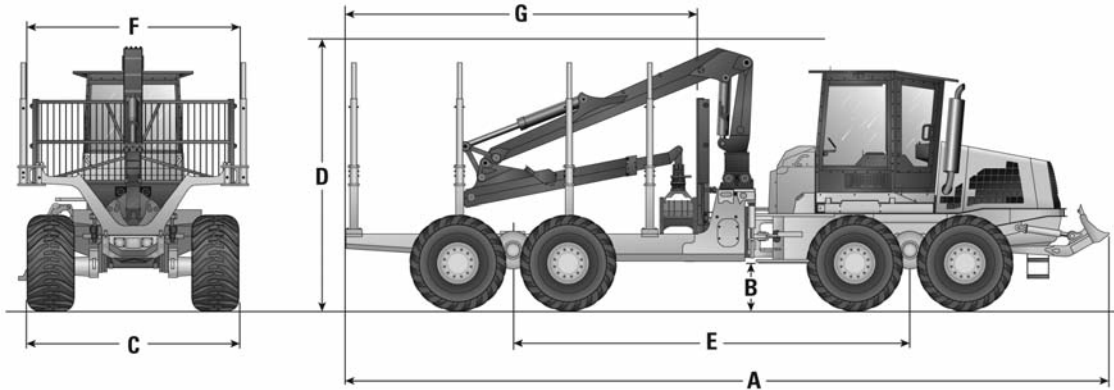

6

MODEL	584 (6-wheel)		584 (8-wheel)		584HD (8-wheel)	
<b>A</b> Length with Blade	11 755 mm	463"	11 755 mm	463"	11 755 mm	463"
<b>B</b> Ground Clearance	692 mm	27.3"	692 mm	27.3"	692 mm	27.3"
<b>C</b> Width with Standard Tires	3180 mm	125.2"	3180 mm	125.2"	3180 mm	125.2"
<b>D</b> Transport Height	4163 mm	163.9"	4163 mm	163.9"	4163 mm	163.9"
<b>E</b> Wheelbase	6096 mm	240"	6096 mm	240"	6096 mm	240"
<b>F</b> Load Stake Width (Inside) with:						
Standard Bunk	2769 mm	109"	2769 mm	109"	2769 mm	109"
Optional Bunk	3264 mm	128.5"	3264 mm	128.5"	3264 mm	128.5"
<b>G</b> Length of Wood Bunk	5410 mm	213"	5410 mm	213"	5410 mm	213"

## Introduction

Cat forestry machines are specifically designed for tough forest work. Each model uses purpose built booms, sticks and grapples designed by Caterpillar for maximum performance and durability.

The following information provides features, specifications, dimensions, working ranges and major component weights for the 320D FM, 324D FM, 325D FM and 330D FM.

## Features

### 320D FM

- **The Cat C6.4 engine** provides power, low emissions, outstanding reliability, and maximizes fuel economy.
- **Various configurations** for demanding applications including Harvester, Log Loader, Slasher, Road Builder, Thumb, Grapple Saw and Processor.
- **Rugged undercarriage design and proven structural components** provide outstanding durability.
- **Track roller frames** are robot-welded and pressed formed, pentagonal units to deliver exceptional strength and service life.
- **Undercarriage** — Forestry machine configuration options allow you to choose the right machine for your application.
- **Operator station** — Redesigned interior layout maximizes operator space, provides exceptional comfort and reduces operator fatigue.
- **Serviceability** — Longer service intervals and easier maintenance result in better machine availability and lower costs.

### 324D FM/325D FM

- **Cat C7 ACERT engine** provides exceptional power and fuel efficiency, meeting U.S. EPA emissions requirements.
- **Attachments** — Factory installed Log Loader fronts with Live Heel and Cat Grapples; Harvester, Road Builder and Butt-n-Top fronts; AEM delimeter carrier options help meet diverse forest applications.
- **Cat GLL forestry grapples**, built with high-grade steel throughout the grapple, matched with Cat Forest Machines provide high performance and reliability in logging applications.

- **Rugged main frame design** is purpose-built for forest applications with reinforced carbody, rugged swing bearing, heavy doors and extra guarding.
- **Operator station** — Redesigned interior layout maximizes operator space and provides exceptional comfort. Roomy, quiet, automatically climate controlled cab has excellent sightlines to the work area.
- **Serviceability** — Simplified service and maintenance, and electronic diagnostics help save time, money and increase productivity.

### 330D FM

- **Cat C9 ACERT engine** provides exceptional power and fuel efficiency, meeting U.S. EPA emissions requirements.
- **Attachments** — Factory installed Log Loader fronts with Live Heel and Cat Grapples; Harvester, Road Builder and Butt-n-Top fronts; AEM delimeter carrier options help meet diverse forest applications.
- **Cat GLL forestry grapples**, built with high-grade steel throughout the grapple, matched with Cat Forest Machines provide high performance and reliability in logging applications.
- **Reinforced carbody design** stands up to the most demanding forest applications, assuring outstanding durability and service life.
- **Undercarriage** — Heavy-duty link assemblies provide toughness and durability, maximizing undercarriage life and minimizing operating costs.
- **Guarding** — Purpose designed guarding helps extend service life, reduces downtime and helps protect your forestry machine investment.
- **Operator station** — Spacious, quiet, automatically climate controlled cab has excellent sightlines to the work area.
- **Serviceability** — Simplified service and maintenance, and electronic diagnostics help save time, money and increase productivity.

MODEL	320D FM General Forestry (HD/LC)		320D FM General Forestry (HW)		320D FM Log Loader (U/U)	
	Flywheel Power	117 kW	157 hp	117 kW	157 hp	117 kW
Operating Weight	25 500 kg	56,228 lb	26 900 kg	59,315 lb	30 300 kg	66,812 lb
Swing Mechanism:						
Torque	61.8 kN·m	45,611 lb-ft	61.8 kN·m	45,611 lb-ft	61.8 kN·m	45,611 lb-ft
Speed	11.5 RPM		11.5 RPM		11.5 RPM	
Engine Model	C6.4		C6.4		C6.4	
No. of Cylinders	6		6		6	
Bore	102 mm	4"	102 mm	4"	102 mm	4"
Stroke	130 mm	5.1"	130 mm	5.1"	130 mm	5.1"
Displacement	6.4 L	390 in <sup>3</sup>	6.4 L	390 in <sup>3</sup>	6.4 L	390 in <sup>3</sup>
Hydraulic System:						
Main Implement System — Maximum Flow (2X)	205 L/min	54.2 gpm	205 L/min	54.2 gpm	205 L/min	54.2 gpm
Relief Valve Settings:						
Implement Circuits	35 000 kPa	5075 psi	35 000 kPa	5075 psi	35 000 kPa	5075 psi
Travel Circuits	35 000 kPa	5075 psi	35 000 kPa	5075 psi	35 000 kPa	5075 psi
Swing Circuits	25 000 kPa	3625 psi	25 000 kPa	3625 psi	25 000 kPa	3625 psi
Pilot Circuits	4120 kPa	600 psi	4120 kPa	600 psi	4120 kPa	600 psi
Drive:						
Maximum Drawbar Pull	188 kN	42,264 lb	248 kN	55,700 lb	248 kN	55,700 lb
Maximum Travel Speed	5.3 km/h	3.3 mph	4.3 km/h	2.6 mph	4.3 km/h	2.6 mph
Log Loader Linkage:						
Boom Cylinder — Bore	140 mm	5.5"	140 mm	5.5"	140 mm	5.5"
Boom Cylinder — Stroke	1160 mm	45.7"	1160 mm	45.7"	1160 mm	45.7"
Stick Cylinder — Bore	150 mm	5.9"	150 mm	5.9"	150 mm	5.9"
Stick Cylinder — Stroke	1470 mm	57.9"	1470 mm	57.9"	1470 mm	57.9"
Under/Under Heel Cylinder — Bore	—	—	—	—	130 mm	5.1"
Under/Under Heel Cylinder — Stroke	—	—	—	—	1156 mm	45.5"
Track:						
Standard (HD double grouser)	700 mm	28"	700 mm	28"	700 mm	28"
Optional (HD double grouser)	600 mm	24"	600 mm	24"	600 mm	24"
Optional (HD triple grouser)	700 mm	28"	700 mm	28"	700 mm	28"
Overall Track Length	4480 mm	14'8"	4555 mm	14'11"	4555 mm	14'11"
Ground Clearance	475 mm	1'7"	650 mm	2'2"	650 mm	2'2"
Track Gauge	2380 mm	7'10"	2590 mm	8'6"	2590 mm	8'6"
Capacity:						
Fuel Tank	410 L	108.3 U.S. gal	410 L	108.3 U.S. gal	410 L	108.3 U.S. gal
Cooling System	25 L	6.6 U.S. gal	—	—	25 L	6.6 U.S. gal
Engine Oil	30 L	7.9 U.S. gal	30 L	7.9 U.S. gal	30 L	7.9 U.S. gal
Swing Drive	8 L	2.1 U.S. gal	—	—	8 L	2.1 U.S. gal
Hydraulic System — Total	260 L	68.7 U.S. gal	260 L	68.7 U.S. gal	260 L	68.7 U.S. gal
Hydraulic System — Tank	125 L	33.0 U.S. gal	125 L	33.0 U.S. gal	125 L	33.0 U.S. gal
Final Drive (each)	13 L	3.4 U.S. gal	10 L	2.6 U.S. gal	13 L	3.4 U.S. gal

<b>MODEL</b>	<b>324D FM</b> General Forestry		<b>324D FM</b> Log Loader (U/U)		<b>324D FM</b> Log Loader (O/U)	
Flywheel Power	140 kW	<b>188 hp</b>	140 kW	<b>188 hp</b>	140 kW	<b>188 hp</b>
Operating Weight (with front linkage, without bucket or grapple)	31 226 kg	<b>68,853 lb</b>	34 330 kg	<b>75,698 lb</b>	34 484 kg	<b>76,037 lb</b>
Swing Mechanism:						
Torque	73.4 kN-m	<b>54,147 lb-ft</b>	73.4 kN-m	<b>54,147 lb-ft</b>	73.4 kN-m	<b>54,147 lb-ft</b>
Speed	<b>10 RPM</b>		<b>10 RPM</b>		<b>10 RPM</b>	
Engine Model	<b>C7 ACERT</b>		<b>C7 ACERT</b>		<b>C7 ACERT</b>	
No. of Cylinders	<b>6</b>		<b>6</b>		<b>6</b>	
Bore	110 mm	<b>4.3"</b>	110 mm	<b>4.3"</b>	110 mm	<b>4.3"</b>
Stroke	127 mm	<b>5"</b>	127 mm	<b>5"</b>	127 mm	<b>5"</b>
Displacement	7.2 L	<b>440 in³</b>	7.2 L	<b>440 in³</b>	7.2 L	<b>440 in³</b>
Hydraulic System:						
Main Implement System — Maximum Flow (2X)	220 L/min	<b>58.1 gpm</b>	220 L/min	<b>58.1 gpm</b>	220 L/min	<b>58.1 gpm</b>
Relief Valve Settings:						
Implement Circuits	35 000 kPa	<b>5075 psi</b>	35 000 kPa	<b>5075 psi</b>	35 000 kPa	<b>5075 psi</b>
Travel Circuits	35 000 kPa	<b>5075 psi</b>	35 000 kPa	<b>5075 psi</b>	35 000 kPa	<b>5075 psi</b>
Swing Circuits	24 500 kPa	<b>3553 psi</b>	24 500 kPa	<b>3553 psi</b>	24 500 kPa	<b>3553 psi</b>
Pilot Circuits	3920 kPa	<b>568 psi</b>	3920 kPa	<b>568 psi</b>	3920 kPa	<b>568 psi</b>
Drive:						
Maximum Drawbar Pull	259 kN	<b>58,226 lb</b>	259 kN	<b>58,226 lb</b>	259 kN	<b>58,226 lb</b>
Maximum Travel Speed	5.7 km/h	<b>3.5 mph</b>	5.7 km/h	<b>3.5 mph</b>	5.7 km/h	<b>3.5 mph</b>
Log Loader Linkage:						
Boom Cylinder — Bore	140 mm	<b>5.5"</b>	140 mm	<b>5.5"</b>	140 mm	<b>5.5"</b>
Boom Cylinder — Stroke	1185 mm	<b>46.7"</b>	1185 mm	<b>46.7"</b>	1185 mm	<b>46.7"</b>
Stick Cylinder — Bore	170 mm	<b>6.7"</b>	170 mm	<b>6.7"</b>	170 mm	<b>6.7"</b>
Stick Cylinder — Stroke	1680 mm	<b>66.1"</b>	1680 mm	<b>66.1"</b>	1680 mm	<b>66.1"</b>
Under/Under Heel Cylinder — Bore	—		130 mm	<b>5.1"</b>	—	
Under/Under Heel Cylinder — Stroke	—		1156 mm	<b>45.5"</b>	—	
Over/Under Heel Cylinder — Bore	—		—		150 mm	<b>5.9"</b>
Over/Under Heel Cylinder — Stroke	—		—		1470 mm	<b>57.9"</b>
Track:						
Standard (HD double grouser)	700 mm	<b>28"</b>	700 mm	<b>28"</b>	700 mm	<b>28"</b>
Optional (double grouser)	600 mm	<b>24"</b>	600 mm	<b>24"</b>	600 mm	<b>24"</b>
Optional (HD triple grouser)	800 mm	<b>32"</b>	800 mm	<b>32"</b>	800 mm	<b>32"</b>
Overall Track Length	4670 mm	<b>15'4"</b>	4670 mm	<b>15'4"</b>	4670 mm	<b>15'4"</b>
Ground Clearance	710 mm	<b>2'4"</b>	710 mm	<b>2'4"</b>	710 mm	<b>2'4"</b>
Track Gauge	2920 mm	<b>9'7"</b>	2920 mm	<b>9'7"</b>	2920 mm	<b>9'7"</b>
Capacity:						
Fuel Tank (standard)	520 L	<b>137.4 U.S. gal</b>	520 L	<b>137.4 U.S. gal</b>	520 L	<b>137.4 U.S. gal</b>
Fuel Tank (optional auxiliary right front)	410 L	<b>108.3 U.S. gal</b>	410 L	<b>108.3 U.S. gal</b>	410 L	<b>108.3 U.S. gal</b>
Cooling System	30 L	<b>7.9 U.S. gal</b>	30 L	<b>7.9 U.S. gal</b>	30 L	<b>7.9 U.S. gal</b>
Engine Oil	34 L	<b>9.0 U.S. gal</b>	34 L	<b>9.0 U.S. gal</b>	34 L	<b>9.0 U.S. gal</b>
Swing Drive	8 L	<b>2.1 U.S. gal</b>	8 L	<b>2.1 U.S. gal</b>	8 L	<b>2.1 U.S. gal</b>
Hydraulic System — Total	245 L	<b>64.7 U.S. gal</b>	245 L	<b>64.7 U.S. gal</b>	245 L	<b>64.7 U.S. gal</b>
Hydraulic System — Tank	145 L	<b>38.3 U.S. gal</b>	145 L	<b>38.3 U.S. gal</b>	145 L	<b>38.3 U.S. gal</b>
Final Drive (each)	8 L	<b>2.1 U.S. gal</b>	8 L	<b>2.1 U.S. gal</b>	8 L	<b>2.1 U.S. gal</b>

MODEL	325D FM General Forestry (HW)		325D FM Log Loader (U/U)		325D FM Log Loader (O/U)	
Flywheel Power	152 kW	<b>204 hp</b>	152 kW	<b>204 hp</b>	152 kW	<b>204 hp</b>
Operating Weight (with front linkage, without bucket or grapple)	33 329 kg	<b>73,478 lb</b>	37 807 kg	<b>83,350 lb</b>	38 211 kg	<b>84,241 lb</b>
Swing Mechanism:						
Torque	86.3 kN-m	<b>63,664 lb-ft</b>	86.3 kN-m	<b>63,664 lb-ft</b>	86.3 kN-m	<b>63,664 lb-ft</b>
Speed	<b>10 RPM</b>		<b>10 RPM</b>		<b>10 RPM</b>	
Engine Model	<b>C7 ACERT</b>		<b>C7 ACERT</b>		<b>C7 ACERT</b>	
No. of Cylinders	<b>6</b>		<b>6</b>		<b>6</b>	
Bore	110 mm	<b>4.3"</b>	110 mm	<b>4.3"</b>	110 mm	<b>4.3"</b>
Stroke	127 mm	<b>5"</b>	127 mm	<b>5"</b>	127 mm	<b>5"</b>
Displacement	7.2 L	<b>440 in<sup>3</sup></b>	7.2 L	<b>440 in<sup>3</sup></b>	7.2 L	<b>440 in<sup>3</sup></b>
Hydraulic System:						
Main Implement System — Maximum Flow (2X)	235 L/min	<b>62.1 gpm</b>	235 L/min	<b>62.1 gpm</b>	235 L/min	<b>62.1 gpm</b>
Relief Valve Settings:						
Implement Circuits	35 000 kPa	<b>5075 psi</b>	35 000 kPa	<b>5075 psi</b>	35 000 kPa	<b>5075 psi</b>
Travel Circuits	35 000 kPa	<b>5075 psi</b>	35 000 kPa	<b>5075 psi</b>	35 000 kPa	<b>5075 psi</b>
Swing Circuits	27 500 kPa	<b>3988 psi</b>	27 500 kPa	<b>3988 psi</b>	27 500 kPa	<b>3988 psi</b>
Pilot Circuits	4120 kPa	<b>597 psi</b>	4120 kPa	<b>597 psi</b>	4120 kPa	<b>597 psi</b>
Drive:						
Maximum Drawbar Pull	256 kN	<b>57,551 lb</b>	256 kN	<b>57,551 lb</b>	256 kN	<b>57,551 lb</b>
Maximum Travel Speed	5.5 km/h	<b>3.4 mph</b>	5.5 km/h	<b>3.4 mph</b>	5.5 km/h	<b>3.4 mph</b>
Log Loader Linkage:						
Boom Cylinder — Bore	150 mm	<b>5.9"</b>	150 mm	<b>5.9"</b>	150 mm	<b>5.9"</b>
Boom Cylinder — Stroke	1400 mm	<b>55.1"</b>	1400 mm	<b>55.1"</b>	1400 mm	<b>55.1"</b>
Stick Cylinder — Bore	180 mm	<b>7.1"</b>	180 mm	<b>7.1"</b>	180 mm	<b>7.1"</b>
Stick Cylinder — Stroke	1650 mm	<b>65"</b>	1650 mm	<b>65"</b>	1650 mm	<b>65"</b>
Under/Under Heel Cylinder — Bore	—		150 mm	<b>5.9"</b>	—	
Under/Under Heel Cylinder — Stroke	—		1155 mm	<b>45.5"</b>	—	
Over/Under Heel Cylinder — Bore	—		—		160 mm	<b>6.3"</b>
Over/Under Heel Cylinder — Stroke	—		—		1465 mm	<b>57.7"</b>
Track:						
Standard (HD double grouser)	700 mm	<b>28"</b>	700 mm	<b>28"</b>	700 mm	<b>28"</b>
Optional (HD triple grouser)	700 mm	<b>28"</b>	700 mm	<b>28"</b>	700 mm	<b>28"</b>
Overall Track Length	4970 mm	<b>16'4"</b>	4970 mm	<b>16'4"</b>	4970 mm	<b>16'4"</b>
Ground Clearance	740 mm	<b>2'5"</b>	740 mm	<b>2'5"</b>	740 mm	<b>2'5"</b>
Track Gauge	2920 mm	<b>9'7"</b>	2920 mm	<b>9'7"</b>	2920 mm	<b>9'7"</b>
Capacity:						
Fuel Tank (standard)	520 L	<b>137.4 U.S. gal</b>	520 L	<b>137.4 U.S. gal</b>	520 L	<b>137.4 U.S. gal</b>
Fuel Tank — Optional Auxiliary Right Front	410 L	<b>108.3 U.S. gal</b>	410 L	<b>108.3 U.S. gal</b>	410 L	<b>108.3 U.S. gal</b>
Cooling System	30 L	<b>7.9 U.S. gal</b>	30 L	<b>7.9 U.S. gal</b>	30 L	<b>7.9 U.S. gal</b>
Engine Oil	34 L	<b>9.0 U.S. gal</b>	34 L	<b>9.0 U.S. gal</b>	34 L	<b>9.0 U.S. gal</b>
Swing Drive	10 L	<b>2.6 U.S. gal</b>	10 L	<b>2.6 U.S. gal</b>	10 L	<b>2.6 U.S. gal</b>
Hydraulic System — Total	260 L	<b>68.7 U.S. gal</b>	260 L	<b>68.7 U.S. gal</b>	260 L	<b>68.7 U.S. gal</b>
Hydraulic System — Tank	145 L	<b>38.3 U.S. gal</b>	145 L	<b>38.3 U.S. gal</b>	145 L	<b>38.3 U.S. gal</b>
Final Drive (each)	8 L	<b>2.1 U.S. gal</b>	8 L	<b>2.1 U.S. gal</b>	8 L	<b>2.1 U.S. gal</b>

MODEL	330D FM General Forestry (HD)		330D FM Log Loader (U/U)		330D FM Log Loader (O/U)	
Flywheel Power	200 kW	<b>268 hp</b>	200 kW	<b>268 hp</b>	200 kW	<b>268 hp</b>
Operating Weight (with front linkage, without bucket or grapple)	41 426 kg	<b>91,344 lb</b>	45 801 kg	<b>100,991 lb</b>	46 261 kg	<b>102,005 lb</b>
Swing Mechanism:						
Torque	113.9 kN-m	<b>84,024 lb-ft</b>	148.5 kN-m	<b>109,560 lb-ft</b>	148.5 kN-m	<b>109,560 lb-ft</b>
Speed	<b>10 RPM</b>		<b>6.3 RPM</b>		<b>6.3 RPM</b>	
Engine Model	<b>C9 ACERT</b>		<b>C9 ACERT</b>		<b>C9 ACERT</b>	
No. of Cylinders	<b>6</b>		<b>6</b>		<b>6</b>	
Bore	112 mm	<b>4.4"</b>	112 mm	<b>4.4"</b>	112 mm	<b>4.4"</b>
Stroke	149 mm	<b>5.9"</b>	149 mm	<b>5.9"</b>	149 mm	<b>5.9"</b>
Displacement	8.8 L	<b>537 in<sup>3</sup></b>	8.8 L	<b>537 in<sup>3</sup></b>	8.8 L	<b>537 in<sup>3</sup></b>
Hydraulic System:						
Main Implement System — Maximum Flow (2X)	280 L/min	<b>74 gpm</b>	280 L/min	<b>74 gpm</b>	280 L/min	<b>74 gpm</b>
Relief Valve Settings:						
Implement Circuits	35 000 kPa	<b>5075 psi</b>	35 000 kPa	<b>5075 psi</b>	35 000 kPa	<b>5075 psi</b>
Travel Circuits	35 000 kPa	<b>5075 psi</b>	35 000 kPa	<b>5075 psi</b>	35 000 kPa	<b>5075 psi</b>
Swing Circuits	27 900 kPa	<b>4046 psi</b>	27 900 kPa	<b>4046 psi</b>	27 900 kPa	<b>4046 psi</b>
Pilot Circuits	4100 kPa	<b>595 psi</b>	4100 kPa	<b>595 psi</b>	4100 kPa	<b>595 psi</b>
Drive:						
Maximum Drawbar Pull	317 kN	<b>71,264 lb</b>	317 kN	<b>71,264 lb</b>	317 kN	<b>71,264 lb</b>
Maximum Travel Speed	4.8 km/h	<b>3 mph</b>	4.8 km/h	<b>3 mph</b>	4.8 km/h	<b>3 mph</b>
Log Loader Linkage:						
Boom Cylinder — Bore	170 mm	<b>6.7"</b>	170 mm	<b>6.7"</b>	170 mm	<b>6.7"</b>
Boom Cylinder — Stroke	1340 mm	<b>52.8"</b>	1340 mm	<b>52.8"</b>	1340 mm	<b>52.8"</b>
Stick Cylinder — Bore	180 mm	<b>7.1"</b>	180 mm	<b>7.1"</b>	180 mm	<b>7.1"</b>
Stick Cylinder — Stroke	1661 mm	<b>65.4"</b>	1661 mm	<b>65.4"</b>	1661 mm	<b>65.4"</b>
Under/Under Heel Cylinder — Bore	—		150 mm	<b>5.9"</b>	—	
Under/Under Heel Cylinder — Stroke	—		1155 mm	<b>45.5"</b>	—	
Over/Under Heel Cylinder — Bore	—		—		160 mm	<b>6.3"</b>
Over/Under Heel Cylinder — Stroke	—		—		1465 mm	<b>57.7"</b>
Track:						
Standard (HD double grouser)	700 mm	<b>28"</b>	700 mm	<b>28"</b>	700 mm	<b>28"</b>
Optional (HD triple grouser)	850 mm	<b>34"</b>	850 mm	<b>34"</b>	850 mm	<b>34"</b>
Overall Track Length	5060 mm	<b>16'7"</b>	5060 mm	<b>16'7"</b>	5060 mm	<b>16'7"</b>
Ground Clearance	760 mm	<b>2'6"</b>	760 mm	<b>2'6"</b>	760 mm	<b>2'6"</b>
Track Gauge	2920 mm	<b>9'7"</b>	2920 mm	<b>9'7"</b>	2920 mm	<b>9'7"</b>
Capacity:						
Fuel Tank (standard)	600 L	<b>158.5 U.S. gal</b>	600 L	<b>158.5 U.S. gal</b>	600 L	<b>158.5 U.S. gal</b>
Fuel Tank — Optional Auxiliary Right Front	410 L	<b>108.3 U.S. gal</b>	410 L	<b>108.3 U.S. gal</b>	410 L	<b>108.3 U.S. gal</b>
Cooling System	38 L	<b>10.0 U.S. gal</b>	38 L	<b>10.0 U.S. gal</b>	38 L	<b>10.0 U.S. gal</b>
Engine Oil	36 L	<b>9.5 U.S. gal</b>	36 L	<b>9.5 U.S. gal</b>	36 L	<b>9.5 U.S. gal</b>
Swing Drive	19 L	<b>5.0 U.S. gal</b>	19 L	<b>5.0 U.S. gal</b>	19 L	<b>5.0 U.S. gal</b>
Hydraulic System — Total	410 L	<b>108.3 U.S. gal</b>	410 L	<b>108.3 U.S. gal</b>	410 L	<b>108.3 U.S. gal</b>
Hydraulic System — Tank	175 L	<b>46.2 U.S. gal</b>	175 L	<b>46.2 U.S. gal</b>	175 L	<b>46.2 U.S. gal</b>
Final Drive (each)	8 L	<b>2.1 U.S. gal</b>	8 L	<b>2.1 U.S. gal</b>	8 L	<b>2.1 U.S. gal</b>

**General Forestry**  
HD/LC 5.9 m (19'4") Boom  
with R2.9B1 (9'6") Stick

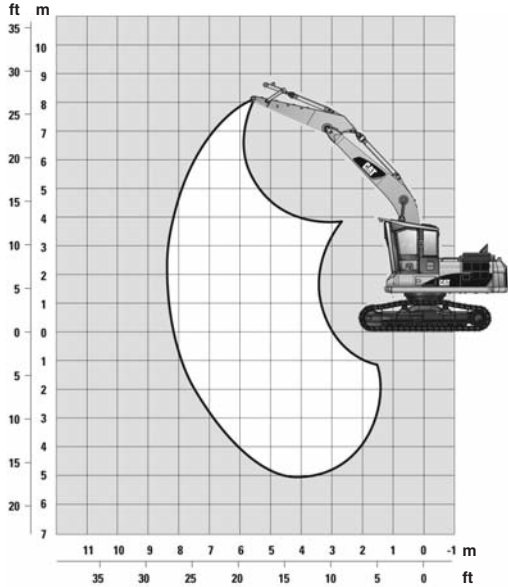

**General Forestry**  
HW 5.9 m (19'4") Boom  
with R2.9B1 (9'6") Stick

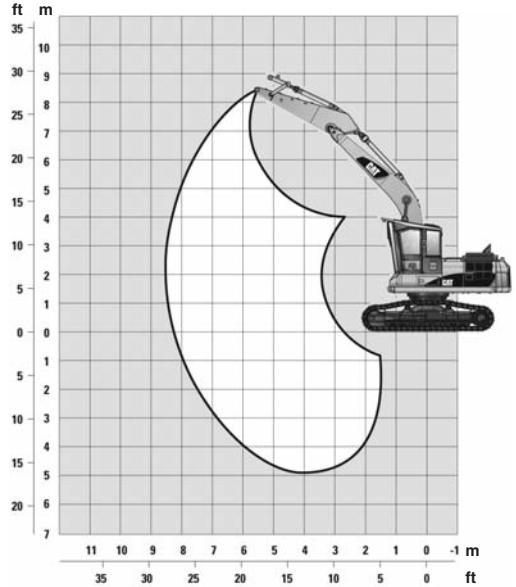

6

**Heel Boom**  
(Under/Under)

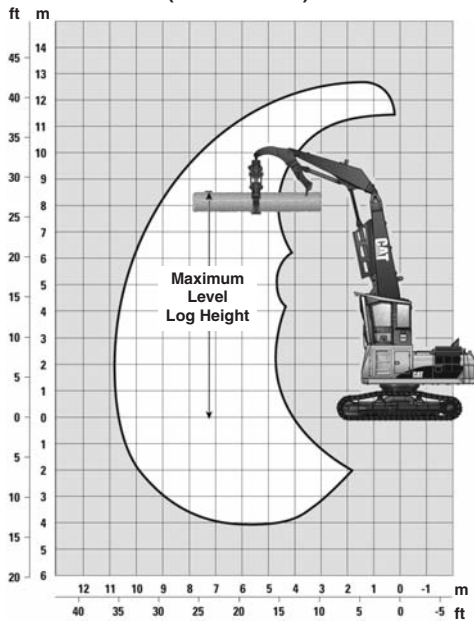



**Heel Boom  
Under/Under**

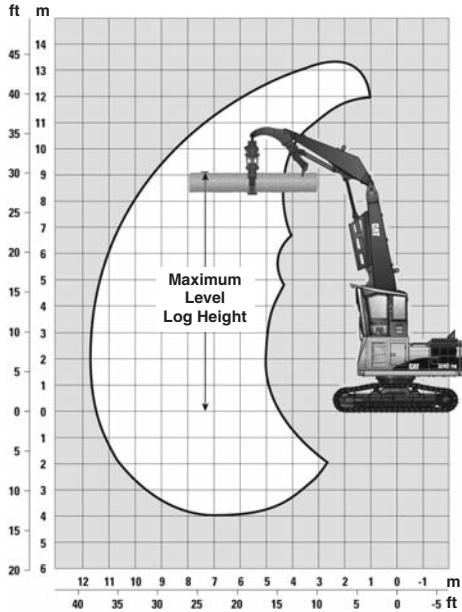

**Heel Boom  
Over/Under**

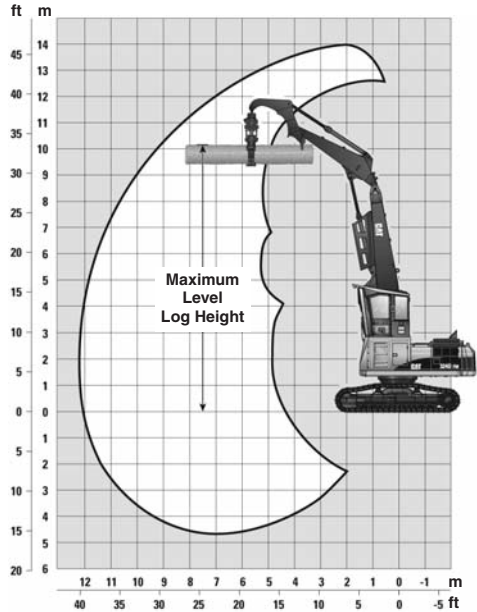

**General Forestry  
HW U/C, 5.9 m (19'4") Boom  
with 2.95S Stick**

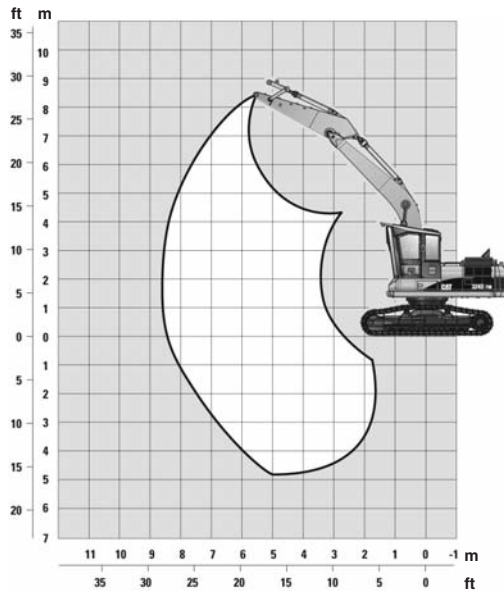

**Heel Boom  
Under/Under**

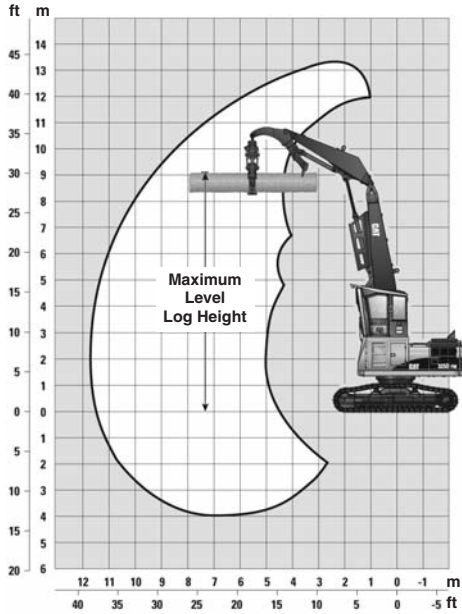

**Heel Boom  
Over/Under**

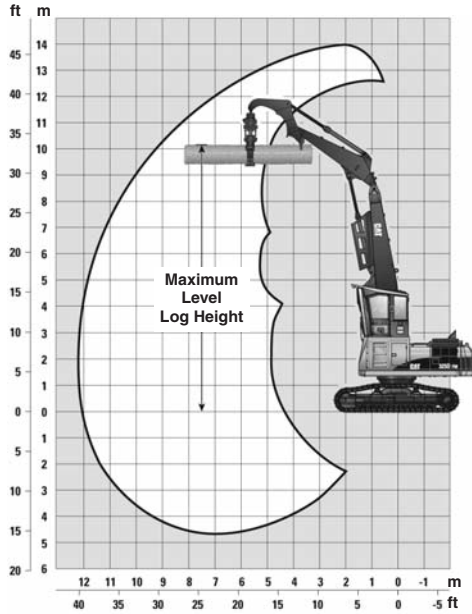

**General Forestry  
HW U/C, 5.9 m (19'4") Boom  
with 2.95S Stick**

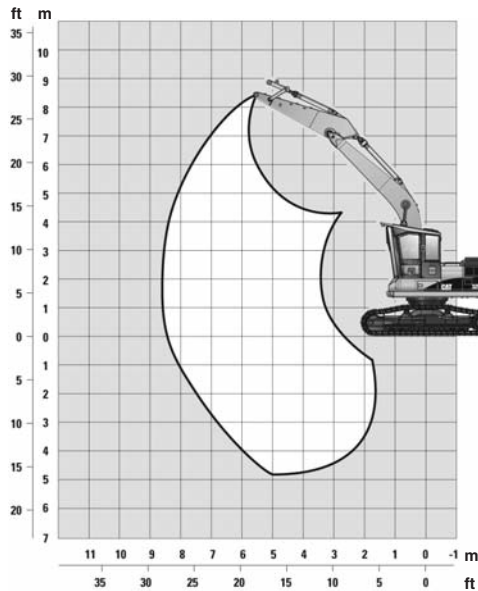

**Heel Boom  
Under/Under**

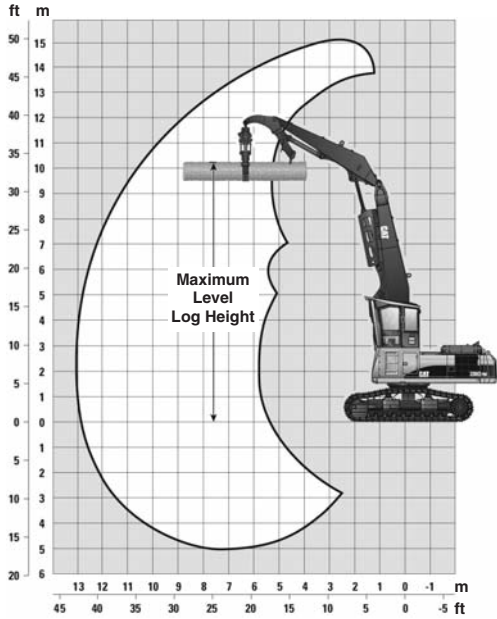

**Heel Boom  
Over/Under**

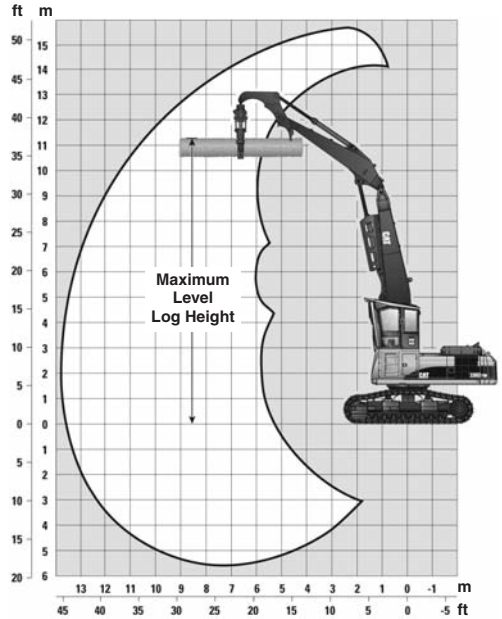

**General Forestry  
HD LC U/C, 6.5 m (21'2") Reach Boom  
with 3.9 m (12'9") Reach Stick**

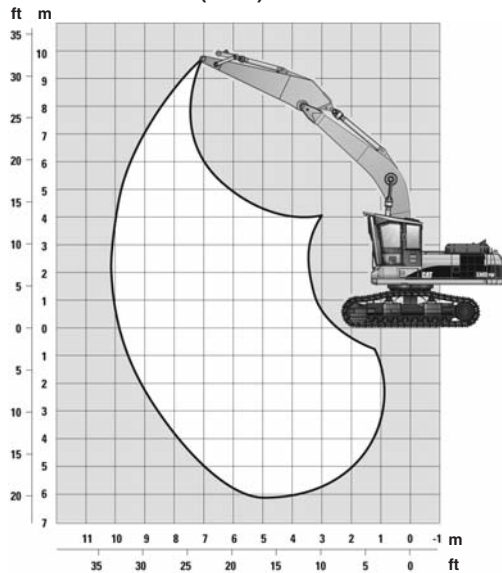

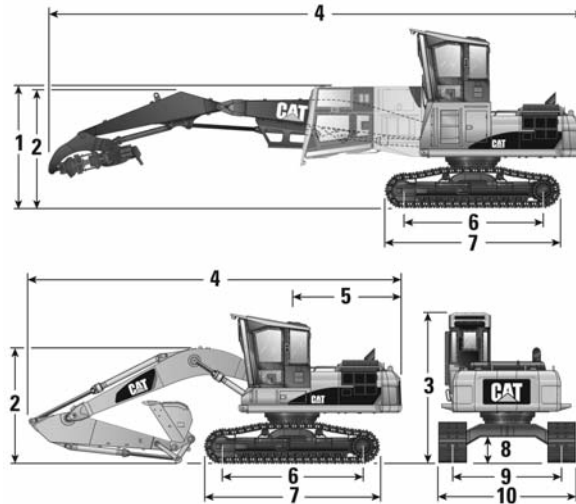

**320D FM General Forestry**

HW

HD/LC

	HW		HD/LC	
<b>1</b> Shipping height (All risers with cab tilted)	3185 mm	10'5"	3000 mm	9'10"
<b>2</b> Boom height	3060 mm	10'0"	3040 mm	10'0"
<b>3</b> Overall height	4657 mm	15'3"	3713 mm	12'2"
<b>4</b> Shipping length	9410 mm	30'10"	9460 mm	31'0"
<b>5</b> Tail swing radius	2774 mm	9'1"	2774 mm	9'1"
<b>6</b> Length to center of rollers	3715 mm	12'2"	3650 mm	12'0"
<b>7</b> Track length	4555 mm	14'11"	4480 mm	14'8"
<b>8</b> Ground clearance	650 mm	2'2"	475 mm	1'7"
<b>9</b> Track gauge	2590 mm	8'6"	2380 mm	7'10"
<b>10</b> Transport width with 700 mm (27.5") shoes (DG)	3290 mm	10'10"	3080 mm	10'1"

**320D FM Log Loaders**

Under/Under

	Under/Under	
<b>1</b> Shipping height (All risers with cab tilted)	3185 mm	10'5"
<b>2</b> Boom height	2980 mm	9'9"
<b>3</b> Overall height	4657 mm	15'3"
<b>4</b> Shipping length	13 620 mm	44'8"
<b>5</b> Tail swing radius	2774 mm	9'1"
<b>6</b> Length to center of rollers	3715 mm	12'2"
<b>7</b> Track length	4555 mm	14'11"
<b>8</b> Ground clearance	650 mm	2'2"
<b>9</b> Track gauge	2590 mm	8'6"
<b>10</b> Transport width with 700 mm (27.5") shoes (DG)	3290 mm	10'10"

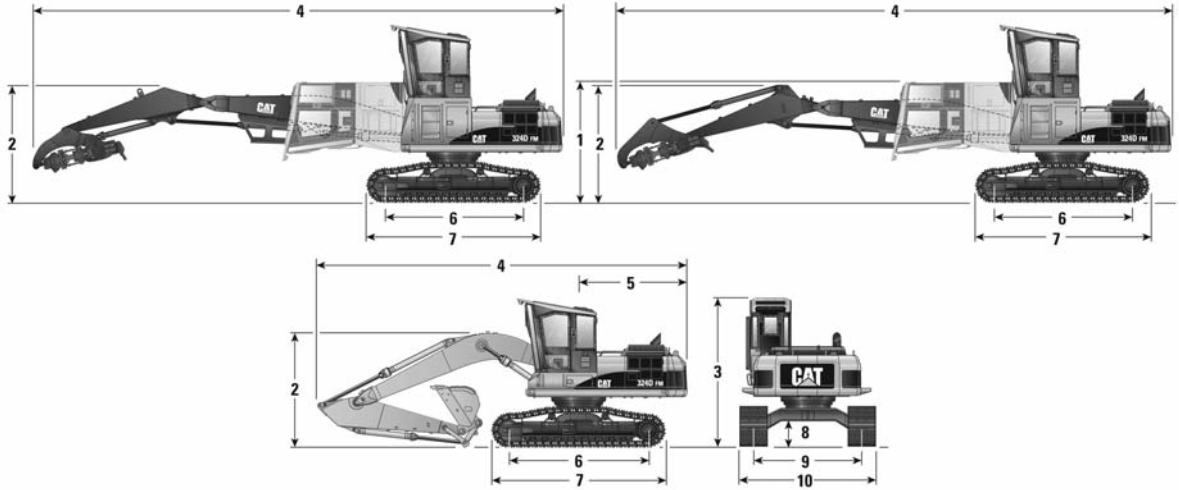

**324D FM General Forestry**

**HW GF**

<b>1</b> Shipping height (All risers with cab tilted)	3310 mm	<b>10'10"</b>
<b>2</b> Boom height	3170 mm	<b>10'5"</b>
<b>3</b> Overall height	4020 mm	<b>13'2"</b>
<b>4</b> Shipping length	9880 mm	<b>32'5"</b>
<b>5</b> Tail swing radius	2940 mm	<b>9'8"</b>
<b>6</b> Length to center of rollers	3780 mm	<b>12'5"</b>
<b>7</b> Track length	4670 mm	<b>15'4"</b>
<b>8</b> Ground clearance	710 mm	<b>2'4"</b>
<b>9</b> Track gauge	2920 mm	<b>9'7"</b>
<b>10</b> Transport width with 700 mm (27.5") shoes (DG)	3620 mm	<b>11'11"</b>

**324D FM Log Loaders**

**Under/Under**

**Over/Under**

<b>1</b> Shipping height (All risers with cab tilted)	3310 mm	<b>10'10"</b>	3310 mm	<b>10'10"</b>
<b>2</b> Boom height	2780 mm	<b>9'1"</b>	2760 mm	<b>9'1"</b>
<b>3</b> Overall height	4790 mm	<b>15'9"</b>	4790 mm	<b>15'9"</b>
<b>4</b> Shipping length	14 080 mm	<b>46'2"</b>	14 990 mm	<b>49'2"</b>
<b>5</b> Tail swing radius	2940 mm	<b>9'8"</b>	2940 mm	<b>9'8"</b>
<b>6</b> Length to center of rollers	3780 mm	<b>12'5"</b>	3780 mm	<b>12'5"</b>
<b>7</b> Track length	4670 mm	<b>15'4"</b>	4670 mm	<b>15'4"</b>
<b>8</b> Ground clearance	710 mm	<b>2'4"</b>	710 mm	<b>2'4"</b>
<b>9</b> Track gauge	2920 mm	<b>9'7"</b>	2920 mm	<b>9'7"</b>
<b>10</b> Transport width with 700 mm (27.5") shoes (DG)	3620 mm	<b>11'11"</b>	3620 mm	<b>11'11"</b>

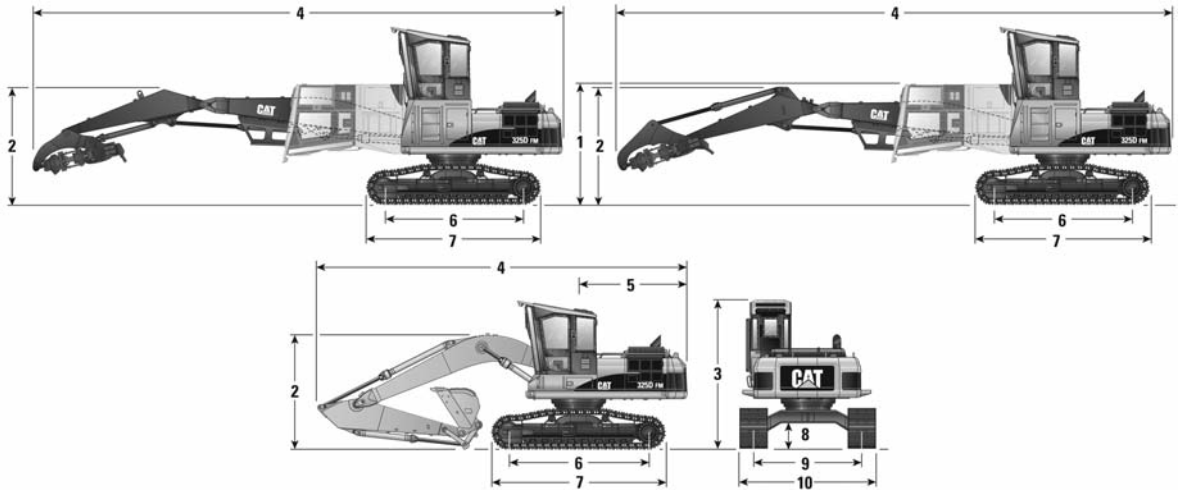

**325D FM General Forestry**

HW GF

1 Shipping height (All risers with cab tilted)	3340 mm	11'0"
2 Boom height	3310 mm	10'10"
3 Overall height	4060 mm	13'4"
4 Shipping length	10 260 mm	33'8"
5 Tail swing radius	3020 mm	9'11"
6 Length to center of rollers	4050 mm	13'4"
7 Track length	4970 mm	16'4"
8 Ground clearance	740 mm	2'5"
9 Track gauge	2920 mm	9'7"
10 Transport width with 700 mm (27.5") shoes (DG)	3620 mm	11'11"

**325D FM Log Loaders**

Under/Under

Over/Under

	Under/Under		Over/Under	
1 Shipping height (All risers with cab tilted)	3340 mm	10'10"	3340 mm	10'10"
2 Boom height	2760 mm	9'1"	2740 mm	9'0"
3 Overall height	4820 mm	15'10"	4820 mm	15'10"
4 Shipping length	14 840 mm	48'8"	15 720 mm	51'7"
5 Tail swing radius	3020 mm	9'11"	3020 mm	9'11"
6 Length to center of rollers	4050 mm	13'4"	4050 mm	13'4"
7 Track length	4970 mm	16'4"	4970 mm	16'4"
8 Ground clearance	740 mm	2'5"	740 mm	2'5"
9 Track gauge	2920 mm	9'7"	2920 mm	9'7"
10 Transport width with 700 mm (27.5") shoes (DG)	3620 mm	11'11"	3620 mm	11'11"

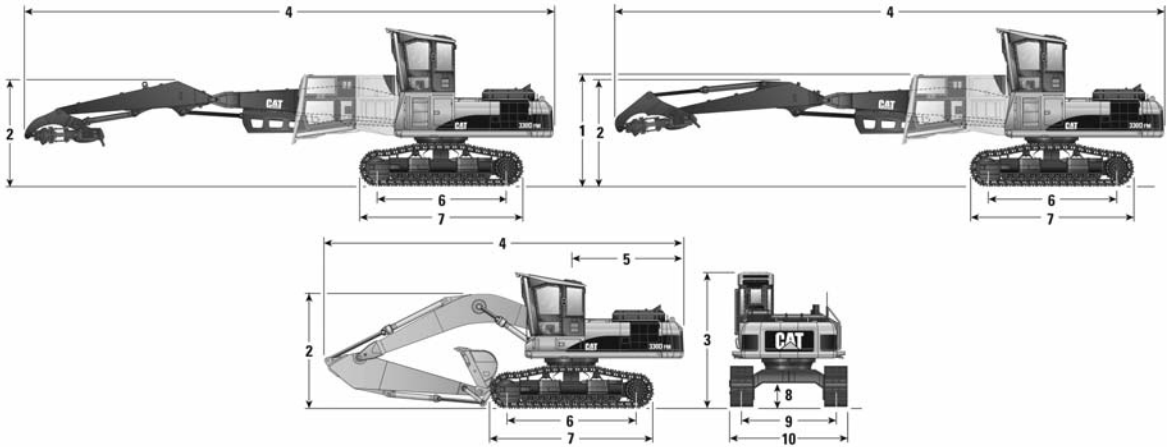

**330D FM General Forestry**

**HD GF**

<b>1</b> Shipping height (All risers with cab tilted)	3470 mm	<b>11'5"</b>
<b>2</b> Boom height	3780 mm	<b>12'5"</b>
<b>3</b> Overall height	4180 mm	<b>13'9"</b>
<b>4</b> Shipping length	11 150 mm	<b>36'7"</b>
<b>5</b> Tail swing radius	3490 mm	<b>11'5"</b>
<b>6</b> Length to center of rollers	4020 mm	<b>13'2"</b>
<b>7</b> Track length	5060 mm	<b>16'7"</b>
<b>8</b> Ground clearance	760 mm	<b>2'6"</b>
<b>9</b> Track gauge	2920 mm	<b>9'7"</b>
<b>10</b> Transport width with 700 mm (27.5") shoes (DG)	3650 mm	<b>11'11"</b>

**330D FM Log Loaders**

**Under/Under**

**Over/Under**

	<b>Under/Under</b>		<b>Over/Under</b>	
<b>1</b> Shipping height (All risers with cab tilted)	3470 mm	<b>11'5"</b>	3470 mm	<b>11'5"</b>
<b>2</b> Boom height	3080 mm	<b>10'1"</b>	3030 mm	<b>10'1"</b>
<b>3</b> Overall height	4950 mm	<b>16'3"</b>	4950 mm	<b>16'3"</b>
<b>4</b> Shipping length	16 630 mm	<b>54'7"</b>	17 320 mm	<b>56'10"</b>
<b>5</b> Tail swing radius	3490 mm	<b>11'5"</b>	3490 mm	<b>11'5"</b>
<b>6</b> Length to center of rollers	4020 mm	<b>13'2"</b>	4020 mm	<b>13'2"</b>
<b>7</b> Track length	5060 mm	<b>16'7"</b>	5060 mm	<b>16'7"</b>
<b>8</b> Ground clearance	760 mm	<b>2'6"</b>	760 mm	<b>2'6"</b>
<b>9</b> Track gauge	2920 mm	<b>9'7"</b>	2920 mm	<b>9'7"</b>
<b>10</b> Transport width with 700 mm (27.5") shoes (DG)	3650 mm	<b>11'11"</b>	3650 mm	<b>11'11"</b>

**324D FM LGP**  
 (Low Ground Pressure)

<b>MODEL</b>		
Rated Power	140 kW	<b>188 hp</b>
Operating Weight (without attachment)	32 886 kg	<b>72,500 lb</b>
Engine Model	<b>C7 ACERT</b>	
Swing Torque	73.4 kN-m	<b>54,147 lb-ft</b>
Drawbar Pull	259 kN	<b>58,226 lb</b>
Maximum Reach	10.3 m	<b>34'0"</b>
Ground Clearance	787 mm	<b>2'6"</b>



**519/529/559B/569/579 Features:**

- **Advanced boom design technology** built tough with welded high-strength steel.
- **Booms** are engineered to withstand high production pull-through delimiting and loading.
- **Boom reach** ranges from 8.2 m (27 ft) on the 519 up to 10.9 m (36 ft) on the 579.
- **Smooth and responsive joystick controls.**
- **Swing torque ratings** up to nearly 108 kN·m (80,000 ft·lb), combined with swing speeds up to 11 RPM.

- **Continuous rotation grapples** are constructed of wear resistant, high tensile steel with heavy-duty rotators designed for strenuous pull-through delimiting applications.
- **Heavy-duty sub-frames** are engineered for high reliability and stability.
- **Heavy duty off road axles** provide trouble free operation in the harsh woods environment.
- **Quiet, comfortable cabs** with excellent visibility.

Loaders offered with a factory matched performance package — The “DS” package is a complete factory installed timber merchandising system consisting of a knuckleboom loader and grapple, trailer with trailer mounted delimeter and ground saw slasher.

<b>MODEL</b>	<b>519</b>		<b>529</b>		<b>559B</b>	
Gross Power	116.3 kW	<b>156 hp</b>	116.3 kW	<b>156 hp</b>	124.5 kW	<b>167 hp</b>
Engine	<b>C6.6</b>		<b>C6.6</b>		<b>C6.6</b>	
Engine RPM	<b>2200</b>		<b>2200</b>		<b>1800</b>	
Operating Weight (with standard boom, less options, carrier & grapple)	8663 kg	<b>19,099 lb</b>	12 655 kg	<b>27,900 lb</b>	14 605 kg	<b>32,200 lb</b>
Hydraulic System:						
System Pressure	15 513 kPa	<b>2250 psi</b>	18 960 kPa	<b>2750 psi</b>	24 131 kPa	<b>3500 psi</b>
Swing Pressure	16 547 kPa	<b>2400 psi</b>	18 271 kPa	<b>2650 psi</b>	21 374 kPa	<b>3100 psi</b>
Swing Speed	<b>8 RPM</b>		<b>8 RPM</b>		<b>11 RPM</b>	
Capacities:						
Fuel Capacity	268.8 L	<b>71 U.S. gal</b>	276.3 L	<b>73 U.S. gal</b>	378.5 L	<b>100 U.S. gal</b>
Hydraulic Capacity	132.5 L	<b>35 U.S. gal</b>	295.3 L	<b>78 U.S. gal</b>	302.8 L	<b>80 U.S. gal</b>
Counterweight	498.0 kg	<b>1100 lb</b>	1496.8 kg	<b>3300 lb</b>	635 kg	<b>1400 lb</b>
Tailswing (with counterweight)	259 cm	<b>102"</b>	248.9 cm	<b>98"</b>	252.7 cm	<b>99.5"</b>
Knuckleboom Length	8.2 m	<b>27'0"</b>	8.8 m	<b>29'0"</b>	9.7 m	<b>32'0"</b>

<b>MODEL</b>	<b>569</b>		<b>579</b>	
Gross Power	129.8 kW	<b>173 hp</b>	129.8 kW	<b>173 hp</b>
Engine	<b>C6.6</b>		<b>C6.6</b>	
Engine RPM	<b>2200</b>		<b>2200</b>	
Operating Weight (with standard boom, less options, carrier & grapple)	15 422 kg	<b>34,000 lb</b>	15 422 kg	<b>34,000 lb</b>
Hydraulic System:				
System Pressure	17 236 kPa	<b>2500 psi</b>	24 131 kPa	<b>3500 psi</b>
Swing Pressure	17 236 kPa	<b>2500 psi</b>	24 131 kPa	<b>3500 psi</b>
Swing Speed	<b>7 RPM</b>		<b>9 RPM</b>	
Capacities:				
Fuel Capacity	336.9 L	<b>89 U.S. gal</b>	336.9 L	<b>89 U.S. gal</b>
Hydraulic Capacity	246 L	<b>65 U.S. gal</b>	246 L	<b>65 U.S. gal</b>
Counterweight	1392.5 kg	<b>3070 lb</b>	1392.5 kg	<b>3070 lb</b>
Tailswing (with counterweight)	248.9 cm	<b>98"</b>	248.9 cm	<b>98"</b>
Knuckleboom Length	9.9 m	<b>32'6"</b>	9.9 m	<b>32'6"</b>

Basic Dimensions for 519, 529 and 559B

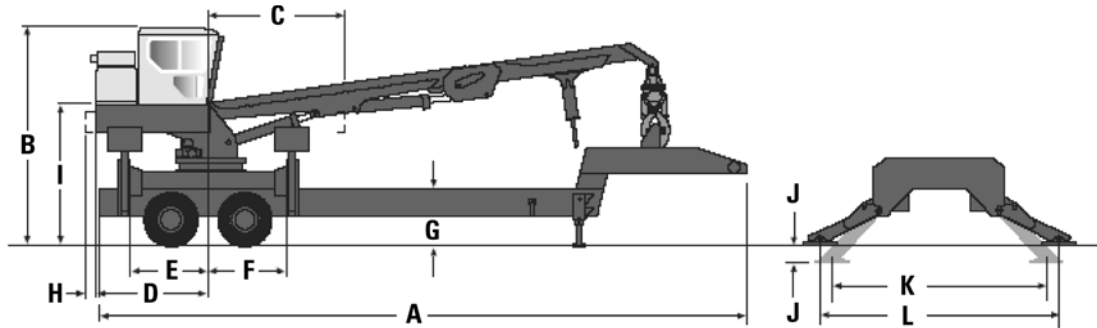

Basic Dimensions for 569 and 579

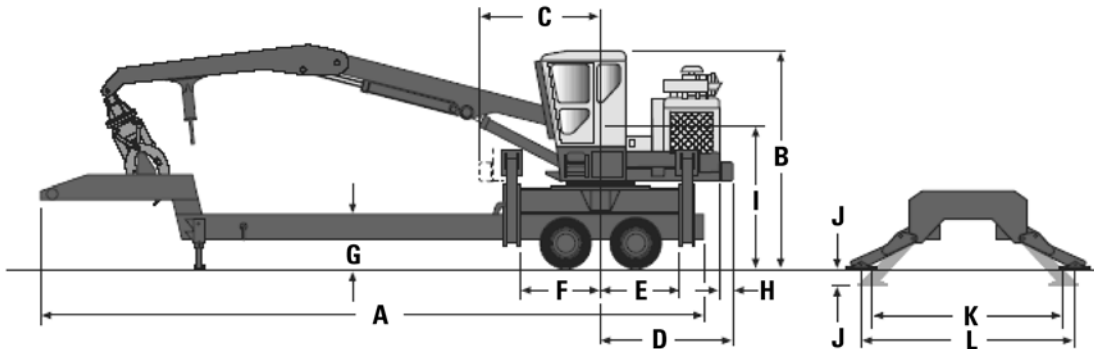

MODEL	519		529		559B		569		579	
<b>A</b>	1127.8 cm	<b>444.00"</b>	1219.2 cm	<b>480.00"</b>	1219.2 cm	<b>480.00"</b>	1219.2 cm	<b>480.00"</b>	1219.2 cm	<b>480.00"</b>
<b>B</b>	401.3 cm	<b>158.00"</b>	404.5 cm	<b>159.25"</b>	401.6 cm	<b>158.10"</b>	398.8 cm	<b>157.00"</b>	398.8 cm	<b>157.00"</b>
<b>C*</b>	256.5 cm	<b>101.00"</b>	248.9 cm	<b>98.00"</b>	252.7 cm	<b>99.50"</b>	248.9 cm	<b>98.00"</b>	248.9 cm	<b>98.00"</b>
<b>D</b>	228.6 cm	<b>90.00"</b>	232.0 cm	<b>91.34"</b>	227.8 cm	<b>89.70"</b>	238.1 cm	<b>93.75"</b>	238.1 cm	<b>93.75"</b>
<b>E</b>	137.2 cm	<b>54.00"</b>	152.4 cm	<b>60.00"</b>	152.4 cm	<b>60.00"</b>	152.4 cm	<b>60.00"</b>	152.4 cm	<b>60.00"</b>
<b>F</b>	137.2 cm	<b>54.00"</b>	152.4 cm	<b>60.00"</b>	152.4 cm	<b>60.00"</b>	152.4 cm	<b>60.00"</b>	152.4 cm	<b>60.00"</b>
<b>G</b>	99.1 cm	<b>39.00"</b>	99.1 cm	<b>39.00"</b>	99.1 cm	<b>39.00"</b>	99.1 cm	<b>39.00"</b>	99.1 cm	<b>39.00"</b>
<b>H**</b>	10.2 cm	<b>4.00"</b>	24.1 cm	<b>9.50"</b>	7.6 cm	<b>3.00"</b>	27.3 cm	<b>10.75"</b>	27.3 cm	<b>10.75"</b>
<b>I</b>	238.8 cm	<b>94.00"</b>	246.4 cm	<b>97.00"</b>	246.4 cm	<b>97.00"</b>	269.2 cm	<b>106.00"</b>	269.2 cm	<b>106.00"</b>
<b>J</b>	35.6 cm	<b>14.00"</b>	36.0 cm	<b>14.18"</b>	41.9 cm	<b>16.50"</b>	39.4 cm	<b>15.50"</b>	39.4 cm	<b>15.50"</b>
<b>K</b>	416.6 cm	<b>164.00"</b>	392.0 cm	<b>154.35"</b>	425.4 cm	<b>167.47"</b>	454.7 cm	<b>179.00"</b>	454.7 cm	<b>179.00"</b>
<b>L</b>	457.2 cm	<b>180.00"</b>	447.0 cm	<b>176.00"</b>	495.3 cm	<b>195.70"</b>	495.3 cm	<b>195.00"</b>	495.3 cm	<b>195.00"</b>

\*Maximum tailswing.

\*\*Add for counterweight.

# Forest Products Trailer Mount Knuckleboom Loaders

## Lift and Range Diagram ● 519 Knuckleboom Loader

**519 Knuckleboom Loader  
8.2 m (27'0") Boom**

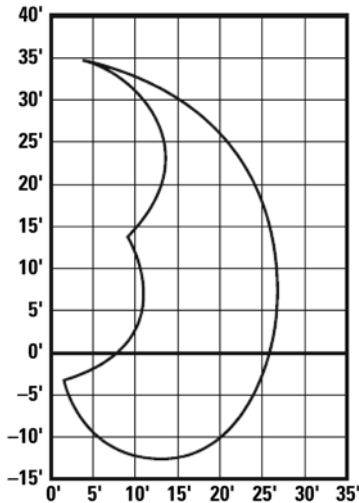

**NOTES:**

Do not attempt to lift or hold any load that is greater than the rated values over the end or side. The weight of the grapple and all lifting accessories must be deducted from lift capacities shown.

1. The over end capacities and over side capacities do not exceed 87% of hydraulic limited capacity or 75% of stability limited capacity.  
– Stability limited capacities are indicated with an asterisk (\*).
2. The lift point is located at the grapple knuckle pin.
3. Lift capacities are based on the machine standing on firm, uniform supporting surface. User must make allowances for job site conditions.
4. Operator should be fully acquainted with the Operator's Manual and all safety instructions furnished by Caterpillar Inc. prior to operating the machine.
5. Lift capacities are in compliance with SAE J2417, "Lift Capacity Calculation Method — Knuckleboom Log Loaders and Certain Forestry Equipment."

	3 m/10'0"		4.6 m/15'0"		6.1 m/20'0"		7.6 m/25'0"		Maximum Reach		
	kg	lb	kg	lb	kg	lb	kg	lb	kg	lb	
9.1 m (30'0")			4574.6 3979.9 3979.9	<b>10,085</b> <b>8,774</b> <b>8,774</b>							100% Hydraulics Over End Over Side
7.6 m (25'0")			5208.7 4531.5 4531.5	<b>11,483</b> <b>9,990</b> <b>9,990</b>	4076.5 3543.1 3543.1	<b>8,978</b> <b>7,811</b> <b>7,811</b>					100% Hydraulics Over End Over Side
6.1 m (20'0")			5246.8 4564.6 4564.6	<b>11,567</b> <b>10,063</b> <b>10,063</b>	4611.3 4011.6 4011.6	<b>10,166</b> <b>8,844</b> <b>8,844</b>					100% Hydraulics Over End Over Side
4.6 m (15'0")			5673.2 4935.6 4935.6	<b>12,507</b> <b>10,881</b> <b>10,881</b>	4742.4 4125.9 4125.9	<b>10,455</b> <b>9,096</b> <b>9,096</b>	3954.5 3440.5 3215.1	<b>8,718</b> <b>7,585</b> <b>7,088*</b>	1850.2 1609.8 1609.8	<b>4,079</b> <b>3,549</b> <b>3,549</b>	100% Hydraulics Over End Over Side
3.0 m (10'0")			6305.5 5485.8 5485.8	<b>13,901</b> <b>12,094</b> <b>12,094</b>	5545.7 4824.9 4582.7	<b>12,226</b> <b>10,637</b> <b>10,103*</b>	3920.5 3410.6 3188.3	<b>8,643</b> <b>7,519</b> <b>7,029*</b>	1776.5 1545.9 1545.9	<b>3,917</b> <b>3,408</b> <b>3,408</b>	100% Hydraulics Over End Over Side
1.5 m (5'0")			8720.0 7586.5 7369.7	<b>19,224*</b> <b>16,725*</b> <b>16,247*</b>	6520.5 5672.7 4106.9	<b>14,375</b> <b>12,506</b> <b>9,054*</b>	4068.3 3539.4 3152.5	<b>8,969</b> <b>7,803</b> <b>6,950*</b>	1771.3 1540.9 1540.9	<b>3,905</b> <b>3,397</b> <b>3,397</b>	100% Hydraulics Over End Over Side
0 m (0'0")	4373.2 3804.8 3804.8	<b>9,641</b> <b>8,388</b> <b>8,388</b>	8341.2 7256.7 7186.4	<b>18,389*</b> <b>15,998*</b> <b>15,843*</b>	6061.9 5274.0 4395.4	<b>13,364</b> <b>11,627</b> <b>9,690*</b>	3553.0 3091.3 3091.3	<b>7,833</b> <b>6,815</b> <b>6,815</b>			100% Hydraulics Over End Over Side
-1.5 m (-5'0")	6371.3 5543.0 5543.0	<b>14,046</b> <b>12,220</b> <b>12,220</b>	6789.5 5906.8 5906.8	<b>14,968</b> <b>13,022</b> <b>13,022</b>	4688.8 4079.2 4079.2	<b>10,337</b> <b>8,993</b> <b>8,993</b>					100% Hydraulics Over End Over Side
-3.0 m (-10'0")	4980.1 4332.8 4332.8	<b>10,979</b> <b>9,552</b> <b>9,552</b>	3743.6 3256.8 3256.8	<b>8,253</b> <b>7,180</b> <b>7,180</b>	1100.0 957.1 957.1	<b>2,425</b> <b>2,110</b> <b>2,110</b>					100% Hydraulics Over End Over Side

# Lift and Range Diagram ● 529 Knuckleboom Loader

## Forest Products Trailer Mount Knuckleboom Loaders

### 529 Knuckleboom Loader 8.8 m (29'0") Boom

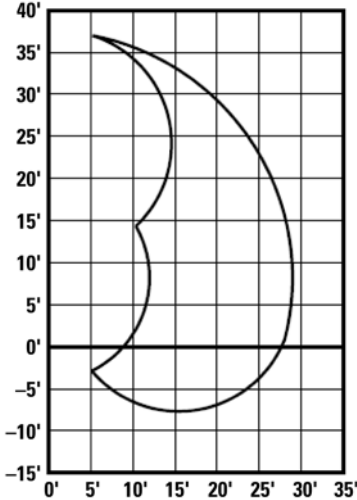

#### NOTES:

Do not attempt to lift or hold any load that is greater than the rated values over the end or side. The weight of the grapple and all lifting accessories must be deducted from lift capacities shown.

- The over end capacities and over side capacities do not exceed 87% of hydraulic limited capacity or 75% of stability limited capacity.  
– Stability limited capacities are indicated with an asterisk (\*).
- The lift point is located at the grapple knuckle pin.
- Lift capacities are based on the machine standing on firm, uniform supporting surface. User must make allowances for job site conditions.
- Operator should be fully acquainted with the Operator's Manual and all safety instructions furnished by Caterpillar Inc. prior to operating the machine.
- Lift capacities are in compliance with SAE J2417, "Lift Capacity Calculation Method — Knuckleboom Log Loaders and Certain Forestry Equipment."

	3 m/10'0"		4.6 m/15'0"		6.1 m/20'0"		7.6 m/25'0"		Maximum Reach		
	kg	lb	kg	lb	kg	lb	kg	lb	kg	lb	
9.1 m (30'0")			5591.9 4864.8 4864.8	<b>12,328</b> <b>10,725</b> <b>10,725</b>							100% Hydraulics Over End Over Side
7.6 m (25'0")			5854.1 5093.1 5093.1	<b>12,906</b> <b>11,228</b> <b>11,228</b>	5136.6 4468.8 4468.8	<b>11,324</b> <b>9,852</b> <b>9,852</b>					100% Hydraulics Over End Over Side
6.1 m (20'0")			5896.7 5130.2 5130.2	<b>13,000</b> <b>11,310</b> <b>11,310</b>	5481.7 4769.2 4769.2	<b>12,085</b> <b>10,514</b> <b>10,514</b>	4159.5 3618.8 3618.8	<b>9,170</b> <b>7,978</b> <b>7,978</b>			100% Hydraulics Over End Over Side
4.6 m (15'0")			6384.8 5554.7 5554.7	<b>14,076</b> <b>12,246</b> <b>12,246</b>	5641.8 4908.4 4908.4	<b>12,438</b> <b>10,821</b> <b>10,821</b>	4650.8 4046.1 4046.1	<b>10,253</b> <b>8,920</b> <b>8,920</b>	2379.5 2070.2 2070.2	<b>5,246</b> <b>4,564</b> <b>4,564</b>	100% Hydraulics Over End Over Side
3.0 m (10'0")			7557.4 6574.8 6574.8	<b>16,661</b> <b>14,495</b> <b>14,495</b>	6542.2 5691.7 5691.7	<b>14,423</b> <b>12,548</b> <b>12,548</b>	5072.6 4413.1 4413.1	<b>11,183</b> <b>9,729</b> <b>9,729</b>	2344.2 2039.4 2039.4	<b>5,168</b> <b>4,496</b> <b>4,496</b>	100% Hydraulics Over End Over Side
1.5 m (5'0")			8857.8 7706.2 7706.2	<b>19,528</b> <b>16,989</b> <b>16,989</b>	6573.1 5718.5 5718.5	<b>14,491</b> <b>12,607</b> <b>12,607</b>	4963.7 4318.2 4318.2	<b>10,943</b> <b>9,520</b> <b>9,520</b>	2355.9 2049.8 2049.8	<b>5,194</b> <b>4,519</b> <b>4,519</b>	100% Hydraulics Over End Over Side
0 m (0'0")	6924.5 6024.2 6024.2	<b>15,266</b> <b>13,281</b> <b>13,281</b>	8425.6 7330.2 7330.2	<b>18,575</b> <b>16,160</b> <b>16,160</b>	6101.3 5308.1 5308.1	<b>13,451</b> <b>11,702</b> <b>11,702</b>	4259.8 3705.9 3705.9	<b>9,391</b> <b>8,170</b> <b>8,170</b>			100% Hydraulics Over End Over Side
-1.5 m (-5'0")	7980.1 6942.8 6942.8	<b>17,593</b> <b>15,306</b> <b>15,306</b>	6807.2 5922.2 5922.2	<b>15,007</b> <b>13,056</b> <b>13,056</b>	4782.3 4160.4 4160.4	<b>10,543</b> <b>9,172</b> <b>9,172</b>					100% Hydraulics Over End Over Side

# Forest Products Trailer Mount Knuckleboom Loaders

## Lift and Range Diagram ● 559B Knuckleboom Loader

### 559B Knuckleboom Loader 9.8 m (32'0") Boom

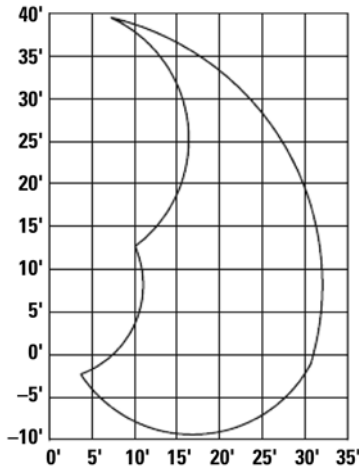

#### NOTES:

Do not attempt to lift or hold any load that is greater than the rated values over the end or side. The weight of the grapple and all lifting accessories must be deducted from lift capacities shown.

1. The over end capacities and over side capacities do not exceed 87% of hydraulic limited capacity or 75% of stability limited capacity.  
– Stability limited capacities are indicated with an asterisk (\*).
2. The lift point is located at the grapple knuckle pin.
3. Lift capacities are based on the machine standing on firm, uniform supporting surface. User must make allowances for job site conditions.
4. Operator should be fully acquainted with the Operator's Manual and all safety instructions furnished by Caterpillar Inc. prior to operating the machine.
5. Lift capacities are in compliance with SAE J2417, "Lift Capacity Calculation Method — Knuckleboom Log Loaders and Certain Forestry Equipment."

	3 m/10'0"		4.6 m/15'0"		6.1 m/20'0"		7.6 m/25'0"		9.1 m/30'0"		Maximum Reach		
	kg	lb	kg	lb	kg	lb	kg	lb	kg	lb	kg	lb	
10.6 m (35'0")			5687.1 4947.8 4947.8	12,538 10,908 10,908									100% Hydraulics Over End Over Side
9.1 m (30'0")					5398.7 4696.9 4696.9	11,902 10,355 10,355							100% Hydraulics Over End Over Side
7.6 m (25'0")					5630.9 4898.8 4898.8	12,414 10,800 10,800	4732.4 4117.3 4117.3	10,433 9,077 9,077					100% Hydraulics Over End Over Side
6.1 m (20'0")					5751.1 5003.6 5003.6	12,679 11,031 11,031	5133.3 4466.1 4466.1	11,317 9,846 9,846					100% Hydraulics Over End Over Side
4.6 m (15'0")			7265.2 6320.8 6320.8	16,017 13,935 13,935	6594.8 5737.5 5737.5	14,539 12,649 12,649	5594.2 4867.1 4867.1	12,333 10,730 10,730	4182.6 3638.7 3631.9	9,221 8,022 8,007*	2665.8 2319.2 2319.2	5,877 5,113 5,113	100% Hydraulics Over End Over Side
3.0 m (10'0")			9105.9 7921.9 7921.9	20,075 17,465 17,465	7195.8 6260.5 6260.5	15,864 13,802 13,802	5946.1 5173.6 5173.6	13,109 11,405 10,851*	4455.2 3875.9 3582.2	9,822 8,522 7,897	2691.2 2341.4 2341.4	5,933 5,162 5,162	100% Hydraulics Over End Over Side
1.5 m (5'0")			10 155.1 8800.2 8800.2	22,300 19,401 19,401	7591.8 6604.8 6604.8	16,737 14,561 14,561	6015.5 5233.5 4776.4	13,262 11,538 10,530*	4253.4 3700.5 3526.7	9,377 8,158 7,775*	2797.8 2433.9 2433.9	6,168 5,366 5,366	100% Hydraulics Over End Over Side
0 m (0'0")	8249.5 7177.2 7177.2	18,187 15,823 15,823	10 288.4 8950.8 8950.8	22,682 19,733 19,733	7553.7 6571.7 6571.7	16,653 14,488 14,488	5758.4 5009.9 4667.5	12,695 11,045 10,290*	3705.9 3224.2 3224.2	8,170 7,108 7,108			100% Hydraulics Over End Over Side
-1.5 m (-5'0")	8217.3 7149.1 7149.1	18,116 15,761 15,761	9281.9 8075.4 8075.4	20,463 17,803 17,803	6782.6 5900.8 5900.8	14,953 13,009 13,009	4870.2 4237.0 4237.0	10,737 9,341 9,341					100% Hydraulics Over End Over Side

# Lift and Range Diagram ● 569 Knuckleboom Loader

## Forest Products Trailer Mount Knuckleboom Loaders

### 569 Knuckleboom Loader 9.9 m (32'6") Boom

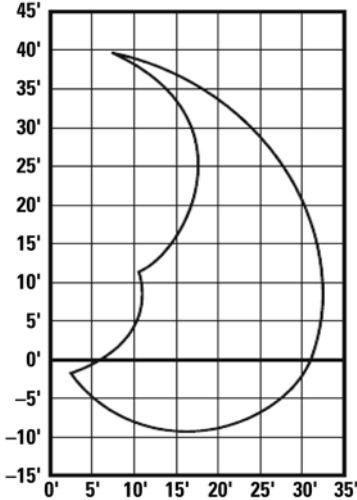

#### NOTES:

Do not attempt to lift or hold any load that is greater than the rated values over the end or side. The weight of the grapple and all lifting accessories must be deducted from lift capacities shown.

1. The over end capacities and over side capacities do not exceed 87% of hydraulic limited capacity or 75% of stability limited capacity.  
– Stability limited capacities are indicated with an asterisk (\*).
2. The lift point is located at the grapple knuckle pin.
3. Lift capacities are based on the machine standing on firm, uniform supporting surface. User must make allowances for job site conditions.
4. Operator should be fully acquainted with the Operator's Manual and all safety instructions furnished by Caterpillar Inc. prior to operating the machine.
5. Lift capacities are in compliance with SAE J2417, "Lift Capacity Calculation Method — Knuckleboom Log Loaders and Certain Forestry Equipment."

	3 m/10'0"		4.6 m/15'0"		6.1 m/20'0"		7.6 m/25'0"		9.1 m/30'0"		Maximum Reach		
	kg	lb	kg	lb	kg	lb	kg	lb	kg	lb	kg	lb	
10.6 m (35'0")			5286.7 4599.5 4599.5	11,655 10,140 10,140									100% Hydraulics Over End Over Side
9.1 m (30'0")					4972.9 4326.4 4326.4	10,963 9,538 9,538							100% Hydraulics Over End Over Side
7.6 m (25'0")					5758.4 5010.0 5010.0	12,695 11,045 11,045	4410.8 3937.4 3937.4	9,724 8,460 8,460					100% Hydraulics Over End Over Side
6.1 m (20'0")					6363.5 5536.2 5536.2	14,029 12,205 12,205	5428.7 4722.9 4722.9	11,968 10,412 10,412					100% Hydraulics Over End Over Side
4.6 m (15'0")			7299.3 6350.4 6350.4	16,092 14,000 14,000	6877.5 5983.4 5983.4	15,162 13,191 13,191	6073.2 5283.5 5283.5	13,389 11,648 11,648	2767.9 2408.2 2408.2	6,102 5,309 5,309			100% Hydraulics Over End Over Side
3.0 m (10'0")			9814.5 8538.6 8538.6	21,637 18,824 18,824	8452.4 7353.8 7353.8	18,634 16,212 16,212	6934.2 6032.9 6032.9	15,287 13,300 13,300	3974.0 3457.3 3457.3	8,761 7,622 7,622	2324.2 2022.1 2022.1	5,124 4,458 4,458	100% Hydraulics Over End Over Side
1.5 m (5'0")	18 436.1 16 039.3 16 039.3	40,644 35,360 35,360	12 083.4 10 512.6 10 512.6	26,639 23,176 23,176	9112.8 7928.0 7928.0	20,090 17,478 17,478	7295.7 6347.2 6347.2	16,084 13,993 13,993	4668.4 4061.5 4061.5	10,292 8,954 8,954	2366.0 2058.4 2058.4	5,216 4,538 4,538	100% Hydraulics Over End Over Side
0 m (0'0")	10 192.8 8867.9 8867.9	22,471 19,550 19,550	12 622.8 10 981.6 10 981.6	27,828 24,210 24,210	9241.6 8040.1 8040.1	20,374 17,725 17,725	7086.8 6173.5 6173.5	15,644 13,610 13,610	4947.4 4304.2 4304.2	10,907 9,489 9,489	2480.3 2157.8 2157.8	5,468 4,757 4,757	100% Hydraulics Over End Over Side
-1.5 m (-5'0")	9419.5 8194.7 8194.7	20,766 18,066 18,066	11 628.5 10 116.6 10 116.6	25,636 22,303 22,303	8447.8 7349.7 7349.7	18,624 16,203 16,203	6120.4 5324.8 5324.8	13,493 11,739 11,739	4361.8 3794.8 3794.8	9,616 8,366 8,366			100% Hydraulics Over End Over Side

# Forest Products Trailer Mount Knuckleboom Loaders

## Lift and Range Diagram ● 579 Knuckleboom Loader

### 579 Knuckleboom Loader 9.9 m (32'6") Boom

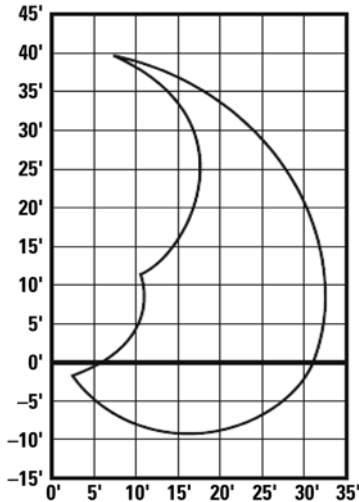

#### NOTES:

Do not attempt to lift or hold any load that is greater than the rated values over the end or side. The weight of the grapple and all lifting accessories must be deducted from lift capacities shown.

- The over end capacities and over side capacities do not exceed 87% of hydraulic limited capacity or 75% of stability limited capacity.  
– Stability limited capacities are indicated with an asterisk (\*).
- The lift point is located at the grapple knuckle pin.
- Lift capacities are based on the machine standing on firm, uniform supporting surface. User must make allowances for job site conditions.
- Operator should be fully acquainted with the Operator's Manual and all safety instructions furnished by Caterpillar Inc. prior to operating the machine.
- Lift capacities are in compliance with SAE J2417, "Lift Capacity Calculation Method — Knuckleboom Log Loaders and Certain Forestry Equipment."

	3 m/10'0"		4.6 m/15'0"		6.1 m/20'0"		7.6 m/25'0"		9.1 m/30'0"		Maximum Reach		
	kg	lb	kg	lb	kg	lb	kg	lb	kg	lb	kg	lb	
10.6 m (35'0")			6514.1 5667.3 5667.3	<b>14,361</b> <b>12,494</b> <b>12,494</b>									100% Hydraulics Over End Over Side
9.1 m (30'0")					6142.2 5343.8 5343.8	<b>13,541</b> <b>11,781</b> <b>11,781</b>							100% Hydraulics Over End Over Side
7.6 m (25'0")					6077.8 5287.6 5287.6	<b>13,399</b> <b>11,657</b> <b>11,657</b>	5470.4 4759.2 4759.2	<b>12,060</b> <b>10,492</b> <b>10,492</b>					100% Hydraulics Over End Over Side
6.1 m (20'0")					6246.1 5434.1 5434.1	<b>13,770</b> <b>11,980</b> <b>11,980</b>	5763.0 5013.6 5013.6	<b>12,705</b> <b>11,053</b> <b>11,053</b>	3497.7 3043.2 3043.2	<b>7,711</b> <b>6,709</b> <b>6,709</b>			100% Hydraulics Over End Over Side
4.6 m (15'0")			7689.4 6689.7 6689.7	<b>16,952</b> <b>14,748</b> <b>14,748</b>	7085.2 6164.0 6164.0	<b>15,620</b> <b>13,589</b> <b>13,589</b>	6041.0 5255.9 5255.9	<b>13,318</b> <b>11,587</b> <b>11,587</b>	4944.0 4306.9 4306.9	<b>10,914</b> <b>9,495</b> <b>9,495</b>	2967.0 2581.4 2581.4	<b>6,541</b> <b>5,691</b> <b>5,691</b>	100% Hydraulics Over End Over Side
3.0 m (10'0")			10 201.0 8874.7 8874.7	<b>22,489</b> <b>19,565</b> <b>19,565</b>	9232.1 8031.9 8031.9	<b>20,353</b> <b>17,707</b> <b>17,707</b>	7230.4 6290.5 6290.5	<b>15,940</b> <b>13,868</b> <b>13,868</b>	5247.7 4565.5 4565.5	<b>11,569</b> <b>10,065</b> <b>10,065</b>	3019.2 2626.8 2626.8	<b>6,656</b> <b>5,791</b> <b>5,791</b>	100% Hydraulics Over End Over Side
1.5 m (5'0")	21 356.8 18 580.4 18 580.4	<b>47,083</b> <b>40,962</b> <b>40,962</b>	14 054.3 12 227.2 12 227.2	<b>30,984</b> <b>26,956</b> <b>26,956</b>	10 646.4 9262.5 9262.5	<b>23,471</b> <b>20,420</b> <b>20,420</b>	8611.6 7452.6 6731.0	<b>18,885</b> <b>16,430</b> <b>14,839*</b>	5083.1 4428.0 4428.0	<b>11,221</b> <b>9,762</b> <b>9,762</b>	3164.3 2752.9 2752.9	<b>6,976</b> <b>6,069</b> <b>6,069</b>	100% Hydraulics Over End Over Side
0 m (0'0")	10 070.8 8761.7 8761.7	<b>22,202</b> <b>19,316</b> <b>19,316</b>	14 724.3 12 810.1 12 810.1	<b>32,461</b> <b>28,241</b> <b>28,241</b>	10 824.7 9417.6 9417.6	<b>23,864</b> <b>20,762</b> <b>20,762</b>	8356.2 7269.8 6630.3	<b>18,422</b> <b>16,027</b> <b>14,617*</b>	4487.0 3903.7 3903.7	<b>9,892</b> <b>8,606</b> <b>8,606</b>			100% Hydraulics Over End Over Side
-1.5 m (-5'0")	9314.2 8103.6 8103.6	<b>20,534</b> <b>17,865</b> <b>17,865</b>	13 622.5 11 851.7 11 851.7	<b>30,032</b> <b>26,128</b> <b>26,128</b>	9940.6 8648.3 8648.3	<b>21,915</b> <b>19,066</b> <b>19,066</b>	7256.7 6313.2 6313.2	<b>15,998</b> <b>13,918</b> <b>13,918</b>					100% Hydraulics Over End Over Side

**519/569 Features:**

- **Heavy-duty boom options** range in length from 8.2 m (27 ft) to 10.90 m (36 ft) for handling a variety of tree lengths.
- **Weatherproof electric service panels** include starters, controls, transformers, circuit breakers and fuse blocks.
- **Electric motors** are rated for severe duty.
- **Resilient Pad Mounting System** includes a set of special rubber isolators on each mounting fastener that absorbs stress in two directions.
- **Hydraulic pilot joystick controls and rocker swing pedal** are ergonomically designed for ease of operation and maximum loader control.

MODEL	519 SM		519 SM/EHC		569 SM		569 SM/EHC	
Electric Power Supply (standard)	<b>460 Volt: 60 Hz</b>		<b>460 Volt: 60 Hz</b>		<b>460 Volt: 60 Hz</b>		<b>460 Volt: 60 Hz</b>	
Electric Power Supply (optional)*	<b>575 Volt: 60 Hz</b>		<b>575 Volt: 60 Hz</b>		<b>575 Volt: 60 Hz</b>		<b>575 Volt: 60 Hz</b>	
Electric Motor @ 1800 RPM	56 kW	<b>75 hp</b>	56 kW	<b>75 hp</b>	74 kW	<b>100 hp</b>	74 kW	<b>100 hp</b>
Operating Weight	7218.9 kg	<b>15,915 lb</b>	6946.7 kg	<b>15,315 lb</b>	8593.3 kg	<b>18,945 lb</b>	8321.1 kg	<b>18,345 lb</b>
Hydraulic System:								
System Pressure	15 168 kPa	<b>2200 psi</b>	15 168 kPa	<b>2200 psi</b>	17 237 kPa	<b>2500 psi</b>	17 237 kPa	<b>2500 psi</b>
Swing Pressure	16 547 kPa	<b>2400 psi</b>	16 547 kPa	<b>2400 psi</b>	17 237 kPa	<b>2500 psi</b>	17 237 kPa	<b>2500 psi</b>
Swing Speed	<b>8 RPM</b>		<b>8 RPM</b>		<b>7 RPM</b>		<b>7 RPM</b>	
Knuckleboom Length (standard)	8.2 m	<b>27'0"</b>	8.2 m	<b>27'0"</b>	9.9 m	<b>32'6"</b>	9.9 m	<b>32'6"</b>
Knuckleboom Length (optional)	9.1 m	<b>30'0"</b>	9.1 m	<b>30'0"</b>	11.0 m	<b>36'0"</b>	11.0 m	<b>36'0"</b>

\*NOTE: Other Electric Power options available by special quote.



# Forest Products Stationary Mount Knuckleboom Loaders

## Dimensions

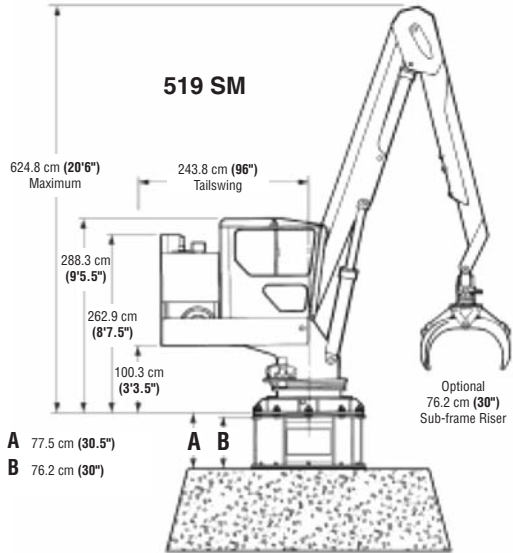

**NOTE:** Overall height dimension to 8.2 m (27'0") boom articulation point is taken with main boom cylinder fully extended. Add 76.2 cm (30") to this dimension for 9.1 m (30'0") knuckleboom.

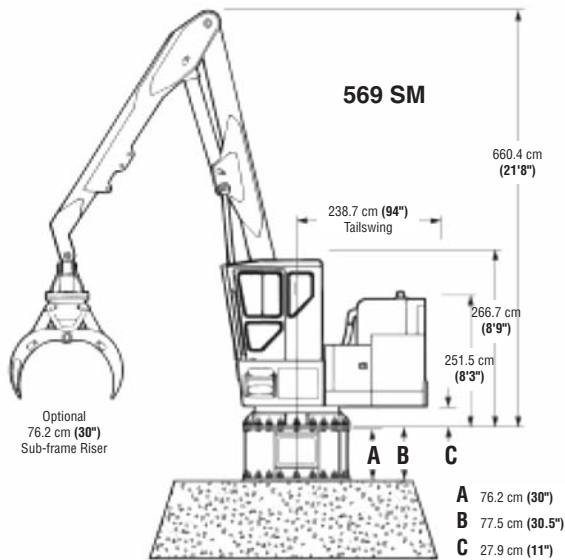

**NOTE:** Overall height dimension to 9.1 m (30'0") boom articulation point is taken with main boom cylinder fully extended. Add 106.9 cm (42") to this dimension for 10.9 m (36'0") knuckleboom.

## Resilient Pad System

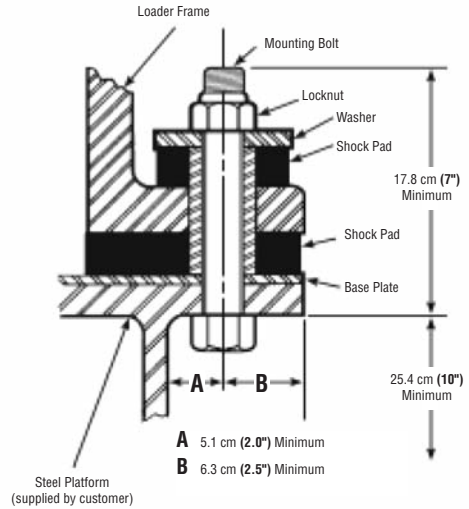

- Operator's cab is not present on EHC models.
- EHC models available with Remote Power Packs.
- Installations on concrete include "J" Bolts in lieu of Mounting Bolt.

Lift and Range Diagram  
 ● 519 SM Knuckleboom Loader  
 ● 519 SM/EHC Knuckleboom Loader

Forest Products  
 Stationary Mount  
 Knuckleboom Loaders

519 SM/519 SM/EHC  
 8.2 m (27'0") Boom

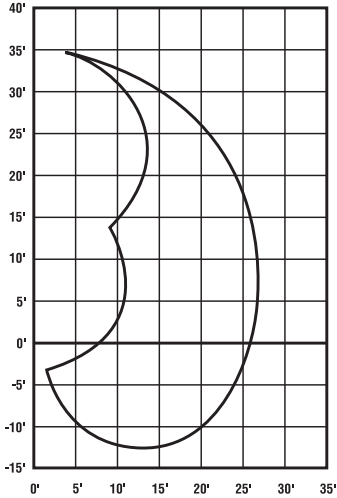

NOTES:

Do not attempt to lift or hold any load that is greater than the rated values over the end or side at their specified lift point and height. The weight of the grapple and all lifting accessories must be deducted from lift capacities shown.

1. All figures shown in these charts represent rated lift capacities.
2. Capacities shown in *italic* are 100% of hydraulic capacity; other capacities shown are 87% of hydraulic capability.
3. The lift point is located at the boom/grapple pivot pin.
4. Manufacturer assumes no responsibility for the proper fit or structural integrity of the mounting pedestal and/or platform supplied by the customer.
5. Operator should be fully acquainted with the Operator's Manual and all safety instructions furnished prior to operating the machine.
6. Lift capacities are in compliance with SAE J2417, "Lift Capacity Calculation Method — Knuckleboom Log Loaders and Certain Forestry Equipment."

	1.5 m/5'0"		3 m/10'0"		4.6 m/15'0"		6.1 m/20'0"		7.6 m/25'0"	
	kg	lb	kg	lb	kg	lb	kg	lb	kg	lb
7.6 m (25'0")					<i>5021</i> 4368	<i>11,060</i> <b>9,622</b>				
6.1 m (20'0")					<i>5177</i> 4504	<i>11,402</i> <b>9,920</b>	<i>4486</i> 3903	<i>9,882</i> <b>8,597</b>		
4.6 m (15'0")					<i>5311</i> 4620	<i>11,698</i> <b>10,177</b>	<i>4634</i> 4032	<i>10,207</i> <b>8,880</b>		
3.0 m (10'0")			<i>3788</i> 3295	<i>8,343</i> <b>7,258</b>	<i>5854</i> 5093	<i>12,894</i> <b>11,218</b>	<i>4799</i> 4175	<i>10,571</i> <b>9,197</b>	<i>3962</i> 3447	<i>8,728</i> <b>7,593</b>
1.5 m (5'0")					<i>7229</i> 6289	<i>15,923</i> <b>13,853</b>	<i>5951</i> 5177	<i>13,107</i> <b>11,403</b>	<i>3890</i> 3384	<i>8,568</i> <b>7,454</b>
0 m (0'0")					<i>8730</i> 6603	<i>19,229</i> <b>16,729</b>	<i>6469</i> 5628	<i>14,249</i> <b>12,397</b>	<i>4061</i> 3533	<i>8,946</i> <b>7,783</b>
-1.5 m (-5'0")			<i>4764</i> 4145	<i>10,494</i> <b>9,130</b>	<i>8057</i> 7010	<i>17,747</i> <b>15,440</b>	<i>5811</i> 5056	<i>12,800</i> <b>11,136</b>	<i>3040</i> 2645	<i>6,697</i> <b>5,826</b>
-3.0 m (-10'0")	<i>3050</i> 2654	<i>6,718</i> <b>5,845</b>	<i>6276</i> 5460	<i>13,824</i> <b>12,027</b>	<i>6152</i> 5353	<i>13,552</i> <b>11,790</b>	<i>4083</i> 3552	<i>8,993</i> <b>7,824</b>		
-4.6 m (-15'0")			<i>3494</i> 3040	<i>7,697</i> <b>6,696</b>	<i>2564</i> 2231	<i>5,648</i> <b>4,914</b>				

# Forest Products Stationary Mount Knuckleboom Loaders

## Lift and Range Diagram

- 519 SM Knuckleboom Loader
- 519 SM/EHC Knuckleboom Loader

### 519 SM/519 SM/EHC 9.1 m (30'0") Boom

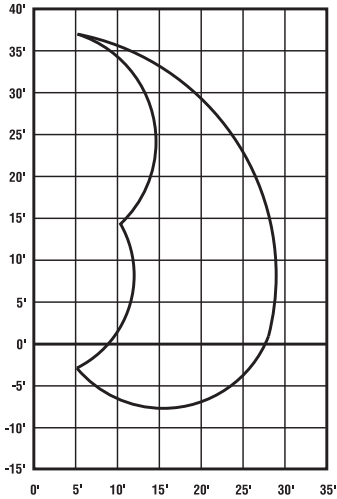

#### NOTES:

Do not attempt to lift or hold any load that is greater than the rated values over the end or side at their specified lift point and height. The weight of the grapple and all lifting accessories must be deducted from lift capacities shown.

1. All figures shown in these charts represent rated lift capacities.
2. Capacities shown in *italic* are 100% of hydraulic capacity; other capacities shown are 87% of hydraulic capability.
3. The lift point is located at the boom/grapple pivot pin.
4. Manufacturer assumes no responsibility for the proper fit or structural integrity of the mounting pedestal and/or platform supplied by the customer.
5. Operator should be fully acquainted with the Operator's Manual and all safety instructions furnished prior to operating the machine.
6. Lift capacities are in compliance with SAE J2417, "Lift Capacity Calculation Method — Knuckleboom Log Loaders and Certain Forestry Equipment."

	1.5 m/5'0"		3 m/10'0"		4.6 m/15'0"		6.1 m/20'0"		7.6 m/25'0"		9.1 m/30'0"	
	kg	lb	kg	lb	kg	lb	kg	lb	kg	lb	kg	lb
9.1 m (30'0")					4206 3659	<i>9,264</i> <i>8,060</i>						
7.6 m (25'0")					4714 4101	<i>10,384</i> <i>9,034</i>	3940 3428	<i>8,679</i> <i>7,551</i>				
6.1 m (20'0")							4179 3636	<i>9,206</i> <i>8,009</i>	3088 2687	<i>6,802</i> <i>5,918</i>		
4.6 m (15'0")					4419 3845	<i>9,734</i> <i>8,469</i>	4267 3712	<i>9,398</i> <i>8,176</i>	3713 3230	<i>8,178</i> <i>7,115</i>		
3.0 m (10'0")					4942 4300	<i>10,886</i> <i>9,471</i>	4488 3904	<i>9,885</i> <i>8,600</i>	3769 3279	<i>8,301</i> <i>7,222</i>		
1.5 m (5'0")					6380 5551	<i>14,053</i> <i>12,226</i>	5670 4933	<i>12,490</i> <i>10,866</i>	4407 3834	<i>9,707</i> <i>8,445</i>	1996 1737	<i>4,397</i> <i>3,825</i>
0 m (0'0")					8448 7350	<i>18,608</i> <i>16,189</i>	6299 5480	<i>13,874</i> <i>12,070</i>	4873 4239	<i>10,733</i> <i>9,338</i>		
-1.5 m (-5'0")			2892 2516	<i>6,369</i> <i>5,541</i>	7983 6945	<i>17,583</i> <i>15,297</i>	5894 5128	<i>12,983</i> <i>11,295</i>	4320 3758	<i>9,515</i> <i>8,278</i>		
-3.0 m (-10'0")	2039 1774	<i>4,492</i> <i>3,908</i>	4532 3943	<i>9,983</i> <i>8,685</i>	6538 5688	<i>14,401</i> <i>12,529</i>	4775 4154	<i>10,517</i> <i>9,150</i>	2937 2556	<i>6,470</i> <i>5,629</i>		
-4.6 m (-15'0")			4942 4299	<i>10,885</i> <i>9,470</i>	3981 3463	<i>8,768</i> <i>7,628</i>	2518 2191	<i>5,547</i> <i>4,826</i>				

- Lift and Range Diagram
- 569 SM Knuckleboom Loader
- 569 SM/EHC Knuckleboom Loader

## Forest Products Stationary Mount Knuckleboom Loaders

### 569 SM/569 SM/EHC 9.6 m (32'6") Boom

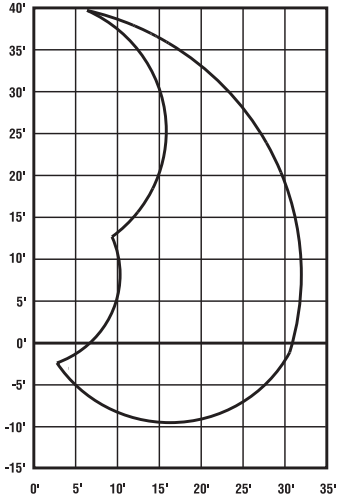

#### NOTES:

Do not attempt to lift or hold any load that is greater than the rated values over the end or side at their specified lift point and height. The weight of the grapple and all lifting accessories must be deducted from lift capacities shown.

1. All figures shown in these charts represent rated lift capacities.
2. Capacities shown in *italic* are 100% of hydraulic capacity; other capacities shown are 87% of hydraulic capability.
3. The lift point is located at the boom/grapple pivot pin.
4. Manufacturer assumes no responsibility for the proper fit or structural integrity of the mounting pedestal and/or platform supplied by the customer.
5. Operator should be fully acquainted with the Operator's Manual and all safety instructions furnished prior to operating the machine.
6. Lift capacities are in compliance with SAE J2417, "Lift Capacity Calculation Method — Knuckleboom Log Loaders and Certain Forestry Equipment."

6

	1.5 m/5'0"		3 m/10'0"		4.6 m/15'0"		6.1 m/20'0"		7.6 m/25'0"		9.1 m/30'0"	
	kg	lb	kg	lb	kg	lb	kg	lb	kg	lb	kg	lb
9.1 m (30'0")												
7.6 m (25'0")							<i>5118</i> 4453	<i>11,274</i> 9,808				
6.1 m (20'0")							<i>5850</i> 5089	<i>12,885</i> 11,210	<i>4577</i> 3982	<i>10,082</i> 8,771		
4.6 m (15'0")							<i>6422</i> 5587	<i>14,145</i> 12,306	<i>5560</i> 4837	<i>12,247</i> 10,655	<i>2997</i> 2607	<i>6,601</i> 5,743
3.0 m (10'0")					<i>7558</i> 6575	<i>16,647</i> 14,483	<i>7002</i> 6091	<i>15,422</i> 13,417	<i>6115</i> 5320	<i>13,470</i> 11,719	<i>4093</i> 3561	<i>9,016</i> 7,844
1.5 m (5'0")					<i>10 730</i> 9335	<i>23,634</i> 20,562	<i>8567</i> 7453	<i>18,870</i> 16,417	<i>7127</i> 6200	<i>15,698</i> 13,657	<i>4740</i> 4124	<i>10,441</i> 9,084
0 m (0'0")			<i>18 803</i> 16 359	<i>41,417</i> 36,033	<i>12 247</i> 10 654	<i>26,975</i> 23,468	<i>9179</i> 7985	<i>20,217</i> 17,589	<i>7305</i> 6355	<i>16,090</i> 13,998	<i>4939</i> 4297	<i>10,878</i> 9,464
-1.5 m (-5'0")			<i>9850</i> 8569	<i>21,695</i> 18,875	<i>12 595</i> 10 957	<i>27,741</i> 24,135	<i>9205</i> 8008	<i>20,275</i> 17,639	<i>7026</i> 6112	<i>15,475</i> 13,463		
-3.0 m (-10'0")	<i>3712</i> 3230	<i>8,177</i> 7,114	<i>9507</i> 8271	<i>20,940</i> 18,218	<i>11 367</i> 9889	<i>25,037</i> 21,782	<i>8250</i> 7178	<i>18,172</i> 15,810	<i>5897</i> 5131	<i>12,990</i> 11,301		

# Forest Products Stationary Mount Knuckleboom Loaders

## Lift and Range Diagram

- 569 SM Knuckleboom Loader
- 569 SM/EHC Knuckleboom Loader

### 569 SM/569 SM/EHC 10.9 m (36'0") Boom

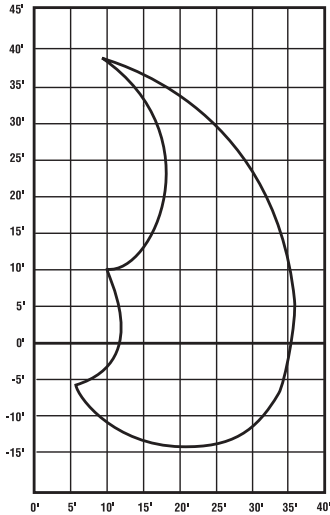

#### NOTES:

Do not attempt to lift or hold any load that is greater than the rated values over the end or side at their specified lift point and height. The weight of the grapple and all lifting accessories must be deducted from lift capacities shown.

1. All figures shown in these charts represent rated lift capacities.
2. Capacities shown in *italic* are 100% of hydraulic capacity; other capacities shown are 87% of hydraulic capability.
3. The lift point is located at the boom/grapple pivot pin.
4. Manufacturer assumes no responsibility for the proper fit or structural integrity of the mounting pedestal and/or platform supplied by the customer.
5. Operator should be fully acquainted with the Operator's Manual and all safety instructions furnished prior to operating the machine.
6. Lift capacities are in compliance with SAE J2417, "Lift Capacity Calculation Method — Knuckleboom Log Loaders and Certain Forestry Equipment."

	3 m/10'0"		4.6 m/15'0"		6.1 m/20'0"		7.6 m/25'0"		9.1 m/30'0"		10.6 m/35'0"	
	kg	lb	kg	lb	kg	lb	kg	lb	kg	lb	kg	lb
10.6 m (35'0")			<i>5110</i> 4446	<i>11,255</i> 9,792								
9.1 m (30'0")					<i>4985</i> 4337	<i>10,979</i> 9,552						
7.6 m (25'0")					<i>5744</i> 4998	<i>12,653</i> 11,008	<i>4697</i> 4086	<i>10,345</i> 9,000				
6.1 m (20'0")					<i>6087</i> 5295	<i>13,407</i> 11,664	<i>5508</i> 4792	<i>12,132</i> 10,555	<i>3943</i> 3430	<i>8,685</i> 7,556		
4.6 m (15'0")					<i>6629</i> 5767	<i>14,601</i> 12,703	<i>5997</i> 5218	<i>13,210</i> 11,493	<i>5037</i> 4382	<i>11,094</i> 9,652		
3.0 m (10'0")			<i>8808</i> 7663	<i>19,400</i> 16,878	<i>7924</i> 6894	<i>17,454</i> 15,185	<i>6701</i> 5830	<i>14,761</i> 12,842	<i>5444</i> 4737	<i>11,992</i> 10,433	<i>2748</i> 2391	<i>6,053</i> 5,266
1.5 m (5'0")			<i>11 401</i> 9919	<i>25,113</i> 21,848	<i>8652</i> 7527	<i>19,057</i> 16,580	<i>7024</i> 6111	<i>15,472</i> 13,461	<i>5873</i> 5109	<i>12,936</i> 11,254	<i>3306</i> 2877	<i>7,283</i> 6,336
0 m (0'0")			<i>12 364</i> 10 757	<i>27,233</i> 23,693	<i>9096</i> 7914	<i>20,036</i> 17,431	<i>7171</i> 6239	<i>15,795</i> 13,742	<i>5804</i> 5049	<i>12,784</i> 11,122	<i>3200</i> 2784	<i>7,048</i> 6,132
-1.5 m (-5'0")	<i>4876</i> 4242	<i>10,740</i> 9,344	<i>12 156</i> 10 575	<i>26,775</i> 23,294	<i>8973</i> 7806	<i>19,763</i> 17,194	<i>6956</i> 6051	<i>15,321</i> 13,329	<i>5420</i> 4716	<i>11,939</i> 10,387		
-3.0 m (-10'0")	<i>5803</i> 5049	<i>12,783</i> 11,121	<i>10 713</i> 9321	<i>23,598</i> 20,530	<i>8081</i> 7030	<i>17,799</i> 15,485	<i>6170</i> 5368	<i>13,591</i> 11,824	<i>4454</i> 3875	<i>9,810</i> 8,535		

**Wheel Loader and Integrated Toolcarrier  
Forestry Features:**

**NOTE:** For more information on the complete line of Cat Wheel Loaders and Integrated Toolcarriers, see section 12 of the performance handbook.

**988H** — Logging Arrangement equips the 988H with heavy-duty tilt cylinders, additional counterweight, and heavy-duty tires (42PL R-5) for strength and durability required in millyard and logging applications. Work tool attachments, such as logging forks are designed for heavy-duty applications; loading and unloading trucks, sorting, decking and feeding the mill.

**980H** — Forest Machine Arrangement equips the 980H with an extreme service transmission, heavy-duty tilt cylinders and 2041 kg (4500 lb) counterweight for the strength and durability required to be productive in this tough application. Logging, millyard and wood pallet forks, woodchip and clean-up buckets can be added to equip the 980H for forestry applications.

**966H/950H** — Forest Machine Arrangements on the 966H and 950H provide ride control, heavy-duty tilt cylinders and an additional counterweights for use in forestry and logging applications. Specially designed work tools for forestry applications can be factory-installed.

**IT62H** — From pallet forks up through specialized logging arrangements, loader forks are available for a wide range of jobs, making the IT62H an efficient and versatile machine.

- **Core Forks** — Superior design makes these the logical choice for plywood mills and millyards.
- **Grapple Forks** — With kickout offer many high-performance log-handling features such as easy loading, increased dump clearance and improved sorting ability.
- **Logging Forks** — Designed for heavy-duty applications; loading and unloading trucks, sorting, decking and feeding the mill.
- **Lumber and Log Forks** — Ideal for a wide range of jobs; loading, decking and sorting lumber, logs or palletized material.
- **Millyard Forks** — Used for unloading, sorting, decking, feeding logs into the mill; millyard forks maximize loader efficiency in millyard applications.
- **Pallet Forks** — When used with quick coupler, pallet forks increase the versatility of the machine, making them ideal for handling a variety of material.

MODEL	988H LL	
Operating Weight	58 535 kg	129,047 lb
Engine Model	<b>C18 ACERT</b>	
Full Turn Static Tipping Load (Logging Forks)	31 630 kg	69,732 lb
	@ 37 degree articulation	

- 928Hz
- 988H

**928Hz with Pin-On  
Cat Lumber and Log Fork**

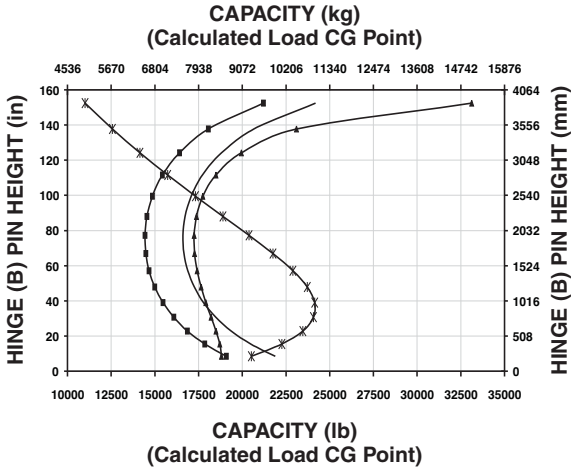

**988H with Quick Coupler and  
Cat Millyard Fork**

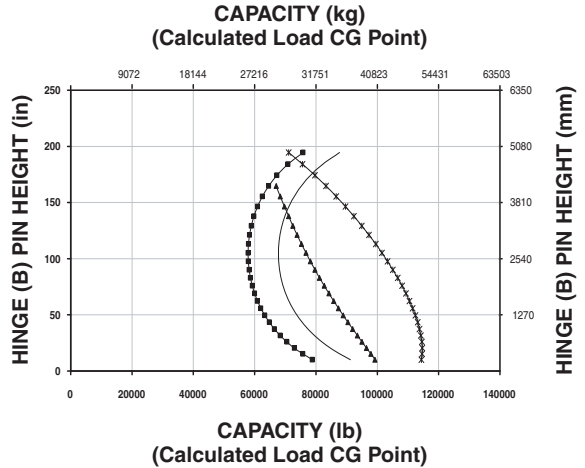

**KEY**

- Tipping Capacity with Machine Straight Fork Level
- Tipping Capacity with Machine Articulated Fork Level
- ▲ Hydraulic Lift Capacity with Fork Level
- \* Hydraulic Tilt Capacity with Fork Level

Curves based on machine with 928Hz with cab and AC, optional counterweight, limited slip axles, heavy duty rear brakes, additional guarding, sound suppression, 80 kg (176 lb) operator, Michelin 20.5 R25 XHA tires, and 141-6252 log and lumber fork configured with 1219 mm (48") tines without top clamp. Fork weight is 707 kg (1555 lb) and machine operating weight is 12 324 kg (27,113 lb). Forks of other dimensions or weight may affect machine capacity. Hydraulic capacities are calculated for system pressure. Consult your Cat dealer for additional fork data.

Curves based on machine with full fuel tank, operator, ROPS cab, 35/65-33 30 PR (L-4) tires. Standard 4455 kg (9825 lb) counterweight, 2690 kg (5930 lb) ballast in rear tires, 5196C2 millyard fork at 5480 kg (12,080 lb). Total operating weight, 52 765 kg (116,325 lb). Forks or other dimensions or weight will affect machine capacity.

**NOTE:** Static tipping load and operating weight are based on machine configuration with standard tires, full fuel tank, coolant, lubricants, and operator.

Specifications and ratings conform to all applicable standards recommended by the Society of Automotive Engineers (SAE). SAE Standards J732 JUN92 and J742 FEB85 govern loader ratings.

The rated operating load for a machine with fork is: SAE J1197; 50% of full turn static tipping load, or hydraulic/structural limit. CEN 474-3: 60% of full turn tipping load on rough terrain: 80% of full turn tipping load on firm and level ground, or hydraulic structural limit.

**988H with Pin-On  
Cat Logging Fork**

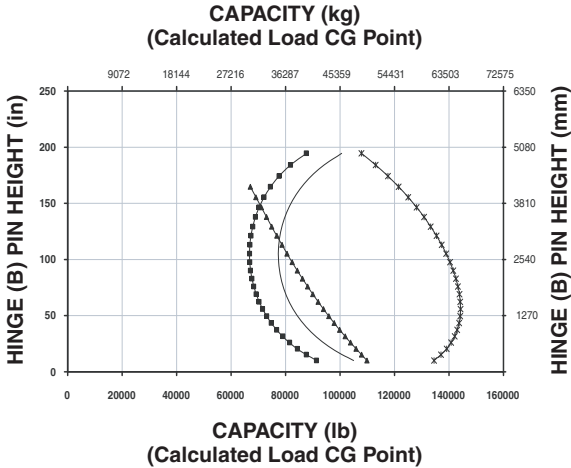

**990H with Pin-On  
Cat Logging Fork**

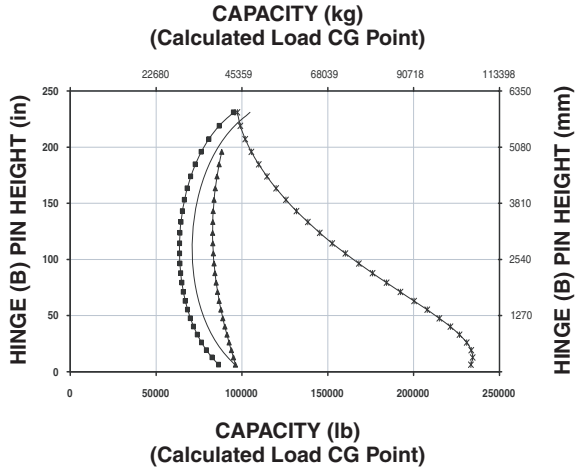

**KEY**

- Tipping Capacity with Machine Straight Fork Level
- Tipping Capacity with Machine Articulated Fork Level
- ▲ Hydraulic Lift Capacity with Fork Level
- \* Hydraulic Tilt Capacity with Fork Level

Curves based on machine with full fuel tank, operator, ROPS cab, 35/65-33 30 PR (L-4) tires. Standard log 4455 kg (9825 lb) counterweight, 2690 kg (5930 lb) ballast in rear tires, 8965C DTC log fork at 4490 kg (9900 lb). Total operating weight 51 775 kg (114,160 lb).

Curves based on machine with full fuel tank, operator, ROPS cab, 45/65x39 X-MINE D2 radial tires 4788 kg (10,555 lb) ballast in rear tires, 7845 kg (17,295 lb) logger counterweight, 114-3557.02 log fork with 2438 mm (8'0") tines and top clamp at 5896 kg (13,000 lb), 1292.1 mm (4'3") link. Total operating weight 87 705 kg (193,360 lb).

**NOTE:** Static tipping load and operating weight are based on machine configuration with standard tires, full fuel tank, coolant, lubricants, and operator.

Specifications and ratings conform to all applicable standards recommended by the Society of Automotive Engineers (SAE). SAE Standards J732 JUN92 and J742 FEB85 govern loader ratings.

The rated operating load for a machine with fork is: SAE J1197; 50% of full turn static tipping load, or hydraulic/structural limit. CEN 474-3: 60% of full turn tipping load on rough terrain: 80% of full turn tipping load on firm and level ground, or hydraulic structural limit.



- IT14G
- 924H

**IT14G with Pin-On  
Cat Lumber and Log Fork**

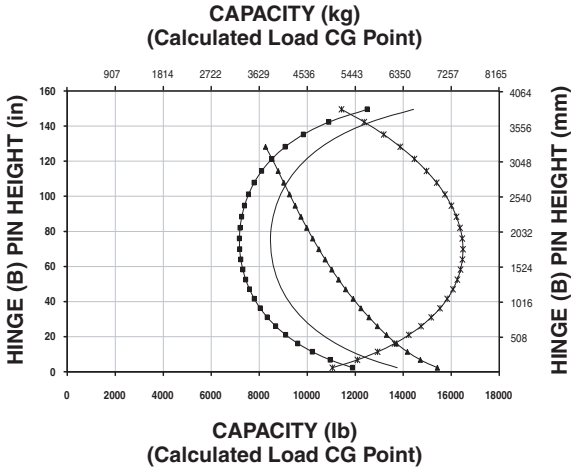

**924H with Quick Coupler and  
Cat Lumber and Log Fork**

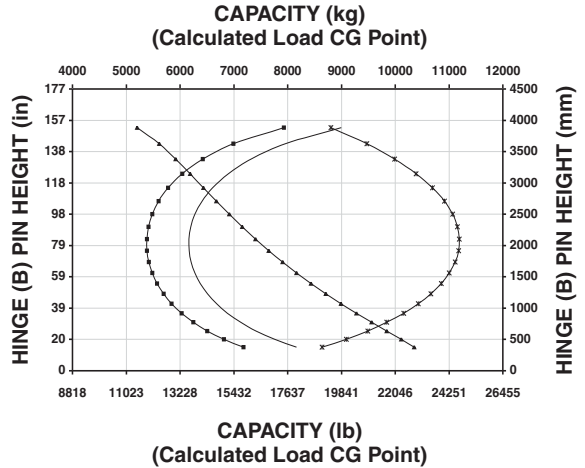

**KEY**

- Tipping Capacity with Machine Straight Fork Level
- Tipping Capacity with Machine Articulated Fork Level
- ▲ Hydraulic Lift Capacity with Fork Level
- \* Hydraulic Tilt Capacity with Fork Level

Curves and operating weight are based on machine equipped with 17.5R25 tires, full fuel tank, 9816C2 lumber and log fork without top clamp. Fork weight is 803 kg (1770 lb). Total operating weight 8020 kg (17,668 lb). Forks of other dimensions or weight may affect machine capacity. Consult your Cat dealer for additional fork data.

Curves based on machine with 924H with cab and AC, optional counterweight, limited slip axles, heavy duty rear brakes, additional guarding, sound suppression, 80 kg (176 lb) operator, Michelin 20.5 R25 XHA tires, and 180-8355 log and lumber fork configured with 1219 mm (48") tines without top clamp. Fork weight is 800 kg (1760 lb) and machine operating weight is 11 555 kg (25,421 lb). Forks of other dimensions or weight may affect machine capacity. Hydraulic capacities are calculated for system pressure. Consult your Cat dealer for additional fork data.

**NOTE:** Static tipping load and operating weight are based on machine configuration with standard tires, full fuel tank, coolant, lubricants, and operator.

Specifications and ratings conform to all applicable standards recommended by the Society of Automotive Engineers (SAE). SAE Standards J732 JUN92 and J742 FEB85 govern loader ratings.

The rated operating load for a machine with fork is: SAE J1197; 50% of full turn static tipping load, or hydraulic/structural limit. CEN 474-3: 60% of full turn tipping load on rough terrain; 80% of full turn tipping load on firm and level ground, or hydraulic structural limit.

**930H with Pin-On  
Cat Lumber and Log Fork**

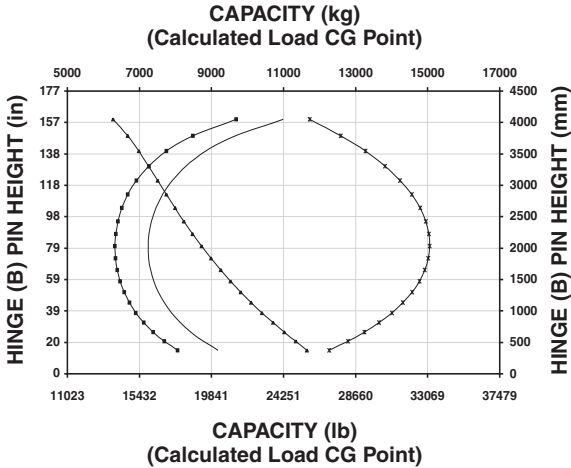

**KEY**

- Tipping Capacity with Machine Straight Fork Level
- Tipping Capacity with Machine Articulated Fork Level
- ▲ Hydraulic Lift Capacity with Fork Level
- ✱ Hydraulic Tilt Capacity with Fork Level

Curves based on machine with 930H with cab and AC, optional counterweight, limited slip axles, heavy duty rear brakes, additional guarding, sound suppression, 80 kg (176 lb) operator, Michelin 20.5 R25 XHA tires, and 180-8355 log and lumber fork configured with 1219 mm (48") tines without top clamp. Fork weight is 800 kg (1760 lb) and machine operating weight is 12 935 kg (28,457 lb). Forks of other dimensions or weight may affect machine capacity. Hydraulic capacities are calculated for system pressure. Consult your Cat dealer for additional fork data.

**NOTE:** Static tipping loads and operating weight are based on machine configuration with standard tires, full fuel tank, coolant, lubricants, and operator. Static tipping loads conform to the international standard as defined in ISO 14397-1 (SEPT2007).

Specifications and ratings conform to all applicable standards recommended by the Society of Automotive Engineers (SAE) and European Committee for Standardization (CEN): SAE J1197, SAE J732, CEN EN 474-3.

The rated operating load for a machine with fork is: SAE J1197; 50% of full turn static tipping load, or hydraulic/structural limit. CEN 474-3: 60% of full turn tipping load on rough terrain: 80% of full turn tipping load on firm and level ground, or hydraulic structural limit.

**938H with  
Pin-On Logging Fork**

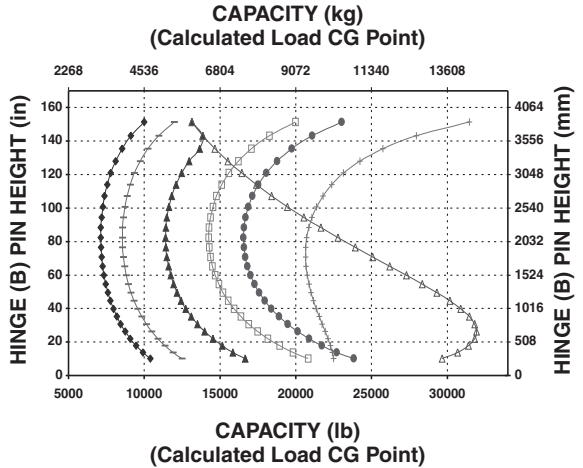

**KEY**

- ◆ Payload (SAE J1197)
- Payload (CEN EN 474-3 — Rough Terrain)
- ▲ Payload (CEN EN 474-3 — Firm and Level)
- Static Tipping Load — Articulated
- Static Tipping Load — Straight
- △ Hydraulic Tilt Capacity

Curves based on machine equipped with 20.5R25 Michelin XHA tires, 610 kg (1345 lb) counterweight, full fuel tank, and logging fork 292-4050. Fork weight is 1677 kg (3697 lb) and machine operating weight is 15 384 kg (33,906 lb). Forks of other dimensions or weight may affect machine capacity. Consult your Cat dealer for additional data.

- 950H
- 966H

**950H with  
Pin-On Millyard Fork**

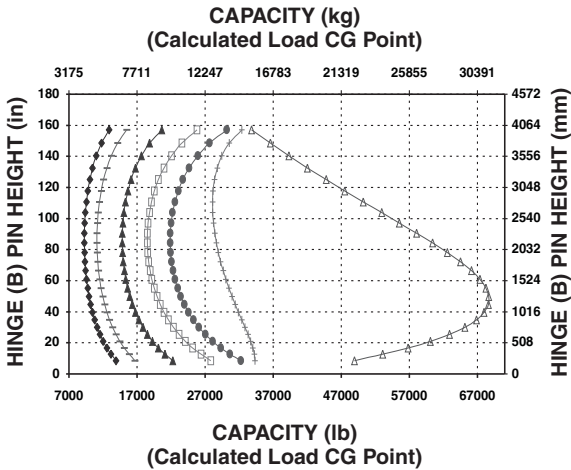

**966H with  
Pin-On Logging Fork**

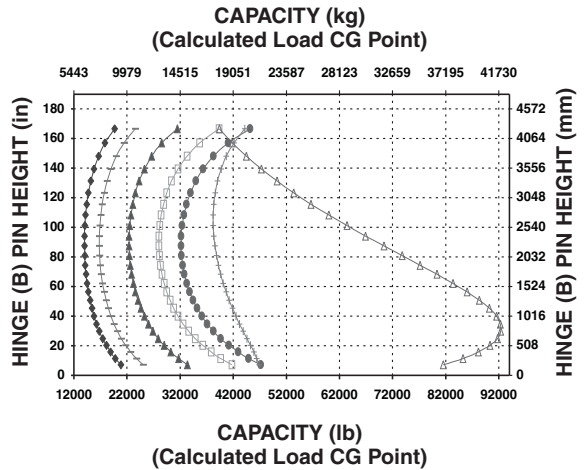

**KEY**

- ◆ Payload (SAE J1197)
- Payload (CEN EN 474-3 — Rough Terrain)
- ▲ Payload (CEN EN 474-3 — Firm and Level)
- Static Tipping Load — Articulated
- Static Tipping Load — Straight
- △ Hydraulic Tilt Capacity

Curves based on machine equipped with 23.5R25 Michelin XHA tires, 1400 kg (3086 lb) counterweight, full fuel tank, and millyard fork 256-7361. Fork weight is 2515 kg (5545 lb) and machine operating weight is 19 714 kg (43,449 lb). Forks of other dimensions or weight may affect machine capacity. Consult your Cat dealer for additional data.

Curves based on machine equipped with 26.5R25 Michelin XHA tires, 2650 kg (5842 lb) counterweight, full fuel tank, and logging fork 253-7320. Fork weight is 2681 kg (5911 lb) and machine operating weight is 25 471 kg (56,138 lb). Forks of other dimensions or weight may affect machine capacity. Consult your Cat dealer for additional data.

**NOTE:** Static tipping loads and operating weight are based on machine configuration with standard tires, full fuel tank, coolant, lubricants, and operator. Static tipping loads conform to the international standard as defined in ISO 14397-1 (SEPT2007).

Specifications and ratings conform to all applicable standards recommended by the Society of Automotive Engineers (SAE) and European Committee for Standardization (CEN): SAE J1197, SAE J732, CEN EN 474-3.

The rated operating load for a machine with fork is: SAE J1197; 50% of full turn static tipping load, or hydraulic/structural limit. CEN 474-3: 60% of full turn tipping load on rough terrain: 80% of full turn tipping load on firm and level ground, or hydraulic structural limit.

980H with  
Pin-On Millyard Fork

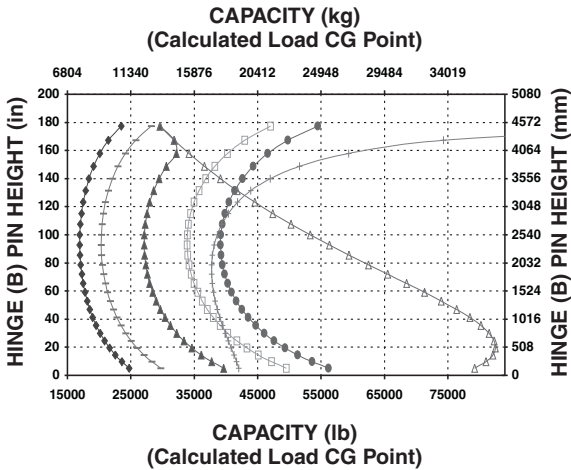

IT38H with  
Quick Coupler and Millyard Fork

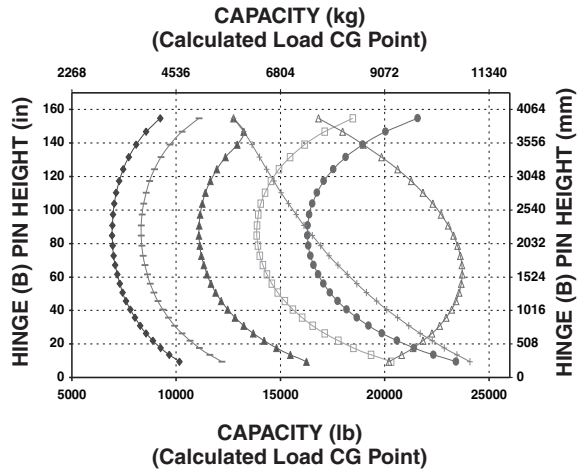

KEY

- ◆ Payload (SAE J1197)
- Payload (CEN EN 474-3 — Rough Terrain)
- ▲ Payload (CEN EN 474-3 — Firm and Level)
- Static Tipping Load — Articulated
- Static Tipping Load — Straight
- △ Hydraulic Tilt Capacity

Curves based on machine equipped with 29.5R25 Michelin XHA tires, 3400 kg (7496 lb) counterweight, full fuel tank, and millyard fork 192-7656. Fork weight is 3262 kg (7191 lb) and machine operating weight is 32 406 kg (71,422 lb). Forks of other dimensions or weight may affect machine capacity. Consult your Cat dealer for additional data.

Curves based on machine equipped with 20.5R25 Michelin XHA tires, 1330 kg (2932 lb) counterweight, full fuel tank, and millyard fork 103-8617 with 268-8218 coupler. Fork weight is 1816 kg (4004 lb) and machine operating weight is 16 802 kg (37,301 lb). Forks of other dimensions or weight may affect machine capacity. Consult your Cat dealer for additional data.

**NOTE:** Static tipping loads and operating weight are based on machine configuration with standard tires, full fuel tank, coolant, lubricants, and operator. Static tipping loads conform to the international standard as defined in ISO 14397-1 (SEPT2007).

Specifications and ratings conform to all applicable standards recommended by the Society of Automotive Engineers (SAE) and European Committee for Standardization (CEN): SAE J1197, SAE J732, CEN EN 474-3.

The rated operating load for a machine with fork is: SAE J1197; 50% of full turn static tipping load, or hydraulic/structural limit. CEN 474-3: 60% of full turn tipping load on rough terrain; 80% of full turn tipping load on firm and level ground, or hydraulic structural limit.

**WORK TOOLS**

Grapples for Heel Boom Log Loaders  
    Features . . . . .6-76  
    Dimensions . . . . .6-77  
Logging Forks  
    Features . . . . .6-78  
    Specifications . . . . .6-78  
Couplers  
    Features . . . . .6-81  
Buckets and Thumbs  
    Features . . . . .6-81  
Woodchip Dozers and Scoops  
    Features . . . . .6-82  
    Specifications . . . . .6-82  
Rakes  
    Features . . . . .6-83

**Features:**

- **Full 360° continuous rotation.**
- **Paddle style tines** are made of high strength steel, and use abrasion resistant material on tips for longer life.
- **Induction hardened** pins and bushings.
- **Heavy duty hydraulic cylinders** with built in check valves, and protective hose guarding for more uptime.

Dimensions for Log Loading Grapples

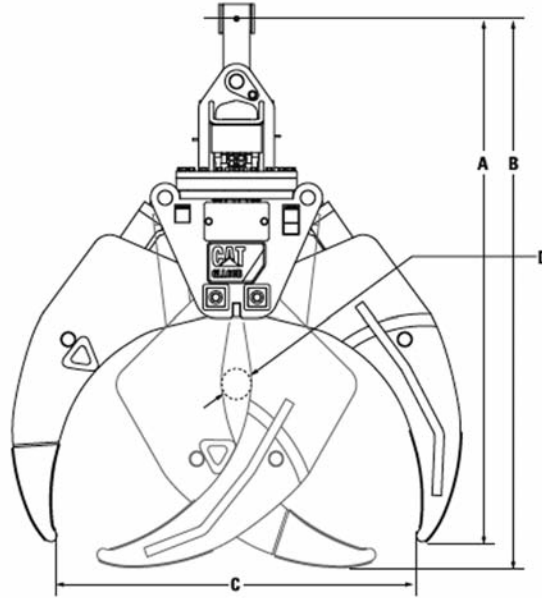

6

	<b>GLL52</b>		<b>GLL55</b>		<b>GLL60</b>	
<b>Part Number</b>	<b>271-1533</b>		<b>271-1534</b>		<b>271-1535</b>	
Weight	1255 kg	<b>2767 lb</b>	1291 kg	<b>2840 lb</b>	1344 kg	<b>2965 lb</b>
Width	673 mm	<b>26.5"</b>	673 mm	<b>26.5"</b>	673 mm	<b>26.5"</b>
<b>A</b> Height, Open	2134 mm	<b>84"</b>	2184 mm	<b>86"</b>	2261 mm	<b>89"</b>
<b>B</b> Height, Closed	2159 mm	<b>85"</b>	2210 mm	<b>87"</b>	2286 mm	<b>90"</b>
<b>C</b> Maximum Opening	1321 mm	<b>52"</b>	1397 mm	<b>55"</b>	1524 mm	<b>60"</b>
<b>D</b> Minimum Opening	127 mm	<b>5"</b>	127 mm	<b>5"</b>	127 mm	<b>5"</b>
Rotation, Continuous	<b>360°</b>		<b>360°</b>		<b>360°</b>	
Rotation, Torque @ 8273 kPa (1200 psi)	1153 N-m	<b>850 ft-lb</b>	1153 N-m	<b>850 ft-lb</b>	1153 N-m	<b>850 ft-lb</b>

- Features
- Specifications

**Features:**

**Loader Fork**

- Few work tool lines can match the range and utility of Cat Forks. Forks transform loaders into high performance material handling platforms capable of sorting, stacking and working wherever product, palletized material or lumber is at hand.

**Millyard and Logging Forks**

- Cat Millyard and double top clamp forks are performance-matched to 966H Wheel Loaders for unmatched on-the-job performance. The design features of fork and loader complement each other to make the ideal total system solution for log handling applications. Both forks are ideally suited for heavy-duty applications: loading and unloading trucks, sorting, decking, and feeding the mill.

**Log and Lumber Forks**

- Handle logs or finished lumber with equal ease. The top clamp holds loose loads securely, and the pallet-style forks make short palletized material. This versatility makes them suitable for a wide range of jobs including loading trucks, decking and sorting lumber or logs.

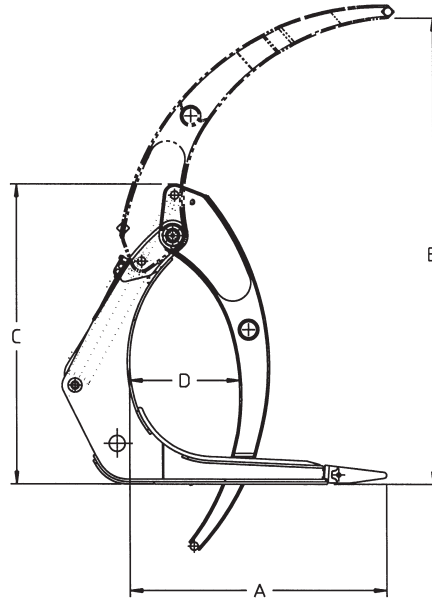
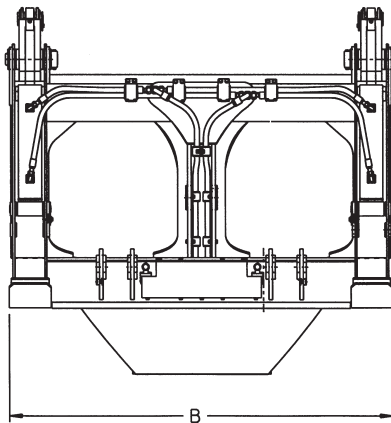

MODEL	IT28G	938H	IT38H	950H/962H	950H/962H
<b>Model</b>	<b>Millyard Fork</b>	<b>Millyard Fork</b>	<b>Millyard Fork</b>	<b>Millyard Fork</b>	<b>Logging Fork</b>
<b>Group Number</b>					
<b>Logging Arrangement</b>	<b>250-7011</b>	<b>292-4050</b>	<b>103-8617</b>	<b>256-7361</b>	<b>257-1959</b>
<b>Linkage Arrangement</b>	<b>(Quick Coupler)</b>	<b>(Pin-On)</b>	<b>(Coupler)</b>	<b>(Pin-On)</b>	<b>(Pin-On)</b>
<b>A — Tine Length</b>	1219 mm <b>4'0"</b>	1372 mm <b>4'6"</b>	1363 mm <b>4'6"</b>	1618 mm <b>5'4"</b>	1626 mm <b>5'4"</b>
<b>B — Overall Width</b>	1778 mm <b>5'10"</b>	2288 mm <b>7'6"</b>	2608 mm <b>8'7"</b>	2724 mm <b>8'11"</b>	2261 mm <b>7'5"</b>
<b>C — Back Height</b>	1886 mm <b>6'2"</b>	1842 mm <b>6'1"</b>	—	1919 mm <b>6'3"</b>	1895 mm <b>6'2"</b>
<b>D — Minimum Opening</b>	—	165 mm <b>6.5"</b>	—	—	1535 mm <b>5'0"</b>
<b>E — Maximum Clamp Opening</b>	2705 mm <b>8'10"</b>	2794 mm <b>9'2"</b>	—	—	2520 mm <b>8'4"</b>
<b>Weight, Approximate</b>	—	1677 kg <b>3697 lb</b>	1816 kg <b>4004 lb</b>	2515 kg <b>5545 lb</b>	2200 kg <b>4860 lb</b>

**NOTE:** Third valve required. Counterweight recommended.  
 Logging forks with millyard style clamps are available where logging application requires clamp to close between tines.  
 Contact your Cat dealer for more information.

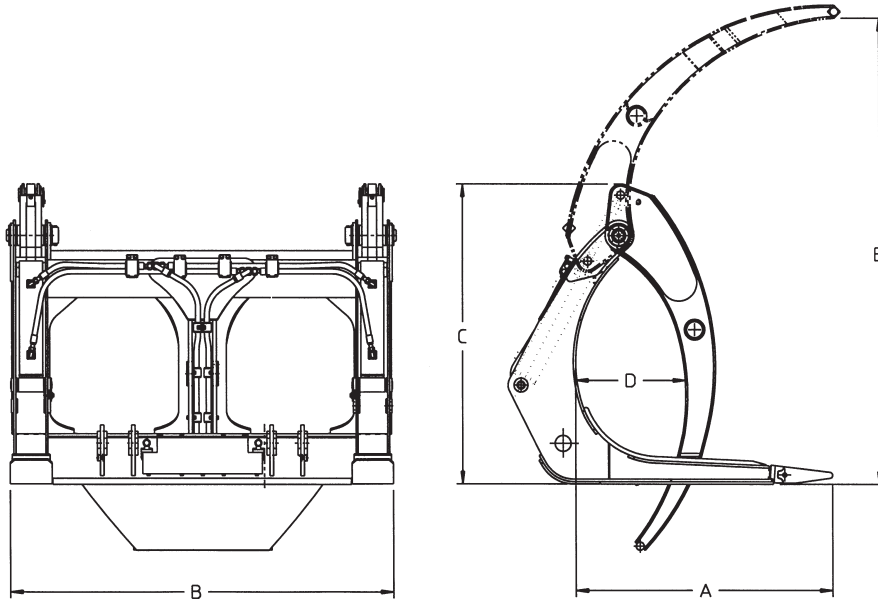

MODEL	950H/962H		IT62H		IT62H		IT62H	
Model	Logging Fork		Millyard		Double Top Clamp		Log and Lumber with Top Clamp	
Group Number	257-1960		163-0193		163-0194		114-3532	
Logging Arrangement	(Coupler)		(Coupler)		(Coupler)		(Coupler)	
Linkage Arrangement								
A — Tine Length	1626 mm	5'4"	1626 mm	5'4"	1620 mm	5'4"	1219 mm	4'0"
B — Overall Width	2261 mm	7'5"	2261 mm	7'5"	2261 mm	7'5"	2248 mm	7'5"
C — Back Height	1895 mm	6'2"	1872 mm	6'2"	1895 mm	6'3"	1726 mm	5'8"
D — Minimum Opening	1535 mm	5'0"	448 mm	17.64"	1537 mm	5'1"	1217 mm	4'0"
E — Maximum Clamp Opening	2520 mm	8'4"	2914 mm	9'7"	2565 mm	8'5"	2798 mm	9'2"
Weight, Approximate	2200 kg	4860 lb	2179 kg	4800 lb	2221 kg	4892 lb	863 kg	1900 lb

MODEL	966H		966H		966H	
Model	Millyard		Logging		Log and Lumber W/TC	
Group Number	253-7320		255-7333		143-7209	
Logging Arrangement						
Linkage Arrangement						
A — Tine Length	1618 mm	5'4"	1618 mm	5'4"	1524 mm	5'0"
B — Overall Width	2416 mm	7'11"	2416 mm	7'11"	2502 mm	8'3"
C — Back Height	1905 mm	6'3"	1897 mm	6'3"	1726 mm	5'8"
D — Minimum Opening	697 mm	2'3"	1603 mm	5'3"	1506 mm	4'11"
E — Maximum Clamp Opening	2927 mm	9'7"	2563 mm	8'5"	2794 mm	9'2"
Weight, Approximate	2681 kg	5911 lb	2300 kg	5065 lb	1585 kg	3491 lb

**NOTE:** Third valve required. Counterweight recommended.  
Logging forks with millyard style clamps are available where logging application requires clamp to close between tines.  
Contact your Cat dealer for more information.



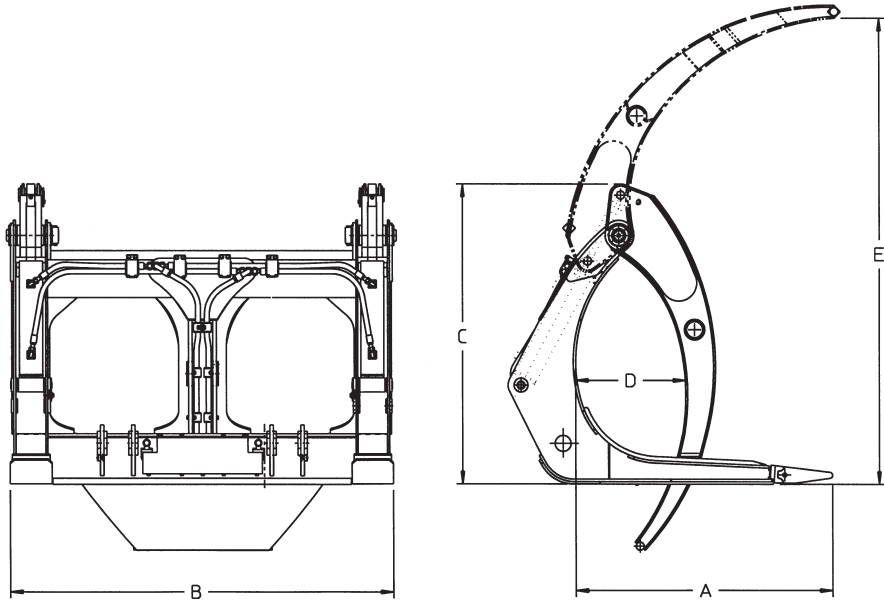

MODEL	980H		980H		988H		988H	
Model Group Number	Double Top Clamp		Millyard Fork		Double Top Clamp		Millyard Top Clamp	
Logging Arrangement	190-3982		192-7656		210-9208		273-3209	
A — Tine Length	1829 mm	6'0"	1830 mm	6'0"	2509 mm	8'3"	2508 mm	8'2"
B — Overall Width	2756 mm	9'2"	2880 mm	9'5"	2774 mm	9'1"	2870 mm	9'5"
C — Back Height	1556 mm	5'1"	—	—	2783 mm	9'2"	—	—
D — Minimum Opening	1828 mm	5'11.95"	694 mm	2'3"	—	—	998 mm	3'3"
E — Maximum Clamp Opening	2990 mm	9'9"	3073 mm	10'1"	3997 mm	13'1"	3911 mm	12'9"
Weight, Approximate	3175 kg	7000 lb	3262 kg	7191 lb	6696 kg	14,760 lb	7428 kg	16,376 lb

NOTE: Third valve required. Counterweight recommended.

Logging forks with millyard style clamps are available where logging application requires clamp to close between tines.

Contact your Cat dealer for more information.

## Features — Couplers

### Fusion Couplers

- Fusion Quick Couplers provide unmatched versatility to any loader. Change tools in seconds without leaving the cab. Any work tool backed by coupler hooks can be picked up; allowing the loader to fit whatever application is at hand.

### Center-Lock Pin Grabber Couplers

- The Cat Center-Lock Pin Grabber Coupler allows buckets and other standard work tools to be used without any modification. Exchanging work tools in seconds improves overall production and increases machine versatility. The Coupler is pinned on in place of the bucket with standard pins, and can be easily removed should the need arise to mount a tool directly to the stick.
- The Center-Lock Coupler offers new possibilities. Buckets can be turned around and used in front shovel mode for final trench clean up. An integral lift eye on the coupler body allows lifting without the weight of the bucket, increasing both machine capacity and visibility from the cab.

## Features — Buckets and Thumbs

### Cat Bucket Thumbs for Hydraulic Excavators

- Multiply the performance of a Cat Excavator by adding a Cat Bucket Thumb. This highly versatile work tool acts in conjunction with the bucket to allow the excavator to grab irregularly shaped items and load loose materials and debris.

### Mini Bucket Thumbs

- Cat Bucket Thumbs are matched to Hydraulic Excavator Buckets for increased on-the-job performance. A thumb works with the bucket to grab, pick and sort debris, brush, trash and rock, opening up new production opportunities for your Cat Mini Excavator. Thumbs are an ideal complement to excavators working in demolition, land clearing, landscaping, material handling and construction jobs.

### Clamshell Buckets

- Clamshell Buckets from Cat are the premier tools for cleanup, demolition, ground clearing and forestry work. Built of heavy T1 steel, these buckets are tough and durable for long service life in the most difficult applications. Clamshell buckets feature continuous 360° rotation, powered by a high-torque hydraulic motor.

- Features
- Specifications

**Features:**

**Buckets, U-blades, Bowldozers, Chip scoops**

- The high-capacity, high-efficiency design of these tools makes them high-production workhorses. They are matched to specific machines and material densities for optimum performance. The extra capacity and load retention capabilities ensure maximum usage and productivity.

<b>WHEEL TRACTOR MODEL</b>	<b>824H</b>		<b>834H</b>	
Blade:				
Capacity	24 m <sup>3</sup>	<b>31.4 yd<sup>3</sup></b>	29.8 m <sup>3</sup>	<b>39 yd<sup>3</sup></b>
Length (cutting width)	4.78 m	<b>15'7"</b>	6.09 m	<b>20'0"</b>
Height	2.24 m	<b>7'4"</b>	2.24 m	<b>7'4"</b>
Wing angle		<b>30°</b>		<b>30°</b>
Weight, Installed (without hydraulics)				
BD (S) Dozer	3630 kg	<b>8000 lb</b>	4627 kg	<b>9470 lb</b>

<b>WHEEL TRACTOR MODEL</b>	<b>814F Series II</b>		<b>824H</b>		<b>834H</b>	
Chip Scoop:						
Lift and Carrying Capacity	15.3 m <sup>3</sup>	<b>20 yd<sup>3</sup></b>	20.6 m <sup>3</sup>	<b>27 yd<sup>3</sup></b>	34.4 m <sup>3</sup>	<b>39.5 yd<sup>3</sup></b>
Dozing Capacity	30.4 m <sup>3</sup>	<b>40 yd<sup>3</sup></b>	41.3 m <sup>3</sup>	<b>54 yd<sup>3</sup></b>	49.4 m <sup>3</sup>	<b>65 yd<sup>3</sup></b>
Width	3.73 m	<b>12'3"</b>	4.03 m	<b>13'3"</b>	4.83 m	<b>15'10"</b>
Height	2.29 m	<b>7'6"</b>	2.79 m	<b>9'2"</b>	2.25 m	<b>7'4"</b>
Depth	2.46 m	<b>8'1"</b>	2.95 m	<b>9'8"</b>	3.02 m	<b>9'11"</b>
Weight	5390 kg	<b>11,880 lb</b>	11 420 kg	<b>19,125 lb</b>	11 105 kg	<b>24,480 lb</b>

**NOTE:** For specifications of Woodchip Dozers used on track-type tractors, see the Bulldozer section in this handbook.

## Features — Rakes

### Loader, Clearing and Clamp and Blade Rakes

- Rakes are durable, high-capacity tools that will increase production for land clearing, site cleanup and site preparation. Available in quick coupler and pin-on models, rakes pile brush, stack and carry debris and load trucks. Features include thick, fabricated teeth, a heavy-duty push bar and serrated tree pusher. A high brush rack retains the load, prevents back spillage and increases carrying capacity.

**USE OF LOG VOLUME TABLES**

The tabulated volumes on these pages were calculated with no taper in log diameter from base to top. Therefore each value listed in the table represents the volume of a true cylinder. In practice this may occur only in short sections of large diameter trees. To obtain the volume of solid wood logs, excluding bark:

1. Establish the base diameter of the log inside the bark and above the butt flare (extreme end taper).
2. Repeat the procedure for the top (small end) of log.
3. Enter log volume table at each of the two established diameters. Move horizontally to the vertical column closest to the length of the log being measured.
4. Establish the volume figures for each end of the log, add the two together and divide by two to obtain average log volume.

**METRIC LOG VOLUMES (in Cubic Meters)**

Log Diameter (cm)	LOG LENGTH (METERS)														
	2	4	6	8	10	12	14	16	18	20	22	24	26	28	30
10	0.016	0.031	0.047	0.063	0.078	0.094	0.12	0.13	0.14	0.16	0.17	0.19	0.20	0.22	0.24
15	0.035	0.071	0.11	0.14	0.18	0.21	0.25	0.28	0.32	0.35	0.39	0.42	0.46	0.49	0.53
20	0.06	0.13	0.19	0.25	0.31	0.38	0.44	0.50	0.57	0.63	0.69	0.75	0.82	0.86	0.94
25	0.10	0.20	0.30	0.39	0.49	0.59	0.69	0.79	0.88	0.98	1.08	1.18	1.28	1.37	1.47
30	0.14	0.28	0.42	0.57	0.71	0.85	0.99	1.13	1.27	1.42	1.56	1.70	1.84	1.98	2.12
35	0.19	0.38	0.58	0.7	0.96	1.15	1.35	1.54	1.73	1.93	2.12	2.31	2.50	2.69	2.89
40	0.25	0.50	0.75	1.01	1.26	1.51	1.77	2.02	2.27	2.52	2.78	3.02	3.27	3.51	3.77
45	0.32	0.64	0.95	1.27	1.59	1.91	2.22	2.54	2.86	3.18	3.50	3.82	4.13	4.45	4.77
50	0.39	0.79	1.18	1.57	1.96	2.36	2.76	3.16	3.54	3.94	4.34	4.71	5.10	5.49	5.89
55	0.48	0.95	1.43	1.90	2.38	2.85	3.33	3.80	4.28	4.75	5.23	5.70	6.18	6.65	7.12
60	0.57	1.13	1.70	2.26	2.83	3.39	3.96	4.52	5.09	5.65	6.22	6.78	7.35	7.92	8.48
65	0.66	1.33	1.99	2.65	3.32	3.98	4.65	5.31	5.98	6.64	7.30	7.96	8.62	9.29	9.95
70	0.77	1.54	2.31	3.08	3.85	4.62	5.40	6.15	6.93	7.70	8.48	9.23	10.0	10.77	11.54
75	0.88	1.77	2.65	3.53	4.42	5.30	6.19	7.06	7.95	8.84	9.72	10.60	11.49	12.37	13.25
80	1.01	2.01	3.02	4.02	5.03	6.03	7.05	8.06	9.07	10.08	11.09	12.10	13.10	14.10	15.10
85	1.13	2.27	3.40	4.54	5.67	6.81	7.94	9.08	10.20	11.32	12.47	13.62	14.75	15.89	17.02
90	1.27	2.54	3.82	5.09	6.36	7.63	8.90	10.17	11.43	12.71	13.99	15.27	16.54	17.81	19.10
95	1.42	2.84	4.75	5.67	7.09	8.51	9.92	11.33	12.76	14.18	15.60	17.01	18.43	19.85	21.26
100	1.57	3.14	4.71	6.28	7.85	9.42	11.0	12.58	14.16	15.72	17.30	18.85	20.42	22.0	23.56
125	2.45	4.90	7.36	9.82	12.27	14.73	17.18	19.6	22.1	24.5	27.0	29.5	32.0	34.4	36.8
150	3.53	7.1	10.6	14.1	17.7	21.2	24.7	28.3	31.8	35.3	38.8	42.4	45.9	49.5	53.0
175	4.8	9.6	14.5	19.2	24.0	28.9	33.7	38.5	43.3	48.1	53.0	57.7	62.6	67.3	72.2
200	6.3	12.6	18.8	25.1	31.4	37.7	44.0	50.3	56.5	62.8	69.1	75.4	81.7	88.0	94.2

**ENGLISH MEASURE LOG VOLUMES (in Cubic Feet)**

Log Diameter (inches)	LOG LENGTH (FEET)																	
	8	12	16	20	24	28	32	36	40	44	48	52	56	60	70	80	90	100
4	0.7	1	1.4	1.7	2.1	2.4	2.8	3.1	3.5	3.8	4.2	4.5	4.9	5.2	6.1	7	7.8	8.7
6	1.6	2.4	3.1	3.9	4.7	5.5	6.3	7.1	7.8	8.6	9.4	10	11	12	13	16	18	20
8	2.8	4.2	5.6	7	8.4	9.8	11	13	14	15	17	18	19	21	24	28	31	35
10	4.4	6.5	8.7	11	13	15	17	20	22	24	26	28	31	33	38	44	49	55
12	6.3	9.4	13	16	19	22	25	28	31	35	38	41	44	47	55	63	71	79
14	8.5	13	17	21	26	30	34	39	43	47	51	56	60	64	74	86	96	101
16	11	17	22	28	34	39	45	50	56	61	67	73	78	84	98	112	126	140
18	14	21	28	35	42	49	57	64	71	78	85	92	99	106	124	141	159	177
20	17	26	35	44	52	61	70	79	87	96	105	113	122	131	153	175	196	218
22	21	32	42	53	63	74	85	95	106	116	127	137	148	158	185	211	238	264
24	25	38	50	63	75	88	101	113	126	138	151	163	176	189	220	251	283	314
26	29	44	59	74	89	103	118	133	147	162	177	192	207	221	258	295	332	369
28	34	51	68	86	103	120	137	154	171	188	205	222	240	256	299	342	385	428
30	39	59	79	98	118	137	157	177	196	216	236	255	275	295	344	393	442	491
32	45	67	89	118	134	156	179	201	223	246	268	290	313	335	391	447	503	559
34	50	76	101	126	151	177	202	227	252	277	303	328	353	378	441	504	567	631
36	57	85	113	141	170	198	226	255	282	311	339	368	396	424	495	566	637	707
38	63	95	126	158	189	220	252	284	315	347	378	410	441	473	551	630	709	788
40	70	105	140	175	210	244	279	314	349	384	419	454	489	524	611	698	785	873
50	109	164	218	273	327	382	436	491	545	600	645	709	764	818	955	1091	1227	1364
60	157	234	314	393	471	550	628	707	785	864	943	1021	1100	1178	1374	1571	1767	1964
70	214	321	428	535	642	748	855	962	1069	1176	1283	1389	1497	1604	1871	2138	2405	2673
80	279	420	559	698	838	977	1117	1257	1396	1536	1676	1815	1955	2095	2441	2293	3142	3491

**WEIGHTS OF COMMERCIALY IMPORTANT WOODS**

Species	kg/m <sup>3</sup> (Green)	lb/ft <sup>3</sup> (Green)	Species	kg/m <sup>3</sup> (Green)	lb/ft <sup>3</sup> (Green)
<b>A. Temperate Zone*</b>			Maple, Big Leaf	753	47
Alder, Red	737	46	Black	865	54
Ash, White	769	48	Red	801	50
Aspen	689	43	Silver	721	45
Baldcypress	817	51	Sugar	897	56
Basswood	673	42	Oak, Black	1009	63
Beech	865	54	Chestnut	977	61
Birch, Paper	801	50	Red	1009	63
Yellow	929	58	Red, Swamp	1073	67
Cedar, Alaska	577	36	Swamp Chestnut	1041	65
Incense	721	45	White	993	62
Northern, White	449	28	White, Swamp	1105	69
Port-Orford	897	56	Pine, Jack	801	50
Western Red	433	27	Loblolly	993	62
Cherry, Black	721	45	Lodgepole	625	39
Cottonwood, Eastern	785	49	Long Leaf	993	62
Douglas Fir, (Coast)	881	55	Norway (Red)	673	42
(Inland Empire)	577	36	Short Leaf	993	62
Elm, American	865	54	Slash	993	62
Fir, Alpine	449	28	Sugar	817	51
Balsam	721	45	Western Yellow, (Ponderosa)	721	45
Nobel	481	30	White (Western)	561	35
Red	769	48	White (Eastern)	577	36
Silver	577	36	Poplar, Yellow	609	38
White	753	47	Redwood	801	50
Gum, Black	721	45	Spruce, Black	513	32
Blue	1121	70	Engleman	625	39
Red	801	50	Red	545	34
Tupelo	897	56	Sitka	529	33
Hemlock, Eastern	801	50	White	545	34
Western	961	60	Sweetgum	801	50
Hickory, Pecan	993	62	Sycamore	833	52
True	1009	62	Tamarack	753	47
Larch, Western	769	48	Walnut, Black	929	58
Locust, Black	929	58	Willow, Black	801	50
Magnolia, Cucumber	785	49			

\*NOTE: Weights taken from U.S. Dept. of Agriculture handbook No. 72, Wood Handbook.

Weights of Commercially Important Woods  
 ● Southeast Asia  
 ● West Africa

Forest Products  
 Tables

Species	kg/m <sup>3</sup> (Green)	lb/ft <sup>3</sup> (Green)
<b>B. Southeast Asia</b>		
Apitong	961	60
Bintangor	865	54
Chumprak	929	58
Ebony	1746	109
Geronggang	721	45
Jelutong	641	40
Kapur (Borneo Camphorwood)	1073	67
Keruing	1121	70
Krabak	817	51
Kruen	1121	70
Lumbayau	929	58
Mahogany, Philippine		
(Red Luan)	753	47
(White Luan)	769	48
(Yellow Luan)	769	48
Mahoni	913	57
Alayan Kauri (Damar Minyak)	817	51
Melantai	705	44
Melapi	849	53
Mangkulang	929	58
Meranti Bakau	849	53
Meranti, Dark Red	753	47
White	769	48
Yellow	769	48
Mersawa	817	51
Nyatoh	897	56
Palosapis	817	51
Pulai	545	34
Ramin	1073	67
Rosewood (Sonokelina)	1314	82
Seraya, Dark Red	753	47
Yellow	769	48
White	769	48
Teak	1073	67

Species	kg/m <sup>3</sup> (Green)	lb/ft <sup>3</sup> (Green)
<b>C. West Africa</b>		
Abura	850	53.06
Ako	800	49.94
Azobe	1300	81.16
Aniegre (Mukali)	950	59.31
Bete	900	56.19
Bosse	900	56.19
Bubinga	1000	62.43
Dibetau	750	46.82
Douka (Makore)	950	59.31
Doussie	1200	74.91
Framire	850	53.06
Fromager	550	34.34
Ilomba	750	46.82
Iroko	1200	74.91
Kokrodua (Afromosia)	1000	62.43
Kosipo	900	56.19
Limba	750	46.82
Mahogany	750	46.82
Moabi	1100	68.67
Niangon	900	56.19
Okoume	650	40.57
Ozigo	900	56.19
Padouk	1000	62.43
Samba (Obeche)	650	40.58
Sapelli	900	56.19
Sipo	800	49.94
Tchitola	850	53.06
Tiaba	900	56.19
Tola	850	53.06



## Forest Products Tables

### Weights of Commercially Important Woods

- Australia
- New Zealand
- Papua New Guinea

Species	kg/m <sup>3</sup> (Green)	lb/ft <sup>3</sup> (Green)
<b>D. Australia</b>		
Ash Alpine .....	1041	65
Mountain .....	1009	63
Silvertop .....	1330	83
Black Butt .....	1121	70
Box Long Leaf .....	993	62
Yellow .....	1105	69
Black .....	1105	69
Brownbarrel .....	1073	67
Candle Bark .....	657	41
Gum Grey .....	1217	76
Manna .....	1121	70
Mountain .....	1169	73
Mountain Grey .....	1057	66
River Red .....	1137	71
Forest Red .....	1201	75
Southern Blue .....	1217	76
Spotted .....	1201	75
Sydney Blue .....	1153	72
Iron Bark Gray .....	1330	83
Narrowleaved .....	1330	83
Red .....	1330	83
Jarrah .....	1169	73
Karri .....	1169	73
Mahogany Red .....	1153	72
White .....	1282	80
Myrtle .....	1169	73
Peppermint .....	1120	70
Pine Radiata .....	865	54
Monerey .....	865	54
Celerytop .....	1057	66
Stringy Bark Brown .....	1233	77
Messmate .....	1169	73
Yellow .....	1217	76
White .....	1121	70
Tallowwood .....	1201	75
Wandoo .....	1282	80

Species	kg/m <sup>3</sup> (Green)	lb/ft <sup>3</sup> (Green)
<b>E. New Zealand</b>		
Exotic Softwoods		
Radiata Pine .....	1000	62
Douglas Fir .....	734	45
Corsican Pine .....	985	61
Redwood .....	1016	63
Larch .....	960	60
Indigenous Softwoods		
Mati .....	1120	70
Rimu .....	1130	70
Exotic Hardwoods		
Eucaliptus Botryoides .....	893	56
Eucaliptus Saligna .....	1200	75
Indigenous Hardwoods		
Beech — Silver .....	920	57
Beech — Red .....	1200	75
Tawa .....	1022	64

Species	kg/m <sup>3</sup> (Green)	lb/ft <sup>3</sup> (Green)
<b>F. Papua New Guinea</b>		
Pine, Hoop .....	520	32
Kauri .....	480	30
Klinki .....	510	31
Kwila .....	800	50
Erima .....	390	24
Taun .....	680	42
Walnut, PNG .....	560	35
Cedar, Pencil .....	720	50
Mersawa .....	650	40
Celtis, Hard .....	780	48
Rosewood, PNG .....	600	37
Beech, PNG .....	830	51
Oak, PNG .....	650	40
Ebony, PNG Black .....	1115	69
PNG White .....	720	50
Hardwood, Yellow .....	780	48
Hopea, Heavy .....	960	60
Light .....	710	44
Podocarp, Black .....	410	25
Terminalia, Brown .....	450	28

**ESTIMATING NUMBER OF TREES PER HECTARE**

		Spacing (Meters)							
Spacing (Meters)	1	2	3	4	5	6	7	8	
1	10 000	5000	3333	2500	2000	1667	1428	1250	
2	5000	2500	1667	1250	1000	834	714	625	
3	3333	1667	1111	834	667	556	477	417	
4	2500	1250	834	625	500	417	357	313	
5	2000	1000	667	500	400	330	286	250	
6	1667	834	556	417	333	278	238	208	
7	1428	714	477	357	286	238	204	179	
8	1250	625	417	313	250	208	179	156	

**ESTIMATING NUMBER OF TREES PER ACRE**

		Spacing (Feet)							
Spacing (Feet)	5	6	7	8	9	10	11	12	
5	1742	1452	1244	1089	968	871	792	726	
6	1452	1210	1037	907	806	726	660	605	
7	1244	1037	888	777	691	622	565	518	
8	1089	907	777	680	605	544	495	453	
9	968	806	691	605	537	484	440	403	
10	871	726	622	544	484	435	396	363	
11	792	660	565	495	440	396	360	330	
12	726	605	518	453	403	363	330	302	
13	671	558	478	418	372	335	304	279	
14	622	518	444	390	346	311	283	259	
15	580	484	415	363	323	290	264	242	

**COMPARISON OF LOG RULES** • Board Foot Values for 16-Foot Logs

Diameter at Small End, Inside Bark, Inches	International 1/4 Inch	Scribner	Scribner Decimal	Spaulding	Doyle
4	5	10	10	—	—
6	20	18	20	—	4
8	40	32	30	—	16
10	65	54	60	50	36
12	95	79	80	77	64
14	135	114	110	114	100
16	180	159	160	161	144
18	230	213	210	216	196
20	290	280	280	276	256
22	355	334	330	341	324
24	425	404	400	412	400
26	500	500	500	488	484
28	585	582	580	569	576
30	675	657	660	656	676
32	770	736	740	748	784
34	875	800	800	845	900
36	980	923	920	950	1024
38	1095	1068	1070	1064	1156
40	1220	1204	1200	1185	1296

**UNIT OF MEASUREMENT DEFINITIONS**

1 board foot	= 1/12 ft <sup>3</sup> of solid wood (1' × 1' × 1")
1000 board feet	= 83.33 ft <sup>3</sup> of solid wood
1 c. unit of wood	= 100 solid ft <sup>3</sup> = 1200 board feet = 2.83 <sup>3</sup>
1 cord of wood	= 128 ft <sup>3</sup> of stacked logs = 3.62 m <sup>3</sup>
1 unit of wood	= 200 ft <sup>3</sup> of loose chips = 5.66 m <sup>3</sup>
1 cord of wood	= 0.85 units
1 Hoppus Ton	= 50 ft <sup>3</sup> (assumed) = 63.65 ft <sup>3</sup> (actual) = 600 board feet = 763.8 BF Brereton = 1.8 m <sup>3</sup> actual = 1.4 m <sup>3</sup> assumed
1 cubic meter	= 35.32 ft <sup>3</sup> = 424 board feet = 333 board feet Hoppus tons = 0.555 Hoppus Tons
1 MBF Brereton	= 2.36 m <sup>3</sup> = 785.4 board feet Hoppus
1 MBF Hoppus MBF	= 1273 board feet-Brereton = Thousand board feet
1 Super Foot	= 1 board foot
100 Super Feet	= 1000 board foot = 0.236 m <sup>3</sup>
600 Super Feet	= 50 ft <sup>3</sup>
1 lb/ft <sup>3</sup>	= 16.0185 kg/m <sup>3</sup>

**CUBIC FEET OF SOLID WOOD PER CORD**

Length of Sticks-Ft.	Diameter at Small End		
	1"-2.5"	2.5"-5.5"	Over 5.5"
2	65	84	91
4	64	82	89
8	59	77	84
12	54	71	78

**RULE OF THUMB CONVERSIONS**

1 c. unit of wood = 1.117 cords = 1.25 units of chips = 250 ft <sup>3</sup> of chips = 7.08 m <sup>3</sup>
1 cord of wood = 85 ft <sup>3</sup> of solid wood = 1.06 units of chips = 2.41 m <sup>3</sup>
1 unit of chips = 80 ft <sup>3</sup> of solid wood = 2.27 m <sup>3</sup>
1 cord of wood = 500 board feet = 1.18 m <sup>3</sup>
2000 pounds of chips = 500 pounds of pulp
1 cord = 212 ft <sup>3</sup> of chips = 6 m <sup>3</sup>

# PIPELAYERS

## CONTENTS

Features	7-1
Specifications	7-2
Lifting Capacities	7-4
Drawbar Pull Charts	7-6
Travel and Hook Speeds	7-7
Application	7-8
Extreme Slope Operation	1-27

## Features:

- **Hydrostatic transmission** on PL61.
- **Planetary power shift** transmission on 572R2, 583T, 587R, and 587T models.
- **Kick-out helps prevent boom bending** as boom approaches near-vertical.
- **Sealed and Lubricated Track.**
- **Simplified Controls** for all functions including raise, lower, quick-drop and power down, high and low range and speed adjustments.
- **Modular design of major components and accessory drive system** for simplified repair.
- **Separate, self-energizing brakes** for boom and hook winches.
- **Positive track pin retention** (583T, 587R, and 587T).
- **Hydraulic Drawworks** with two independently driven hydraulic motors for boom and hook winches.



MODEL	PL61		572R Series 2		583T		
Flywheel Power	92 kW	125 hp	179 kW	240 hp	231 kW	310 hp	
Operating Weight (with full fuel tank and operator)	17 000 kg	37,480 lb	31 845 kg	70,206 lb	45 359 kg	100,000 lb	
Engine Model	C6.6 ACERT		3176C		C15 ACERT		
Rated Engine RPM	2100		2100		1850		
No. of Cylinders	6		6		6		
Displacement	6.6 L	403 in <sup>3</sup>	10.3 L	629 in <sup>3</sup>	15.2 L	928 in <sup>3</sup>	
Lift Capacity at 1.22 m (4'0") Overhang	18 145 kg	40,000 lb	40 800 kg	90,000 lb	63 504 kg	140,000 lb	
Standard Boom Length	5.49 m	18'0"	6.1 m	20'0"	7.3 m	24'0"	
Width of Standard Shoe	560 mm	22"	660 mm	26"	710 mm	28"	
Length of Track on Ground	2645 mm	8'8"	3.176 m	10'5"	3.556 m	11'8"	
Ground Contact Area (with standard shoes)	3 m <sup>2</sup>	4650 in <sup>2</sup>	4.19 m <sup>2</sup>	6500 in <sup>2</sup>	5.10 m <sup>2</sup>	7896 in <sup>2</sup>	
Track Gauge	2 m	6'7"	2.235 m	7'4"	2.34 m	7'8"	
Fuel Tank Refill Capacity	295 L	78 U.S. gal	479 L	127 U.S. gal	409 L	108 U.S. gal	
GENERAL DIMENSIONS:							
Height to Top of Stack	2.91 m	9'7"	3.18 m	10'5"	3.454 m	11'4"	
Height to Top of Counterweight or Winch	2.45 m	8'1"	2.9 m	9'6"	3.505 m	11'6"	
Height with ROPS (boom removed)	2958 mm	9'8.5"	3454 mm	11'4"	3728 mm	12'3"	
Width, Weights Retracted	3 m	9'10"	3.66 m	12'0"	3.73 m	12'3"	
Minimum Shipping Width (both side frames removed)	2560 mm	8'5"	2.895 m	9'6"	3.07 m**	10'1"***	
Shipping Width (left frame removed)	2816 mm	9'3"	3.66 m	12'0"	3.61 m*	11'10"*	
Overall Length	3.78 m	12'5"	4.74 m	15'6"	5.23 m	17'2"	
Ground Clearance	360 mm	14"	416 mm	16.4"	470 mm	18.5"	
DRUMS and CABLES:							
Drum Capacity	Load	73 m	239'	80 m	263'	181 m	594'
	Boom	49.4 m	162'	52 m	170'	181 m	594'
Cable Diameter	Load	16 mm	0.62"	19 mm	0.75"	19 mm	0.75"
	Boom	16 mm	0.62"	19 mm	0.75"	19 mm	0.75"
Drum Diameter	Load	216 mm	8.5"	254 mm	10"	317 mm	12.5"
	Boom	245 mm	9.63"	224 mm	8.5"	317 mm	12.5"
Adjustable Counterweights		7 @		2 @		2 @	
		67.7 kg ea	149 lb ea	370 kg ea	815 lb ea	300 kg ea	662 lb ea
		9 @		7 @		5 @	
		114.8 kg ea	253 lb ea	479 kg ea	1055 lb ea	430 kg ea	948 lb ea
						6 @	
						535 kg ea	1180 lb ea
						9036 kg	19,920 lb
Total Weight Extendable	1231 kg	2714 lb	5073 kg	11,184 lb			
	LGP Option						
Operating Weight 610 mm (24")	17 800 kg	39,242 lb					
Shipping Width:							
Boom Removed	3200 mm	10'6"					
Counterweight Removed	3116 mm	10'3"					
Frame, Brackets, Winches Removed	2760 mm	9'1"					
Track Shoe Width	610 mm	24"					
	760 mm	30"					
Ground Contact Area:							
610 mm (24") Shoes	3.2 m <sup>2</sup>	4690 in <sup>2</sup>					
760 mm (30") Shoes	4 m <sup>2</sup>	6200 in <sup>2</sup>					

\*Boom and counterweight only removed.

\*\*Counterweight frame, counterweight mounting brackets, boom, and boom mounting brackets removed.



**MODEL**

**587R**

**587T**

Flywheel Power	262 kW	351 hp	273 kW	366 hp
Operating Weight (with full fuel tank and operator)	53 442 kg	117,820 lb	53 070 kg	117,000 lb
Engine Model	<b>3406C DITA</b>		<b>C15 ACERT</b>	
Rated Engine RPM	<b>1900</b>		<b>1800</b>	
No. of Cylinders	<b>6</b>		<b>6</b>	
Displacement	14.6 L	<b>893 in<sup>3</sup></b>	15.2 L	<b>928 in<sup>3</sup></b>
Lift Capacity at 1.22 m (4'0") Overhang	91 625 kg	<b>202,000 lb</b>	91 625 kg	<b>202,000 lb</b>
Standard Boom Length	8.5 m	<b>28'0"</b>	8.5 m	<b>28'0"</b>
Width of Standard Shoe	864 mm	<b>34"</b>	864 mm	<b>34"</b>
Length of Track on Ground	3.587 m	<b>11'9"</b>	3.587 m	<b>11'9"</b>
Ground Contact Area (with standard shoes)	6.2 m <sup>2</sup>	<b>9613 in<sup>2</sup></b>	6.2 m <sup>2</sup>	<b>9613 in<sup>2</sup></b>
Track Gauge	2.54 m	<b>8'4"</b>	2.54 m	<b>8'4"</b>
Fuel Tank Refill Capacity	568 L	<b>150 U.S. gal</b>	568 L	<b>150 U.S. gal</b>
<b>GENERAL DIMENSIONS:</b>				
Height to Top of Counterweight or Winch	3.505 m	<b>11'6"</b>	3.505 m	<b>11'6"</b>
Height with ROPS (boom removed)	—		3835 mm	<b>12'7"</b>
Width, Weights Retracted	4.343 m	<b>14'3"</b>	4.343 m	<b>14'3"</b>
Minimum Shipping Width	3.860 m*	<b>12'8"</b> *	3.860 m*	<b>12'8"</b> *
Shipping Width (boom and counterweight removed)	4.038 m	<b>13'3"</b>	4.038 m	<b>13'3"</b>
Overall Length	5.486 m	<b>18'0"</b>	5.486 m	<b>18'0"</b>
Ground Clearance	457 mm	<b>18"</b>	457 mm	<b>18"</b>
<b>DRUMS and CABLES:</b>				
Drum Capacity	Load	181 m	181 m	594'
	Boom	181 m	181 m	594'
Cable Diameter	Load	19 mm	19 mm	0.75"
	Boom	19 mm	19 mm	0.75"
Drum Diameter	Load	317 mm	317 mm	12.5"
	Boom	317 mm	317 mm	12.5"
Adjustable Counterweights		<b>2 @</b>	<b>2 @</b>	
	285 kg	<b>628 lb</b>	285 kg	<b>628 lb</b>
	640 kg	<b>1410 lb</b>	640 kg	<b>1410 lb</b>
Total Weight Extendable		<b>7 @</b>	<b>7 @</b>	
	714 kg	<b>1574 lb</b>	714 kg	<b>1574 lb</b>
	12 900 kg	<b>28,440 lb</b>	12 900 kg	<b>28,440 lb</b>

7

\*Counterweight frame, counterweight mounting brackets, and boom removed.

**PL61**

LIFTING CAPACITY\* 5.49 m (18'0") BOOM

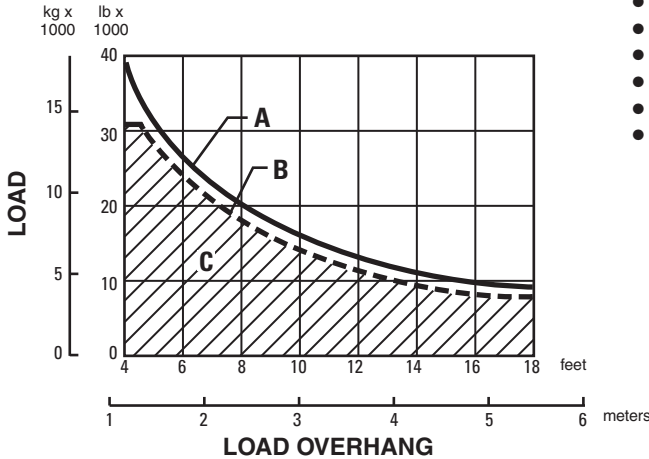

**\*Specified Equipment:**

- 16 mm (5/8") diameter wire rope.
- 183.3 kN (41,200 lb) minimum breaking strength.
- 3 part load line.
- 3 part boom line.
- 1231 kg (2714 lb) counterweight extended.
- Standard 5.49 m (18'0") Boom.
- Total operating weight  
Narrow — 17 000 kg (37,480 lb).  
LGP — 17 800 kg (39,242).

KEY

- A — Lift capacity at tipping point per ISO 8813
- B — Rated load capacity per ANSI/ASME B30.14
- C — Working range per ANSI/ASME B30.14

**572R Series 2**

LIFTING CAPACITY\* 6.1 m or 7.3 m (20'0" or 24'0") BOOMS

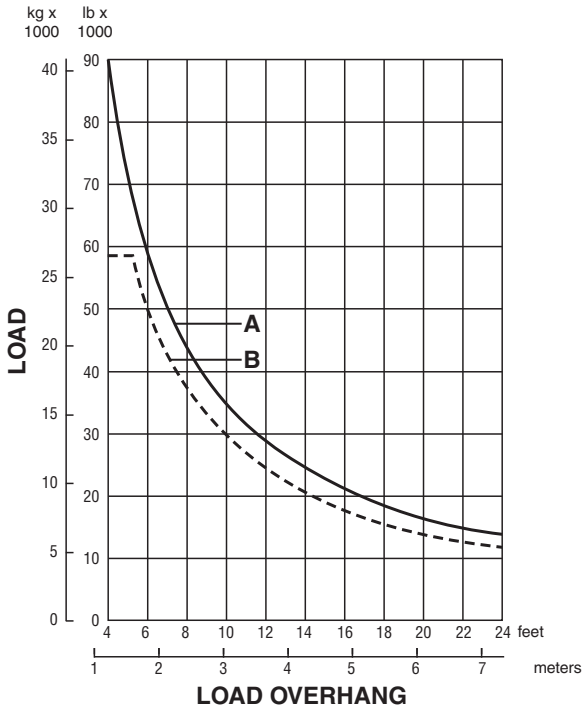

**\*Specified Equipment:**

- 19 mm (3/4") dia. wire rope 261.66 kN (58,800 lb) minimum breaking strength.
- 4 part load line.
- 4 part boom line.
- 5073 kg (11,184 lb) counterweight extended.
- Standard 6.1 m (20'0") Boom.

KEY

- A — Max lift
- B — Rated lift

**NOTE:** ISO stands for the International Standards Organization. ANSI stands for American National Standard Institute.

**583T**

**LIFTING CAPACITY\* 7.3 m, 8.5 m (24'0", 28'0") BOOMS**

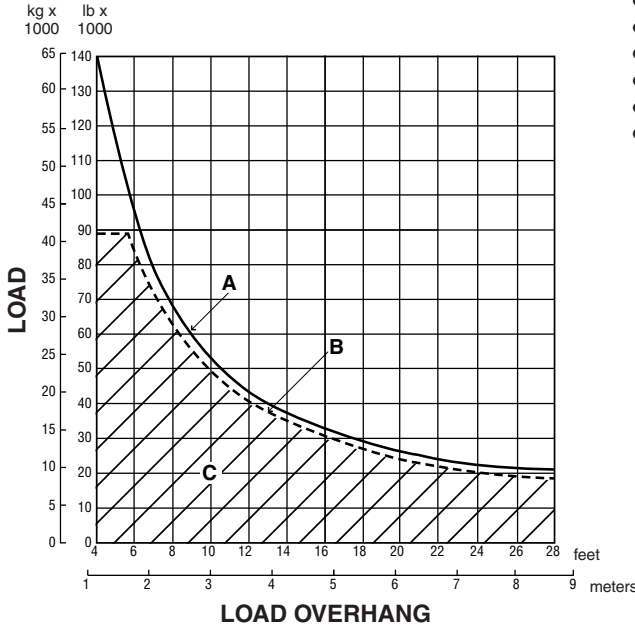

**\*Specified Equipment:**

- 19 mm (3/4") diameter wire rope.
- 26 672 kg (58,800 lb) minimum breaking strength.
- 6 part load line.
- 5 part boom line.
- 9036 kg (19,920 lb) counterweight extended.
- Standard 7.3 m (24'0") Boom.
- Total operating weight 45 359 kg (100,000 lb).

**KEY**

- A — Max lift capacity per ISO 8813
- B — Rated load per ANSI/ASME B30.14
- C — Working range per ANSI/ASME B30.14

**587R/T**

**LIFTING CAPACITY\* 8.5 m (28'0") BOOM**

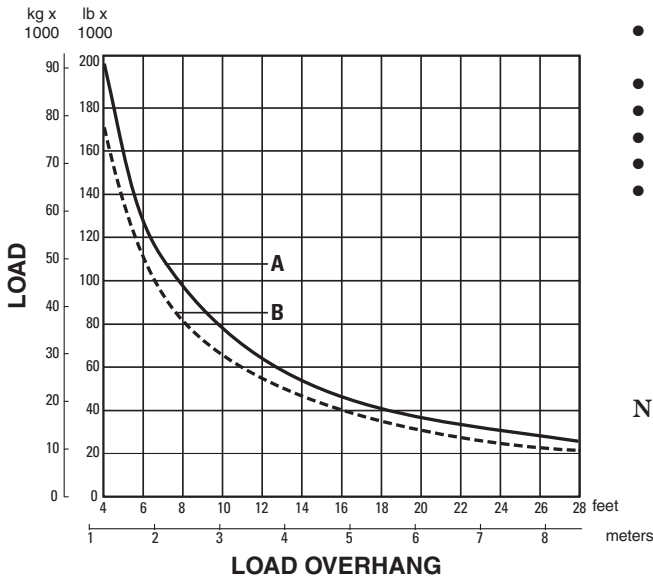

**\*Specified Equipment:**

- Load: 19 mm (3/4") dia. wire rope 26 672 kg (58,800 lb) minimum breaking strength.
- Boom: 19 mm (3/4") dia. wire rope 26 672 kg (58,800 lb) minimum breaking strength.
- 8 part load line.
- 5 part boom line.
- 12 900 kg (28,440 lb) counterweight extended.
- Standard 8.5 m (28'0") Boom.
- Total operating weight 53 070 kg (117,000 lb).

**KEY**

- A — Max lift
- B — Rated lift

**NOTE:** ISO stands for the International Standards Organization. ANSI stands for American National Standard Institute.



**PL61**

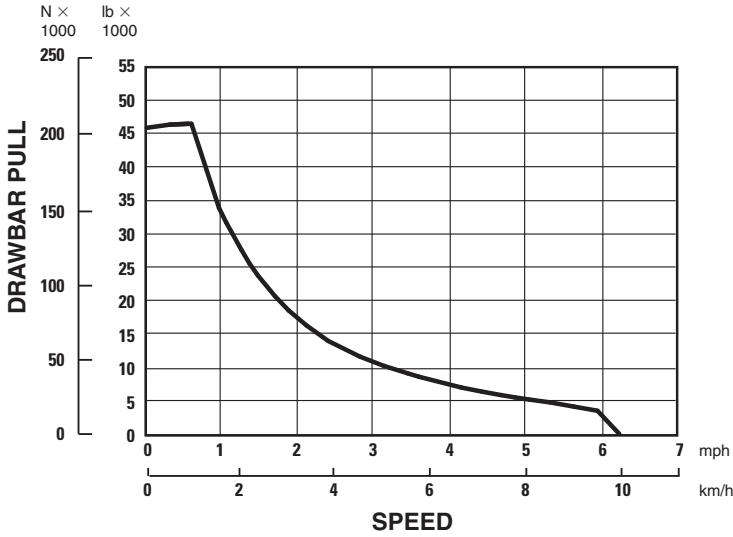

**NOTE:** Usable pull will depend upon weight and traction of equipped tractor.

**572R Series 2**

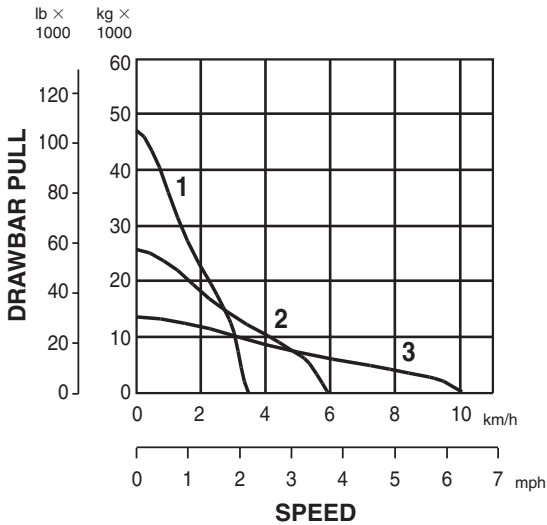

**583T**

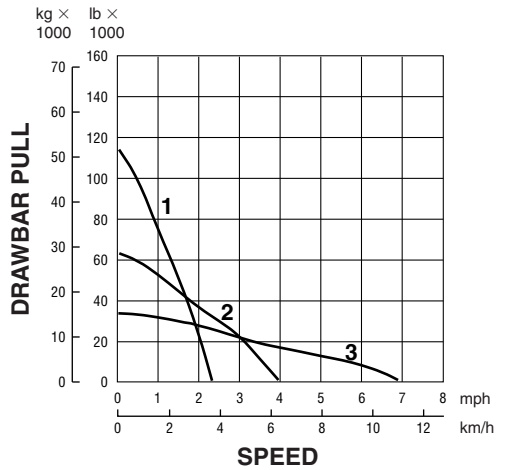

**KEY**  
 1 — 1st Gear  
 2 — 2nd Gear  
 3 — 3rd Gear

MODEL	PL61				572R Series 2			
	Forward		Reverse		Forward		Reverse	
Travel Speeds (at rated RPM)	km/h	mph	km/h	mph	km/h	mph	km/h	mph
1st Gear .....	3.1	1.9	3.8	2.3	3.5	2.2	4.5	2.8
2nd Gear .....	5.4	3.3	6.7	4.1	6.1	3.8	7.9	4.9
3rd Gear .....	10.0	6.2	10.0	6.2	10.6	6.6	13.5	8.4
Hydrostatic .....	10.0	6.2	10.0	6.2	—	—	—	—

MODEL	583T				587R				587T			
	Forward		Reverse		Forward		Reverse		Forward		Reverse	
Travel Speeds (at rated RPM)	km/h	mph	km/h	mph	km/h	mph	km/h	mph	km/h	mph	km/h	mph
1st Gear .....	3.5	2.3	4.7	2.9	3.2	2.0	4.3	2.7	3.2	2.0	4.3	2.7
2nd Gear .....	6.4	4.0	8.1	5.0	5.6	3.5	7.4	4.6	5.8	3.6	7.6	4.7
3rd Gear .....	10.8	6.8	13.8	8.6	9.7	6.0	12.6	7.8	10.0	6.2	12.9	8.0

7

MODEL	PL61		572R Series 2	
	m/min	ft/min	m/min	ft/min
Pipelayer Hook Speeds per minute, Bare drum at rated engine RPM				
Low Raise & Lower .....	33.0	108	11.0	37
Hi Raise & Lower .....	69.5	228	22.0	72

MODEL	583T		587R/T	
	m/min	ft/min	m/min	ft/min
Pipelayer Hook Speeds per minute, Bare drum at rated engine RPM				
Low Raise .....	26.0	85	—	—
Low Lower .....	22.0	73	15.5	50.8
Hi Lower .....	30.0	98	15.5	50.8

**PIPELAYER APPLICATION CALCULATIONS:**

**Typical pipelayer applications on flat, firm underfoot conditions**

- PL61** laying 8" to 16" pipe
- 572R2** laying 16" to 24" pipe
- 583T** laying 24" to 36" pipe
- 587R/T** laying 36" to 56" pipe

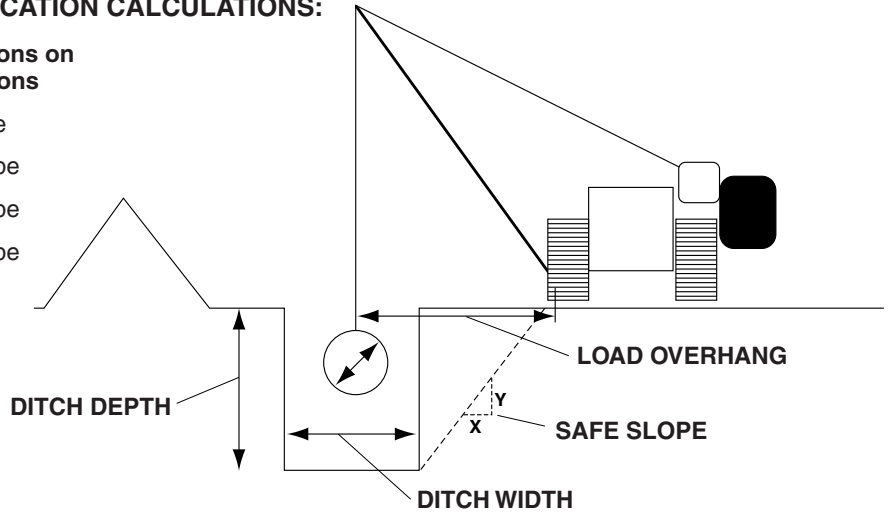

The chart above provides general information representing typical pipelayer applications. While the following scenario explores many of the variables involved in pipelaying it does not cover all the possible variables that must be considered by pipelaying contractors.

When sizing pipelayers for an application there are many considerations other than the machine's SAE rated lift capacity. These include but are not limited to:

- pipe diameter and weight per linear foot
- ditch width and depth
  - ditch width is typically  $2 \times$  pipe diameter
  - ditch depth is typically  $>2.5 \times$  pipe diameter
- distance from the ditch (safe slope) required by soil stability conditions
  - typically 2:1 (meaning the pipelayer must be  $2 \times$  ditch depth from the ditch edge)

- acceptable distance between pipe lifting points while suspended (to prevent bending)
  - determined by the pipe's bending characteristics. If the lifting points are too far apart a pipe can sag enough due to its own weight that it will damage itself.
- the operating safety factor desired by the contractor
- the length of pipe that will need to be suspended while laying-in
  - determined by pipe bending characteristics, terrain, etc.
- ground conditions, road bed preparation

An important consideration is the necessary load overhang. This is the distance from the center of the pipe to the tractor's left track rail. The load overhang required for an application can be estimated by:

- load overhang = safe slope × ditch depth + (0.5 × ditch width)

The pipelayer's rated load capacity at a specific load overhang (per ANSI/ASME B30.14) can be found in the load capacity graphs in this section of the performance handbook. Once the load capacity is determined the maximum lift point spacing can be estimated by:

- max lift point spacing =  $\frac{\text{load capacity at load overhang}}{\text{safety factor} \times \text{pipe weight per linear foot}}$

The maximum distance between pipe lift points (based on pipe bending characteristics) may be a shorter distance than the maximum spacing between lift points as calculated based on pipelayer load capacity. If this is the case, then in order to avoid damaging the pipe, the shorter distance should be considered to be the maximum distance between pipelayers.

As an example, consider a project involving 0.5" wall 24" diameter pipe which has a weight per linear foot of 125.5 lb and the soil has a safe slope of 2. Using the above formulas:

- the ditch depth would be  $3 \times 2 \text{ ft} = 6 \text{ ft}$  deep
- the ditch width would be  $2 \times 2 \text{ ft} = 4 \text{ ft}$
- the load overhang would be  $2 \times 6 \text{ ft} + (0.5 \times 4 \text{ ft}) = 14 \text{ ft}$

Using the 572R Series 2's lift capacity chart we find that the 572R Series 2 has an ANSI rated load capacity of approximately 21,250 lb at a 14 ft load overhang.

When using rated load numbers it is important to understand that the lift capacity charts are based on SAE and ANSI test procedures that rate pipelayers on level, concrete surfaces. Working on softer underfoot conditions, working on slopes, (and other) can greatly reduce the pipelayer's load capacity.

If the contractor employs a safety factor of 2 then the maximum spacing between pipe lift points is:

$$\frac{21,250 \text{ lb}}{2 \times 125.5 \text{ lb/ft}} = 84.7 \text{ ft}$$

It is important to remember that this is the distance between the lift points, not the distance nose-to-tail between pipelayers. For this example, assume that 500 ft of pipe must be suspended during the laying-in process.

$$\frac{500 \text{ ft}}{84.7 \text{ ft per pipelayer}} = 5.9 \text{ which means that six pipelayers are needed}$$

The number of pipelayers required could also be determined by a second method:

$$\frac{\text{ft of pipe suspended} \times \text{pipe weight per ft} \times \text{safety factor}}{\text{rated load at overhang}}$$

In this case:

$$\frac{500 \text{ ft} \times 125.5 \text{ lb/ft} \times 2}{21,250 \text{ lb}} = 5.9 \text{ which again implies six pipelayers}$$

If, in this same example, soil conditions required a safe slope of 2.33 then the load overhang would have been 16 ft. At this load overhang the 572R Series 2's rated load capacity is approximately 18,125 lb. Using the equations above, this results in 72.2 ft between lift points which means that seven 572R Series 2 pipelayers are now necessary. Using the second method:

$$\frac{500 \text{ ft} \times 125.5 \text{ lb/ft} \times 2}{18,125 \text{ lb}} = 6.9 \text{ again implying that seven 572R2 pipelayers are needed}$$

Rather than adding another pipelayer, 583T's could be used. At a 16 ft load overhang the 583T has a rated load capacity of 29,400 lb. This translates to 117.1 ft between lift points. If the pipe's bending characteristics will allow this space between lift points, the job could be done with only five 583T's.



# WHEEL TRACTOR-SCRAPERS TOWED SCRAPERS

## CONTENTS

### WHEEL TRACTOR-SCRAPERS

Features .....	8-2
Specifications:	
Standard Scrapers .....	8-3
Tandem Powered and Push-Pull Scrapers ..	8-4
Elevating Scraper .....	8-6
Coal Bowl Wheel Tractor-Scrapers .....	8-7
Ground Engaging Tools:	
Router Bits .....	8-8
Cutting Edges .....	8-8
Bowl Side Protectors .....	8-9
Elevating Scraper .....	8-10
Auger .....	8-10
Material Application Guide .....	8-11
Push-Load TTT Match .....	8-11
Tire Options, All Models .....	8-12
Cushion Hitch .....	8-13
Wheel Tractor-Scraper Anatomy .....	8-13
Use of Rimpull-Speed-Gradeability Curves ..	8-14
Use of Travel Time Charts .....	8-16
Fixed Times for Scrapers .....	8-17
Use of Retarder Curves .....	8-17
Curves/Charts:	
621G Rimpull, Retarding, Travel Times ..	8-19
623G Rimpull, Retarding, Travel Times ..	8-23
627G Rimpull, Retarding, Travel Times ..	8-27
631G Rimpull, Retarding, Travel Times ..	8-31
637G Rimpull, Retarding, Travel Times ..	8-35
657G Rimpull, Retarding, Travel Times ..	8-39

### TOWED SCRAPERS

Features .....	8-43
Applications .....	8-43
Recommended Pull Units .....	8-43
Specifications .....	8-44

**Features:**

- **VHP engines** that deliver 10% more horsepower in gears 3 through 8 in the 620, 630 and 650 G Series.
- **Controlled throttle shifting** improves power train life by reducing fuel injection rate just prior to shifting in the 620, 630 and 650 G Series.
- **HEUI and (EUI) Electronic Unit Injection** electronically maintains fuel settings as well as automatically derate for altitude and air filter restrictions.
- **Hydraulic retarder** protects engine from overspeeding and extends brake life on grades in the 620, 630 and 650 G Series.
- **G Series implement valve** has been relocated to the scraper for improved serviceability on the 620, 630, and 650 G Series.
- **Electro-hydraulic implement controls** replace cab pilot valve and associated lines in the 620, 630, and 650 G Series.
- **Joystick implement control** — bowl, apron, ejector, elevator, transmission hold, cushion hitch, and optional bail are controlled by a joystick in the 620, 630, and 650 G Series.
- **Simplified transmission control** on 620, 630, and 650 G Series. Gear selection choices are 1, 2, and D. Operator can override transmission by manually selecting top gear.

- **G Series rear engines** can be started from the cab. Tachometer can monitor either front or rear engine.
- **G Series Scrapers EMS information** can be viewed in the cab by pressing a tractor/scraper switch. If EMS senses a fault in the scraper, it will automatically switch from tractor to scraper.
- **Eight speed semi-automatic power shift transmissions** used in the 620, 630, and 650 G Series.
- **Differential lock** connects both tractor drive wheels in poor underfoot conditions for positive traction.
- **Cushion Hitch** on 620, 630, and 650 G Series absorbs haul road shocks, prevents loping as well as promotes operator comfort.

**Tandem Powered:**

- **Push-Pull arrangement** allows tandem engine scrapers to assist one another in loading. Recommended for high production applications.

**Elevating:**

- **Infinitely variable elevator speed** on 623G.

Specifications  
● Standard Scrapers

Wheel Tractor-Scrapers



MODEL	621G		631G	
Flywheel Power	246/272 kW	<b>330/365 hp</b>	345/373 kW	<b>462/500 hp</b>
Approx. Operating Weight (Empty)◀	33 995 kg	<b>74,946 lb</b>	47 628 kg	<b>105,002 lb</b>
Scraper Capacity: Struck	12 m <sup>3</sup>	<b>15.7 yd<sup>3</sup></b>	18.3 m <sup>3</sup>	<b>24 yd<sup>3</sup></b>
Heaped	17 m <sup>3</sup>	<b>22 yd<sup>3</sup></b>	26 m <sup>3</sup>	<b>34 yd<sup>3</sup></b>
Rated Load	23 950 kg	<b>52,800 lb</b>	37 013 kg	<b>81,600 lb</b>
Weight Distribution — Empty:				
Drive		<b>67%</b>		<b>64%</b>
Rear		<b>33%</b>		<b>36%</b>
Weight Distribution — Loaded:				
Drive		<b>52%</b>		<b>52%</b>
Rear		<b>48%</b>		<b>48%</b>
Engine Model	<b>C15 ACERT</b>		<b>C18 ACERT</b>	
Rated Engine RPM	<b>1800</b>		<b>1800</b>	
Displacement	15.2 L	<b>928 in<sup>3</sup></b>	18.1 L	<b>1105 in<sup>3</sup></b>
Top Speed (Loaded)	51 km/h	<b>32 mph</b>	53 km/h	<b>33 mph</b>
180° Curb-to-Curb Turning Width	11.7 m	<b>38'5"</b>	12.2 m	<b>40'1"</b>
Tires — Tractor Drive	<b>33.25R29**E3</b>		<b>37.25R35**E3</b>	
Scraper	<b>33.25R29**E3</b>		<b>37.25R35**E3</b>	
Width of Cut	3.02 m	<b>9'11"</b>	3.51 m	<b>11'6"</b>
Maximum Depth of Cut	333 mm	<b>13.1"</b>	437 mm	<b>17.2"</b>
Maximum Depth of Spread	522 mm	<b>20.6"</b>	480 mm	<b>18.9"</b>
Fuel Tank Refill Capacity	606 L	<b>160 U.S. gal</b>	814 L	<b>215 U.S. gal</b>
GENERAL DIMENSIONS:				
Height to Top of Scraper	3.71 m	<b>12'2"</b>	3.86 m	<b>12'8"</b>
Wheelbase	7.72 m	<b>25'4"</b>	8.77 m	<b>28'9"</b>
Overall Length	12.88 m	<b>42'3"</b>	14.71 m	<b>48'3"</b>
Overall Width	3.58 m	<b>11'9"</b>	3.94 m	<b>** 12'11"</b>
Shipping Width (Draft Arm on Inside of Bowl)		—	3.63 m	<b>* 11'11"</b>
Scraper Tread	2.23 m	<b>7'4"</b>	2.46 m	<b>8'1"</b>
Tractor Tread	2.20 m	<b>7'3"</b>	2.46 m	<b>8'1"</b>

\*Optional Shipping Configuration.

\*\*Standard Shipping Configuration.

◀ Operating weight includes standard machine, coolant, lubricants, full fuel tank, and operator.

**Single Engine Open Bowl**

The Open Bowl Wheel Tractor-Scraper is available as a self-loading or push-loaded hauling system with a broad material appetite. The broad material appetite allows the Open Bowl Wheel Tractor-Scraper to be used in general construction, heavy construction, mining, and waste applications.

**Open Bowl Advantages:**

- Quick load/unload
- Spread evenly on-the-go
- Broad material appetite
- Aids in compaction
- Varying material conditions
- High production

**Single Engine Advantages**

**(Compared to Tandem Engine):**

- Low fuel usage
- Lower gross vehicle weight
- Loads quickly with the aid of a Track-Type Tractor and hauls to fill carrying minimum machine weight



# Wheel Tractor-Scrapers

## Specifications

- Tandem Powered
- Push-Pull



MODEL	627G		637G		657G	
Flywheel Power: Tractor	246/272 kW	<b>330/365 hp</b>	345/373 kW	<b>462/500 hp</b>	421/447 kW	<b>564/600 hp</b>
Scraper	178/198 kW	<b>239/266 hp</b>	198/211 kW	<b>266/283 hp</b>	306/337 kW	<b>410/451 hp</b>
Approx. Operating Weight (Empty)◀	37 922 kg	<b>83,604 lb</b>	51 963 kg	<b>114,559 lb</b>	68 384 kg	<b>150,760 lb</b>
Scraper Capacity: Struck	12 m <sup>3</sup>	<b>15.7 yd<sup>3</sup></b>	18.3 m <sup>3</sup>	<b>24 yd<sup>3</sup></b>	24.5 m <sup>3</sup>	<b>32 yd<sup>3</sup></b>
Heaped	17 m <sup>3</sup>	<b>22 yd<sup>3</sup></b>	26 m <sup>3</sup>	<b>34 yd<sup>3</sup></b>	33.6 m <sup>3</sup>	<b>44 yd<sup>3</sup></b>
Rated Load	23 950 kg	<b>52,800 lb</b>	37 013 kg	<b>81,600 lb</b>	47 174 kg	<b>104,000 lb</b>
Weight Distribution — Empty: Front		<b>59%</b>		<b>59%</b>		<b>58%</b>
Rear		<b>41%</b>		<b>41%</b>		<b>42%</b>
Weight Distribution — Loaded: Front		<b>50%</b>		<b>50%</b>		<b>50%</b>
Rear		<b>50%</b>		<b>50%</b>		<b>50%</b>
Engine Model: Tractor	<b>C15 ACERT</b>		<b>C18 ACERT</b>		<b>C18 ACERT</b>	
Scraper	<b>C9 ACERT</b>		<b>C9 ACERT</b>		<b>C15 ACERT</b>	
Rated Engine RPM: Tractor	<b>1800</b>		<b>1800</b>		<b>1800</b>	
Scraper	<b>2000</b>		<b>2000</b>		<b>1800</b>	
Displacement: Tractor	15.2 L	<b>928 in<sup>3</sup></b>	18.1 L	<b>1105 in<sup>3</sup></b>	18.1 L	<b>1105 in<sup>3</sup></b>
Scraper	8.8 L	<b>538 in<sup>3</sup></b>	8.8 L	<b>538 in<sup>3</sup></b>	15.2 L	<b>928 in<sup>3</sup></b>
Top Speed (Loaded)	51 km/h	<b>32 mph</b>	53 km/h	<b>33 mph</b>	53 km/h	<b>33 mph</b>
180° Curb-to-Curb Turning Width	11.7 m	<b>38'5"</b>	12.2 m	<b>40'1"</b>	14.2 m	<b>46'7"</b>
Tires — Tractor Drive	<b>33.25R29**E3</b>		<b>37.25R35**E3</b>		<b>40.5/75R39**E3</b>	
Scraper	<b>33.25R29**E3</b>		<b>37.25R35**E3</b>		<b>40.5/75R39**E3</b>	
Width of Cut	3.02 m	<b>9'11"</b>	3.51 m	<b>11'6"</b>	3.85 m	<b>12'8"</b>
Maximum Depth of Cut	333 mm	<b>13.1"</b>	437 mm	<b>17"</b>	440 mm	<b>17.3"</b>
Maximum Depth of Spread	522 mm	<b>20.6"</b>	480 mm	<b>18.9"</b>	660 mm	<b>26"</b>
Fuel Tank Refill Capacity: Tractor	—		—		—	
Scraper	1105 L	<b>292 U.S. gal</b>	1268 L	<b>335 U.S. gal</b>	1597 L	<b>424 U.S. gal</b>
<b>GENERAL DIMENSIONS:</b>						
Height to Top of Scraper	3.81 m	<b>12'6"</b>	4.18 m	<b>13'9"</b>	4.62 m	<b>15'2"</b>
Wheelbase	7.72 m	<b>25'4"</b>	8.77 m	<b>28'9"</b>	9.96 m	<b>32'8"</b>
Overall Length	12.88 m	<b>42'3"</b>	14.71 m	<b>48'3"</b>	16.2 m	<b>53'1"</b>
Overall Width	3.58 m	<b>11'9"</b>	3.94 m	<b>** 12'11"</b>	4.35 m	<b>14'4"</b>
Shipping Width (Draft Arm on Inside of Bowl)	—		3.63 m	<b>* 11'11"</b>	3.91 m	<b>** 12'10"</b>
Scraper Tread	2.23 m	<b>7'4"</b>	2.46 m	<b>8'1"</b>	2.81 m	<b>9'3"</b>
Tractor Tread	2.20 m	<b>7'3"</b>	2.46 m	<b>8'1"</b>	2.63 m	<b>8'8"</b>
<b>PUSH-PULL GENERAL DIMENSIONS:</b>						
Operating Weight (Empty)◀	39 443 kg	<b>86,957 lb</b>	54 057 kg	<b>119,175 lb</b>	72 804 kg	<b>160,505 lb</b>
Overall Length	15.2 m	<b>49'7"</b>	16.64 m	<b>54'7"</b>	18.01 m	<b>59'1"</b>
Weight Distribution — Empty: Front		<b>59%</b>		<b>60%</b>		<b>58%</b>
Rear		<b>41%</b>		<b>40%</b>		<b>42%</b>
Weight Distribution — Loaded: Front		<b>51%</b>		<b>51%</b>		<b>51%</b>
Rear		<b>49%</b>		<b>49%</b>		<b>49%</b>

\*Optional Shipping Configuration.

\*\*Standard Shipping Configuration.

◀ Operating weight includes standard machine, coolant, lubricants, full fuel tank, and operator.

- Specifications
- Tandem Powered
    - Push-Pull

## Wheel Tractor-Scrapers

### Tandem Engine Open Bowl

The Open Bowl Wheel Tractor-Scraper is available as a self-loading, push-loaded, or push-pulled hauling system with a broad material appetite. The broad material appetite allows the Open Bowl Wheel Tractor-Scraper to be used in general construction, heavy construction, mining, and waste applications.

#### Open Bowl Advantages:

- Quick load/unload
- Spread evenly on-the-go
- Broad material appetite
- Aids in compaction
- High Production
- Varying material conditions
- High production

#### Tandem Engine Advantages

##### (Compared to Single Engine):

- More power for loading, traveling up grades, or over fill area
- Faster cycle times
- High rolling resistance applications
- Variable site conditions
- Poor underfoot conditions
- Steep grades
- Can be self-loaded, push loaded with the aid of a Track-Type Tractor, or push-pulled



MODEL	623G	
Flywheel Power	246/272 kW	330/365 hp
Approx. Operating Weight (Empty)◀	37 510 kg	82,695 lb
Scraper Capacity: Struck	13.8 m <sup>3</sup>	18 yd <sup>3</sup>
Heaped	17.6 m <sup>3</sup>	23 yd <sup>3</sup>
Rated Load	25 038 kg	55,200 lb
Weight Distribution — Empty:		
Drive	63%	
Rear	37%	
Weight Distribution — Loaded:		
Drive	52%	
Rear	48%	
Engine Model	<b>C15 ACERT</b>	
Rated Engine RPM	<b>1800</b>	
Displacement	15.2 L	928 in <sup>3</sup>
Top Speed (Loaded)	51 km/h	32 mph
180° Curb-to-Curb Turning Width	12.0 m	39'4"
Tires — Standard:		
Tractor	<b>33.25R29**E3</b>	
Scraper	<b>33.25R29**E3</b>	
Width of Cut	3.5 m	11'6"
Maximum Depth of Cut	330 mm	13"
Elevator Flight Spacing	520 mm	20"
Number of Flights	15	
Maximum Floor Opening	1.53 m	5'0"
Maximum Depth of Spread	380 mm	15"
Fuel Tank Refill Capacity	606 L	160 U.S. gal
<b>GENERAL DIMENSIONS:</b>		
Height to Top of Scraper	3.71 m	12'2"
Wheelbase	7.98 m	26'2"
Overall Length	13.17 m	43'2"
Overall Width	3.58 m	11'9"
Scraper Tread	2.23 m	7'4"
Tractor Tread	2.20 m	7'3"

◀Operating weight includes coolants, lubricants, full fuel tank and operator.

### Elevating

The Elevating Wheel Tractor-Scraper is a self-loading hauling system with the added ability to mix/homogenize material and do precise finishing work.

#### Elevating Bowl Advantages:

- Load/haul/spread with little support equipment
- Conditions material as it loads
- Capable to work as a single machine
- Aids in compaction
- Finishing work
- Low rolling resistance applications
- Short cut areas
- Favorable material types
- Windrow applications
- Thin, precise lifts

#### Single Engine Advantages

##### (Compared to Tandem Engine):

- Low fuel usage
- Lower gross vehicle weight

Specifications  
 ● Coal Bowl Wheel Tractor-Scrapers

Wheel Tractor-Scrapers



MODEL	637G		657G	
Flywheel Power: Tractor	345/373 kW	<b>462/500 hp</b>	421/447 kW	<b>564/600 hp</b>
Scraper	198/211 kW	<b>266/283 hp</b>	306/337 kW	<b>410/451 hp</b>
Approx. Operating Weight (Empty)	54 050 kg	<b>118,909 lb</b>	72 190 kg	<b>158,817 lb</b>
Scraper Capacity: Struck	31 m <sup>3</sup>	<b>41 yd<sup>3</sup></b>	45 m <sup>3</sup>	<b>59 yd<sup>3</sup></b>
Heaped	38 m <sup>3</sup>	<b>50 yd<sup>3</sup></b>	56 m <sup>3</sup>	<b>73 yd<sup>3</sup></b>
Rated Load	34 473 kg	<b>76,000 lb</b>	49 895 kg	<b>110,000 lb</b>
Approx. Operating Weight (Loaded)	88 409 kg	<b>194,909 lb</b>	121 933 kg	<b>268,817 lb</b>
Top Speed (Loaded)	53 km/h	<b>33 mph</b>	53 km/h	<b>33 mph</b>
180° Curb-to-Curb Turning Width	13.7 m	<b>44'10"</b>	15.6 m	<b>51'3"</b>
<b>GENERAL DIMENSIONS:</b>				
Height to Top of Scraper	4.18 m	<b>13'9"</b>	4.62 m	<b>15'2"</b>
Wheelbase	9.53 m	<b>31'3"</b>	11.01 m	<b>36'1"</b>
Overall Length	15.47 m	<b>50'9"</b>	17.21 m	<b>56'5"</b>
Overall Width	3.94 m	** <b>12'11"</b>	4.35 m	<b>14'4"</b>
Shipping Width (Draft Arm on Inside of Bowl)	3.63 m	* <b>11'11"</b>	3.91 m	** <b>12'10"</b>
Scraper Tread	2.46 m	<b>8'1"</b>	2.81 m	<b>9'3"</b>
Tractor Tread	2.46 m	<b>8'1"</b>	2.63 m	<b>8'8"</b>

\*Optional Shipping Configuration.  
 \*\*Standard Shipping Configuration.

**Coal Bowl**

Coal Bowl Wheel Tractor-Scrapers are typically used for building and maintaining coal stockpiles and hauling coal to the supply system at coal power plants. The self-loading capability, large capacity, coal pile compaction, and high speed of Coal Bowl Wheel Tractor-Scrapers make them the tool of choice for moving coal both short and long distances. Coal Bowl Wheel Tractor-Scrapers are available in the 637G and 657G tandem engine models.

**Coal Bowl Advantages:**

- Load hoppers
- Manage coal stockpiles
- Compaction reduces risk of spontaneous combustion in coal stockpile
- Exclusively designed large capacity coal bowls

**Notes:**

- The 637G Coal Scraper is 736 mm (**29.0"**) longer, the bowl sides are 476 mm (**18.7"**) taller, and the apron is 499 mm (**19.6"**) taller than its earthmoving counterpart.
- The 657G Coal Scraper is 1072 mm (**42.2"**) longer, the bowl sides are 1010 mm (**39.8"**) taller, the apron is 677 mm (**26.7"**) taller, and the ejector is 944 mm (**37.2"**) taller than its earthmoving counterpart.

- Router Bits
- Cutting Edges

### WHEEL TRACTOR-SCRAPER GROUND ENGAGING TOOLS

#### ROUTER BITS

Cat router bits help prevent wear and costly damage to the scraper bowl. All router bits are forged DH-2 steel and through-hardened to prevent breakage and prolong life.



#### Standard Router Bit

- Available for all models.



#### Heavy Duty Router Bit

- 45% more wear material than the standard router bits.



#### ARM Router Bit

- Available for virtually all models in high abrasion, low impact applications.



#### Level Router Bit

- Used for clean-up work and keeps material in front of the cutting edges.

#### CUTTING EDGES

Cat cutting edges are rolled from DH-2 steel and through-hardened for strength and wear resistance and are available in standard, abrasion resistant material (ARM), and serrated versions.



#### Standard center and end-cutting edges

- For use on all scraper models (open bowl, auger and elevating scraper).
- Used in low-to-medium abrasion and low-to-high impact conditions.
- Available in various thicknesses and sizes for both stinger and level-cut arrangements.
- Can be reversed or propellered for prolonged edge use and improved cost per hour.



#### ARM center and end cutting edges

- For use on all scraper models (open bowl, auger and elevating scraper).
- Used in medium-to-high abrasion and low-to-high impact conditions.
- Available in various thicknesses and sizes for both stinger and level-cut arrangements.
- Can be reversed or propellered for prolonged edge use and improved cost per hour.

- Cutting Edges
- Bowl Side Protectors



**ARM serrated center cutting edge**

- For use on 620, 630 and 650 Series Scraper (open bowl, auger and elevating scraper).
- Used in medium-to-high abrasion and medium-to-high impact conditions where increased penetration and aggressive digging action is required.
- Available in various thicknesses and sizes for both stinger and level-cut arrangements.
- Edges can be reversed or propellered around for prolonged edge use and improved cost per hour.



**Integrated tooth center cutting edge**

- For use on 623 and 633 Elevating Scraper, and 620 Series Auger Scraper.
- Used in low-to-high abrasion conditions for improved penetration in medium-to-high impact conditions.
- Include cast-in-place adapters, which accept pin-on tips.



**Bolt-on adapters**

- For use on Elevating Scraper 613, 615, 623 and 633.
- Used in low-to-high abrasion conditions and low-to-medium impact conditions when improved penetration is needed.
- Bolt-on adapters accept pin-on tips.



**Special serrated cutting edges**

- For site-specific applications and conditions.
- Use on 620, 630 and 650 Series Scraper (open bowl, auger and elevating scraper).
- Custom-designed edges have sharp teeth for low-to-medium abrasion and low-to-medium impact conditions.

**BOWL SIDE PROTECTORS**

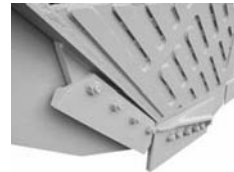

- Bowl Side protectors are available in two styles: Bolt on bowl side protectors and pin on bowl side protectors.
- Bolt on style takes a weld on adapter plate that accepts the bolt on bowl side protector. This is available for 620, 630 and 650 Series scrapers.
- Pin on style takes a weld on adapter plate that accepts the pin on bowl side protector. This is available for 620, 630 and 650 Series scrapers.

## Wheel Tractor-Scrapers

### Ground Engaging Tools

- Elevating Scraper
- Auger

### ELEVATING SCRAPER



- Flight assemblies.
- Chain assemblies.\*
- Sprockets.\*
- Idlers and idler groups.
- Rollers and roller groups.

\*Optional heavy-duty chain and sprocket for 623G available through your Cat dealer.

In today's competitive environment, machines must operate efficiently. Inspections identify problems that cause machines to burn more fuel and shorten component life.

### AUGER



#### Plastic liners

- For use in low-to-high abrasion, plastic liners prevent sticky material from building up on the auger.

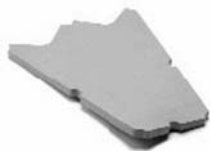

#### Steel wear plates

- For use in medium-to-high abrasion and medium-to-high impact conditions to protect the auger surface.



#### Standard auger shoe

- For use in low-to-medium abrasion and low-to-high impact conditions where accelerated wear is not a problem.



#### Tungsten carbide auger shoe

- For use in medium-to-high abrasion and medium-to-high impact conditions where accelerated wear is a problem.



#### Auger cutting edge

- For use in low-to-high abrasion and low-to-high impact conditions.

Ground Engaging Tools  
 ● Material Application Guide  
 ● Push-Load TTT Match

Wheel Tractor-Scrapers

Material Application Guide	Elevator	Self-Load Single and Tandem Engine	Push-Load Single and Tandem Engine	Push Pull	Auger Tandem Engine	Coal Bowl	Remarks
Decomposed Granite/Soil							Excellent loading
Decomposed Granite (Ripped)							Excellent loading by push-loading or push-pull to reduce cutting of tires
Moist Top Soil							Good to Excellent Loading
Top Soil							Excellent for WTS
Clay/Sand Mixture							Excellent for WTS
Sand							Good to Excellent loading, but some cases may need to be push loaded by a TTT or Push-Pull
Antigo							Excellent WTS material: lower portion may require ripping depending on material density
Coal							Excellent for WTS: ripping may be required in dense material
Limestone							In natural state, not suitable for WTS
Granite							Not suitable for WTS
Sandstone							For WTS to be productive in sandstone, material needs to be ripped. In some cases where density is high, WTS would not be a good fit
Shot Rock							Below 610 mm (24") good for WTS when push-loaded by a TTT to reduce cutting of tires
Loess Overtill (Banked)							Excellent for WTS: ripping may be required in dense material
Loess Overtill (Ripped)							Excellent WTS material provided rock size does not exceed 610 mm (24")
Aridisols							Excellent WTS material, ripping will decrease load times
Glacial Outwash/ River Rock							Excellent WTS material provided rock size does not exceed 610 mm (24")

FOR MORE INFORMATION ON WHEEL TRACTOR-SCRAPER MATERIAL APPLICATIONS REFERENCE PUBLICATION AEXQ0442.

Push-Load TTT Match	D8	D9	D10	D11
621				
627				
631				
637				
657				



MODEL TIRE SIZE	PLY RATING/ STAR RATING*	TYPE
<b>621G</b>		
<b>623G</b>		
33.25R29◀	★★	E-3
33.25-29	32	E-3
<b>627G</b>		
33.25R29◀	★★	E-3

MODEL TIRE SIZE	PLY RATING/ STAR RATING*	TYPE
<b>631G</b>		
<b>637G</b>		
37.25R35◀	★★	E-3
<b>657G</b>		
40.5/75R39◀	★★	E-3

\*Manufacturer uses star (★) rating system instead of ply rating.  
 ◀Recommended tire.

### CUSHION HITCH

- Cushion Hitch dampens shocks to provide a smoother ride
- Nitrogen over oil accumulators absorb and dampen road shock

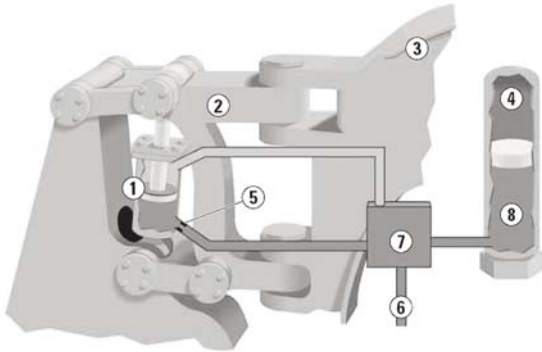

1. Load Cylinder
2. Hitch Castings
3. Scraper Gooseneck
4. Nitrogen Accumulators
5. Orifice
6. Oil from Tractor Hydraulic System
7. Leveling Valve
8. Free-Floating Pistons

### WHEEL TRACTOR-SCRAPER ANATOMY

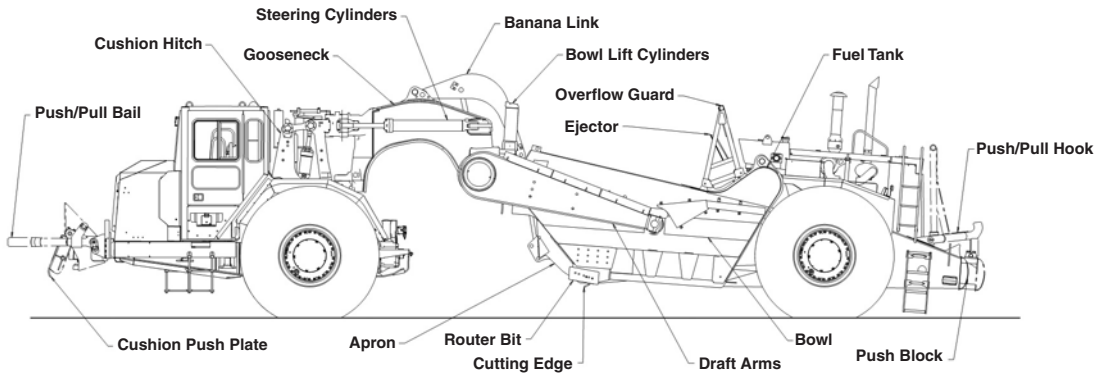

**USE OF RIMPULL-SPEED-GRADEABILITY CURVES**

*The following explanation applies to Rimpull-Speed-Gradeability curves for Wheel Tractor-Scrapers, Construction & Mining Trucks/Tractors and Articulated Trucks.*

Maximum speed attainable, gear range and available rimpull can be determined from curves on the following pages when machine weight and total effective grade (or total resistance) are known.

**Rimpull** is the force (in kg, lb or kN) available between the tire and the ground to propel the machine (limited by traction).

**Weight** is defined as Gross Machine Weight (kg or lb) = Machine + Payload.

**Total Effective Grade (or Total Resistance)** is grade resistance plus rolling resistance expressed as percent grade.

Grade is measured or estimated.

Rolling resistance is estimated (see Tables section for typical values.)

10 kg/metric ton (20 lb/U.S. ton) = 1% adverse grade.

Example

With a 6% grade and a rolling resistance of 40 kg/metric ton (80 lb/U.S. ton), find total resistance.

Rolling resistance = 40 kg/t ÷ 10 = 4% Effective Grade

(English: 80 lb ÷ 20 = 4%)

Total resistance = 4% rolling + 6% grade = 10%

**Altitude Derating**

Rimpull force and speed must be derated for altitude similar to flywheel horsepower. The percentage loss in rimpull force approximately corresponds to the percentage loss in flywheel horsepower. See Tables Section for altitude derations.

**Rimpull-Speed-Gradeability**

To determine gradeability performance: Read from gross weight down to the % of total resistance. (Total resistance equals actual % grade *plus* 1% for each 10 kg/metric ton (20 lb./U.S. ton) of rolling resistance.) From this weight-resistance point, read horizontally to the curve with the highest obtainable speed range, then down to the maximum speed. Usable rimpull depends upon traction and weight on drive wheels.

Example problem:

A 631G with an estimated payload of 37 013 kg (81,600 lb) is operating on a total effective grade of 10%. Find the available rimpull and maximum attainable speed.

Empty weight payload = Gross Weight  
 47 628 kg + 37 013 kg = 84 641 kg  
 (105,002 lb + 81,600 lb = 186,602 lb)

*Solution:* Using graph on the next page, read from 84 641 kg (186,602 lb) (point A) on top of gross weight scale down the line to the intersection of the 10% total resistance line (point B).

Go across horizontally from B to the Rimpull Scale on the left (point D). This gives the required rimpull: 7756 kg (17,100 lb).

Where the line cuts the speed curve (point C), read down vertically (point E) to obtain the maximum speed attainable for the 10% effective grade: 12.9 km/h (8 mph).

**ANSWER:** The machine will climb the 10% effective grade at a maximum speed of 12.9 km/h (8 mph) in 4th gear. Available rimpull is 7756 kg (17,100 lb).



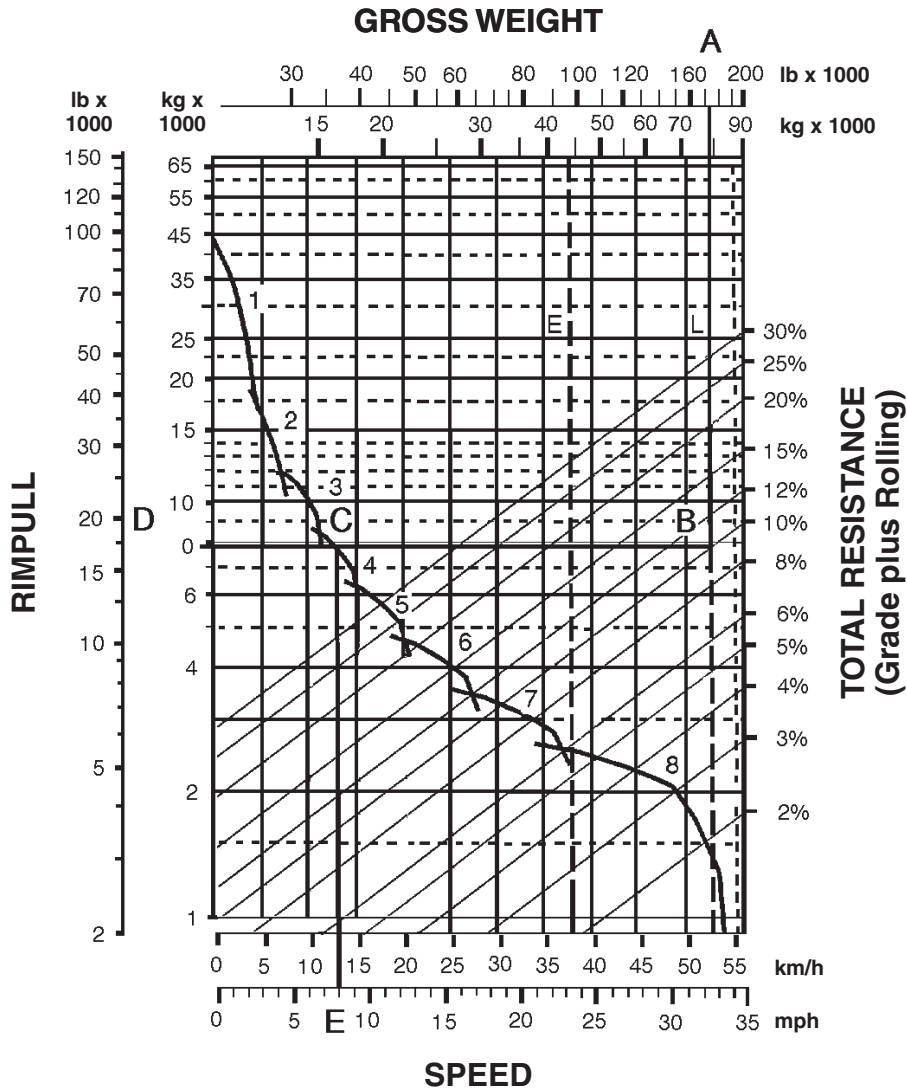

**KEY**

- 1 — 1st Gear Torque Converter Drive
- 2 — 2nd Gear Torque Converter Drive
- 3 — 3rd Gear Direct Drive
- 4 — 4th Gear Direct Drive
- 5 — 5th Gear Direct Drive
- 6 — 6th Gear Direct Drive
- 7 — 7th Gear Direct Drive
- 8 — 8th Gear Direct Drive

**KEY**

- A — Loaded 84 641 kg (186,602 lb)
- B — Intersection with 10% total resistance line
- C — Intersection with rimpull curve (4th gear)
- D — Required rimpull 7756 kg (17,100 lb)
- E — Speed 12.9 km/h (8 mph)

**USE OF TRAVEL TIME CHARTS**

The following explanation applies to travel time charts for Wheel Tractor-Scrapers, Construction & Mining Trucks and Articulated Trucks.

One-way travel time can be determined from graphs on the following pages when one-way travel distance and total resistance (expressed in percent) are known. 10 kg/metric ton (20 lb/U.S. ton) equals 1% equivalent grade.

If total resistance is negative (grade assistance greater than rolling resistance) machine may accelerate downhill requiring the use of retarder or brakes. Travel time charts cannot be used in these cases. Consult respective machine retarder curve to establish maximum safe downhill speed.

Two graphs are given for each hauling unit: one for the machine carrying its rated payload and one for the empty machine.

Travel times were derived using Cat Machine Simulation Program and standard tire inputs. Travel times for machines equipped with (larger) optional tires vary slightly.

Example problem:

631G hauls its rated payload 37 013 kg — 26 bank cubic meters (81,600 lb — 34 bank cubic yards) on a 4% road for 610 m (2000 feet) and returns on a 0% road for 760 m (2500 feet). Find the cycle time.

*Haul —*

Using the graph for the Loaded machine, read from the Travel Distance (one way) scale at 610 m (2000 feet) across to the 4% total resistance line (point A). From (point A) read down to the Travel Time (one way) scale to determine haul time = 1.4 minutes.

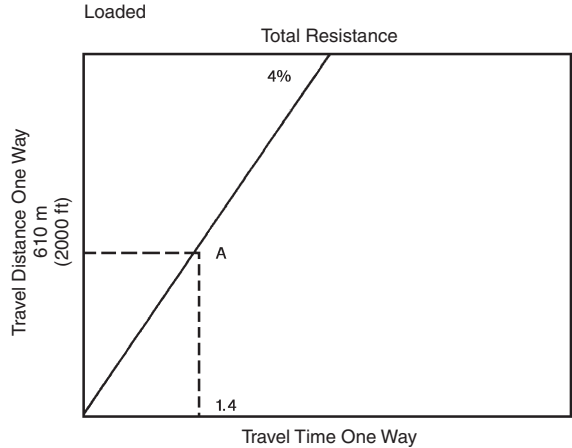

*Return —*

Using the graph for the Empty machine, read from the Travel Distance (one way) scale at 760 m (2500 feet) across to the 0% total resistance line (point A). From (point A) read down to the Travel Time (one way) scale to determine return time = 1 min.

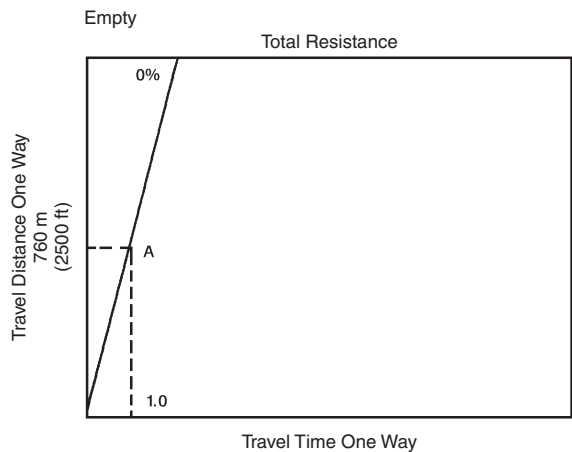

*Cycle Time* —

$$\begin{aligned}
 &= \text{load}^* + \text{haul} + \text{maneuver \& spread}^* + \text{return} \\
 &= 0.6 + 1.4 + 0.7 + 1.0 \\
 &= 3.7 \text{ min.}
 \end{aligned}$$

\*For fixed time (load, maneuver and spread) see the table below.

When cycle time and payload are known, productivity can be calculated. For a more complex example see the Earthmoving Section.



**TYPICAL FIXED TIMES FOR SCRAPERS**

(Times may vary depending on job conditions)

Model	Loaded By	Load Time (Min.)	Maneuver and Spread or Maneuver and Dump (Min.)
613G	Self	0.9	0.7
623G	Self	0.9	0.7
621G	One D8R	0.5	0.7
627G	One D8R	0.5	0.6
621G	One D9R	0.4	0.7
627G	One D9R	0.4	0.6
627G/PP	Self	0.9*	0.6
631G	One D9R	0.6	0.7
637G	One D9R	0.6	0.6
631G	One D10R	0.5	0.7
637G	One D10R	0.5	0.6
637G/PP	Self	1.0*	0.6
657G	One D11R	0.6	0.6
657G	Push Pull	1.1*	0.6
	Self		
627G	Auger	0.7	0.7
637G	Auger	0.8	0.7
637G	Coal	0.8	0.7
657G	Auger	1.0	0.6
657G	Coal	0.8	0.6

\*Load time per pair, including transfer time.

**NOTE:** Empty Weights shown on the Wheel Tractor-Scraper charts includes ROPS Canopy. The travel times will remain within acceptable limits when applied to a non-ROPS equipped machine. When calculating TMPH loadings any additional weight must be considered in establishing mean tire loads.

**USE OF RETARDER CURVES**

The following explanation applies to retarder curves for Wheel Tractor-Scrapers and Articulated Trucks.

The speed that can be maintained (without use of service brake) when the machine is descending a grade with retarder fully on can be determined from the retarder curves in this section if gross machine weight and total effective grade are known.

**Total Effective Grade (or Total Resistance)** is grade assistance *minus* rolling resistance.

10 kg/metric ton (20 lb/U.S. ton) = 1% adverse grade.

Example

15% favorable grade with 5% rolling resistance. Find Total Effective Grade.

$$\text{Total Effective Grade} = 15\% \text{ Grade Assistance} - 5\%$$

$$\text{Rolling Resistance} = 10\% \text{ Total Effective Grade Assistance.}$$

Example problem:

A 651E with an estimated payload of 47 175 kg (104,000 lb) descends a 10% total effective grade. Find constant speed and gear range with maximum retarder effort. Find travel time if the slope is 610 m (2000 ft) long.

$$\begin{aligned}
 \text{Empty Weight} + \text{Payload} &= \text{Gross Weight} \\
 &= 60\,950 \text{ kg} + 47\,175 \text{ kg} = 108\,125 \text{ kg} \\
 &= (134,370 \text{ lb} + 104,000 \text{ lb} = 238,370 \text{ lb})
 \end{aligned}$$

*Solution:* Using the retarder curve below, read from 108 125 kg (238,370 lb) (point A) on top of gross weight scale down the line to the intersection of the 10% effective grade line (point B).

Go across horizontally from point B to the intersection of the retarder curve (point C). Point C intersects at the 5 (5th gear) range.

Where point C intersects the retarder curve, read down vertically to point D on the bottom scale to obtain the constant speed: 21.7 km/h (13.5 mph).

ANSWER: The 651E will descend the slope at 21.7 km/h (13.5 mph) in 5th gear. Travel time is 1.68 minutes.

$$\frac{610 \text{ m}}{363 \text{ m/min}} = 1.68 \text{ min}$$

\*(mph × 88 = F.P.M.)

$$\frac{2000 \text{ ft}}{13.5 \text{ mph} \times 88^*} = 1.68 \text{ min}$$

**NOTE:** The basic Distance-Speed-Time formula is  $60 D \div S = T$  (or “60 D Street”), where 60 is minutes, D is distance, S is speed and T is time. In the above problem,  $60 \times 610 \text{ m} \div 21.7 \text{ km/h} \times 1000 = T$ .

$$\frac{60 \times 610}{21.7 \times 1000} = T = (1.68)$$

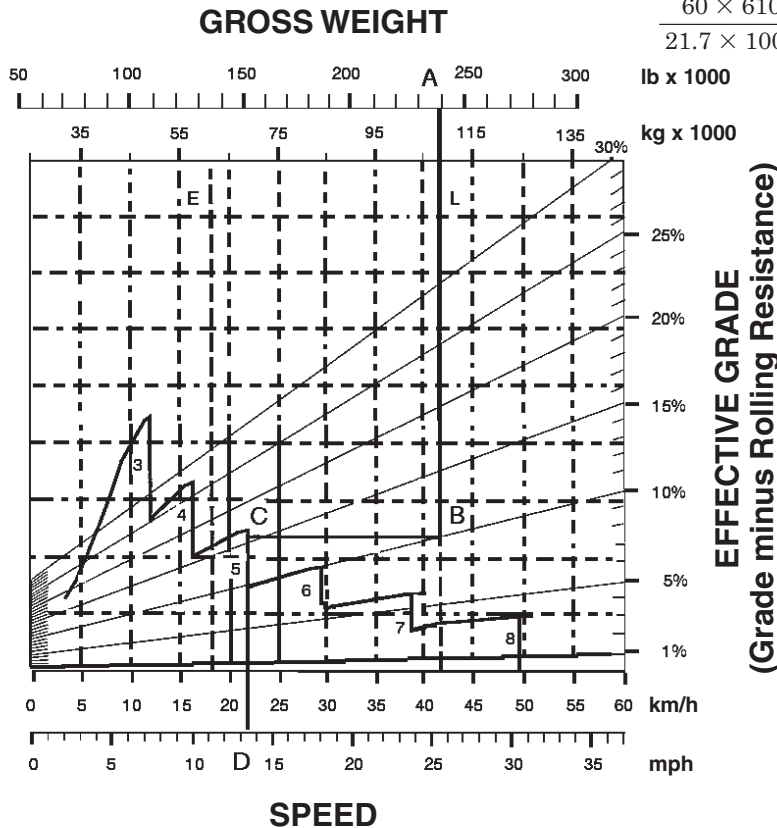

KEY

- 3 — 3rd Gear Direct Drive
- 4 — 4th Gear Direct Drive
- 5 — 5th Gear Direct Drive
- 6 — 6th Gear Direct Drive
- 7 — 7th Gear Direct Drive
- 8 — 8th Gear Direct Drive

KEY

- A — Loaded 108 125 kg (238,370 lb)
- B — Intersection with 10% effective grade line
- C — Intersection with retarder curve (5th gear)
- D — Constant speed 21.7 km/h (13.5 mph)

**TIER 3  
 STANDARD ARRANGEMENT\*  
 GROSS WEIGHT**

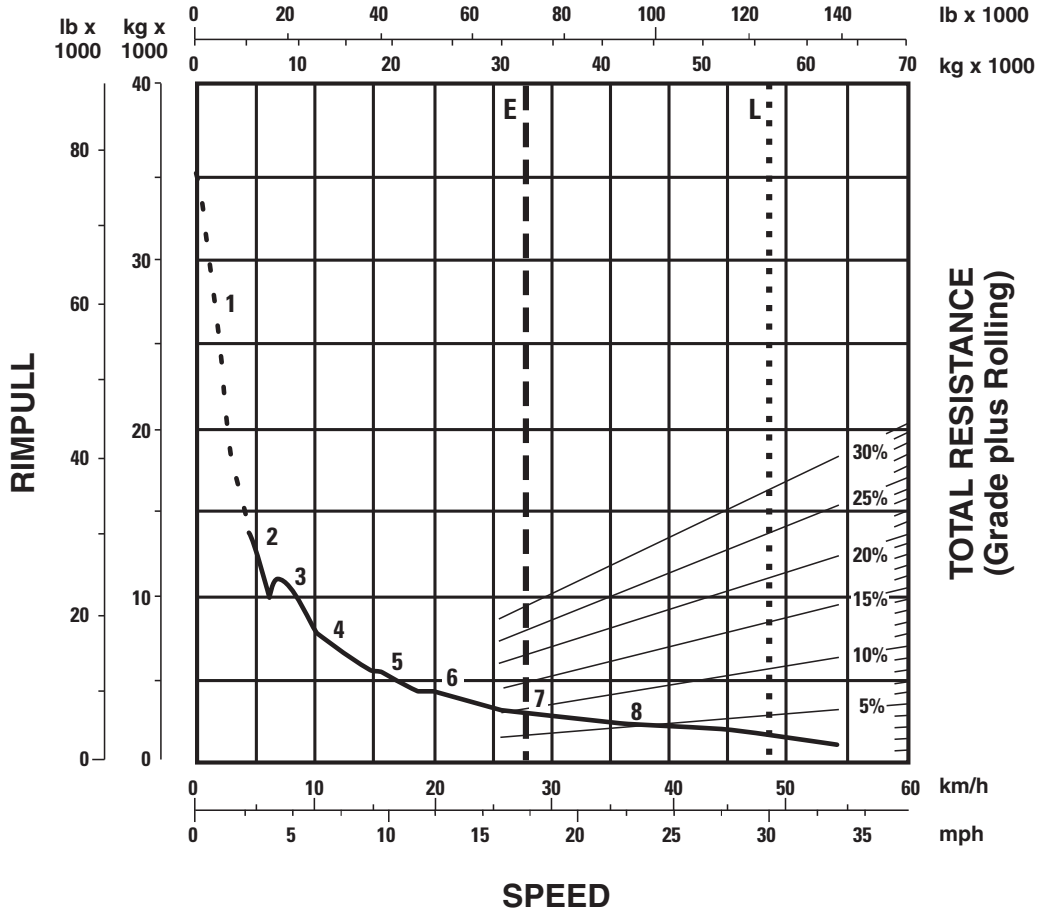

\*at sea level

**KEY**

- 1 — 1st Gear Torque Converter Drive
- 2 — 2nd Gear Torque Converter Drive
- 3 — 3rd Gear Direct Drive
- 4 — 4th Gear Direct Drive
- 5 — 5th Gear Direct Drive
- 6 — 6th Gear Direct Drive
- 7 — 7th Gear Direct Drive
- 8 — 8th Gear Direct Drive

**KEY**

- E — Empty 33 995 kg (74,946 lb)
- L — Loaded 57 945 kg (127,746 lb)



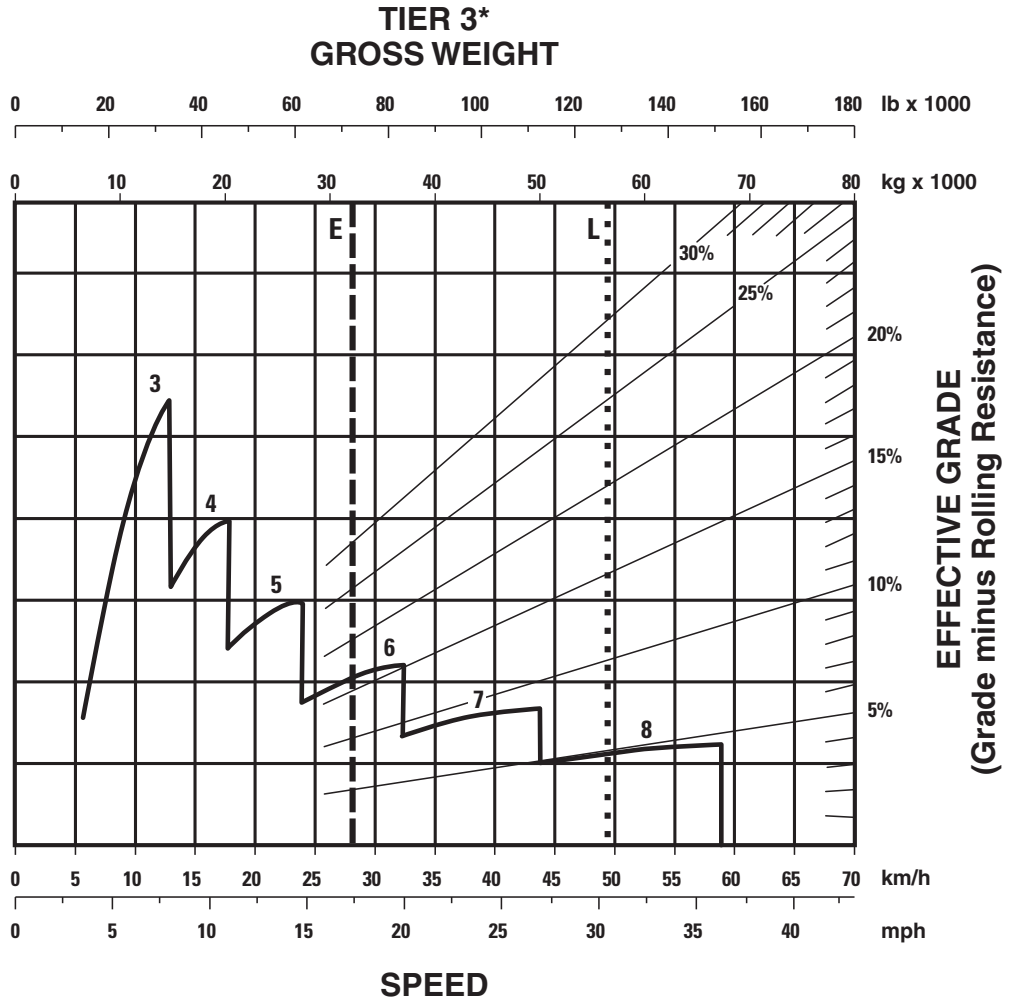

\*at sea level

**KEY**

- 3 — 3rd Gear Direct Drive
- 4 — 4th Gear Direct Drive
- 5 — 5th Gear Direct Drive
- 6 — 6th Gear Direct Drive
- 7 — 7th Gear Direct Drive
- 8 — 8th Gear Direct Drive

**KEY**

- E — Empty 33 995 kg (74,946 lb)
- L — Loaded 57 945 kg (127,746 lb)

**LOADED**

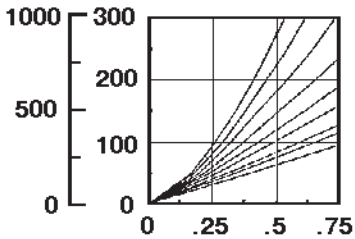
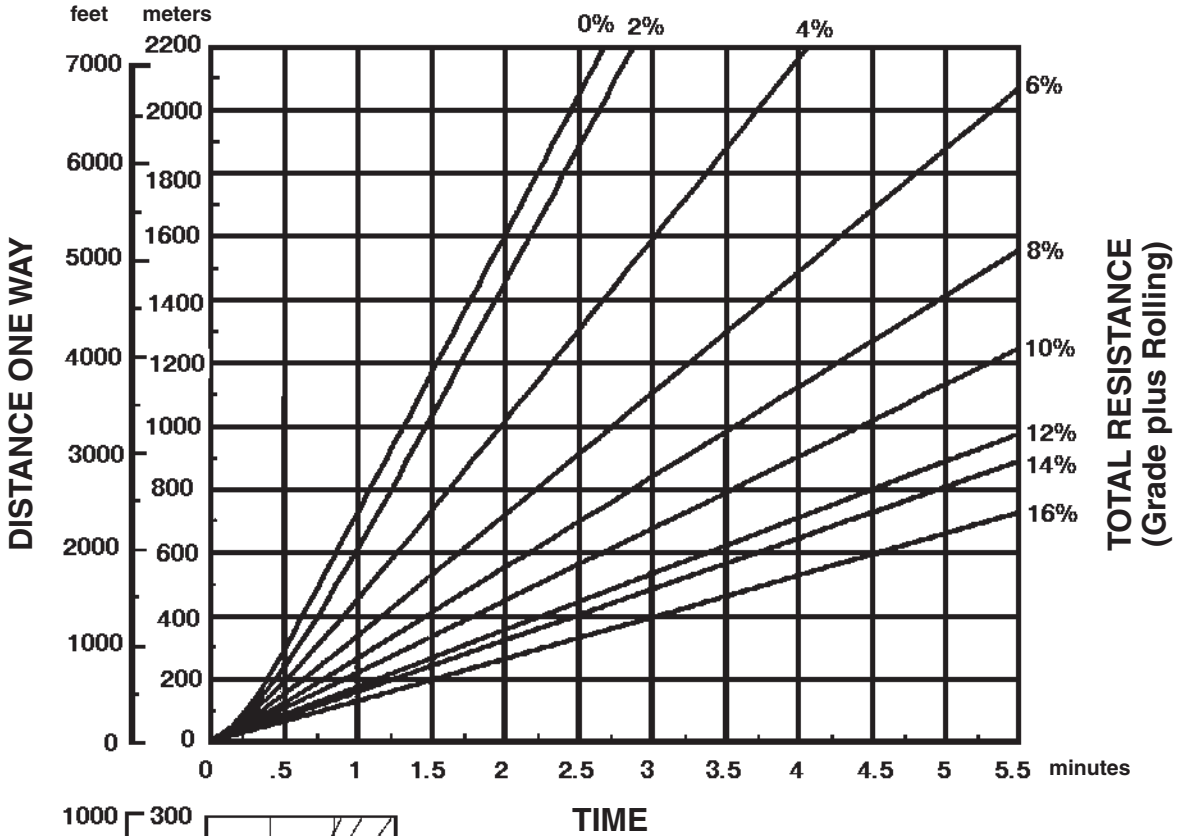

Empty weight: 33 995 kg (74,946 lb)  
 Payload: 23 950 kg (52,800 lb)

**EMPTY**

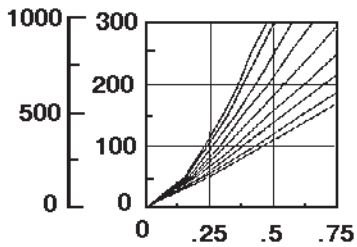
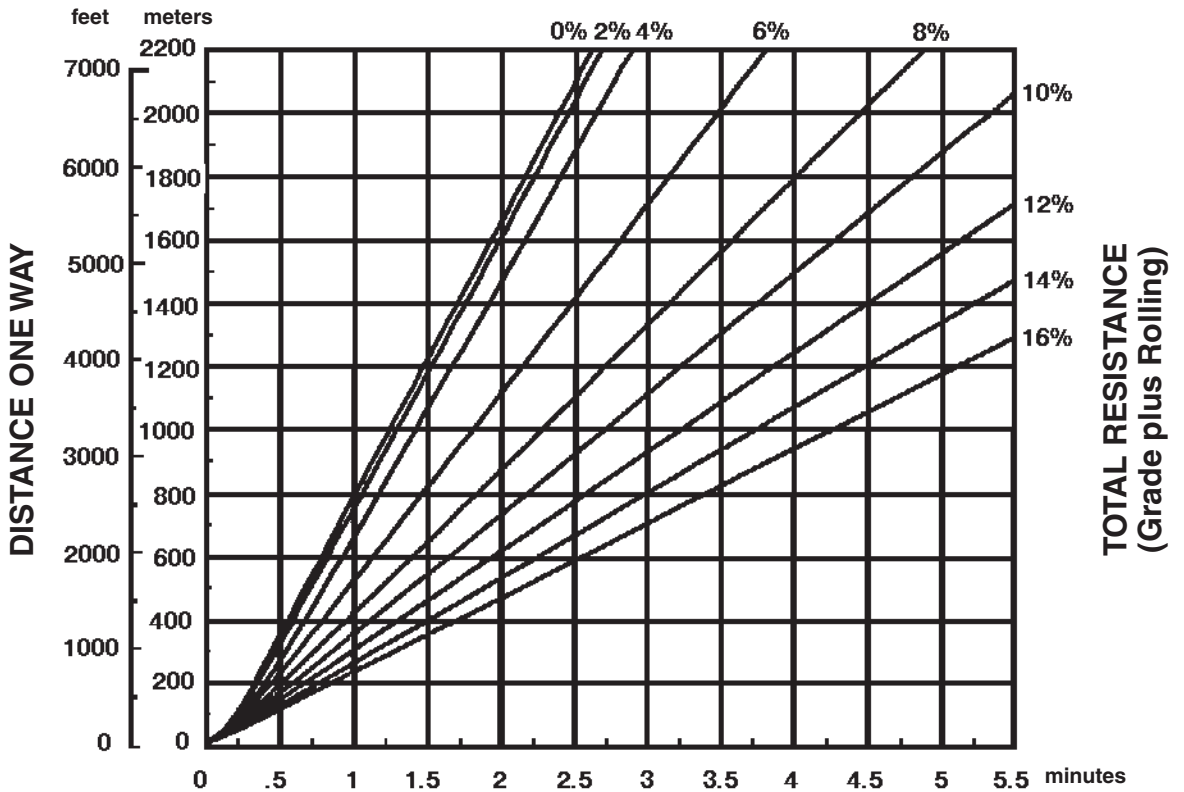

Empty weight: 33 995 kg (74,946 lb)

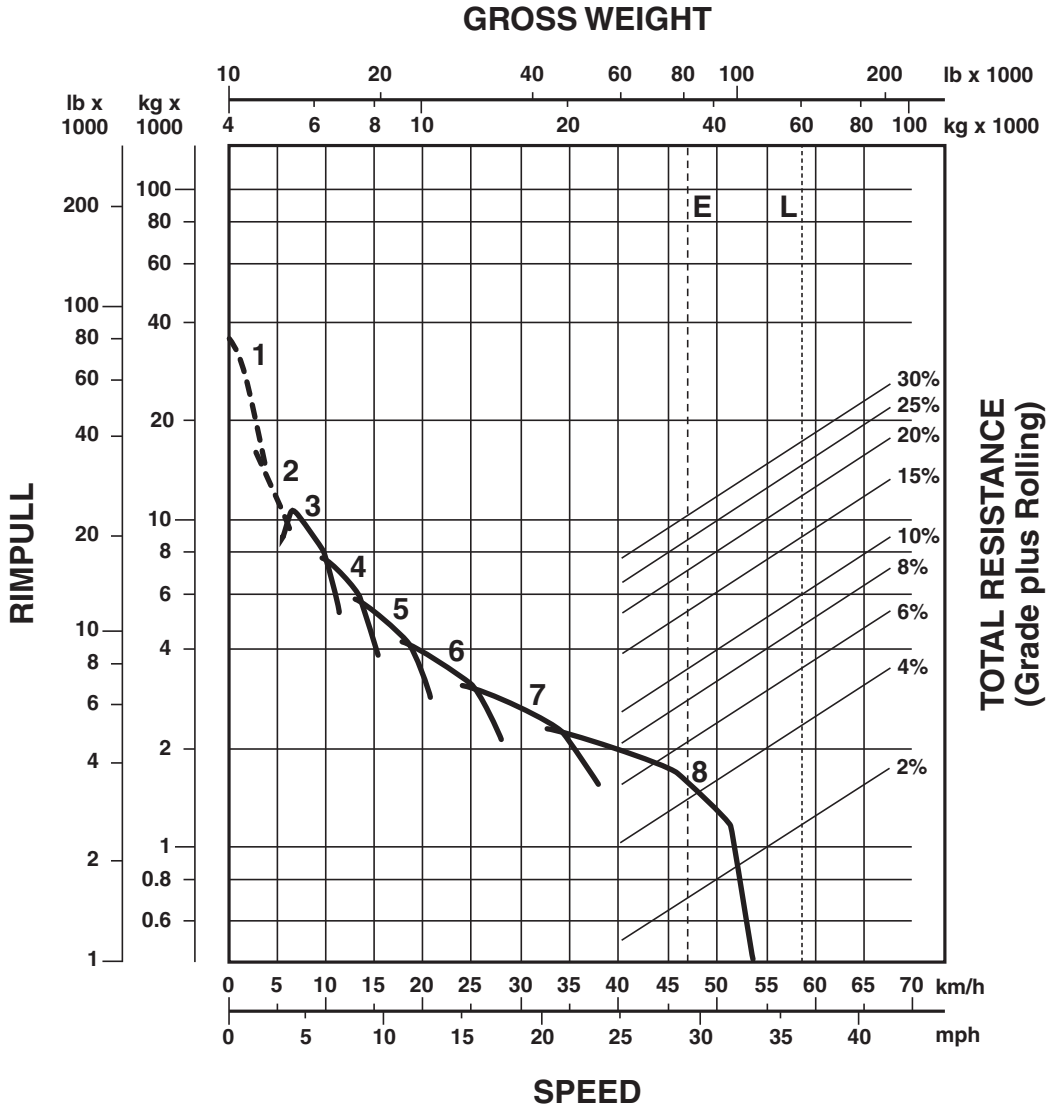

**KEY**

- 1 — 1st Gear Torque Converter Drive
- 2 — 2nd Gear Torque Converter Drive
- 3 — 3rd Gear Direct Drive
- 4 — 4th Gear Direct Drive
- 5 — 5th Gear Direct Drive
- 6 — 6th Gear Direct Drive
- 7 — 7th Gear Direct Drive
- 8 — 8th Gear Direct Drive

**KEY**

- E — Empty 37 510 kg (82,695 lb)
- L — Loaded 62 548 kg (137,895 lb)

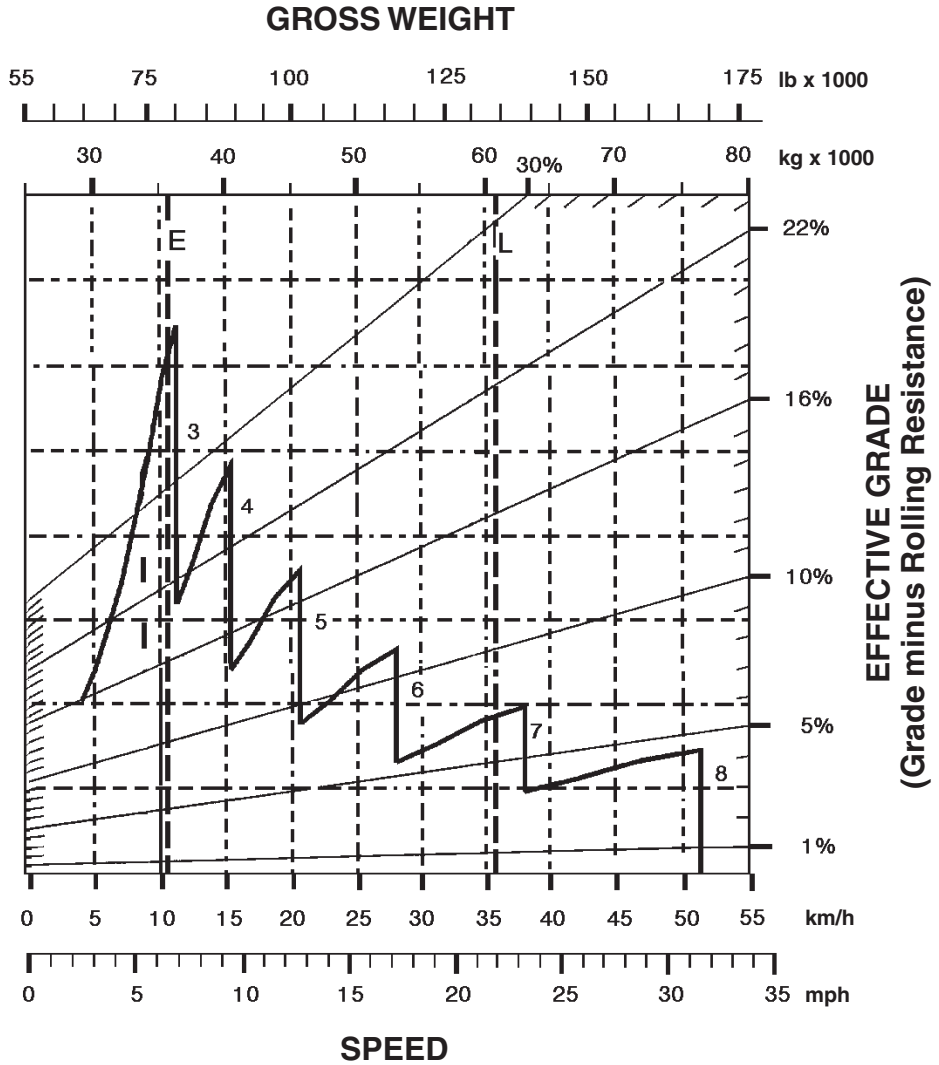

**KEY**

- 3 — 3rd Gear Direct Drive
- 4 — 4th Gear Direct Drive
- 5 — 5th Gear Direct Drive
- 6 — 6th Gear Direct Drive
- 7 — 7th Gear Direct Drive
- 8 — 8th Gear Direct Drive

**KEY**

- E — Empty 37 510 kg (82,695 lb)
- L — Loaded 62 548 kg (137,895 lb)

**LOADED**

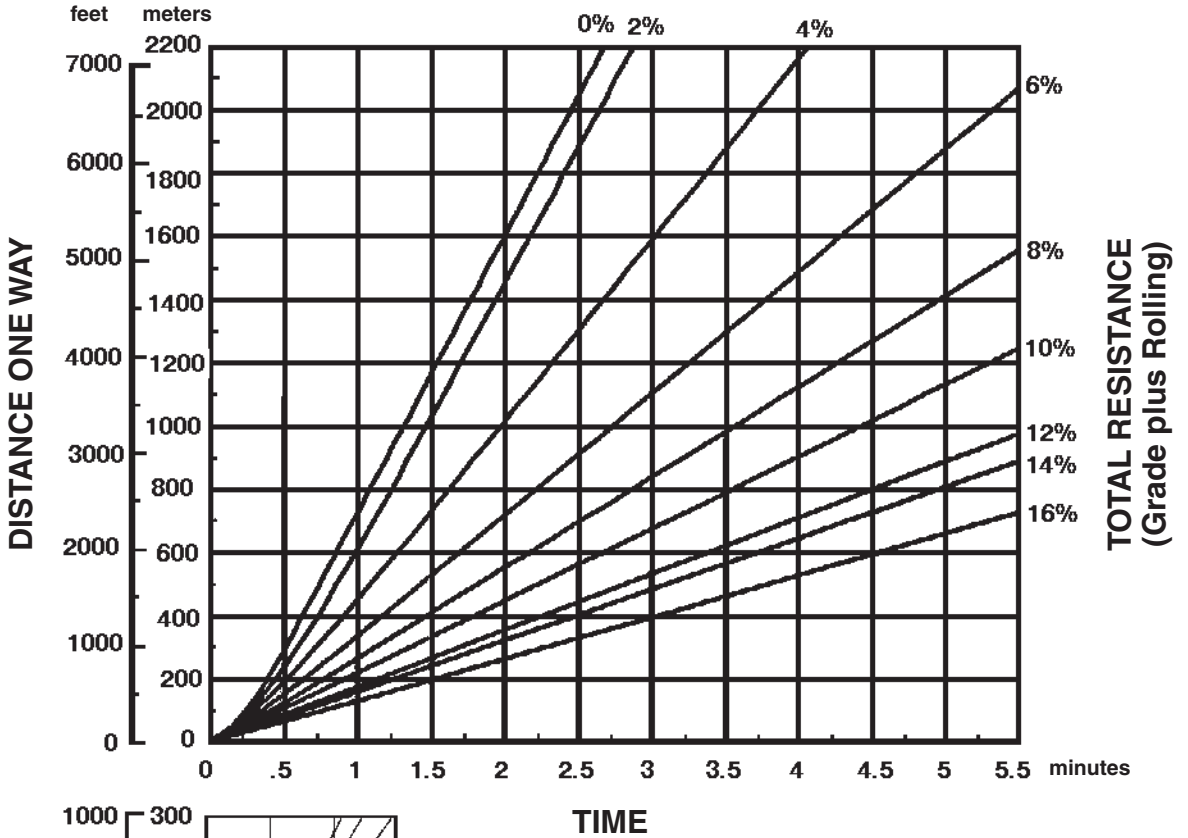

Empty weight: 37 510 kg (82,695 lb)  
 Payload: 25 038 kg (55,200 lb)

**EMPTY**

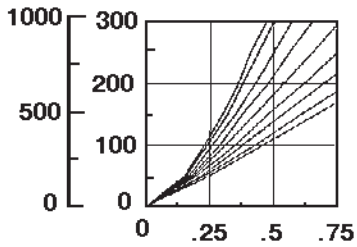
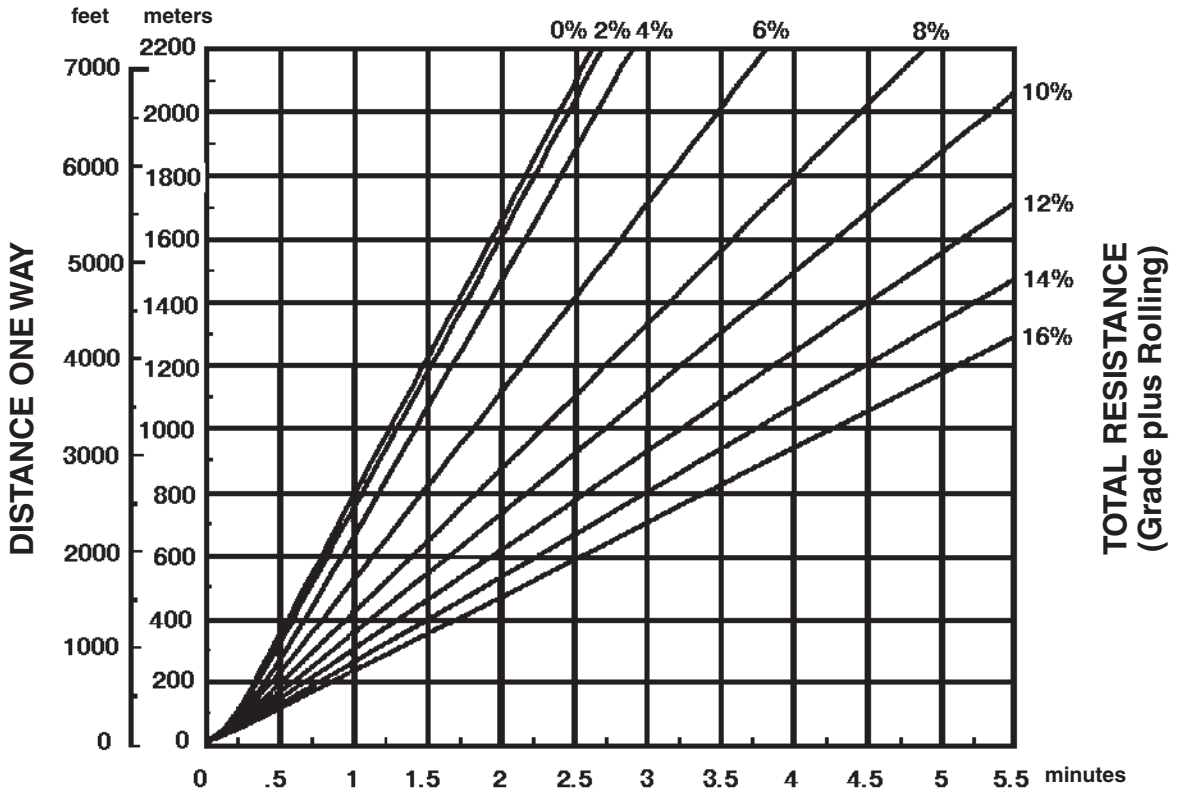

Empty weight: 37 510 kg (82,695 lb)

**TIER 3  
 STANDARD ARRANGEMENT\*  
 GROSS WEIGHT**

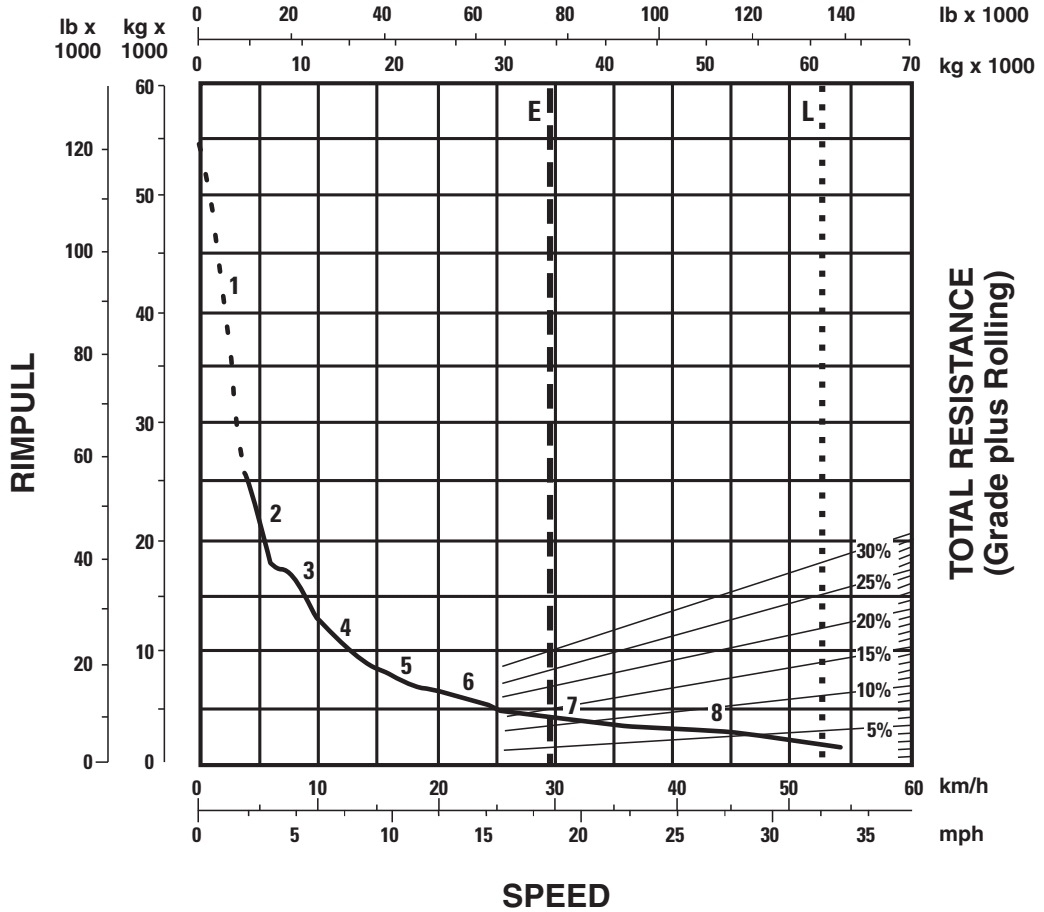

\*at sea level

**KEY**

- 1 — 1st Gear Torque Converter Drive
- 2 — 2nd Gear Torque Converter Drive
- 3 — 3rd Gear Direct Drive
- 4 — 4th Gear Direct Drive
- 5 — 5th Gear Direct Drive
- 6 — 6th Gear Direct Drive
- 7 — 7th Gear Direct Drive
- 8 — 8th Gear Direct Drive

**KEY**

- E — Empty 39 443 kg (86,957 lb)
- L — Loaded 63 393 kg (139,757 lb)



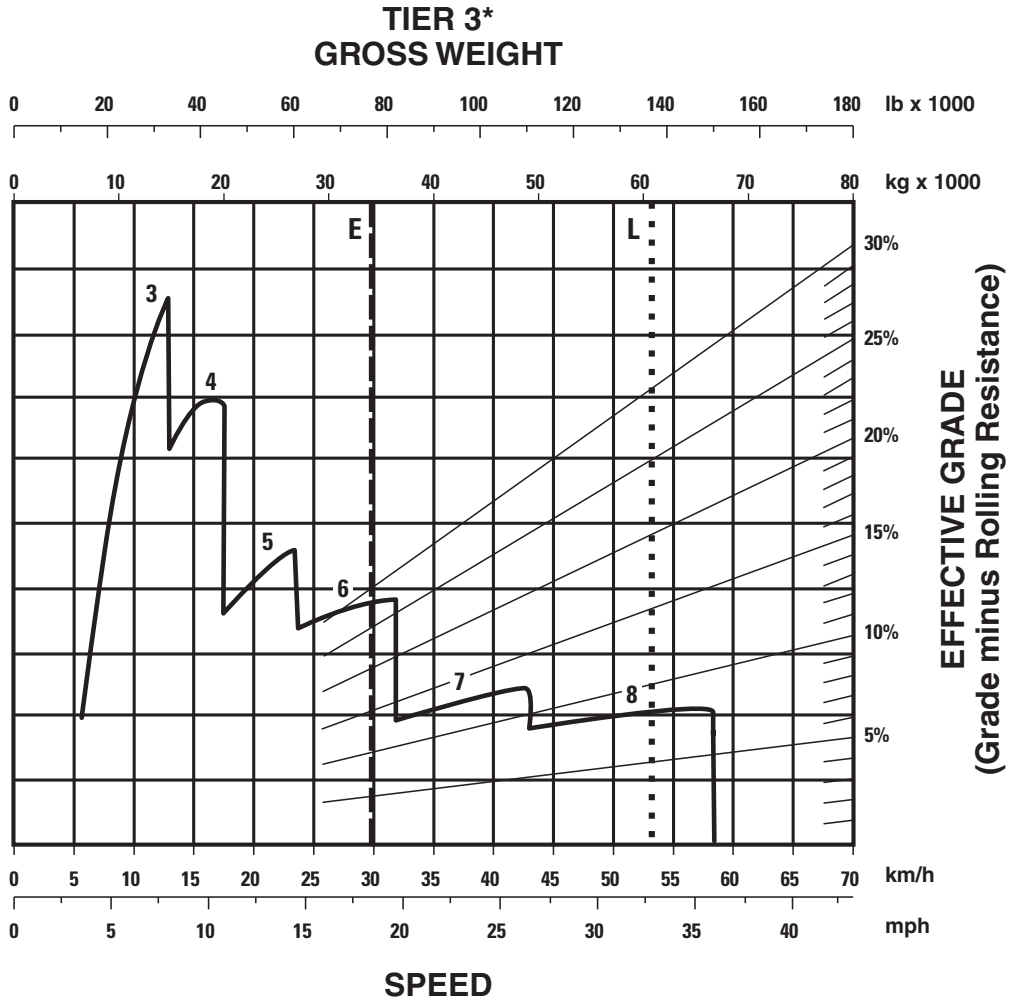

\*at sea level

**KEY**

- 3 — 3rd Gear Direct Drive
- 4 — 4th Gear Direct Drive
- 5 — 5th Gear Direct Drive
- 6 — 6th Gear Direct Drive
- 7 — 7th Gear Direct Drive
- 8 — 8th Gear Direct Drive

**KEY**

- E — Empty 39 443 kg (86,957 lb)
- L — Loaded 63 393 kg (139,757 lb)

- 33.25R29 Tires

- Standard and Push-Pull

**LOADED**

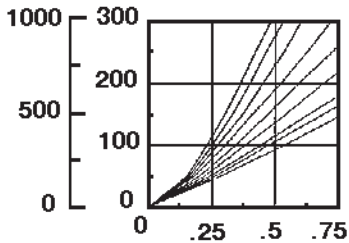
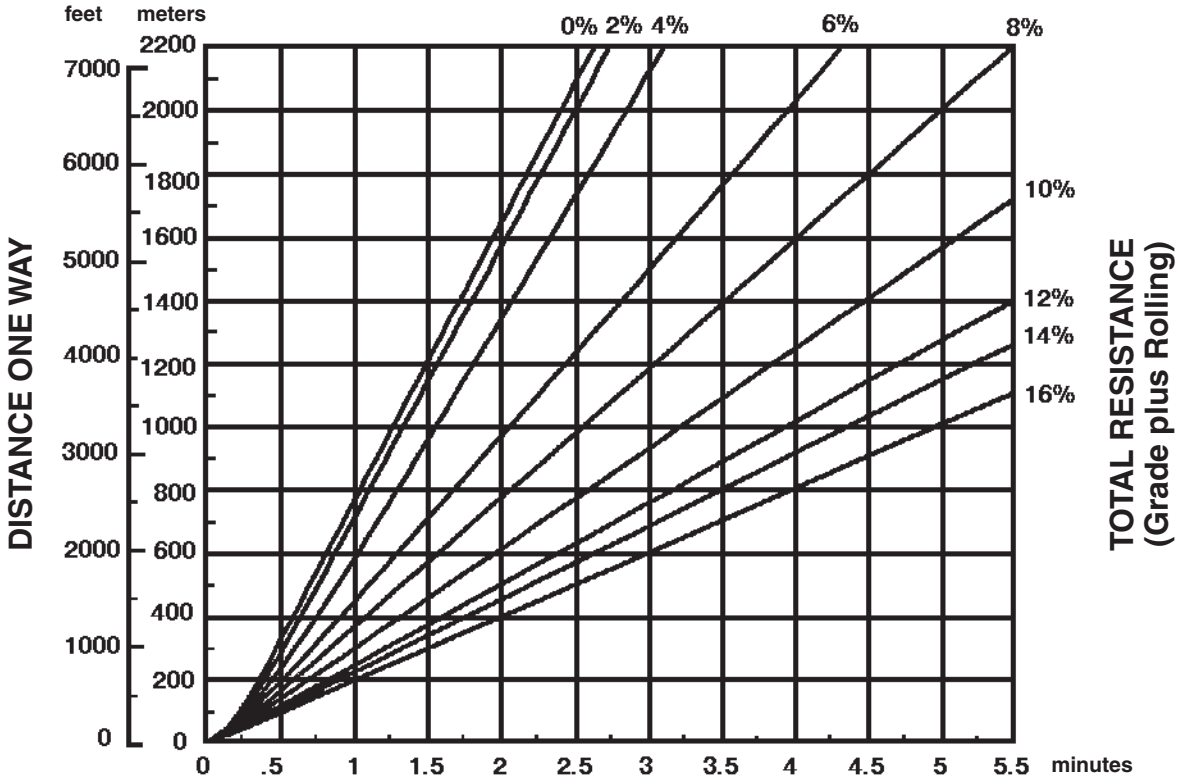

**TIME**

Empty weight: 39 443 kg (86,957 lb)

Payload: 23 950 kg (52,800 lb)

# Wheel Tractor-Scrapers

627G Travel Time — Empty

- 33.25R29 Tires
- Standard and Push-Pull

## EMPTY

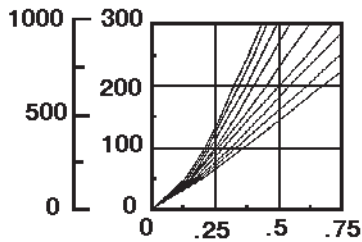
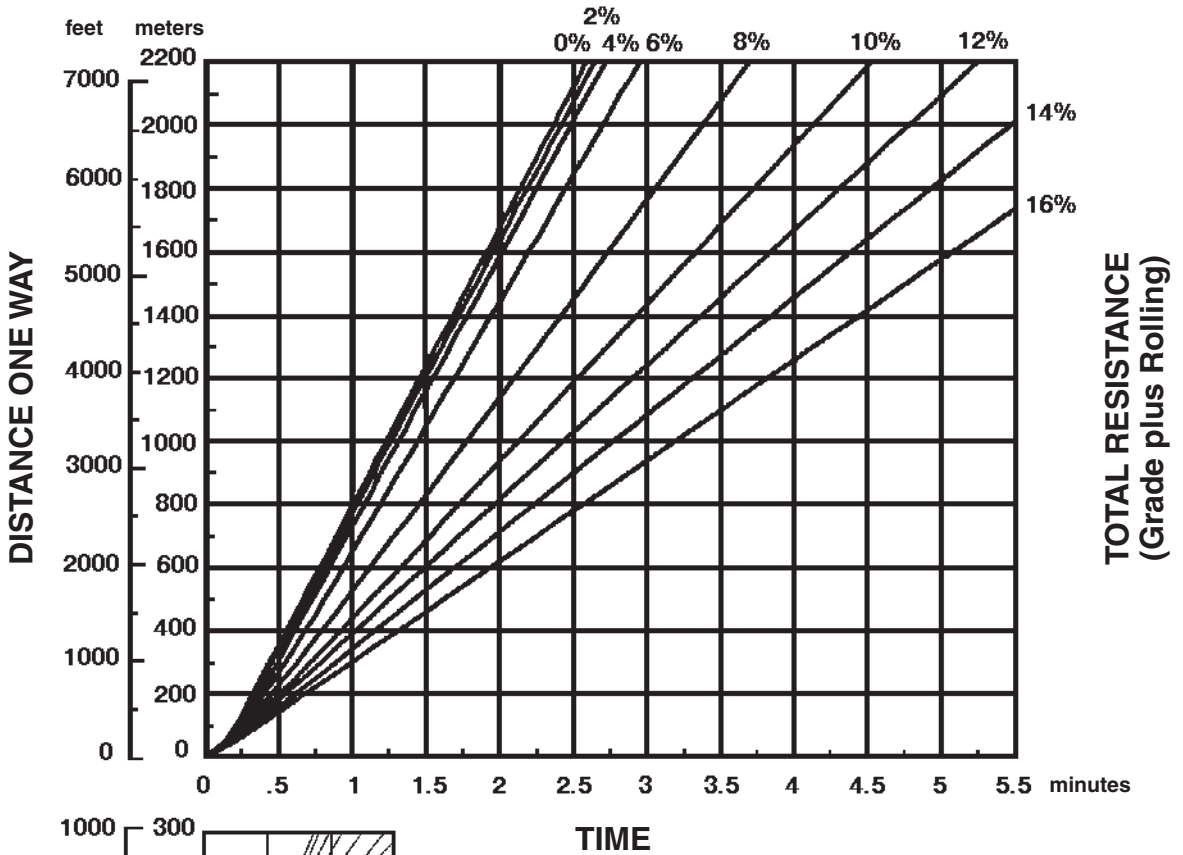

Empty weight: 39 443 kg (86,957 lb)

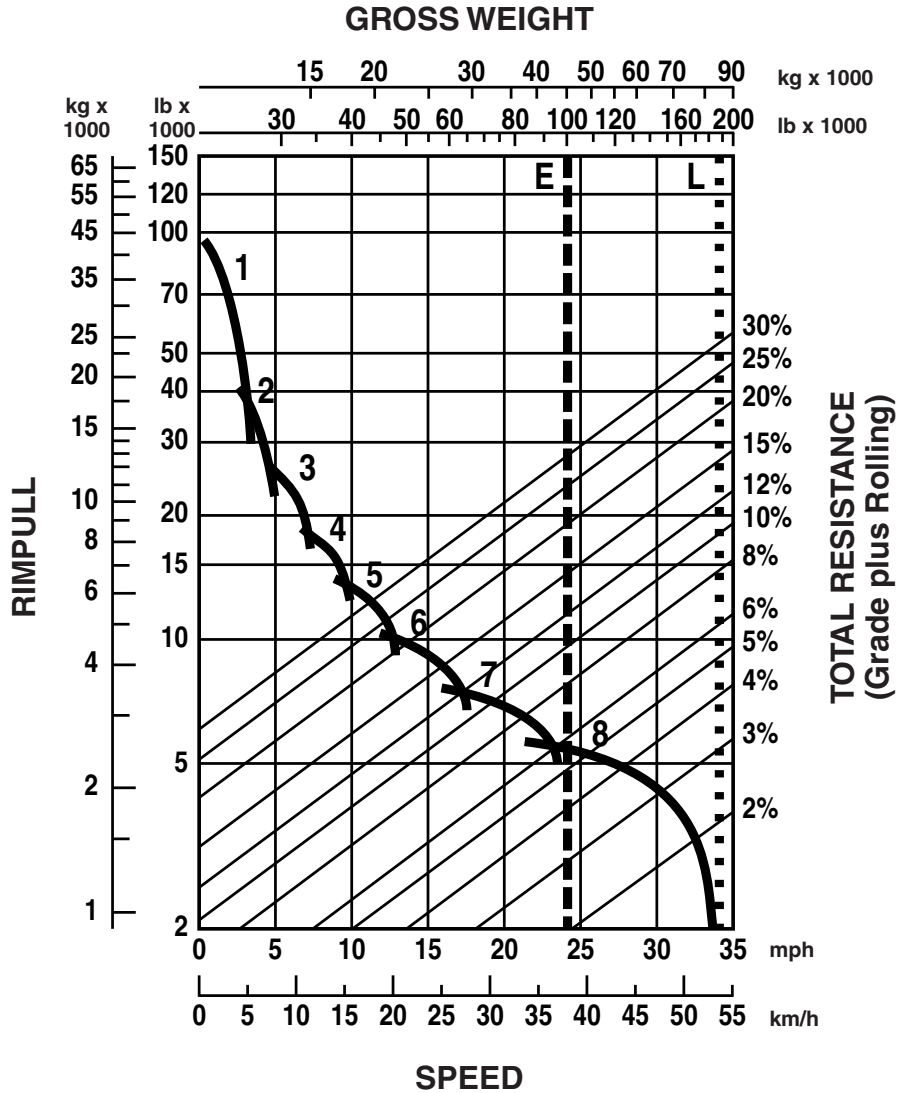

- KEY**
- 1 — 1st Gear Torque Converter Drive
  - 2 — 2nd Gear Torque Converter Drive
  - 3 — 3rd Gear Direct Drive
  - 4 — 4th Gear Direct Drive
  - 5 — 5th Gear Direct Drive
  - 6 — 6th Gear Direct Drive
  - 7 — 7th Gear Direct Drive
  - 8 — 8th Gear Direct Drive

- KEY**
- E — Empty 47 628 kg (105,002 lb)
  - L — Loaded 84 641 kg (186,602 lb)

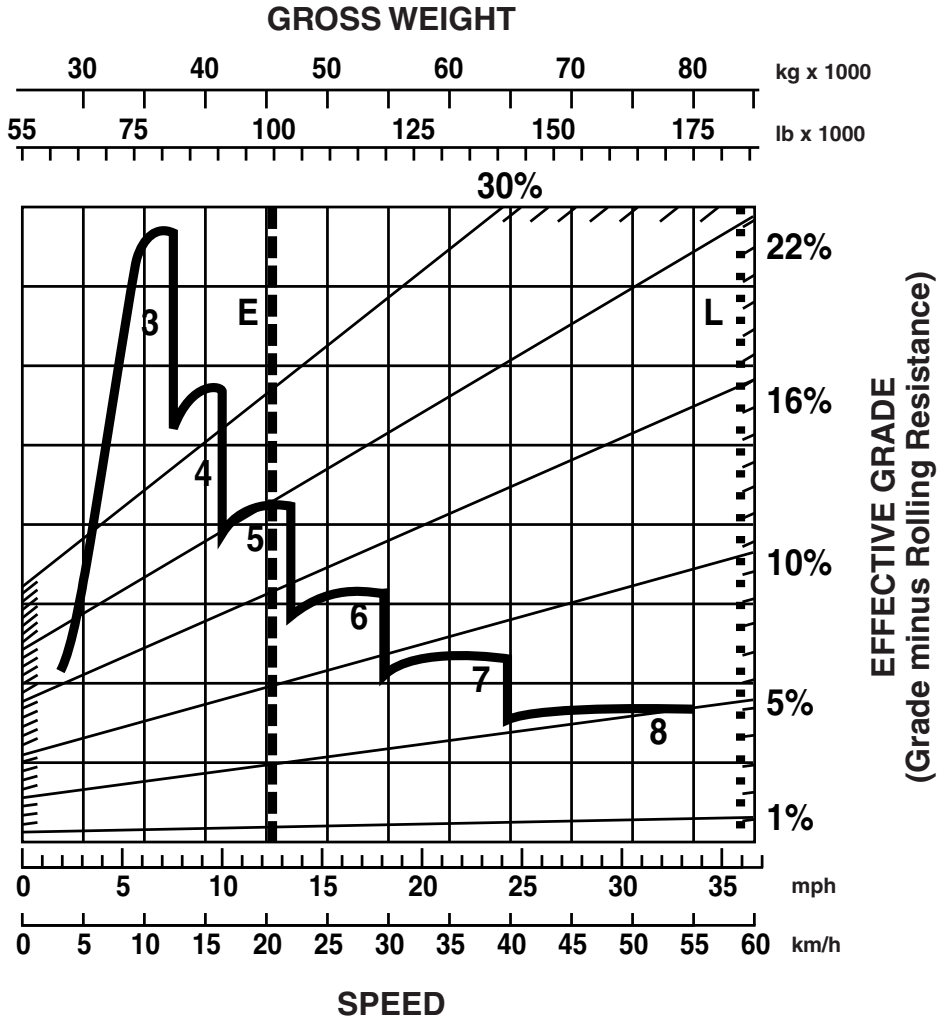

**KEY**

- 3 — 3rd Gear Direct Drive
- 4 — 4th Gear Direct Drive
- 5 — 5th Gear Direct Drive
- 6 — 6th Gear Direct Drive
- 7 — 7th Gear Direct Drive
- 8 — 8th Gear Direct Drive

**KEY**

- E — Empty 47 628 kg (105,002 lb)
- L — Loaded 84 641 kg (186,602 lb)

**LOADED**

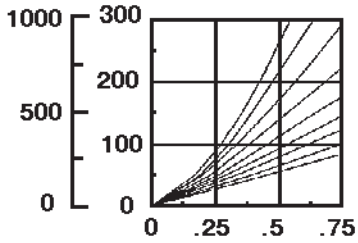
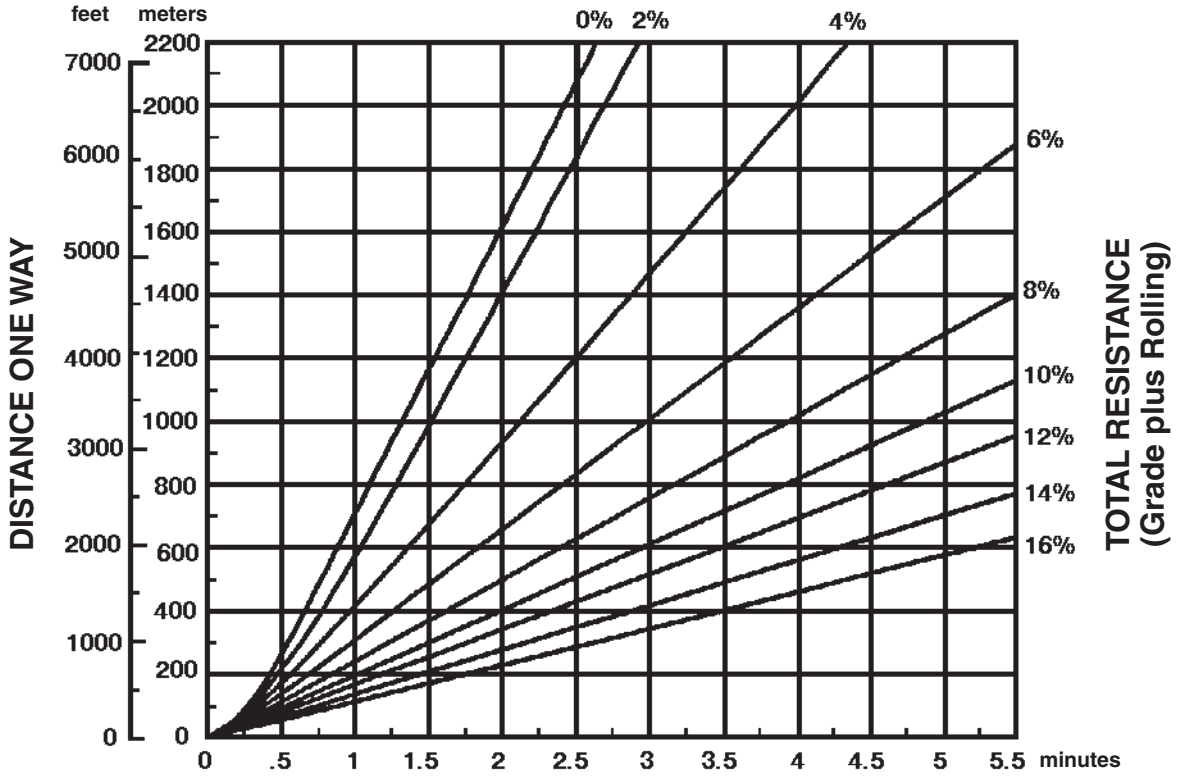

Empty weight: 47 628 kg (105,002 lb)  
 Payload: 37 013 kg (81,600 lb)

**EMPTY**

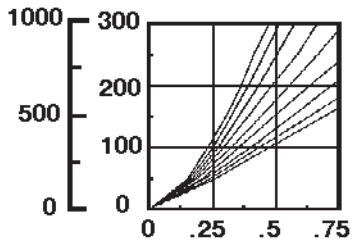
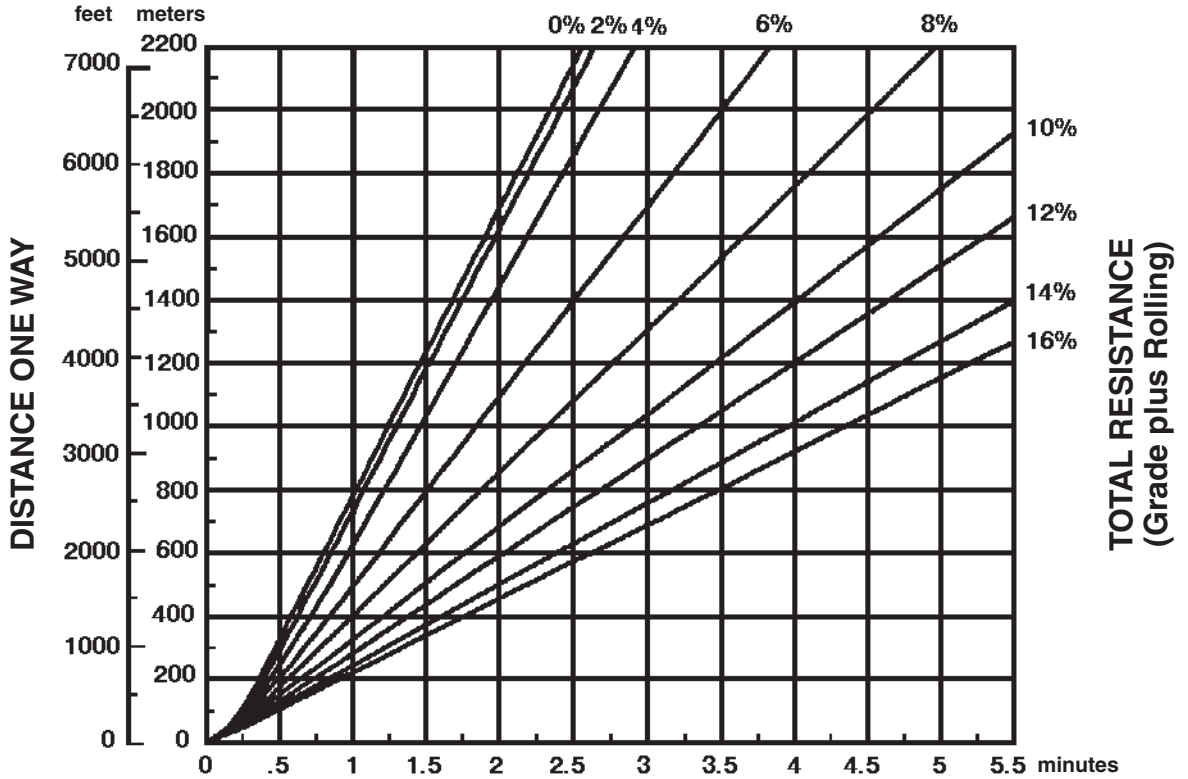

**TIME**

Empty weight: 47 628 kg (105,002 lb)

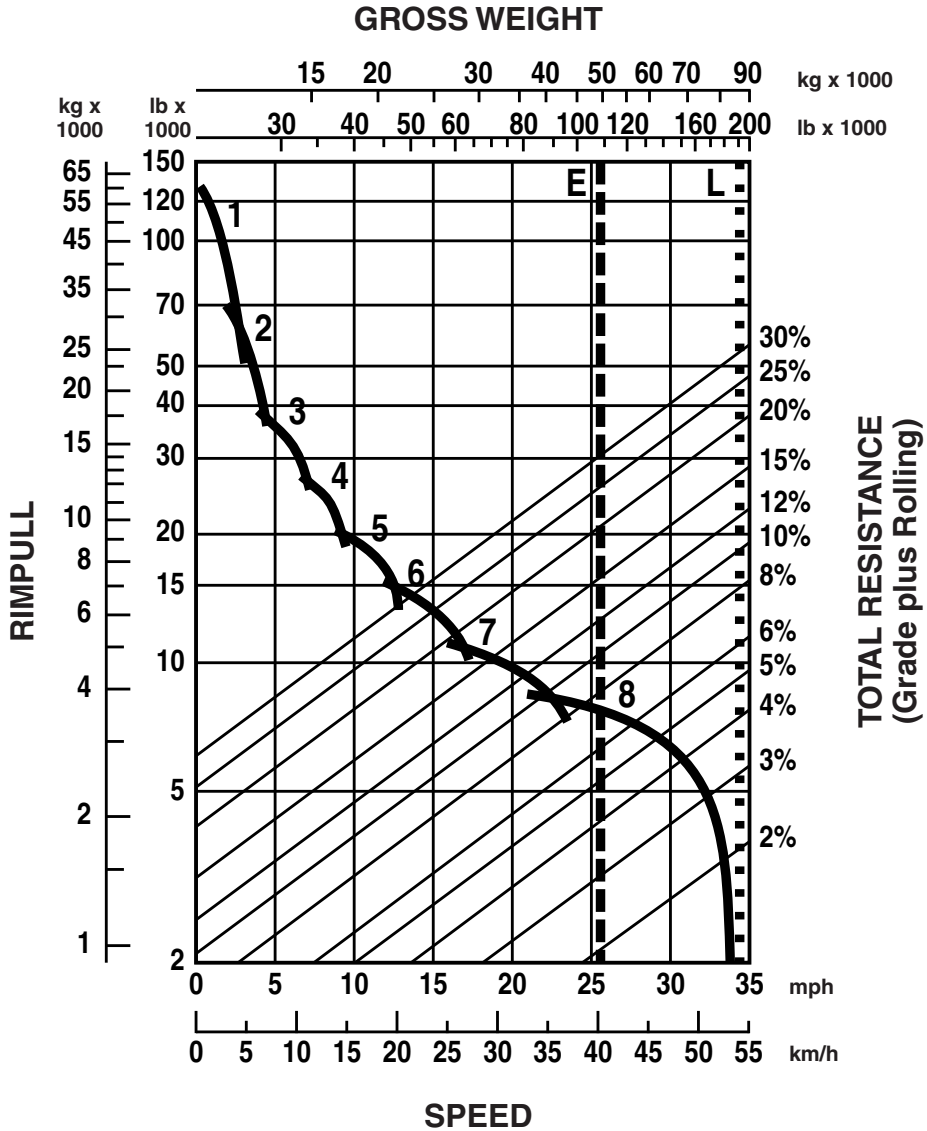



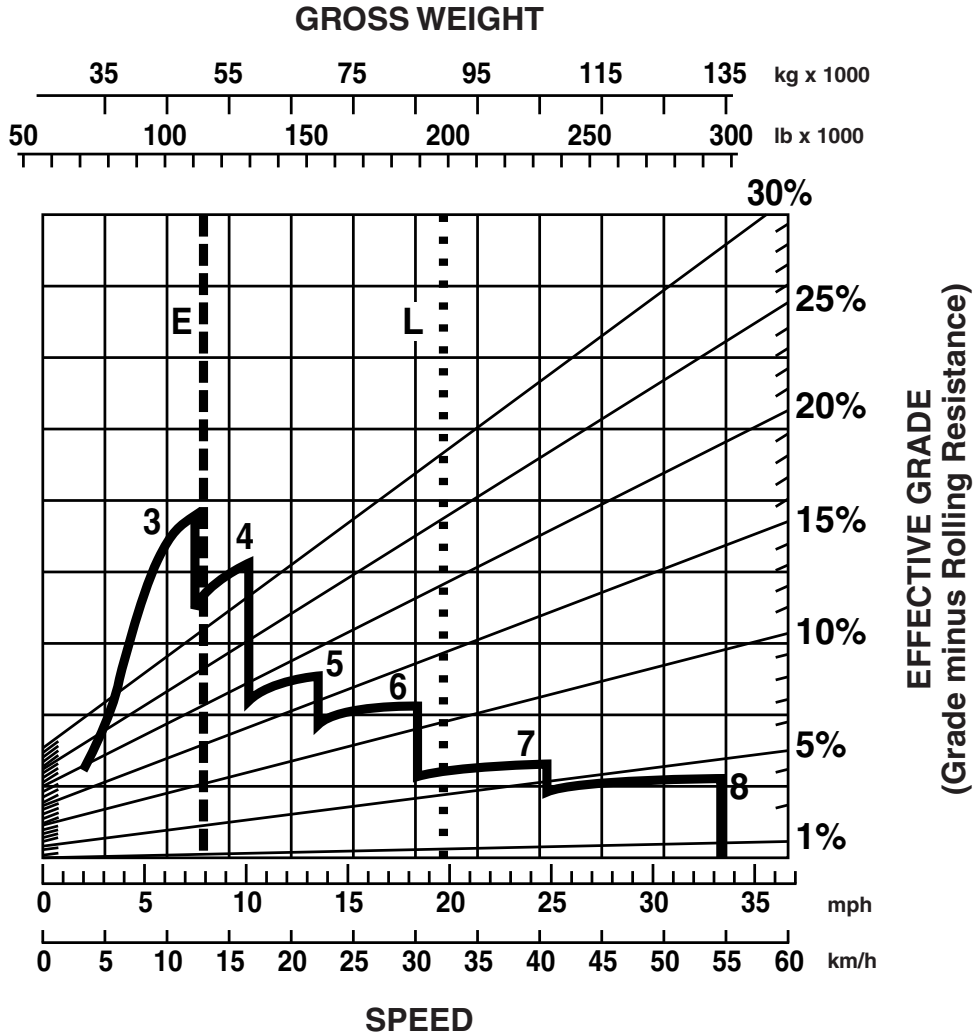

KEY

- 3 — 3rd Gear Direct Drive
- 4 — 4th Gear Direct Drive
- 5 — 5th Gear Direct Drive
- 6 — 6th Gear Direct Drive
- 7 — 7th Gear Direct Drive
- 8 — 8th Gear Direct Drive

KEY

- E — Empty 54 057 kg (119,175 lb)
- L — Loaded 91 070 kg (200,775 lb)

● 37.25R35 Tires

● Standard and Push-Pull

**LOADED**

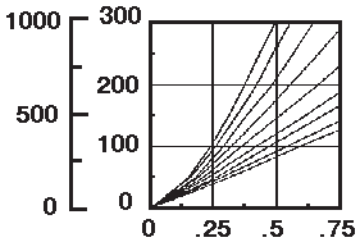
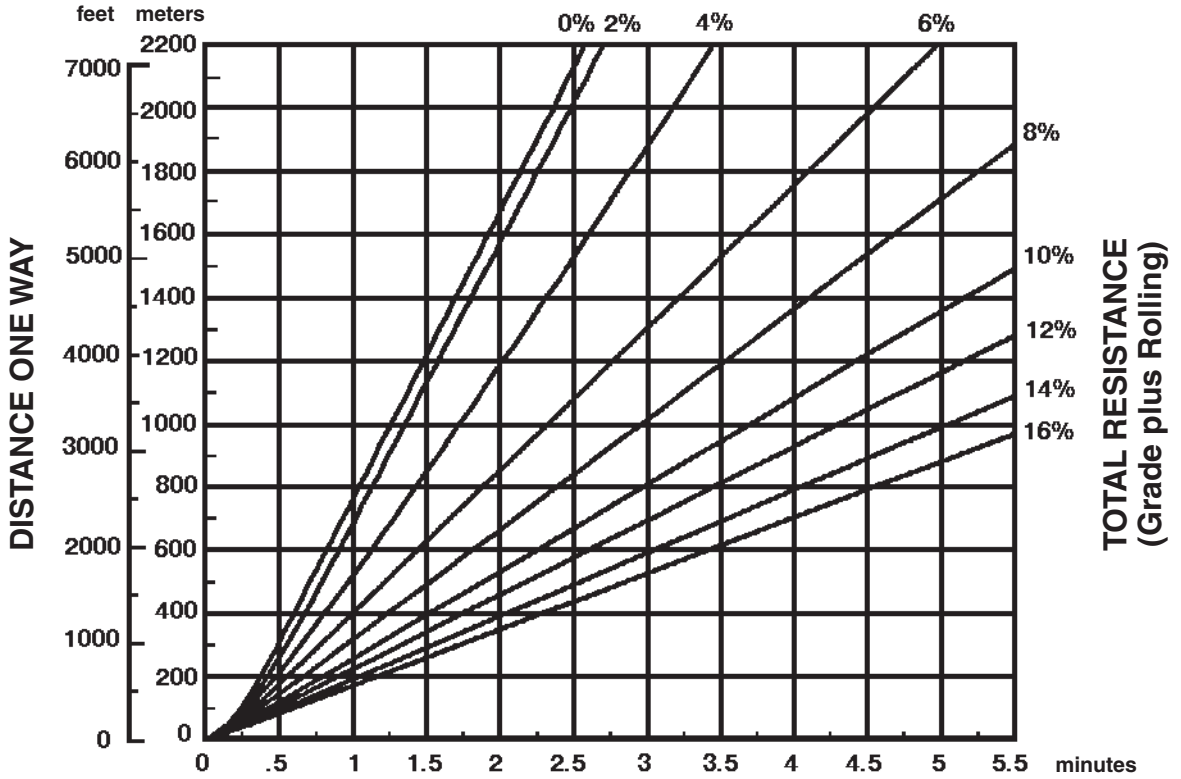

Empty weight: 54 057 kg (119,175 lb)

Payload: 37 013 kg (81,600 lb)

# Wheel Tractor-Scrapers

637G Travel Time — Empty

- 37.25R35 Tires
- Standard and Push-Pull

## EMPTY

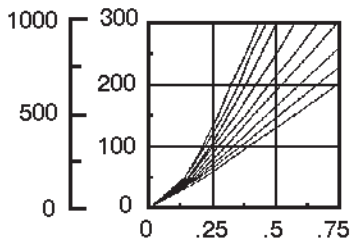
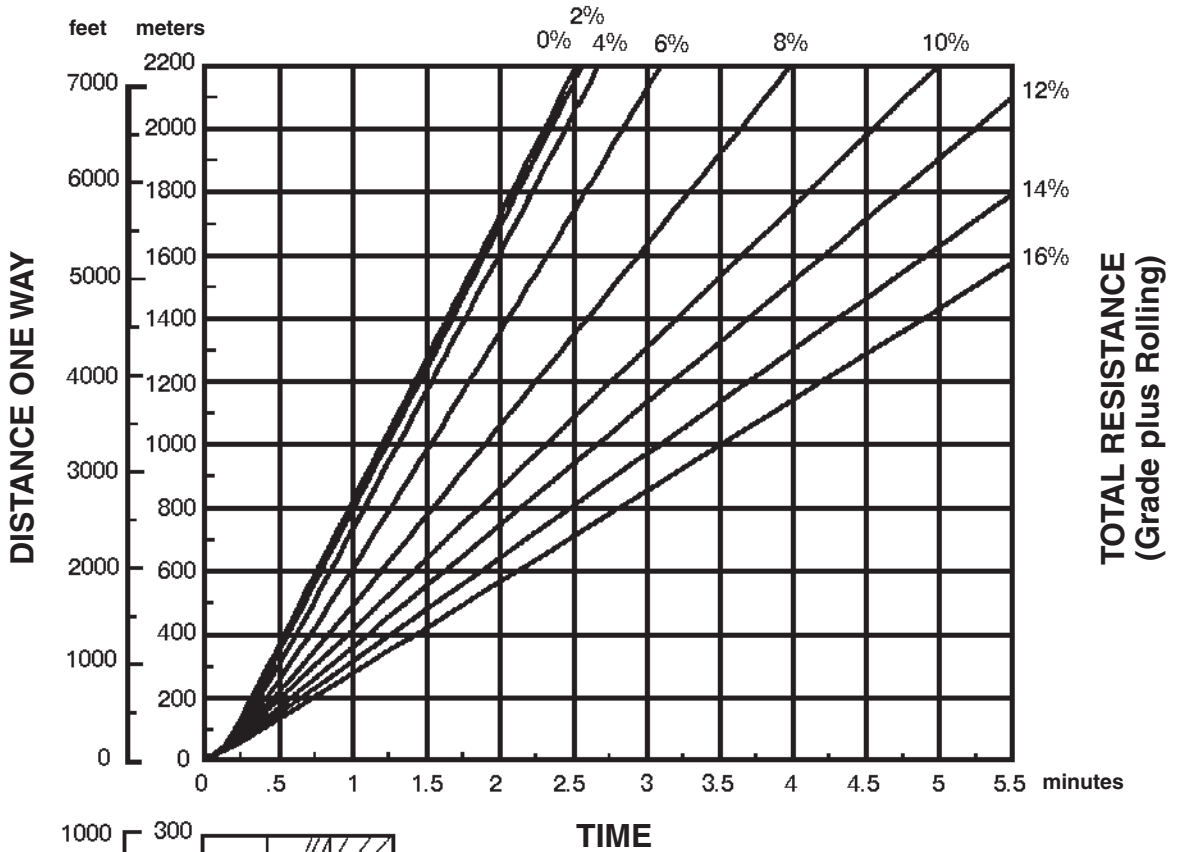

Empty weight: 54 057 kg (119,175 lb)

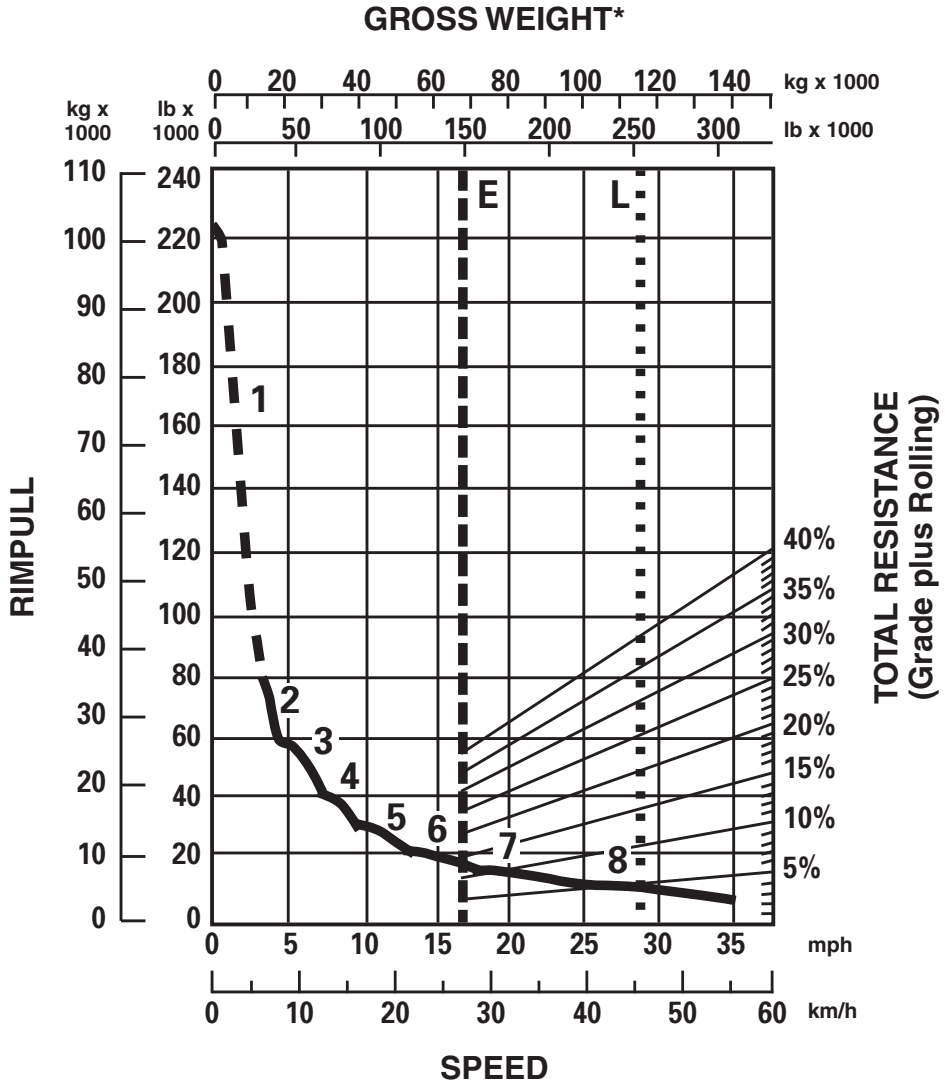

\*at sea level

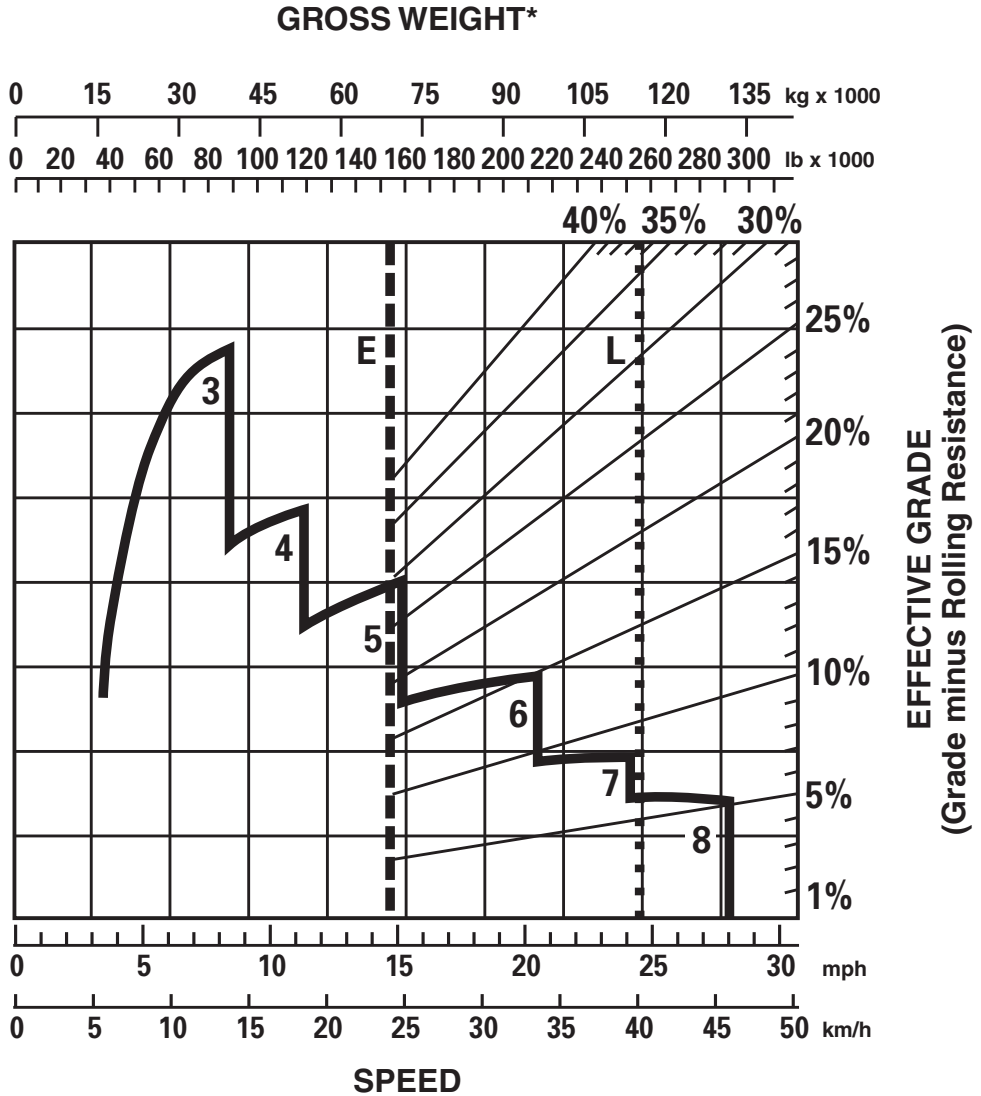

\*at sea level

**KEY**

- 3 — 3rd Gear Direct Drive
- 4 — 4th Gear Direct Drive
- 5 — 5th Gear Direct Drive
- 6 — 6th Gear Direct Drive
- 7 — 7th Gear Direct Drive
- 8 — 8th Gear Direct Drive

**KEY**

- E — Empty 72 804 kg (160,505 lb)
- L — Loaded 119 978 kg (264,505 lb)

- 40.5/75R39 Tires

- Standard and Push-Pull

**LOADED**

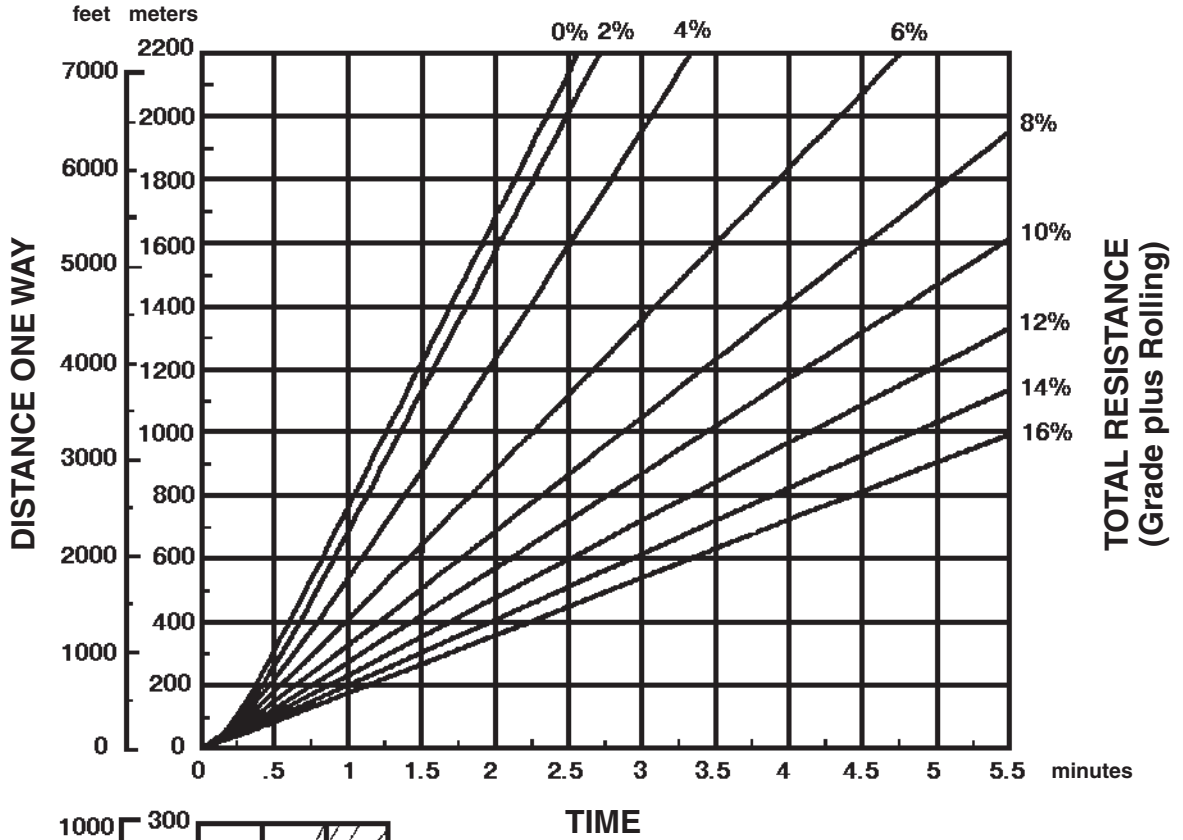

Empty weight: 72 804 kg (160,505 lb)  
Payload: 47 174 kg (104,000 lb)

# Wheel Tractor-Scrapers

657G Travel Time — Empty

- 40.5/75R39 Tires
- Standard and Push-Pull

## EMPTY

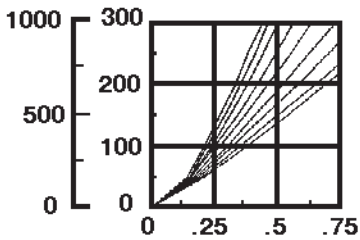
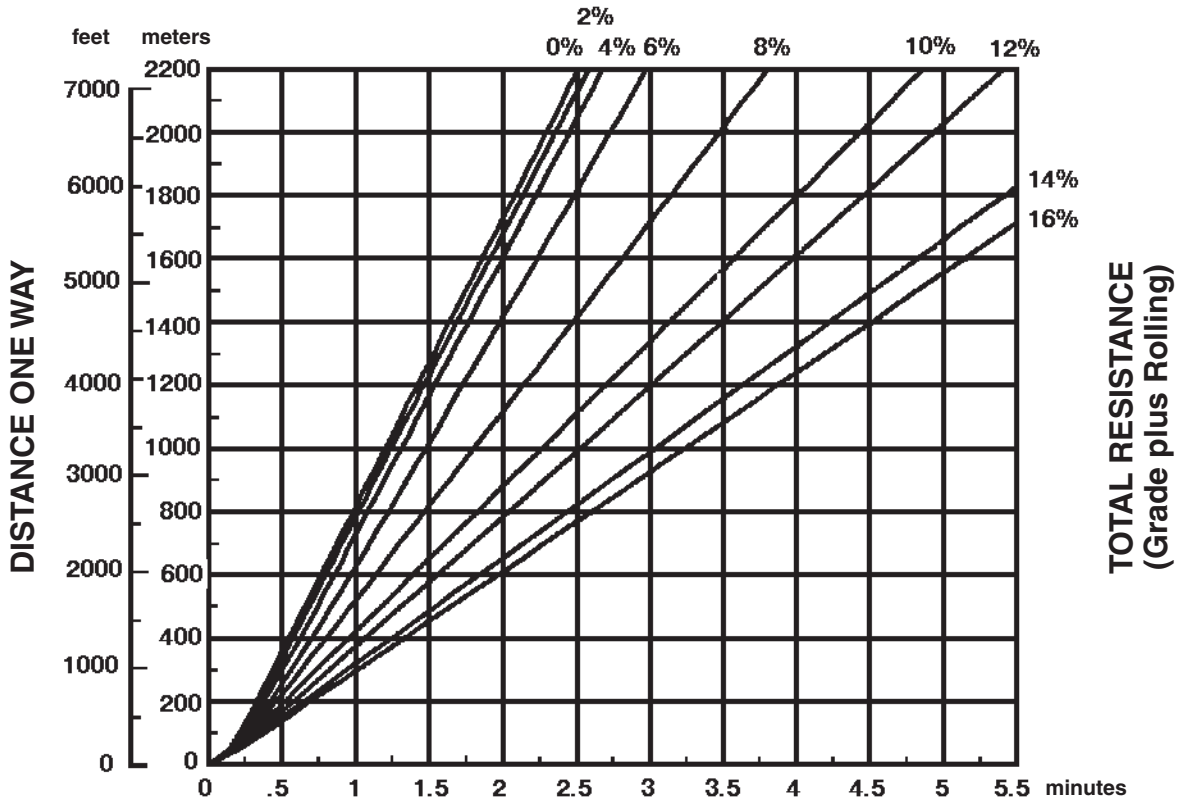

Empty weight: 72 804 kg (160,505 lb)

# TOWED SCRAPERS

## CONTENTS

### TOWED SCRAPERS

Features	.8-43
Applications	.8-43
Recommended Pull Units	.8-43
Specifications	.8-44

#### Features:

- High-strength, abrasion-resistant steel is used inside the bowl on the floor, walls, apron and ejector face for maximum strength and wear life. The bowl uses a cellular design for superior strength and dent resistance.
- Standard heavy-duty, dry-disc brake calipers ensure effective stopping from safe operating speeds.
- The bolted hitch design eliminates pin wear. The tongue's robust, straight-line design efficiently transfers maximum power to the cutting edge for outstanding performance.
- Standard radial tires provide maximum flotation and durability.
- Cat Towed Scrapers easily adapt to jobsite conditions. They can be pulled in single or tandem configurations, top loaded with an excavator, or — on an intermittent basis — be push loaded with a track-type tractor.
- Ideally suited to be pulled by Cat Track-Type Tractors and Challenger® Special Application Tractors.

#### Applications:

On any given jobsite, there are several ways to accomplish the task of hauling/moving material:

- Hydraulic excavators with articulated trucks.
- Wheel tractor-scrappers (self-loading, push loading, or push-pull loading).
- Wheel loaders with rigid-frame trucks.
- Agricultural tractors (tired or rubber tracked) with towed scrapers.
- Track-type tractors dozing material.
- Track-type tractors with towed scrapers.

Towed scrapers excel for contractors removing top soil with the following ideal conditions:

- Haul distance under 0.8 km (2500 ft).
- Materials with a bank density of less than 1780 kg/m<sup>3</sup> (3000 lb/yd<sup>3</sup>).
- No large rocks or stumps.

Towed scrapers also complement wheel tractor scrapers by expanding the work season with high flotation in the softest underfoot conditions. Adding towed scrapers to the Caterpillar product line gives contractors more solutions for selecting the earth-moving system that is most cost effective for their application. Caterpillar offers the full range of earth-moving and hauling machines — dozers, wheel tractor scrapers, towed scrapers, wheel loaders with rigid frame trucks and hydraulic excavators with articulated trucks.

#### Recommended Pull Units:

Cat Towed Scrapers are designed to be pulled by Cat Track-Type Tractors and Challenger MTS800 and MTS900 Special Application Tractors. The following tables show the minimum recommended power required for single and tandem towed scraper applications.





MODEL	TS180		TS185	
Scraper Bowl:				
Capacity — Heaped	14.8 m <sup>3</sup>	<b>18.8 yd<sup>3</sup></b>	14.5 m <sup>3</sup>	<b>19.0 yd<sup>3</sup></b>
Width of Cut, to Router Bits	3200 mm	<b>10.5 ft</b>	3785 mm	<b>12.4 ft</b>
Rated Load	20 800 kg	<b>45,900 lb</b>	21 050 kg	<b>46,400 lb</b>
Capacity Struck	9.9 m <sup>3</sup>	<b>13 yd<sup>3</sup></b>	11 m <sup>3</sup>	<b>14.4 yd<sup>3</sup></b>
Depth of Cut — Maximum	203 mm	<b>8 in</b>	305 mm	<b>12 in</b>
Ground Clearance — Maximum	533 mm	<b>21 in</b>	597 mm	<b>23.5 in</b>
Cutting Edge — Thickness	22 mm	<b>0.87 in</b>	22 mm	<b>0.87 in</b>
Depth of Spread — Maximum	610 mm	<b>24 in</b>	711.2 mm	<b>28 in</b>
Apron Opening	1600 mm	<b>63 in</b>	1600 mm	<b>63 in</b>
Weights:				
Empty Weight	11 748 kg	<b>25,900 lb</b>	11 748 kg	<b>32,020 lb</b>
Distribution, Empty — Tongue		<b>28%</b>		<b>28%</b>
— Axle		<b>72%</b>		<b>72%</b>
Distribution, Loaded — Tongue		<b>29%</b>		<b>29%</b>
— Axle		<b>71%</b>		<b>71%</b>
Brakes and Tires:				
Brake Type		<b>Dry-Disc</b>		<b>Dry-Disc</b>
Calipers, Lead — Qty		<b>2 per side</b>		<b>2 per side</b>
Calipers, Trail — Qty		<b>1 per side</b>		<b>1 per side</b>
Tires — Qty		<b>2</b>		<b>4</b>
Tire — Standard		<b>29.5R25</b>		<b>23.5R25</b>
Optional		<b>875 65R29</b>		<b>26.5R25</b>
Dimensions:				
Width — Inside of Bowl	3048 mm	<b>120 in</b>	3632 mm	<b>143 in</b>
— Outside Rear Rires	3099 mm	<b>122 in</b>	3835 mm	<b>151 in</b>
— Outside Bowl	3378 mm	<b>133 in</b>	3988 mm	<b>157 in</b>
Height — Overall Shipping	2362 mm	<b>93 in</b>	2515 mm	<b>99 in</b>
— Floor to Top of Ejector	1930 mm	<b>76 in</b>	1930 mm	<b>76 in</b>
— Sidewall	1219 mm	<b>48 in</b>	1219 mm	<b>48 in</b>
— Ground to Cutting Edge — Maximum	657 mm	<b>25.9 in</b>	687 mm	<b>27.0 in</b>
Length — Maximum	8915 mm	<b>351 in</b>	9119 mm	<b>359 in</b>
— Floor	1295 mm	<b>51 in</b>	1219 mm	<b>48 in</b>
Hydraulics:				
Front Bowl Cylinder — Bore	127 mm	<b>5 in</b>	127 mm	<b>5 in</b>
— Stroke	508 mm	<b>20 in</b>	508 mm	<b>20 in</b>
Rear Bowl Cylinder — Bore		<b>N/A</b>	127 mm	<b>5 in</b>
— Stroke		<b>N/A</b>	203 mm	<b>8 in</b>
Apron Cylinder — Bore	102 mm	<b>4 in</b>	102 mm	<b>4 in</b>
— Stroke	813 mm	<b>32 in</b>	965 mm	<b>38 in</b>
Ejector Cylinder — Bore	127 mm	<b>5 in</b>	127 mm	<b>5 in</b>
— Stroke	1372 mm	<b>54 in</b>	914 mm	<b>36 in</b>
Pull Unit Recommendations:				
Steel Track-Type Tractor — Single Scraper		<b>D7</b>		<b>D8</b>
— Tandem Scrapers		<b>D8</b>		<b>D9</b>
Rubber Tracked Ag Tractor — Single Scraper	224-298 kW	<b>300-400 hp</b>	298-373 kW	<b>400-500 hp</b>
— Tandem Scrapers	298-373 kW	<b>400-500 hp</b>	373-447 kW	<b>500-600 hp</b>
Rubber Tired Ag Tractor — Single Scraper	224-298 kW	<b>300-400 hp</b>	298-373 kW	<b>400-500 hp</b>
— Tandem Scrapers	298-373 kW	<b>400-500 hp</b>	373-447 kW	<b>500-600 hp</b>
Hydraulic Services Required — Single Scraper		<b>2</b>		<b>3</b>
— Tandem Scraper		<b>4</b>		<b>6</b>



MODEL	TS220		TS225	
Scraper Bowl:				
Capacity — Heaped	18.0 m <sup>3</sup>	<b>23.5 yd<sup>3</sup></b>	18.0 m <sup>3</sup>	<b>23.5 yd<sup>3</sup></b>
Width of Cut, to Router Bits	3480 mm	<b>11.4 ft</b>	3785 mm	<b>12.4 ft</b>
Rated Load	25 580 kg	<b>56,400 lb</b>	25 580 kg	<b>56,400 lb</b>
Capacity Struck	13 m <sup>3</sup>	<b>17 yd<sup>3</sup></b>	13 m <sup>3</sup>	<b>17 yd<sup>3</sup></b>
Depth of Cut — Maximum	262 mm	<b>10.3 in</b>	262 mm	<b>10.3 in</b>
Ground Clearance — Maximum	508 mm	<b>20 in</b>	660 mm	<b>26 in</b>
Cutting Edge — Thickness	22 mm	<b>0.87 in</b>	22 mm	<b>0.87 in</b>
Depth of Spread — Maximum	737 mm	<b>29 in</b>	737 mm	<b>29 in</b>
Apron Opening	1600 mm	<b>63 in</b>	1600 mm	<b>63 in</b>
Weights:				
Empty Weight	13 145 kg	<b>28,980 lb</b>	15 250 kg	<b>33,620 lb</b>
Distribution, Empty — Tongue		<b>28%</b>		<b>28%</b>
— Axle		<b>72%</b>		<b>72%</b>
Distribution, Loaded — Tongue		<b>29%</b>		<b>29%</b>
— Axle		<b>71%</b>		<b>71%</b>
Brakes and Tires:				
Brake Type	<b>Dry-Disc</b>		<b>Dry-Disc</b>	
Calipers, Lead — Qty	<b>2 per side</b>		<b>2 per side</b>	
Calipers, Trail — Qty	<b>2 per side</b>		<b>2 per side</b>	
Tires — Qty	<b>2</b>		<b>4</b>	
Tire — Standard	<b>875 65R29</b>		<b>26.5R25</b>	
— Optional	<b>N/A</b>		<b>N/A</b>	
Dimensions:				
Width — Inside of Bowl	3353 mm	<b>132 in</b>	3632 mm	<b>143 in</b>
— Outside Rear Rires	3378 mm	<b>133 in</b>	3912 mm	<b>154 in</b>
— Outside Bowl	3683 mm	<b>145 in</b>	3988 mm	<b>157 in</b>
Height — Overall Shipping	2464 mm	<b>97 in</b>	2515 mm	<b>99 in</b>
— Floor to Top of Ejector	2134 mm	<b>84 in</b>	1930 mm	<b>76 in</b>
— Sidewall	1219 mm	<b>48 in</b>	1219 mm	<b>48 in</b>
— Ground to Cutting Edge — Maximum	698 mm	<b>27.5 in</b>	819 mm	<b>31.9 in</b>
Length — Maximum	9677 mm	<b>381 in</b>	10287 mm	<b>405 in</b>
— Floor	1448 mm	<b>57 in</b>	1346 mm	<b>53 in</b>
Hydraulics:				
Front Bowl Cylinder — Bore	140 mm	<b>5.5 in</b>	140 mm	<b>5.5 in</b>
— Stroke	508 mm	<b>20 in</b>	508 mm	<b>20 in</b>
Rear Bowl Cylinder — Bore		<b>N/A</b>	152 mm	<b>6 in</b>
— Stroke		<b>N/A</b>	203 mm	<b>8 in</b>
Apron Cylinder — Bore	102 mm	<b>4 in</b>	102 mm	<b>4 in</b>
— Stroke	965 mm	<b>38 in</b>	965 mm	<b>38 in</b>
Ejector Cylinder — Bore	127 mm	<b>5 in</b>	127 mm	<b>5 in</b>
— Stroke	1524 mm	<b>60 in</b>	1219 mm	<b>48 in</b>
Pull Unit Recommendations:				
Steel Track-Type Tractor — Single Scraper		<b>D8</b>		<b>D8</b>
— Tandem Scrapers		<b>D10</b>		<b>D10</b>
Rubber Tracked Ag Tractor — Single Scraper	298-373 kW	<b>400-500 hp</b>	298-373 kW	<b>400-500 hp</b>
— Tandem Scrapers	373-447 kW	<b>500-600 hp</b>	373-447 kW	<b>500-600 hp</b>
Rubber Tired Ag Tractor — Single Scraper	298-373 kW	<b>400-500 hp</b>	298-373 kW	<b>400-500 hp</b>
— Tandem Scrapers	373-447 kW	<b>500-600 hp</b>	298-373 kW	<b>500-600 hp</b>
Hydraulic Services Required — Single Scraper		<b>2</b>		<b>3</b>
— Tandem Scraper		<b>4</b>		<b>6</b>

<b>Pull Unit</b>	<b>Hauling Distance</b>	<b>Materials</b>
Cat Track-Type Tractors	250-300 m <b>(800-1000 ft)</b>	Soil, dirt and small rock, sand and shale (no shot rock)
Challenger MT800 Series Tractors	Up to 915 m <b>(3000 ft)</b>	Soil, sand and gravel mix
Challenger MT900 Series Tractors	Up to 1215 m <b>(4000 ft)</b>	

**TS180 Recommended Pull Units**

<b>Configuration</b>	<b>Track-Type Tractor</b>	<b>Ag Tractor</b>
Single	D7	224-298 kW <b>(300-400 hp)</b>
Tandem	D8	298-373 kW <b>(400-500 hp)</b>

# CONSTRUCTION & MINING TRUCKS

## CONTENTS

Features	9-1
Truck Specifications	9-3
Tire Specifications	9-12
Use of Brake Performance Curves	9-13
Fixed Times for Hauling Units	9-13
Mechanical Power Train Efficiencies	9-14
Curves:	
770 Rimpull-Speed-Gradeability, Brake Performance, Travel Time	9-15
772 Rimpull-Speed-Gradeability, Brake Performance, Travel Time	9-19
773E Rimpull-Speed-Gradeability, Brake Performance, Travel Time	9-23
773F Rimpull-Speed-Gradeability, Brake Performance, Travel Time	9-27
775F Rimpull-Speed-Gradeability, Brake Performance, Travel Time	9-31
777D Rimpull-Speed-Gradeability, Brake Performance, Travel Time	9-35
777F Rimpull-Speed-Gradeability, Brake Performance, Travel Time	9-39
785C Rimpull-Speed-Gradeability, Brake Performance, Travel Time	9-43
785D Rimpull-Speed-Gradeability, Brake Performance, Travel Time	9-47
789C Rimpull-Speed-Gradeability, Brake Performance, Travel Time	9-51
793D Rimpull-Speed-Gradeability, Brake Performance, Travel Time	9-55
793F Rimpull-Speed-Gradeability, Brake Performance, Travel Time	9-64
797F Rimpull-Speed-Gradeability, Brake Performance, Travel Time	9-70

## Features:

- **Cat Four-Stroke Diesel Engines** — Turbo-charged, aftercooled, adjustment-free fuel system (direct injection).
- **Electronically-Controlled Automatic Transmission** — Speed sensing device automatically shifts transmission between 1st and gear selected by operator.
- **Truck Production Management System (TPMS) (option)** — Utilizes strut pressure sensors and an on-board microprocessor to determine payload weight, cycle segment times, delay times, actual clock time and date of each cycle.
- **VIMS™** — Monitors all vital machine functions. Keeps operator informed of current machine operating conditions, helps reduce downtime and allows service personnel easy access to data for fast accurate diagnosis. VIMS includes the Truck Production Management System.  
  
On Quarry and Construction Trucks VIMS is an option on 773F-777F and not available on 770-772, 773E or 777D. On Large Mining Trucks VIMS is standard on current production 785C through 797F.
- **Mechanical Electronic Unit Injection (MEUI)** in the 770 through 793D — Electronically maintains fuel settings, provides automatic altitude and air filter restriction compensation, and features automatic variable timing, improved diagnostics and increased fuel efficiency.
- **Common Rail Fuel System** — in the C175 engines are used on (793F, 795F AC, and 797F) trucks.

- **Oil Cooled Disc Brakes** — Provide retarding, service, parking, and secondary braking in a single sealed, fade-resistant, maintenance-free unit. Standard on the 770 through 775F and 777D, front brakes are caliper disc and can be switched out of the service system when not needed but activate as part of the secondary system. Standard on the 777F through 797F, front brakes are oil-cooled disc, providing excellent control in slippery conditions.
- **Automatic Retarder Control (ARC)** This option is standard on 770-797F — Electronically controls braking on grade to maintain optimal engine RPM and oil cooling. ARC benefits include engine over-speed protection, ease of operation, faster downhill speeds, smoother ride and better control in slippery conditions, and fuel efficiency.
- **Traction Control System (TCS) (option)** — Electronically monitors and controls rear wheel slippage for greater traction and enhanced truck performance in poor underfoot conditions. If slippage exceeds a set limit, the oil-cooled disc brakes engage to slow the spinning wheel. Torque is then automatically transferred to the wheel with better traction. Available on the 770 through 797F.
- **Full Hydraulic Steering** — Functions with front suspension cylinders serving as kingpins.
- **Suspension Cylinders** — Four independent, self-contained, nitrogen/oil-pneumatic suspension cylinders absorb loading and road shocks. Wide spacing for stability.
- **Truck Bodies** — A variety of truck bodies are available to meet your application specific requirements. Those options include MSDII (mine specific design), X, flat floor, dual slope and gateless coal bodies. The Caterpillar body program ensures the truck is configured for an optimal haulage solution.
- **Integral Roll Over Protective Structure (ROPS)** — Integral Four-Post ROPS cab standard on all models. Resiliently mounted to the main frame to reduce vibration and sound, the integral ROPS structure is designed as an extension of the truck frame. The ROPS/FOPS structure provides “five sided protection” for the operator and trainer.
- **Separate Hydraulic Systems** — Prevent cross contamination.

- **Safety** — Caterpillar continues to be proactive in developing construction and mining trucks that meet or exceed safety standards. Safety is an integral part of the machine design.

An example of enhanced safety through the development of products, processes and solutions includes Cat® Integrated Object Detection System™ which is an integrated camera and radar technology. More information on Object Detection is available in the technology section.

**NOTE:** Not all features are available on all models at this time. But consideration will be made to include on next generation trucks if applicable.

### Sustainability:

A variety of features improve sustainability in areas of decreasing waste, extending component life and lowering emissions levels. The 777F, 785D and 797F trucks offer Oil Renewal systems. The 785D, 793F, 797F trucks offer Continuous Rear Axle Filtration, Extended Life Filters and Extended maintenance intervals which aid in decreasing the amount of waste contributed to our environment.

- **Engines with advanced technology** contribute less emissions to the environment while maintaining fuel efficiency.
- **Advanced Surface Technology (AST)** is a replacement for hard chrome coatings on some steel parts, including Suspension and hoist Cylinder Rods.
- **Other features on 793F, 797F Mining trucks** include rear axle oil savers, front wheel sight glass, two piece cover on the final drive, ecology drains and brake wear indicators all of which help to maximize component life.

**NOTE:** Not all features are available on all models at this time. But consideration will be made to include on next generation trucks if applicable.

### Non-Dumper Offerings:

For certain applications the Caterpillar OEM Solution Group offers non-dumper arrangements for the 773F, 775F, 777F and 785D.

Non-dumper arrangements include a water truck and tractor configuration. For updates on additional offerings please contact Caterpillar OEM Solutions Group.

**NOTE:** Listed features may be standard on some models. Optional on others. Contact your Cat dealer for specific information.



MODEL	770		770		772	
Body Type	<b>Medium Impact Steel Flat Floor</b>		<b>Medium Impact Steel Dual Slope</b>		<b>Medium Impact Steel Flat Floor</b>	
Gross Machine Weight	71 214 kg	<b>157,000 lb</b>	71 214 kg	<b>157,000 lb</b>	82 100 kg	<b>181,000 lb</b>
Chassis Weight*	24 613 kg	<b>54,262 lb</b>	24 613 kg	<b>54,262 lb</b>	25 425 kg	<b>56,053 lb</b>
Body System Weight	10 029 kg	<b>22,110 lb</b>	10 019 kg	<b>22,088 lb</b>	10 439 kg	<b>23,013 lb</b>
Target Payload**	36 572 kg	<b>80,628 lb</b>	36 582 kg	<b>80,650 lb</b>	46 236 kg	<b>101,934 lb</b>
Capacity:						
Struck (SAE)	16.4 m <sup>3</sup>	<b>21.5 yd<sup>3</sup></b>	16.4 m <sup>3</sup>	<b>21.5 yd<sup>3</sup></b>	23.3 m <sup>3</sup>	<b>30.5 yd<sup>3</sup></b>
Heaped (2:1) (SAE)	25.1 m <sup>3</sup>	<b>32.8 yd<sup>3</sup></b>	25.1 m <sup>3</sup>	<b>32.8 yd<sup>3</sup></b>	31.3 m <sup>3</sup>	<b>41.0 yd<sup>3</sup></b>
Distribution Empty:						
Front		<b>48%</b>		<b>48%</b>		<b>48%</b>
Rear		<b>52%</b>		<b>52%</b>		<b>52%</b>
Distribution Loaded:						
Front		<b>33%</b>		<b>33%</b>		<b>33%</b>
Rear		<b>67%</b>		<b>67%</b>		<b>67%</b>
Engine Model	<b>C15 ACERT</b>		<b>C15 ACERT</b>		<b>C18 ACERT</b>	
Number of Cylinders	<b>6</b>		<b>6</b>		<b>6</b>	
Bore	137 mm	<b>5.4"</b>	137 mm	<b>5.4"</b>	145 mm	<b>5.7"</b>
Stroke	171 mm	<b>6.7"</b>	171 mm	<b>6.7"</b>	183 mm	<b>7.2"</b>
Displacement	15 L	<b>928 in<sup>3</sup></b>	15 L	<b>928 in<sup>3</sup></b>	18 L	<b>1105 in<sup>3</sup></b>
Net Power	355 kW	<b>476 hp</b>	355 kW	<b>476 hp</b>	399 kW	<b>535 hp</b>
Gross Power	381 kW	<b>511 hp</b>	381 kW	<b>511 hp</b>	446 kW	<b>598 hp</b>
Standard Tires	<b>18.00R33 (E4)</b>		<b>18.00R33 (E4)</b>		<b>21.00R33 (E4)</b>	
Machine Clearance Turning Circle	20.2 m	<b>66'3"</b>	20.2 m	<b>66'3"</b>	21.6 m	<b>70'10"</b>
Fuel Tank Refill Capacity	529 L	<b>140 U.S. gal</b>	529 L	<b>140 U.S. gal</b>	529 L	<b>140 U.S. gal</b>
Top Speed (Loaded)	74.8 km/h	<b>46.5 mph</b>	74.8 km/h	<b>46.5 mph</b>	79.7 km/h	<b>49.5 mph</b>
<b>GENERAL DIMENSIONS (Empty):</b>						
Height to Canopy Rock Guard Rail	4.14 m	<b>13'7"</b>	4.14 m	<b>13'7"</b>	4.22 m	<b>13'10"</b>
Wheelbase	3.96 m	<b>13'0"</b>	3.96 m	<b>13'0"</b>	3.96 m	<b>13'0"</b>
Overall Length (Operating)	8.74 m	<b>28'9"</b>	8.74 m	<b>28'9"</b>	8.74 m	<b>28'9"</b>
Overall Length (Shipping)	8.74 m	<b>28'9"</b>	8.74 m	<b>28'9"</b>	8.74 m	<b>28'9"</b>
Loading Height (Empty)	3.12 m	<b>10'3"</b>	3.12 m	<b>10'3"</b>	3.50 m	<b>11'6"</b>
Height at Full Dump	8.28 m	<b>27'2"</b>	8.28 m	<b>27'2"</b>	8.36 m	<b>27'5"</b>
Body Length (Target Length)	5.55 m	<b>18'3"</b>	5.55 m	<b>18'3"</b>	5.55 m	<b>18'3"</b>
Width (Operating)	4.75 m	<b>15'8"</b>	4.75 m	<b>15'8"</b>	4.75 m	<b>15'8"</b>
Width (Shipping)***	3.96 m	<b>13'0"</b>	3.96 m	<b>13'0"</b>	3.95 m	<b>13'0"</b>
Front Tire Tread	3.11 m	<b>10'3"</b>	3.11 m	<b>10'3"</b>	3.17 m	<b>10'5"</b>

\*Weights include lubricants, coolants and 100% fuel.

\*\*Refer to Caterpillar's 10/10/20 Payload Policy for Quarry & Construction Trucks.

\*\*\*Disassembled.



MODEL	772		773E****		773F	
Body Type	Medium Impact Steel Dual Slope		Medium Impact Steel Dual Slope		Medium Impact Steel Flat Floor	
Gross Machine Weight	82 100 kg	<b>181,000 lb</b>	99 300 kg	<b>219,000 lb</b>	100 698 kg	<b>222,000 lb</b>
Chassis Weight*	25 425 kg	<b>56,053 lb</b>	30 200 kg	<b>66,580 lb</b>	32 164 kg	<b>70,908 lb</b>
Body System Weight	10 413 kg	<b>22,956 lb</b>	9210 kg	<b>20,305 lb</b>	12 905 kg	<b>28,451 lb</b>
Target Payload**	46 262 kg	<b>101,991 lb</b>	55 460 kg	<b>122,268 lb</b>	55 629 kg	<b>122,641 lb</b>
Capacity:						
Struck (SAE)	24.2 m <sup>3</sup>	<b>31.7 yd<sup>3</sup></b>	26.6 m <sup>3</sup>	<b>34.8 yd<sup>3</sup></b>	25.9 m <sup>3</sup>	<b>33.8 yd<sup>3</sup></b>
Heaped (2:1) (SAE)	31.2 m <sup>3</sup>	<b>40.8 yd<sup>3</sup></b>	35.2 m <sup>3</sup>	<b>46 yd<sup>3</sup></b>	35.1 m <sup>3</sup>	<b>45.9 yd<sup>3</sup></b>
Distribution Empty:						
Front		<b>48%</b>		<b>47.3%</b>		<b>51%</b>
Rear		<b>52%</b>		<b>52.7%</b>		<b>49%</b>
Distribution Loaded:						
Front		<b>33%</b>		<b>33.3%</b>		<b>35%</b>
Rear		<b>67%</b>		<b>66.7%</b>		<b>65%</b>
Engine Model	<b>C18 ACERT</b>		<b>3412E</b>		<b>C27 ACERT</b>	
Number of Cylinders	<b>6</b>		<b>12</b>		<b>12</b>	
Bore	145 mm	<b>5.7"</b>	137 mm	<b>5.4"</b>	137 mm	<b>5.4"</b>
Stroke	183 mm	<b>7.2"</b>	152 mm	<b>6"</b>	152 mm	<b>6"</b>
Displacement	18 L	<b>1105 in<sup>3</sup></b>	27 L	<b>1649 in<sup>3</sup></b>	27 L	<b>1649 in<sup>3</sup></b>
Net Power	399 kW	<b>535 hp</b>	501 kW	<b>671 hp</b>	524 kW	<b>703 hp</b>
Gross Power	446 kW	<b>598 hp</b>	530 kW	<b>710 hp</b>	552 kW	<b>740 hp</b>
Standard Tires	<b>21.00R33 (E4)</b>		<b>24.00R35 (E4)</b>		<b>24.00R35 (E4)</b>	
Machine Clearance Turning Circle	21.6 m	<b>70'10"</b>	25 m	<b>82'0"</b>	26.1 m	<b>85'8"</b>
Fuel Tank Refill Capacity	529 L	<b>140 U.S. gal</b>	700 L	<b>185 U.S. gal</b>	700 L	<b>185 U.S. gal</b>
Top Speed (Loaded)	79.7 km/h	<b>49.5 mph</b>	62.2 km/h	<b>38.6 mph</b>	67.5 km/h	<b>41.9 mph</b>
<b>GENERAL DIMENSIONS (Empty):</b>						
Height to Canopy Rock Guard Rail	4.22 m	<b>13'10"</b>	4.39 m	<b>14'5"</b>	4.44 m	<b>14'7"</b>
Wheelbase	3.96 m	<b>13'0"</b>	4.19 m	<b>13'9"</b>	4.22 m	<b>13'10"</b>
Overall Length (Operating)	8.74 m	<b>28'9"</b>	9.60 m	<b>31'6"</b>	10.33 m	<b>33'11"</b>
Overall Length (Shipping)	8.74 m	<b>28'9"</b>	9.12 m	<b>29'11"</b>	9.20 m	<b>30'2"</b>
Loading Height (Empty)	3.50 m	<b>11'6"</b>	3.77 m	<b>12'4"</b>	3.77 m	<b>12'5"</b>
Height at Full Dump	8.36 m	<b>27'5"</b>	8.79 m	<b>28'10"</b>	9.26 m	<b>30'5"</b>
Body Length (Target Length)	5.55 m	<b>18'3"</b>	6.40 m	<b>21'0"</b>	6.34 m	<b>20'9"</b>
Width (Operating)	4.75 m	<b>15'8"</b>	5.07 m	<b>16'8"</b>	5.43 m	<b>17'10"</b>
Width (Shipping)***	3.95 m	<b>13'0"</b>	3.99 m	<b>13'1"</b>	3.99 m	<b>13'1"</b>
Front Tire Tread	3.17 m	<b>10'5"</b>	3.28 m	<b>10'9"</b>	3.21 m	<b>10'6"</b>

\*Weights include lubricants, coolants and 100% fuel.

\*\*Refer to Caterpillar's 10/10/20 Payload Policy for Quarry & Construction Trucks.

\*\*\*Disassembled.

\*\*\*\*India sourced, not available in all regions.



MODEL	773F		775F		775F	
Body Type	<b>Medium Impact Steel Dual Slope</b>		<b>Medium Impact Steel Flat Floor</b>		<b>Medium Impact Steel Dual Slope</b>	
Gross Machine Weight	100 698 kg	<b>222 000 lb</b>	109 769 kg	<b>242,000 lb</b>	109 769 kg	<b>242,000 lb</b>
Chassis Weight*	32 164 kg	<b>70,908 lb</b>	32 164 kg	<b>70,908 lb</b>	32 164 kg	<b>70,908 lb</b>
Body System Weight	12 961 kg	<b>28,574 lb</b>	13 456 kg	<b>29,665 lb</b>	13 552 kg	<b>29,877 lb</b>
Target Payload**	55 573 kg	<b>122,518 lb</b>	64 149 kg	<b>141,427 lb</b>	64 053 kg	<b>141,215 lb</b>
Capacity:						
Struck (SAE)	26.8 m <sup>3</sup>	<b>35.0 yd<sup>3</sup></b>	32.0 m <sup>3</sup>	<b>41.8 yd<sup>3</sup></b>	33.1 m <sup>3</sup>	<b>43.3 yd<sup>3</sup></b>
Heaped (2:1) (SAE)	35.6 m <sup>3</sup>	<b>46.5 yd<sup>3</sup></b>	41.9 m <sup>3</sup>	<b>54.8 yd<sup>3</sup></b>	42.5 m <sup>3</sup>	<b>55.6 yd<sup>3</sup></b>
Distribution Empty:						
Front		<b>51%</b>		<b>49%</b>		<b>49%</b>
Rear		<b>49%</b>		<b>51%</b>		<b>51%</b>
Distribution Loaded:						
Front		<b>35%</b>		<b>33%</b>		<b>33%</b>
Rear		<b>65%</b>		<b>67%</b>		<b>67%</b>
Engine Model	<b>C27 ACERT</b>		<b>C27 ACERT</b>		<b>C27 ACERT</b>	
Number of Cylinders	<b>12</b>		<b>12</b>		<b>12</b>	
Bore	137 mm	<b>5.4"</b>	137 mm	<b>5.4"</b>	137 mm	<b>5.4"</b>
Stroke	152 mm	<b>6"</b>	152 mm	<b>6"</b>	152 mm	<b>6"</b>
Displacement	27 L	<b>1649 in<sup>3</sup></b>	27 L	<b>1649 in<sup>3</sup></b>	27 L	<b>1649 in<sup>3</sup></b>
Net Power	524 kW	<b>703 hp</b>	552 kW	<b>740 hp</b>	552 kW	<b>740 hp</b>
Gross Power	552 kW	<b>740 hp</b>	587 kW	<b>787 hp</b>	587 kW	<b>787 hp</b>
Standard Tires	<b>24.00R35 (E4)</b>		<b>24.00R35 (E4)</b>		<b>24.00R35 (E4)</b>	
Machine Clearance Turning Circle	26.1 m	<b>85'8"</b>	26.1 m	<b>85'8"</b>	26.1 m	<b>85'8"</b>
Fuel Tank Refill Capacity	700 L	<b>185 U.S. gal</b>	700 L	<b>185 U.S. gal</b>	700 L	<b>185 U.S. gal</b>
Top Speed (Loaded)	67.5 km/h	<b>41.9 mph</b>	67.5 km/h	<b>41.9 mph</b>	67.5 km/h	<b>41.9 mph</b>
<b>GENERAL DIMENSIONS (Empty):</b>						
Height to Canopy Rock Guard Rail	4.46 m	<b>14'8"</b>	4.43 m	<b>14'6"</b>	4.43 m	<b>14'6"</b>
Wheelbase	4.22 m	<b>13'10"</b>	4.22 m	<b>13'10"</b>	4.22 m	<b>13'10"</b>
Overall Length (Operating)	10.25 m	<b>33'7"</b>	10.33 m	<b>33'11"</b>	10.33 m	<b>33'11"</b>
Overall Length (Shipping)	9.20 m	<b>30'2"</b>	9.21 m	<b>30'3"</b>	9.21 m	<b>30'3"</b>
Loading Height (Empty)	3.82 m	<b>12'6"</b>	3.97 m	<b>13'0"</b>	3.95 m	<b>12'11"</b>
Height at Full Dump	9.26 m	<b>30'5"</b>	9.26 m	<b>30'5"</b>	9.26 m	<b>30'5"</b>
Body Length (Target Length)	6.25 m	<b>20'6"</b>	6.20 m	<b>20'4"</b>	6.12 m	<b>20'1"</b>
Width (Operating)	5.43 m	<b>17'10"</b>	5.39 m	<b>17'8"</b>	5.26 m	<b>17'2"</b>
Width (Shipping)***	3.99 m	<b>13'1"</b>	3.97 m	<b>13'0"</b>	3.97 m	<b>13'0"</b>
Front Tire Tread	3.21 m	<b>10'6"</b>	3.21 m	<b>10'6"</b>	3.21 m	<b>10'6"</b>

\*Weights include lubricants, coolants and 100% fuel.

\*\*Refer to Caterpillar's 10/10/20 Payload Policy for Quarry & Construction Trucks.

\*\*\*Disassembled.





MODEL	777D†		777F	
	Dual Slope Lined		Dual Slope Lined	
Body Type				
Target Gross Machine Weight §	163 360 kg	<b>360,143 lb</b>	163 293 kg	<b>360,000 lb</b>
Basic Machine Weight*	33 951 kg	<b>74,849 lb</b>	33 438 kg	<b>73,718 lb</b>
Attachments**	17 377 kg	<b>38,310 lb</b>	17 114 kg	<b>37,730 lb</b>
Body Weight without Liners***	16 070 kg	<b>35,428 lb</b>	16 420 kg	<b>36,200 lb</b>
Full Liner	5432 kg	<b>11,975 lb</b>	5767 kg	<b>12,714 lb</b>
Operating Machine Weight	72 830 kg	<b>160,562 lb</b>	72 739 kg	<b>160,360 lb</b>
Debris (2% of Operating Machine Weight)	1457 kg	<b>3211 lb</b>	1455 kg	<b>3207 lb</b>
Empty Operating Weight	74 287 kg	<b>163,774 lb</b>	74 194 kg	<b>163,568 lb</b>
Target Payload §	90.9 m tons	<b>100 tons</b>	90.7 m tons	<b>100 tons</b>
Capacity:				
Heaped (2:1) (SAE) Base Body	60.1 m <sup>3</sup>	<b>78.6 yd<sup>3</sup></b>	60.2 m <sup>3</sup>	<b>78.8 yd<sup>3</sup></b>
Distribution Empty:				
Front		<b>47%</b>		<b>45%</b>
Rear		<b>53%</b>		<b>55%</b>
Distribution Loaded:				
Front		<b>33%</b>		<b>33%</b>
Rear		<b>67%</b>		<b>67%</b>
Engine Model	<b>3508B EU1</b>		<b>C32 ACERT</b>	
Number of Cylinders	<b>8</b>		<b>12</b>	
Bore	170 mm	<b>6.7"</b>	145 mm	<b>5.7"</b>
Stroke	190 mm	<b>7.5"</b>	162 mm	<b>6.4"</b>
Displacement	34.5 L	<b>2105 in<sup>3</sup></b>	32.1 L	<b>1959 in<sup>3</sup></b>
Net Power	699 kW	<b>938 hp</b>	700 kW	<b>938 hp</b>
Gross Power	746 kW	<b>1000 hp</b>	758 kW	<b>1016 hp</b>
Standard Tires	<b>27.00-R49 (E4)</b>		<b>27.00R49 (E4)</b>	
Machine Clearance Turning Circle	28.4 m	<b>93'2"</b>	28.4 m	<b>93'2"</b>
Fuel Tank Refill Capacity	1137 L	<b>300 U.S. gal</b>	1136 L	<b>300 U.S. gal</b>
Top Speed (Loaded)	60.4 km/h	<b>39.9 mph</b>	64.5 km/h	<b>40.1 mph</b>
<b>GENERAL DIMENSIONS (Empty):</b>				
Height to Canopy Rock Guard Rail	5.14 m	<b>16'10"</b>	5.17 m	<b>17'0"</b>
Wheelbase	4.57 m	<b>15'0"</b>	4.56 m	<b>15'0"</b>
Overall Length (Base Body)	9.78 m	<b>32'1"</b>	10.54 m	<b>34'7"</b>
Loading Height (Base Body)	4.38 m	<b>14'4"</b>	4.38 m	<b>14'4"</b>
Height at Full Dump	10.06 m	<b>33'0"</b>	10.33 m	<b>33'11"</b>
Body Length (Target Length)	7.23 m	<b>23'9"</b>	9.83 m	<b>32'3"</b>
Width (Operating)	6.11 m	<b>20'0"</b>	6.49 m	<b>21'4"</b>
Width (Shipping)***	3.51 m	<b>11'5"</b>	3.51 m	<b>11'5"</b>
Front Tire Tread	4.17 m	<b>13'8"</b>	4.17 m	<b>13'8"</b>

\*See Weight Definitions and Relations on 9-11. Note: No mandatory or optional attachments or fuel.

\*\*Typical selection of mandatory and optional attachments.

\*\*\*Data provided is for a representative body and liner package. Several dual slope, flat floor, and mine specific design (MSD) bodies and liner packages are available. All weights, capacities, and dimensions are dependent on the machine configuration (body type, attachments, tires, and optional equipment selected).

§ Reference Caterpillar's latest 10/10/20 Payload Policy for information on gross machine operating weight and target payload.

† India sourced, only available in Asia Pacific.



MODEL	785C		785D		789C	
Body Type	Dual Slope		Dual Slope		Dual Slope	
Target Gross Machine Weight §	249 476 kg	<b>550,000 lb</b>	249 476 kg	<b>550,000 lb</b>	317 515 kg	<b>700,000 lb</b>
Basic Machine Weight*	59 669 kg	<b>131,548 lb</b>	53 265 kg	<b>117,429 lb</b>	67 344 kg	<b>148,425 lb</b>
Attachments**	23 267 kg	<b>51,295 lb</b>	30 786 kg	<b>67,871 lb</b>	30 668 kg	<b>67,592 lb</b>
Body Weight without Liners***	22 153 kg	<b>48,839 lb</b>	22 293 kg	<b>49,148 lb</b>	27 094 kg	<b>59,715 lb</b>
Full Liner	7739 kg	<b>17,062 lb</b>	7876 kg	<b>17,364 lb</b>	9392 kg	<b>20,701 lb</b>
Standard Sideboard	1263 kg	<b>2785 lb</b>	1263 kg	<b>2785 lb</b>	1292 kg	<b>2848 lb</b>
Operating Machine Weight	112 828 kg	<b>248,744 lb</b>	114 220 kg	<b>251,812 lb</b>	135 790 kg	<b>299,281 lb</b>
Debris (2% of Operating Machine Weight)	2257 kg	<b>4975 lb</b>	2284 kg	<b>5035 lb</b>	1905 kg	<b>4198 lb</b>
Empty Operating Weight	115 085 kg	<b>253,718 lb</b>	116 505 kg	<b>256,849 lb</b>	137 695 kg	<b>303,479 lb</b>
Target Payload §	134 m tons	<b>148 tons</b>	133 m tons	<b>147 tons</b>	177 m tons	<b>195 tons</b>
Capacity:						
Heaped (2:1) (SAE) Base Body	78 m <sup>3</sup>	<b>102 yd<sup>3</sup></b>	78 m <sup>3</sup>	<b>102 yd<sup>3</sup></b>	105 m <sup>3</sup>	<b>137 yd<sup>3</sup></b>
Heaped (2:1) (SAE) with Std. Sideboards	91 m <sup>3</sup>	<b>119 yd<sup>3</sup></b>	91 m <sup>3</sup>	<b>119 yd<sup>3</sup></b>	120 m <sup>3</sup>	<b>157 yd<sup>3</sup></b>
Distribution Empty:						
Front		<b>43.5%</b>		<b>46%</b>		<b>46.9%</b>
Rear		<b>56.5%</b>		<b>54%</b>		<b>53.1%</b>
Distribution Loaded:						
Front		<b>33%</b>		<b>33%</b>		<b>33.6%</b>
Rear		<b>67%</b>		<b>67%</b>		<b>66.4%</b>
Engine Model	<b>3512B EUI</b>		<b>3512C HD-EUI</b>		<b>3516B EUI</b>	
Number of Cylinders	<b>12</b>		<b>12</b>		<b>16</b>	
Bore	170 mm	<b>6.7"</b>	170 mm	<b>6.7"</b>	170 mm	<b>6.7"</b>
Stroke	190 mm	<b>7.5"</b>	215 mm	<b>8.46"</b>	190 mm	<b>7.5"</b>
Displacement	51.8 L	<b>3158 in<sup>3</sup></b>	58.56 L	<b>3574 in<sup>3</sup></b>	69 L	<b>4210 in<sup>3</sup></b>
Net Power	1005 kW	<b>1348 hp</b>	1005 kW	<b>1348 hp</b>	1320 kW	<b>1771 hp</b>
Gross Power	1082 kW	<b>1450 hp</b>	1082 kW	<b>1450 hp</b>	1417 kW	<b>1900 hp</b>
Standard Tires	<b>33.00R51</b>		<b>33.00R51</b>		<b>37.00R57</b>	
Machine Clearance Turning Circle	30.6 m	<b>100'5"</b>	33.2 m	<b>108'11"</b>	30.2 m	<b>99'2"</b>
Fuel Tank Refill Capacity	1893 L	<b>500 U.S. gal</b>	1893 L	<b>500 U.S. gal</b>	3222 L	<b>850 U.S. gal</b>
Top Speed (Loaded)	56.5 km/h	<b>35.1 mph</b>	56.5 km/h	<b>35.1 mph</b>	57.2 km/h	<b>35.5 mph</b>
<b>GENERAL DIMENSIONS (Empty):</b>						
Height to Canopy Rock Guard Rail	5.77 m	<b>18'11"</b>	5.68 m	<b>18'7"</b>	6.15 m	<b>20'2"</b>
Wheelbase	5.18 m	<b>17'0"</b>	5.18 m	<b>17'0"</b>	5.70 m	<b>18'8"</b>
Overall Length (Base Body)	10.62 m	<b>34'10"</b>	11.55 m	<b>37'9"</b>	12.18 m	<b>39'11"</b>
Loading Height (Base Body)	4.97 m	<b>16'4"</b>	4.97 m	<b>16'4"</b>	5.21 m	<b>17'1"</b>
Height at Full Dump	11.21 m	<b>36'9"</b>	11.81 m	<b>38'9"</b>	11.90 m	<b>39'1"</b>
Body Length (Target Length)	7.65 m	<b>25'1"</b>	7.65 m	<b>25'2"</b>	8.15 m	<b>26'9"</b>
Width (Operating)	6.64 m	<b>21'4"</b>	7.06 m	<b>23'2"</b>	7.67 m	<b>25'2"</b>
Width (Shipping)***	3.91 m	<b>12'10"</b>	3.91 m	<b>12'10"</b>	3.84 m	<b>12'7"</b>
Front Tire Tread	4.85 m	<b>15'11"</b>	4.85 m	<b>15'11"</b>	5.43 m	<b>17'10"</b>

\*See Weight Definitions and Relations on 9-11. Note: No mandatory or optional attachments or fuel.

\*\*Typical selection of mandatory and optional attachments.

\*\*\*Data provided is for a representative body and liner package. Several dual slope, flat floor, and mine specific design (MSD) bodies and liner packages are available. All weights, capacities, and dimensions are dependent on the machine configuration (body type, attachments, tires, and optional equipment selected).

§ Reference Caterpillar's latest 10/10/20 Payload Policy for information on gross machine operating weight and target payload.



**793D  
Standard  
(MA1)**

**793D  
Additional  
Retarding (MA2)**

**793D  
Extra Top  
Speed (MA3)**

MODEL	MSD II		MSD II		MSD II	
Body Type	MSD II		MSD II		MSD II	
Target Gross Machine Weight §	383 673 kg	<b>846,000 lb</b>	383 673 kg	<b>846,000 lb</b>	383 673 kg	<b>846,000 lb</b>
Basic Machine Weight*	51 932 kg	<b>114,513 lb</b>	52 107 kg	<b>114,843 lb</b>	47 881 kg	<b>105,530 lb</b>
Attachments**	45 292 kg	<b>99,861 lb</b>	46 669 kg	<b>102,898 lb</b>	50 752 kg	<b>111,900 lb</b>
Body Weight without Liners***	26 960 kg	<b>59,437 lb</b>	26 960 kg	<b>59,437 lb</b>	26 960 kg	<b>59,437 lb</b>
Operating Machine Weight	154 059 kg	<b>339,667 lb</b>	155 611 kg	<b>343,090 lb</b>	155 468 kg	<b>342,775 lb</b>
Debris (2% of Operating Machine Weight)	3081 kg	<b>6793 lb</b>	3112 kg	<b>6862 lb</b>	3109 kg	<b>6855 lb</b>
Empty Operating Weight	157 140 kg	<b>346,460 lb</b>	158 723 kg	<b>349,951 lb</b>	158 577 kg	<b>349,630 lb</b>
Target Payload §	227 m tons	<b>250 tons</b>	225 m tons	<b>248 tons</b>	226 m tons	<b>249 tons</b>
Capacity:						
Heaped (2:1) (SAE) Base Body	176 m³	<b>230 yd³</b>	176 m³	<b>230 yd³</b>	176 m³	<b>230 yd³</b>
Distribution Empty:						
Front	<b>47%</b>		<b>47%</b>		<b>47%</b>	
Rear	<b>53%</b>		<b>53%</b>		<b>53%</b>	
Distribution Loaded:						
Front	<b>33%</b>		<b>33%</b>		<b>33%</b>	
Rear	<b>67%</b>		<b>67%</b>		<b>67%</b>	
Engine Model	<b>3516B HD EUI</b>		<b>3516B HD EUI</b>		<b>3516B HD EUI</b>	
Number of Cylinders	<b>16</b>		<b>16</b>		<b>16</b>	
Bore	170 mm	<b>6.7"</b>	170 mm	<b>6.7"</b>	170 mm	<b>6.7"</b>
Stroke	215 mm	<b>8.5"</b>	215 mm	<b>8.5"</b>	215 mm	<b>8.5"</b>
Displacement	78 L	<b>4760 in³</b>	78 L	<b>4760 in³</b>	78 L	<b>4760 in³</b>
Net Power	1743 kW	<b>2337 hp</b>	1743 kW	<b>2337 hp</b>	1743 kW	<b>2337 hp</b>
Gross Power	1801 kW	<b>2415 hp</b>	1801 kW	<b>2415 hp</b>	1801 kW	<b>2415 hp</b>
Standard Tires	<b>40/00R57</b>		<b>40/00R57</b>		<b>40/00R57</b>	
Machine Clearance Turning Circle	33 m	<b>107'0"</b>	33 m	<b>107'0"</b>	33 m	<b>107'0"</b>
Fuel Tank Refill Capacity	4353 L	<b>1150 U.S. gal</b>	4353 L	<b>1150 U.S. gal</b>	4353 L	<b>1150 U.S. gal</b>
Top Speed (Loaded)	59.9 km/h	<b>37.2 mph</b>	59.9 km/h	<b>37.2 mph</b>	59.9 km/h	<b>37.2 mph</b>
<b>GENERAL DIMENSIONS (Empty):</b>						
Height to Canopy Rock Guard Rail	6.6 m	<b>21'8"</b>	6.6 m	<b>21'8"</b>	6.6 m	<b>21'8"</b>
Wheelbase	5.91 m	<b>19'5"</b>	5.91 m	<b>19'5"</b>	5.91 m	<b>19'5"</b>
Overall Length (Base Body)	13.01 m	<b>42'9"</b>	13.01 m	<b>42'9"</b>	13.01 m	<b>42'9"</b>
Loading Height (Base Body)	6.5 m	<b>21'5"</b>	6.5 m	<b>21'5"</b>	6.5 m	<b>21'5"</b>
Height at Full Dump	13.25 m	<b>43'6"</b>	13.25 m	<b>43'6"</b>	13.25 m	<b>43'6"</b>
Body Length (Target Length)	8.99 m	<b>29'6"</b>	8.99 m	<b>29'6"</b>	8.99 m	<b>29'6"</b>
Width (Operating)	8.3 m	<b>27'3"</b>	8.3 m	<b>27'3"</b>	8.3 m	<b>27'3"</b>
Width (Shipping)***	4.1 m	<b>13'5"</b>	4.1 m	<b>13'5"</b>	4.1 m	<b>13'5"</b>
Front Tire Tread	5.63 m	<b>18'6"</b>	5.63 m	<b>18'6"</b>	5.63 m	<b>18'6"</b>

\*See Weight Definitions and Relations on 9-11. Note: No mandatory or optional attachments or fuel.

\*\*Typical selection of mandatory and optional attachments.

\*\*\*Data provided for the 793D Standard (MA1) is for a representative body and liner package. Several dual slope, flat floor, and mine specific design (MSD) bodies and liner packages are available. All weights, capacities, and dimensions are dependent on the machine configuration (body type, attachments, tires, and optional equipment selected).

§ Reference Caterpillar's latest 10/10/20 Payload Policy for information on gross machine operating weight and target payload.



**793D  
Extra Life  
Wheel Stations (MA4)**

**793D  
High Altitude (MA5)**

<b>MODEL</b>	<b>MSD II</b>		<b>MSD II</b>	
Body Type				
Target Gross Machine Weight §	383 673 kg	<b>846,00 lb</b>	383 673 kg	<b>846,000 lb</b>
Basic Machine Weight*	52 107 kg	<b>115,381 lb</b>	52 352 kg	<b>115,437 lb</b>
Attachments**	46 623 kg	<b>102,895 lb</b>	69 906 kg	<b>154,113 lb</b>
Body Weight without Liners***	26 960 kg	<b>59,437 lb</b>	32 650 kg	<b>71,961 lb</b>
Operating Machine Weight	160 675 kg	<b>354,254 lb</b>	154 908 kg	<b>341,511 lb</b>
Debris (2% of Operating Machine Weight)	3213 kg	<b>7085 lb</b>	2370 kg	<b>5224 lb</b>
Empty Operating Weight	163 888 kg	<b>361,339 lb</b>	157 278 kg	<b>346,735 lb</b>
Target Payload §	220 m tons	<b>242 tons</b>	226 m tons	<b>250 tons</b>
Capacity:				
Heaped (2:1) (SAE) Base Body	176 m <sup>3</sup>	<b>230 yd<sup>3</sup></b>	140 m <sup>3</sup>	<b>195 yd<sup>3</sup></b>
Distribution Empty:				
Front		<b>47%</b>		<b>46.9%</b>
Rear		<b>53%</b>		<b>53.1%</b>
Distribution Loaded:				
Front		<b>33%</b>		<b>33.3%</b>
Rear		<b>67%</b>		<b>66.7%</b>
Engine Model	<b>3516B HD EUI</b>		<b>3516B EUI</b>	
Number of Cylinders	<b>16</b>		<b>16</b>	
Bore	170 mm	<b>6.7"</b>	170 mm	<b>6.7"</b>
Stroke	215 mm	<b>8.5"</b>	190 mm	<b>7.5"</b>
Displacement	78 L	<b>4760 in<sup>2</sup></b>	69 L	<b>4210 in<sup>3</sup></b>
Net Power	1743 kW	<b>2337 hp</b>	1615 kW	<b>2166 hp</b>
Gross Power	1801 kW	<b>2415 hp</b>	1715 kW	<b>2300 hp</b>
Standard Tires	<b>40/00R57</b>		<b>40/00R57</b>	
Machine Clearance Turning Circle	33 m	<b>107'0"</b>	32.7 m	<b>107'3"</b>
Fuel Tank Refill Capacity	4353 L	<b>1150 U.S. gal</b>	4353 L	<b>1150 U.S. gal</b>
Top Speed (Loaded)	59.9 km/h	<b>37.2 mph</b>	59.9 km/h	<b>37.2 mph</b>
<b>GENERAL DIMENSIONS (Empty):</b>				
Height to Canopy Rock Guard Rail	6.6 m	<b>21'8"</b>	6.59 m	<b>21'8"</b>
Wheelbase	5.91 m	<b>19'5"</b>	5.91 m	<b>19'5"</b>
Overall Length (Base Body)	13.01 m	<b>42'9"</b>	13.01 m	<b>42'9"</b>
Loading Height (Base Body)	6.5 m	<b>21'5"</b>	5.87 m	<b>19'4"</b>
Height at Full Dump	13.25 m	<b>43'6"</b>	13.25 m	<b>43'6"</b>
Body Length (Target Length)	8.99 m	<b>29'6"</b>	8.99 m	<b>29'6"</b>
Width (Operating)	8.3 m	<b>27'3"</b>	8.28 m	<b>27'2"</b>
Width (Shipping)	4.1 m	<b>13'5"</b>	4.09 m	<b>13'5"</b>
Front Tire Tread	5.63 m	<b>18'6"</b>	5.61 m	<b>18'5"</b>

\*See Weight Definitions and Relations on 9-11. Note: No mandatory or optional attachments or fuel.

\*\*Typical selection of mandatory and optional attachments.

\*\*\*Data provided is for a representative body and liner package. Several dual slope, flat floor, and mine specific design (MSD) bodies and liner packages are available. All weights, capacities, and dimensions are dependent on the machine configuration (body type, attachments, tires, and optional equipment selected).

§ Reference Caterpillar's latest 10/10/20 Payload Policy for information on gross machine operating weight and target payload.



793F

Extra Life  
Wheel Stations

797F

MODEL	793F Standard		793F Extra Life Wheel Stations		797F	
	MSD II		MSD II		MSD II	
Body Type						
Target Gross Machine Weight §	386 007 kg	<b>851,000 lb</b>	390 089 kg	<b>860,000 lb</b>	623 690 kg	<b>1,375,000 lb</b>
Basic Machine Weight*	42 638 kg	<b>94,000 lb</b>	42 638 kg	<b>94,000 lb</b>	129 550 kg	<b>285,609 lb</b>
Attachments**	55 349 kg	<b>122,024 lb</b>	57 856 kg	<b>127,551 lb</b>	78 591 kg	<b>173,264 lb</b>
Body Weight without Liners***	26 960 kg	<b>59,437 lb</b>	26 960 kg	<b>59,437 lb</b>	43 820 kg	<b>96,607 lb</b>
Full Liner†	—	—	—	—	3298 kg	<b>7271 lb</b>
Operating Machine Weight	157 234 kg	<b>346,642 lb</b>	159 741 kg	<b>352,169 lb</b>	258 357 kg	<b>569,580 lb</b>
Debris (2% of Operating Machine Weight)	3145 kg	<b>6933 lb</b>	3195 kg	<b>7043 lb</b>	5167 kg	<b>11,391 lb</b>
Empty Operating Weight	160 379 kg	<b>353,575 lb</b>	162 936 kg	<b>359,212 lb</b>	263 524 kg	<b>580,971 lb</b>
Target Payload §	226 m tons	<b>249 tons</b>	228 m tons	<b>250 tons</b>	345-363 m tons	<b>380-400 tons</b>
Capacity:						
Heaped (2:1) (SAE) Base Body	176 m³	<b>230 yd³</b>	176 m³	<b>230 yd³</b>	240-267 m³	<b>315-350 yd³</b>
Distribution Empty:						
Front		<b>48%</b>		<b>48%</b>		<b>43.5%</b>
Rear		<b>52%</b>		<b>52%</b>		<b>56.5%</b>
Distribution Loaded:						
Front		<b>33%</b>		<b>33%</b>		<b>33.3%</b>
Rear		<b>67%</b>		<b>67%</b>		<b>66.7%</b>
Engine Model	<b>C175-16</b>		<b>C175-16</b>		<b>C175-20</b>	
Number of Cylinders	<b>16</b>		<b>16</b>		<b>20</b>	
Bore	175 mm	<b>6.9"</b>	175 mm	<b>6.9"</b>	175 mm	<b>6.9"</b>
Stroke	220 mm	<b>8.7"</b>	220 mm	<b>8.7"</b>	220 mm	<b>8.7"</b>
Displacement	85 L	<b>5187 in³</b>	85 L	<b>5187 in³</b>	106 L	<b>6469 in³</b>
Net Power	1848 kW	<b>2478 hp</b>	1848 kW	<b>2478 hp</b>	2830 kW	<b>3795 hp</b>
Gross Power	1976 kW	<b>2650 hp</b>	1976 kW	<b>2650 hp</b>	2983 kW	<b>4000 hp</b>
Standard Tires	<b>46/90R57</b>		<b>46/90R57</b>		<b>59/80R63</b>	
Machine Clearance Turning Circle	33 m	<b>107'0"</b>	33 m	<b>107'0"</b>	42.1 m	<b>138'1"</b>
Fuel Tank Refill Capacity	2839 L	<b>750 U.S. gal</b>	2839 L	<b>750 U.S. gal</b>	7571 L	<b>2000 U.S. gal</b>
Top Speed (Loaded)	60.4 km/h	<b>37.6 mph</b>	60.4 km/h	<b>37.6 mph</b>	67.9 km/h	<b>42.2 mph</b>
<b>GENERAL DIMENSIONS (Empty):</b>						
Height to Canopy Rock Guard Rail	6.6 m	<b>21'8"</b>	6.6 m	<b>21'8"</b>	7.71 m	<b>25'4"</b>
Wheelbase	5.91 m	<b>19'5"</b>	5.91 m	<b>19'5"</b>	7.2 m	<b>23'7"</b>
Overall Length (Base Body)	13.7 m	<b>44'11"</b>	13.7 m	<b>44'11"</b>	14.87 m	<b>48'9"</b>
Loading Height (Base Body)	6.5 m	<b>21'5"</b>	6.5 m	<b>21'5"</b>	7.0 m	<b>23'0"</b>
Height at Full Dump	13.9 m	<b>45'6"</b>	13.9 m	<b>45'6"</b>	15.7 m	<b>51'6"</b>
Body Length (Target Length)	8.99 m	<b>29'6"</b>	8.99 m	<b>29'6"</b>	9.9 m	<b>32'6"</b>
Width (Operating)	8.3 m	<b>27'3"</b>	8.3 m	<b>27'3"</b>	9.75 m	<b>32'0"</b>
Width (Shipping)	4.1 m	<b>13'5"</b>	4.1 m	<b>13'5"</b>	9.7 m	<b>31'10"</b>
Front Tire Tread	5.63 m	<b>18'6"</b>	5.63 m	<b>18'6"</b>	6.23 m	<b>20'5"</b>

\*See Weight Definitions and Relations on 9-11. Note: No mandatory or optional attachments or fuel.

\*\*Typical selection of mandatory and optional attachments.

\*\*\*Data provided is for a representative body and liner package. Several dual slope, flat floor, and mine specific design (MSD) bodies and liner packages are available. All weights, capacities, and dimensions are dependent on the machine configuration (body type, attachments, tires, and optional equipment selected).

§ Reference Caterpillar's latest 10/10/20 Payload Policy for information on gross machine operating weight and target payload.

† Liner used for 797F is a ½ solid liner.

**CAT LARGE TRUCK WEIGHT DEFINITIONS**

Target Gross Machine Weight	<ul style="list-style-type: none"> <li>– Loaded operating machine weight</li> <li>– Optimum productivity and cost per ton</li> <li>– Used for performance curves and calculations</li> </ul>
Basic Machine Weight	Basic chassis weight including shipping fluids, but no attachments, options, body, or tires
Attachments	Combined weight of mandatory attachments and a minimal representation of optional attachments
Body Weight without Liners	Representative weight of body called out in Body Type
Full Liner	Weight of solid steel full liner package for selected Body Type
Standard Sideboard	Weight of appropriate sideboard for selected Body Type and Model
Operating Machine Weight	Basic machine weight plus full fuel, tires, rims, selected attachments, operator, and body
Debris	2%–8% of operating machine weight depending on application
Empty Operating Weight	Operating machine weight plus debris
Target Payload	Target gross machine weight minus empty operating weight

**CAT LARGE TRUCK WEIGHT RELATIONS\***

Operating Machine Weight	Operating Machine Weight = Basic Machine Weight + Attachments + Body Weight without Liners + Full Liner + Standard Sideboard
Empty Operating Weight	Empty Operating Weight = Operating Machine Weight + Debris
Target Payload	Target Payload = Target Gross Machine Weight — Empty Operating Weight
Target Gross Machine Weight	TGMW
Basic Machine Weight	BMW
Operating Machine Weight	OMW
Empty Operating Weight	EOW
Target Payload	TP

\*Reference Caterpillar's latest 10/10/20 Payload Policy.

MODEL TIRE SIZE	PLY RATING/ STAR RATING*	TYPE	MODEL TIRE SIZE	PLY RATING/ STAR RATING*	TYPE
<b>770</b>			<b>789C</b>		
18.00R33	★★	E-3	37.00R57	★★	E-4
18.00R33◀	★★	E-4	<b>793D</b>		
21/90R33	★★	E-4	40.00-57	68	E-4
<b>772</b>			45R57	★★	E-4
21.00R33◀	★★	E-4	46/90R57	★★	E-4
<b>773E</b>			<b>793F</b>		
24.00-35	42	E-4	40.00-57	68	E-4
24.00R35	★★	E-3	45R57	★★	E-4
<b>773F</b>			46/90R57	★★	E-4
24.00-35	36	E-4	50/80R57	★★	E-4
24.00-35	42	E-4	<b>797F</b>		
24.00R35	★★	E-3	59/80R63	★★	E-4
24.00R35◀	★★	E-4			
<b>775F</b>					
24.00R35◀	★★	E-4			
24.00R35	★★	E-3			
<b>777D, 777F</b>					
27.00R49	★★	E-3			
27.00R49◀	★★	E-4			
27.00-49	48	E-4			
<b>785C, 785D</b>					
33.00R51	★★	E-3			
33.00R51	★★	E-4			

\*Manufacturer uses star (★) rating system instead of ply rating.  
 ◀No charge tire.

**USE OF BRAKE PERFORMANCE CURVES**

The speed that can be maintained when the machine is descending a grade with retarder applied can be determined from the retarder curves in this section when gross machine weight and total effective grade are known.

Select appropriate grade distance chart that covers total downhill haul; don't break haul into individual segments.

To determine brake performance: Read from gross weight down to the percent effective grade. (Effective grade equals actual % grade *minus* 1% for each 10 kg/metric ton (20 lb./U.S. ton) of rolling resistance.) From this weight-effective grade point, read horizontally to the curve with the highest obtainable speed range, then down to maximum descent speed brakes can safely handle without exceeding cooling capacity. When braking, engine RPM should be maintained at the highest possible level without overspeeding. If cooling oil overheats, reduce ground speed to allow transmission to shift to next lower speed range.

**USE OF RIMPULL-SPEED-GRADEABILITY CURVES**

(See Wheel Tractor Scraper Section)

**Total Effective Grade** (or Total Resistance) is grade assistance *minus* rolling resistance.

10 kg/metric ton (20 lb./U.S. ton) = 1% adverse grade.

*Example —*

With a favorable grade of 20% and rolling resistance of 50 kg/metric ton (100 lb./U.S. ton), find Total Effective Grade.

$$(50 \text{ kg/metric ton}) \div 10 = 5\% \text{ Effective Grade (from Rolling Resistance)}$$

$$100 \text{ lb/ton} \div 20 = 5\% \text{ Effective Grade}$$

$$20\% \text{ (grade)} - 5\% \text{ (resistance)} = 15\% \text{ Total Effective Grade}$$

**TYPICAL FIXED TIMES FOR HAULING UNITS**

Wait time, delays and operator efficiency all impact cycle time. Minimizing truck exchange time can have a significant effect on productivity.

Fixed time for hauling units include:

1. Truck load time (various with loading tool)
2. Truck maneuver in load area (Truck exchange) (Typically 0.6-0.8 min.)
3. Maneuver and dump time at dump point (Typically 1.0-1.2 min.)

Total cycle time is the combination of:

1. The above fixed time
2. Hauling time (Loaded)
3. Return time (Empty)

*Example — assume load tool spots hauler with full bucket*

	<b>988F</b>	<b>5130B</b>
cycle times	.60	.45
First pass (dump time)	.10 min.	.05 min.
2 passes (full cycle)	.70	.50
3 passes "	1.30	.95
4 passes "	1.90	1.40
5 passes "	2.50	1.85
6 passes "	3.10	2.30
7 passes "	3.70	2.75
8 passes "	4.30	3.20
9 passes "	4.90	3.65
10 passes "	5.40	4.10

**NOTE:** Other sizes of loading tools will have different cycle times. See Wheel Loader section for **average** cycle times for truck loading.



**MECHANICAL POWER TRAIN EFFICIENCIES**

In selling against electric drive trucks, power train efficiency is an important consideration. To better illustrate the advantages of mechanical drive performance, grade horsepower, power train efficiency, and retarding horsepower should be compared to electric drive trucks.

Grade horsepower can be calculated by the following formula:

$$\begin{array}{l} \text{Metric} \\ \text{grade HP} = \frac{\text{GMW (kg)} \times \text{TR} \times \text{Speed (km/h)}}{273.75} \end{array}$$

$$\begin{array}{l} \text{English} \\ = \frac{\text{GMW (lb)} \times \text{TR} \times \text{Speed (mph)}}{375} \end{array}$$

where TR  
(total  
resistance) = Rolling resistance + Grade resistance  
(expressed as a decimal)

$$\begin{array}{l} \text{English example} \\ 700,000 \text{ lb GMW, 2\% rolling resistance, +8\% actual} \\ \text{grade at 8.2 mph would require 1530 HP} \\ \frac{700,000 \times (.02 + .08) \times 8.2}{375} = 1530 \text{ HP} \end{array}$$

$$\begin{array}{l} \text{Metric example} \\ 317\,520 \text{ kg GMW, 2\% rolling resistance, +8\% actual} \\ \text{grade at 13.2 km/h would require 1530 HP} \\ \frac{317\,520 \times (.02 + .08) \times 13.2}{273.75} = 1530 \text{ HP} \end{array}$$

We then calculate power train efficiency by dividing grade horsepower by the gross horsepower produced by the engine. Most electric drive trucks run at constant maximum horsepower while under load. Mechanical drive trucks, however, lug the engine and may produce somewhat less than maximum horsepower. Engine power curves must be utilized to determine exact horsepower produced.

$$\begin{array}{l} \text{Example} \\ \frac{1530 \text{ grade horsepower}}{1800 \text{ gross engine HP}} \times 100 = 85\% \text{ power train} \\ \text{efficiency} \end{array}$$

This exercise illustrates the effect of an efficient mechanical drive power train and should yield results in the 80-85% efficiency range. The same calculation for electric drive trucks would be lower (70-78% range) with a maximum efficiency of about 78% for the most common systems.

Likewise, retarding horsepower being consumed by the retarding system can be calculated by the following formula:

$$\begin{array}{l} \text{Metric} \\ \text{retarding} \\ \text{HP} = \frac{\text{GMW (kg)} \times \text{TR} \times \text{Speed (km/h)}}{273.75} \end{array}$$

$$\begin{array}{l} \text{English} \\ = \frac{\text{GMW (lb)} \times \text{TR} \times \text{Speed (mph)}}{375} \end{array}$$

where TR  
(total  
resistance) = Rolling resistance + Grade resistance  
(expressed as a decimal)

$$\begin{array}{l} \text{English example} \\ 700,000 \text{ lb GMW, 2\% rolling resistance, -8\% actual} \\ \text{grade at 14.7 mph would equate to -1646 HP} \\ \frac{700,000 \times (.02 - .08) \times 14.7}{375} = 1646 \text{ HP} \end{array}$$

$$\begin{array}{l} \text{Metric example} \\ 317\,520 \text{ kg GMW, 2\% rolling resistance, -8\% actual} \\ \text{grade at 23.6 km/h would equate to -1646 HP} \\ \frac{317\,520 \times (.02 - .08) \times 23.6}{273.75} = 1646 \text{ HP} \end{array}$$

This formula is intended for use in determining horsepower being consumed in the field based on field measurements. It is not intended to indicate how fast trucks should be operated on grade. Only job conditions, proper operating procedure, and good judgement should determine safe operating speeds during retarder use.

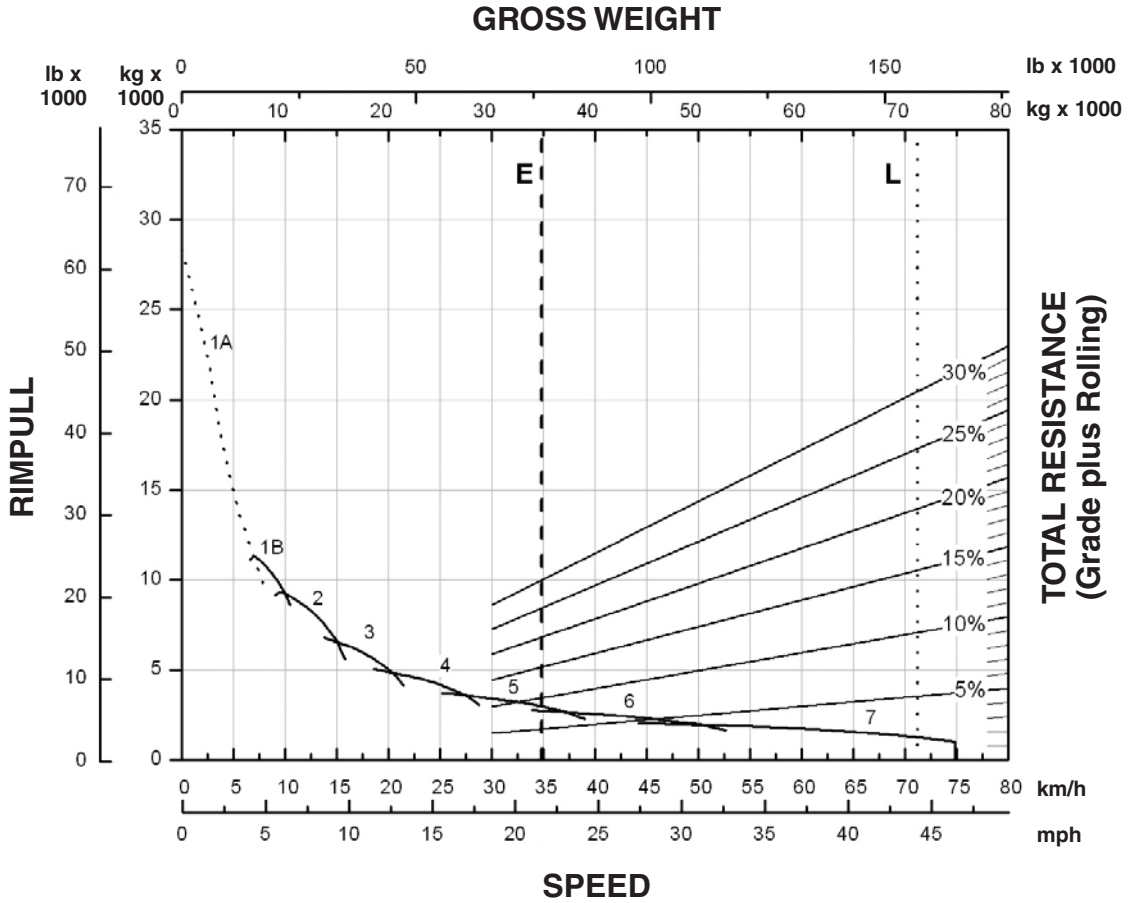

**KEY**

- 1A — 1st Gear (Torque Converter)
- 1B — 1st Gear
- 2 — 2nd Gear
- 3 — 3rd Gear
- 4 — 4th Gear
- 5 — 5th Gear
- 6 — 6th Gear
- 7 — 7th Gear

**KEY**

- E — Empty 34 642 kg (76,372 lb)
- L — Target GMW 71 214 kg (157,000 lb)

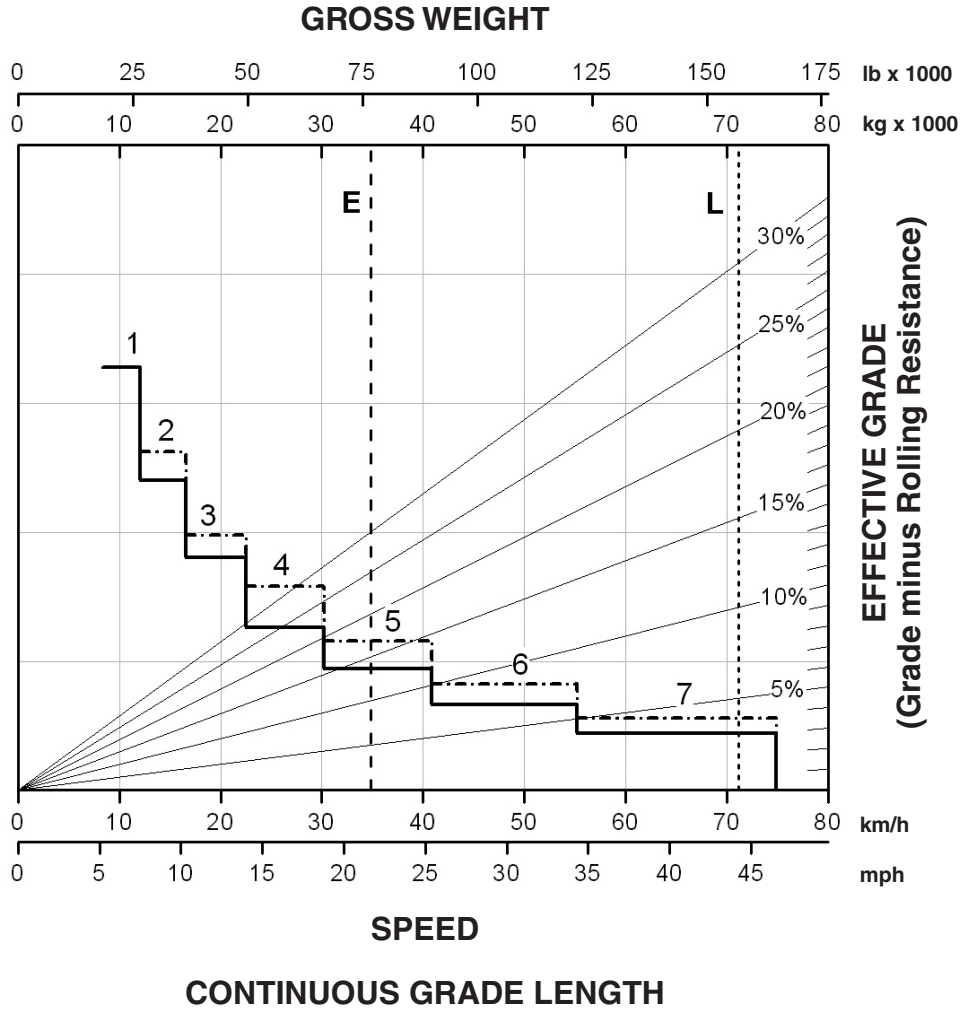

- KEY**
- 1 — 1st Gear
  - 2 — 2nd Gear
  - 3 — 3rd Gear
  - 4 — 4th Gear
  - 5 — 5th Gear
  - 6 — 6th Gear
  - 7 — 7th Gear

- KEY**
- E — Empty 34 642 kg (76,372 lb)
  - L — Target GMW 71 214 kg (157,000 lb)
  - With ARC Only
  - - - - - ARC and Engine Brake

770 Brake Performance

- 450 m (1500 ft)
- 600 m (2000 ft)
- 900 m (3000 ft)
- 1500 m (5000 ft)

Construction & Mining Trucks

GROSS WEIGHT

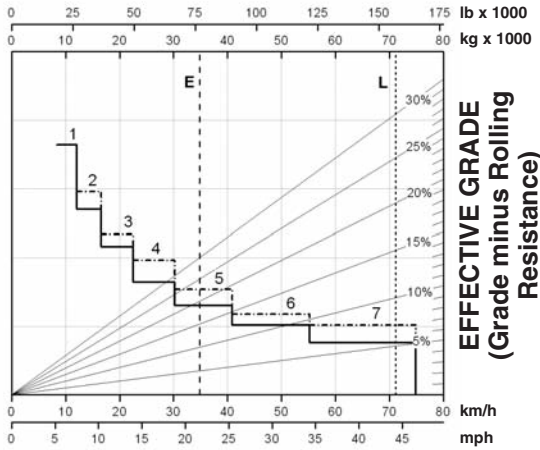

SPEED

GRADE DISTANCE — 450 m (1500 ft)

GROSS WEIGHT

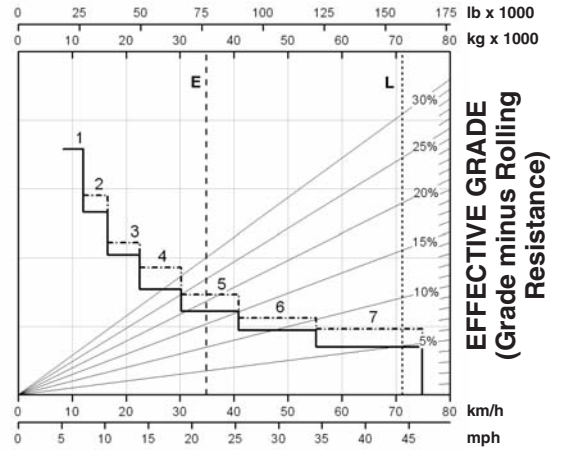

SPEED

GRADE DISTANCE — 600 m (2000 ft)

GROSS WEIGHT

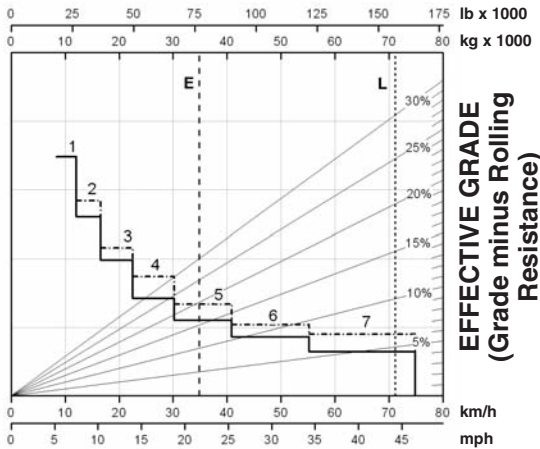

SPEED

GRADE DISTANCE — 900 m (3000 ft)

GROSS WEIGHT

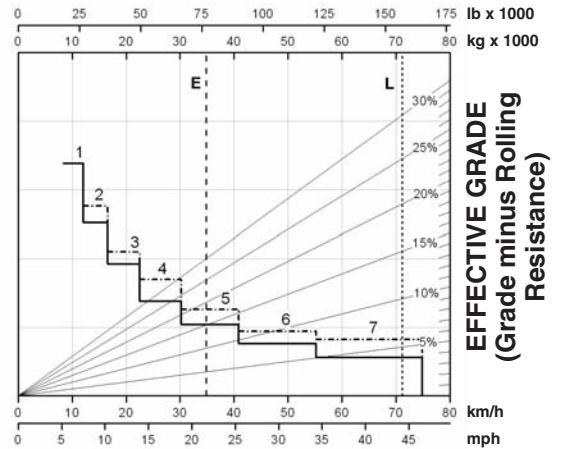

SPEED

GRADE DISTANCE — 1500 m (5000 ft)

KEY

- 1 — 1st Gear
- 2 — 2nd Gear
- 3 — 3rd Gear
- 4 — 4th Gear
- 5 — 5th Gear
- 6 — 6th Gear
- 7 — 7th Gear

KEY

- E — Empty 34 642 kg (76,372 lb)
- L — Target GMW 71 214 kg (157,000 lb)
- With ARC Only
- ARC and Engine Brake

**LOADED**

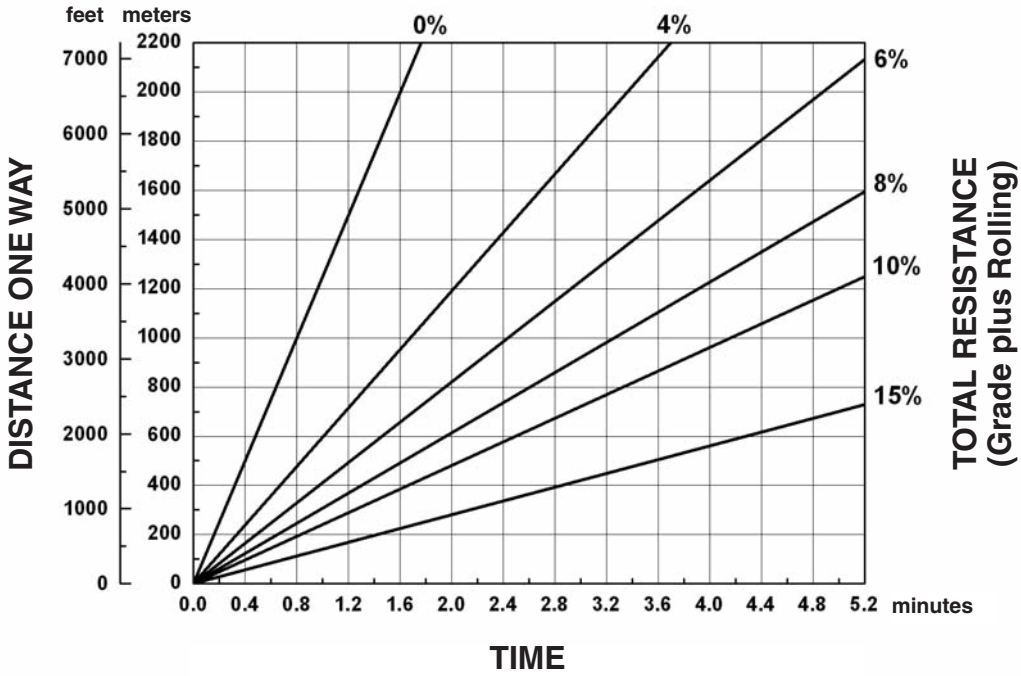

**EMPTY**

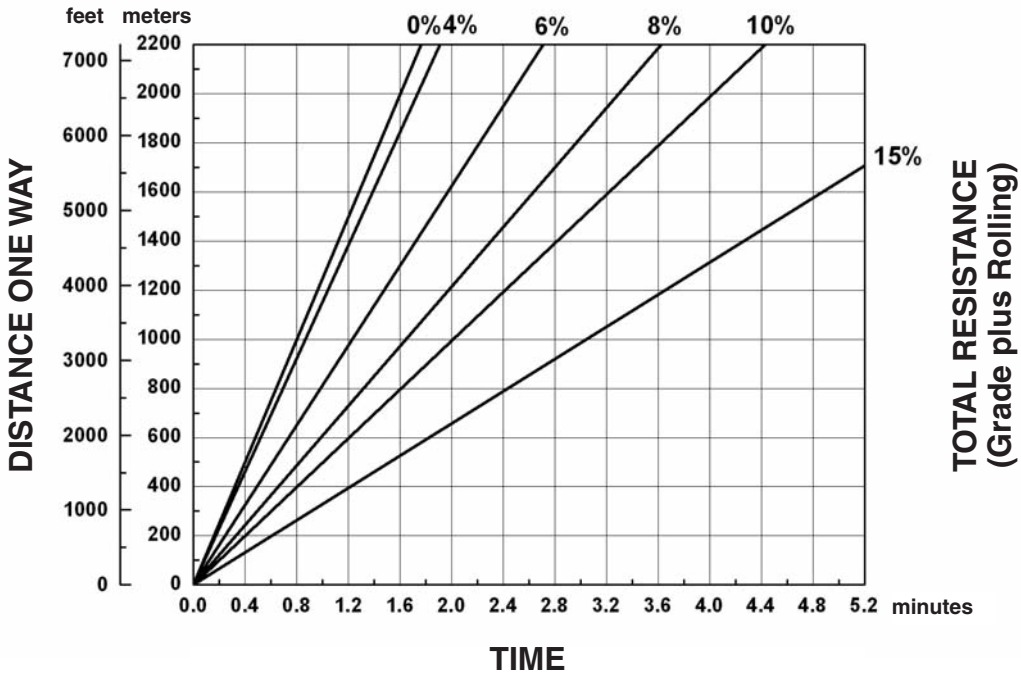

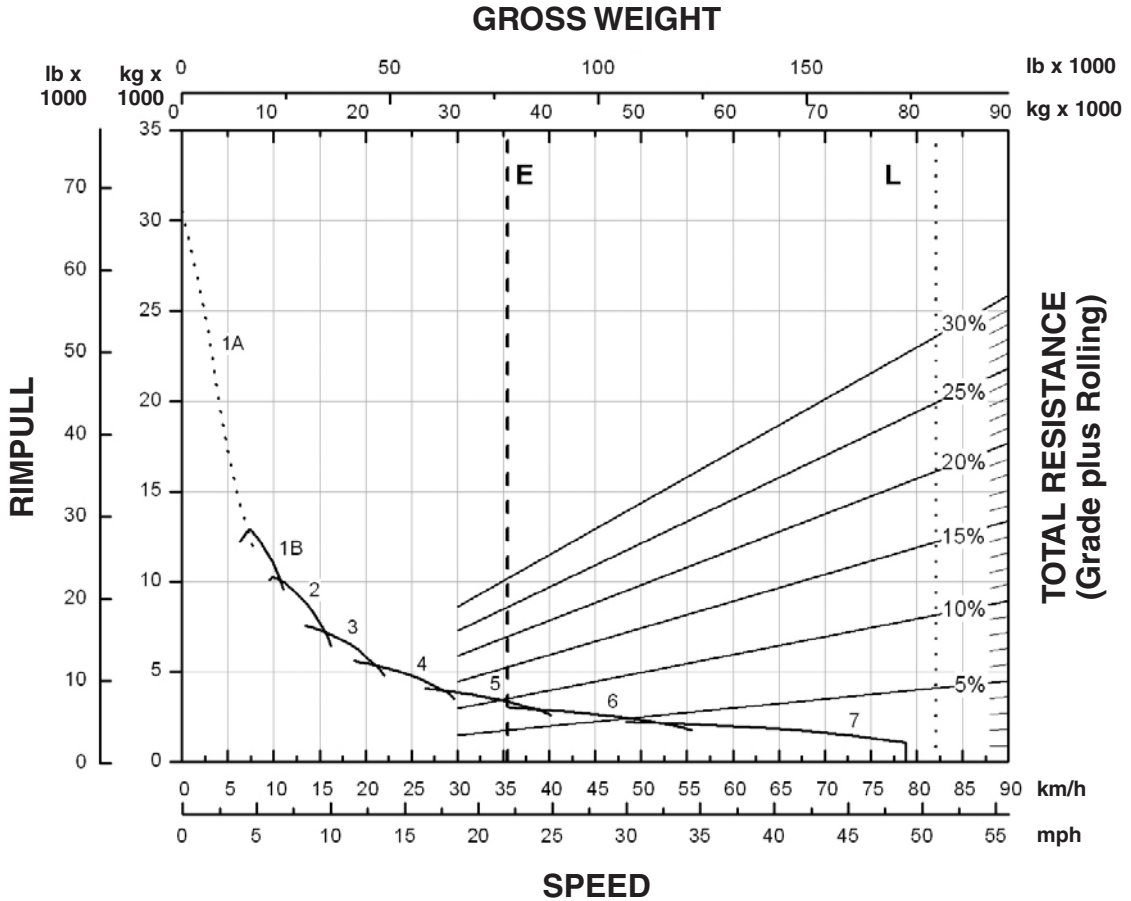

**KEY**

- 1A — 1st Gear (Torque Converter)
- 1B — 1st Gear
- 2 — 2nd Gear
- 3 — 3rd Gear
- 4 — 4th Gear
- 5 — 5th Gear
- 6 — 6th Gear
- 7 — 7th Gear

**KEY**

- E — Empty 35 864 kg (79,066 lb)
- L — Target GMW 82 100 kg (181,000 lb)

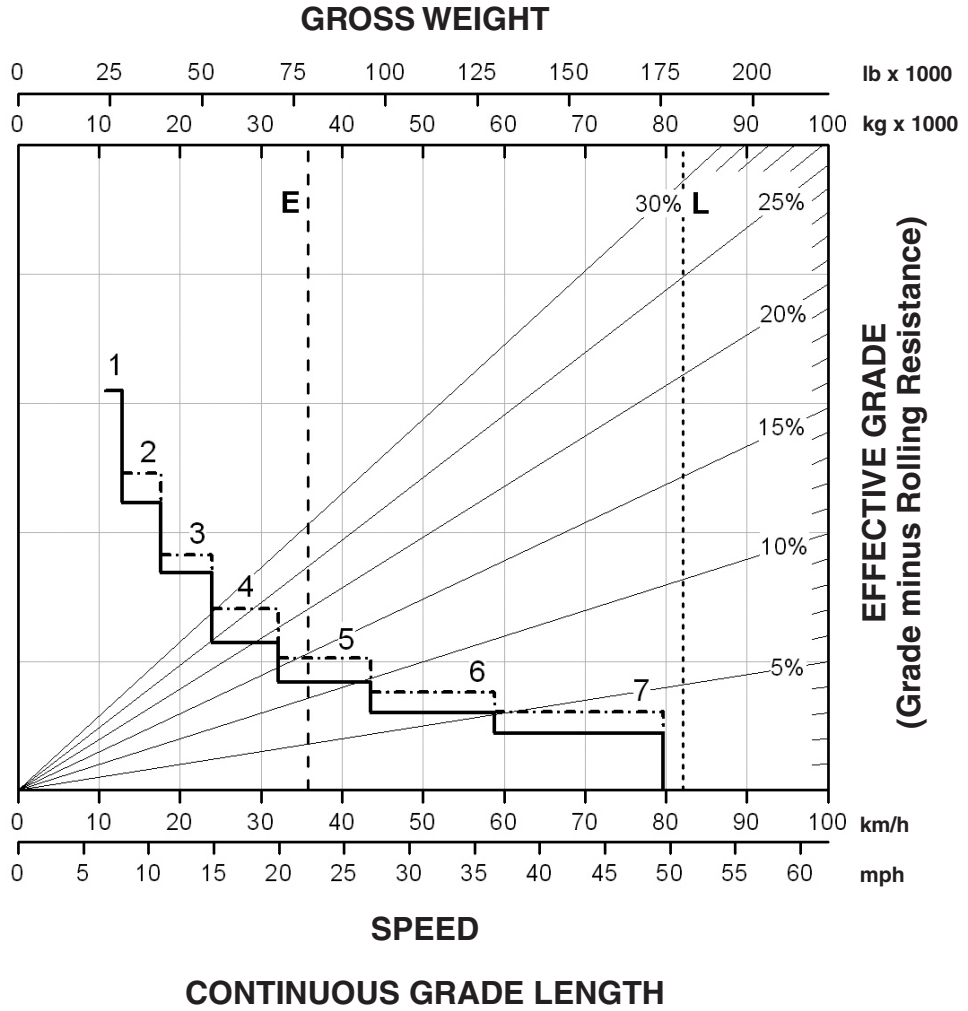

- KEY**
- 1 — 1st Gear
  - 2 — 2nd Gear
  - 3 — 3rd Gear
  - 4 — 4th Gear
  - 5 — 5th Gear
  - 6 — 6th Gear
  - 7 — 7th Gear

- KEY**
- E — Empty 35 864 kg (79,066 lb)
  - L — Target GMW 82 100 kg (181,000 lb)
  - With ARC Only
  - - - - - ARC and Engine Brake

772 Brake Performance

- 450 m (1500 ft)
- 600 m (2000 ft)
- 900 m (3000 ft)
- 1500 m (5000 ft)

Construction & Mining Trucks

GROSS WEIGHT

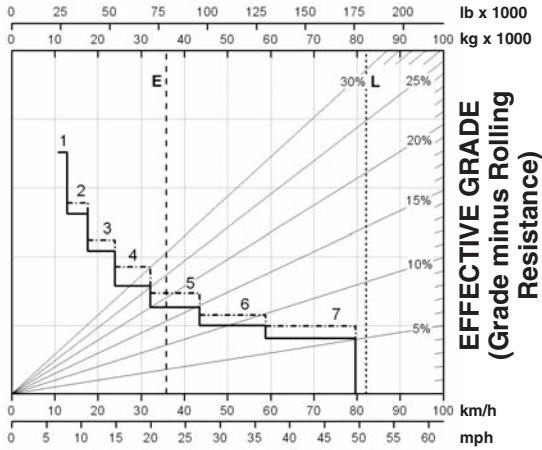

SPEED

GRADE DISTANCE — 450 m (1500 ft)

GROSS WEIGHT

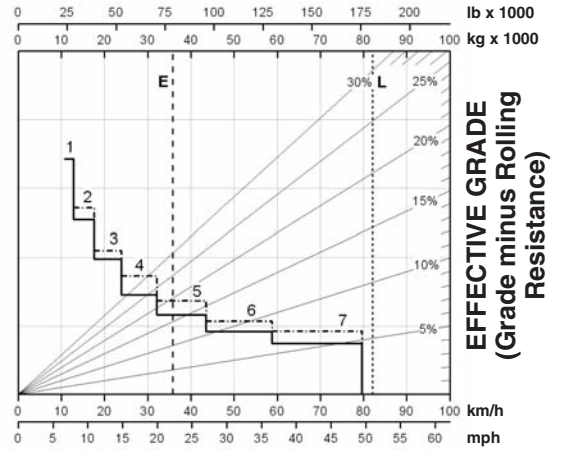

SPEED

GRADE DISTANCE — 600 m (2000 ft)

GROSS WEIGHT

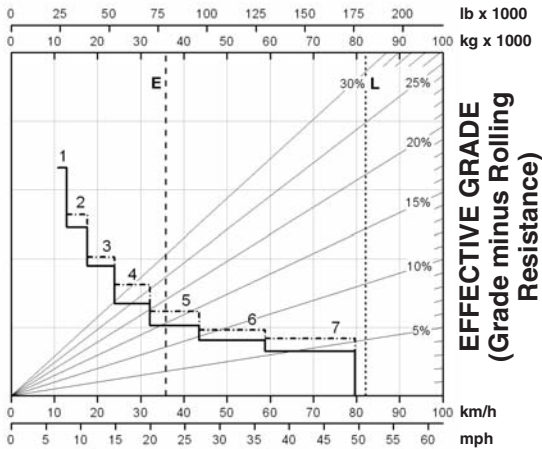

SPEED

GRADE DISTANCE — 900 m (3000 ft)

GROSS WEIGHT

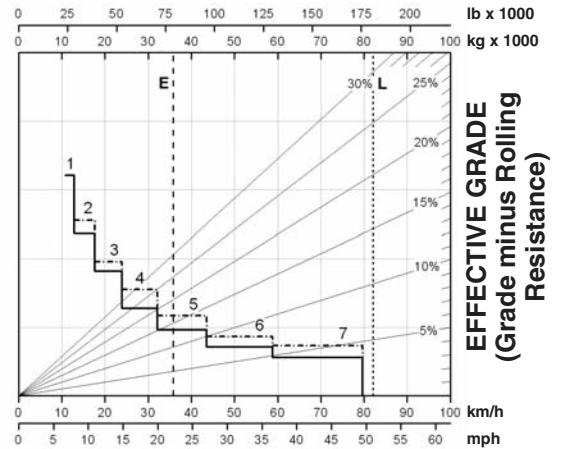

SPEED

GRADE DISTANCE — 1500 m (5000 ft)

KEY

- 1 — 1st Gear
- 2 — 2nd Gear
- 3 — 3rd Gear
- 4 — 4th Gear
- 5 — 5th Gear
- 6 — 6th Gear
- 7 — 7th Gear

KEY

- E — Empty 35 864 kg (79,066 lb)
- L — Target GMW 82 100 kg (181,000 lb)
- With ARC Only
- - - - - ARC and Engine Brake



**LOADED**

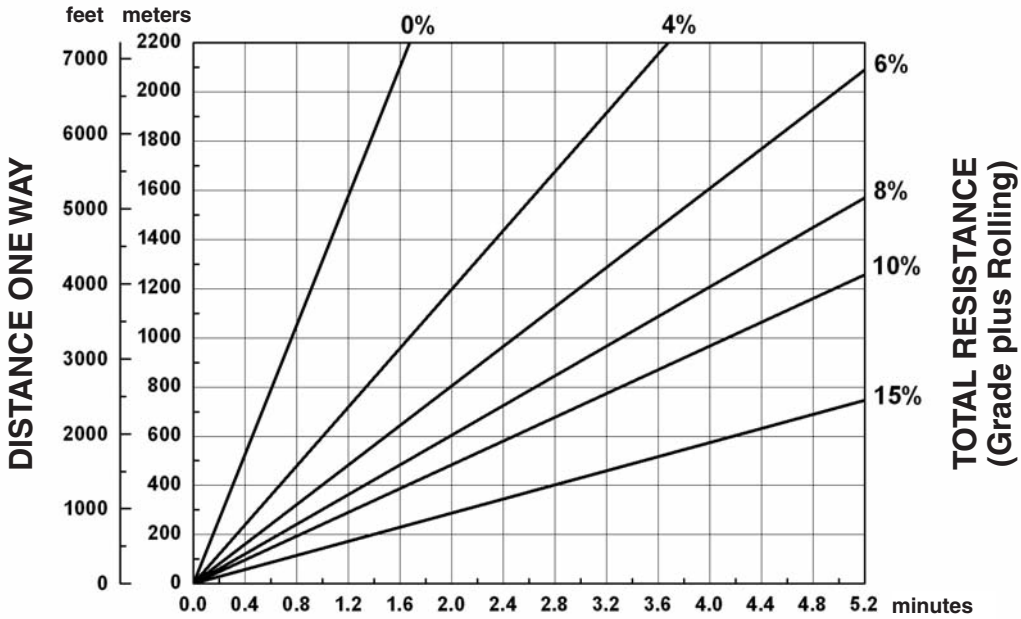

**EMPTY**

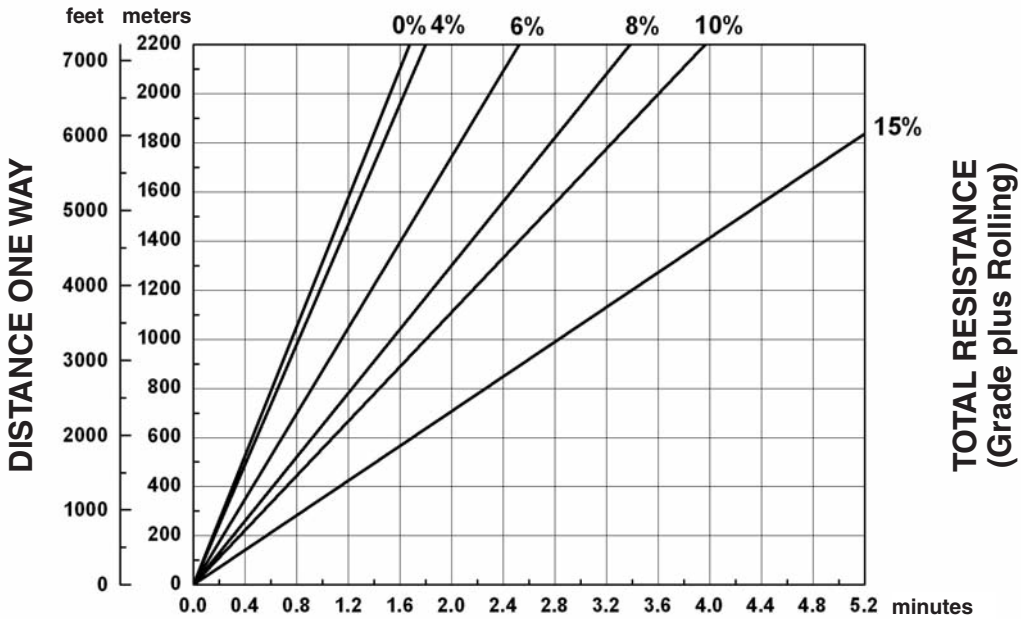

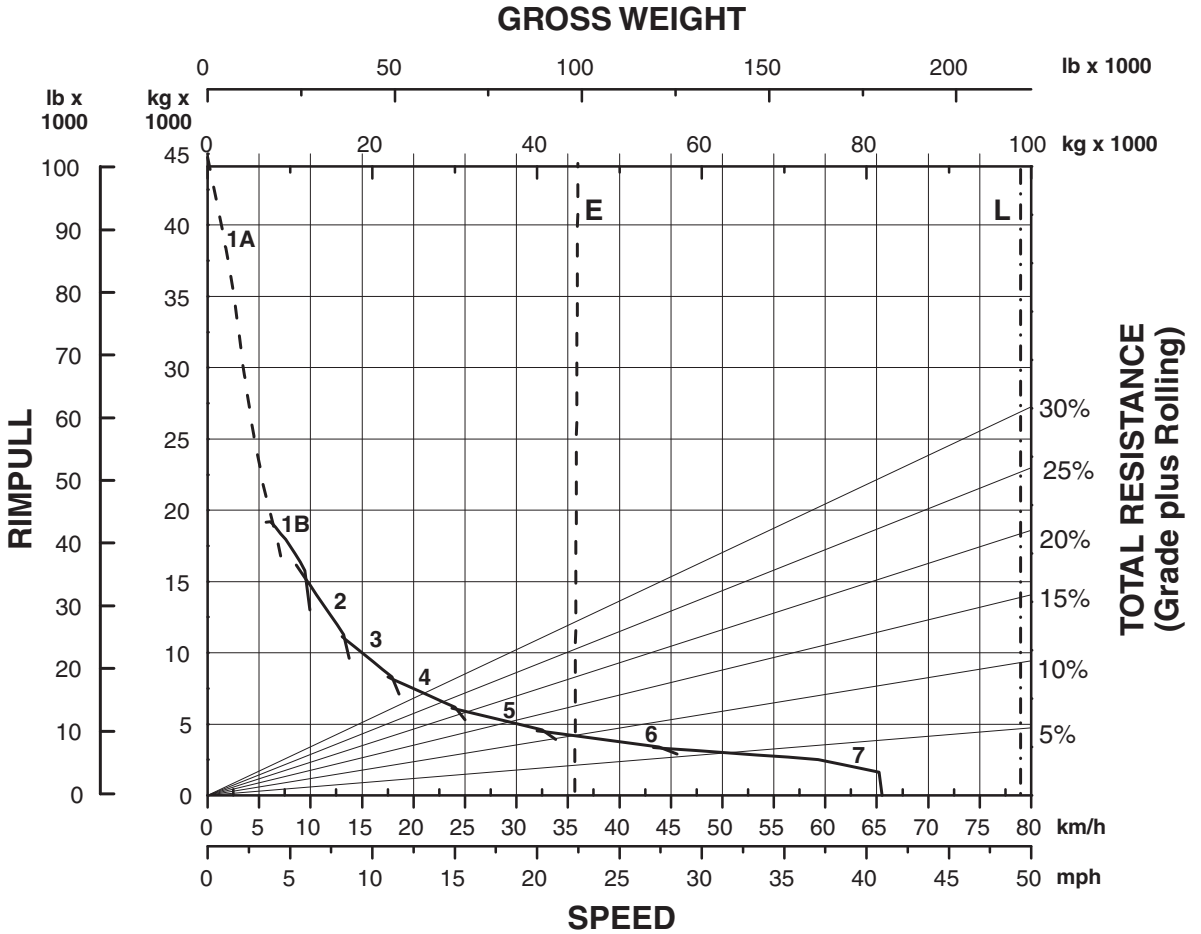

**KEY**

- 1A — 1st Gear (Torque Converter)
- 1B — 1st Gear
- 2 — 2nd Gear
- 3 — 3rd Gear
- 4 — 4th Gear
- 5 — 5th Gear
- 6 — 6th Gear
- 7 — 7th Gear

**KEY**

- E — Empty Weight 39 940 kg (88,053 lb)
- L — Target GMW 99 300 kg (219,000 lb)

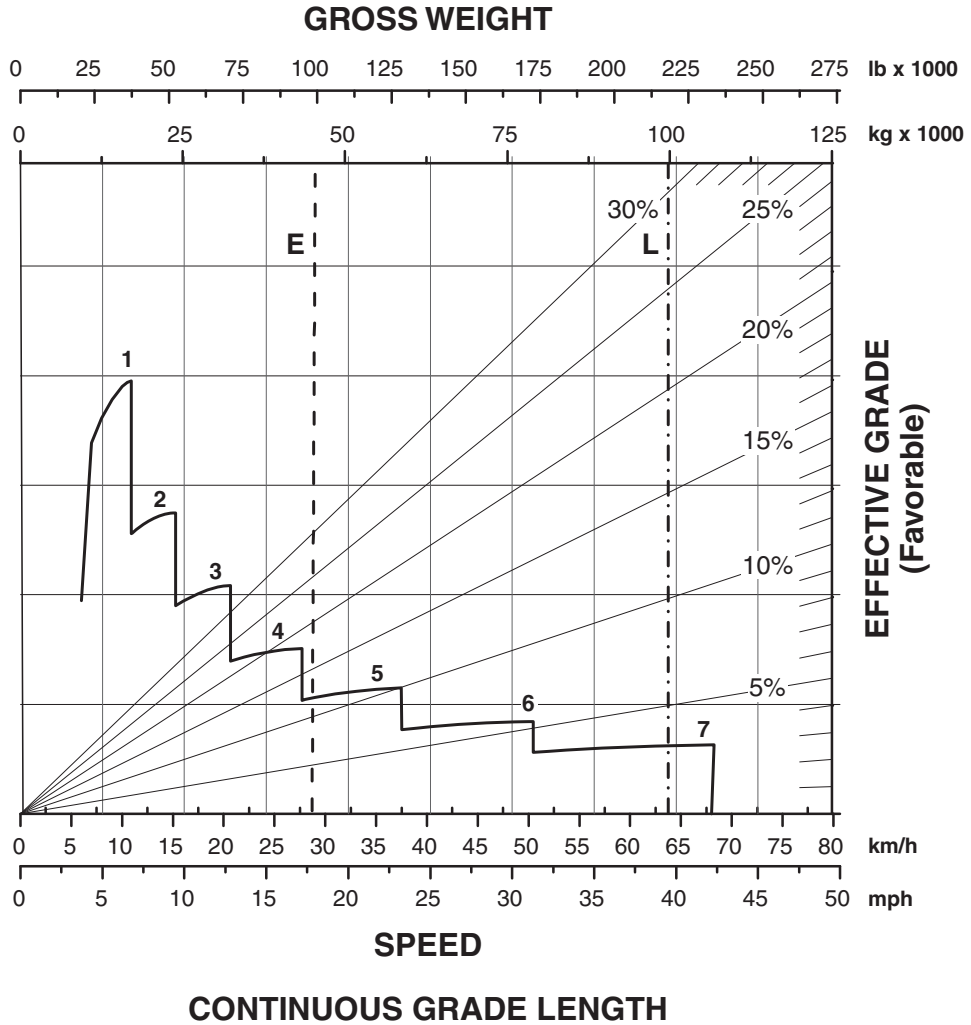

- KEY**
- 1 — 1st Gear
  - 2 — 2nd Gear
  - 3 — 3rd Gear
  - 4 — 4th Gear
  - 5 — 5th Gear
  - 6 — 6th Gear
  - 7 — 7th Gear

- KEY**
- E — Empty Weight 39 940 kg (88,053 lb)
  - L — Target GMW 99 300 kg (219,000 lb)

### 773E Brake Performance

- 450 m (1500 ft)
- 600 m (2000 ft)
- 900 m (3000 ft)
- 1500 m (5000 ft)

### Construction & Mining Trucks

#### GROSS WEIGHT

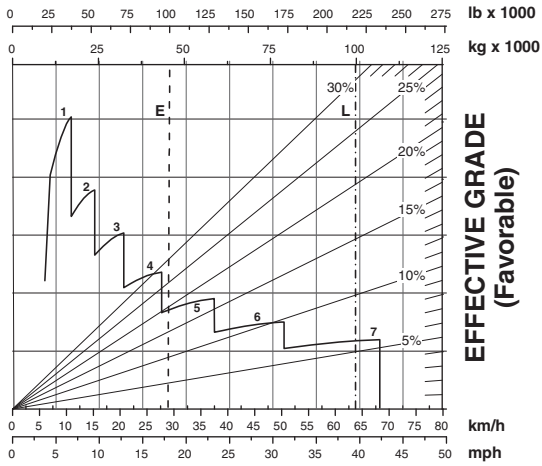

**SPEED**  
GRADE DISTANCE — 450 m (1500 ft)

#### GROSS WEIGHT

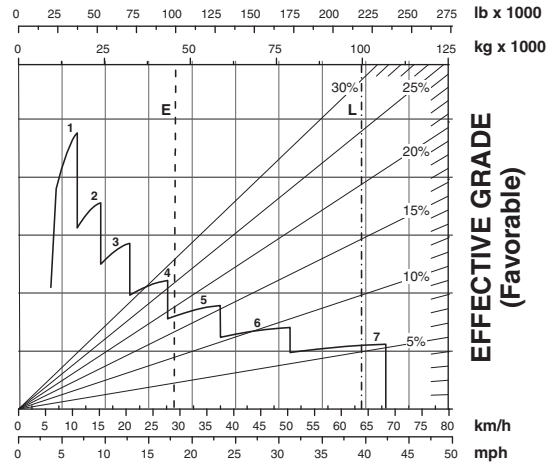

**SPEED**  
GRADE DISTANCE — 600 m (2000 ft)

#### GROSS WEIGHT

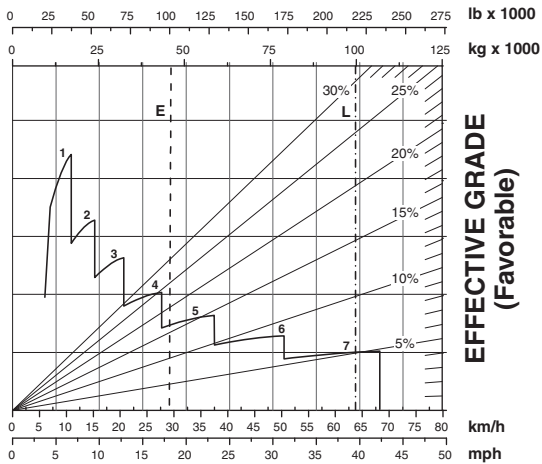

**SPEED**  
GRADE DISTANCE — 900 m (3000 ft)

#### GROSS WEIGHT

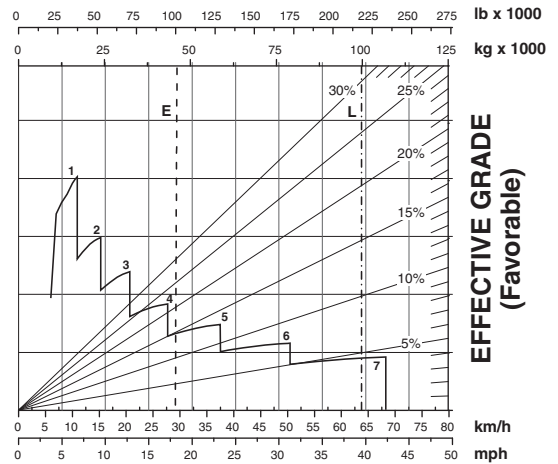

**SPEED**  
GRADE DISTANCE — 1500 m (5000 ft)

#### KEY

- 1 — 1st Gear
- 2 — 2nd Gear
- 3 — 3rd Gear
- 4 — 4th Gear
- 5 — 5th Gear
- 6 — 6th Gear
- 7 — 7th Gear

#### KEY

- E — Empty Weight 39 940 kg (88,053 lb)
- L — Target GMW 99 300 kg (219,000 lb)

**LOADED**

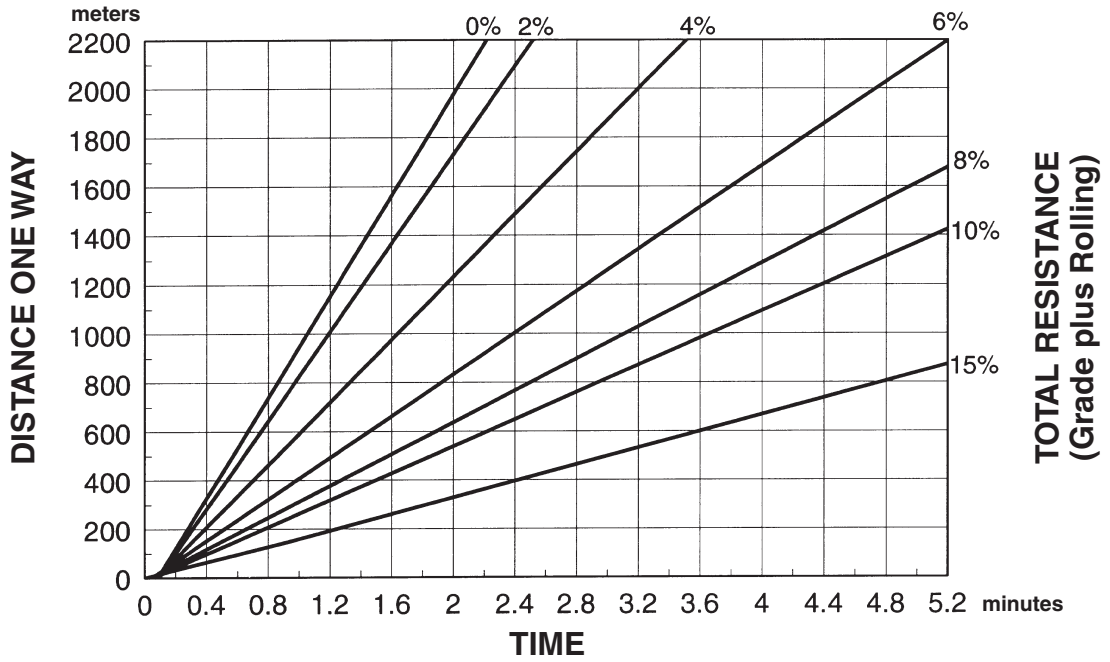

**EMPTY**

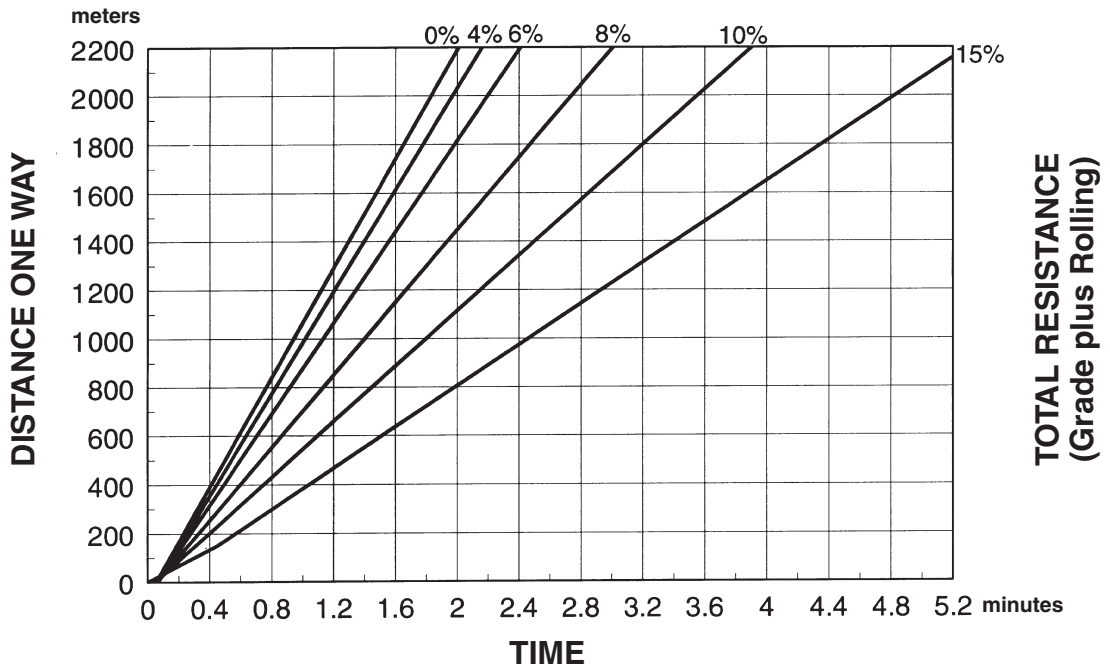

**GROSS WEIGHT**

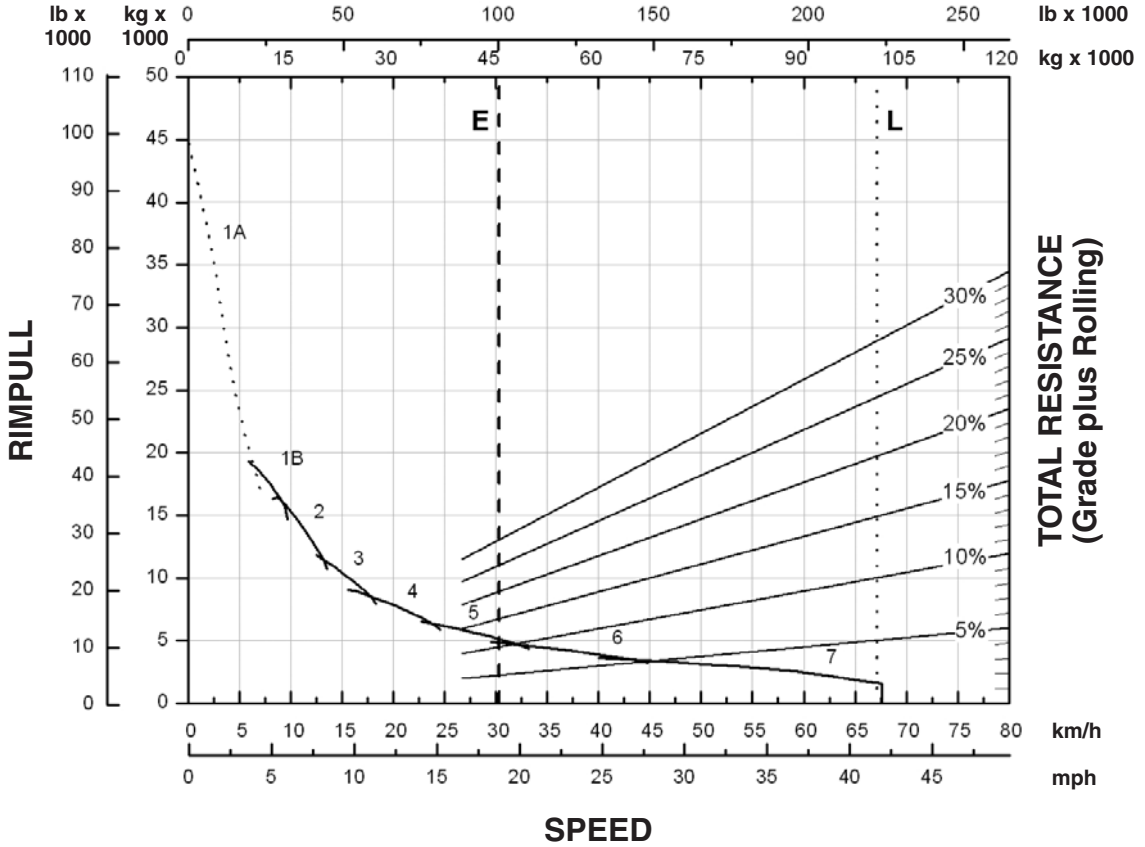

**KEY**

- 1A — 1st Gear (Torque Converter)
- 1B — 1st Gear
- 2 — 2nd Gear
- 3 — 3rd Gear
- 4 — 4th Gear
- 5 — 5th Gear
- 6 — 6th Gear
- 7 — 7th Gear

**KEY**

- E — Empty 45 647 kg (100,633 lb)
- L — Target GMW 100 698 kg (222,000 lb)

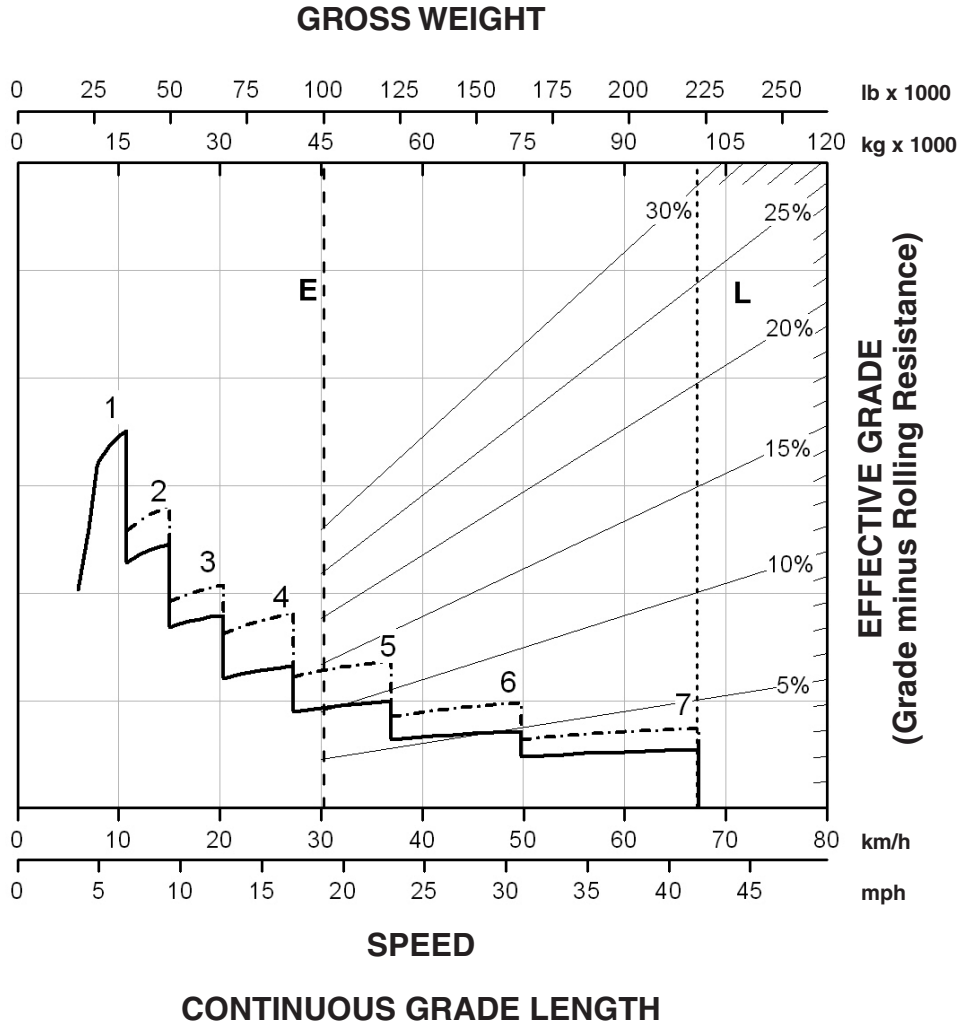

**KEY**

- 1 — 1st Gear
- 2 — 2nd Gear
- 3 — 3rd Gear
- 4 — 4th Gear
- 5 — 5th Gear
- 6 — 6th Gear
- 7 — 7th Gear

**KEY**

- E — Empty 45 647 kg (100,633 lb)
- L — Target GMW 100 698 kg (222,000 lb)
- With ARC Only
- - - - - ARC and Engine Brake

773F Brake Performance

- 450 m (1500 ft)    ● 600 m (2000 ft)
- 900 m (3000 ft)    ● 1500 m (5000 ft)

Construction & Mining Trucks

GROSS WEIGHT

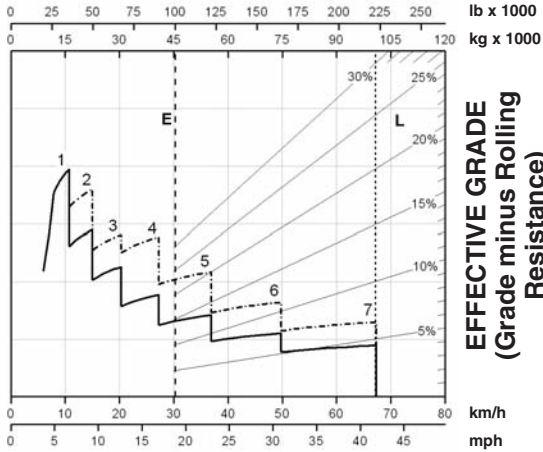

SPEED  
GRADE DISTANCE — 450 m (1500 ft)

GROSS WEIGHT

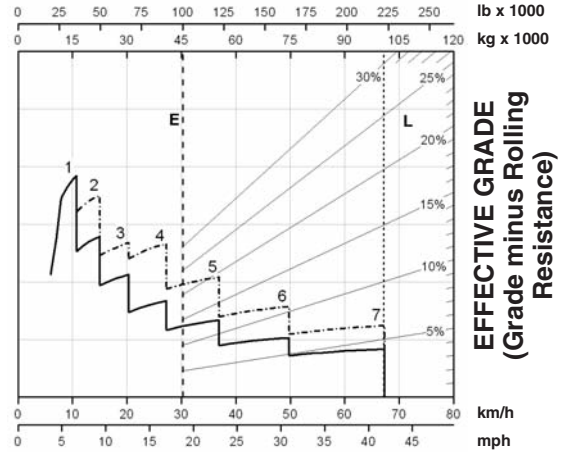

SPEED  
GRADE DISTANCE — 600 m (2000 ft)

GROSS WEIGHT

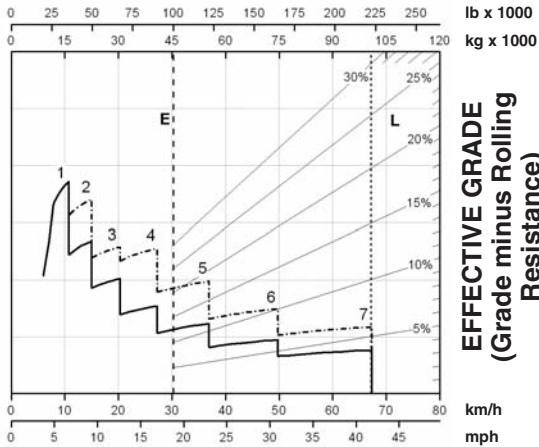

SPEED  
GRADE DISTANCE — 900 m (3000 ft)

GROSS WEIGHT

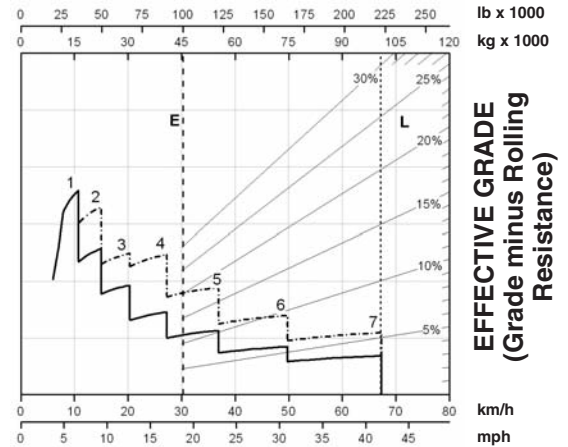

SPEED  
GRADE DISTANCE — 1500 m (5000 ft)

KEY

- 1 — 1st Gear
- 2 — 2nd Gear
- 3 — 3rd Gear
- 4 — 4th Gear
- 5 — 5th Gear
- 6 — 6th Gear
- 7 — 7th Gear

KEY

- E — Empty 45 647 kg (100,633 lb)
- L — Target GMW 100 698 kg (222,000 lb)
- With ARC Only
- - - - - ARC and Engine Brake



**LOADED**

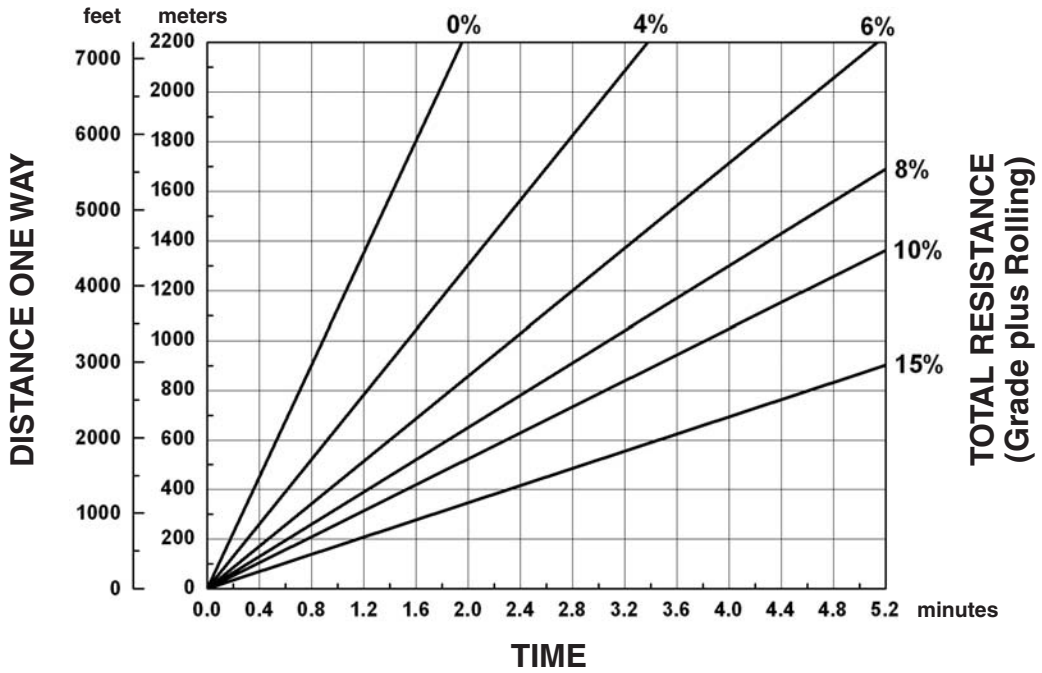

**EMPTY**

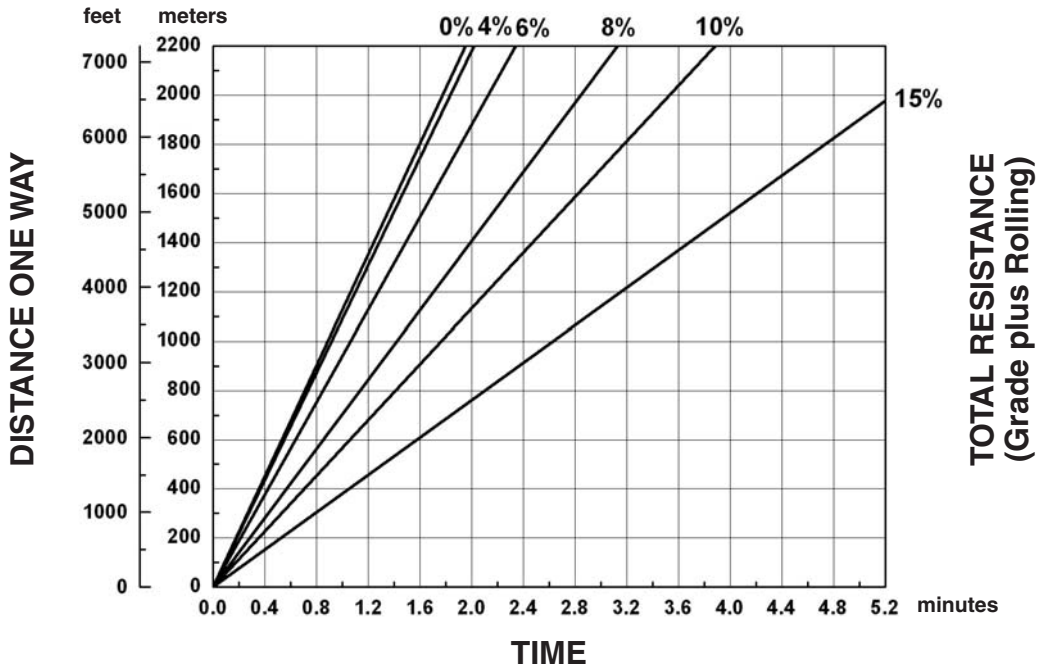

**GROSS WEIGHT**

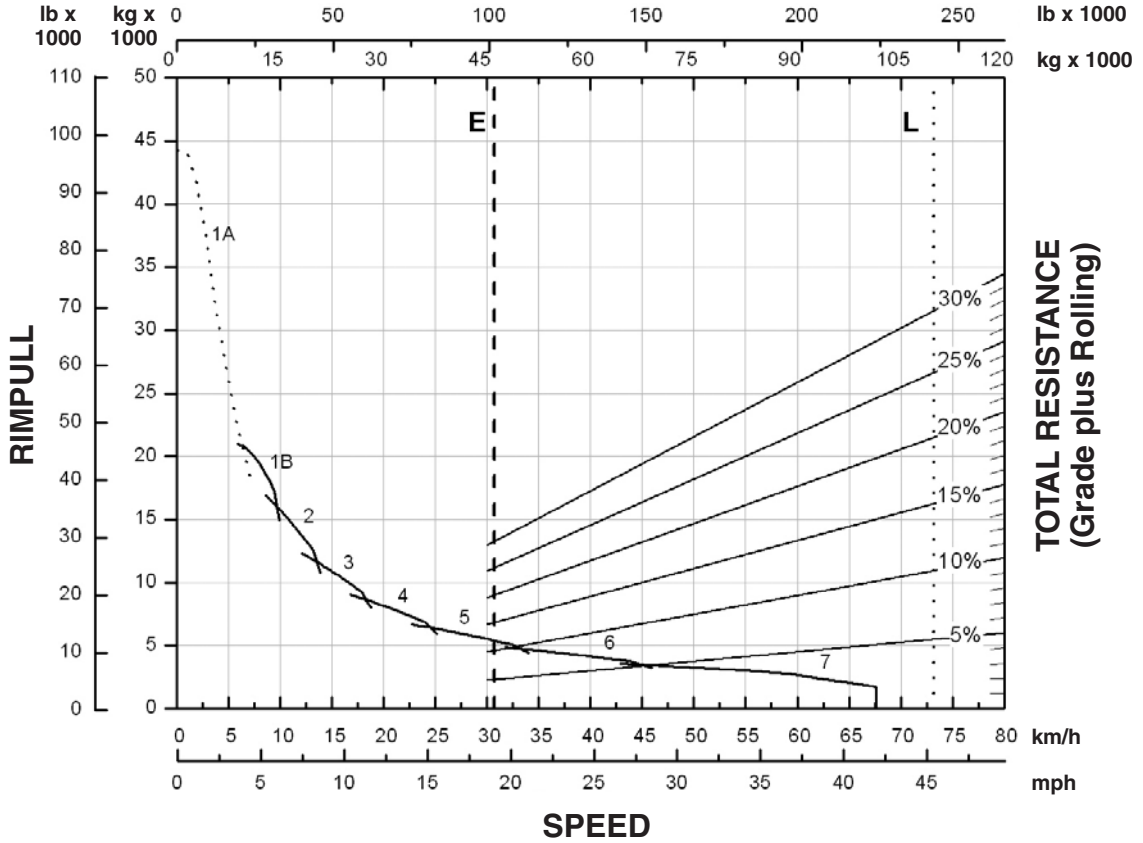

- KEY**
- 1A — 1st Gear (Torque Converter)
  - 1B — 1st Gear
  - 2 — 2nd Gear
  - 3 — 3rd Gear
  - 4 — 4th Gear
  - 5 — 5th Gear
  - 6 — 6th Gear
  - 7 — 7th Gear

- KEY**
- E — Empty 46 342 kg (102,165 lb)
  - L — Target GMW 109 769 kg (242,000 lb)

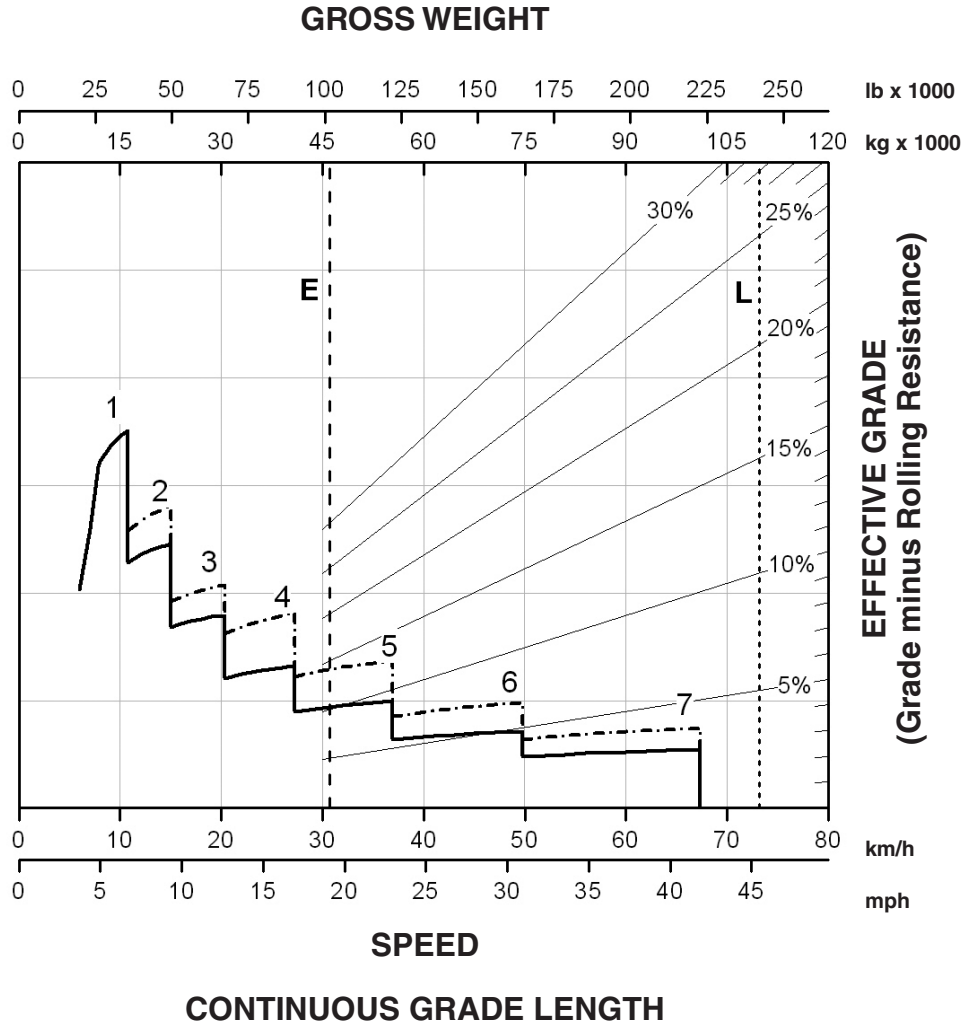

KEY

- 1 — 1st Gear
- 2 — 2nd Gear
- 3 — 3rd Gear
- 4 — 4th Gear
- 5 — 5th Gear
- 6 — 6th Gear
- 7 — 7th Gear

KEY

- E — Empty 46 342 kg (102,165 lb)
- L — Target GMW 109 769 kg (242,000 lb)
- With ARC Only
- - - - - ARC and Engine Brake

775F Brake Performance

- 450 m (1500 ft)
- 600 m (2000 ft)
- 900 m (3000 ft)
- 1500 m (5000 ft)

Construction & Mining Trucks

GROSS WEIGHT

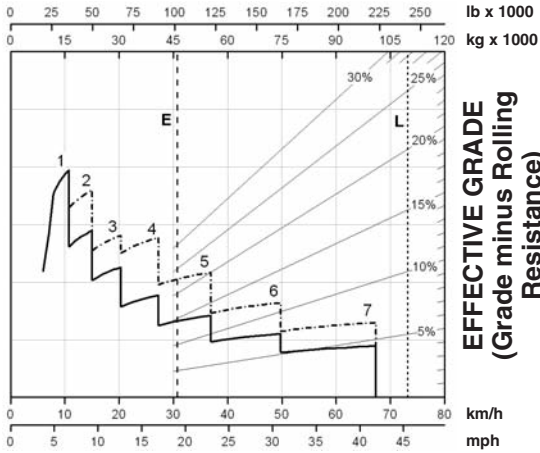

SPEED  
GRADE DISTANCE — 450 m (1500 ft)

GROSS WEIGHT

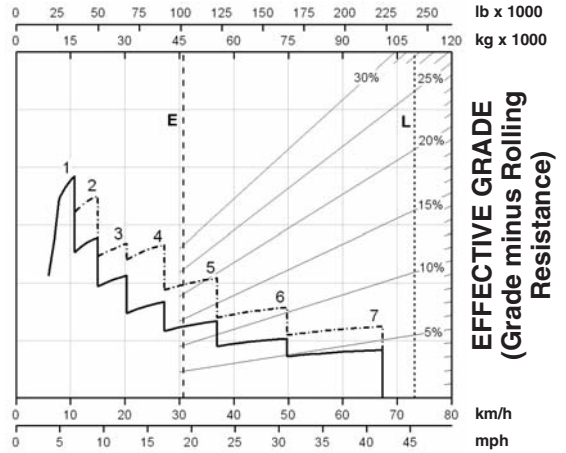

SPEED  
GRADE DISTANCE — 600 m (2000 ft)

GROSS WEIGHT

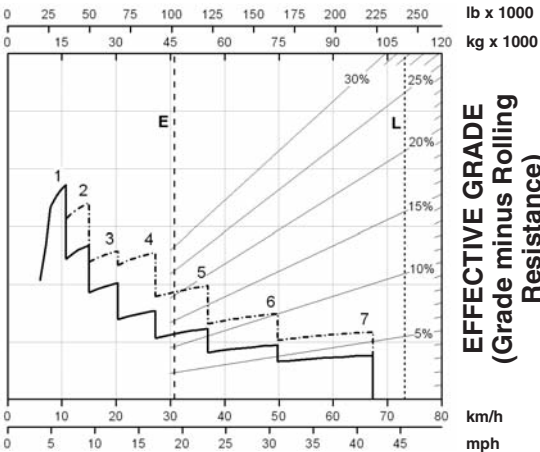

SPEED  
GRADE DISTANCE — 900 m (3000 ft)

GROSS WEIGHT

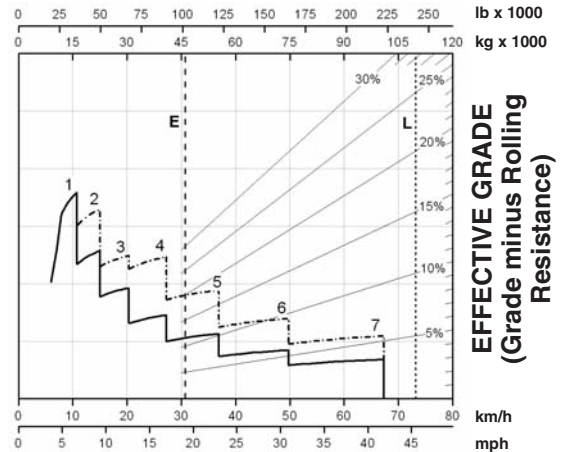

SPEED  
GRADE DISTANCE — 1500 m (5000 ft)

KEY

- 1 — 1st Gear
- 2 — 2nd Gear
- 3 — 3rd Gear
- 4 — 4th Gear
- 5 — 5th Gear
- 6 — 6th Gear
- 7 — 7th Gear

KEY

- E — Empty 46 342 kg (102,165 lb)
- L — Target GMW 109 769 kg (242,000 lb)
- With ARC Only
- ARC and Engine Brake

**LOADED**

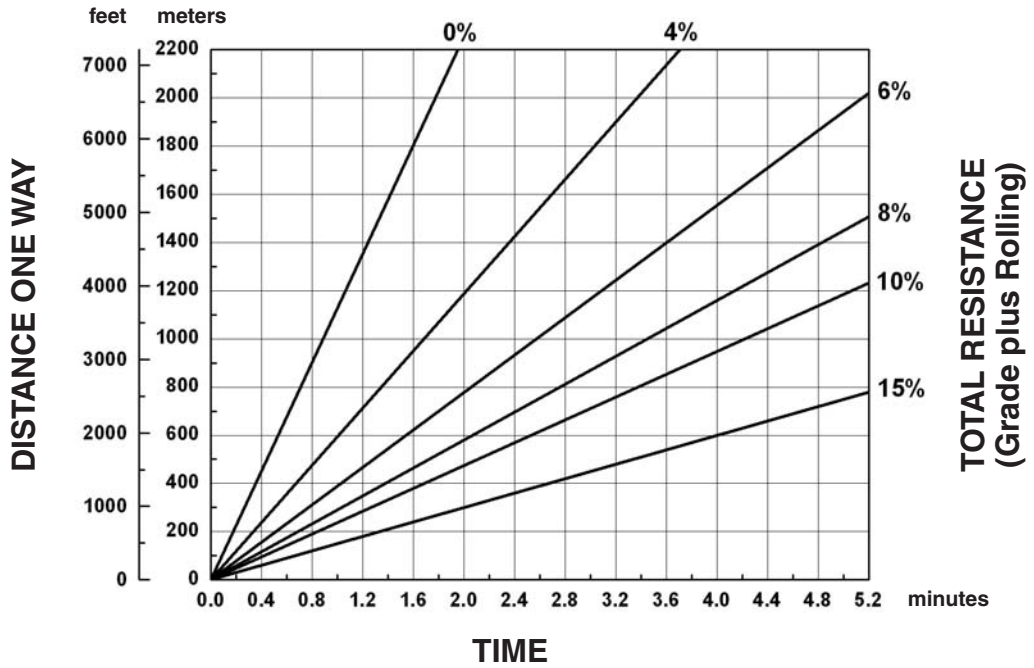

**EMPTY**

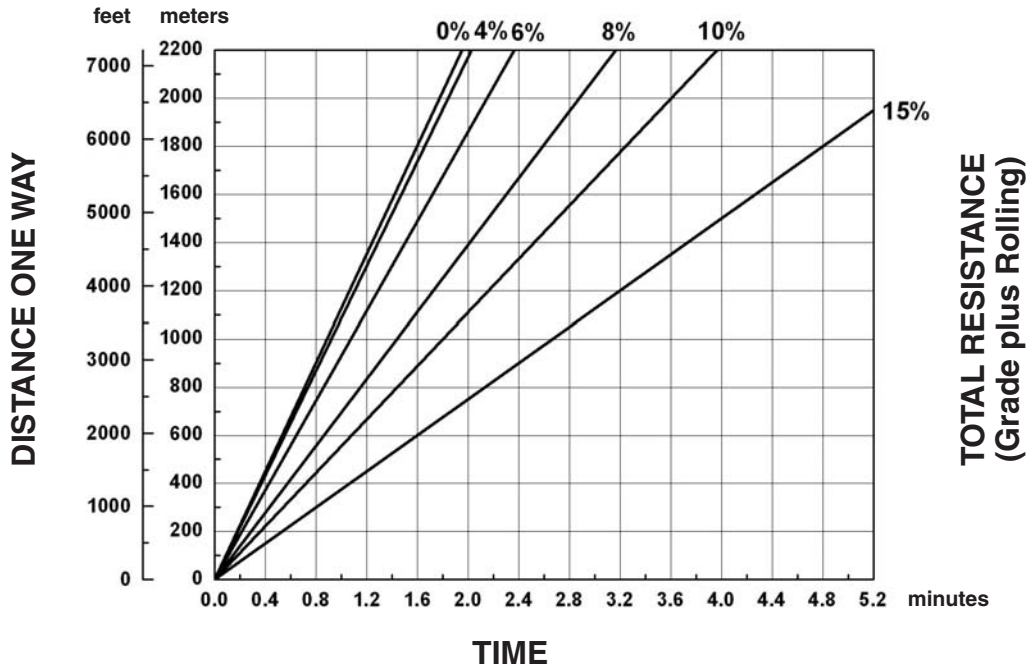

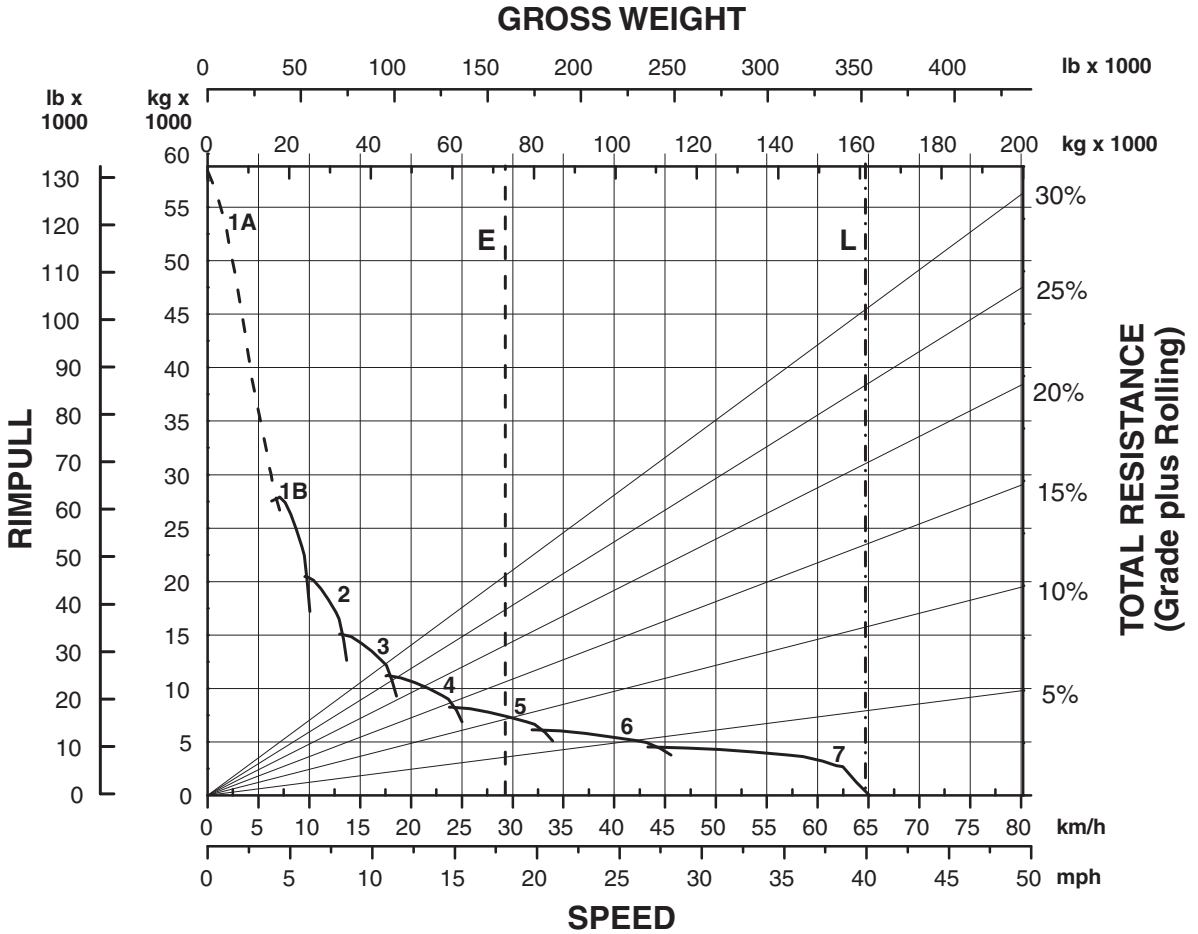

**KEY**

- 1A — 1st Gear (Torque Converter)
- 1B — 1st Gear
- 2 — 2nd Gear
- 3 — 3rd Gear
- 4 — 4th Gear
- 5 — 5th Gear
- 6 — 6th Gear
- 7 — 7th Gear

**KEY**

- E — Empty 64 359 kg (141,889 lb)
- L — Max GMW 163 360 kg (360,149 lb)

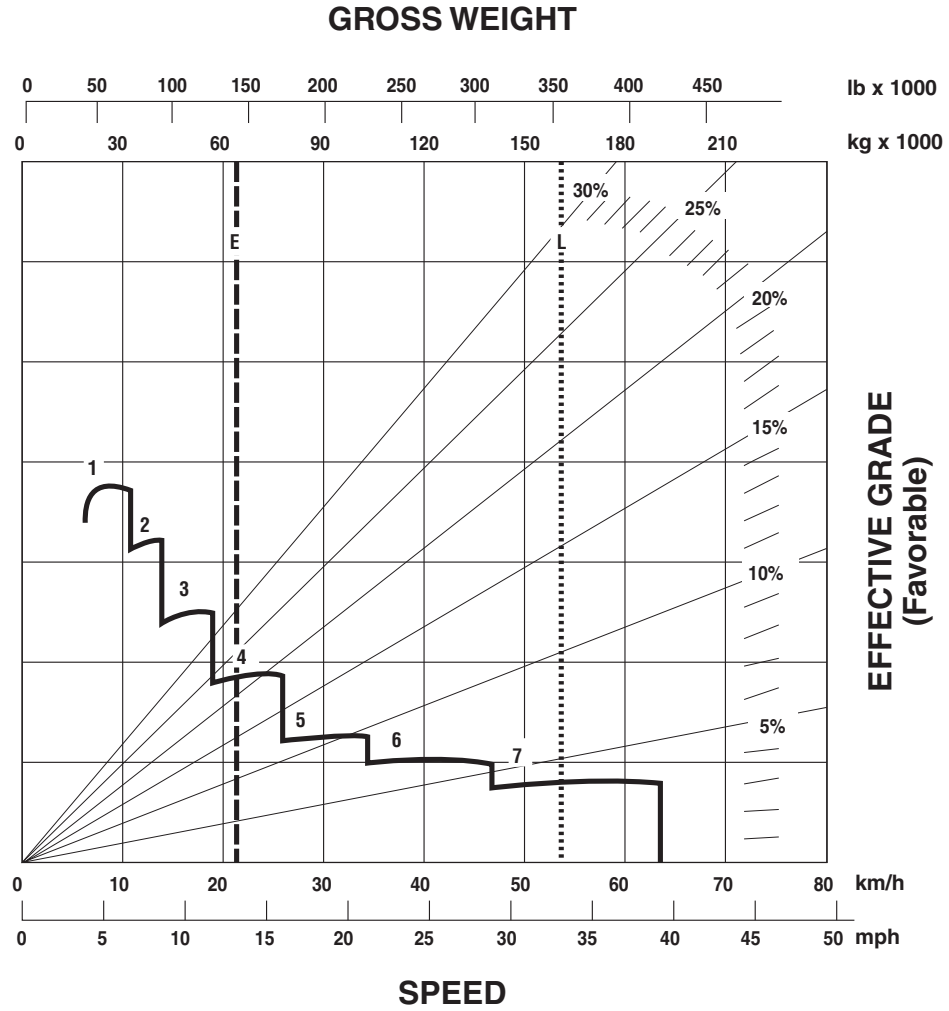

### CONTINUOUS GRADE LENGTH

**KEY**

- 1 — 1st Gear
- 2 — 2nd Gear
- 3 — 3rd Gear
- 4 — 4th Gear
- 5 — 5th Gear
- 6 — 6th Gear
- 7 — 7th Gear

**KEY**

- E — Empty 64 359 kg (141,889 lb)
- L — Max GMW 163 360 kg (360,149 lb)

# 777D Brake Performance

- 450 m (1500 ft)
- 600 m (2000 ft)
- 900 m (3000 ft)
- 1500 m (5000 ft)

# Construction & Mining Trucks

## GROSS WEIGHT

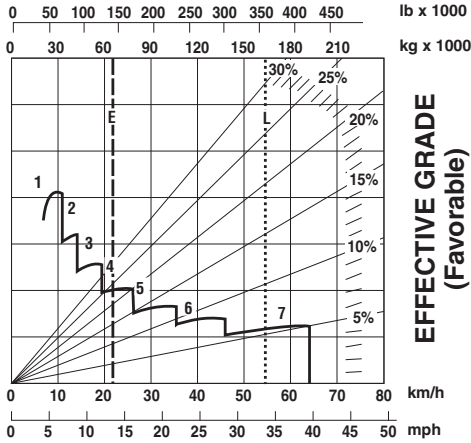

GRADE DISTANCE — 450 m (1500 ft)

## GROSS WEIGHT

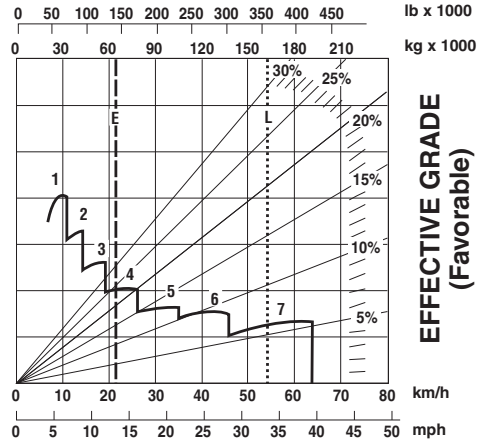

GRADE DISTANCE — 600 m (2000 ft)

## GROSS WEIGHT

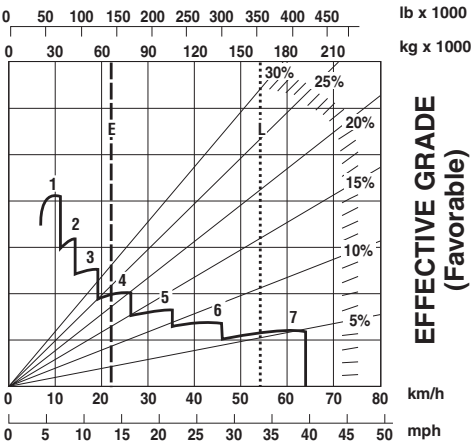

GRADE DISTANCE — 900 m (3000 ft)

## GROSS WEIGHT

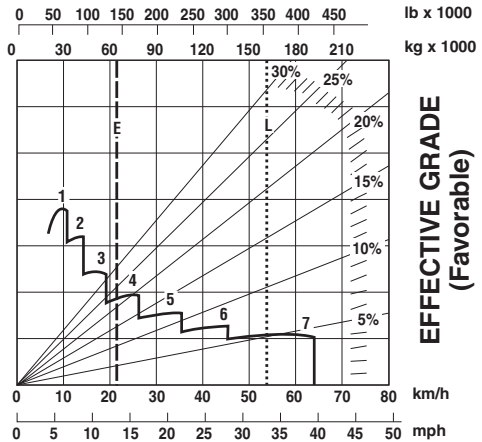

GRADE DISTANCE — 1500 m (5000 ft)

### KEY

- 1 — 1st Gear
- 2 — 2nd Gear
- 3 — 3rd Gear
- 4 — 4th Gear
- 5 — 5th Gear
- 6 — 6th Gear
- 7 — 7th Gear

### KEY

- E — Empty 64 359 kg (141,889 lb)
- L — Max GMW 163 360 kg (360,149 lb)



**LOADED**

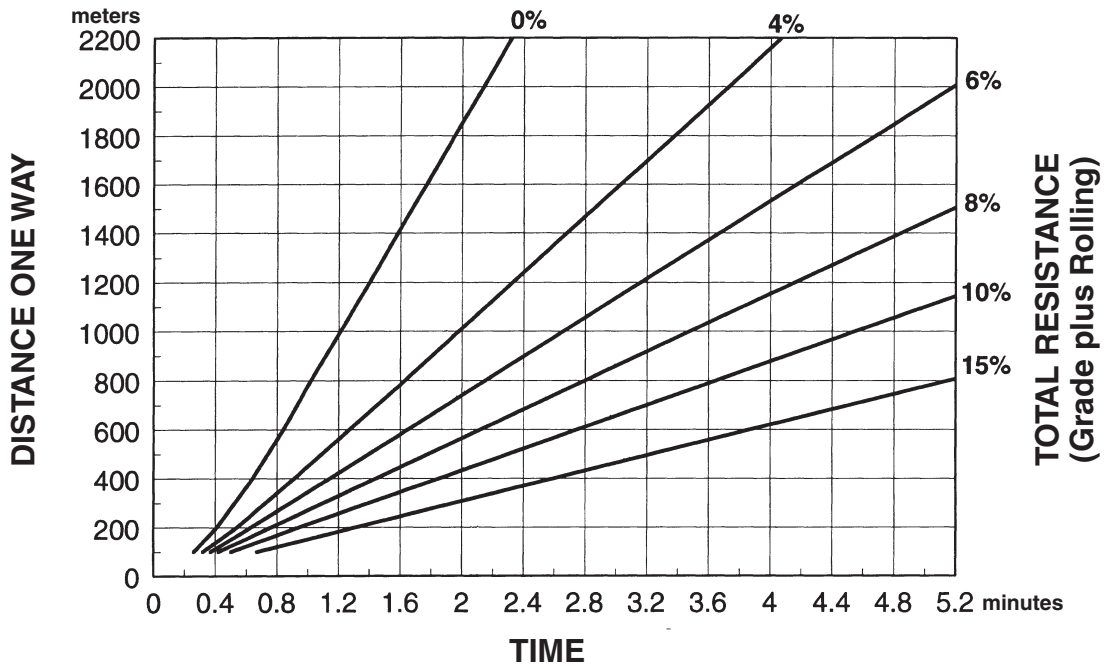

**EMPTY**

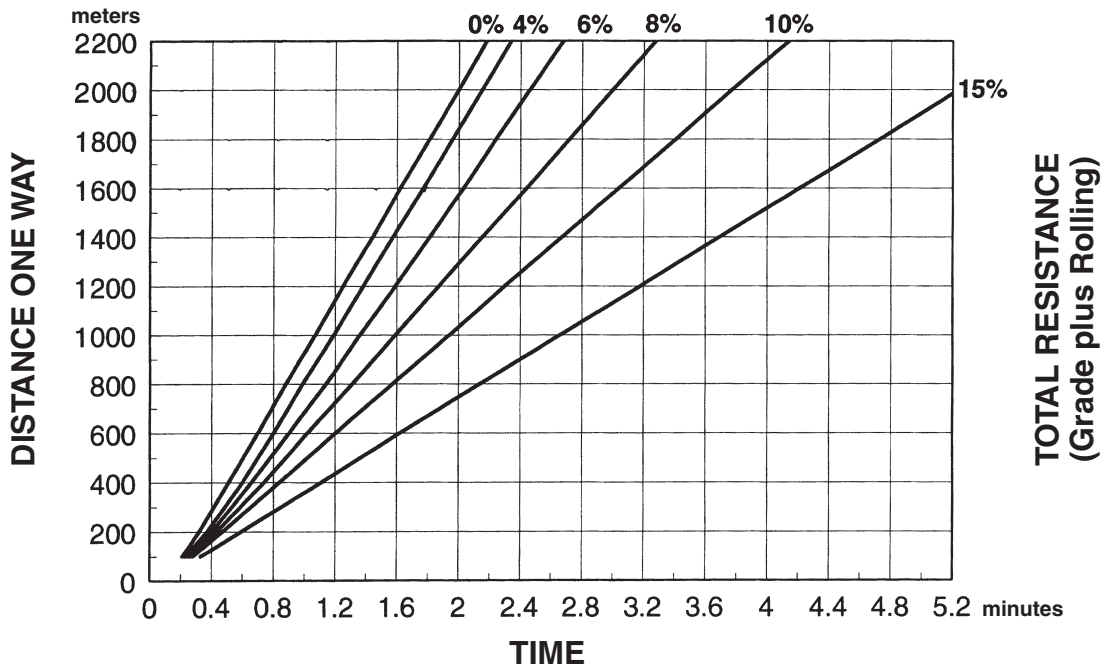

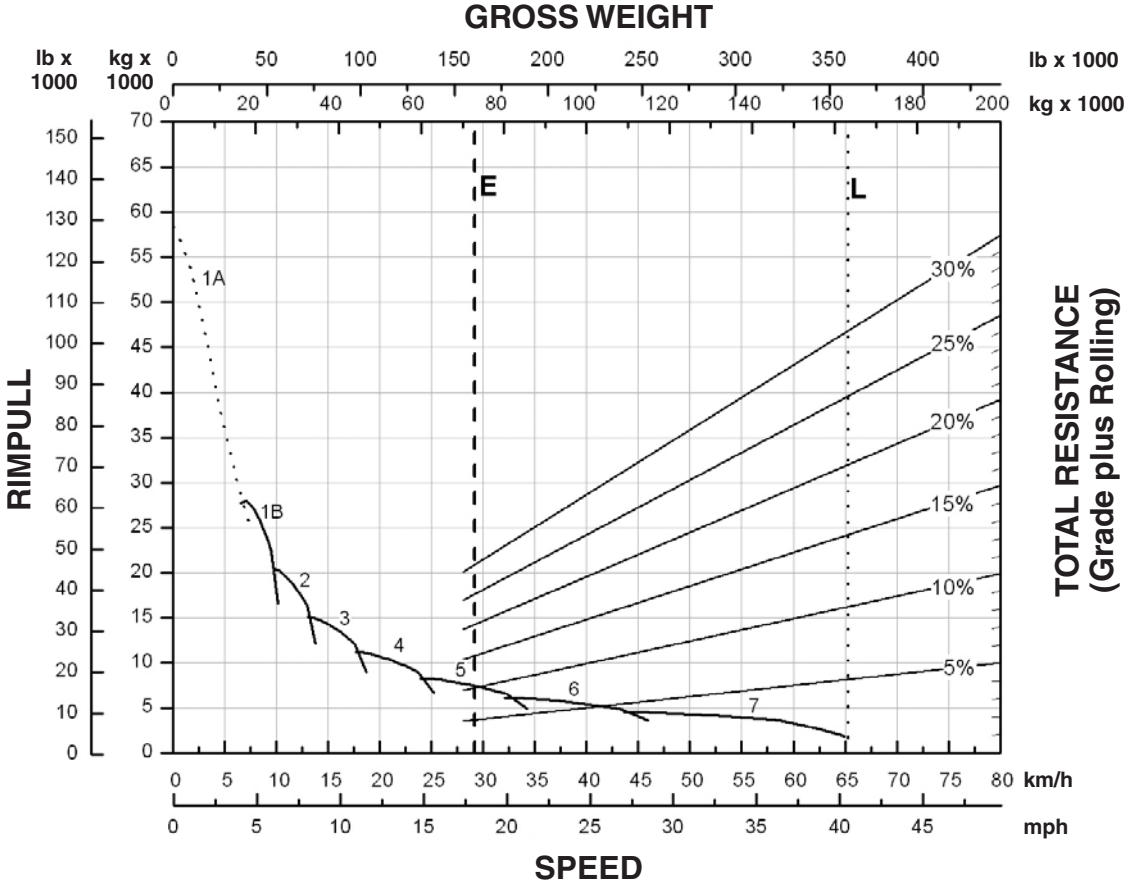

**KEY**

- 1A — 1st Gear (Torque Converter)
- 1B — 1st Gear
- 2 — 2nd Gear
- 3 — 3rd Gear
- 4 — 4th Gear
- 5 — 5th Gear
- 6 — 6th Gear
- 7 — 7th Gear

**KEY**

- E — Empty 72 977 kg (160,885 lb)
- L — Target GMW 163 293 kg (360,000 lb)

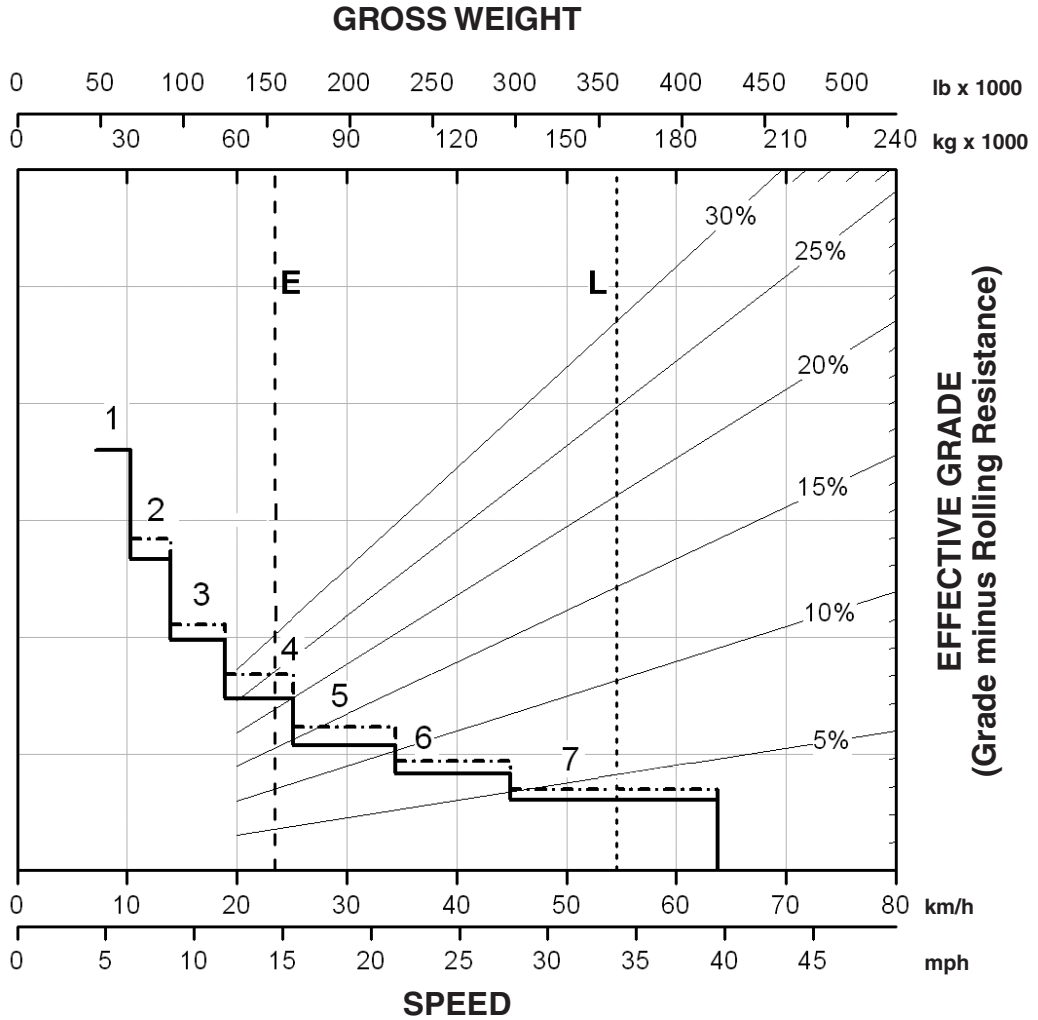

**CONTINUOUS GRADE LENGTH**

**KEY**

- 1 — 1st Gear
- 2 — 2nd Gear
- 3 — 3rd Gear
- 4 — 4th Gear
- 5 — 5th Gear
- 6 — 6th Gear
- 7 — 7th Gear

**KEY**

- E — Empty 72 977 kg (160,885 lb)
- L — Target GMW 163 293 kg (360,000 lb)
- With ARC Only
- - - - - ARC and Engine Brake

777F Brake Performance

- 450 m (1500 ft)
- 600 m (2000 ft)
- 900 m (3000 ft)
- 1500 m (5000 ft)

Construction & Mining Trucks

GROSS WEIGHT

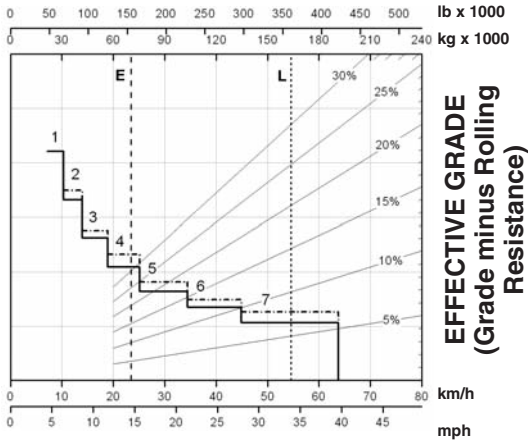

SPEED  
GRADE DISTANCE — 450 m (1500 ft)

GROSS WEIGHT

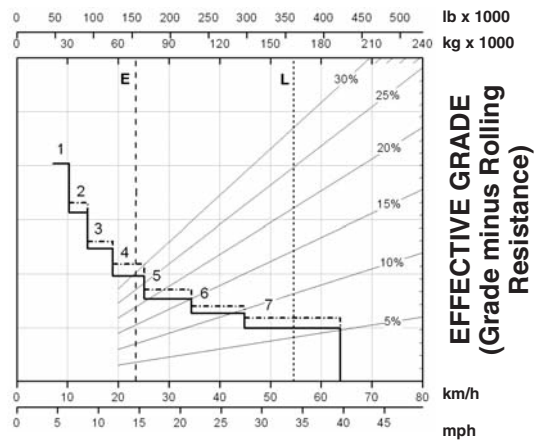

SPEED  
GRADE DISTANCE — 600 m (2000 ft)

GROSS WEIGHT

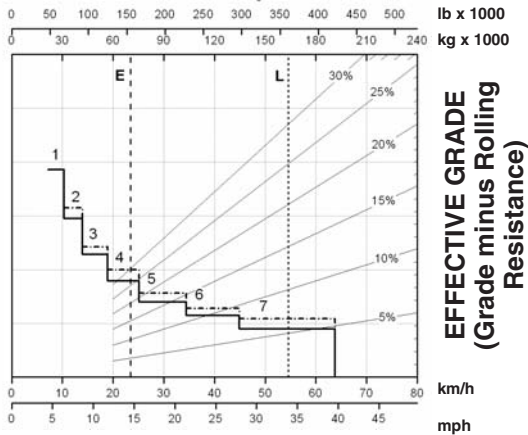

SPEED  
GRADE DISTANCE — 900 m (3000 ft)

GROSS WEIGHT

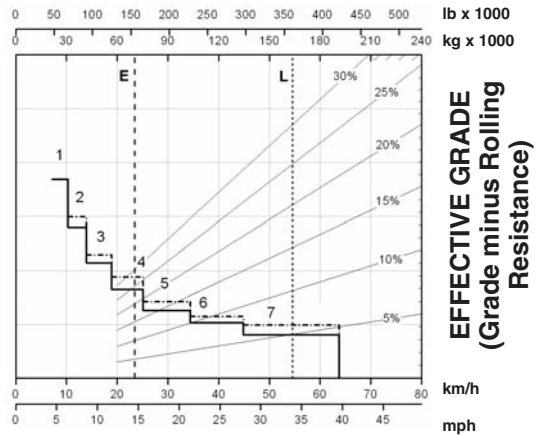

SPEED  
GRADE DISTANCE — 1500 m (5000 ft)

KEY

- 1 — 1st Gear
- 2 — 2nd Gear
- 3 — 3rd Gear
- 4 — 4th Gear
- 5 — 5th Gear
- 6 — 6th Gear
- 7 — 7th Gear

KEY

- E — Empty 72 977 kg (160,885 lb)
- L — Target GMW 163 293 kg (360,000 lb)
- With ARC Only
- ARC and Engine Brake

**LOADED**

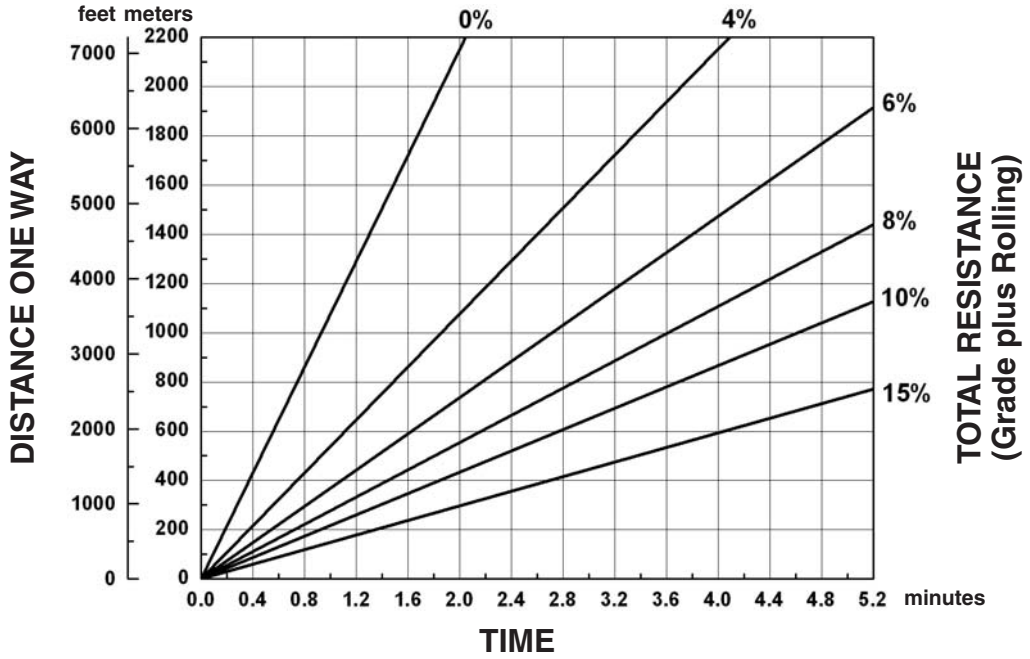

**EMPTY**

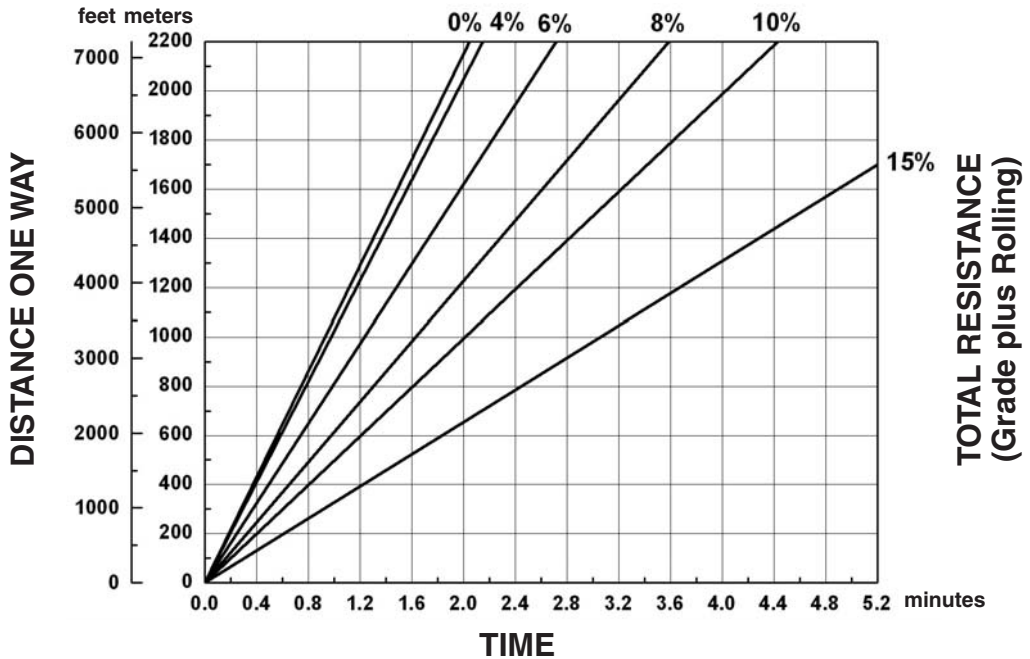

GROSS WEIGHT

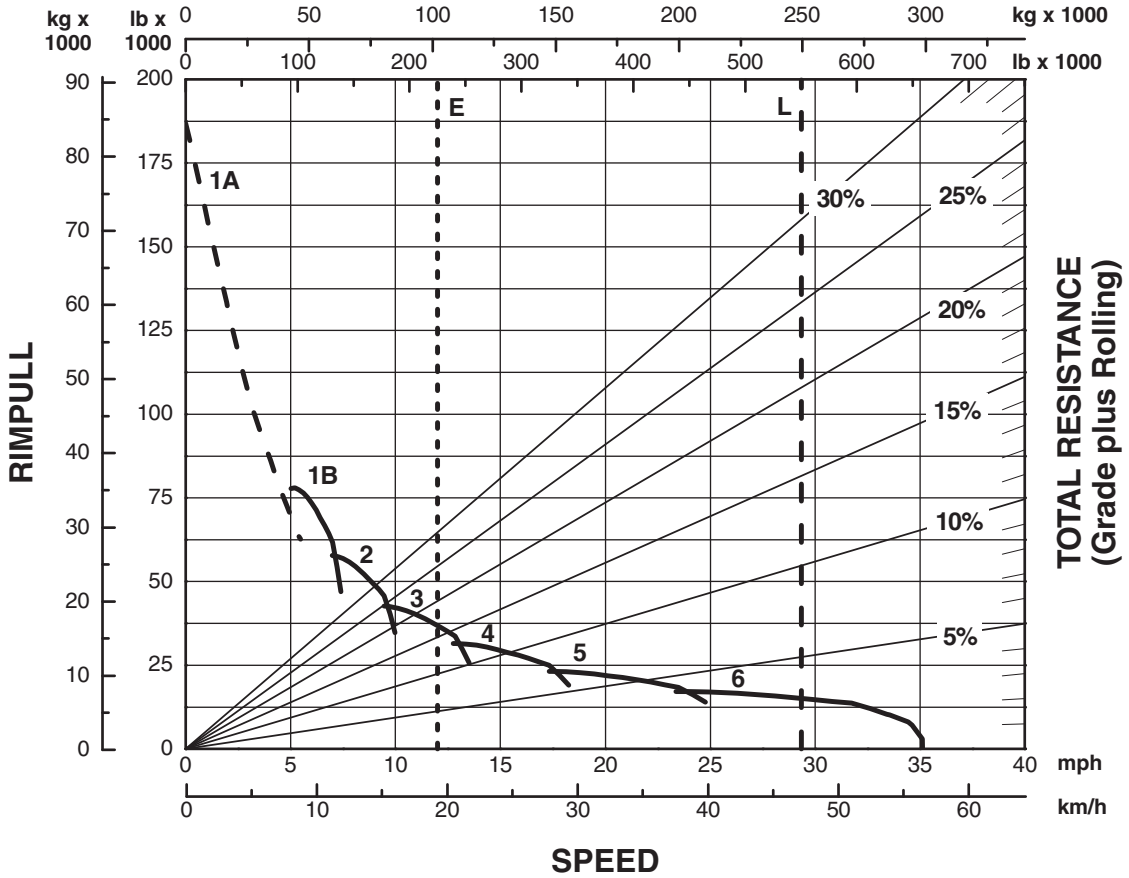

9

KEY

- 1A — 1st Gear (Torque Converter)
- 1B — 1st Gear
- 2 — 2nd Gear
- 3 — 3rd Gear
- 4 — 4th Gear
- 5 — 5th Gear
- 6 — 6th Gear

KEY

- E — Est. Max Field Empty Weight 115 085 kg (253,719 lb)
- L — Max GMW 249 475 kg (550,000 lb)

\*At Sea Level.

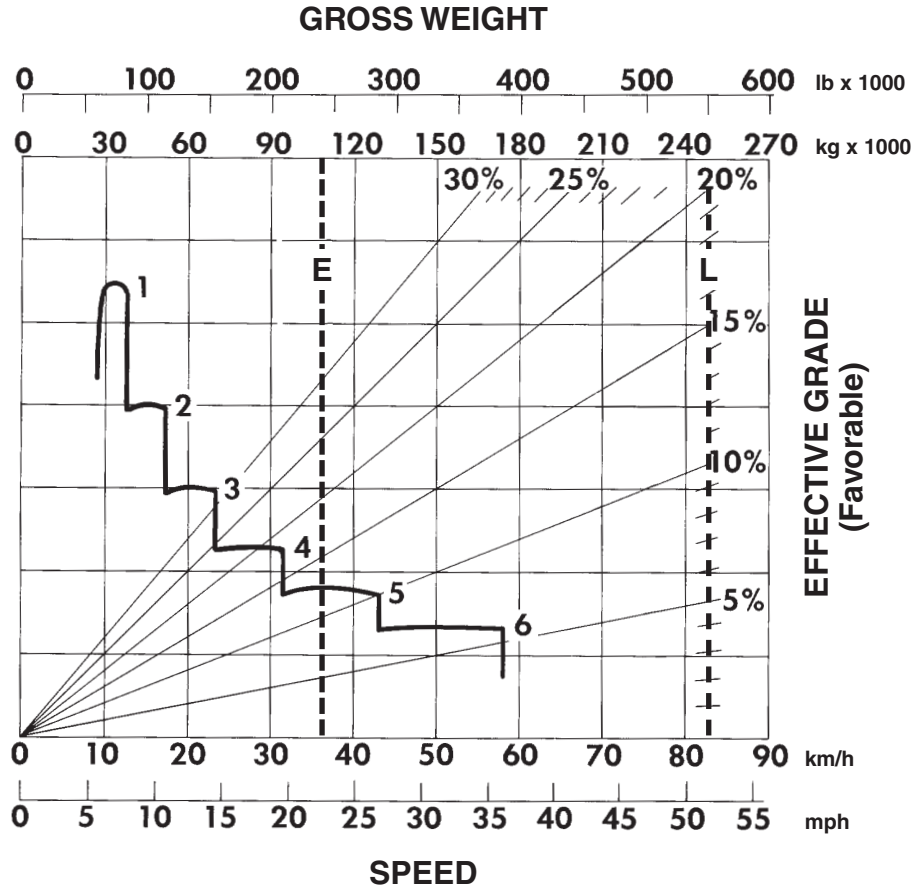

**CONTINUOUS GRADE LENGTH**

KEY

- 1 — 1st Gear
- 2 — 2nd Gear
- 3 — 3rd Gear
- 4 — 4th Gear
- 5 — 5th Gear
- 6 — 6th Gear

KEY

- E — Est. Field Empty Weight 107 190 kg (236,314 lb)
- L — Max GMW 249 433 kg (550,000 lb)

### 785C Brake Performance

- 450 m (1500 ft)    ● 600 m (2000 ft)
- 900 m (3000 ft)    ● 1500 m (5000 ft)

### Construction & Mining Trucks

#### GROSS WEIGHT

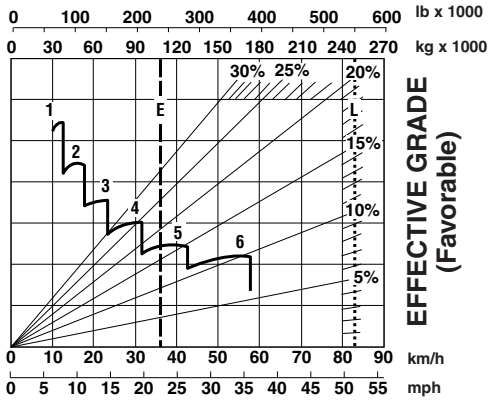

#### SPEED

GRADE DISTANCE — 450 m (1500 ft)

#### GROSS WEIGHT

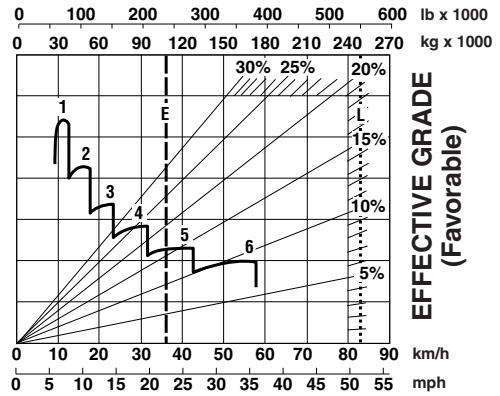

#### SPEED

GRADE DISTANCE — 600 m (2000 ft)

#### GROSS WEIGHT

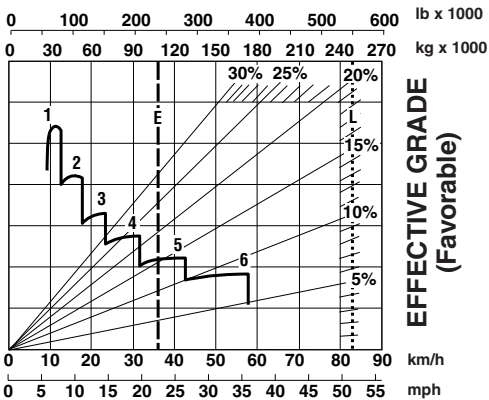

#### SPEED

GRADE DISTANCE — 900 m (3000 ft)

#### GROSS WEIGHT

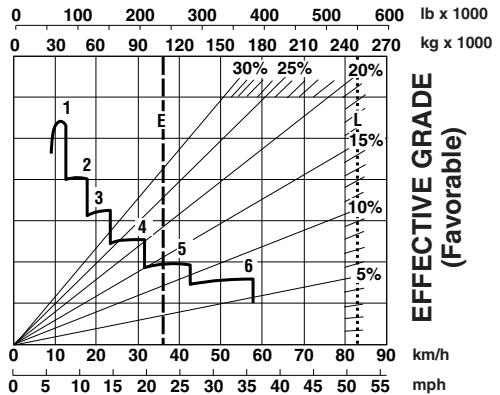

#### SPEED

GRADE DISTANCE — 1500 m (5000 ft)

#### KEY

- 1 — 1st Gear
- 2 — 2nd Gear
- 3 — 3rd Gear
- 4 — 4th Gear
- 5 — 5th Gear
- 6 — 6th Gear

#### KEY

- E — Est. Field Empty Weight 107 190 kg (236,314 lb)
- L — Max GMW 249 433 kg (550,000 lb)



**LOADED**

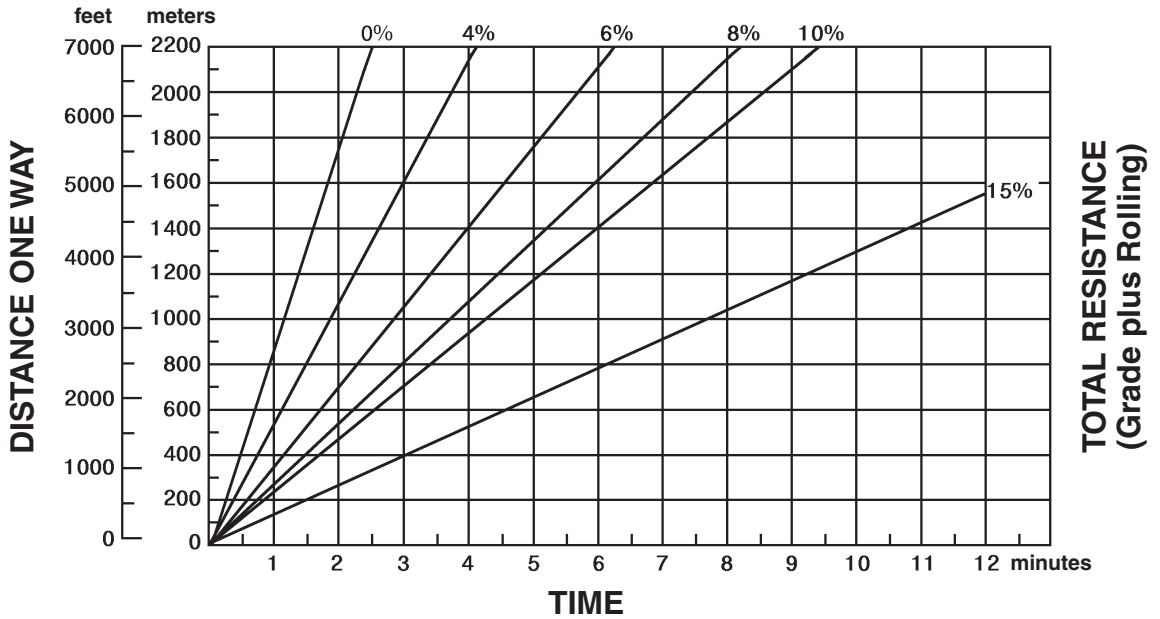

**EMPTY**

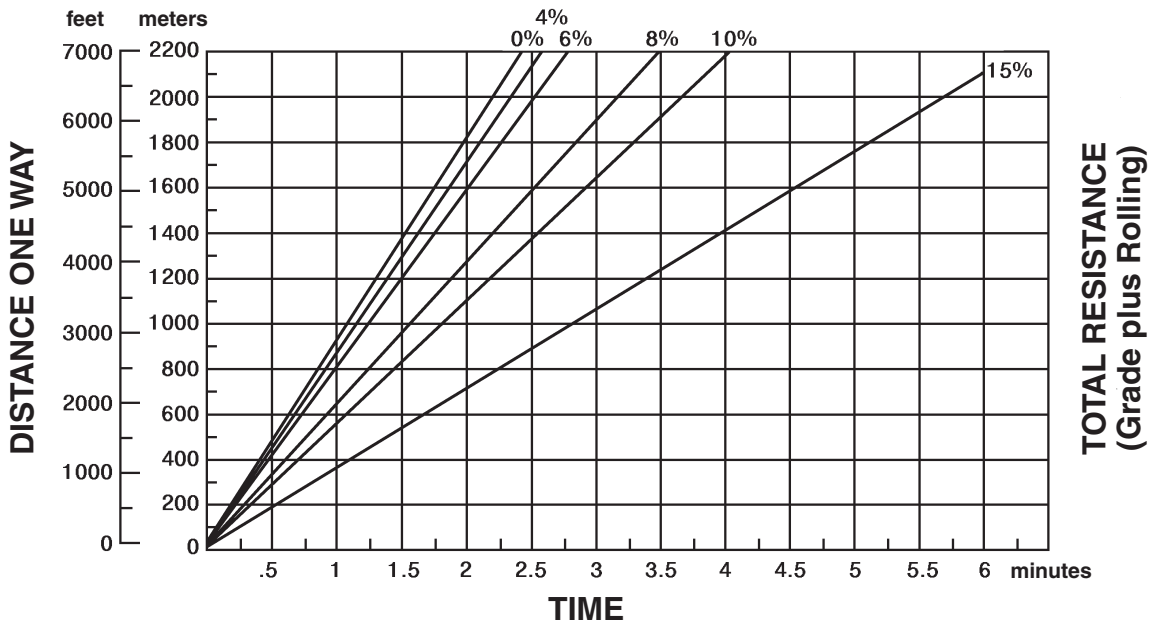

GROSS WEIGHT

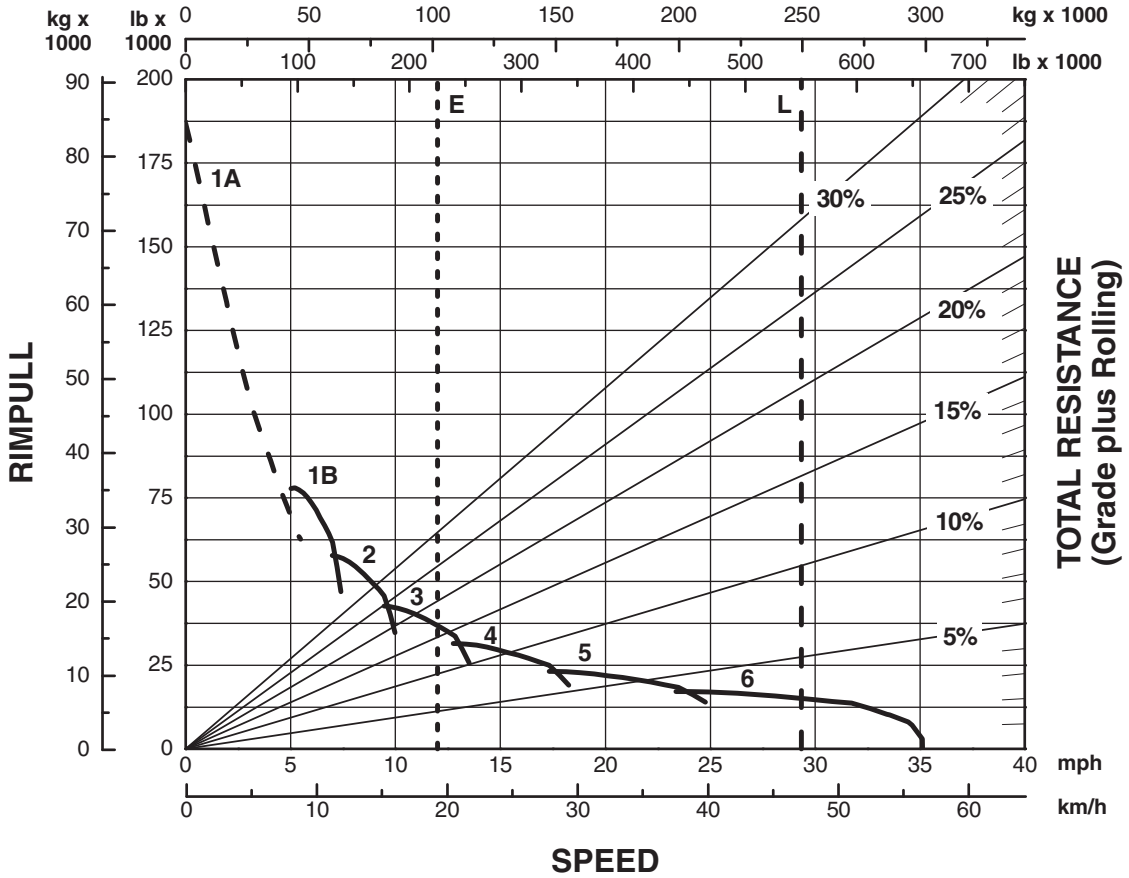

KEY

- 1A — 1st Gear (Torque Converter)
- 1B — 1st Gear
- 2 — 2nd Gear
- 3 — 3rd Gear
- 4 — 4th Gear
- 5 — 5th Gear
- 6 — 6th Gear

KEY

- E — Est. Max Field Empty Weight 116 505 kg (256,849 lb)
- L — Max GMW 249 475 kg (550,000 lb)

\*At Sea Level.

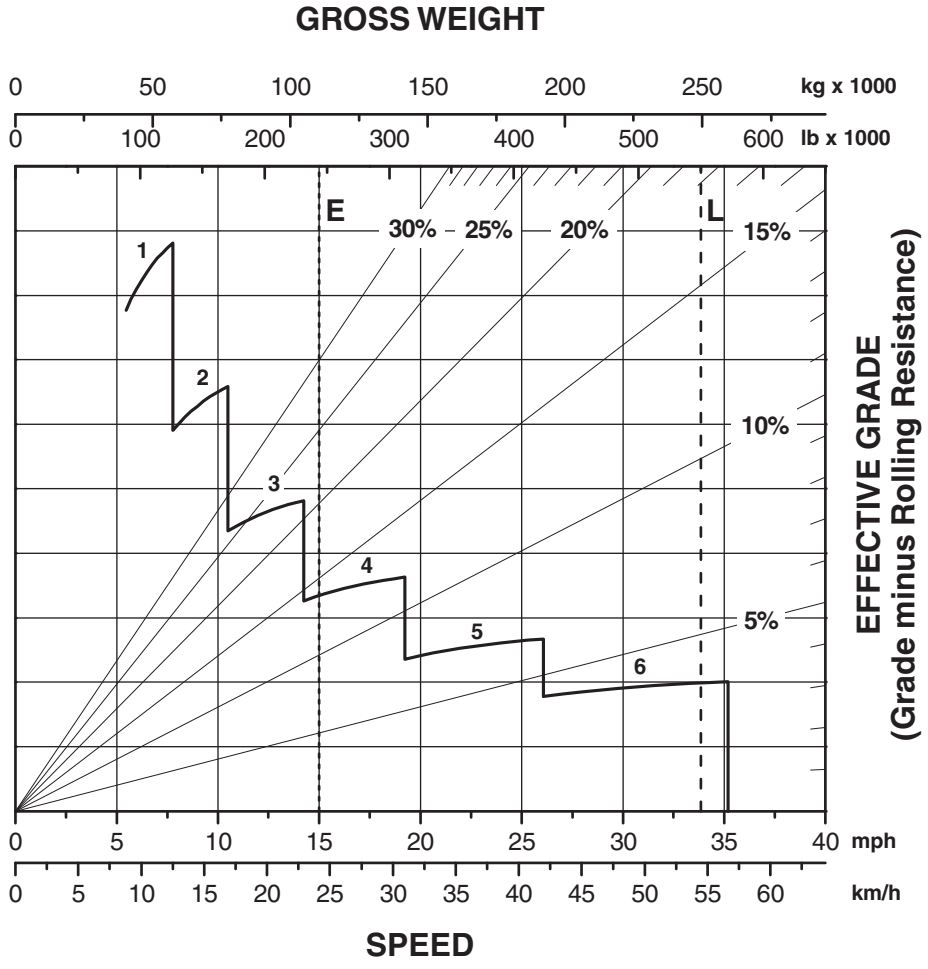

- KEY**
- 1 — 1st Gear
  - 2 — 2nd Gear
  - 3 — 3rd Gear
  - 4 — 4th Gear
  - 5 — 5th Gear
  - 6 — 6th Gear

- KEY**
- E — Est. Field Empty Weight 108 481 kg (239,160 lb)
  - L — Max GMW 249 433 kg (550,000 lb)

\*At Sea Level.

785D Brake Performance

- 450 m (1500 ft)
- 600 m (2000 ft)
- 900 m (3000 ft)
- 1500 m (5000 ft)

Construction & Mining Trucks

GROSS WEIGHT

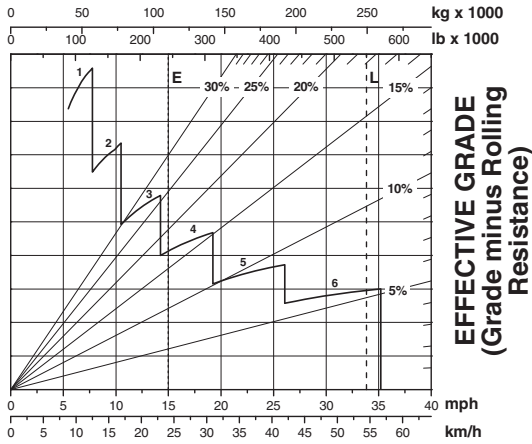

SPEED  
GRADE DISTANCE — 450 m (1500 ft)\*

GROSS WEIGHT

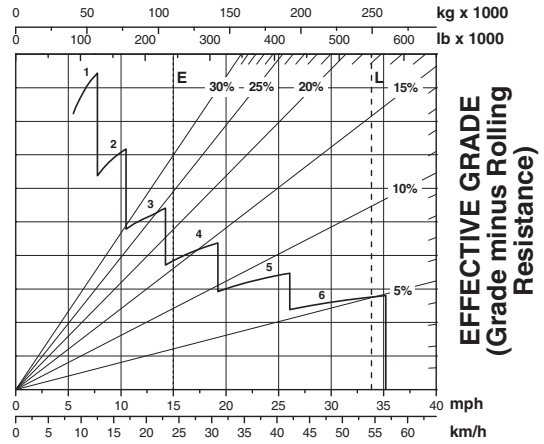

SPEED  
GRADE DISTANCE — 600 m (2000 ft)\*

GROSS WEIGHT

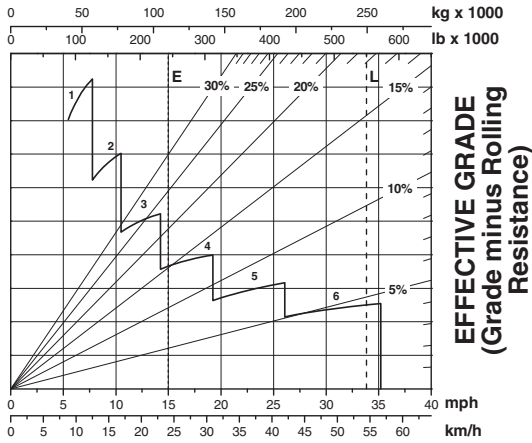

SPEED  
GRADE DISTANCE — 900 m (3000 ft)\*

GROSS WEIGHT

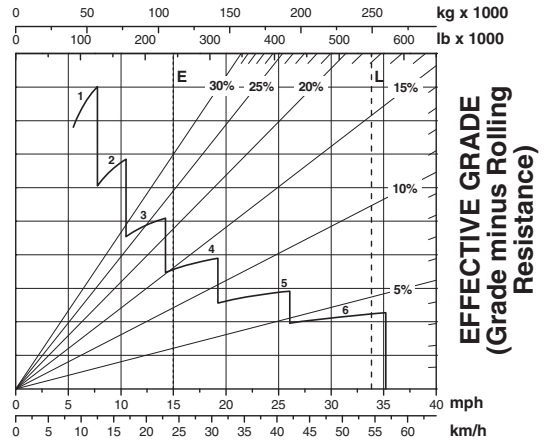

SPEED  
GRADE DISTANCE — 1500 m (5000 ft)\*

KEY

- 1 — 1st Gear
- 2 — 2nd Gear
- 3 — 3rd Gear
- 4 — 4th Gear
- 5 — 5th Gear
- 6 — 6th Gear

KEY

- E — Est. Field Empty Weight 108 481 kg (239,160 lb)
- L — Max GMW 249 433 kg (550,000 lb)

\*At Sea Level.

**LOADED**

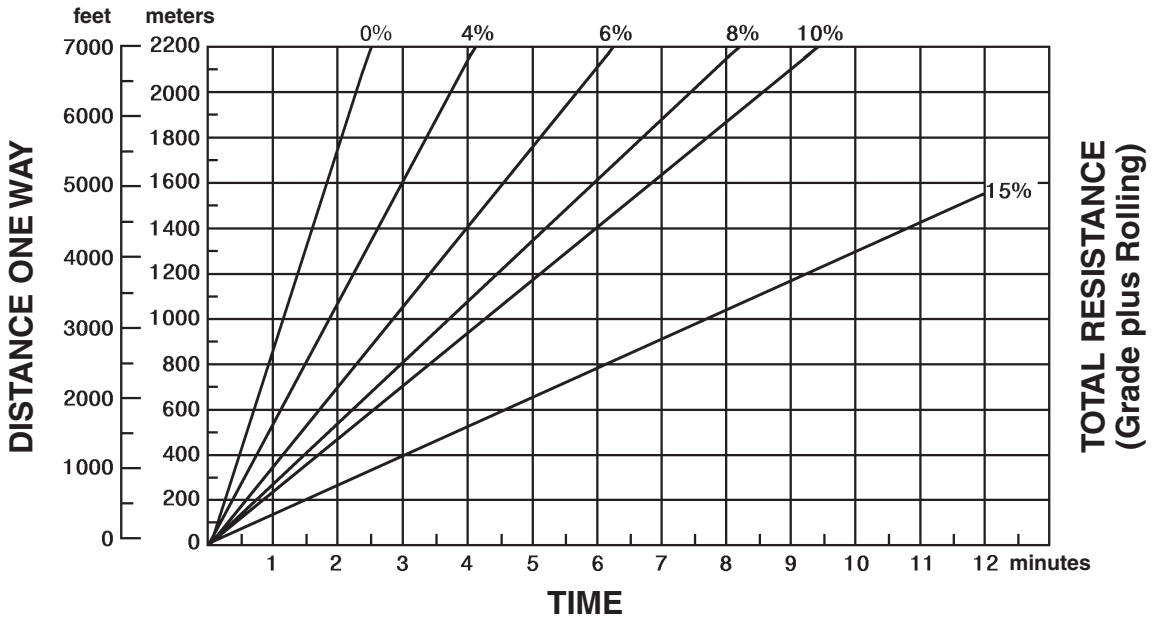

**EMPTY**

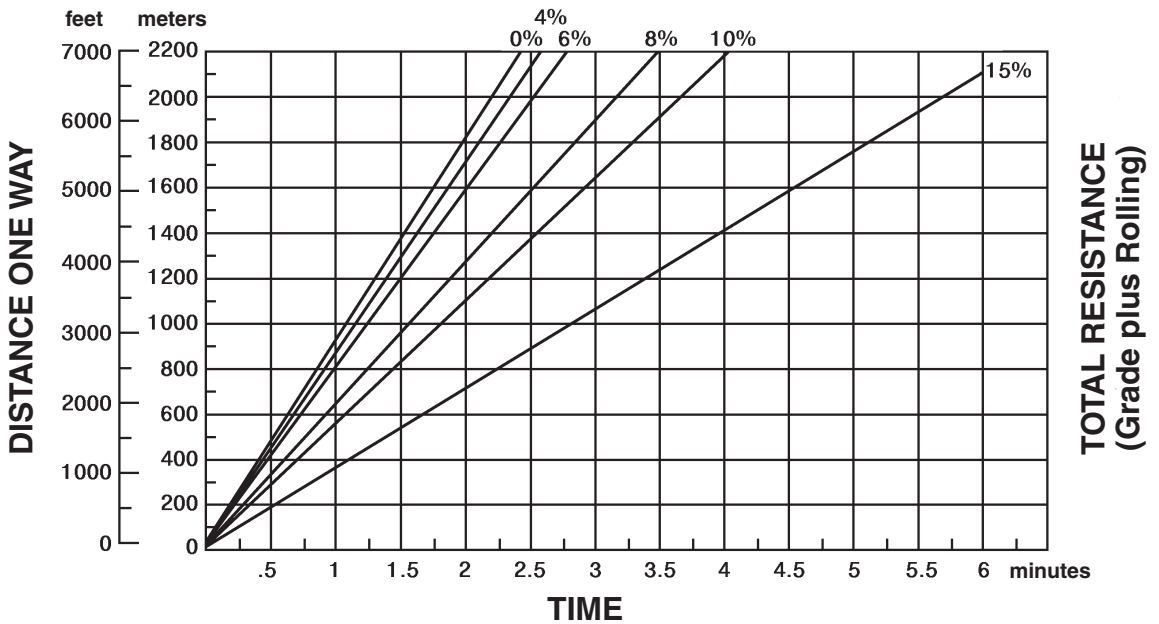

789C Rimpull-Speed-Gradeability  
 ● 37.00R57 Tires\*\*  
 ● 1593 mm (5'2.7") Tire Radius

Construction & Mining Trucks

**GROSS WEIGHT**

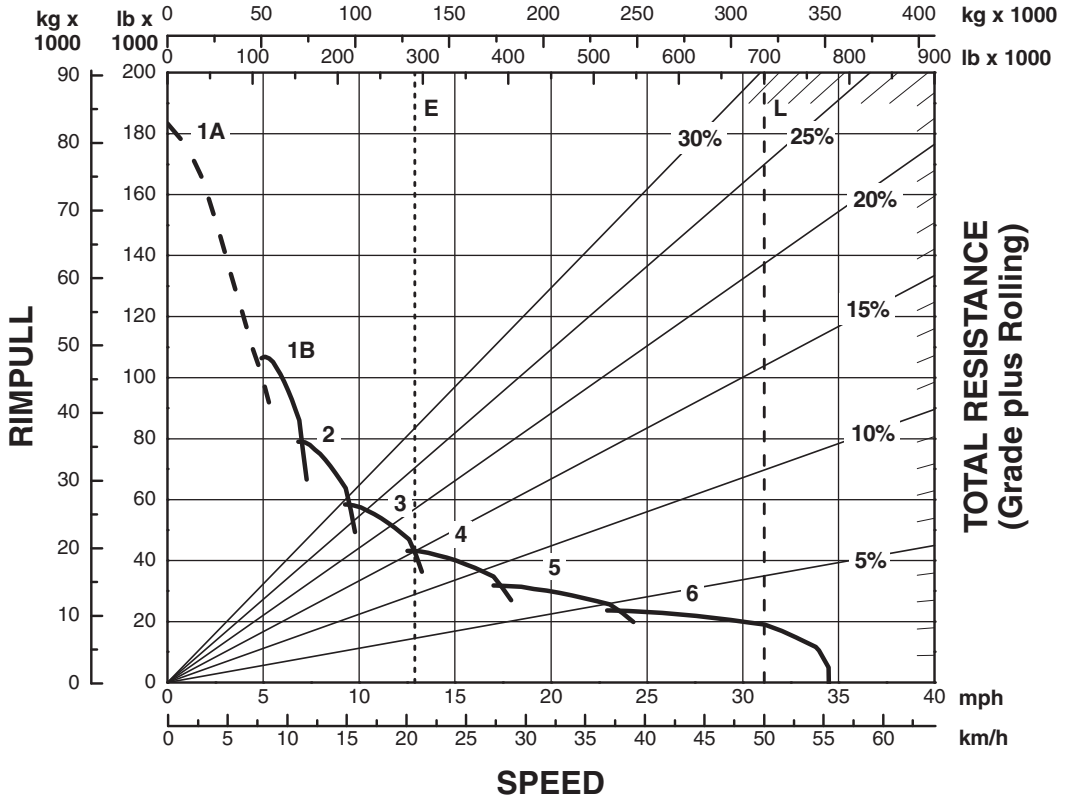

9

**KEY**

- 1A — 1st Gear (Torque Converter)
- 1B — 1st Gear
- 2 — 2nd Gear
- 3 — 3rd Gear
- 4 — 4th Gear
- 5 — 5th Gear
- 6 — 6th Gear

**KEY**

- E — Est. Max Field Empty Weight 132 651 kg (292,447 lb)\*
- L — Max GMW 317 460 kg (700,000 lb)

\*Truck equipped with sideboards and liners.  
 \*\*At Sea Level.

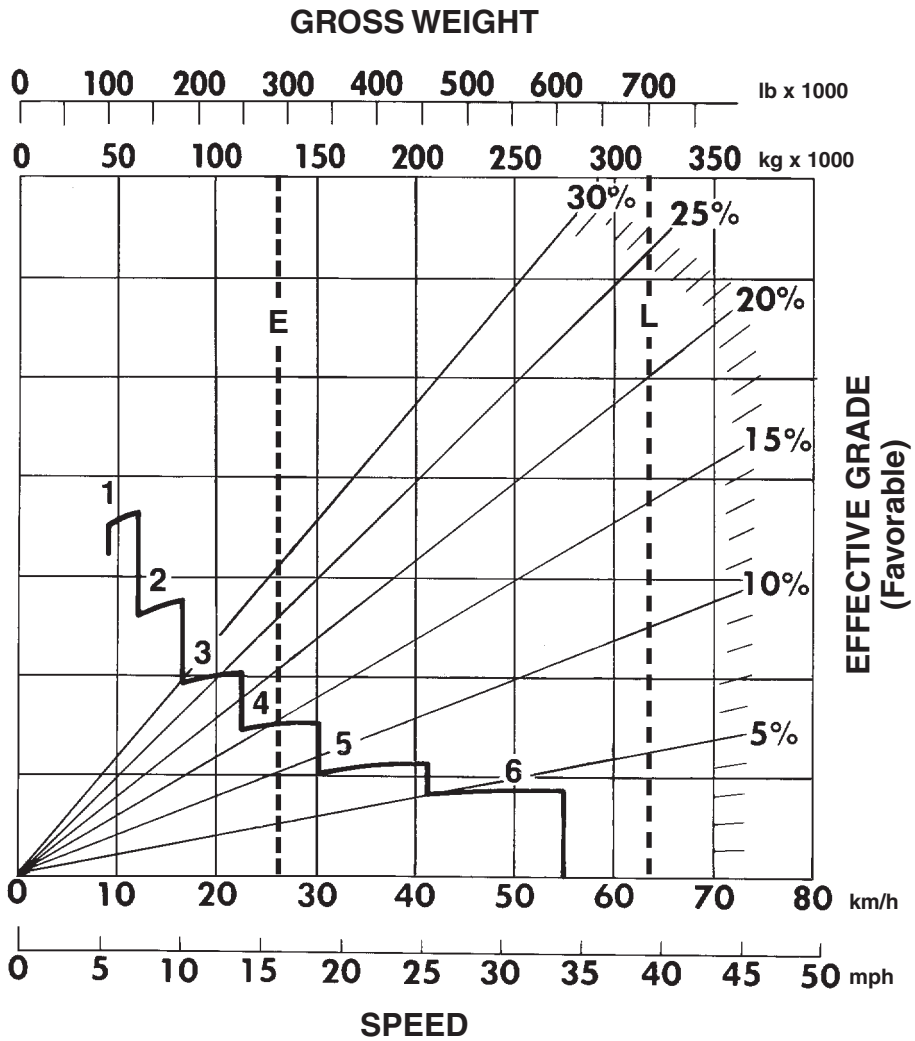

**KEY**

- 1 — 1st Gear
- 2 — 2nd Gear
- 3 — 3rd Gear
- 4 — 4th Gear
- 5 — 5th Gear
- 6 — 6th Gear

**KEY**

- E — Est. Field Empty Weight 132 651 kg (292,447 lb)\*
- L — Max GMW 317 460 kg (700,000 lb)

\*Truck equipped with sideboards and liners.

789C Brake Performance

- 450 m (1500 ft)
- 600 m (2000 ft)
- 900 m (3000 ft)
- 1500 m (5000 ft)

Construction & Mining Trucks

GROSS WEIGHT

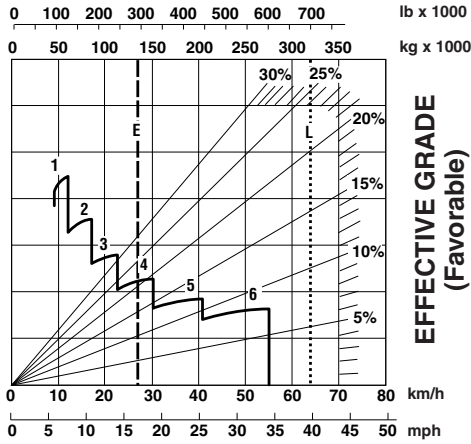

GRADE DISTANCE — 450 m (1500 ft)

GROSS WEIGHT

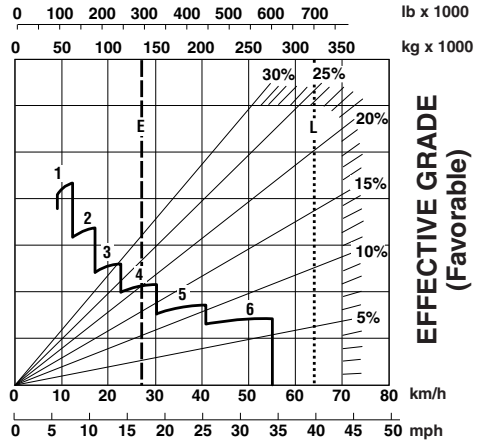

GRADE DISTANCE — 600 m (2000 ft)

GROSS WEIGHT

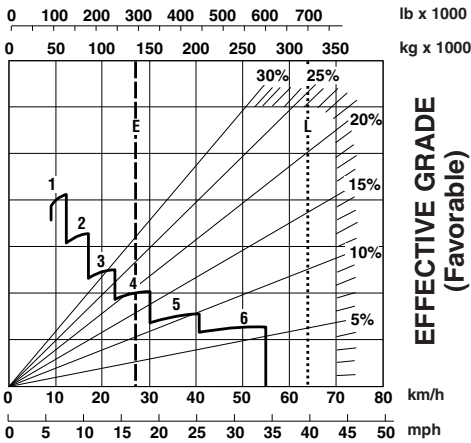

GRADE DISTANCE — 900 m (3000 ft)

GROSS WEIGHT

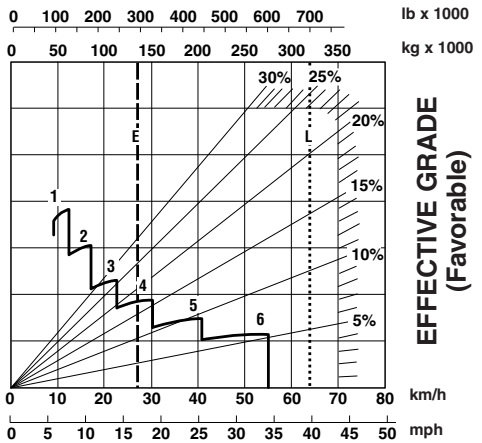

GRADE DISTANCE — 1500 m (5000 ft)

KEY

- 1 — 1st Gear
- 2 — 2nd Gear
- 3 — 3rd Gear
- 4 — 4th Gear
- 5 — 5th Gear
- 6 — 6th Gear

KEY

- E — Est. Field Empty Weight 132 651 kg (292,447 lb)\*
- L — Max GMW 317 460 kg (700,000 lb)

\*Truck equipped with sideboards and liners.



**LOADED**

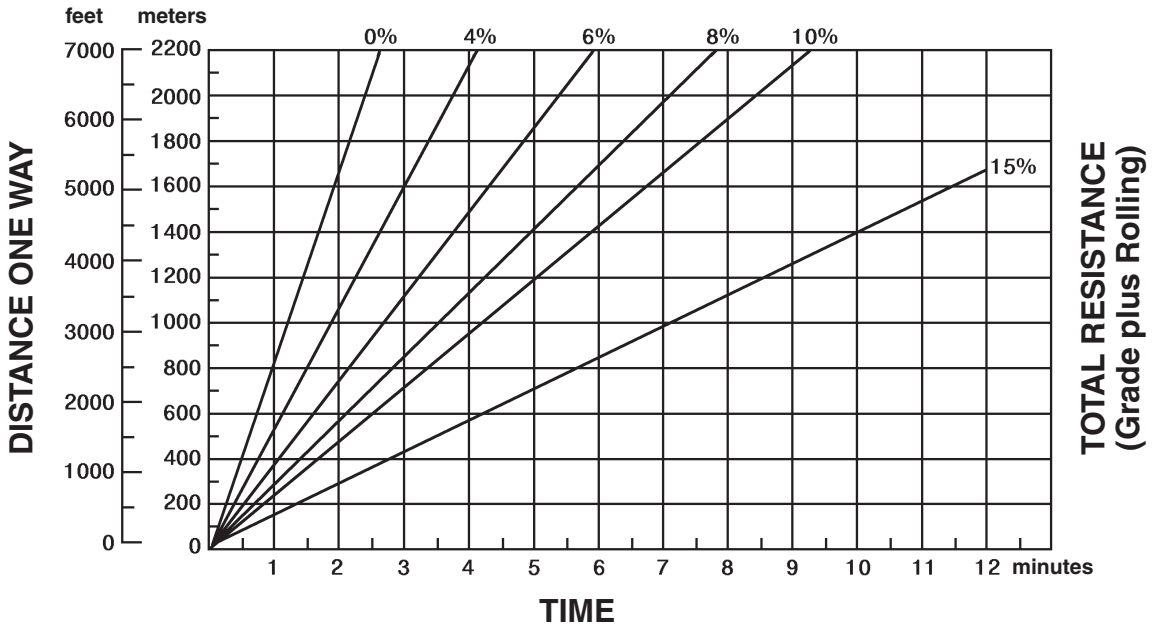

**EMPTY**

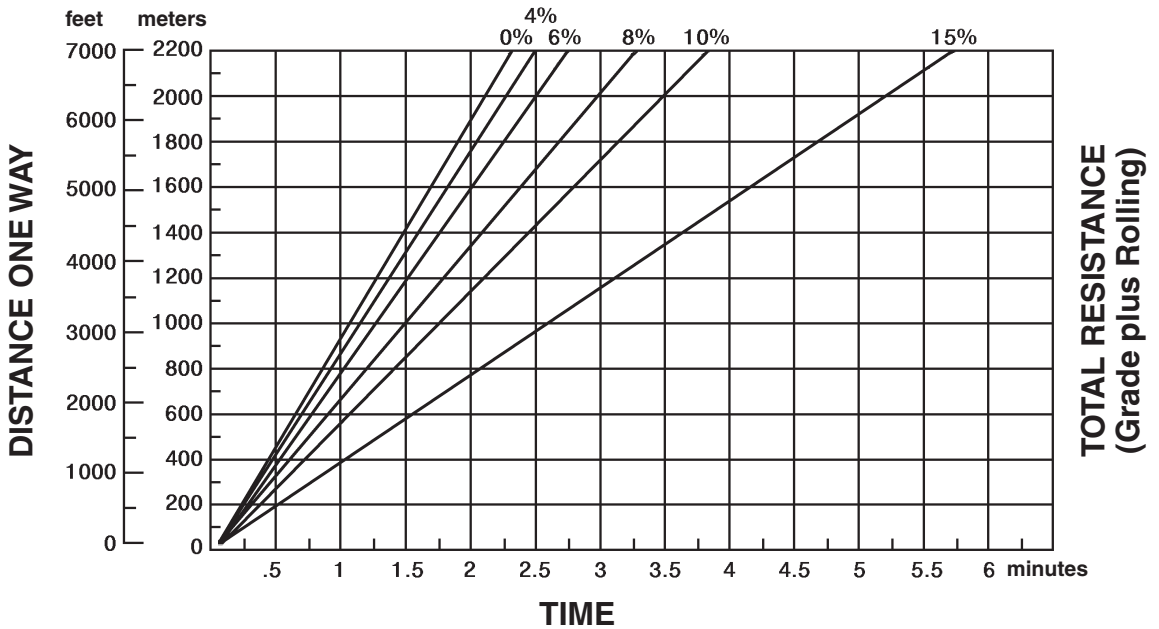

793D Rimpull-Speed-Gradeability  
 ● Standard Arrangement\*\*  
 ● 40.00R57 Tires  
 ● 1778 mm (5'10") Tire Radius

Construction & Mining Trucks

GROSS WEIGHT

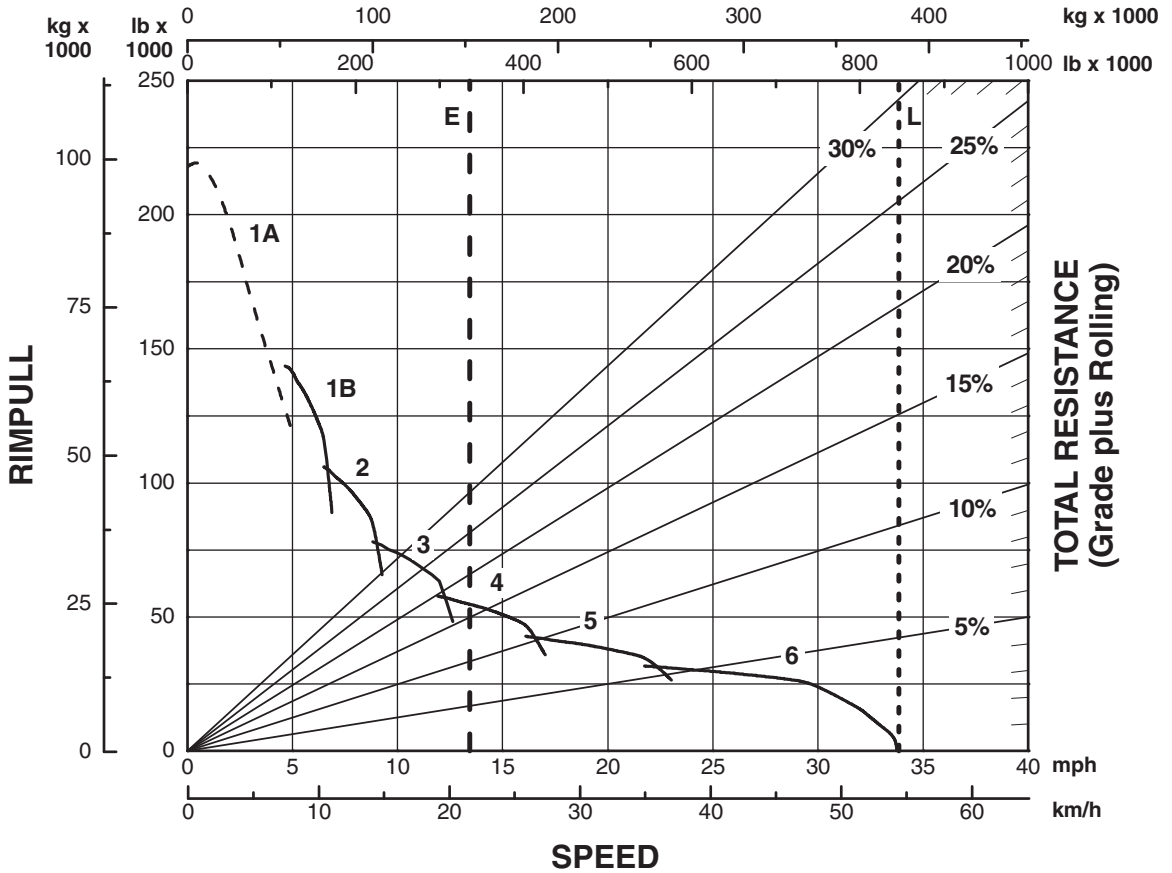

9

KEY

- 1A — 1st Gear (Torque Converter)
- 1B — 1st Gear
- 2 — 2nd Gear
- 3 — 3rd Gear
- 4 — 4th Gear
- 5 — 5th Gear
- 6 — 6th Gear

KEY

- E — Est. Max Field Empty Weight 156 470 kg (344,960 lb)\*
- L — Max GMW 383 740 kg (846,000 lb)

\*Truck equipped with sideboards and liners.  
 \*\*At Sea Level.

# Construction & Mining Trucks

## 793D Rimpull-Speed-Gradeability

- High Speed Arrangement\*\*
- 40.00R57 Tires
- 1778 mm (5'10") Tire Radius

### GROSS WEIGHT

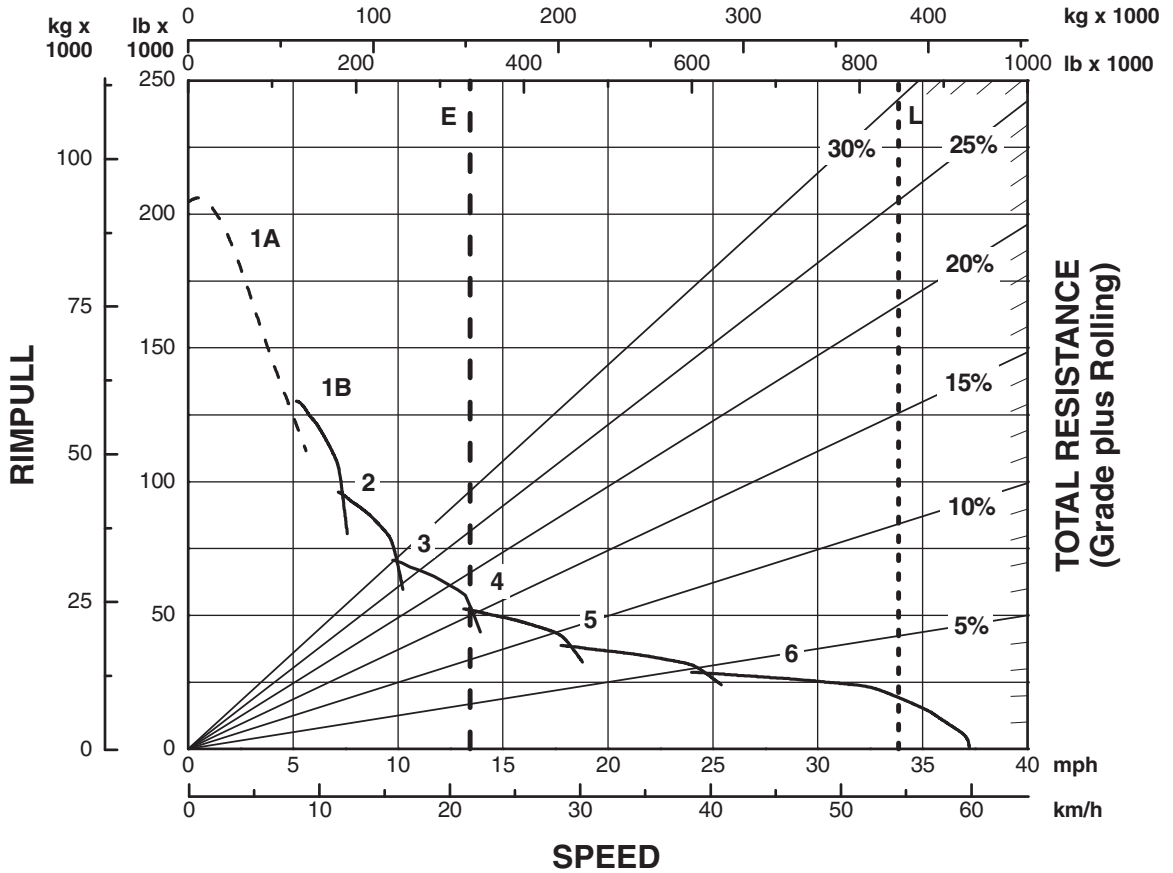

#### KEY

- 1A — 1st Gear (Torque Converter)
- 1B — 1st Gear
- 2 — 2nd Gear
- 3 — 3rd Gear
- 4 — 4th Gear
- 5 — 5th Gear
- 6 — 6th Gear

#### KEY

- E — Est. Max Field Empty Weight 156 470 kg (344,960 lb)\*
- L — Max GMW 383 740 kg (846,000 lb)

\*Truck equipped with sideboards and liners.  
\*\*At Sea Level.

793D Rimpull-Speed-Gradeability  
 ● High Altitude Arrangement\*\*  
 ● 40.00R57 Tires  
 ● 1778 mm (5'10") Tire Radius

Construction & Mining Trucks

GROSS WEIGHT

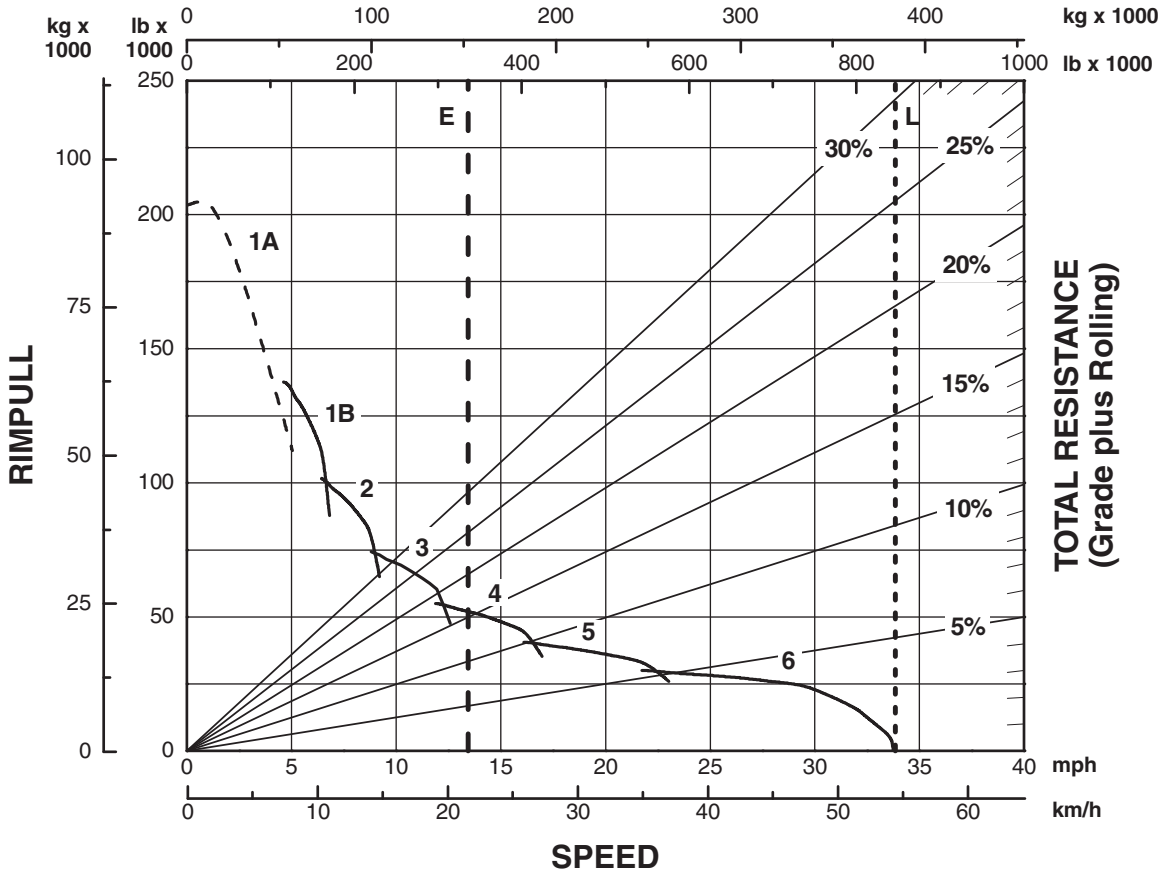

9

KEY

- 1A — 1st Gear (Torque Converter)
- 1B — 1st Gear
- 2 — 2nd Gear
- 3 — 3rd Gear
- 4 — 4th Gear
- 5 — 5th Gear
- 6 — 6th Gear

KEY

- E — Est. Max Field Empty Weight 156 470 kg (344,960 lb)\*
- L — Max GMW 383 740 kg (846,000 lb)

\*Truck equipped with sideboards and liners.  
 \*\*At Sea Level.

- Standard Arrangement\*\*
- Continuous Grade Retarding

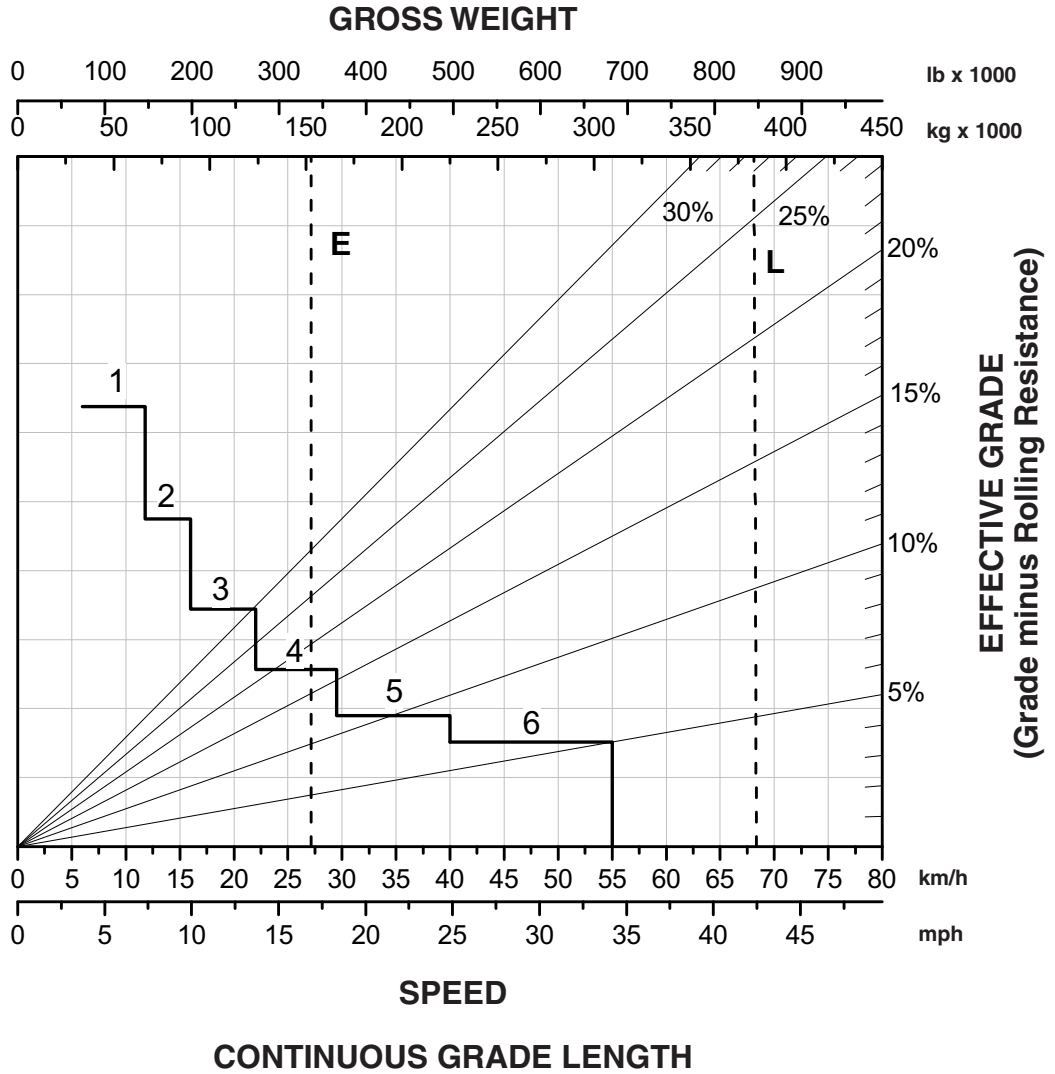

**KEY**

- 1 — 1st Gear
- 2 — 2nd Gear
- 3 — 3rd Gear
- 4 — 4th Gear
- 5 — 5th Gear
- 6 — 6th Gear

**KEY**

- E — Est. Field Empty Weight 156 470 kg (344,960 lb)\*
- L — Max GMW 383 740 kg (846,000 lb)

\*Truck equipped with sideboards and liners.  
 \*\*At Sea Level.

## 793D Brake Performance

• Standard Arrangement\*\*

- 450 m (1500 ft)    • 600 m (2000 ft)
- 900 m (3000 ft)    • 1500 m (5000 ft)

## Construction & Mining Trucks

### GROSS WEIGHT

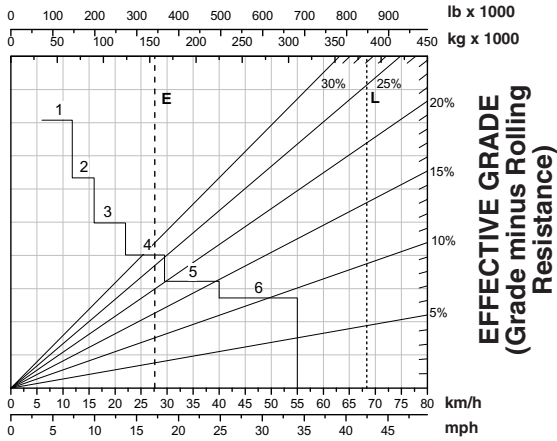

**SPEED**  
GRADE DISTANCE — 450 m (1500 ft)

### GROSS WEIGHT

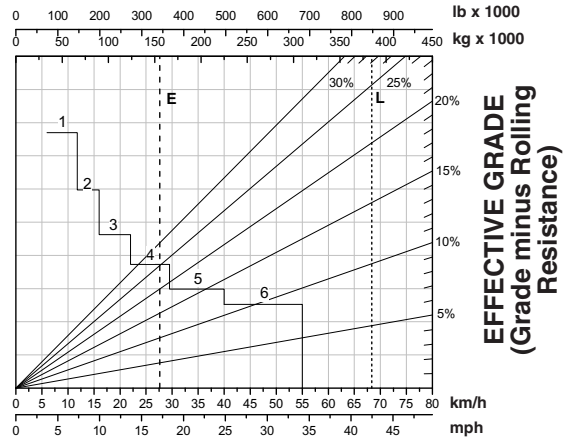

**SPEED**  
GRADE DISTANCE — 600 m (2000 ft)

### GROSS WEIGHT

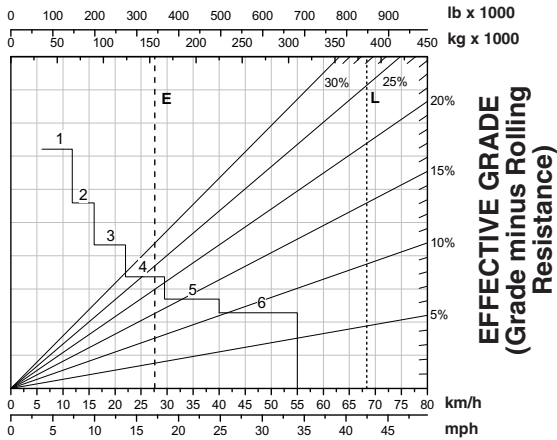

**SPEED**  
GRADE DISTANCE — 900 m (3000 ft)

### GROSS WEIGHT

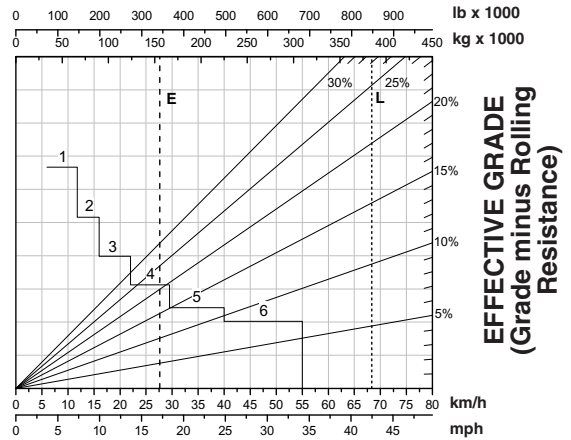

**SPEED**  
GRADE DISTANCE — 1500 m (5000 ft)

#### KEY

- 1 — 1st Gear
- 2 — 2nd Gear
- 3 — 3rd Gear
- 4 — 4th Gear
- 5 — 5th Gear
- 6 — 6th Gear

#### KEY

- E — Est. Field Empty Weight 156 470 kg (344,960 lb)\*
- L — Max GMW 383 740 kg (846,000 lb)

\*Truck equipped with sideboards and liners.  
\*\*At Sea Level.

- Additional Retarding Arrangement\*\*
- Continuous Grade Retarding

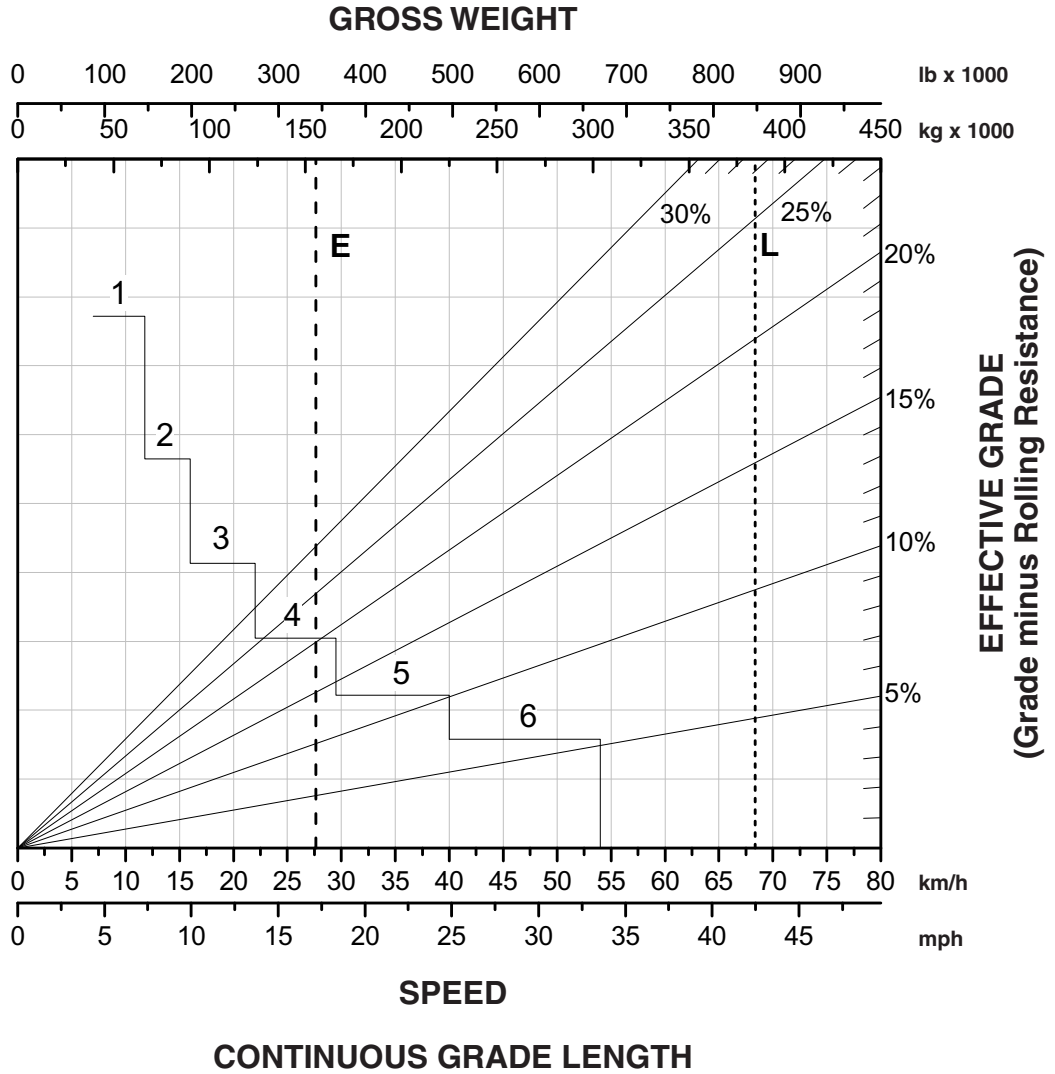

**KEY**

- 1 — 1st Gear
- 2 — 2nd Gear
- 3 — 3rd Gear
- 4 — 4th Gear
- 5 — 5th Gear
- 6 — 6th Gear

**KEY**

- E — Est. Field Empty Weight 156 470 kg (344,960 lb)\*
- L — Max GMW 383 740 kg (846,000 lb)

\*Truck equipped with sideboards and liners.  
\*\*At Sea Level.

## 793D Brake Performance

- Additional Retarding Arrangement\*\*
- 450 m (1500 ft) ● 600 m (2000 ft)
- 900 m (3000 ft) ● 1500 m (5000 ft)

## Construction & Mining Trucks

### GROSS WEIGHT

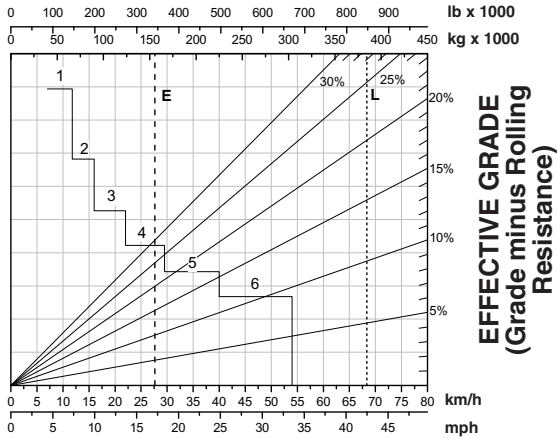

**SPEED**  
GRADE DISTANCE — 450 m (1500 ft)

### GROSS WEIGHT

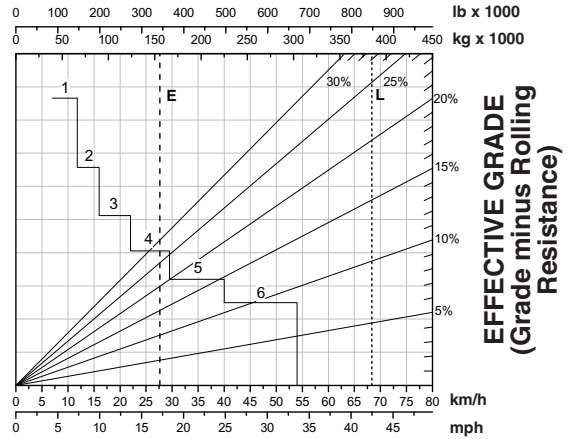

**SPEED**  
GRADE DISTANCE — 600 m (2000 ft)

### GROSS WEIGHT

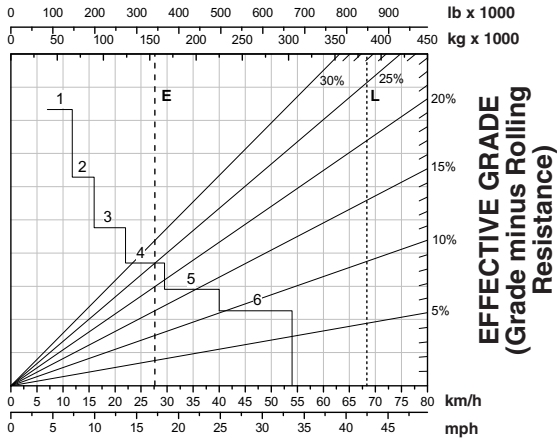

**SPEED**  
GRADE DISTANCE — 900 m (3000 ft)

### GROSS WEIGHT

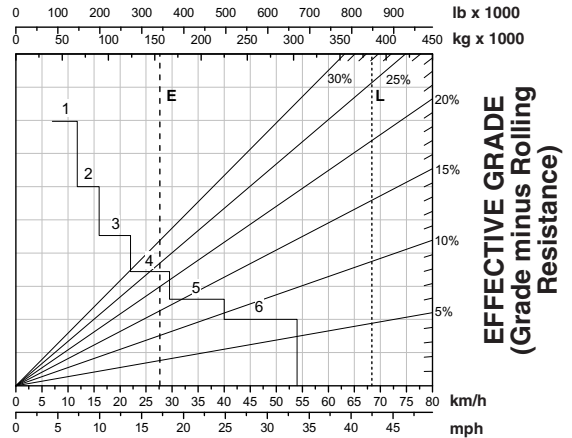

**SPEED**  
GRADE DISTANCE — 1500 m (5000 ft)

#### KEY

- 1 — 1st Gear
- 2 — 2nd Gear
- 3 — 3rd Gear
- 4 — 4th Gear
- 5 — 5th Gear
- 6 — 6th Gear

#### KEY

- E — Est. Field Empty Weight 156 470 kg (344,960 lb)\*
- L — Max GMW 383 740 kg (846,000 lb)

\*Truck equipped with sideboards and liners.  
\*\*At Sea Level.



# Construction & Mining Trucks

- 793D Travel Time
- Standard Arrangement
- 40.00R57 Tires

## LOADED

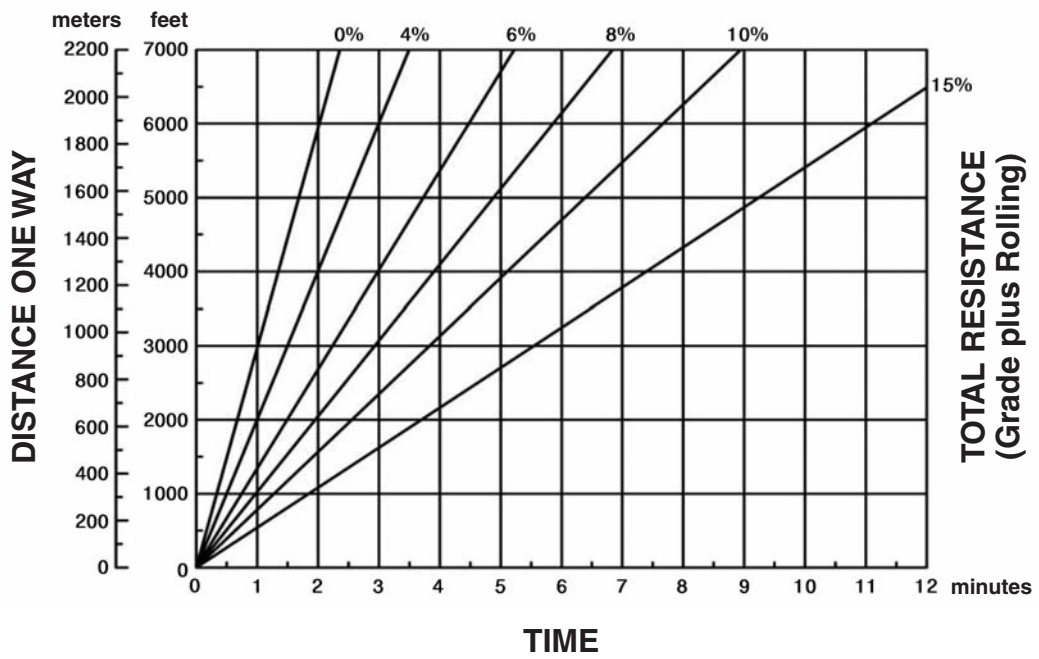

## EMPTY

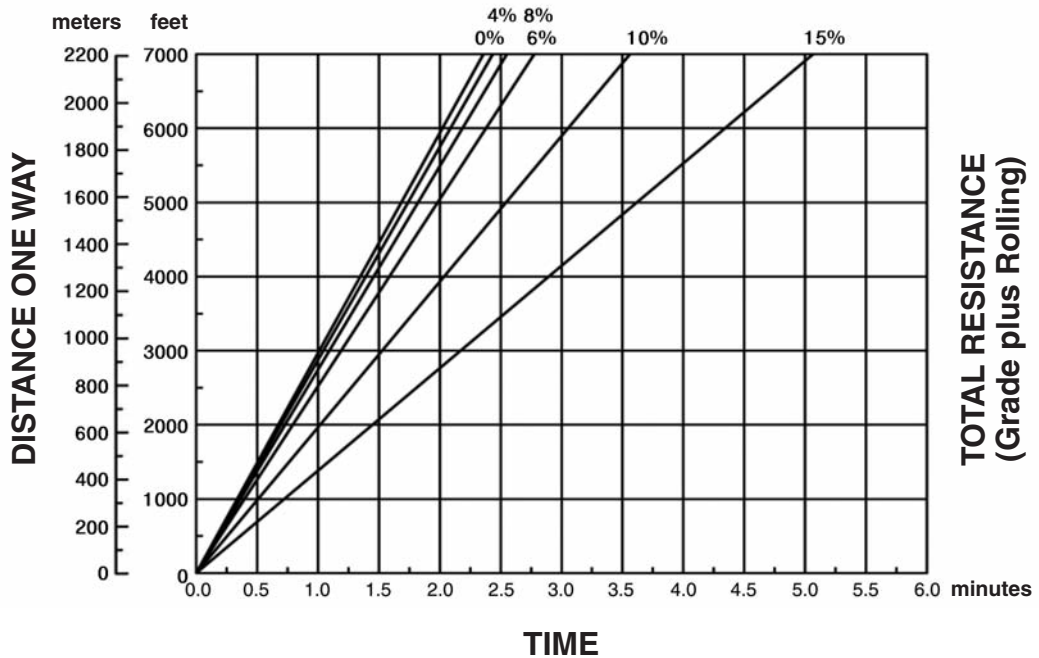

- 793D Travel Time
- Extra Top Speed Arrangement
- 40.00R57 Tires

**LOADED**

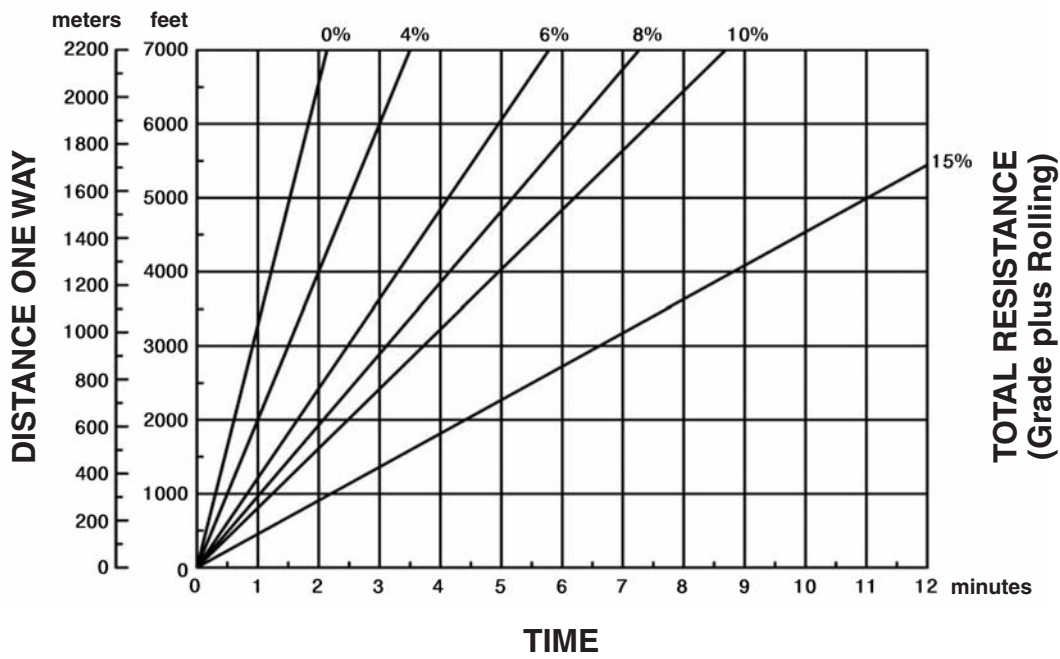

**EMPTY**

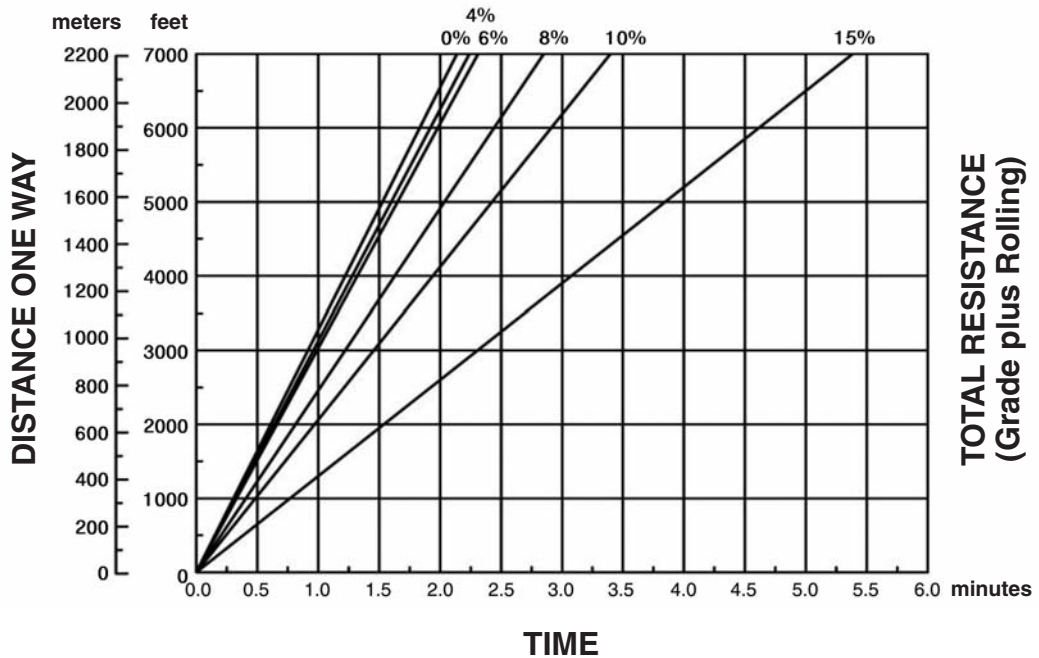

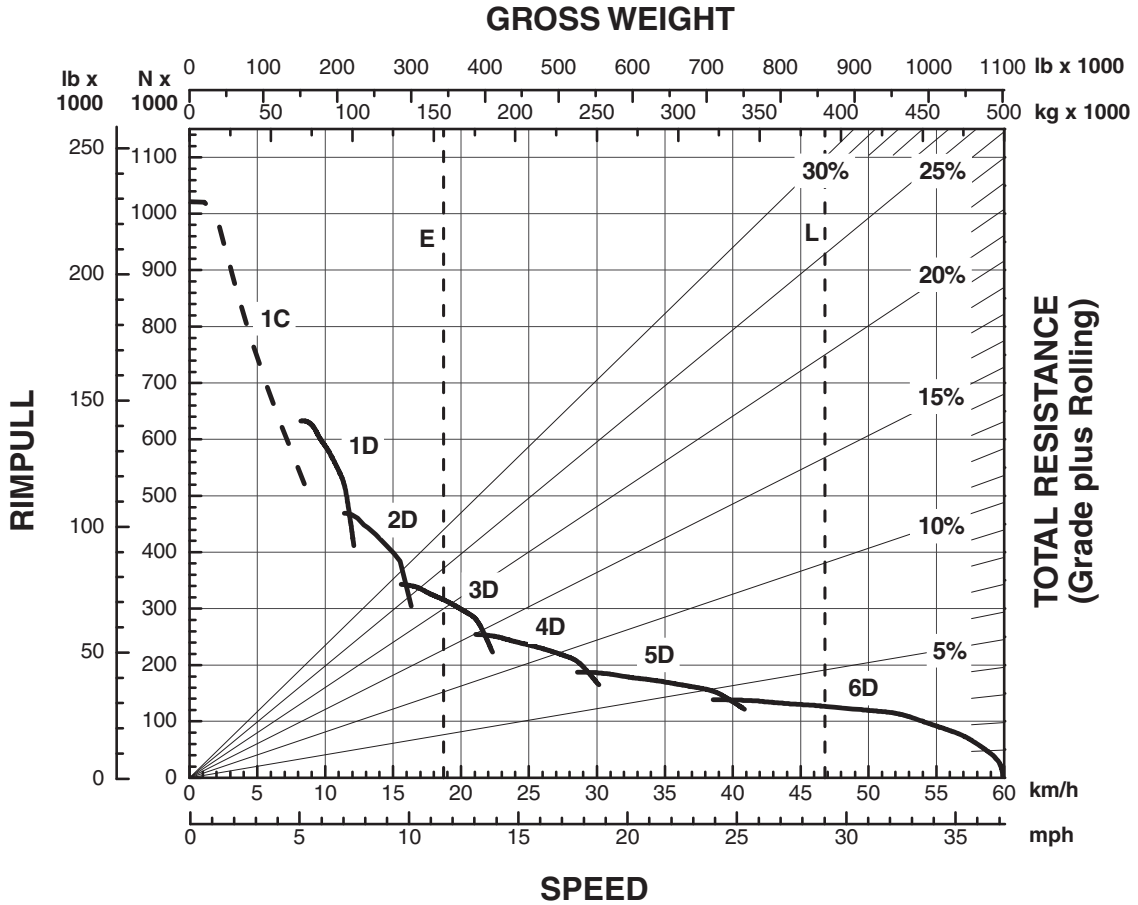

**KEY**

- 1 — 1st Gear
- 2 — 2nd Gear
- 3 — 3rd Gear
- 4 — 4th Gear
- 5 — 5th Gear
- 6 — 6th Gear

**KEY**

- E — Empty
- L — Loaded

\*At Sea Level.

- Typical Field Empty Weight
- ..... Gross Machine Operating Weight  
390 089 kg (860,000 lb)

- Torque Converter Drive
- Direct Drive

# 793F Brake Performance

- Standard Retarding
- Continuous Grade Retarding\*

# Construction & Mining Trucks

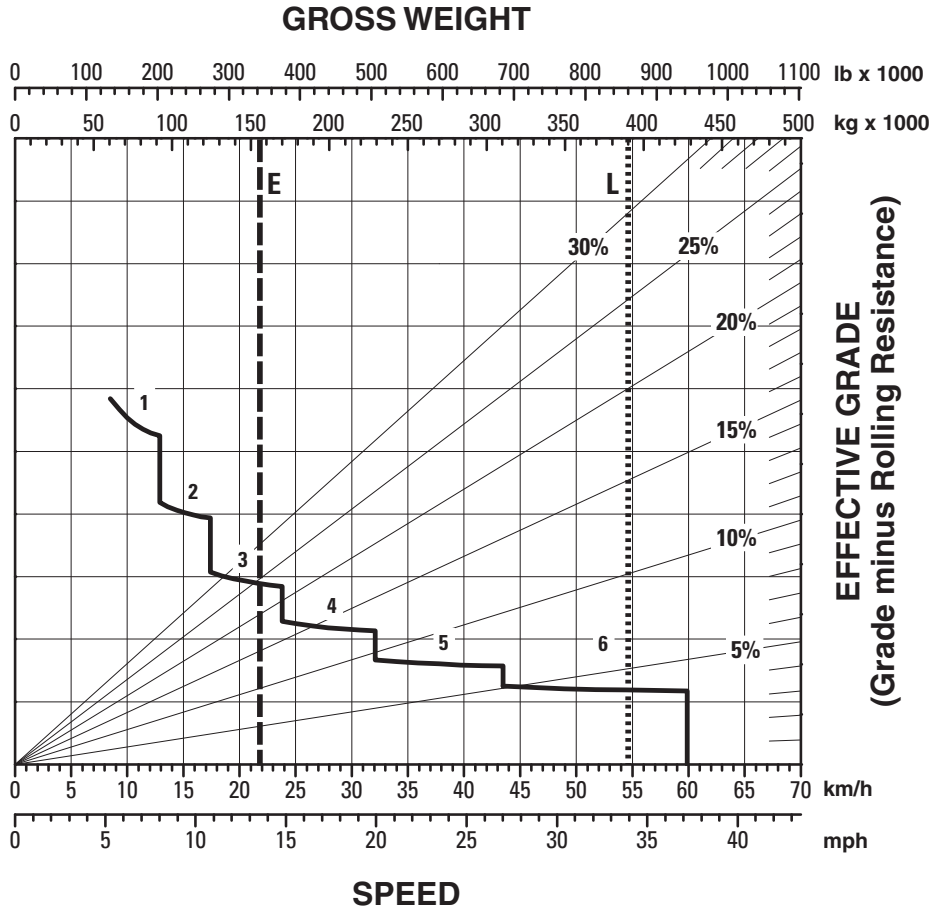

## CONTINUOUS GRADE LENGTH

### KEY

- 1 — 1st Gear
- 2 — 2nd Gear
- 3 — 3rd Gear
- 4 — 4th Gear
- 5 — 5th Gear
- 6 — 6th Gear

### KEY

- E — Empty
- L — Loaded

\*At Sea Level.

- Typical Field Empty Weight
- ..... Gross Machine Operating Weight  
390 089 kg (860,000 lb)

# Construction & Mining Trucks

## 793F Brake Performance

- Standard Retarding
- 450 m (1500 ft)    ● 600 m (2000 ft)
- 900 m (3000 ft)    ● 1500 m (5000 ft)

### GROSS WEIGHT

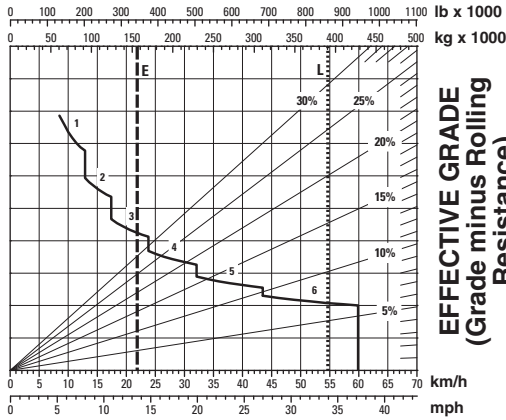

### SPEED

GRADE DISTANCE — 450 m (1500 ft)\*

### GROSS WEIGHT

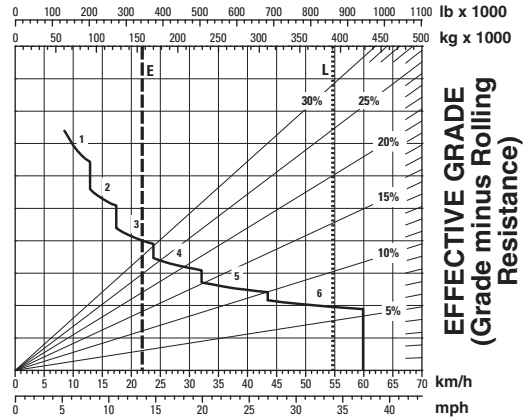

### SPEED

GRADE DISTANCE — 600 m (2000 ft)\*

### GROSS WEIGHT

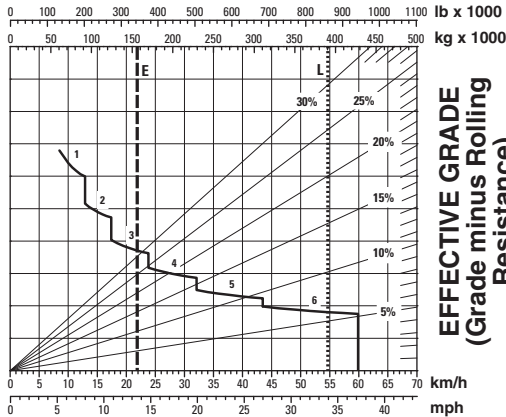

### SPEED

GRADE DISTANCE — 900 m (3000 ft)\*

### GROSS WEIGHT

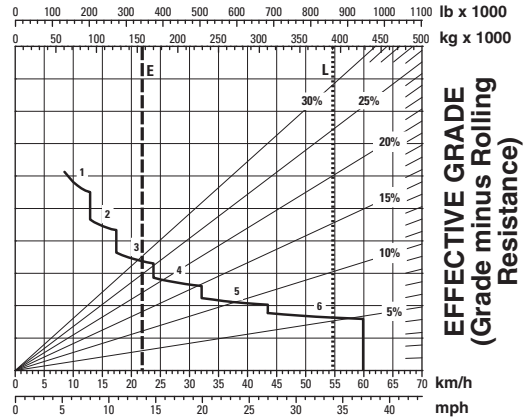

### SPEED

GRADE DISTANCE — 1500 m (5000 ft)\*

#### KEY

- 1 — 1st Gear
- 2 — 2nd Gear
- 3 — 3rd Gear
- 4 — 4th Gear
- 5 — 5th Gear
- 6 — 6th Gear

- Typical Field Empty Weight
- ..... Gross Machine Operating Weight 390 089 kg (860,000 lb)

#### KEY

- E — Empty
- L — Loaded

\*At Sea Level.

# 793F Brake Performance

- Additional Retarding
- Continuous Grade Retarding\*

# Construction & Mining Trucks

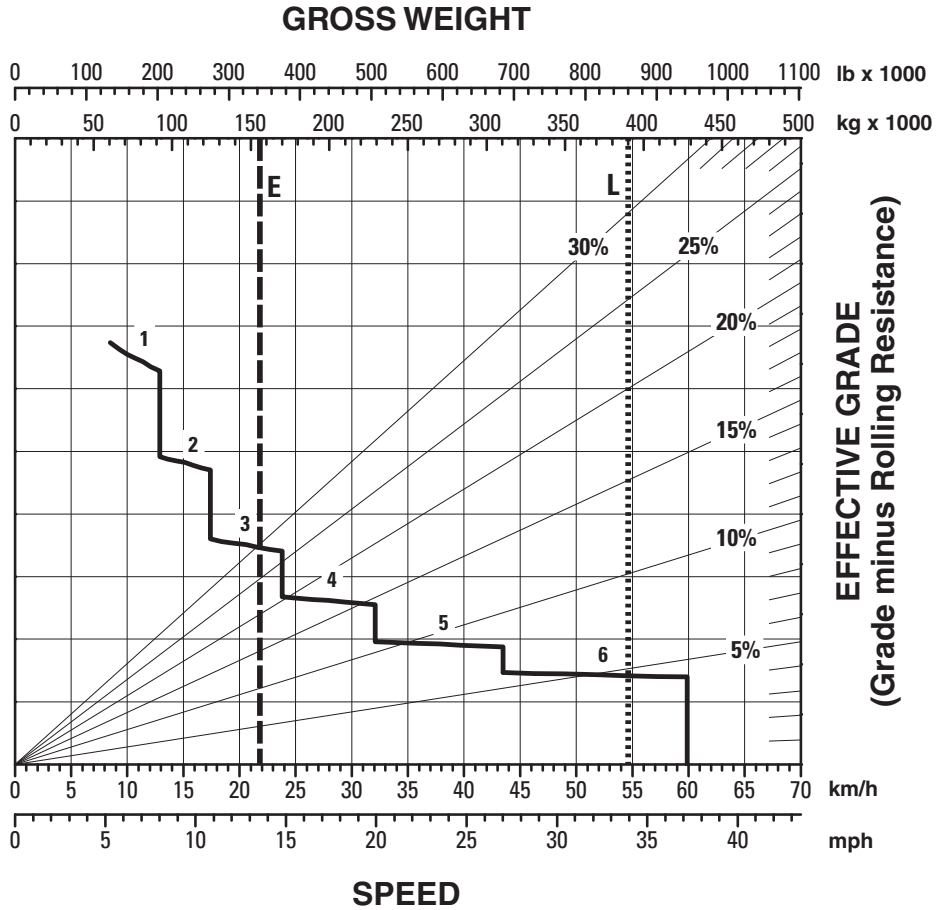

## CONTINUOUS GRADE LENGTH

**KEY**

- 1 — 1st Gear
- 2 — 2nd Gear
- 3 — 3rd Gear
- 4 — 4th Gear
- 5 — 5th Gear
- 6 — 6th Gear

**KEY**

- E — Empty
- L — Loaded

\*At Sea Level.

- Typical Field Empty Weight
- ..... Gross Machine Operating Weight  
390 089 kg (860,000 lb)

# Construction & Mining Trucks

## 793F Brake Performance

- Additional Retarding
- 450 m (1500 ft)    ● 600 m (2000 ft)
- 900 m (3000 ft)    ● 1500 m (5000 ft)

### GROSS WEIGHT

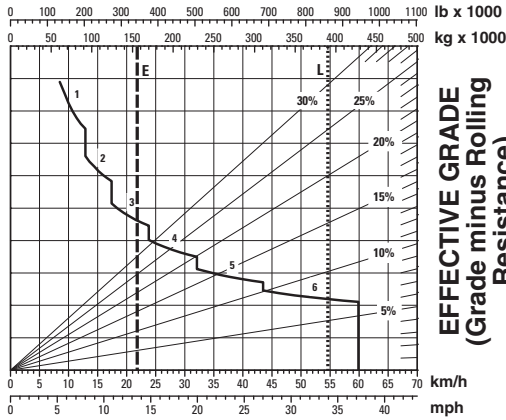

**SPEED**  
GRADE DISTANCE — 450 m (1500 ft)\*

### GROSS WEIGHT

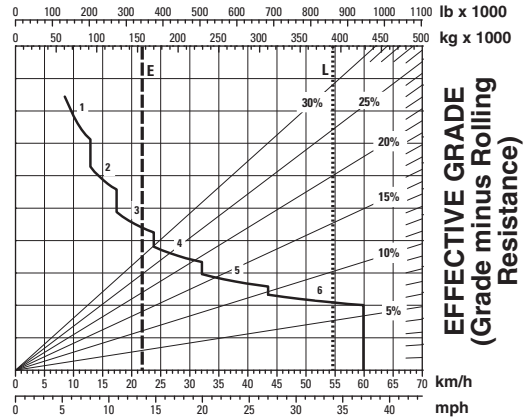

**SPEED**  
GRADE DISTANCE — 600 m (2000 ft)\*

### GROSS WEIGHT

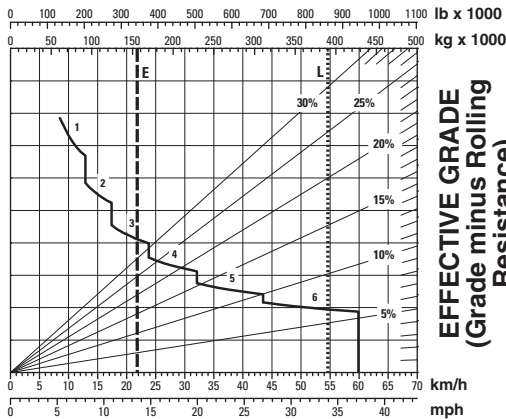

**SPEED**  
GRADE DISTANCE — 900 m (3000 ft)\*

### GROSS WEIGHT

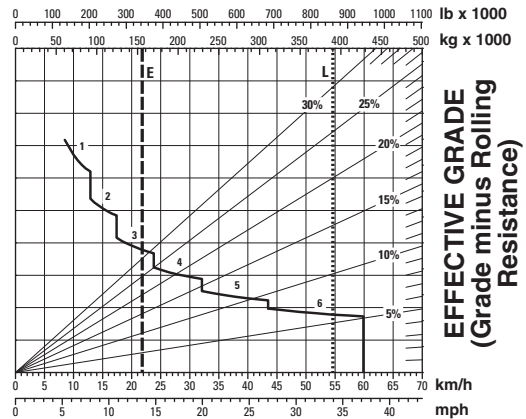

**SPEED**  
GRADE DISTANCE — 1500 m (5000 ft)\*

#### KEY

- 1 — 1st Gear
- 2 — 2nd Gear
- 3 — 3rd Gear
- 4 — 4th Gear
- 5 — 5th Gear
- 6 — 6th Gear

- Typical Field Empty Weight
- ..... Gross Machine Operating Weight  
390 089 kg (860,000 lb)

#### KEY

- E — Empty
- L — Loaded

\*At Sea Level.

**LOADED**

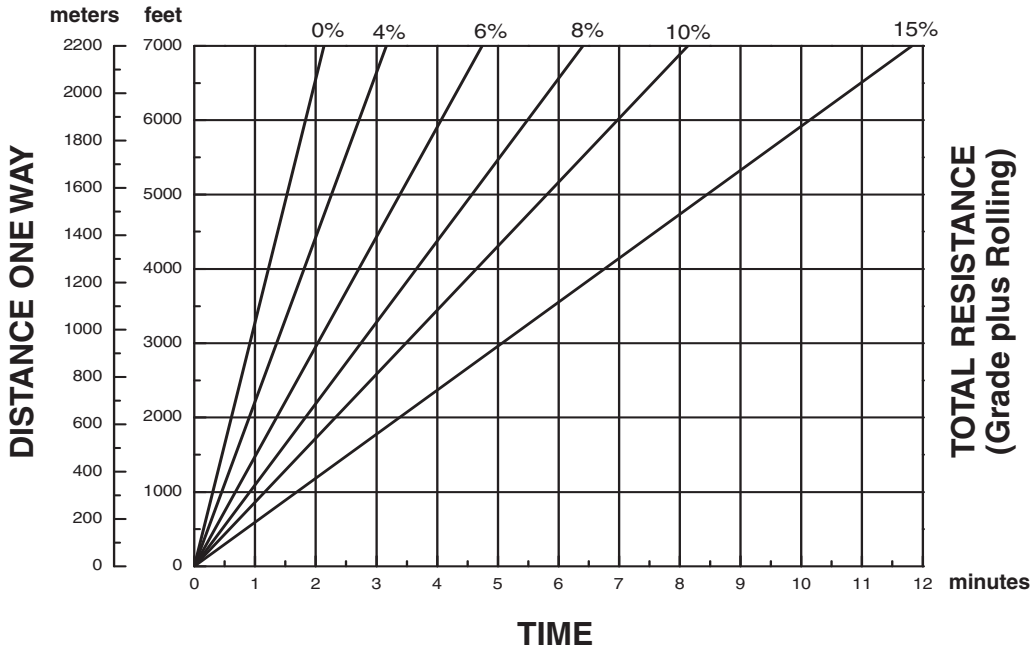

**EMPTY**

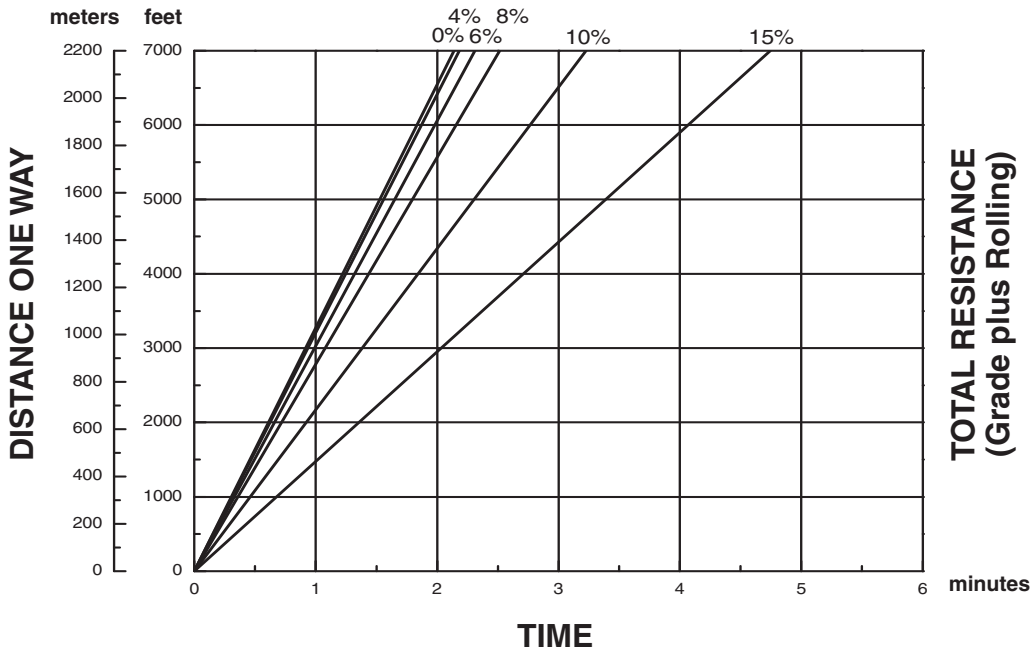



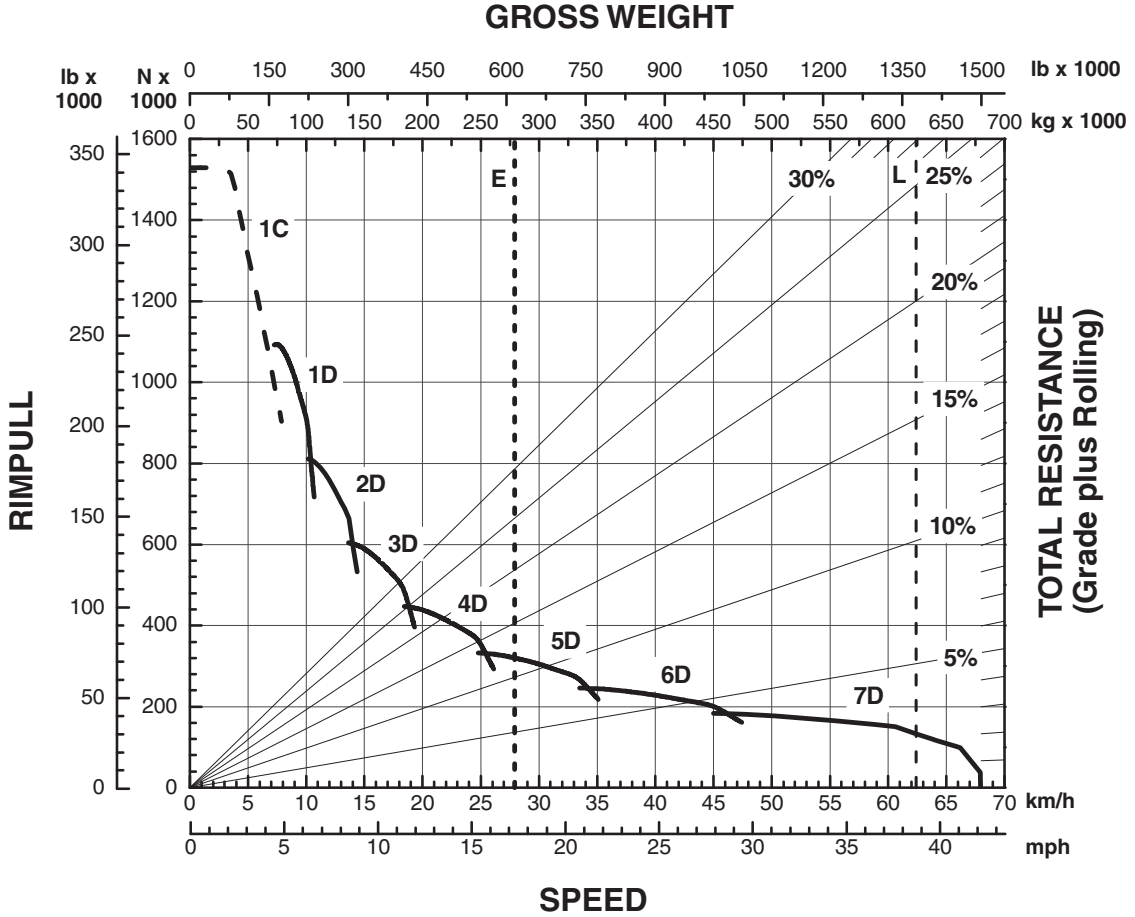

**KEY**

- 1 — 1st Gear
- 2 — 2nd Gear
- 3 — 3rd Gear
- 4 — 4th Gear
- 5 — 5th Gear
- 6 — 6th Gear
- 7 — 7th Gear

**KEY**

- E — Empty
- L — Loaded

\*At Sea Level.

- Typical Field Empty Weight
- ..... Gross Machine Operating Weight  
623 690 kg (1,375,000 lb)

- . - . - Torque Converter Drive
- Direct Drive

# 797F Brake Performance

- Steep Retarding
- Continuous Grade Retarding\*

# Construction & Mining Trucks

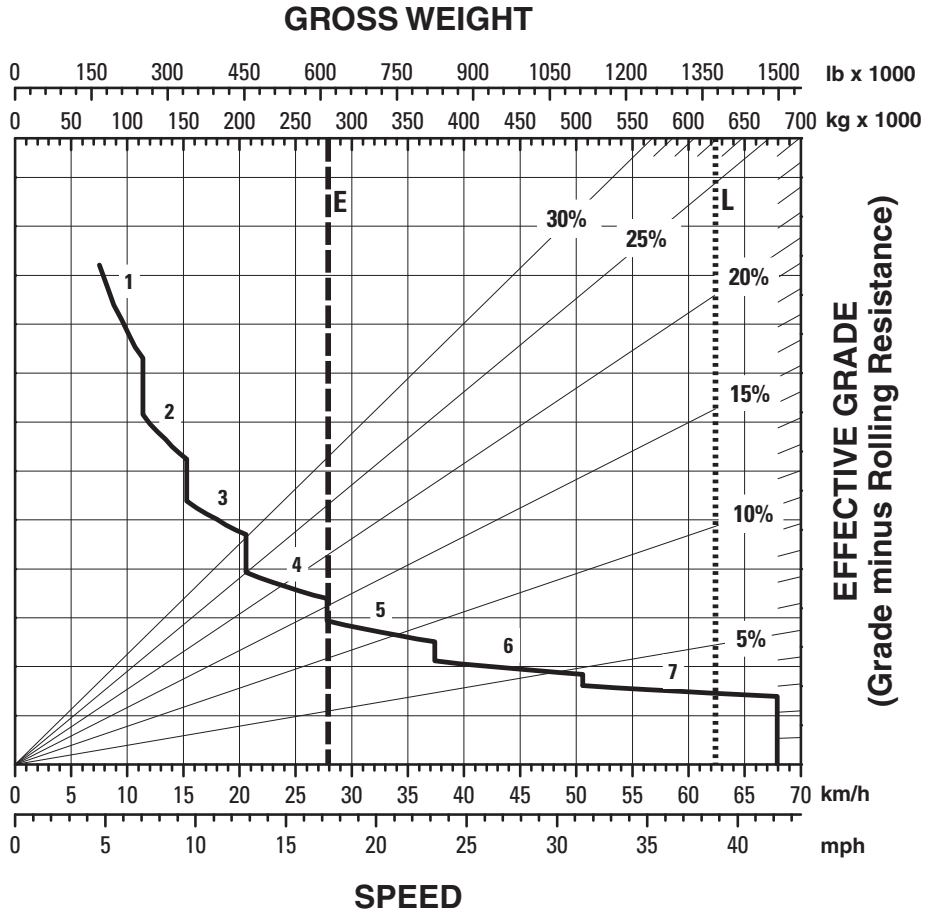

## CONTINUOUS GRADE LENGTH

### KEY

- 1 — 1st Gear
- 2 — 2nd Gear
- 3 — 3rd Gear
- 4 — 4th Gear
- 5 — 5th Gear
- 6 — 6th Gear
- 7 — 7th Gear

### KEY

- E — Empty
- L — Loaded

\*At Sea Level.

- Typical Field Empty Weight
- ..... Gross Machine Operating Weight  
623 690 kg (1,375,000 lb)

# Construction & Mining Trucks

## 797F Brake Performance

- Steep Retarding
- 450 m (1500 ft)      ● 600 m (2000 ft)
- 900 m (3000 ft)      ● 1500 m (5000 ft)

### GROSS WEIGHT

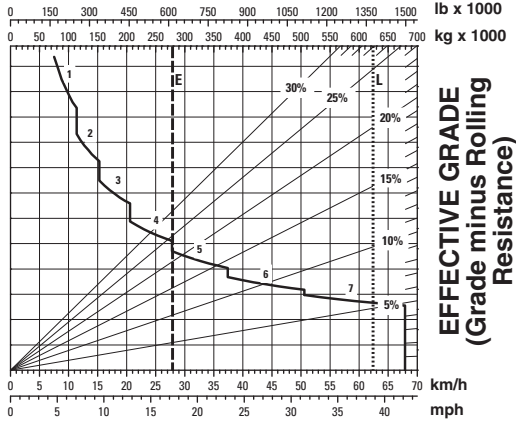

**SPEED**  
GRADE DISTANCE — 450 m (1500 ft)\*

### GROSS WEIGHT

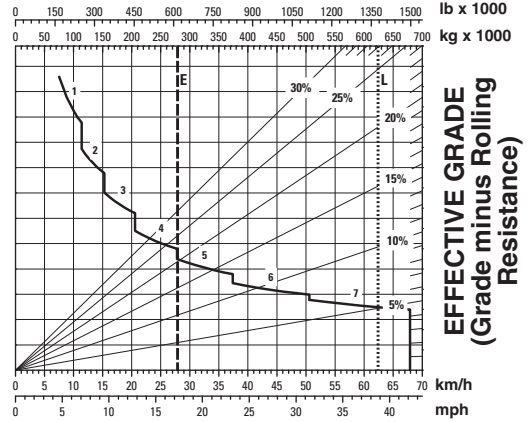

**SPEED**  
GRADE DISTANCE — 600 m (2000 ft)\*

### GROSS WEIGHT

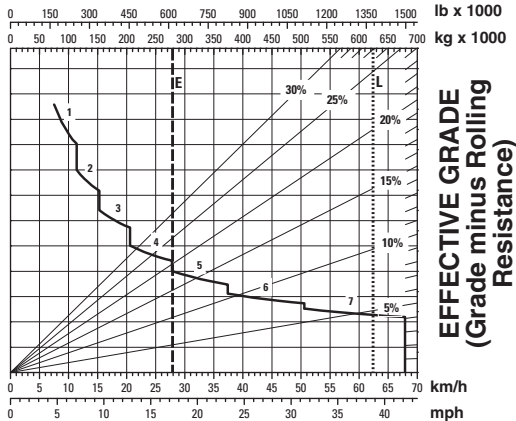

**SPEED**  
GRADE DISTANCE — 900 m (3000 ft)\*

### GROSS WEIGHT

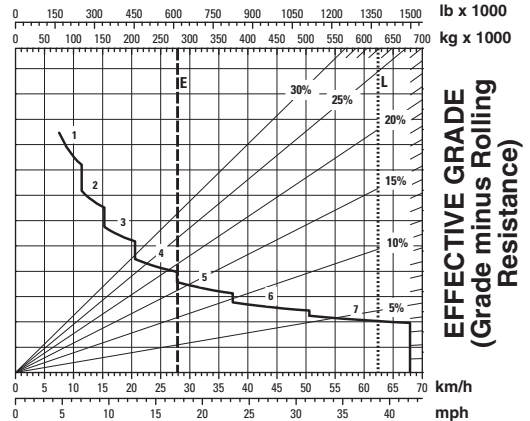

**SPEED**  
GRADE DISTANCE — 1500 m (5000 ft)\*

#### KEY

- 1 — 1st Gear
- 2 — 2nd Gear
- 3 — 3rd Gear
- 4 — 4th Gear
- 5 — 5th Gear
- 6 — 6th Gear
- 7 — 7th Gear

- Typical Field Empty Weight
- ..... Gross Machine Operating Weight  
623 690 kg (1,375,000 lb)

#### KEY

- E — Empty
- L — Loaded

\*At Sea Level.

# 797F Brake Performance

- Shallow Retarding
- Continuous Grade Retarding\*

# Construction & Mining Trucks

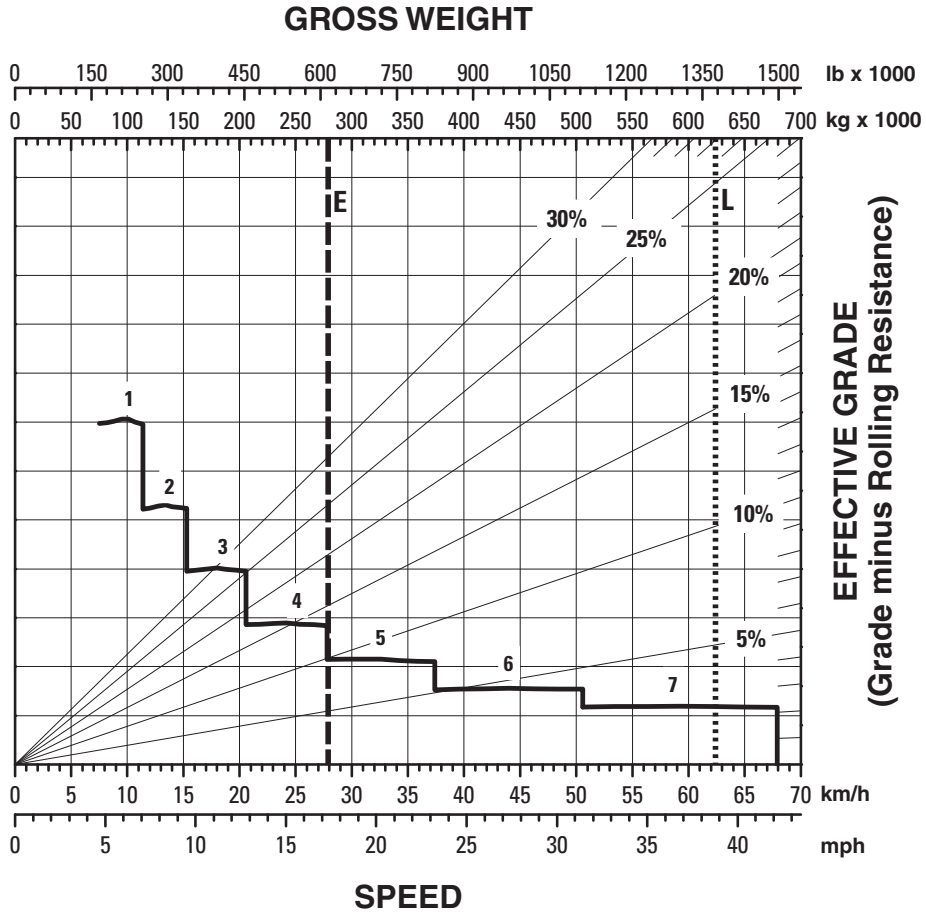

## CONTINUOUS GRADE LENGTH

**KEY**

- 1 — 1st Gear
- 2 — 2nd Gear
- 3 — 3rd Gear
- 4 — 4th Gear
- 5 — 5th Gear
- 6 — 6th Gear
- 7 — 7th Gear

**KEY**

- E — Empty
- L — Loaded

\*At Sea Level.

- Typical Field Empty Weight
- ..... Gross Machine Operating Weight  
623 690 kg (1,375,000 lb)

# Construction & Mining Trucks

## 797F Brake Performance

- Shallow Retarding
- 450 m (1500 ft)    ● 600 m (2000 ft)
- 900 m (3000 ft)    ● 1500 m (5000 ft)

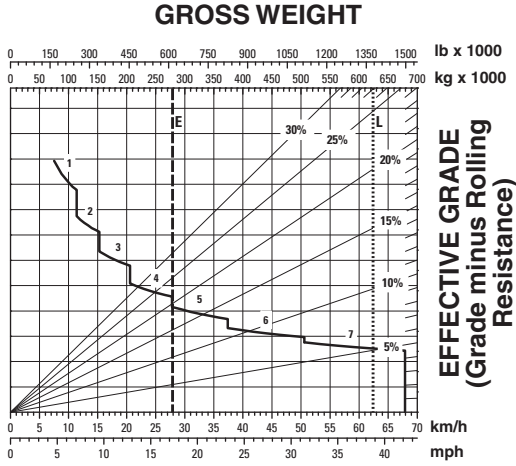

**SPEED**  
GRADE DISTANCE — 450 m (1500 ft)\*

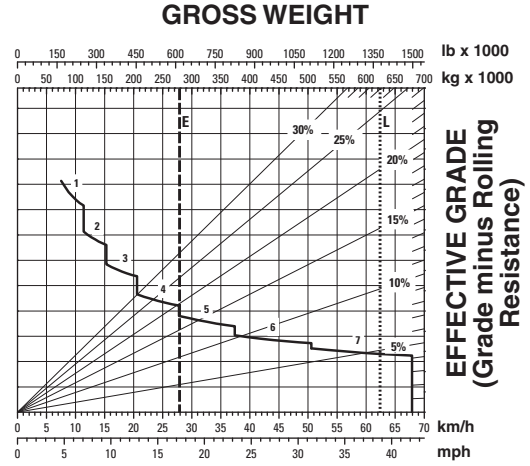

**SPEED**  
GRADE DISTANCE — 600 m (2000 ft)\*

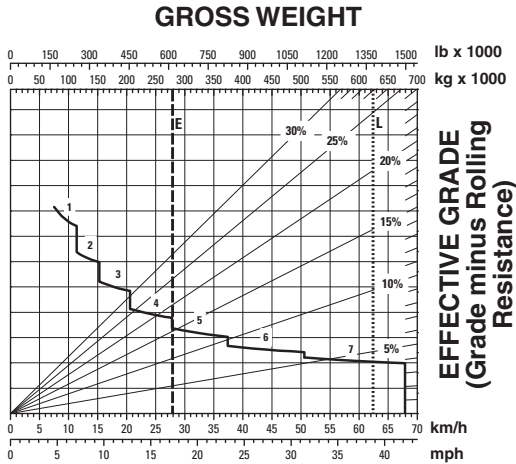

**SPEED**  
GRADE DISTANCE — 900 m (3000 ft)\*

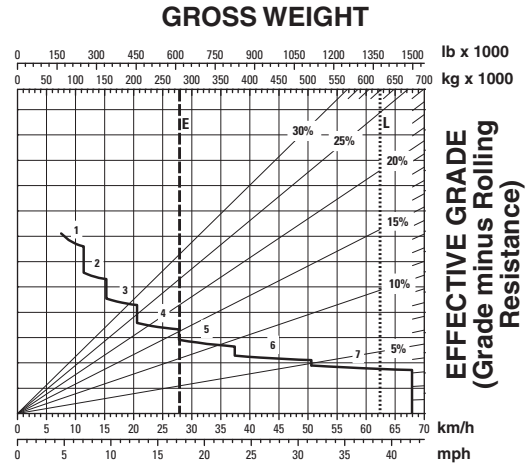

**SPEED**  
GRADE DISTANCE — 1500 m (5000 ft)\*

### KEY

- 1 — 1st Gear
- 2 — 2nd Gear
- 3 — 3rd Gear
- 4 — 4th Gear
- 5 — 5th Gear
- 6 — 6th Gear
- 7 — 7th Gear

- Typical Field Empty Weight
- ..... Gross Machine Operating Weight  
623 690 kg (1,375,000 lb)

### KEY

- E — Empty
- L — Loaded

\*At Sea Level.

**LOADED**

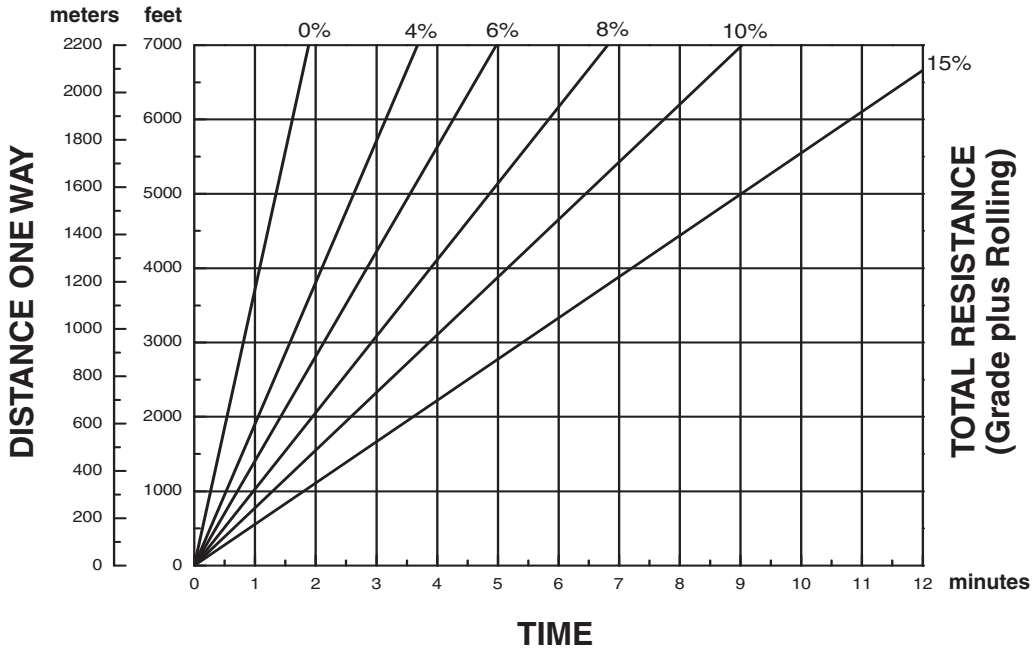

**EMPTY**

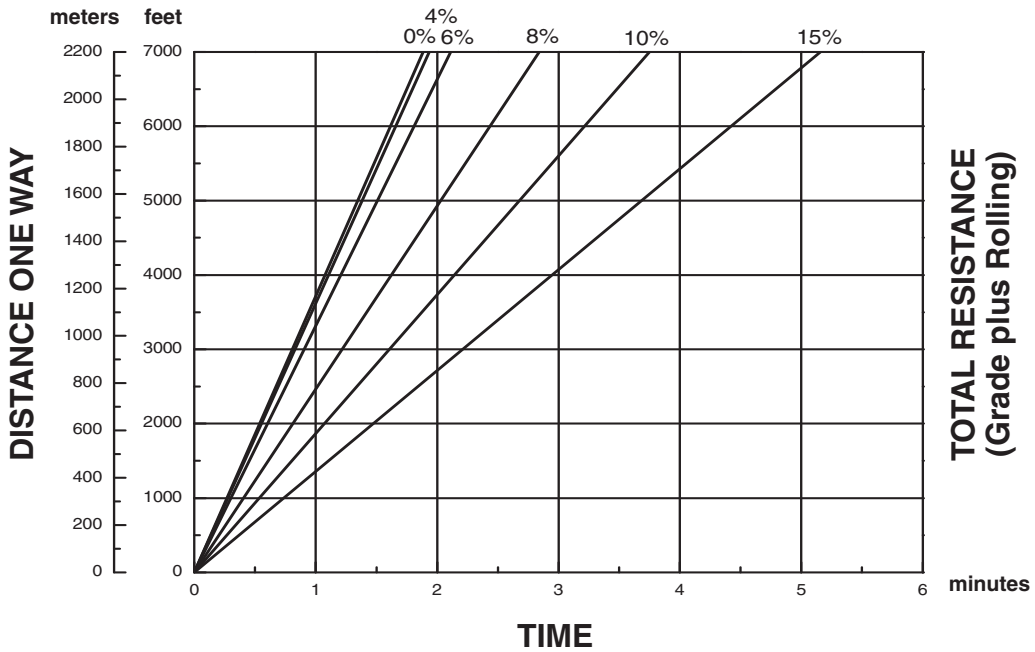



# ARTICULATED TRUCKS

## CONTENTS

Features .....	10-1
Specifications .....	10-2
Ground Pressure .....	10-5
Curves:	
725 Rimpull-Speed-Gradeability, Brake/Retarder Performance Curve, Travel Time (Loaded/Empty) .....	10-8
730/730 Ejector Rimpull-Speed-Gradeability, Brake/Retarder Performance Curve, Travel Time (Loaded/Empty) .....	10-11
735B Rimpull-Speed-Gradeability, Brake/Retarder Performance Curve, Travel Time (Loaded/Empty) .....	10-16
740B/740B EJ Rimpull-Speed-Gradeability, Brake/Retarder Performance Curve, Travel Time (Loaded/Empty) .....	10-21

### Features:

- **Cat® engines with ACERT™ Technology** meet Tier 4 Interim/Stage 3b and Tier 2 engine emission requirements through 2013. The three core elements of meeting these regulations are:
  - I) Electronics, ADEM™ A4;
  - II) Fuel delivery, Mechanical-activated Electronic Unit Injection (MEUI-C);
  - III) Air Management, Wastegate Turbocharging, Air to Air Aftercooling (ATAAC) with the proven technology of a crossflow cylinder head.
- **Cat electronically controlled transmissions** ... Transmissions purpose built and designed for articulated trucks and their applications. Electronic controls provide complete integration with the engines for smooth shifting and efficient power delivery as well as offering advanced diagnostics and trouble shooting capabilities.

- **Articulating and fully oscillating hitch** ... Links front and rear frames for exceptional maneuverability and traction on uneven terrain while eliminating damaging twisting of the frames. Bolted hitch design allows optimum material choices for the cast hitch head and the hard-wearing tube. Bolted design allows easier rebuild and repair.
- **Three-point front suspension** ... Three-point front suspension with long-stroke, low-pressure suspension cylinders provide unparalleled ride quality for operator comfort and higher average haul speeds. Front and rear suspension together with the hitch provide for excellent traction in all conditions.
- **Wide, long and low dump body design** ... For excellent loadability and high fill factors, excellent machine stability and load retention as well as a good match for other Cat loading systems. Diverging flow design also gives excellent material ejection.
- **Standard ROPS/FOPS, low sound level cab** ... Two man cab common across the range. Large cab with excellent all around visibility, ergonomic control layout and plentiful storage.
- **High capacity low pressure tires in single formation** ... For superior traction and flotation in poor underfoot conditions.





MODEL	725		730		730 Ejector	
Gross Power — SAE J1995	230 kW	<b>309 hp</b>	242 kW	<b>325 hp</b>	242 kW	<b>325 hp</b>
Net Power — SAE J1349	225 kW	<b>301 hp</b>	237 kW	<b>317 hp</b>	237 kW	<b>317 hp</b>
Net Power — ISO 9249	227 kW	<b>304 hp</b>	239 kW	<b>321 hp</b>	239 kW	<b>321 hp</b>
Net Power — EEC 80/1269	227 kW	<b>304 hp</b>	239 kW	<b>321 hp</b>	239 kW	<b>321 hp</b>
Operating Weight (Empty)*	22 260 kg	<b>49,075 lb</b>	22 850 kg	<b>50,376 lb</b>	25 550 kg	<b>56,328 lb</b>
Top Speed (Loaded)	56.8 km/h	<b>35.3 mph</b>	55.3 km/h	<b>34.4 mph</b>	55.3 km/h	<b>34.4 mph</b>
GMW — Gross Machine Weight	45 850 kg	<b>101,082 lb</b>	50 970 kg	<b>112,370 lb</b>	53 670 kg	<b>118,322 lb</b>
Distribution Empty:						
Front		<b>58.5%</b>		<b>57.5%</b>		<b>54.7%</b>
Center		<b>21.7%</b>		<b>21.9%</b>		<b>23.3%</b>
Rear		<b>19.8%</b>		<b>20.6%</b>		<b>22.0%</b>
Distribution Loaded:						
Front		<b>32.8%</b>		<b>31.1%</b>		<b>27.7%</b>
Center		<b>34.1%</b>		<b>34.7%</b>		<b>36.5%</b>
Rear		<b>33.1%</b>		<b>34.2%</b>		<b>35.8%</b>
Max. Capacity**	23.6 t	<b>26 T</b>	28.1 t	<b>31 T</b>	28.1 t	<b>31 T</b>
Struck (SAE)	11.1 m <sup>3</sup>	<b>14.5 yd<sup>3</sup></b>	13.1 m <sup>3</sup>	<b>17.1 yd<sup>3</sup></b>	13.5 m <sup>3</sup>	<b>17.7 yd<sup>3</sup></b>
Heaped (2:1) (SAE)	14.3 m <sup>3</sup>	<b>18.7 yd<sup>3</sup></b>	16.9 m <sup>3</sup>	<b>22.1 yd<sup>3</sup></b>	16.9 m <sup>3</sup>	<b>22.1 yd<sup>3</sup></b>
Tailgate Heaped SAE 2:1	15.3 m <sup>3</sup>	<b>20 yd<sup>3</sup></b>	18.5 m <sup>3</sup>	<b>24 yd<sup>3</sup></b>		—
Tailgate Struck	11.5 m <sup>3</sup>	<b>15 yd<sup>3</sup></b>	14 m <sup>3</sup>	<b>18 yd<sup>3</sup></b>		—
Engine Model	<b>ACERT C11</b>		<b>ACERT C11</b>		<b>ACERT C11</b>	
No. Cylinders	<b>6</b>		<b>6</b>		<b>6</b>	
Bore	130 mm	<b>5.1"</b>	130 mm	<b>5.1"</b>	130 mm	<b>5.1"</b>
Stroke	140 mm	<b>5.5"</b>	140 mm	<b>5.5"</b>	140 mm	<b>5.5"</b>
Displacement	11.2 L	<b>680 in<sup>3</sup></b>	11.2 L	<b>680 in<sup>3</sup></b>	11.2 L	<b>680 in<sup>3</sup></b>
Tires, Front, Center, Rear	<b>23.5R25 Radials</b>		<b>23.5R25 Radials</b>		<b>750/65 Radials</b>	
Circular Clearance Diameter	15.2 m	<b>49'9"</b>	15.2 m	<b>49'9"</b>	15.4 m	<b>50'5"</b>
Fuel Tank Refill Capacity	355 L	<b>94 U.S. gal</b>	355 L	<b>94 U.S. gal</b>	355 L	<b>94 U.S. gal</b>
<b>General Dimensions (Empty):</b>						
Height to Cab Top	3.44 m	<b>11'3"</b>	3.44 m	<b>11'3"</b>	3.45 m	<b>11'3"</b>
Wheel Base (Front-Center of Bogie)	4.67 m	<b>15'4"</b>	4.67 m	<b>15'4"</b>	4.67 m	<b>15'4"</b>
Overall Length	9.92 m	<b>32'5"</b>	9.92 m	<b>32'5"</b>	9.73 m	<b>31'9"</b>
Loading Height (Empty)	2.76 m	<b>9'1"</b>	2.89 m	<b>9'5"</b>	3.05 m	<b>10'0"</b>
Height at Full Dump	6.41 m	<b>21'1"</b>	6.50 m	<b>21'3"</b>		—
Body Length	5.78 m	<b>19'0"</b>	5.84 m	<b>19'2"</b>	5.35 m	<b>17'6"</b>
Width (Operating — Over Mirrors)	3.54 m	<b>11'7"</b>	3.54 m	<b>11'7"</b>	3.54 m	<b>11'7"</b>
Front Tire Tread	2.28 m	<b>7'5"</b>	2.28 m	<b>7'5"</b>	2.28 m	<b>7'5"</b>

\*Includes coolant, lubricant and full fuel tank.

\*\*Rating dependent on optional equipment. Maximum gross weight (empty weight plus payload) should not be exceeded.



MODEL	735B Series		740B Series		740B EJ Series	
Gross Power — SAE J1995	337 kW	<b>452 hp</b>	365 kW	<b>489 hp</b>	365 kW	<b>489 hp</b>
Net Power — SAE J1349	326 kW	<b>437 hp</b>	354 kW	<b>474 hp</b>	354 kW	<b>474 hp</b>
Net Power — ISO 14396	333 kW	<b>447 hp</b>	361 kW	<b>484 hp</b>	361 kW	<b>484 hp</b>
Operating Weight (Empty)*	32 473 kg	<b>71,591 lb</b>	34 393 kg	<b>75,824 lb</b>	36 895 kg	<b>81,340 lb</b>
Top Speed (Loaded)	51.1 km/h	<b>31.7 mph</b>	54.7 km/h	<b>34 mph</b>	54.7 km/h	<b>34 mph</b>
GMW — Gross Machine Weight	65 173 kg	<b>143,682 lb</b>	73 975 kg	<b>163,087 lb</b>	74 895 kg	<b>165,115 lb</b>
Distribution Empty:						
Front		<b>61.9%</b>		<b>60.1%</b>		<b>58.0%</b>
Center		<b>20.2%</b>		<b>21.0%</b>		<b>22.0%</b>
Rear		<b>18.0%</b>		<b>18.9%</b>		<b>20.0%</b>
Distribution Loaded:						
Front		<b>36.0%</b>		<b>35.0%</b>		<b>30.8%</b>
Center		<b>33.0%</b>		<b>33.0%</b>		<b>35.1%</b>
Rear		<b>32.0%</b>		<b>32.0%</b>		<b>34.1%</b>
Max. Capacity**	32.7 t	<b>36 T</b>	39.5 t	<b>43.5 T</b>	38 t	<b>42 T</b>
Struck (SAE)	14.7 m <sup>3</sup>	<b>19.2 yd<sup>3</sup></b>	18.5 m <sup>3</sup>	<b>24.2 yd<sup>3</sup></b>	17.8 m <sup>3</sup>	<b>23.3 yd<sup>3</sup></b>
Heaped (2:1) (SAE)	19.7 m <sup>3</sup>	<b>25.8 yd<sup>3</sup></b>	24 m <sup>3</sup>	<b>31.4 yd<sup>3</sup></b>	23.1 m <sup>3</sup>	<b>30.2 yd<sup>3</sup></b>
Tailgate Heaped SAE 2:1	20.9 m <sup>3</sup>	<b>27.3 yd<sup>3</sup></b>	25.5 m <sup>3</sup>	<b>33.5 yd<sup>3</sup></b>	—	—
Tailgate Struck	15.2 m <sup>3</sup>	<b>19.9 yd<sup>3</sup></b>	19.5 m <sup>3</sup>	<b>25.5 yd<sup>3</sup></b>	—	—
Engine Model	<b>ACERT C15</b>		<b>ACERT C15</b>		<b>ACERT C15</b>	
No. Cylinders	<b>6</b>		<b>6</b>		<b>6</b>	
Bore	137 mm	<b>5.4"</b>	137 mm	<b>5.4"</b>	137 mm	<b>5.4"</b>
Stroke	171.5 mm	<b>6.75"</b>	171.5 mm	<b>6.75"</b>	171.5 mm	<b>6.75"</b>
Displacement	15.2 L	<b>926 in<sup>3</sup></b>	15.2 L	<b>926 in<sup>3</sup></b>	15.2 L	<b>926 in<sup>3</sup></b>
Tires, Front, Center, Rear	<b>26.5R25 Radials</b>		<b>29.5R25 Radials</b>		<b>29.5R25 Radials</b>	
Circular Clearance Diameter	17.2 m	<b>56'5"</b>	17.2 m	<b>56'5"</b>	18.2 m	<b>59'6"</b>
Fuel Tank Refill Capacity	565 L	<b>149.3 U.S. gal</b>	565 L	<b>149.3 U.S. gal</b>	565 L	<b>149.3 U.S. gal</b>
<b>General Dimensions (Empty):</b>						
Height to Cab Top	3.7 m	<b>12'1"</b>	3.75 m	<b>12'3"</b>	3.75 m	<b>12'3"</b>
Wheel Base (Front-Center of Bogie)	5.23 m	<b>17'2"</b>	5.23 m	<b>17'2"</b>	5.58 m	<b>18'3"</b>
Overall Length	10.99 m	<b>36'1"</b>	10.99 m	<b>36'1"</b>	11.69 m	<b>38'4"</b>
Loading Height (Empty)	2.98 m	<b>9'8"</b>	3.2 m	<b>10'6"</b>	3.07 m	<b>10'1"</b>
Height at Full Dump	6.81 m	<b>22'4"</b>	7.1 m	<b>23'4"</b>	—	—
Body Length	6.09 m	<b>20'0"</b>	6.3 m	<b>20'6"</b>	6.73 m	<b>22'1"</b>
Width (Operating — Over Mirrors)	3.82 m	<b>12'6"</b>	3.82 m	<b>12'6"</b>	3.82 m	<b>12'6"</b>
Front Tire Tread	2.69 m	<b>8'8"</b>	2.69 m	<b>8'8"</b>	2.69 m	<b>8'8"</b>

\*Includes coolant, lubricant and full fuel tank.

\*\*Rating dependent on optional equipment. Maximum gross weight (empty weight plus payload) should not be exceeded.

# B Series Articulated Trucks

## Specifications ● Tier 2



MODEL	735B Series		740B Series		740B EJ Series	
Gross Power — SAE J1995	336 kW	<b>450 hp</b>	361 kW	<b>484 hp</b>	361 kW	<b>484 hp</b>
Net Power — SAE J1349	326 kW	<b>438 hp</b>	352 kW	<b>472 hp</b>	352 kW	<b>472 hp</b>
Net Power — ISO 9249	330 kW	<b>442 hp</b>	356 kW	<b>477 hp</b>	356 kW	<b>477 hp</b>
Net Power — EEC 80/1269	330 kW	<b>442 hp</b>	356 kW	<b>477 hp</b>	356 kW	<b>477 hp</b>
Operating Weight (Empty)*	32 206 kg	<b>71,002 lb</b>	34 127 kg	<b>75,237 lb</b>	36 629 kg	<b>80,753 lb</b>
Top Speed (Loaded)	51.1 km/h	<b>31.7 mph</b>	54.7 km/h	<b>34 mph</b>	54.7 km/h	<b>34 mph</b>
GMW — Gross Machine Weight	64 906 kg	<b>143,093 lb</b>	73 709 kg	<b>162,500 lb</b>	74 629 kg	<b>164,529 lb</b>
Distribution Empty:						
Front		<b>61.2%</b>		<b>59.5%</b>		<b>57.4%</b>
Center		<b>20.5%</b>		<b>21.3%</b>		<b>22.3%</b>
Rear		<b>18.3%</b>		<b>19.2%</b>		<b>20.3%</b>
Distribution Loaded:						
Front		<b>35.6%</b>		<b>34.6%</b>		<b>30.4%</b>
Center		<b>32.8%</b>		<b>33.2%</b>		<b>35.3%</b>
Rear		<b>31.7%</b>		<b>32.2%</b>		<b>34.3%</b>
Max. Capacity**	32.7 t	<b>36 T</b>	39.5 t	<b>43.5 T</b>	38 t	<b>42 T</b>
Struck (SAE)	14.7 m <sup>3</sup>	<b>19.2 yd<sup>3</sup></b>	18.5 m <sup>3</sup>	<b>24.2 yd<sup>3</sup></b>	17.8 m <sup>3</sup>	<b>23.3 yd<sup>3</sup></b>
Heaped (2:1) (SAE)	19.7 m <sup>3</sup>	<b>25.8 yd<sup>3</sup></b>	24 m <sup>3</sup>	<b>31.4 yd<sup>3</sup></b>	23.1 m <sup>3</sup>	<b>30.2 yd<sup>3</sup></b>
Tailgate Heaped SAE 2:1	20.9 m <sup>3</sup>	<b>27.3 yd<sup>3</sup></b>	25.5 m <sup>3</sup>	<b>33.5 yd<sup>3</sup></b>	—	—
Tailgate Struck	15.2 m <sup>3</sup>	<b>19.9 yd<sup>3</sup></b>	19.5 m <sup>3</sup>	<b>25.5 yd<sup>3</sup></b>	—	—
Engine Model	<b>ACERT C15</b>		<b>ACERT C15</b>		<b>ACERT C15</b>	
No. Cylinders	<b>6</b>		<b>6</b>		<b>6</b>	
Bore	137 mm	<b>5.4"</b>	137 mm	<b>5.4"</b>	137 mm	<b>5.4"</b>
Stroke	171.5 mm	<b>6.75"</b>	171.5 mm	<b>6.75"</b>	171.5 mm	<b>6.75"</b>
Displacement	15.2 L	<b>926 in<sup>3</sup></b>	15.2 L	<b>926 in<sup>3</sup></b>	15.2 L	<b>926 in<sup>3</sup></b>
Tires, Front, Center, Rear	<b>26.5R25 Radials</b>		<b>29.5R25 Radials</b>		<b>29.5R25 Radials</b>	
Circular Clearance Diameter	17.2 m	<b>56'5"</b>	17.2 m	<b>56'5"</b>	18.2 m	<b>59'6"</b>
Fuel Tank Refill Capacity	565 L	<b>149.3 U.S. gal</b>	565 L	<b>149.3 U.S. gal</b>	565 L	<b>149.3 U.S. gal</b>
<b>General Dimensions (Empty):</b>						
Height to Cab Top	3.7 m	<b>12'1"</b>	3.75 m	<b>12'3"</b>	3.75 m	<b>12'3"</b>
Wheel Base (Front-Center of Bogie)	5.23 m	<b>17'2"</b>	5.23 m	<b>17'2"</b>	5.58 m	<b>18'3"</b>
Overall Length	10.99 m	<b>36'1"</b>	10.99 m	<b>36'1"</b>	11.69 m	<b>38'4"</b>
Loading Height (Empty)	2.98 m	<b>9'8"</b>	3.2 m	<b>10'6"</b>	3.07 m	<b>10'1"</b>
Height at Full Dump	6.81 m	<b>22'4"</b>	7.1 m	<b>23'4"</b>	—	—
Body Length	6.09 m	<b>20'0"</b>	6.3 m	<b>20'6"</b>	6.73 m	<b>22'1"</b>
Width (Operating — Over Mirrors)	3.82 m	<b>12'6"</b>	3.82 m	<b>12'6"</b>	3.82 m	<b>12'6"</b>
Front Tire Tread	2.69 m	<b>8'8"</b>	2.69 m	<b>8'8"</b>	2.69 m	<b>8'8"</b>

\*Includes coolant, lubricant and full fuel tank.

\*\*Rating dependent on optional equipment. Maximum gross weight (empty weight plus payload) should not be exceeded.

### Use of Ground Pressure Charts

Articulated trucks are normally equipped with wide base radial tires, for improved flotation in poor underfoot conditions. Ground pressure is a function of tire deflection and is also affected by tire penetration. The charts in this section provide a means to estimate ground pressure for 0 and 76 mm (3") tire penetration, when gross vehicle weight, axle load distribution and tire inflation pressure are known. The ground pressure charts on the following pages are based on Michelin XADN tire characteristics. Results may differ for other tread patterns.

Tire load can be calculated by the following formula:

$$\text{Tire load} = \frac{\text{Heaviest Axle Load}}{2}$$

#### Example

Find the ground pressure generated by a 725 fully loaded with zero and 76 mm (3") tire penetration. The machine is equipped with standard Michelin 23.5R25 tires, inflated to the recommended pressure.

$$725 \text{ Tire Load} = \frac{45\,850 \text{ kg} \times 0.34}{2} = 7795 \text{ kg}$$

$$725 \text{ Tire Load} = \frac{101,082 \text{ lb} \times 0.34}{2} = 17,184 \text{ lb}$$

From the tire section in this book, inflation pressure for the 725 is 325 kPa = 3.25 bar (47 psi).

From the ground pressure chart for 23.5R25 tires, Ground pressure = 3.1 kg/cm<sup>2</sup> (44 psi) with zero tire penetration.

Ground pressure = 1.4 kg/cm<sup>2</sup> (21 psi) with 76 mm (3") tire penetration.

See the Wheel Tractor Scraper section for explanation on using:

- Rimpull-Speed-Gradeability Curves
- Retarder Curves
- Travel Time Charts

See the Construction and Mining Trucks section for Hauling Unit Fixed Times.

**23.5R25 Tires\***

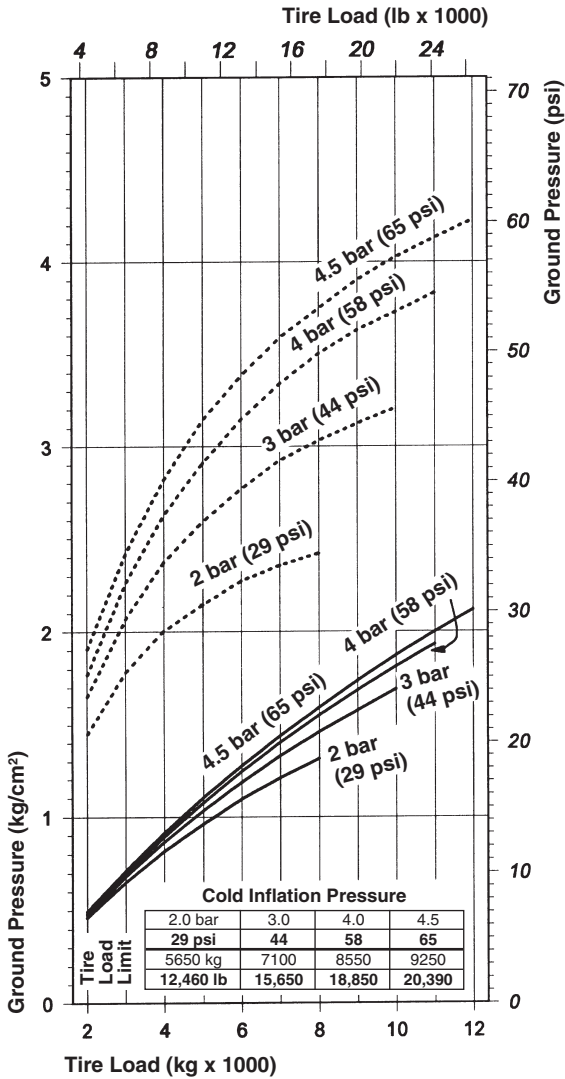

**30/65R25 Tires\***

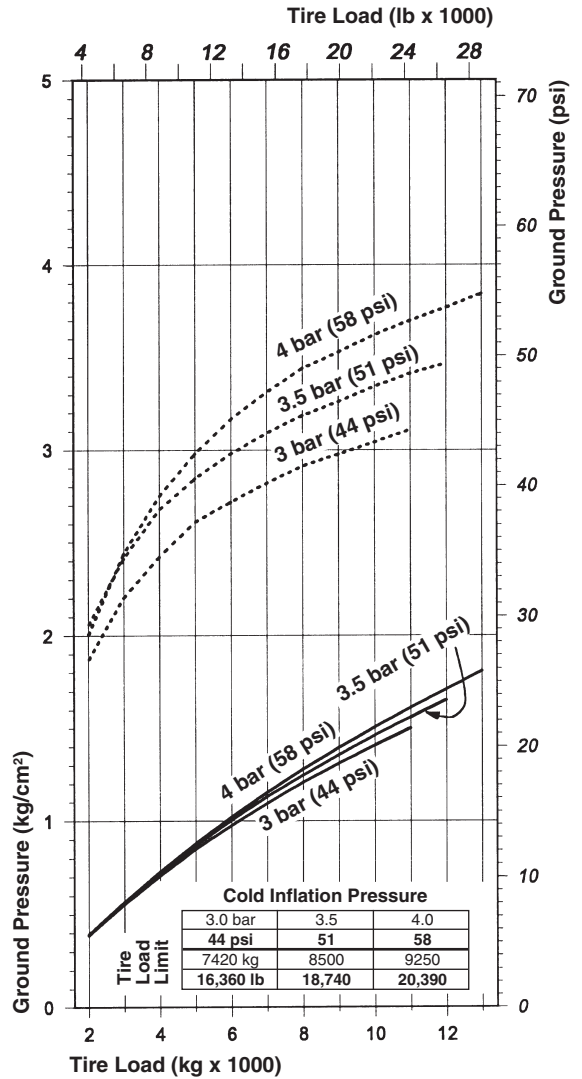

**KEY**

- Zero Penetration (Flat Plate)
- 76 mm (3") Penetration

\*Charts based on Michelin XADN tire characteristics. Results may differ for other tread patterns and/or brands. Charts are to be used to calculate ground pressure. To determine the inflation as a function of load and conditions or when loads exceed tire load limit, contact your tire manufacturer representative.

### 26.5R25 Tires\*

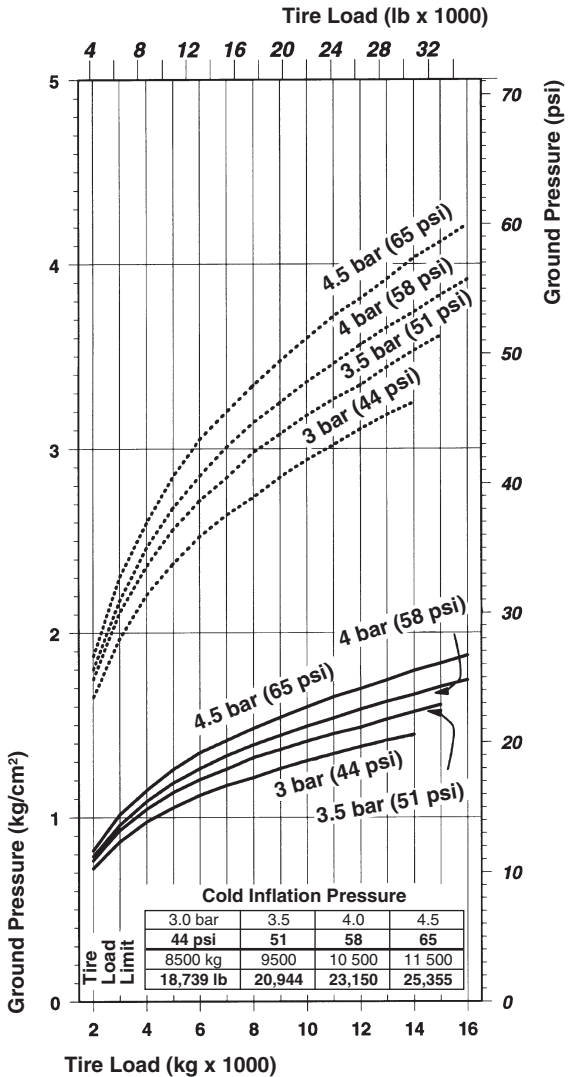

### 29.5R25 Tires\*

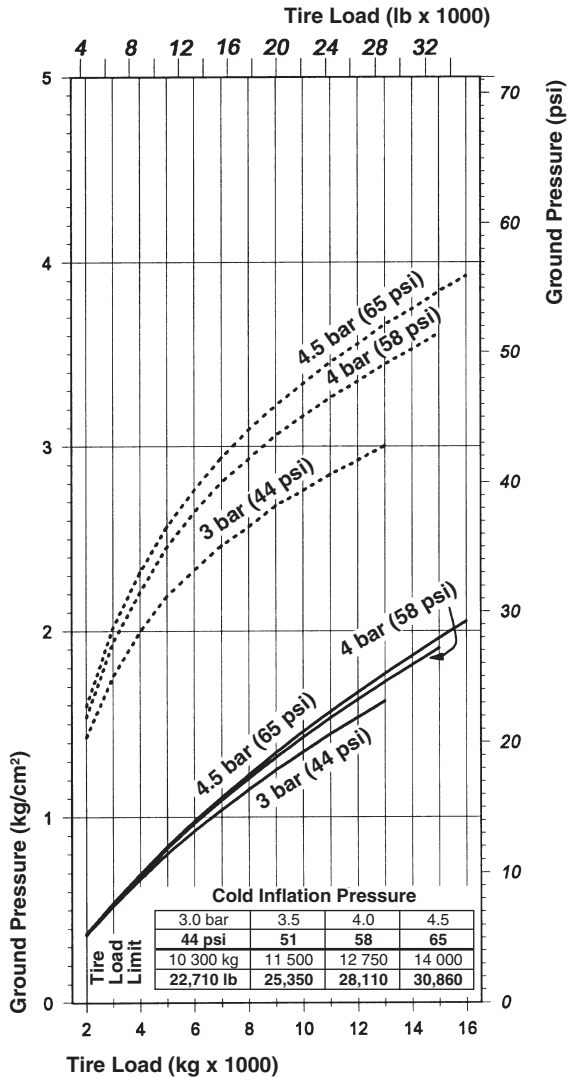

**KEY**  
 ----- Zero Penetration (Flat Plate)  
 \_\_\_\_\_ 76 mm (3") Penetration

\*Charts based on Michelin XADN tire characteristics. Results may differ for other tread patterns and/or brands. Charts are to be used to calculate ground pressure. To determine the inflation as a function of load and conditions or when loads exceed tire load limit, contact your tire manufacturer representative.

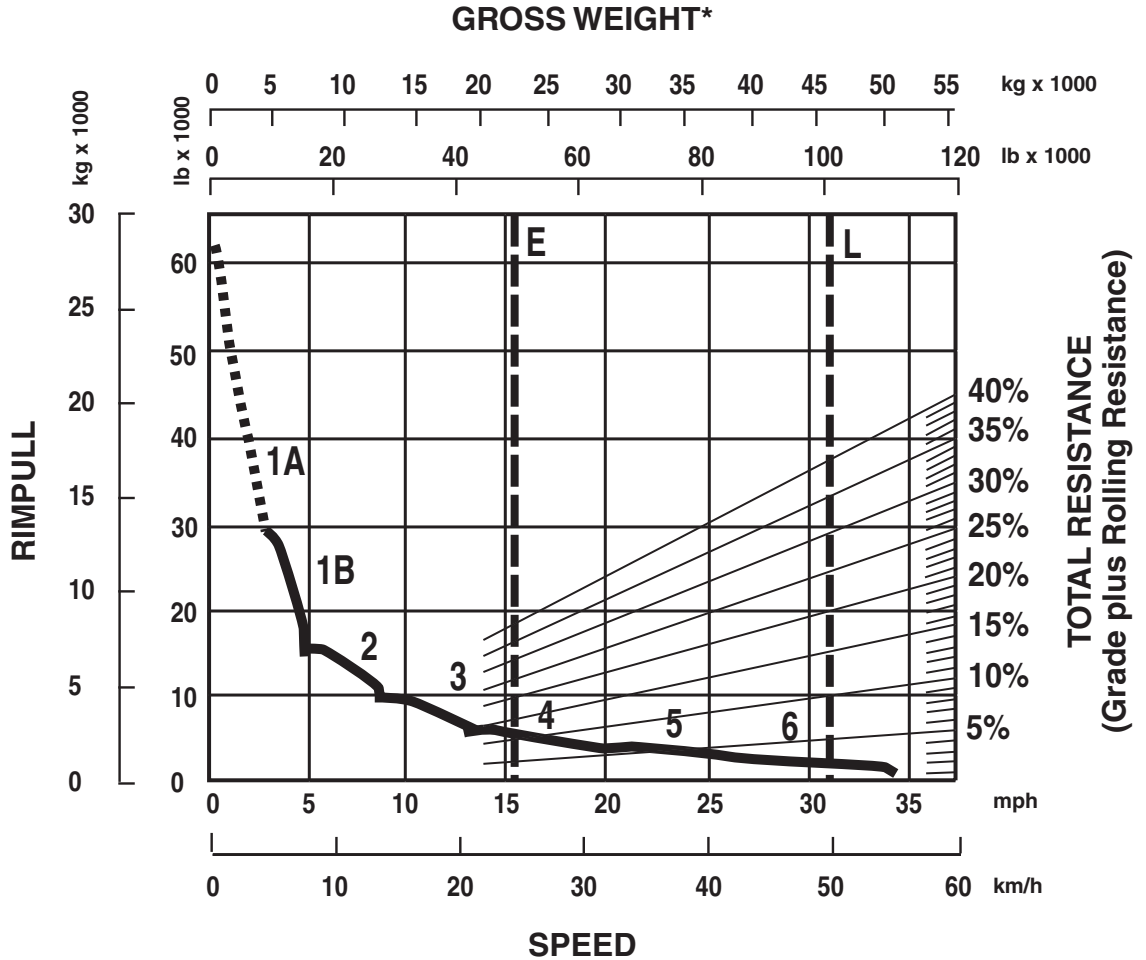

**KEY**

- 1A — 1st Gear (Converter Drive)
- 1B — 1st Gear (Direct Drive)
- 2 — 2nd Gear
- 3 — 3rd Gear
- 4 — 4th Gear
- 5 — 5th Gear
- 6 — 6th Gear

**KEY**

- E — Empty 22 260 kg (49,075 lb)
- L — Loaded 45 850 kg (101,082 lb)

\*At sea level.

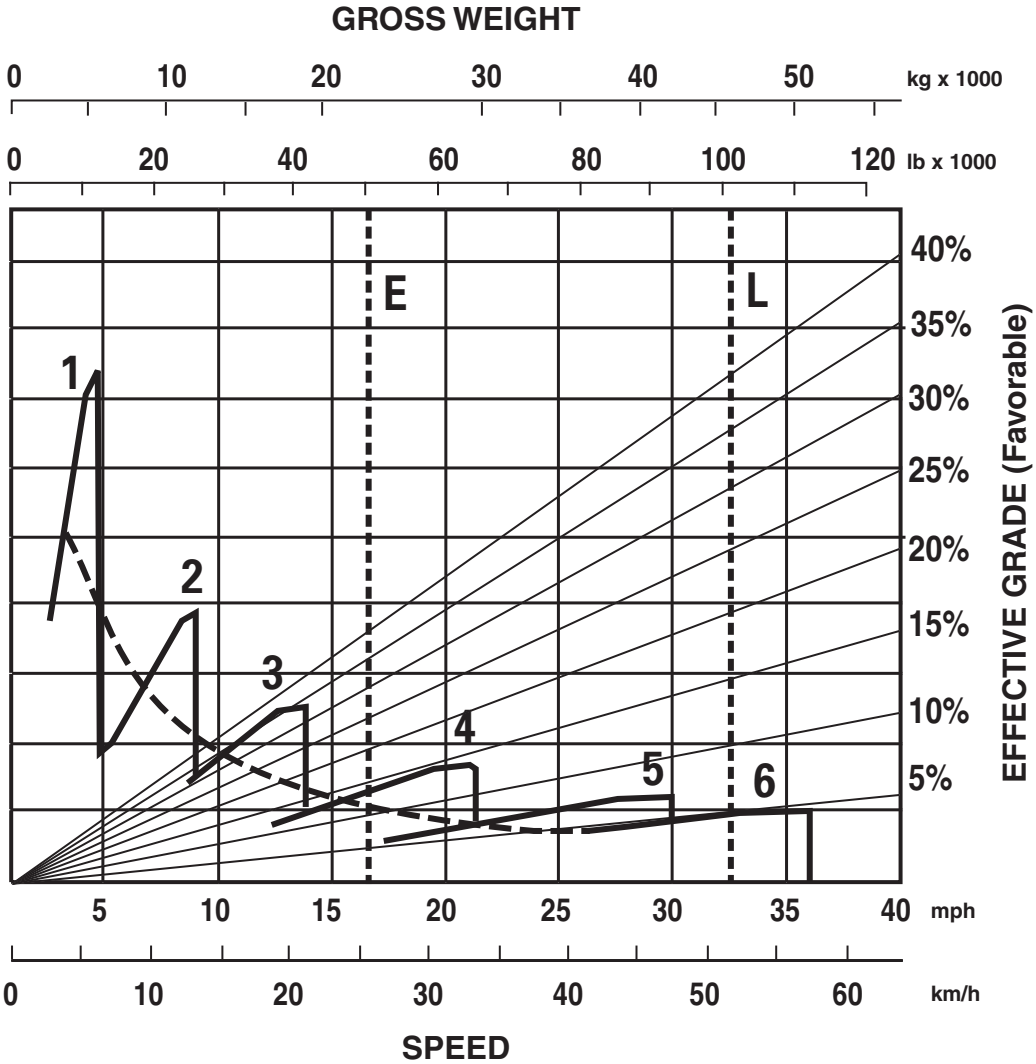

- KEY**
- 1 — 1st Gear
  - 2 — 2nd Gear
  - 3 — 3rd Gear
  - 4 — 4th Gear
  - 5 — 5th Gear
  - 6 — 6th Gear

- KEY**
- E — Empty 22 260 kg (49,075 lb)
  - L — Loaded 45 850 kg (101,082 lb)



**LOADED**

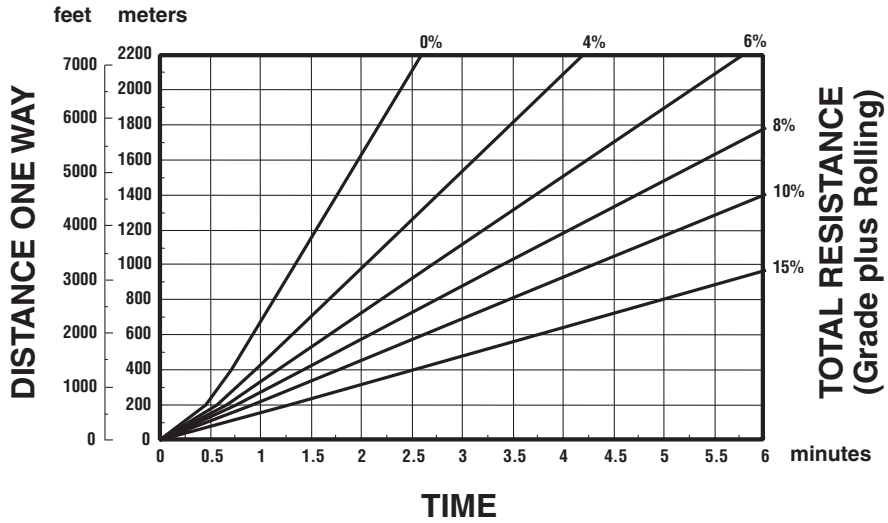

**EMPTY**

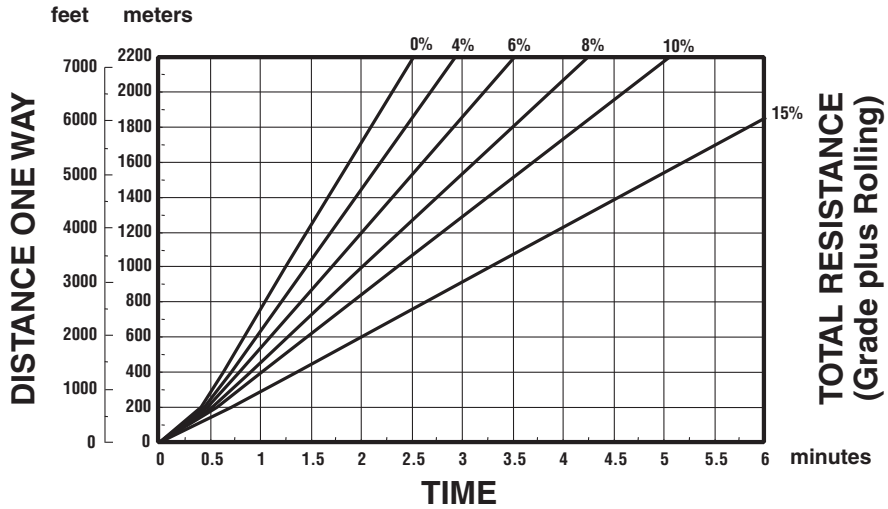

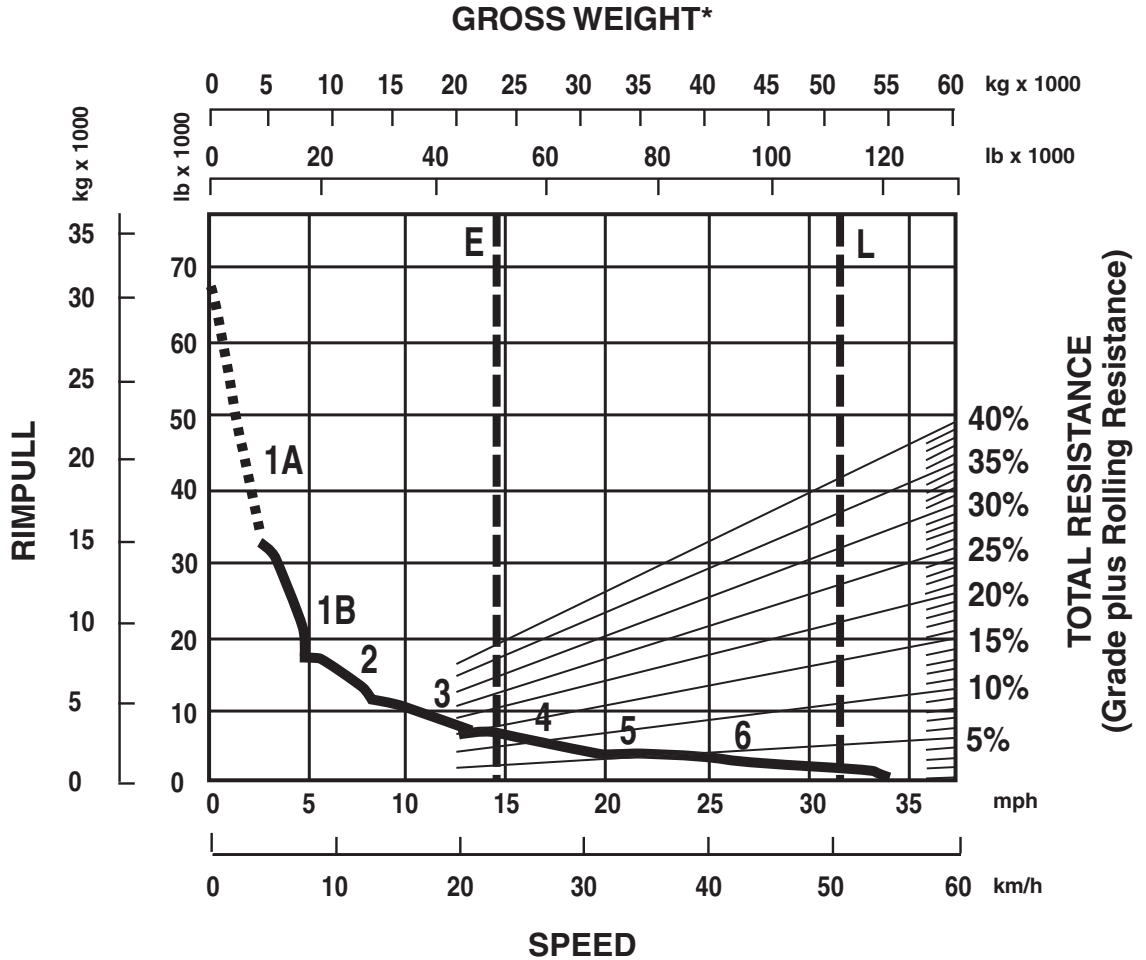

KEY

- 1A — 1st Gear (Converter Drive)
- 1B — 1st Gear (Direct Drive)
- 2 — 2nd Gear
- 3 — 3rd Gear
- 4 — 4th Gear
- 5 — 5th Gear
- 6 — 6th Gear

KEY

- E — Empty 22 850 kg (50,376 lb)
- L — Loaded 50 970 kg (112,370 lb)

\*At sea level.

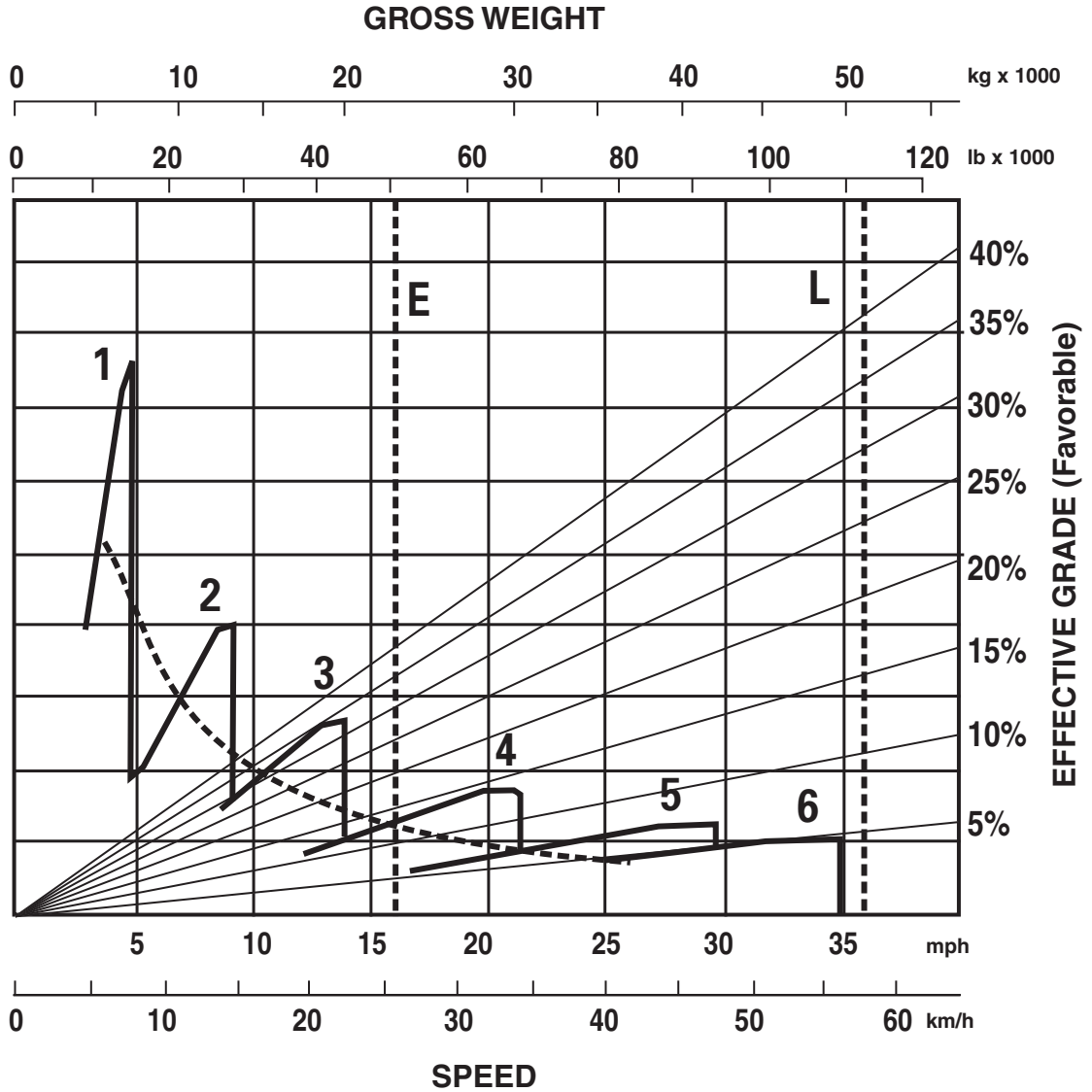

- KEY**
- 1 — 1st Gear
  - 2 — 2nd Gear
  - 3 — 3rd Gear
  - 4 — 4th Gear
  - 5 — 5th Gear
  - 6 — 6th Gear

- KEY**
- E — Empty 22 850 kg (50,376 lb)
  - L — Loaded 50 970 kg (112,370 lb)

**LOADED**

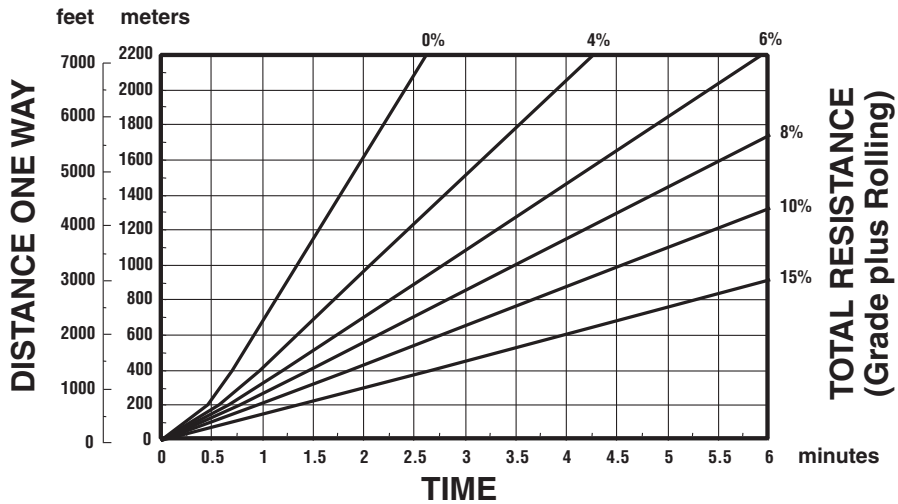

**EMPTY**

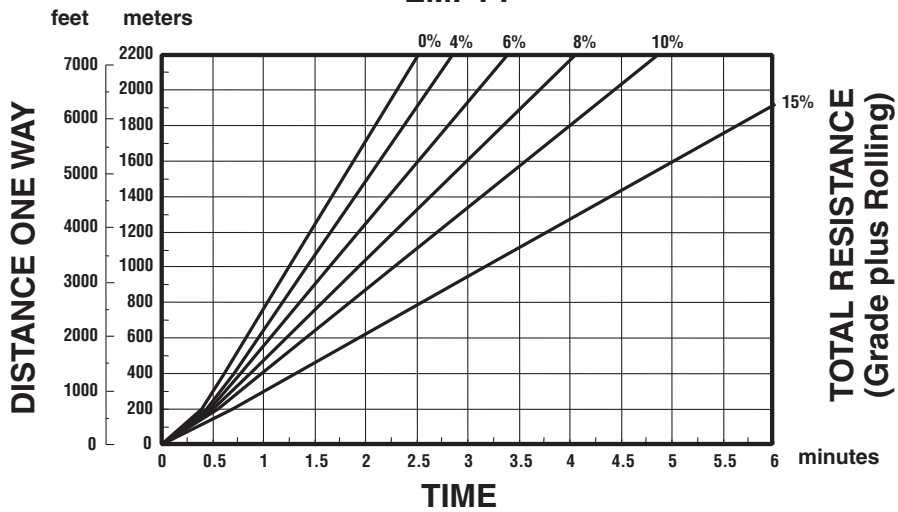

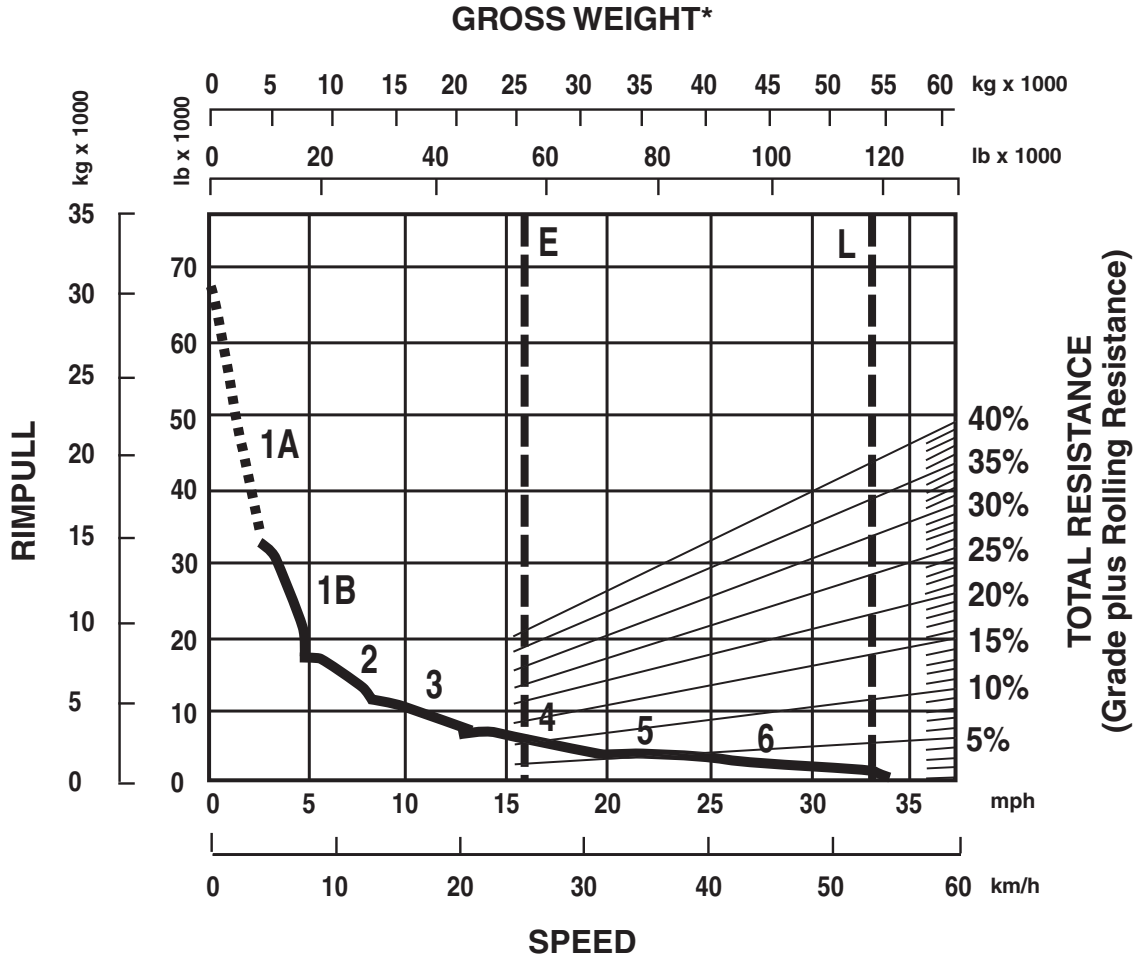

**KEY**

- 1A — 1st Gear (Converter Drive)
- 1B — 1st Gear (Direct Drive)
- 2 — 2nd Gear
- 3 — 3rd Gear
- 4 — 4th Gear
- 5 — 5th Gear
- 6 — 6th Gear

**KEY**

- E — Empty 25 550 kg (56,328 lb)
- L — Loaded 53 670 kg (118,322 lb)

\*At sea level.

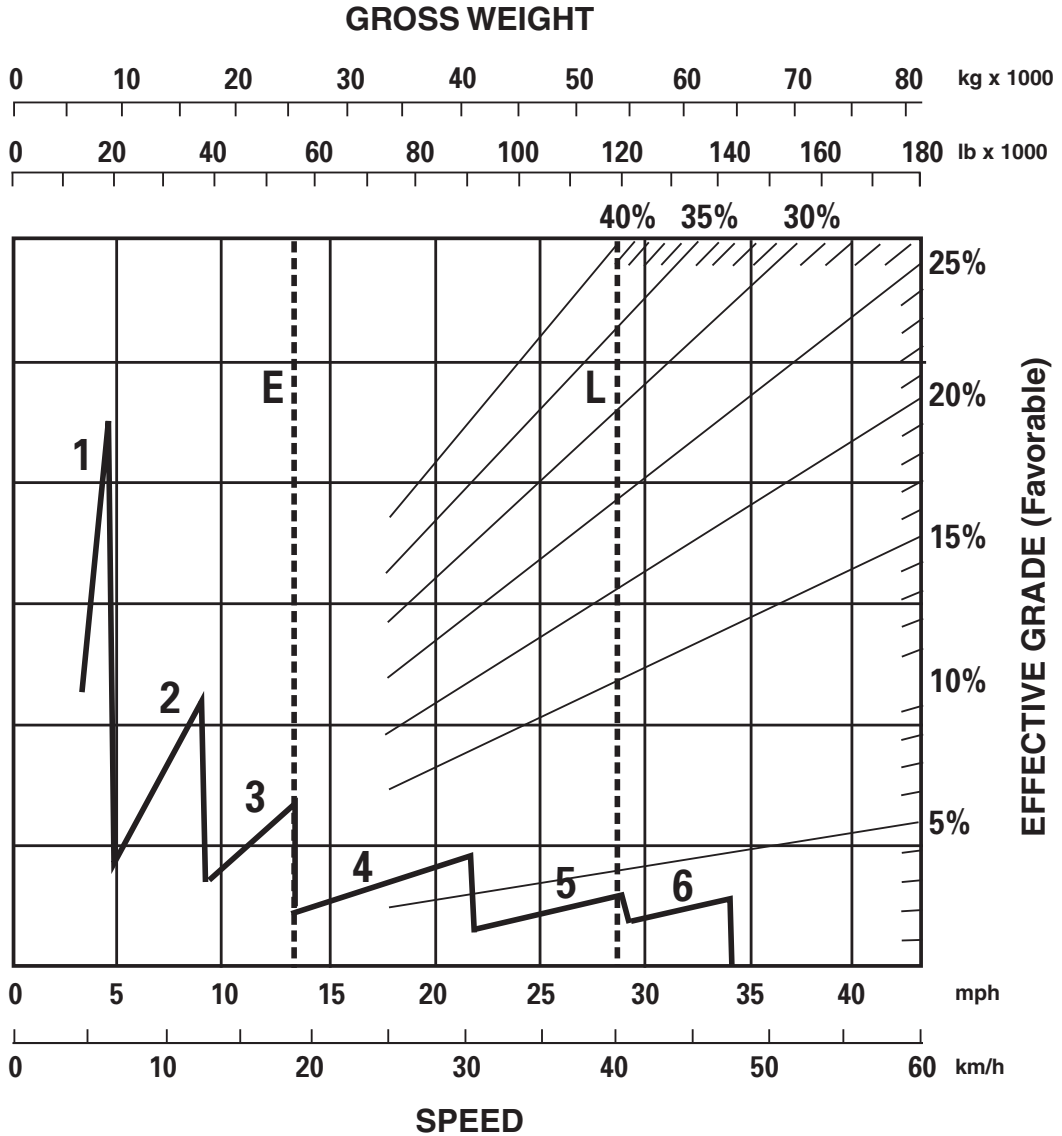

- KEY**
- 1 — 1st Gear
  - 2 — 2nd Gear
  - 3 — 3rd Gear
  - 4 — 4th Gear
  - 5 — 5th Gear
  - 6 — 6th Gear

- KEY**
- E — Empty 25 550 kg (56,328 lb)
  - L — Loaded 53 670 kg (118,322 lb)

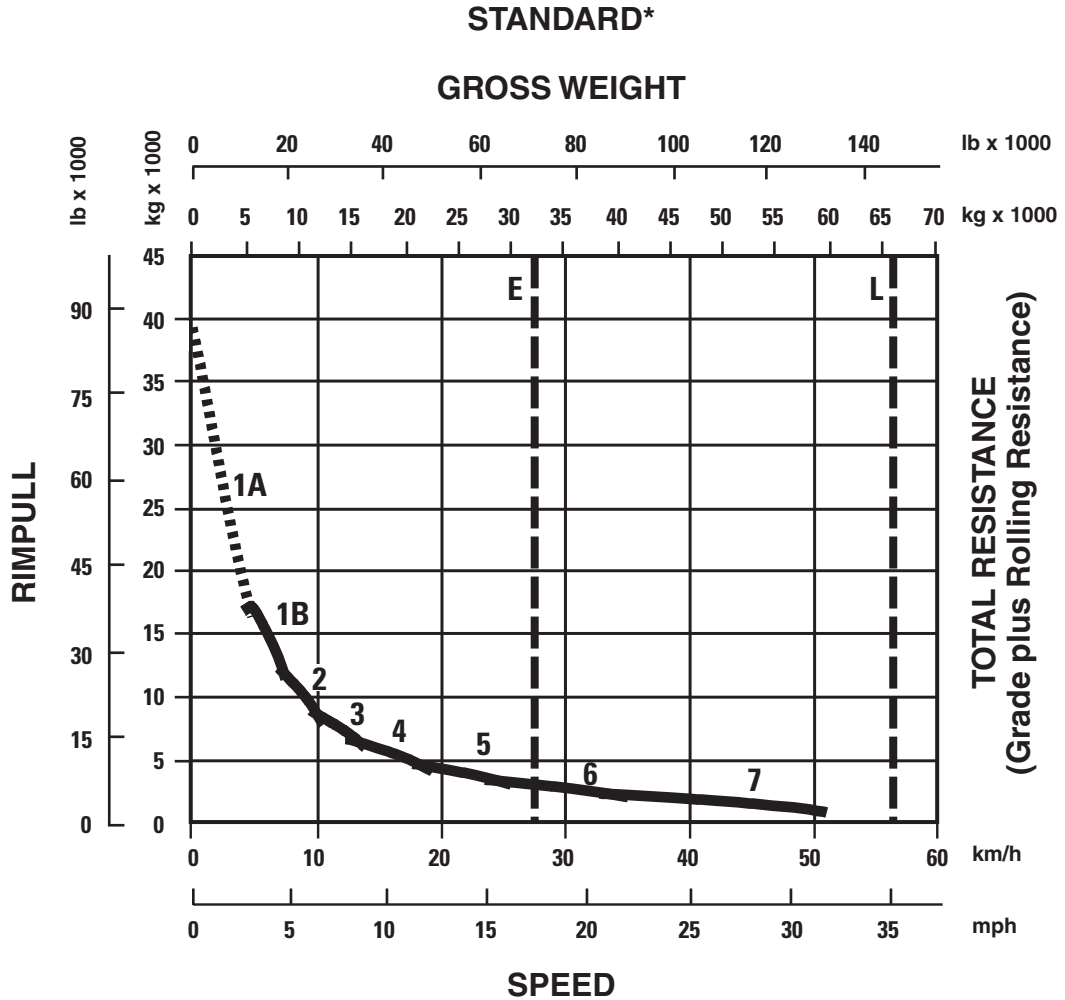

**KEY**

- 1A — 1st Gear (Converter Drive)
- 1B — 1st Gear (Direct Drive)
- 2 — 2nd Gear
- 3 — 3rd Gear
- 4 — 4th Gear
- 5 — 5th Gear
- 6 — 6th Gear
- 7 — 7th Gear

**KEY**

- E — Empty 32 473 kg (71,591 lb)
- L — Loaded 65 173 kg (143,682 lb)

\*At sea level.

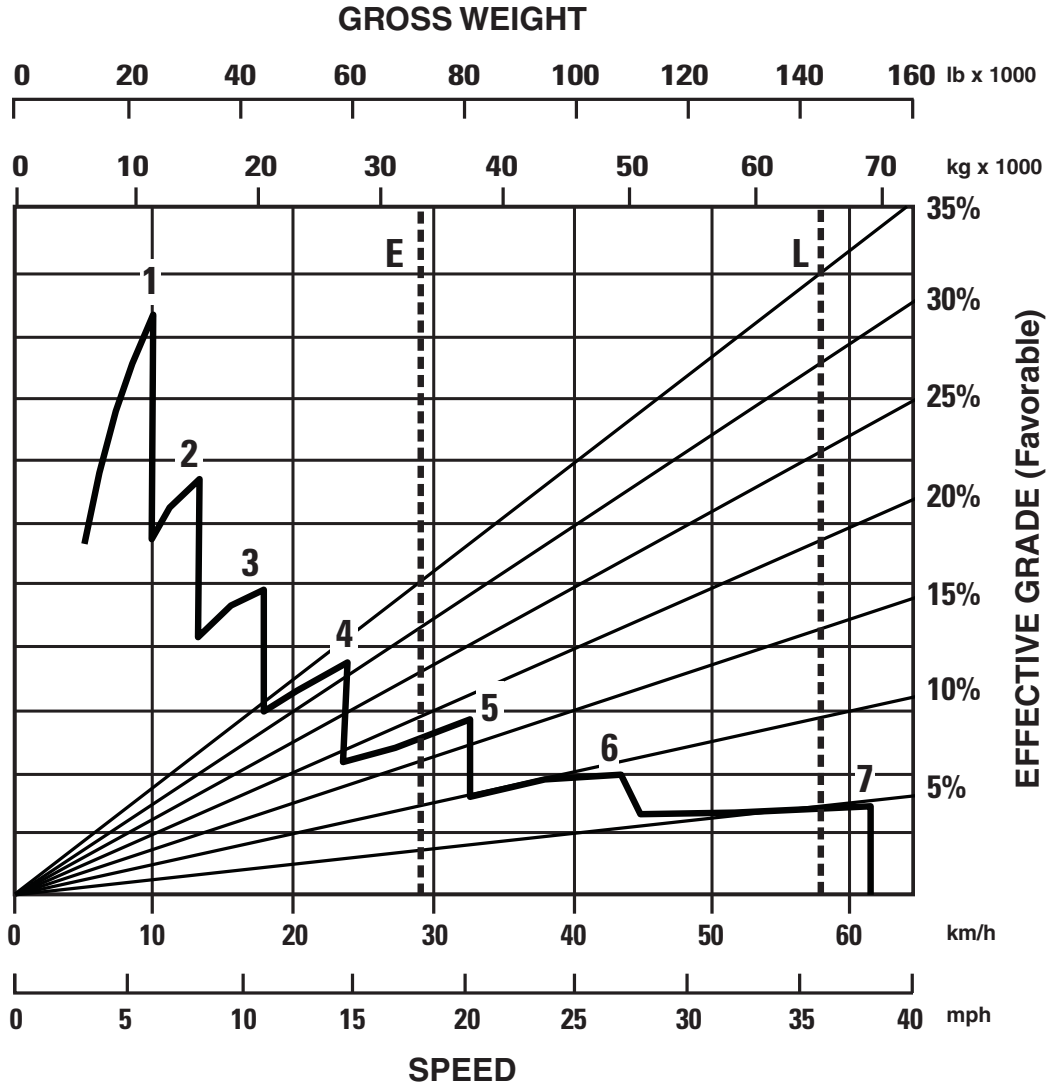

KEY

- 1 — 1st Gear
- 2 — 2nd Gear
- 3 — 3rd Gear
- 4 — 4th Gear
- 5 — 5th Gear
- 6 — 6th Gear
- 7 — 7th Gear

KEY

- E — Empty 32 473 kg (71,591 lb)
- L — Loaded 65 173 kg (143,682 lb)



**Articulated Trucks**

**735B Series Rimpull-Speed-Gradeability**

- 26.5R25 Tires
- Tier 2

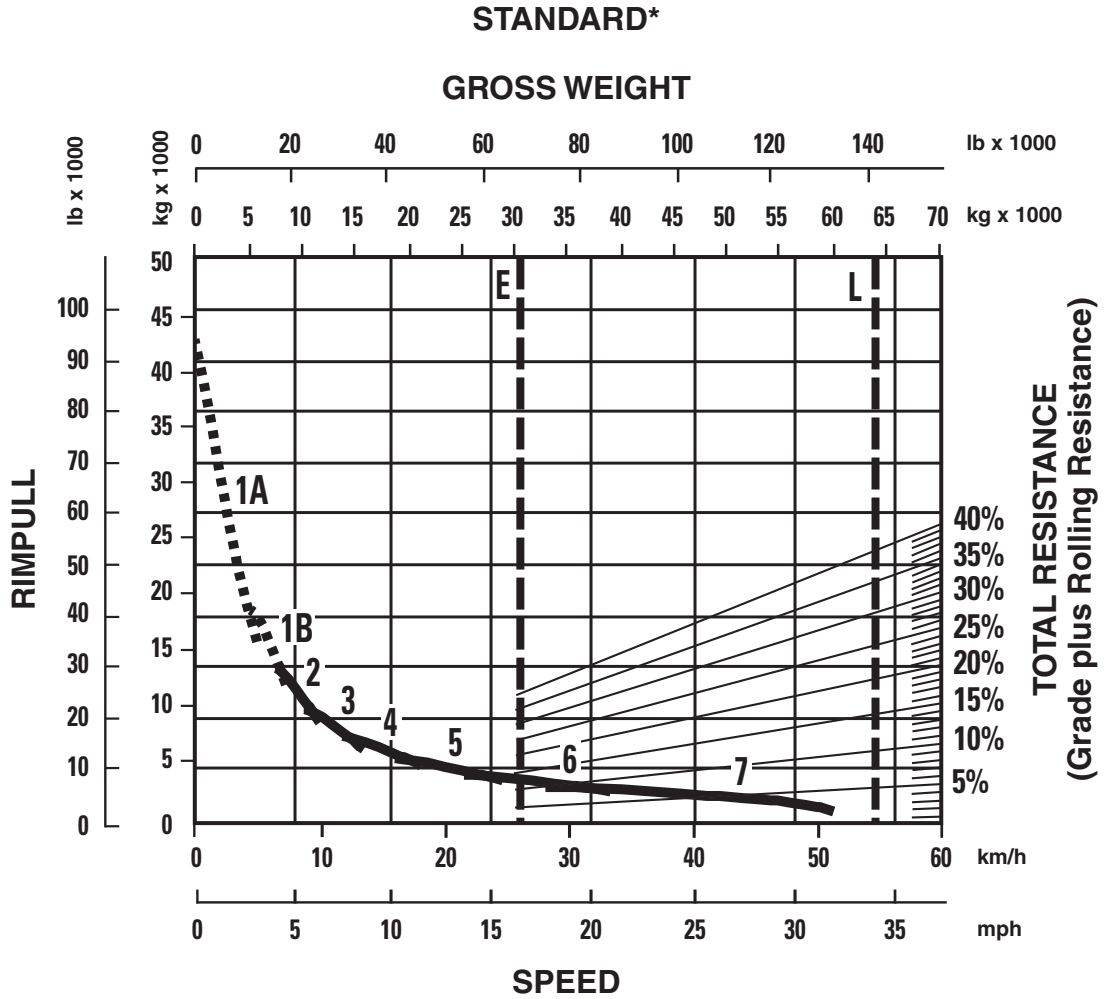

**KEY**

- 1A — 1st Gear (Converter Drive)
- 1B — 1st Gear (Direct Drive)
- 2 — 2nd Gear
- 3 — 3rd Gear
- 4 — 4th Gear
- 5 — 5th Gear
- 6 — 6th Gear
- 7 — 7th Gear

**KEY**

- E — Empty 32 206 kg (71,002 lb)
- L — Loaded 64 906 kg (143,093 lb)

\*At sea level.

735B Series Brake/Retarder Performance Curve

Articulated Trucks

● 26.5R25 Tires

● Tier 2

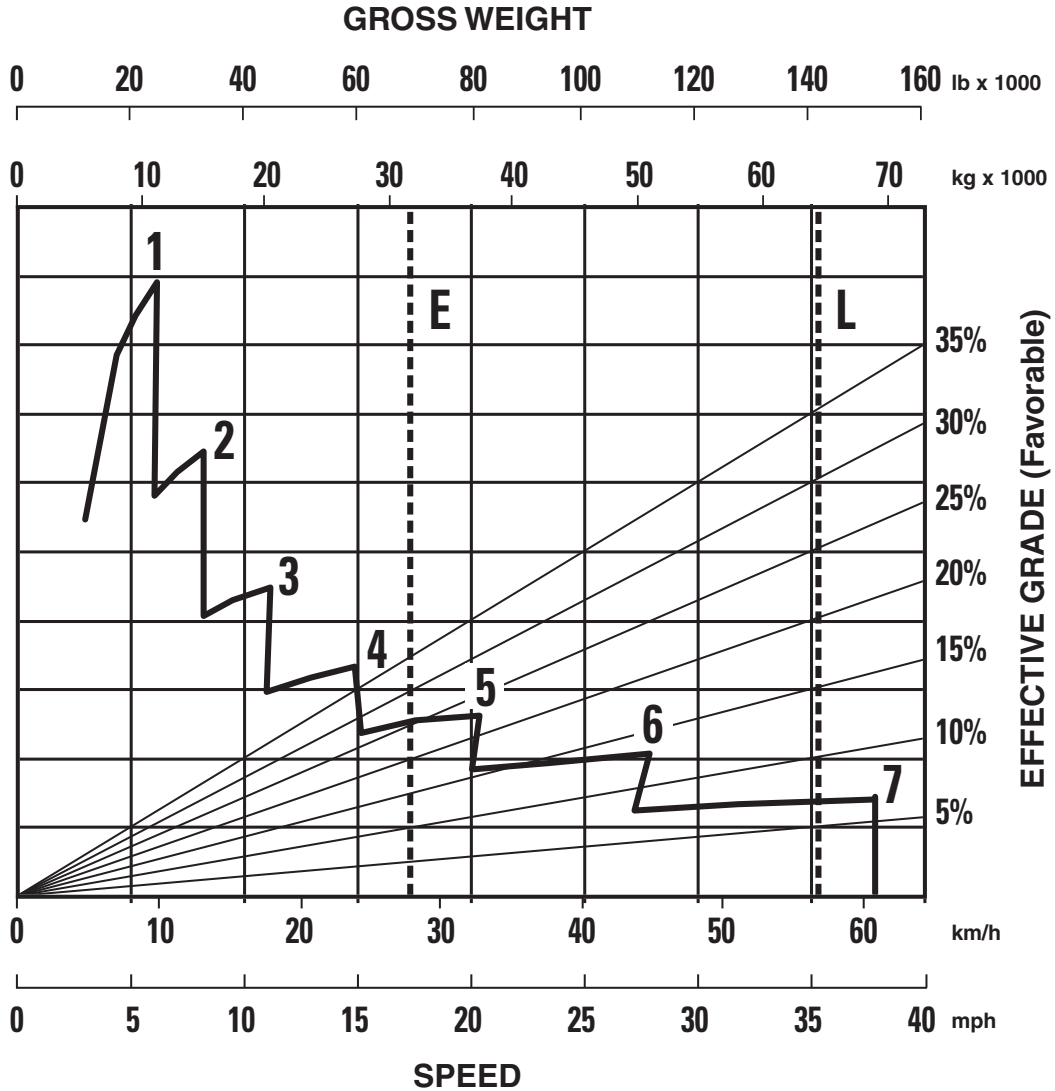

10

KEY

- 1 — 1st Gear
- 2 — 2nd Gear
- 3 — 3rd Gear
- 4 — 4th Gear
- 5 — 5th Gear
- 6 — 6th Gear
- 7 — 7th Gear

KEY

- E — Empty 32 206 kg (71,002 lb)
- L — Loaded 64 906 kg (143,093 lb)

# Articulated Trucks

## 735B Series Travel Time — Loaded/Empty

- 26.5R25 Tires
- Preliminary Information

### LOADED

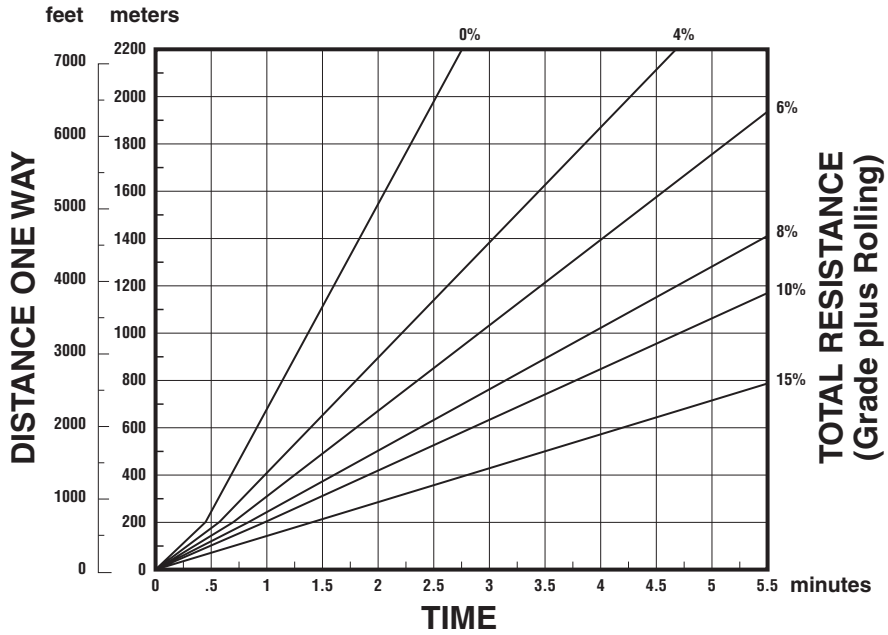

### EMPTY

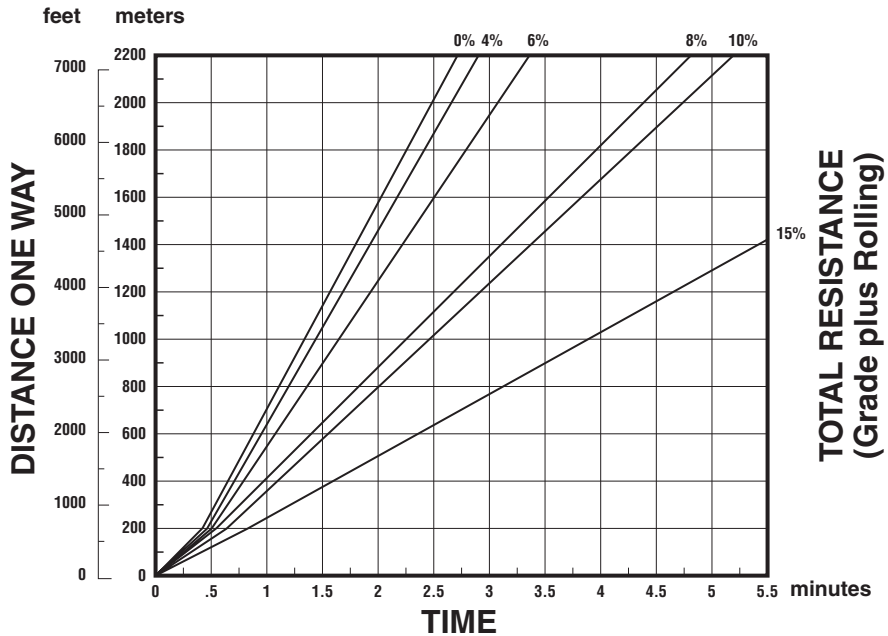

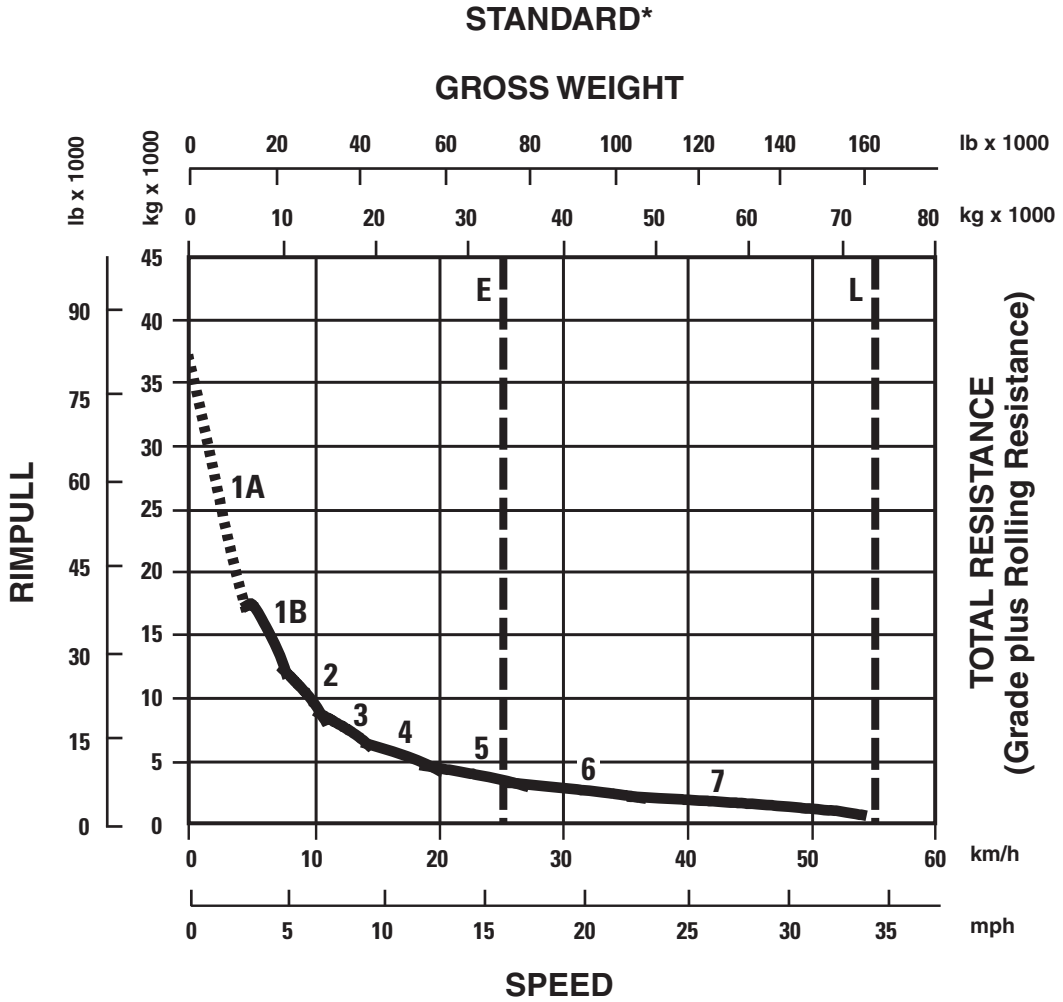

**KEY**

- 1A — 1st Gear (Converter Drive)
- 1B — 1st Gear (Direct Drive)
- 2 — 2nd Gear
- 3 — 3rd Gear
- 4 — 4th Gear
- 5 — 5th Gear
- 6 — 6th Gear
- 7 — 7th Gear

**KEY**

- E — Empty 34 393 kg (75,824 lb)
- L — Loaded 73 975 kg (163,087 lb)

\*At sea level.

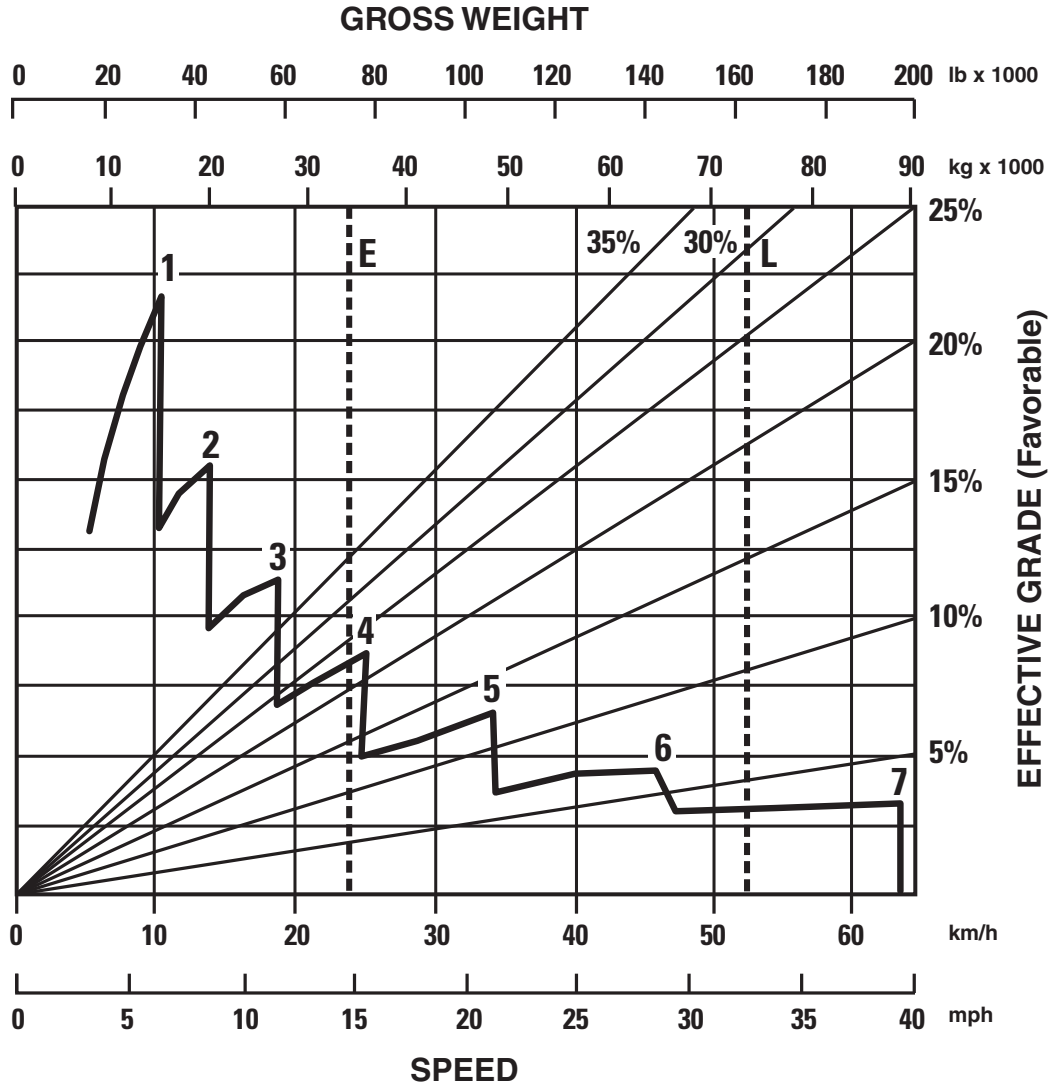

- KEY**
- 1 — 1st Gear
  - 2 — 2nd Gear
  - 3 — 3rd Gear
  - 4 — 4th Gear
  - 5 — 5th Gear
  - 6 — 6th Gear
  - 7 — 7th Gear

- KEY**
- E — Empty 34 393 kg (75,824 lb)
  - L — Loaded 73 975 kg (163,087 lb)

STANDARD\*

GROSS WEIGHT

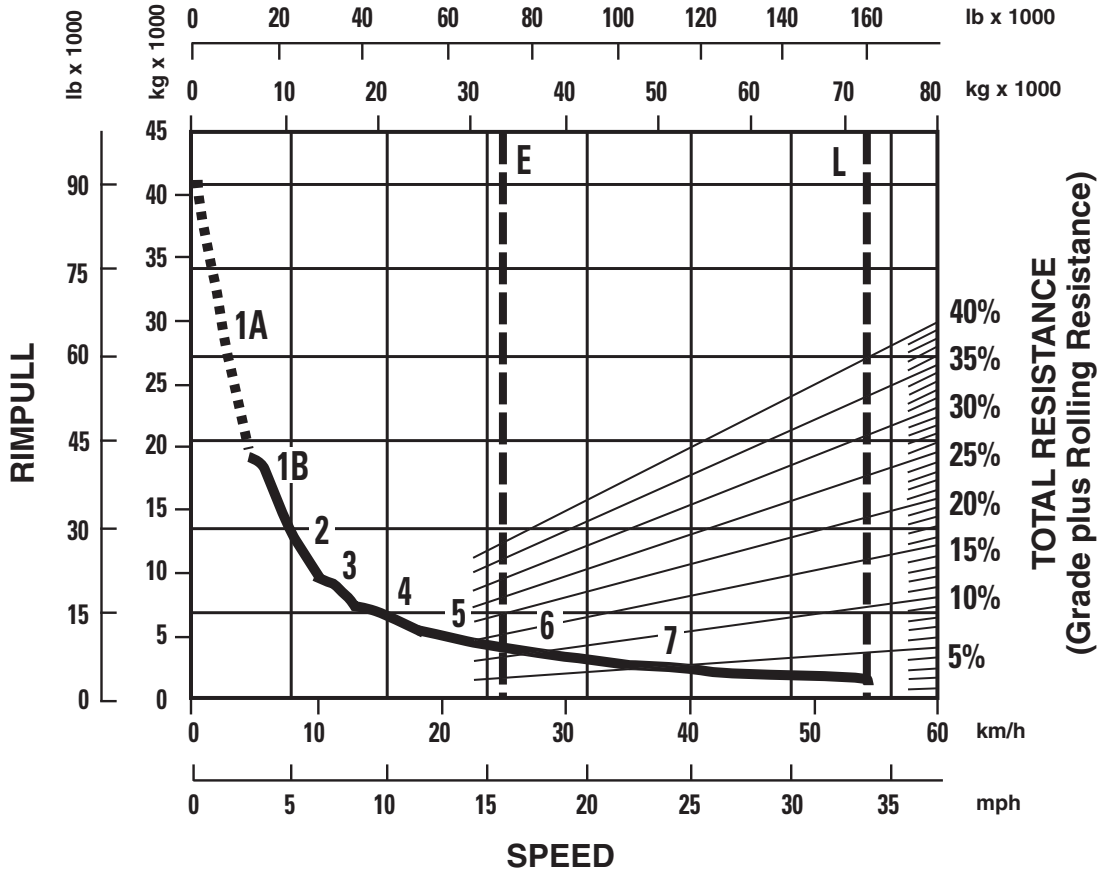

10

KEY

- 1A — 1st Gear (Converter Drive)
- 1B — 1st Gear (Direct Drive)
- 2 — 2nd Gear
- 3 — 3rd Gear
- 4 — 4th Gear
- 5 — 5th Gear
- 6 — 6th Gear
- 7 — 7th Gear

KEY

- E — Empty 34 127 kg (75,237 lb)
- L — Loaded 73 709 kg (162,500 lb)

\*At sea level.

# Articulated Trucks

## 740B Series Brake/Retarder Performance Curve

- 29.5R25 Tires
- Tier 2

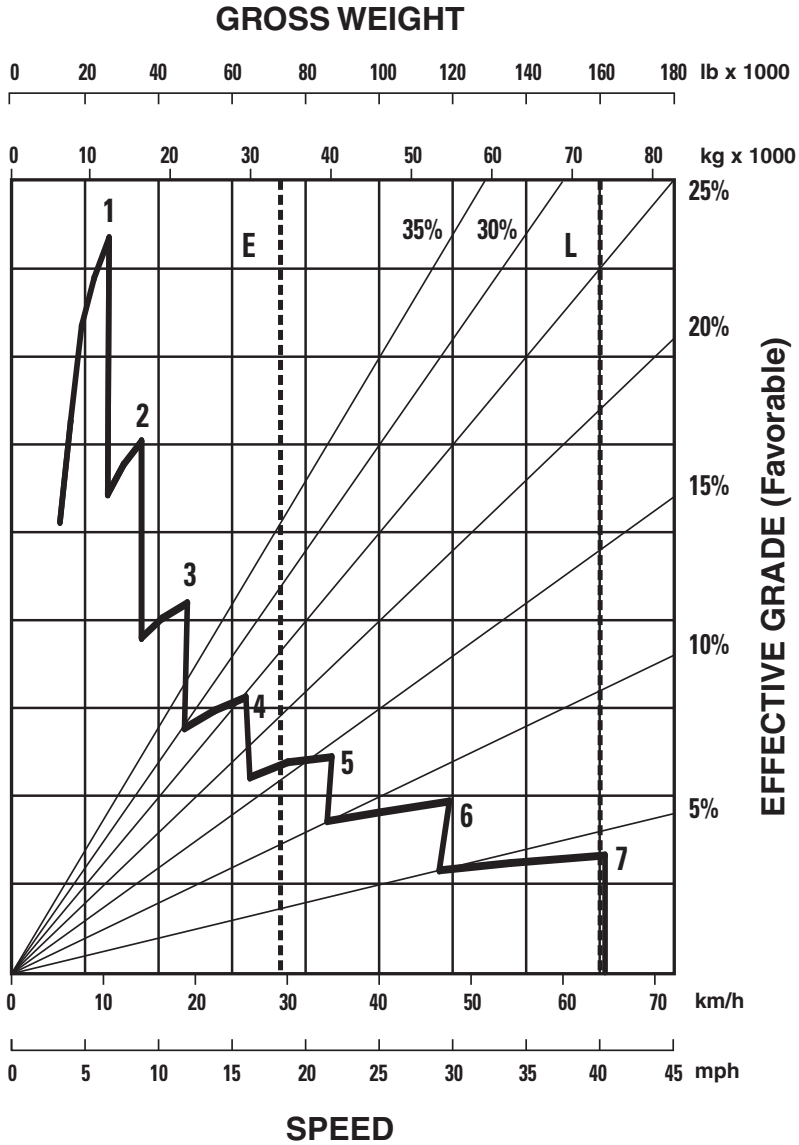

**KEY**

- 1 — 1st Gear
- 2 — 2nd Gear
- 3 — 3rd Gear
- 4 — 4th Gear
- 5 — 5th Gear
- 6 — 6th Gear
- 7 — 7th Gear

**KEY**

- E — Empty 34 127 kg (75,237 lb)
- L — Loaded 73 709 kg (162,500 lb)

**LOADED**

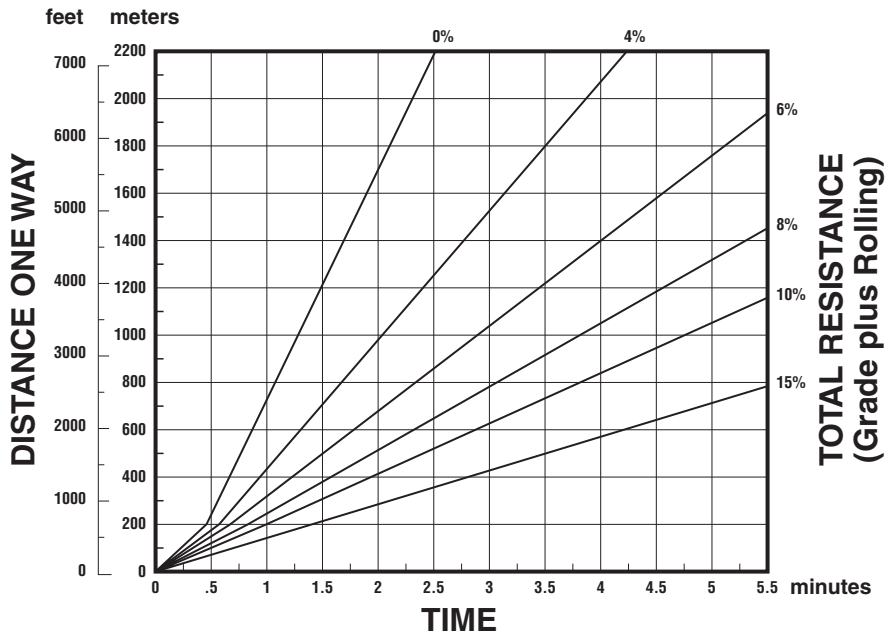

**EMPTY**

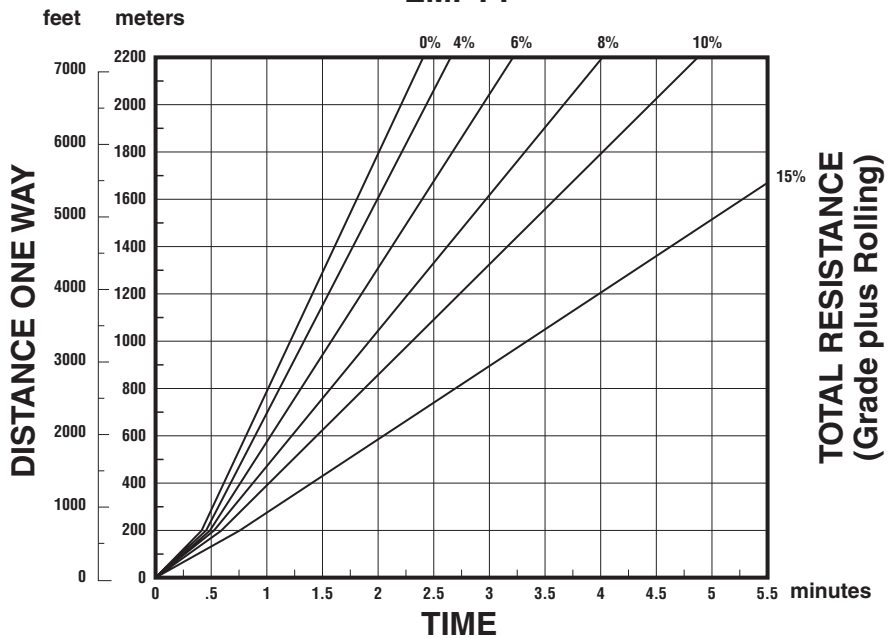



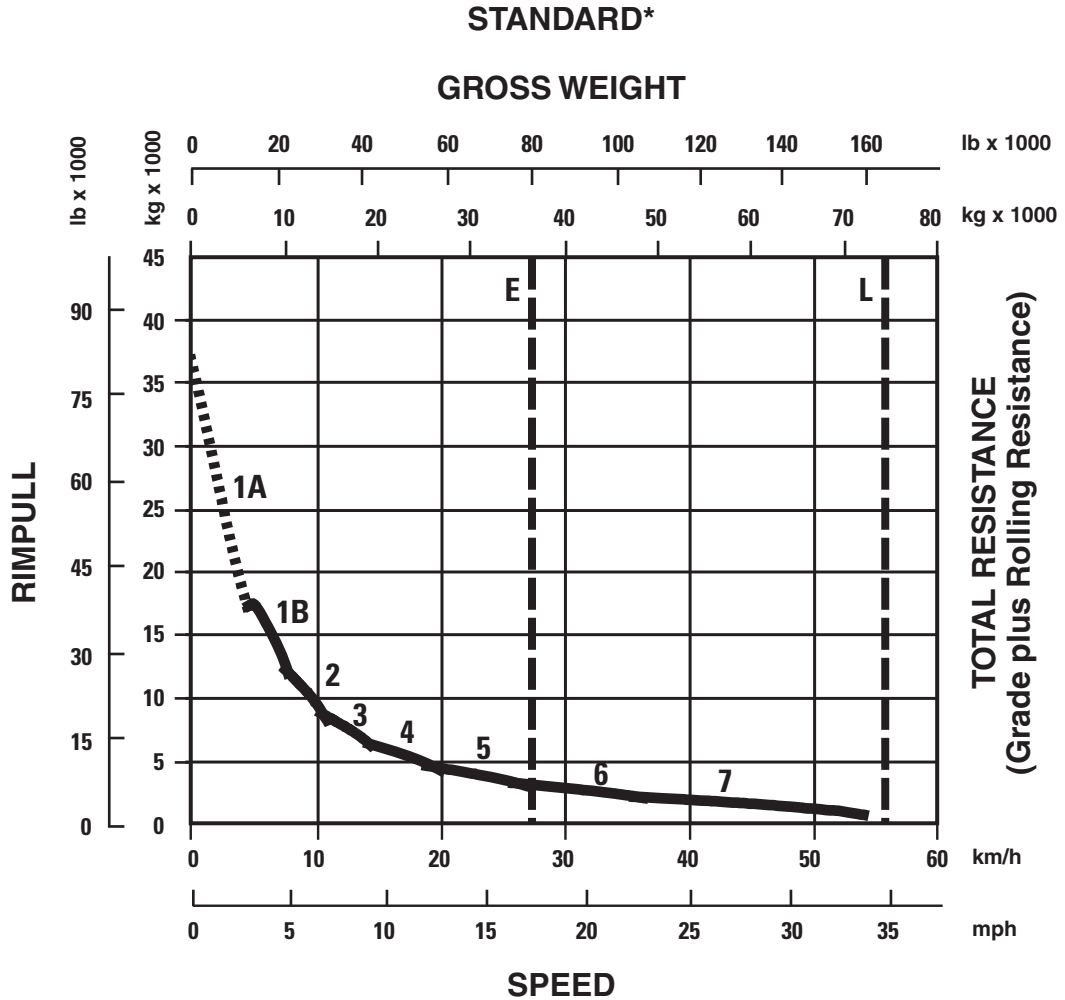

**KEY**

- 1A — 1st Gear (Converter Drive)
- 1B — 1st Gear (Direct Drive)
- 2 — 2nd Gear
- 3 — 3rd Gear
- 4 — 4th Gear
- 5 — 5th Gear
- 6 — 6th Gear
- 7 — 7th Gear

**KEY**

- E — Empty 36 895 kg (81,340 lb)
- L — Loaded 74 895 kg (165,115 lb)

\*At sea level.

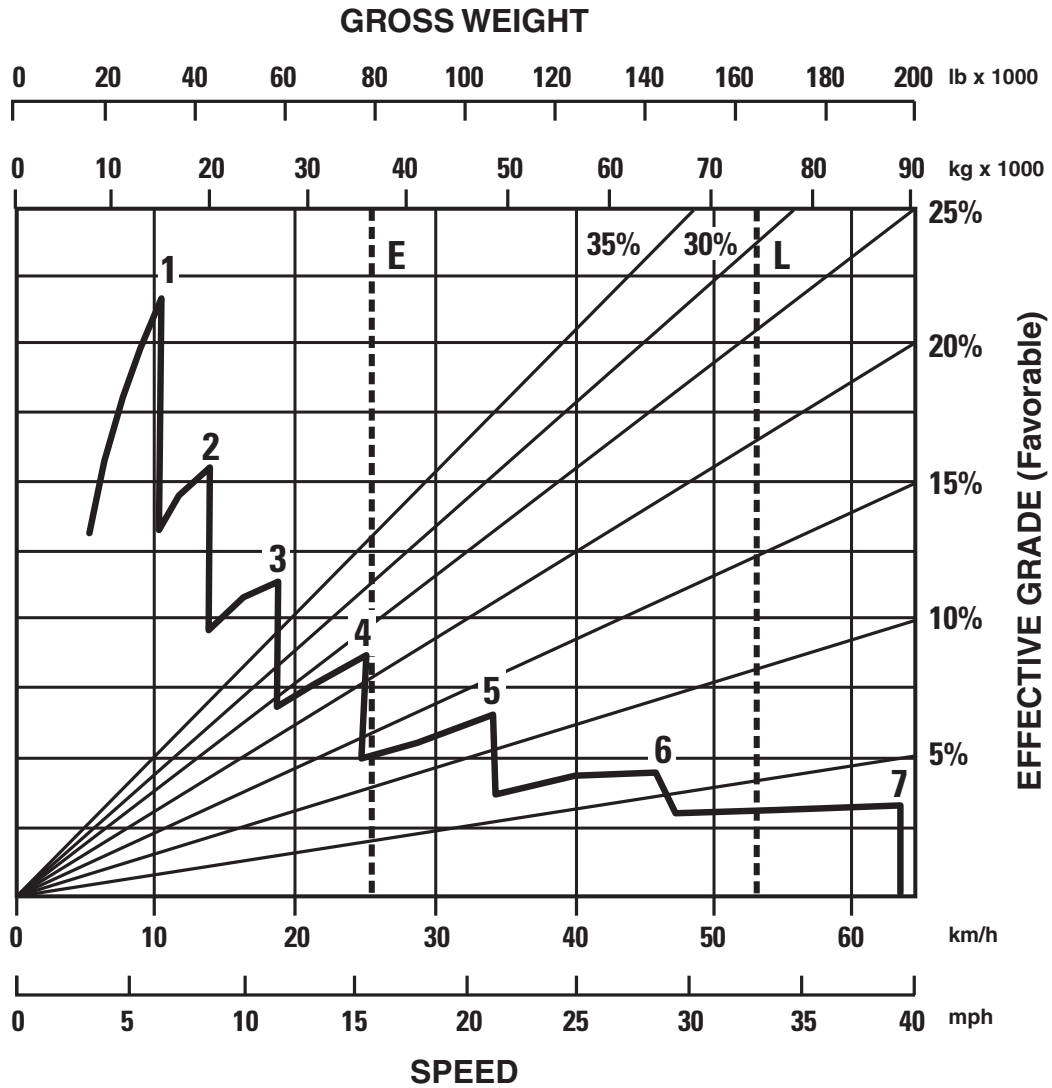

**KEY**

- 1 — 1st Gear
- 2 — 2nd Gear
- 3 — 3rd Gear
- 4 — 4th Gear
- 5 — 5th Gear
- 6 — 6th Gear
- 7 — 7th Gear

**KEY**

- E — Empty 36 895 kg (81,340 lb)
- L — Loaded 74 895 kg (165,115 lb)

# Articulated Trucks

740B EJ Series Rimpull-Speed-Gradeability

● 29.5R25 Tires

● Tier 2

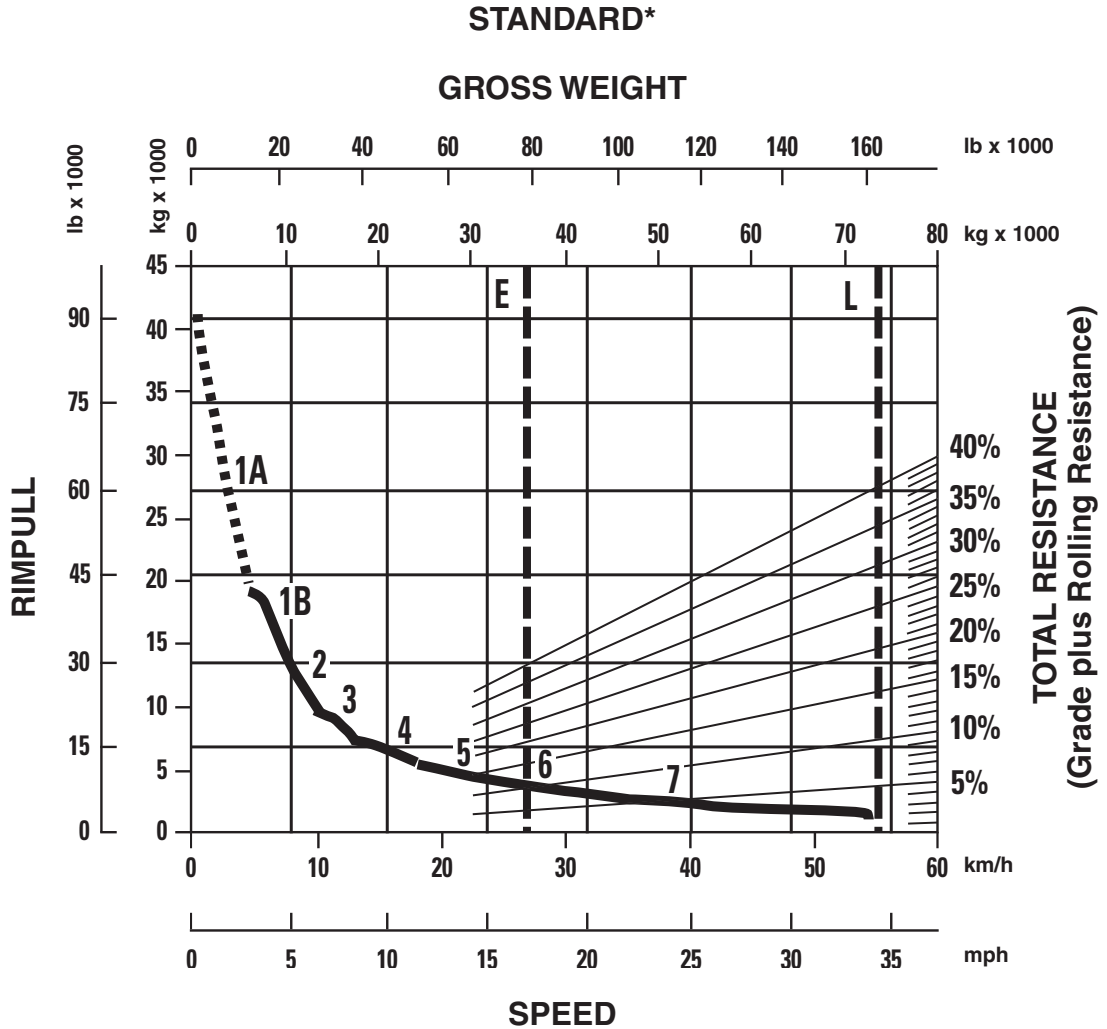

**KEY**

- 1A — 1st Gear (Converter Drive)
- 1B — 1st Gear (Direct Drive)
- 2 — 2nd Gear
- 3 — 3rd Gear
- 4 — 4th Gear
- 5 — 5th Gear
- 6 — 6th Gear
- 7 — 7th Gear

**KEY**

- E — Empty 36 629 kg (80,753 lb)
- L — Loaded 74 629 kg (164,529 lb)

\*At sea level.

● 29.5R25 Tires

● Tier 2

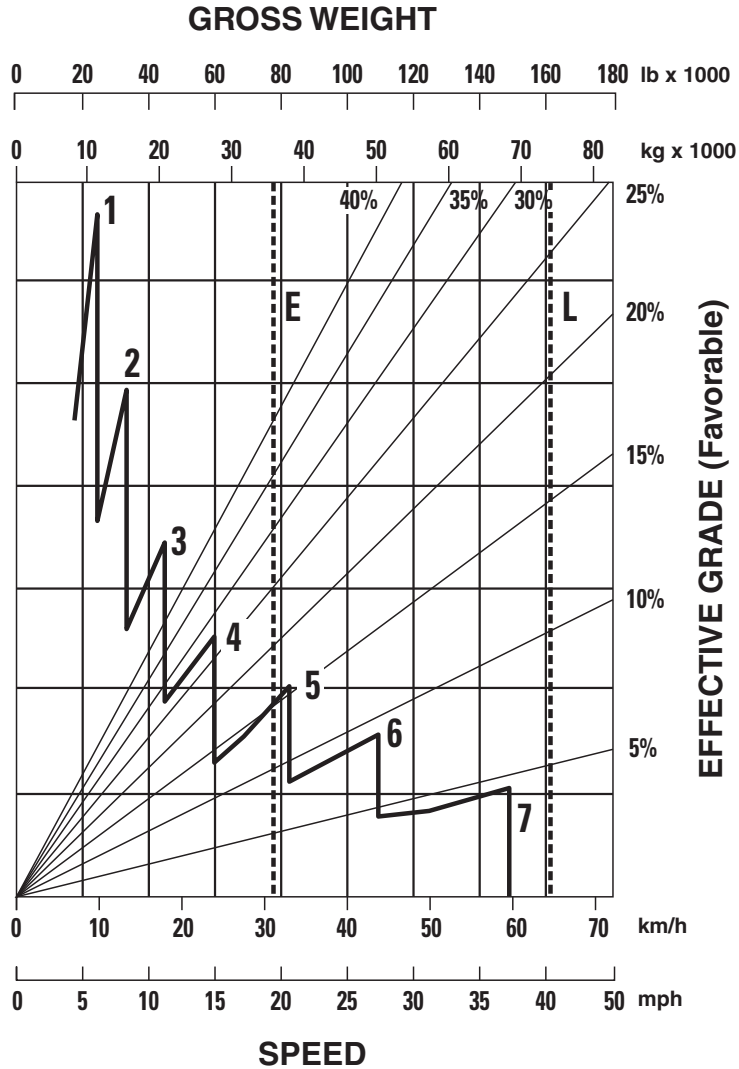

10

**KEY**

- 1 — 1st Gear
- 2 — 2nd Gear
- 3 — 3rd Gear
- 4 — 4th Gear
- 5 — 5th Gear
- 6 — 6th Gear
- 7 — 7th Gear

**KEY**

- E — Empty 36 629 kg (80,753 lb)
- L — Loaded 74 629 kg (164,529 lb)



# WHEEL DOZERS SOIL COMPACTORS

## CONTENTS

### WHEEL DOZERS

Features	11-1
Specifications	11-2
Travel Speeds	11-4
Rimpull	11-4
Machine Selection	11-6
Counterweights and Ballast	11-6
Tire Selection and Maintenance	11-6
Bulldozer Specifications	11-8
Work Tools	11-9

### SOIL COMPACTORS

Features	11-11
Specifications	11-12
Rimpull	11-13
Compaction Fundamentals	11-14
Compactor Types and Zones of Application	11-15
Estimating Production (Example Problem)	11-16
Production Table	11-17
Bulldozer Specifications	11-17
Ground Contact Pressures	11-18

### LANDFILL COMPACTORS (See Section 25)

## WHEEL DOZERS

### Features:

- **Reliable Cat power train:** four-stroke-cycle diesel with adjustment-free fuel system ... full power shift with single lever on-the-go shifting.
- **Articulated frame steering** with hinge point midway between front and rear axles ... short turning radius, long wheelbase ... rear and front wheels track at all times.
- **Machine balance** ... equal weight distribution on axles when blading.
- **All dozer functions**, including tip and tilt, hydraulically controlled from operator's seat.



MODEL	814F2		824H		834H	
Flywheel Power	173 kW	<b>232 hp</b>	264 kW	<b>354 hp</b>	372 kW	<b>498 hp</b>
Operating Weight*	21 713 kg	<b>47,877 lb</b>	28 724 kg	<b>63,325 lb</b>	47 106 kg	<b>103,849 lb</b>
Engine Model	<b>C9 ACERT</b>		<b>C15 ACERT</b>		<b>C18 ACERT</b>	
Rated Engine RPM	<b>2100</b>		<b>1800</b>		<b>1800</b>	
No. Cylinders	<b>6</b>		<b>6</b>		<b>6</b>	
Displacement	8.8 L	<b>537 in<sup>3</sup></b>	15.2 L	<b>928 in<sup>3</sup></b>	18.1 L	<b>1104 in<sup>3</sup></b>
Speeds:						
Forward	<b>4</b>		<b>4</b>		<b>4</b>	
Reverse	<b>4</b>		<b>4</b>		<b>3</b>	
Top Speed Forward	30.9 km/h	<b>19.2 mph</b>	32.1 km/h	<b>20 mph</b>	38.5 km/h	<b>23.9 mph</b>
Turning Circle with Blade	7.17 m	<b>23'6"</b>	14.6 m	<b>48'0"</b>	17.6 m	<b>57'9"</b>
Standard Tire Size	<b>23.5-25, 12 PR (L-2)</b>		<b>29.5R25 (L-3)</b>		<b>35/65-R33, 24 PR (L-4)</b>	
Fuel Tank Refill Capacity	446 L	<b>118 U.S. gal</b>	672 L	<b>178 U.S. gal</b>	793 L	<b>209 U.S. gal</b>
GENERAL DIMENSIONS:						
Height (to top of ROPS)	3.3 m	<b>10'8"</b>	3.7 m	<b>12'1"</b>	4.09 m	<b>13'5"</b>
Height (stripped top)**	2.4 m	<b>7'9"</b>	2.6 m	<b>8'5"</b>	3.15 m	<b>10'4"</b>
Wheel Base	3.35 m	<b>11'0"</b>	3.7 m	<b>12'1"</b>	4.55 m	<b>14'11"</b>
Overall Length with Dozer	6.9 m	<b>22'8"</b>	8.2 m	<b>27'0"</b>	10.42 m	<b>34'2"</b>
Width (over standard tires)	2.8 m	<b>9'2"</b>	3.28 m	<b>10'9"</b>	3.47 m	<b>11'5"</b>
Ground Clearance	366 mm	<b>14.4"</b>	400 mm	<b>15.7"</b>	540 mm	<b>21"</b>
STRAIGHT BULLDOZER:						
Width	3.6 m	<b>11'8"</b>	4.51 m	<b>14'8"</b>	5.07 m	<b>16'8"</b>
Height	1.1 m	<b>3'6"</b>	1.23 m	<b>4'0"</b>	1.46 m	<b>4'9"</b>
Capacity	2.73 LCM	<b>3.6 LCY</b>	4.67 LCM	<b>6.11 LCY</b>	7.87 LCM***	<b>10.3 LCY***</b>
Ground Clearance Below Skid Shoe	718 mm	<b>2'4"</b>	955 mm	<b>3'1.6"</b>	1390 mm	<b>4'7"</b>
Depth of Cut	528 mm	<b>20.8"</b>	430 mm	<b>16.9"</b>	455 mm	<b>17.9"</b>
Tilt Adjustment	795 mm	<b>2'6"</b>	1.18 m	<b>3'9"</b>	1.48 m	<b>4'10"</b>
Tip Adjustment	<b>15°</b>		<b>22.4°</b>		<b>21°</b>	
Lift Speed	0.4 m/sec	<b>1.3 ft/sec</b>	0.46 m/sec	<b>1.46 ft/sec</b>	0.81 m/sec	<b>2.66 ft/sec</b>

\*Operating Weight includes straight dozer, (U-blade on 834H) lubricants, coolant, ROPS cab, full fuel tank and operator. 75% CaCl<sub>2</sub> in all tires adds the following weight to each model: 814F2 — 2342 kg (**5164 lb**), 824H — 4296 kg (**9472 lb**), 834H — 5719 kg (**12,608 lb**).

\*\*Height (stripped top) — without ROPS, exhaust, seat back or easily removed encumbrances.

\*\*\*Capacity of 834H U-Blade is 11.16 LCM (**14.6 LCY**).



MODEL	844H		854K	
Flywheel Power	468 kW	627 hp	597 kW	801 hp
Operating Weight*	70 815 kg	156,120 lb	98 100 kg	216,273 lb
Engine Model	C27		C32 ACERT	
Rated Engine RPM	2000		1750	
No. Cylinders	12		12	
Displacement	27.1 L	1666 in <sup>3</sup>	32.1 L	1959 in <sup>3</sup>
Speeds:				
Forward	3		3	
Reverse	3		3	
Top Speed Forward	21 km/h	13 mph	21.2 km/h	13.2 mph
Turning Circle with Blade	21.73 m	71'4"	23.4 m	76'9"
Standard Tire Size	45/65-R39, PR (L-4)		45/65-R45 (L-4)	
Fuel Tank Refill Capacity	1016 L	268 U.S. gal	1562 L	413 U.S. gal
GENERAL DIMENSIONS:				
Height (to top of ROPS)	5.023 m	16'6"	5590 mm	18'3"
Height (stripped top)**	3.8 m	12'6"	5234 mm	17'2"
Wheel Base	4.6 m	15'1"	5890 mm	19'3"
Overall Length with Dozer	10.94 m	35'9"	13 405 mm	44'0"
Width (over standard tires)	4.37 m	14'4"	3556 mm	11'8"
Ground Clearance	431 mm	1'5"	691 mm	27"
SEMI-U DOZER:				
Width	5.278 m	17'4"	6321 mm	20'8"
Height	1.877 m	6'2"	5590 mm	18'3"
Capacity	16.1 m <sup>3</sup>	21.1 yd <sup>3</sup>	25.4 m <sup>3</sup>	33.1 yd <sup>3</sup>
Ground Clearance Below Skid Shoe	1372 mm	4'6"	691 mm	27"
Depth of Cut	466 mm	18"	398 mm	1'3"
Tilt Adjustment	830 mm	2'9"	1165 mm	3'8"
Tip Adjustment		13°		15°
Lift Speed	0.353 m/sec	1.2 ft/sec	0.310 m/sec	1.05 ft/sec

\*Operating Weight includes Semi-U, coolant, ROPS cab, full fuel tank and operator. If 75% CaCl<sub>2</sub> is added to all four tires, the weight increases by 11 112 kg (24,500 lb) on the 844H and 12 144 kg (26,770 lb) on the 854K.

\*\*Height (stripped top) — without ROPS, exhaust, seat back or easily removed encumbrances.



MODEL	814F2		824H		834H*		844H*		854K*	
FORWARD										
GEAR	km/h	mph	km/h	mph	km/h	mph	km/h	mph	km/h	mph
1	5.7	3.6	6.1	3.8	6.8	4.2	7.0	4.4	7.1	4.4
2	10.2	6.4	10.5	6.5	11.6	7.2	12.2	7.6	12.4	7.7
3	17.9	11.2	18.3	11.4	20.3	12.6	21.0	13.0	21.1	13.1
4	31.0	19.3	32.1	20.0	35.4	22.0	—	—	—	—
REVERSE										
GEAR										
1	6.5	4.1	6.9	4.3	6.8	4.2	7.7	4.6	7.7	4.8
2	11.6	7.3	12.0	7.5	12.2	7.6	13.4	8.4	13.5	8.4
3	20.4	12.7	20.8	13.0	21.4	13.3	23.0	14.3	23.5	14.6
4	34.9	21.8	36.6	22.7	—	—	—	—	—	—

\*2% rolling resistance.

814F2

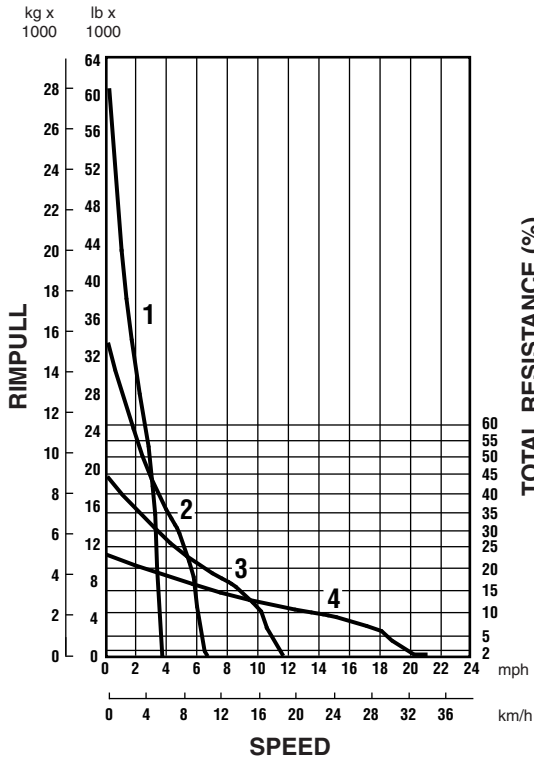

824H

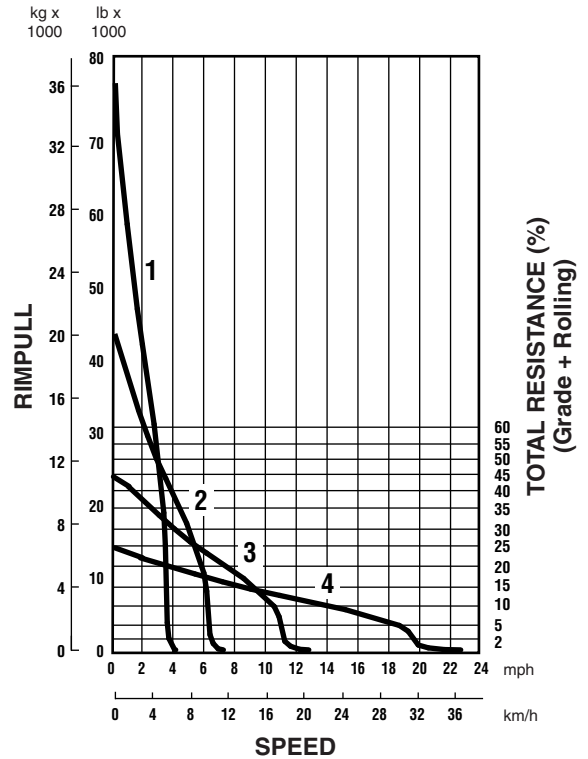

KEY  
1 - 1st Gear  
2 - 2nd Gear  
3 - 3rd Gear  
4 - 4th Gear

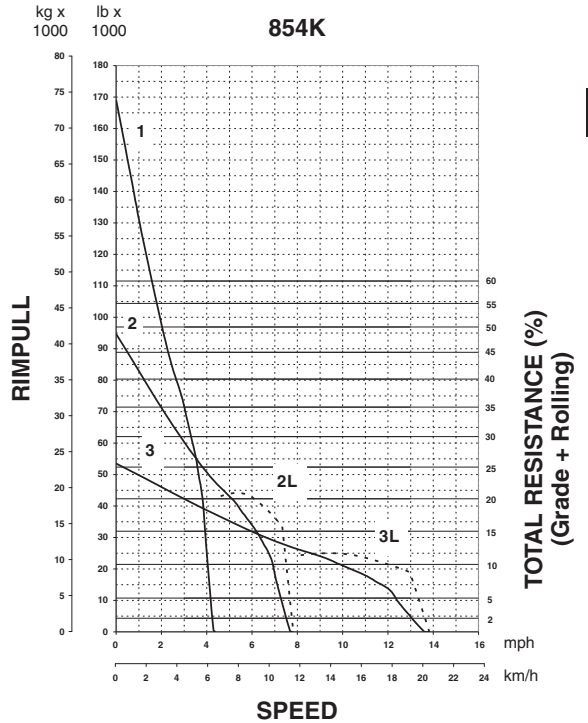
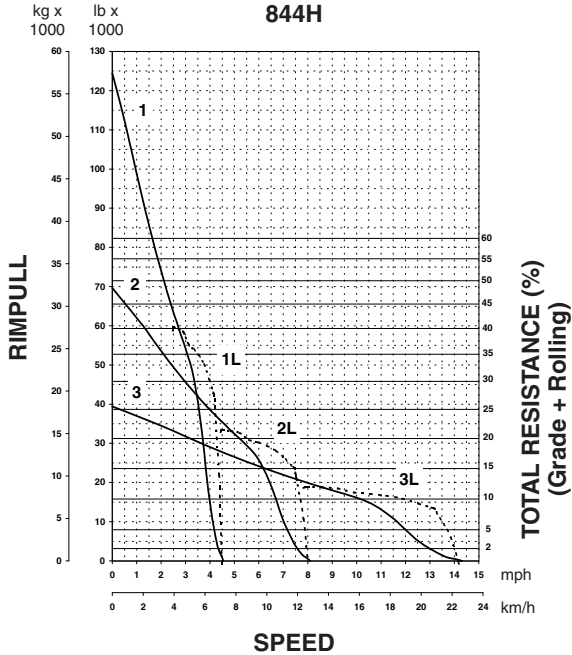
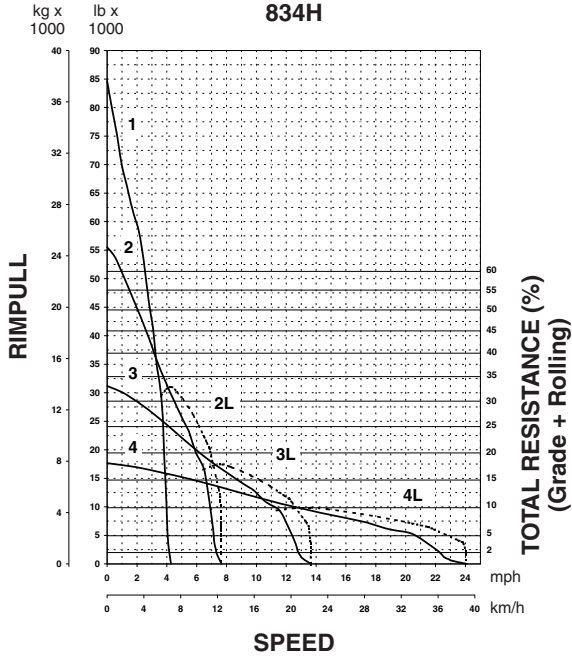

## CONSIDERATIONS IN MACHINE SELECTION

The following factors should be considered when comparing wheels vs. tracks:

### Traction

You can figure coefficient of traction, depending on underfoot conditions, from the Table Section in this book.

Wheels — up to 0.65 (in quarry pit with good floor)

Track — up to 0.90 (in soils permitting grouser penetration)

Usable Rimpull = Machine Weight × Coefficient of Traction

### Speed

Wheels — travel speeds up to three times higher than track.

### Maneuverability

Articulated steering and good visibility give wheel tractors high maneuverability.

### Cost

See Owning and Operating Costs section. Tire vs. undercarriage costs can often be the deciding factor in selecting wheels or tracks.

### Compaction

Ground Pressure:

Wheels — from 241 kPa (35 psi) to 310 kPa (45 psi)

Tracks — from 82 kPa (12 psi) to 97 kPa (14 psi)

### Application

*Utility ...* mobility, maneuverability and good speed suit wheel tractors for yard and stockpile work and for clean-up around shovels. Lower maintenance costs may be realized in certain soils that can be highly abrasive to track-type undercarriages.

*Coal pile ...* recommend wheel tractors in this application when following conditions are present:

- Long push distances
- Need for good material spread
- High degree of compaction desired

*Production Dozing ...* a wheel tractor should be considered in the following conditions:

- Long push distances
- Loose soils, little or no rock
- Level or downhill work
- Good underfoot conditions

*Pushloading Scrapers ...* a wheel tractor should be considered in the following conditions:

- Thin scraper cut
- Good underfoot conditions — no rock
- Higher push speeds

*Chip and Coal Scoops ...* may adversely affect performance and/or reliability, particularly when adverse grades are encountered.

## COUNTERWEIGHTS AND BALLAST

For each specific application, there is a correct machine weight for proper balancing of traction, flotation, mobility and response.

- Low machine weight may increase tire slipping and wear, but improves flotation, mobility and machine response.
- High machine weight increases traction, but decreases mobility and response.

The machine weight is optimum for the operating conditions when wheel slipping barely occurs in the gear being used. Weight distribution under operating conditions should then be approximately equal between the wheels to balance power to each axle.

### Application

Lower machine weight is usually required for typical second gear applications, such as fill spreading, stockpiling, road maintenance, towing compactors and shovel cleanup.

Higher machine weight is usually required for such typical first gear applications as heavy dozing and pushloading.

### Tire Ballast

A solution of calcium chloride and water is recommended for tire ballast. It has the advantage of low cost with simple quick adjustment to suit working conditions.

## TIRE SELECTION & MAINTENANCE

Requirements of traction, flotation and tire life are met by a choice of tire size, tread design and inflation pressure.

### Tire Width

For good conditions with little rolling resistance on surfaces where flotation is no problem, a narrower tire may be most economical. It may also be considered in muddy conditions in which the mud can be penetrated to reach firm earth underneath.

Where flotation problems and increased rolling resistance are encountered, wider tires are recommended. The greater contact area and shallower penetration increases flotation.

### Tire Size

Larger optional tires will also improve flotation in soft conditions. With larger diameter, rimpull will be reduced which may be desirable to help control wheel spin.

**Traction Tread (L-2)** tire's penetration ability provides improved traction under some soil conditions.

**Rock Tread (L-3)** offers improved traction and a more cut resistant rubber compound than the L-2. It provides more rubber at the ground with the same footprint and reduces tire penetration under abrasive conditions. Recommended on any hard smooth surface such as rock, concrete or compacted earth.

**Rock — Deep Tread (L-4)** provides 50% more tread depth, thicker undertread and sidewall with increased tire life when compared to the L-3 tire. Recommended in rock conditions where sharp fragments cause high tire wear or sudden failures.

**Rock — Extra Deep Tread (L-5)** provides 150% more tread depth when compared to the L-3 tire. Intended for severe rock conditions with extreme penetration hazards.

**Chains** should be considered in severe applications where extra tread tires still give unsatisfactory life. Operating costs vary greatly depending on application, underfoot conditions, wheel spin and chain maintenance. Under normal rock operating conditions (short cycle, low average speed and minimum wheel spin) the maximum estimated chain life is about 2000 hours. Before installing chains, carefully weigh their overall economics against known tire costs. Chains are not recommended with new rock extra tread tires but can extend the life of a used tire. Always check clearance around tires before using chains.

Major applications where chains can be considered include:

- stripping rock or rocky soils
- clean-up work around rock loading shovels
- any application where underfoot conditions cause excessive tire wear.

### Inflation Pressure

In average operating conditions the recommended inflation pressure prevents excessive deflection and minimizes tire rollover on side slopes.

### Over-inflation

Reduces amount of tread contact with ground and provides less flotation. Over-inflation causes center of tread to wear faster and increases the chance of cuts and impact breaks.

### Under-inflation

Can cause permanent tire damage in the form of flex breaks, radial cracks, and tread or ply separation. On jobs where wrinkling and bead rollover *are not* apparent, inflation pressure may be reduced to a minimum of:

*Bias Ply* — 170 kPa (25 psi) on 35/65-33  
 170 kPa (25 psi) on 29.5-25  
 170 kPa (25 psi) on 26.5-25  
 170 kPa (25 psi) on 23.5-25

*Radial* — 310 kPa (45 psi) on 35/65-R33  
 310 kPa (45 psi) on 29.5-R25  
 205 kPa (30 psi) on 26.5-R25  
 240 kPa (35 psi) on 23.5-R25

Reduced pressure will:

- Increase flotation and traction in sand.
- Improve envelopment characteristics to reduce sudden death failure on rock jobs.
- Provide better tread wear by reducing contact pressure between tire and ground.

Consult your tire manufacturer before changing tire pressures.

MODEL	814F2		824H		824H	
Type	Straight		Straight		SU-Blade	
Capacity**	2.66 m <sup>3</sup>	3.5 yd <sup>3</sup>	4.67 m <sup>3</sup>	6.11 yd <sup>3</sup>	6.88 m <sup>3</sup>	9.0 yd <sup>3</sup>
Weight, Dozer*	3740 kg	8245 lb	5136 kg	11,323 lb	—	
General Dimensions (Tractor & Dozer)						
Length	6.9 m	22'6"	8.2 m	26'9"	—	
Width	3.6 m	11'8"	4.51 m	14'8"	4.44 m	14'7"
Blade:						
Width (including std. end bits)	3.6 m	11'8"	4.51 m	14'8"	4.44 m	14'7"
Height	1100 mm	3'6"	1229 mm	4'0"	1584 mm	5'2"
Max. Digging Depth	528 mm	20.8"	430 mm	16.9"	542 mm	21"
Ground Clearance @ Full Lift Under Skid Plate	718 mm	2'4"	955 mm	3'1.6"	996 mm	3'3"
Tilt Adjust. from Horizontal	795 mm	2'6"	1180 mm	3'9"	1166 mm	3'10"
Total Tip Adjustment	15°		22.4°		—	

MODEL	824H		824H		834H	
Type	U-Blade		Extreme Service U-Blade		Straight	
Capacity**	6.88 m <sup>3</sup>	9.0 yd <sup>3</sup>	6.88 m <sup>3</sup>	9.0 yd <sup>3</sup>	7.9 m <sup>3</sup>	10.33 yd <sup>3</sup>
Weight, Dozer*	—		—		6880 kg	15,170 lb
General Dimensions (Tractor & Dozer)						
Length	—		—		10.42 m	34'2"
Width	4.34 m	14'3"	4.34 m	14'3"	5.07 m	16'7"
Blade:						
Width (including std. end bits)	4.34 m	14'3"	4.34 m	14'3"	5.07 m	16'7"
Height	1365 mm	4'6"	1365 mm	4'6"	1466 mm	4'9"
Max. Digging Depth	518 mm	20"	518 mm	20"	455 mm	17.9"
Ground Clearance @ Full Lift Under Skid Plate	956 mm	3'2"	956 mm	3'2"	1324 mm	4'7"
Tilt Adjust. from Horizontal	1139 mm	3'9"	1139 mm	3'9"	1270 mm	4'2"
Total Tip Adjustment	—		—		20.5°	

MODEL	834H		834H		844H		854K	
Type	U-Blade		SU-Blade		Semi-U		Semi-U	
Capacity**	11.13 m <sup>3</sup>	14.56 yd <sup>3</sup>	10.13 m <sup>3</sup>	13.25 yd <sup>3</sup>	15.9 m <sup>3</sup>	20.7 yd <sup>3</sup>	25.4 m <sup>3</sup>	33.1 yd <sup>3</sup>
Weight, Dozer*	8470 kg	18,670 lb	—		15 670 kg	34,520 lb	21 910 kg	48,270 lb
General Dimensions (Tractor & Dozer)								
Length	10.42 m	34'2"	—		10.94 m	35'9"	13.405 m	44'0"
Width	5.15 m	16'11"	4.69 m	15'5"	5.42 m	17'8"	6.321 m	20'7"
Blade:								
Width (including std. end bits)	5.15 m	16'11"	4.69 m	15'5"	5.42 m	17'8"	6.321 m	20'7"
Height	1437 mm	4'9"	1779 mm	5'10"	1834 mm	5'9"	2179 mm	7'1"
Max. Digging Depth	442 mm	17.4"	507 mm	20.0"	466 mm	18.3"	398 mm	15.7"
Ground Clearance @ Full Lift Under Skid Plate	1338 mm	4'4"	1352 mm	4'5"	1372 mm	4'6"	1540 mm	5'0.4"
Tilt Adjust. from Horizontal	1270 mm	4'2"	1270 mm	2'2"	830 mm	2'8.7"	1165 mm	3'8"
Total Tip Adjustment	22°		22°		13°		15°	

\*Total Bulldozer Arrangement.

\*\*Blade capacities determined by SAE J1265.

	814F2		824H		834H	
<b>Model:</b>	Coal U-Blade		Coal U-Blade		Coal U-Blade	
Replaces "S" Blade						
<b>Blade:</b>						
Capacity	11 m <sup>3</sup>	14 yd <sup>3</sup>	16.1 m <sup>3</sup>	21 yd <sup>3</sup>	22.3 m <sup>3</sup>	29 yd <sup>3</sup>
Length (Cutting Width)	4318 mm	14'2"	4801 mm	15'9"	5680 mm	18'7"
Height, wing section (tapered down)	1473 mm	4'10"	1803 mm	5'11"	1960 mm	6'5"
Wing Angle	25°		30°		30°	
Weight, Installed (Without Hydraulics)	1950 kg	4300 lb	3193 kg	7040 lb	5020 kg	11,300 lb

	844H		854K	
<b>Model:</b>	Coal U-Blade		Coal U-Blade	
Replaces "S" Blade				
<b>Blade:</b>				
Capacity	30.7 m <sup>3</sup>	40.2 yd <sup>3</sup>	44.7 m <sup>3</sup>	58.2 yd <sup>3</sup>
Length (Cutting Width)	5846 mm	19'2"	7200 mm	23'7"
Height, wing section (tapered down)	2024 mm	6'8"	2500 mm	8'2"
Wing Angle	30°		30°	
Weight, Installed (Without Hydraulics)	6237 kg	13,830 lb	10 333 kg	22,780 lb

	824H		834H	
<b>Model:</b>	Woodchip U-Blade		Woodchip U-Blade	
Replaces "S" Blade				
<b>Blade:</b>				
Capacity	24 m <sup>3</sup>	31 yd <sup>3</sup>	30.1 m <sup>3</sup>	40 yd <sup>3</sup>
Length (Cutting Width)	4775 mm	15'8"	5700 mm	18'8"
Height, wing section	2261 mm	7'5"	2350 mm	7'8"
Wing Angle	30°		30°	
Weight	3515 kg	7750 lb	5155 kg	11,600 lb

	814F2		824H		834H	
<b>Model:</b>	Coal Scoop with Tilt		Coal Scoop with Tilt		Coal Scoop with Tilt	
<b>Scoop:</b>						
Lift and Carrying Capacity	11.5 m <sup>3</sup>	15 yd <sup>3</sup>	13.4 m <sup>3</sup>	17.5 yd <sup>3</sup>	22.9 m <sup>3</sup>	30 yd <sup>3</sup>
Dozing Capacity	19.1 m <sup>3</sup>	25 yd <sup>3</sup>	26.8 m <sup>3</sup>	35 yd <sup>3</sup>	45.8 m <sup>3</sup>	60 yd <sup>3</sup>
Width	3734 mm	12'3"	4058 mm	13'4"	4880 mm	15'11"
Height	1626 mm	5'4"	1839 mm	6'1"	2382 mm	7'10"
Overall Length	7.3 m	24'0"	5.3 m	17'6"	—	—
Weight	5216 kg	11,500 lb	6763 kg	14,913 lb	9501 kg	20,949 lb
Dump Clearance	1041 mm	3'5"	1398 mm	4'7"	1524 mm	5'0"

	814F2		824H		834H	
<b>Model:</b>	Chip Scoop with Tilt		Chip Scoop with Tilt		Chip Scoop with Tilt	
<b>Scoop:</b>						
Lift and Carrying Capacity	15.3 m <sup>3</sup>	20 yd <sup>3</sup>	20.6 m <sup>3</sup>	27 yd <sup>3</sup>	26.7 m <sup>3</sup>	35 yd <sup>3</sup>
Dozing Capacity	30.6 m <sup>3</sup>	40 yd <sup>3</sup>	41.3 m <sup>3</sup>	54 yd <sup>3</sup>	53.5 m <sup>3</sup>	70 yd <sup>3</sup>
Width	3734 mm	12'3"	4039 mm	13'3"	4876 mm	16'0"
Height	2286 mm	7'6"	2489 mm	8'2"	2692 mm	8'10"
Weight	5390 kg	11,880 lb	11 420 kg	19,125 lb	9711 kg	21,410 lb



# SOIL COMPACTORS

## CONTENTS

Features	11-11
Specifications	11-12
Rimpull	11-13
Compaction Fundamentals	11-14
Compactor Types and Zones of Application	11-15
Estimating Production (Example Problem)	11-16
Production Table	11-17
Bulldozer Specifications	11-17
Ground Contact Pressures	11-18

## Features:

- **Dozing, filling and compacting versatility.**
- **High speed operation** with responsive Cat diesel engine, single-lever planetary power shift transmission, and all-wheel drive.
- **Articulated frame** makes maneuvering quick and easy. Long wheel base for stability.
- **Wheels with tamping foot design and chevron pattern** give traction, penetration and compaction needed for high production. Foot pattern reversed on trailing drums to prevent overprinting lead drums.
- **Rear drums track front** for double compactive effort. Drum spacing covers mid-axle strip on return pass.
- **Rear axle oscillation** keeps all drums on ground for traction and stability.
- **Cleaner bars** keep drums free of carry over earth regardless of rolling direction. Adjustable, replaceable.
- **Optional fill spreading dozer** has single lever control for raise, lower, hold and float. (Blade tilt optional.)





MODEL	815F2		825H	
Flywheel Power	173 kW	232 hp	264 kW	354 hp
Operating Weight*	20 755 kg	45,765 lb	32 734 kg	72,164 lb
Engine Model	C9 ACERT		C15 ACERT	
Rated Engine RPM	2100		1800	
No. Cylinders	6		6	
Displacement	8.8 L	537 in <sup>3</sup>	15.1 L	928 in <sup>3</sup>
Speeds:				
Forward	3		3	
Reverse	3		3	
Turning Radius — outside Corner of Blade	6.45 m	21'3"	7.4 m	24'0"
Fuel Tank Refill Capacity	446 L	118 U.S. gal	603 L	159 U.S. gal
TAMPING FOOT WHEELS:				
Each Drum Width	991 mm	3'3"	1125 mm	3'8"
Diameters, over feet	1.42 m	4'8"	1.68 m	5'5"
over drum	1.03 m	3'5"	1.29 m	4'3"
Feet per Wheel	60		65	
Feet per Row	12		13	
Rows of Feet	5		5	
Foot Length	191 mm	7.5"	188 mm	7.4"
End Area Per Foot	134 cm <sup>2</sup>	20.8 in <sup>2</sup>	192 cm <sup>2</sup>	29.75 in <sup>2</sup>
Width of Two Pass Coverage	4.2 m	13'9"	5.3 m	17'4"
GENERAL DIMENSIONS:				
Height (top of ROPS)	3.34 m	11'0"	3.75 m	12'3"
Height (stripped top)**	2.39 m	7'10"	2.69 m	8'10"
Wheel Base	3.35 m	11'0"	3.7 m	12'1"
Overall Length with Dozer	6.80 m	23'6"	8.43 m	27'8"
Width over Drums	3.24 m	10'8"	3.65 m	12'0"
Ground Clearance	390 mm	15.4"	414 mm	16"
STRAIGHT BULLDOZER:				
Width over End Bits	3.76 m	12'4"	4.62 m	15'1"
Height with Cutting Edge	860 mm	2'10"	1030 mm	3'4"

\*Operating Weight includes coolant, lubricants, bulldozer, hydraulics, ROPS canopy, full fuel tank and operator.

\*\*Height (stripped top) — without ROPS, exhaust, seat back or other easily removed encumbrances.

815F2

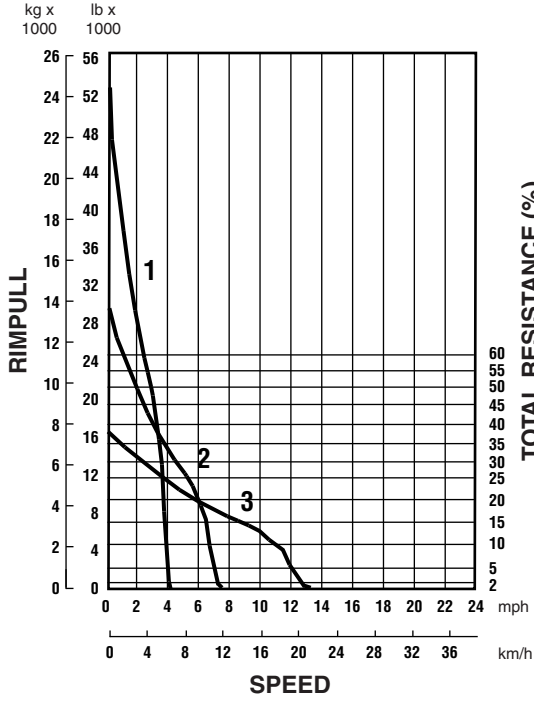

825H

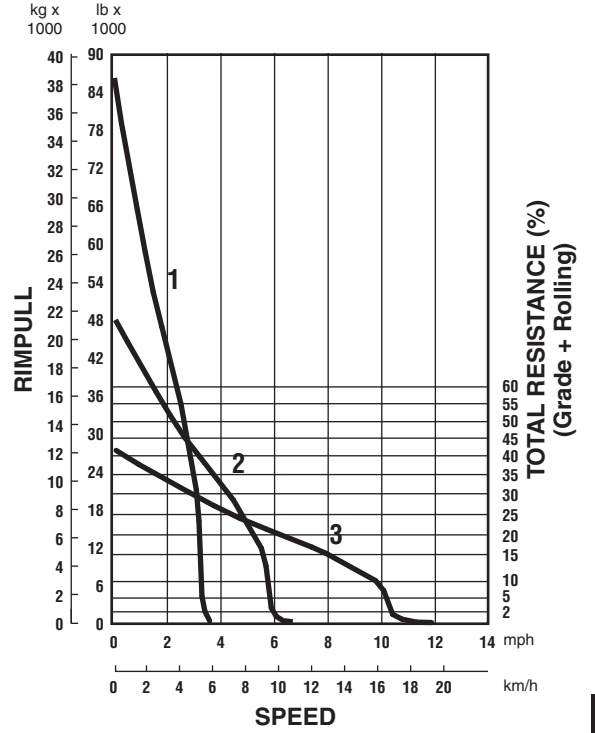

KEY  
 1 - 1st Gear  
 2 - 2nd Gear  
 3 - 3rd Gear

**COMPACTION FUNDAMENTALS**

The following discussion applies to soil compaction only. For information on refuse compaction, see Waste Disposal section of this book.

**Definition**

Compaction is the process of physically densifying or packing the soil ... resulting in increased weight per unit volume. It is generally accepted that the strength of a soil can be increased by densification. Three important factors affect compaction.

- Material gradation
- Moisture content
- Compactive effort

*Material Gradation* — refers to the distribution (% by weight) of the different particle sizes within a given soil sample. A sample is *well-graded* if it contains a good, even distribution of particle sizes. A sample composed of predominantly one size particle, is said to be *poorly-graded*. In terms of compaction, a well-graded soil will compact more easily than one that is poorly-graded. In well-graded material the smaller particles tend to fill the empty spaces between the larger particles, leaving fewer voids after compaction.

**MATERIAL GRADATION**

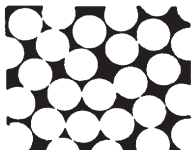

Poorly-graded

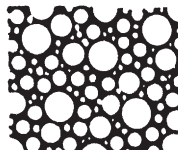

Well-graded

*Moisture Content* — or the amount of water present in a soil, is very important to compaction. Water lubricates soil particles thus helping them slide into the most dense position. Water also creates clay particle bonding, giving cohesive materials their sticky qualities.

**OPTIMUM MOISTURE**

Heavy clay	17.5%
Silty clay	15.0%
Sandy clay	13.0%
Sand	10.0%
Gravel, sand, clay mix (pit run)	7.0%

Experience has shown that it is very difficult, if not impossible, to achieve proper compaction in materials that are too dry or too wet. Soil experts have determined that in practically every soil there is an amount of water, called optimum moisture content, at which it is possible to obtain maximum density with a given amount of compactive effort. The curve below shows this relationship between dry density and moisture content. It is called a compaction curve, moisture-density curve or Proctor curve.

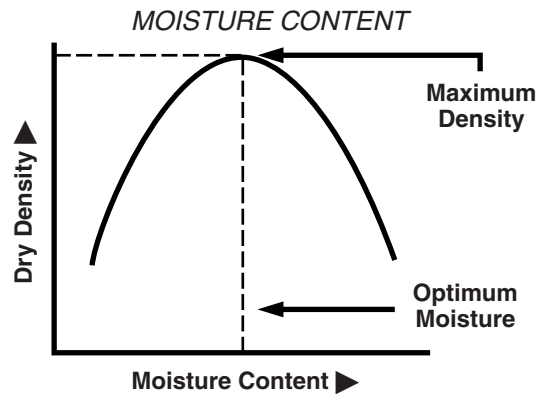

*Compactive Effort* — refers to the method employed by a compactor to impart energy into the soil to achieve compaction. Compactors are designed to use one or a combination of the following types of compactive effort.

- Static weight (or pressure)
- Kneading action (or manipulation)
- Impact (or sharp blow)
- Vibration (or shaking)

## COMPACTOR TYPES

Compaction equipment can be grouped generally into the following classifications:

- sheepsfoot
- vibratory
- pneumatic
- high speed tamping foot
- chopper wheels (see Landfill Compactor section)

Combinations of these types are also available, such as a vibrating smooth steel drum.

For ease of comparison, the compactors have been placed on the Zones of Application Chart shown below. This chart contains a range of material moistures from 100% clay to 100% sand, plus a rock zone. Each type has been positioned in what is considered to be its most effective and economical zone of application. However, it is not uncommon to find them working out of their zones. Exact positioning of the zones can vary with differing material conditions.

### RANGES OF SOIL TYPES FOR SOIL COMPACTION EQUIPMENT

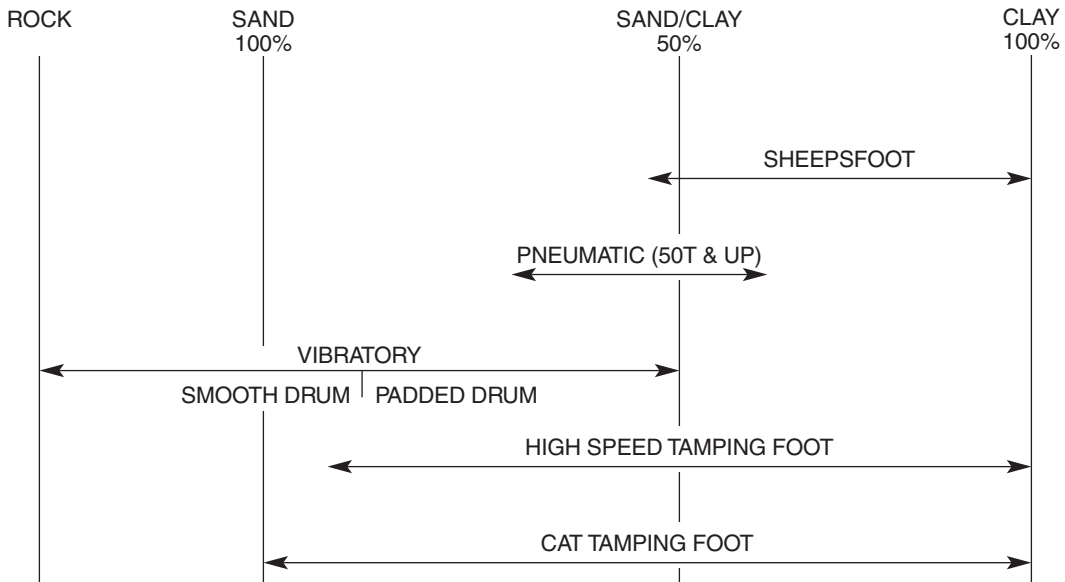

**COMPACTOR PRODUCTION**

Compactor production is expressed in compacted cubic meters (Cm<sup>3</sup>) or compacted cubic yards (CCY) per hour. Material in its natural or bank state is measured in bank cubic meters or yards (Bm<sup>3</sup> or BCY). When it is removed or placed in a fill, it is measured in loose cubic meters or yards (Lm<sup>3</sup> or LCY).

When the loose material is worked into a compacted state, the relationship of *compacted material to bank material* is shown as the shrinkage factor (SF).

$$SF = \frac{\text{Compacted cubic meters (Cm}^3\text{)}}{\text{Bank cubic meters (Bm}^3\text{)}}$$

$$SF = \frac{\text{Compacted cubic yards (CCY)}}{\text{Bank cubic yards (BCY)}}$$

The construction industry has developed the following formula for use in estimating compactor production. This formula gives the material volume a given machine can compact in a 60-minute hour.

**Metric Method**

$$\text{Cm}^3 = \frac{W \times S \times L}{P}$$

W = Compacted width per pass, in meters. (For Cat Compactors it is recommended that W = Twice the width of one wheel.)

S = Average speed, in kilometers per hour.

L = Compacted thickness of lift, in millimeters.

P = Number of machine passes to achieve compaction (**can only be determined by testing the compacted material density on-the-job**).

**English Method**

$$\text{CCY/hr} = \frac{W \times S \times L \times 16.3}{P}$$

W = Compacted width per pass, in feet. (For Cat Compactors it is recommended that W = Twice the width of one wheel.)

S = Average speed, in miles per hour.

L = Compacted thickness of lift, in inches.

16.3 = Conversion constant, equals 5280 feet ÷ 12 inches ÷ 27 cubic feet

P = Number of machine passes to achieve compaction (**can only be determined by testing the compacted material density on-the-job**).

Example problem (Metric)

Determine production for an 815F2 operating under the following conditions:

$$P = 5, S = 10 \text{ km/h}, L = 100 \text{ mm}$$

Refer to 815F2 in the production table on the next page. Read down the first column until reaching section for 5 passes. Within this section in the second column, find the speed closest to 10 km/h. Read across this line to the 100 mm compacted lift. Read the production figure given.

**Answer:** 377 Cm<sup>3</sup>/h. (Since the machine's speed of 10 km/h is slightly faster than the 9.5 of the table, production may be interpolated slightly higher — say 395 Cm<sup>3</sup>/h.)

Example problem (English)

Determine production for an 825H operating under the following conditions:

$$P = 4, S = 8 \text{ mph}, L = 6 \text{ inches}$$

Refer to the production estimating table on the next page. This table contains estimates for the 815F2 and 825H Compactors using various speeds, lift thicknesses and number of passes. These figures were calculated using the formula discussed on this page. The figures represent 100% efficiency. W = Twice the width of one wheel.

In the 825H portion of this table, read down the first column until reaching the section for four passes. Within this section in the second column, find the line for 8 mph. Read across this line to the lift thickness column for 6 inches. Read the production figure given.

**Answer:** 1444 CCY/hr.



**PRODUCTION TABLE**

MODEL AND MACHINE PASSES*	AVERAGE SPEED km/h    mph		COMPACTED LIFT THICKNESS								
			100 mm m³/h	4 in yd³/hr	150 mm m³/h	6 in yd³/hr	200 mm m³/h	8 in yd³/hr	250 mm m³/h	10 in yd³/hr	
<b>815F2</b>	3	6.5	4	419	548	628	822	837	1095	—	—
		9.5	6	628	822	942	1232	1256	1643	—	—
		13.0	8	837	1095	1256	1643	1675	2191	—	—
	4	6.5	4	314	411	471	616	628	822	—	—
		9.5	6	471	616	706	924	942	1232	—	—
		13.0	8	628	822	942	1232	1256	1643	—	—
	5	6.5	4	251	329	377	493	502	657	—	—
		9.5	6	377	493	565	739	754	986	—	—
		13.0	8	502	657	754	986	1005	1314	—	—
	6	6.5	4	286	274	314	411	419	548	—	—
		9.5	6	314	411	471	616	628	822	—	—
		13.0	8	419	548	628	822	837	1095	—	—
<b>825H</b>	3	6.5	4	488	642	731	962	975	1283	1219	1604
		9.5	6	713	962	1069	1444	1425	1925	1781	2406
		13.0	8	975	1283	1463	1925	1950	2566	2438	3208
	4	6.5	4	366	481	534	722	731	962	914	1203
		9.5	6	534	722	802	1083	1069	1444	1336	1804
		13.0	8	731	962	1097	1444	1463	1925	1828	2406
	5	6.5	4	293	385	439	577	585	770	731	962
		9.5	6	428	577	641	866	855	1155	1069	1444
		13.0	8	585	770	878	1155	1170	1540	1463	1925
	6	6.5	4	244	321	366	481	488	642	609	802
		9.5	6	356	481	534	722	713	962	891	1203
		13.0	8	488	642	731	962	975	1283	1219	1604

\*The number of machine passes required is dependent on soil type, moisture content, desired compaction and machine weight.

MODEL	815F2		825H	
Type	Fill Spreading		Fill Spreading	
Capacity**				
Earth	2.16 m³	2.82 yd³	3.79 m³	4.95 yd³
Refuse	—	—	—	—
Weight, Dozer*	1460 kg	3220 lb	2831 kg	6241 lb
General Dimensions: (Tractor & Dozer)				
Length	6.82 m	22'5"	8.24 m	27'5"
Width	3.76 m	12'4"	4.6 m	15'1"
Blade Dimensions:				
Width, End Bits	3.76 m	12'4"	4.6 m	15'1"
Height, Moldboard	860 mm	2'10"	1.03 m	3'4"
Height, Trash Rack	—	—	—	—
Max. Digging Depth	215 mm	8.5"	312 mm	12.3"
Ground Clearance @ Full Lift	814 mm	2'8"	932 mm	3'0.7"
Tilt Adjust. from Horizontal	328 mm	12.9"	797 mm	31.4"

\*Total Bulldozer Arrangement.

\*\*Blade capacities determined by SAE recommended practice J1265.

**815F2 and 825H  
Ground Contact Pressure/Soil Compactors**

<b>815F2 Tip</b>	<b>Weight Front Axle 9376 kg (20,674 lb) Ground Contact Pressure</b>		<b>Weight Rear Axle 11 460 kg (25,269 lb) Ground Contact Pressure</b>		<b>Contact Area Four Wheels</b>	
	<b>kPa</b>	<b>psi</b>	<b>kPa</b>	<b>psi</b>	<b>cm<sup>2</sup></b>	<b>in<sup>2</sup></b>
Tip Penetration						
12.5 mm (0.5 in)	4727.05	<b>685.6</b>	6989.35	<b>706.7</b>	425.81	<b>66</b>
25 mm (1.0 in)	1347.92	<b>195.5</b>	1827.94	<b>215.7</b>	1445.16	<b>224</b>
38 mm (1.5 in)	902.52	<b>130.9</b>	1094.20	<b>156.8</b>	2077.42	<b>322</b>
50 mm (2.0 in)	658.45	<b>95.5</b>	872.95	<b>97.7</b>	3064.51	<b>475</b>

<b>825H Standard Tip</b>	<b>Weight Front Axle 14 919.98 kg (32,892.93 lb) Ground Contact Pressure</b>		<b>Weight Rear Axle 16 819.98 kg (37,081.71 lb) Ground Contact Pressure</b>		<b>Contact Area Four Wheels</b>	
	<b>kPa</b>	<b>psi</b>	<b>kPa</b>	<b>psi</b>	<b>cm<sup>2</sup></b>	<b>in<sup>2</sup></b>
Tip Penetration						
12.7 mm (0.5 in)	7178.41	<b>1041.14</b>	8092.55	<b>1173.73</b>	407.65	<b>63.19</b>
25 mm (1.0 in)	2609.39	<b>378.46</b>	2941.72	<b>426.66</b>	1121.55	<b>173.84</b>
38 mm (1.5 in)	1411.35	<b>204.70</b>	1591.10	<b>230.77</b>	2073.54	<b>321.40</b>
50 mm (2.0 in)	704.99	<b>102.25</b>	794.76	<b>115.27</b>	4150.96	<b>643.40</b>
75 mm (3.0 in)	610.19	<b>88.50</b>	687.89	<b>99.77</b>	4795.60	<b>743.32</b>
100 mm (4.0 in)	421.68	<b>61.16</b>	475.39	<b>68.95</b>	6939.86	<b>1075.68</b>
125 mm (5.0 in)	382.52	<b>55.48</b>	431.27	<b>62.55</b>	7650.04	<b>1185.76</b>
150 mm (6.0 in)	324.33	<b>47.04</b>	365.63	<b>53.03</b>	9022.18	<b>1398.44</b>
175 mm (7.0 in)	311.09	<b>45.12</b>	350.74	<b>50.87</b>	9405.66	<b>1457.88</b>
200 mm (8.0 in)	139.55	<b>20.24</b>	157.34	<b>22.82</b>	20 965.89	<b>3249.72</b>

<b>825H Heavy Duty Tip</b>	<b>Weight Front Axle 14 919.98 kg (32,892.93 lb) Ground Contact Pressure</b>		<b>Weight Rear Axle 16 819.98 kg (37,081.71 lb) Ground Contact Pressure</b>		<b>Contact Area Four Wheels</b>	
	<b>kPa</b>	<b>psi</b>	<b>kPa</b>	<b>psi</b>	<b>cm<sup>2</sup></b>	<b>in<sup>2</sup></b>
Tip Penetration						
12.7 mm (0.5 in)	7615.41	<b>1104.52</b>	8585.20	<b>1245.18</b>	96.07	<b>14.89</b>
25 mm (1.0 in)	6199.83	<b>899.21</b>	6989.35	<b>1013.72</b>	472.00	<b>73.16</b>
38 mm (1.5 in)	3614.20	<b>524.19</b>	1915.27	<b>277.79</b>	430.61	<b>66.74</b>
50 mm (2.0 in)	1621.44	<b>235.17</b>	1827.94	<b>265.12</b>	1804.64	<b>279.72</b>
75 mm (3.0 in)	970.64	<b>140.78</b>	1094.20	<b>158.70</b>	3014.96	<b>467.32</b>
100 mm (4.0 in)	774.28	<b>112.30</b>	872.95	<b>126.61</b>	3779.35	<b>585.80</b>
125 mm (5.0 in)	570.89	<b>82.80</b>	643.56	<b>93.34</b>	5126.18	<b>794.56</b>
150 mm (6.0 in)	443.13	<b>64.27</b>	499.59	<b>72.46</b>	6603.60	<b>1023.56</b>
175 mm (7.0 in)	417.06	<b>60.49</b>	470.22	<b>68.20</b>	7016.24	<b>1087.52</b>
200 mm (8.0 in)	389.07	<b>56.43</b>	438.64	<b>63.62</b>	7520.76	<b>1165.72</b>
225 mm (9.0 in)	381.07	<b>55.27</b>	429.61	<b>62.31</b>	7678.95	<b>1190.24</b>
250 mm (10.0 in)	128.59	<b>18.65</b>	145.00	<b>21.03</b>	22 753.76	<b>3526.84</b>

# WHEEL LOADERS INTEGRATED TOOLCARRIERS

## CONTENTS

Wheel Loaders:	
Features	12-1
Integrated Toolcarriers:	
Features	12-2
Specifications	12-3
Performance Data	12-9
Machine Dimensions	12-83
SAE Loader Ratings	12-110
Machine Selection:	
Cycle Time Factors	12-112
Truck Loading	12-113
Bucket Fill Factors	12-113
Example Problem	12-114
Alternative Method of Selection	12-115
Nomographs	12-116
Machine/Attachment Selection	12-118
Bucket Selection	12-124
Estimated Haul or Return Time Charts	12-138
Travel Time Charts	12-139
988H Rimpull-Speed-Gradeability Charts	12-151
Travel Time Charts	12-153
990H Rimpull-Speed-Gradeability Charts	12-157
Travel Time Charts	12-158
992K Rimpull-Speed-Gradeability Charts	12-160
Travel Time Charts	12-162
993K Rimpull-Speed-Gradeability Charts	12-164
Travel Time Charts	12-166
994F Rimpull-Speed-Gradeability Charts	12-170
Travel Time Charts	12-171
Production Estimating Tables:	
Cubic Meters and Cubic Yards	12-175
Metric Tons and U.S. Tons in Shot Rock	12-176
Work Tools:	
Wheel Loaders	12-178
Integrated Toolcarriers	12-179
Fusion Coupler System	12-180
Work Tools	12-181
Waste Handling Wheel Loaders	25-31

## WHEEL LOADERS

### Features:

- Cat heavy duty diesel engine.
- Productive operator environment. Excellent visibility.
- Automatic lift and bucket controls.
- Adjustable suspension seat and steering column.
- Four wheel enclosed wet disc brakes.
- Automatic power shift transmissions. Allows operator to select automatic or manual mode.
- Hydrostatic drive on 906H, 908H and 914G.
- Transmission neutralizer switch (924H, 924Hz, 928Hz, 930H, 938H-980H).
- Computerized machine function monitoring.
- Command control steering with integrated transmission controls and electro-hydraulic controls ... 950H-980H.
- Lock up clutch on 990H and 994F (optional on 988H).
- Impeller clutch on 988H, 990H, 992K, 993K and 994F.
- Tilting hood ... 938H-980H.
- Brake wear indicator.
- Limited slip differentials.
- Differential locks ... 938H.
- Automatic Ride Control suspension system. Operator select "on", "off" or "automatic".
- Payload control system.
- Optional Fusion™ coupler system for work tool interchangeability with pin-on performance. Work tools can interchange across the entire SWL/MWL/IT line.

Listed features may be standard on some models, optional or unavailable on others. Contact your Cat dealer for specific information.



## **INTEGRATED TOOLCARRIERS**

### **Features:**

- **Integral quick coupler** for fast tool changes.
- **Wide range of tools** available to meet many jobs.
- **Increased lift height and reach** over conventional loaders.
- **Parallel lift** from ground level to maximum height.
- **High tilt force** throughout lift cycle provides exceptional load control.
- **Transmission neutralizer lockout switch** for low speed maneuverability is standard. (IT14G-IT62H)
- **Positive carry position** for load stability and retention.
- **Third and fourth valves available** for multiple tool functions.
- **Work tool interchangeability.** Optional Fusion coupler system for work tool interchangeability with pin-on performance. Work tools can interchange across the entire SWL/MWL/IT line.
- **Excellent center visibility** to quick coupler and work tool.
- **Two position return** to work kickouts.
- **Several quick-coupler work tools** for IT38H and IT62H are available from the factory and ship with the machine. Contact your Cat dealer for details.



MODEL	904H		906H		907H		908H	
Flywheel Power: Net	39 kW	52 hp	51 kW	68.4 hp	51 kW	68.4 hp	58 kW	77.8 hp
Gross	41 kW	55 hp	55 kW	73.8 hp	55 kW	73.8 hp	62 kW	83 hp
Engine Model	MHI S4Q2-T		C3.4		C3.4		C3.4	
Rated Engine RPM	2400		2500		2500		2500	
Bore	88 mm	3.46"	94 mm	3.7"	94 mm	3.7"	94 mm	3.7"
Stroke	103 mm	4.06"	120 mm	4.72"	120 mm	4.72"	120 mm	4.72"
No. Cylinders	4		4		4		4	
Displacement	2.505 L	153 in <sup>3</sup>	3.331 L	203.3 in <sup>3</sup>	3.331 L	203.3 in <sup>3</sup>	3.331 L	203.3 in <sup>3</sup>
Speeds Forward	km/h mph		km/h mph		km/h mph		km/h mph	
1st	7 Lo	4	7 Lo	4	7 Lo	4	7 Lo	4
2nd	20 Hi	12	20 Hi	12	20 Hi	12	20 Hi	12
Speeds Reverse	km/h mph		km/h mph		km/h mph		km/h mph	
1st	7 Lo	4	7 Lo	4	7 Lo	4	7 Lo	4
2nd	20 Hi	12	20 Hi	12	20 Hi	12	20 Hi	12
Hydraulic Cycle Time, Rated Load in Bucket:	Seconds		Seconds		Seconds		Seconds	
Raise	4.5		5		5		5	
Dump	0.8		2		2		2	
Lower (Empty, Float Down)	3.2		4		4		4	
Total	8.5		11		11		11	
Tread Width	1327 mm	4'4"	1420 mm	4'8"	1420 mm	4'8"	1590 mm	5'2"
Width Over Tires	1642 mm	5'5"	1820 mm	5'11"	1820 mm	5'11"	1993 mm	78.6"
Ground Clearance	287 mm	11"	301 mm	12"	301 mm	12"	340 mm	14"
Fuel Tank Capacity	83 L	22 U.S. gal	52 L	13.7 U.S. gal	78 L	20.6 U.S. gal	78 L	20.6 U.S. gal
Hydraulic Tank Capacity	30 L	7.9 U.S. gal	84 L	22.2 U.S. gal	84 L	22.2 U.S. gal	84 L	22.2 U.S. gal
Hydraulic System Capacity (includes tank)	43 L	11 U.S. gal	95 L	25.1 U.S. gal	95 L	25.1 U.S. gal	95 L	25.1 U.S. gal

# Wheel Loaders Integrated Toolcarriers

## Specifications



MODEL	914G/IT14G		924Hz		924H Standard VersaLink Pin On/Hook On		924H High Lift VersaLink Pin On/Hook On	
	Flywheel Power: Net Gross	72 kW 75 kW	96 hp 101 hp	97 kW 98 kW	130 hp 132 hp	97 kW 98 kW	130 hp 132 hp	97 kW 98 kW
Engine Model	Cat 3054C DIT		C6.6		C6.6		C6.6	
Rated Engine RPM	2200		2300		2300		2300	
Bore	100 mm	3.94"	105 mm	4.13"	105 mm	4.13"	105 mm	4.13"
Stroke	127 mm	5"	127 mm	5"	127 mm	5"	127 mm	5"
No. Cylinders	4		6		6		6	
Displacement	4 L	243 in <sup>3</sup>	6.6 L	403 in <sup>3</sup>	6.6 L	403 in <sup>3</sup>	6.6 L	403 in <sup>3</sup>
Speeds Forward	km/h mph		km/h mph		km/h mph		km/h mph	
1st	9 Lo	5.6	6.9	4.3	6.9	4.3	6.9	4.3
2nd	35 Hi	22	12.9	8.0	12.9	8.0	12.9	8.0
3rd	—	—	22.9	14.2	22.9	14.2	22.9	14.2
4th	—	—	39.7	24.7	39.7	24.7	39.7	24.7
Speeds Reverse	km/h mph		km/h mph		km/h mph		km/h mph	
1st	9 Lo	5.6	6.9	4.3	6.9	4.3	6.9	4.3
2nd	35 Hi	22	12.9	8.0	12.9	8.0	12.9	8.0
3rd	—	—	22.9	14.2	22.9	14.2	22.9	14.2
Hydraulic Cycle Time, Rated Load in Bucket:	Seconds		Seconds		Seconds		Seconds	
Raise	914G 5.6	IT14G 6.9	5.2		5.2		5.2	
Dump	2.1	2.5	1.2		1.6		1.9	
Lower (Empty, Float Down)	3.2	3.1	3.0		2.7		2.4	
Total	10.9	12.5	9.4		9.5		9.5	
Tread Width	1.80 m	5'11"	1.88 m	6'2"	1.88 m	6'2"	1.88 m	6'2"
Width Over Tires	2.26 m	7'5"	2.49 m	8'2"	2.49 m	8'2"	2.49 m	8'2"
Ground Clearance	456 mm	18"	436 mm	17"	436 mm	17"	436 mm	17"
Fuel Tank Capacity	150 L	39.6 U.S. gal	225 L	59.4 U.S. gal	225 L	59.4 U.S. gal	225 L	59.4 U.S. gal
Hydraulic Tank Capacity	70 L	18.5 U.S. gal	70 L	18.5 U.S. gal	70 L	18.5 U.S. gal	70 L	18.5 U.S. gal
Hydraulic System Capacity (includes tank)	100 L	26.4 U.S. gal	148 L	39 U.S. gal	148 L	39 U.S. gal	148 L	39 U.S. gal



**930H  
Standard  
VersaLink**

**930H  
High Lift  
VersaLink**

<b>MODEL</b>	<b>928Hz</b>		<b>Pin On/Hook On</b>		<b>Pin On/Hook On</b>		<b>938H/IT38H</b>	
Flywheel Power: Net	112 kW	<b>150 hp</b>	112 kW	<b>150 hp</b>	112 kW	<b>150 hp</b>	134 kW	<b>180 hp</b>
Gross	113 kW	<b>152 hp</b>	113 kW	<b>152 hp</b>	113 kW	<b>152 hp</b>	147 kW	<b>197 hp</b>
Engine Model	<b>C6.6</b>		<b>C6.6</b>		<b>C6.6</b>		<b>C6.6</b>	
Rated Engine RPM	<b>2300</b>		<b>2300</b>		<b>2300</b>		<b>2100</b>	
Bore	105 mm	<b>4.13"</b>	105 mm	<b>4.13"</b>	105 mm	<b>4.13"</b>	105 mm	<b>4.13"</b>
Stroke	127 mm	<b>5"</b>	127 mm	<b>5"</b>	127 mm	<b>5"</b>	127 mm	<b>5"</b>
No. Cylinders	<b>6</b>		<b>6</b>		<b>6</b>		<b>6</b>	
Displacement	6.6 L	<b>403 in<sup>3</sup></b>	6.6 L	<b>403 in<sup>3</sup></b>	6.6 L	<b>403 in<sup>3</sup></b>	6.6 L	<b>403 in<sup>3</sup></b>
Speeds Forward	<b>km/h</b>	<b>mph</b>	<b>km/h</b>	<b>mph</b>	<b>km/h</b>	<b>mph</b>	<b>km/h</b>	<b>mph</b>
1st	8.1	<b>5.0</b>	6.9	<b>4.3</b>	6.9	<b>4.3</b>	7.9	<b>4.9</b>
2nd	12.9	<b>8.0</b>	12.9	<b>8.0</b>	12.9	<b>8.0</b>	14.2	<b>8.8</b>
3rd	26.7	<b>16.6</b>	22.9	<b>14.2</b>	22.9	<b>14.2</b>	25.0	<b>15.5</b>
4th	37.6	<b>23.4</b>	39.7	<b>24.7</b>	39.7	<b>24.7</b>	41.1	<b>25.5</b>
Speeds Reverse								
1st	8.1	<b>5.0</b>	6.9	<b>4.3</b>	6.9	<b>4.3</b>	7.9	<b>4.9</b>
2nd	12.8	<b>8.0</b>	12.9	<b>8.0</b>	12.9	<b>8.0</b>	14.2	<b>8.8</b>
3rd	26.7	<b>16.6</b>	22.9	<b>14.2</b>	22.9	<b>14.2</b>	25.0	<b>15.5</b>
Hydraulic Cycle Time, Rated Load in Bucket:	<b>Seconds</b>		<b>Seconds</b>		<b>Seconds</b>		<b>Seconds</b>	
Raise	<b>6.0</b>		<b>5.0</b>		<b>5.4</b>		<b>938H</b>	<b>IT38H</b>
Dump	<b>1.2</b>		<b>1.7</b>		<b>2.2</b>		<b>5.4</b>	<b>5.0</b>
Lower (Empty, Float Down)	<b>3.0</b>		<b>2.9</b>		<b>2.7</b>		<b>2.7</b>	<b>2.7</b>
Total	<b>10.2</b>		<b>9.6</b>		<b>10.3</b>		<b>9.5</b>	<b>9.7</b>
Tread Width	1.95 m	<b>6'5"</b>	1.96 m	<b>6'5"</b>	1.96 m	<b>6'5"</b>	2.02 m	<b>6'8"</b>
Width Over Tires	2.57 m	<b>8'5"</b>	2.57 m	<b>8'5"</b>	2.57 m	<b>8'5"</b>	2.65 m	<b>8'8"</b>
Ground Clearance	408 mm	<b>16"</b>	411 mm	<b>16"</b>	411 mm	<b>16"</b>	397 mm	<b>16"</b>
Fuel Tank Capacity	225 L	<b>59.4 U.S. gal</b>	225 L	<b>59.4 U.S. gal</b>	225 L	<b>59.4 U.S. gal</b>	247 L	<b>65.3 U.S. gal</b>
Hydraulic Tank Capacity	70 L	<b>18.5 U.S. gal</b>	70 L	<b>18.5 U.S. gal</b>	70 L	<b>18.5 U.S. gal</b>	89 L	<b>23.5 U.S. gal</b>
Hydraulic System Capacity (includes tank)	120 L	<b>32 U.S. gal</b>	148 L	<b>39 U.S. gal</b>	148 L	<b>39 U.S. gal</b>	162 L	<b>42.8 U.S. gal</b>

# Wheel Loaders Integrated Toolcarriers

## Specifications



MODEL	950H		962H/IT62H		966H	
Flywheel Power: Net	146 kW	196 hp	158 kW	211 hp	195 kW	262 hp
Gross	161 kW	216 hp	172 kW	230 hp	211 kW	283 hp
Engine Model	C7 ATAAC		C7 ATAAC		C11 ATAAC	
Rated Engine RPM	1800		1800		1800	
Bore	110 mm	4.3"	110 mm	4.3"	130 mm	5.1"
Stroke	127 mm	5"	127 mm	5"	140 mm	5.5"
No. Cylinders	6		6		6	
Displacement	7.2 L	439 in <sup>3</sup>	7.2 L	439 in <sup>3</sup>	11.1 L	677 in <sup>3</sup>
Speeds Forward	km/h	mph	km/h	mph	km/h	mph
1st	6.9	4.3	7.0	4.4	6.7	4.2
2nd	12.7	7.9	13.0	8.1	12.6	7.8
3rd	22.3	13.9	22.6	14.0	22.1	13.7
4th	37.0	23.0	38.0	23.6	37.4	23.2
Speeds Reverse						
1st	7.6	4.7	7.6	4.7	7.4	4.6
2nd	13.9	8.6	13.9	8.6	13.9	8.6
3rd	24.5	15.2	24.5	15.2	24.3	15.1
4th	40.0	24.9	40.0	24.9	37.4	23.2
Hydraulic Cycle Time, Rated Load in Bucket:	Seconds		Seconds		Seconds	
Raise	6.2		962H 6.2	IT62H 6.0	5.9	
Dump	1.3		1.3	2.1	1.6	
Lower (Empty, Float Down)	2.5		2.5	2.6	2.4	
Total	10.0		10.0	10.7	9.9	
Tread Width	2.14 m	7'0"	2.14 m	7'0"	2.23 m	7'4"
Width Over Tires	2.79 m	9'2"	2.79 m	9'2"	3.06 m	9'10"
Ground Clearance	412 mm	16"	412 mm	16"	496 mm	20"
Fuel Tank Capacity	314 L	83 U.S. gal	314 L	83 U.S. gal	380 L	100 U.S. gal
Hydraulic Tank Capacity	110 L	29 U.S. gal	110 L	29 U.S. gal	110 L	29 U.S. gal
Hydraulic System Capacity (includes tank)	186 L	48.4 U.S. gal	186 L	48.4 U.S. gal	200 L	52 U.S. gal



MODEL	972H		980H		988H		990H	
Flywheel Power: Net	214 kW	<b>287 hp</b>	260 kW	<b>349 hp</b>	373 kW	<b>501 hp</b>	468 kW	<b>627 hp</b>
Gross	229 kW	<b>307 hp</b>	293 kW	<b>392 hp</b>	414 kW	<b>555 hp</b>	512 kW	<b>687 hp</b>
Rated Payload*	—		—		11.4 t	<b>12.5 T</b>	15 t	<b>16.5 T</b>
Gross Rated Bucket Payload*	—		—		16 300 kg	<b>36,000 lb</b>	22 700 kg	<b>50,000 lb</b>
Engine Model	<b>C13 ATAAC</b>		<b>C15 ATAAC</b>		<b>C18 ACERT</b>		<b>C27 ACERT</b>	
Rated Engine RPM	<b>1800</b>		<b>1800</b>		<b>1800</b>		<b>2000</b>	
Bore	130 mm	<b>5.1"</b>	137 mm	<b>5.4"</b>	145 mm	<b>5.7"</b>	137 mm	<b>5.4"</b>
Stroke	157 mm	<b>6.2"</b>	171 mm	<b>6.75"</b>	183 mm	<b>7.2"</b>	152 mm	<b>6"</b>
No. Cylinders	<b>6</b>		<b>6</b>		<b>6</b>		<b>12</b>	
Displacement	12.5 L	<b>763 in<sup>3</sup></b>	15.2 L	<b>928 in<sup>3</sup></b>	18.1 L	<b>1104.5 in<sup>3</sup></b>	27.1 L	<b>1666 in<sup>3</sup></b>
Speeds Forward	<b>km/h</b>	<b>mph</b>	<b>km/h</b>	<b>mph</b>	<b>km/h</b>	<b>mph</b>	<b>km/h</b>	<b>mph</b>
1st	7.2	<b>4.5</b>	6.6	<b>4.1</b>	6.7	<b>4.2</b>	7.0	<b>4.3</b>
2nd	12.6	<b>7.8</b>	11.8	<b>7.3</b>	11.8	<b>7.3</b>	12.1	<b>7.5</b>
3rd	21.4	<b>13.3</b>	20.7	<b>12.9</b>	20.8	<b>12.9</b>	20.8	<b>13.0</b>
4th	36.9	<b>22.9</b>	36.3	<b>22.6</b>	36.0	<b>22.3</b>	—	
Speeds Reverse								
1st	8.2	<b>5.1</b>	7.6	<b>4.7</b>	7.6	<b>4.7</b>	7.7	<b>4.8</b>
2nd	14.2	<b>8.8</b>	13.5	<b>8.4</b>	13.5	<b>8.4</b>	13.4	<b>8.3</b>
3rd	24.3	<b>15.1</b>	23.6	<b>14.7</b>	23.7	<b>14.7</b>	22.9	<b>14.2</b>
4th	38.8	<b>24.0</b>	41.5	<b>25.8</b>	—		—	
Hydraulic Cycle Time, Rated Load in Bucket:	<b>Seconds</b>		<b>Seconds</b>		<b>Seconds</b>		<b>Seconds</b>	
Raise	<b>5.9</b>		<b>6.0</b>		<b>9.4</b>		<b>9.2</b>	
Dump	<b>2.1</b>		<b>2.1</b>		<b>2.4</b>		<b>2.9</b>	
Lower (Empty, Float Down)	<b>2.4</b>		<b>3.4</b>		<b>3.8</b>		<b>3.8</b>	
Total	<b>10.4</b>		<b>11.5</b>		<b>15.6</b>		<b>15.9</b>	
Tread Width	2.23 m	<b>7'4"</b>	2.44 m	<b>8'0"</b>	2.59 m	<b>8'6"</b>	3.1 m	<b>10'2"</b>
Width Over Tires	3.00 m	<b>9'10"</b>	3.23 m	<b>10'7"</b>	3.54 m	<b>11'7"</b>	4.1 m	<b>13'5"</b>
Ground Clearance	494 mm	<b>20"</b>	442 mm	<b>17.4"</b>	549 mm	<b>22"</b>	478 mm	<b>18.8"</b>
Fuel Tank Capacity	380 L	<b>100 U.S. gal</b>	479 L	<b>127 U.S. gal</b>	712 L	<b>188 U.S. gal</b>	1074 L	<b>284 U.S. gal</b>
Hydraulic Tank Capacity	110 L	<b>29 U.S. gal</b>	125 L	<b>33 U.S. gal</b>	267 L	<b>70 U.S. gal</b>	174 L†	<b>46 U.S. gal</b>
Hydraulic System Capacity (includes tank)	200 L	<b>52 U.S. gal</b>	250 L	<b>66 U.S. gal</b>	470 L	<b>124 U.S. gal</b>	435 L†	<b>115 U.S. gal</b>

\*Changes in bucket weight, including field installed wear iron, can impact rated payload. Consult your Cat dealer for assistance in selecting and configuring the proper bucket for the application. The Cat Large Wheel Loader Payload Policy is a guideline intended to maximize wheel loader structural and component life. The Cat Payload Policy is that the "Gross Bucket plus Payload Capacity" is the MAXIMUM weight that should be carried on the end of the Lift Arm/Boom.

†990H has a separate hydraulic system for steering and engine cooling fan. System (including tank) 194 L (51 U.S. gal), tank only 132 L (35 U.S. gal).

# Wheel Loaders Integrated Toolcarriers

## Specifications



MODEL	992K		993K		994F	
Flywheel Power: Net	597 kW	801 hp	705 kW	945 hp	1092 kW	1463 hp
Max.	674 kW	904 hp	783 kW	1050 hp	1176 kW	1577 hp
Rated Payload*	—		22.7 t	25 T	35 t STD	38 T
					32 t H.L.	35 T
					32 t SHL	35 T
Gross Rated Bucket Payload*	29 600 kg	65,300 lb	37 600 kg	82,900 lb	55 800 kg STD	123,000 lb
					53 100 kg H.L.	117,000 lb
					53 100 kg SHL	117,000 lb
Engine Model	C32 ACERT		C32 ACERT		3516B HHD EUI	
Rated Engine RPM	1750		1900		1600	
Bore	145 mm	5.7"	145 mm	5.7"	170 mm	6.7"
Stroke	162 mm	6.4"	162 mm	6.4"	215 mm	8.5"
No. Cylinders	12		12		16	
Displacement	32.1 L	1959 in <sup>3</sup>	32.1 L	1959 in <sup>3</sup>	78 L	4875 in <sup>3</sup>
Speeds Forward	km/h	mph	km/h	mph	km/h	mph
1st	7.1	4.4	7.0	4.3	7.7	4.8
2nd	12.2	7.6	11.5	7.1	13.4	8.3
3rd	20.6	12.8	19.6	12.2	22.5	14.0
Speeds Reverse						
1st	7.4	4.6	7.6	4.7	8.5	5.3
2nd	13.0	8.1	12.9	8.0	13.2	8.2
3rd	22.4	13.9	21.8	13.5	24.8	15.4
Hydraulic Cycle Time, Rated Load in Bucket:	Seconds		Seconds		Seconds	
Raise	9.4		9.4		11.3	
Dump	1.8		2.1		3.1	
Lower (Empty, Float Down)	3.7		3.7		3.5	
Total	14.9		15.2		17.9	
Tread Width	3.3 m	10'10"	3.54 m	11'6"	4.1 m	13'5"
Width Over Tires	4.5 m	14'9"	4.93 m	16'2"	5.45 m	17'11"
Ground Clearance	682 mm	26.8"	783 mm	30.8"	825 mm	32"
Fuel Tank Capacity	1610 L	425 U.S. gal	2170 L	573 U.S. gal	3833 L	1013 U.S. gal
Hydraulic Systems:						
Lift, Tilt	646 L	171 U.S. gal	755 L	199 U.S. gal	690 L	170 U.S. gal
Tank Only	326 L	86 U.S. gal	475 L	125.5 U.S. gal	390 L	103 U.S. gal
Steering and Brakes	231 L	61 U.S. gal	227 L	60 U.S. gal	267 L	71 U.S. gal
Tank Only	159 L	42 U.S. gal	185 L	48.9 U.S. gal	208 L	55 U.S. gal
Brake Cooling	—		—		42 L	11 U.S. gal
Tank Only	—		—		36 L	9.5 U.S. gal

\*Changes in bucket weight, including field installed wear iron, can impact rated payload. Consult your Cat dealer for assistance in selecting and configuring the proper bucket for the application. The Cat Large Wheel Loader Payload Policy is a guideline intended to maximize wheel loader structural and component life. The Cat Payload Policy is that the "Gross Bucket plus Payload Capacity" is the MAXIMUM weight that should be carried on the end of the Lift Arm/Boom.

Bucket Type	Ground Engaging Type	General Purpose			Multi-Purpose			Light Material
		Bare	Bolt-on Edges	Bolt-on Teeth	Bare	Bolt-on Edges	Bolt-on Teeth	Bolt-on Edges
Rated bucket capacity (\$)	m <sup>3</sup>	0.6	0.6	0.6	0.6	0.6	0.6	1.0
	yd <sup>3</sup>	<b>0.78</b>	<b>0.78</b>	<b>0.78</b>	<b>0.78</b>	<b>0.78</b>	<b>0.78</b>	<b>1.31</b>
Struck capacity (\$)	m <sup>3</sup>	0.48	0.48	0.48	0.48	0.48	0.48	0.74
	yd <sup>3</sup>	<b>0.63</b>	<b>0.63</b>	<b>0.63</b>	<b>0.63</b>	<b>0.63</b>	<b>0.63</b>	<b>0.97</b>
Bucket width	mm	1780	1790	1780	1780	1790	1780	1890
	ft/in	<b>5'10"</b>	<b>5'11"</b>	<b>5'10"</b>	<b>5'10"</b>	<b>5'11"</b>	<b>5'10"</b>	<b>6'3"</b>
Dump clearance at full lift and 45° discharge (\$)	mm	2377	2343	2377	2382	2348	2382	2191
	ft/in	<b>7'10"</b>	<b>7'9"</b>	<b>7'10"</b>	<b>7'10"</b>	<b>7'9"</b>	<b>7'10"</b>	<b>7'3"</b>
Reach at full lift and 45° discharge (\$)	mm	664	677	664	669	681	669	801
	ft/in	<b>2'2"</b>	<b>2'3"</b>	<b>2'2"</b>	<b>2'2"</b>	<b>2'3"</b>	<b>2'2"</b>	<b>2'8"</b>
Reach at 45° discharge and 2130 mm (7'0") clearance (\$)	mm	917	895	917	952	—	952	—
	ft/in	<b>3'0"</b>	<b>2'11"</b>	<b>3'0"</b>	<b>3'2"</b>	—	<b>3'2"</b>	—
Reach with lift arms horizontal and bucket level	mm	1869	1902	1869	1874	1907	1874	2103
	ft/in	<b>6'2"</b>	<b>6'3"</b>	<b>6'2"</b>	<b>6'2"</b>	<b>6'3"</b>	<b>6'2"</b>	<b>6'11"</b>
Digging depth (\$)	mm	91	107	91	58	74	58	100
	in	<b>3.6</b>	<b>4.2</b>	<b>3.6</b>	<b>2.3</b>	<b>2.9</b>	<b>2.3</b>	<b>3.9</b>
Overall length	mm	4693	4739	4693	4678	4726	4678	4940
	ft/in	<b>15'5"</b>	<b>15'7"</b>	<b>15'5"</b>	<b>15'5"</b>	<b>15'7"</b>	<b>15'5"</b>	<b>16'3"</b>
Overall height with bucket at full raise (\$)	mm	3996	3996	3996	3949	3949	3949	4285
	ft/in	<b>13'2"</b>	<b>13'2"</b>	<b>13'2"</b>	<b>13'0"</b>	<b>13'0"</b>	<b>13'0"</b>	<b>14'1"</b>
Loader clearance circle with bucket in carry position	mm	3838	3859	3838	3840	3860	3840	3969
	ft/in	<b>12'8"</b>	<b>12'8"</b>	<b>12'8"</b>	<b>12'8"</b>	<b>12'8"</b>	<b>12'8"</b>	<b>13'1"</b>
Static tipping load, straight* (\$)	kg	3085	3043	3068	2932	2890	2914	2962
	lb	<b>6801</b>	<b>6709</b>	<b>6764</b>	<b>6464</b>	<b>6371</b>	<b>6424</b>	<b>6530</b>
Static tipping load, full turn* (\$)	kg	2608	2566	2590	2455	2412	2437	2485
	lb	<b>5750</b>	<b>5657</b>	<b>5710</b>	<b>5412</b>	<b>5318</b>	<b>5373</b>	<b>5478</b>
Breakout force (\$)	kN	32.7	33.0	32.8	33.9	34.2	34.0	33.8
	lb	<b>7356</b>	<b>7424</b>	<b>7379</b>	<b>7626</b>	<b>7694</b>	<b>7648</b>	<b>7604</b>
Operating weight*	kg	4468	4502	4482	4639	4673	4653	4578
	lb	<b>9850</b>	<b>9925</b>	<b>9881</b>	<b>10,227</b>	<b>10,302</b>	<b>10,258</b>	<b>10,093</b>

\*Static tipping load and operating weights shown are with implements, cab, air conditioning, 12-16.5 tires, full fuel tank, operator and 75 kg (165 lb) counterweight.

NOTE: Specifications and ratings conform to all applicable standards recommended by the Society of Automotive Engineers (SAE). SAE Standards J732 JUN92 and J742 FEB85 govern loader rating, denoted in the text by (\$).

	Change in Operating Weight		Change in Articulated Static Tipping Load	
	kg	lb	kg	lb
OROPS/No HVAC .....	-150	-330	-130	-287
Remote oil cooler .....	+ 30	+ 66	- 32	- 71
Ride control .....	+ 12	+ 26	+ 1	+ 2



# Wheel Loaders Integrated Toolcarriers

## Performance Data

- 906H
- Vertical Coupler

Bucket Type	General Purpose			Multi-Purpose			Light Material	
		Bare	Bolt-on Edges	Bolt-on Teeth	Bare	Bolt-on Edges	Bolt-on Teeth	Bolt-on Edges
Ground Engaging Type	m <sup>3</sup>	0.9	0.9	0.9	0.75	0.75	0.75	1.2
	yd <sup>3</sup>	<b>1.18</b>	<b>1.18</b>	<b>1.18</b>	<b>1.0</b>	<b>1.0</b>	<b>1.0</b>	<b>1.56</b>
Struck capacity (\$)	m <sup>3</sup>	0.75	0.75	0.75	0.6	0.6	0.6	1.0
	yd <sup>3</sup>	<b>1.0</b>	<b>1.0</b>	<b>1.0</b>	<b>0.8</b>	<b>0.8</b>	<b>0.8</b>	<b>1.31</b>
Bucket width	mm	1880	1890	1880	1880	1890	1880	2080
	ft/in	<b>6'2"</b>	<b>6'2"</b>	<b>6'2"</b>	<b>6'2"</b>	<b>6'2"</b>	<b>6'2"</b>	<b>6'10"</b>
Dump clearance at full lift and 45° discharge (\$)	mm	2393	2359	2393	2468	2434	2468	2395
	ft/in	<b>7'8"</b>	<b>7'8"</b>	<b>7'8"</b>	<b>8'1"</b>	<b>8'0"</b>	<b>8'1"</b>	<b>7'10"</b>
Reach at full lift and 45° discharge (\$)	mm	809	820	809	758	770	758	803
	ft/in	<b>2'8"</b>	<b>2'8"</b>	<b>2'8"</b>	<b>2'6"</b>	<b>2'6"</b>	<b>2'6"</b>	<b>2'8"</b>
Reach at 45° discharge and 2130 mm (7'0") clearance (\$)	mm	1035	1050	1035	970	986	970	1030
	ft/in	<b>2'8"</b>	<b>2'8"</b>	<b>2'8"</b>	<b>2'8"</b>	<b>2'8"</b>	<b>2'8"</b>	<b>3'5"</b>
Reach with lift arms horizontal and bucket level	mm	2000	2033	2000	1919	1952	1919	2144
	ft/in	<b>6'7"</b>	<b>6'8"</b>	<b>6'7"</b>	<b>6'4"</b>	<b>6'5"</b>	<b>6'4"</b>	<b>7'0"</b>
Digging depth (\$)	mm	91	107	91	85	101	85	104
	in	<b>3.6</b>	<b>4.2</b>	<b>3.6</b>	<b>3.3</b>	<b>4.0</b>	<b>3.3</b>	<b>4.0</b>
Overall length	mm	5586	5620	5586	5497	5530	5497	5730
	ft/in	<b>18'4"</b>	<b>18'4"</b>	<b>18'4"</b>	<b>18'0"</b>	<b>18'2"</b>	<b>18'0"</b>	<b>18'10"</b>
Overall height with bucket at full raise (\$)	mm	4192	4192	4192	4176	4176	4176	4257
	ft/in	<b>13'9"</b>	<b>13'9"</b>	<b>13'9"</b>	<b>13'8"</b>	<b>13'8"</b>	<b>13'8"</b>	<b>14'0"</b>
Loader clearance circle with bucket in carry position	mm	8890	8928	8890	8832	8868	8832	9132
	ft/in	<b>29'2"</b>	<b>29'3"</b>	<b>29'2"</b>	<b>29'0"</b>	<b>29'1"</b>	<b>29'0"</b>	<b>30'0"</b>
Static tipping load, straight* (\$)	kg	3985	3841	3925	4065	3937	4010	3688
	lb	<b>8787</b>	<b>8469</b>	<b>8655</b>	<b>8963</b>	<b>8681</b>	<b>8842</b>	<b>8132</b>
Static tipping load, full turn* (\$)	kg	3159	3036	3107	3197	3087	3149	2898
	lb	<b>6966</b>	<b>6694</b>	<b>6851</b>	<b>7049</b>	<b>6807</b>	<b>6944</b>	<b>6390</b>
Breakout force (\$)	kN	42	41	38	47	45	42	38
	lb	<b>9440</b>	<b>9216</b>	<b>8541</b>	<b>10,564</b>	<b>10,115</b>	<b>9440</b>	<b>8541</b>
Operating weight*	kg	5629	5663	5642	5755	5789	5768	5733
	lb	<b>12,412</b>	<b>12,487</b>	<b>12,441</b>	<b>12,690</b>	<b>12,765</b>	<b>12,718</b>	<b>12,641</b>

\*Static tipping load and operating weights shown are with implements, ROPS cab, 12.5-20 tires, full fuel tank, operator and 80 kg (176 lb) counterweight.

NOTE: Specifications and ratings conform to all applicable standards recommended by the Society of Automotive Engineers (SAE). SAE Standards J732 JUN92 and J742 FEB85 govern loader rating, denoted in the text by (\$).

	Change in Operating Weight		Change in Articulated Static Tipping Load	
	kg	lb	kg	lb
35 km/h (22 mph) transmission	+ 101	+ 223	+ 30	+ 66
Cab — Standard	0	0	0	0
Cab — Comfort	0	0	0	0
Cab — Deluxe	0	0	0	0
OOPS/No HVAC	- 125	- 276	- 117	- 258
Ride control	+ 12	+ 27	+ 3	+ 7
Cylinder check valves	+ 9	+ 20	+ 1	+ 2
Air conditioning	+ 32	+ 71	+ 44	+ 97

Bucket Type	General Purpose			Multi-Purpose			Light Material	
		Bare	Bolt-on Edges	Bolt-on Teeth	Bare	Bolt-on Edges	Bolt-on Teeth	Bolt-on Edges
<b>Ground Engaging Type</b>								
Rated bucket capacity (\$)	m <sup>3</sup> yd <sup>3</sup>	0.9 <b>1.18</b>	0.9 <b>1.18</b>	0.9 <b>1.18</b>	0.75 <b>0.98</b>	0.75 <b>0.98</b>	0.75 <b>0.98</b>	1.2 <b>1.56</b>
Struck capacity (\$)	m <sup>3</sup> yd <sup>3</sup>	0.75 <b>0.98</b>	0.75 <b>0.98</b>	0.75 <b>0.98</b>	0.6 <b>0.78</b>	0.6 <b>0.78</b>	0.6 <b>0.78</b>	1.0 <b>1.31</b>
Bucket width	mm ft/in	1880 <b>6'2"</b>	1890 <b>6'2"</b>	1880 <b>6'2"</b>	1880 <b>6'2"</b>	1890 <b>6'2"</b>	1880 <b>6'2"</b>	2080 <b>6'10"</b>
Dump clearance at full lift and 45° discharge (\$)	mm ft/in	2513 <b>8'3"</b>	2478 <b>8'2"</b>	2437 <b>8'0"</b>	2500 <b>8'2"</b>	2465 <b>8'1"</b>	2428 <b>8'0"</b>	2429 <b>8'0"</b>
Reach at full lift and 45° discharge (\$)	mm ft/in	714 <b>2'4"</b>	725 <b>2'5"</b>	785 <b>2'7"</b>	704 <b>2'4"</b>	715 <b>2'4"</b>	775 <b>2'7"</b>	792 <b>2'7"</b>
Reach at 45° discharge and 2130 mm (7'0") clearance (\$)	mm ft/in	914 <b>3'0"</b>	928 <b>3'1"</b>	1005 <b>3'4"</b>	901 <b>2'11"</b>	915 <b>3'0"</b>	992 <b>3'3"</b>	1014 <b>3'4"</b>
Reach with lift arms horizontal and bucket level	mm ft/in	1851 <b>6'1"</b>	1883 <b>6'2"</b>	1953 <b>6'5"</b>	1858 <b>6'1"</b>	1891 <b>6'2"</b>	1960 <b>6'5"</b>	1994 <b>6'7"</b>
Digging depth (\$)	mm in	79 <b>3.0</b>	95 <b>4.0</b>	79 <b>3.0</b>	90 <b>4.0</b>	106 <b>4.0</b>	90 <b>4.0</b>	83 <b>3.3</b>
Overall length	mm ft/in	5436 <b>17'10"</b>	5469 <b>17'11"</b>	5538 <b>18'2"</b>	5436 <b>17'10"</b>	5436 <b>17'10"</b>	5538 <b>18'2"</b>	5580 <b>18'4"</b>
Overall height with bucket at full raise (\$)	mm ft/in	4077 <b>13'5"</b>	4077 <b>13'5"</b>	4077 <b>13'5"</b>	4134 <b>13'7"</b>	4134 <b>13'7"</b>	4134 <b>13'7"</b>	4141 <b>13'7"</b>
Loader clearance circle with bucket in carry position	mm ft/in	8802 <b>28'11"</b>	8840 <b>29'0"</b>	8784 <b>28'10"</b>	8812 <b>28'11"</b>	8848 <b>29'0"</b>	8792 <b>28'10"</b>	9042 <b>29'8"</b>
Static tipping load, straight* (\$)	kg lb	4283 <b>9442</b>	4123 <b>9090</b>	4215 <b>9292</b>	4167 <b>9187</b>	4069 <b>8971</b>	4088 <b>9012</b>	3892 <b>8580</b>
Static tipping load, full turn* (\$)	kg lb	3400 <b>7496</b>	3264 <b>7196</b>	3342 <b>7368</b>	3276 <b>7222</b>	3196 <b>7046</b>	3204 <b>7064</b>	3051 <b>6726</b>
Breakout force (\$)	kN lb	51 <b>11,463</b>	49 <b>11,014</b>	45 <b>10,115</b>	52 <b>11,688</b>	49 <b>11,014</b>	45 <b>10,115</b>	43 <b>9665</b>
Operating weight*	kg lb	5636 <b>12,425</b>	5670 <b>12,500</b>	5649 <b>12,454</b>	5796 <b>12,778</b>	5830 <b>12,853</b>	5809 <b>12,807</b>	5741 <b>12,657</b>

\*Static tipping load and operating weights shown are with implements, ROPS cab, 12.5-20 tires, full fuel tank, operator and 80 kg (176 lb) counterweight.

NOTE: Specifications and ratings conform to all applicable standards recommended by the Society of Automotive Engineers (SAE). SAE Standards J732 JUN92 and J742 FEB85 govern loader rating, denoted in the text by (\$).

	Change in Operating Weight		Change in Articulated Static Tipping Load	
	kg	lb	kg	lb
35 km/h (22 mph) transmission	+ 101	+ 223	+ 30	+ 66
Cab — Standard	0	0	0	0
Cab — Comfort	0	0	0	0
Cab — Deluxe	0	0	0	0
OOPS/No HVAC	- 125	- 276	- 117	- 258
Ride control	+ 12	+ 27	+ 3	+ 7
Cylinder check valves	+ 9	+ 20	+ 1	+ 2
Air conditioning	+ 32	+ 71	+ 44	+ 97

# Wheel Loaders Integrated Toolcarriers

## Performance Data

- 907H
- Vertical Coupler

Bucket Type	General Purpose			Multi-Purpose			Light Material	
		Bare	Bolt-on Edges	Bolt-on Teeth	Bare	Bolt-on Edges	Bolt-on Teeth	Bolt-on Edges
<b>Ground Engaging Type</b>								
Rated bucket capacity (\$)	m <sup>3</sup> yd <sup>3</sup>	1.0 1.31	1.0 1.31	1.0 1.31	0.75 1.0	0.75 1.0	0.75 1.0	1.2 1.56
Struck capacity (\$)	m <sup>3</sup> yd <sup>3</sup>	0.8 1.05	0.8 1.05	0.8 1.05	0.6 0.8	0.6 0.8	0.6 0.8	1.0 1.31
Bucket width	mm ft/in	2035 6'8"	2045 6'9"	2035 6'8"	1880 6'2"	1890 6'2"	1880 6'2"	2080 6'10"
Dump clearance at full lift and 45° discharge (\$)	mm ft/in	2393 7'10"	2359 7'9"	2321 7'7"	2468 8'1"	2434 8'0"	2397 7'10"	2395 7'10"
Reach at full lift and 45° discharge (\$)	mm ft/in	809 2'8"	820 2'8"	880 2'11"	758 2'6"	770 2'6"	830 2'9"	803 2'8"
Reach at 45° discharge and 2130 mm (7'0") clearance (\$)	mm ft/in	1035 3'5"	1050 3'5"	1100 3'7"	970 3'2"	986 3'3"	1036 3'5"	1027 3'4"
Reach with lift arms horizontal and bucket level	mm ft/in	2000 6'7"	2033 6'8"	2102 6'11"	1919 6'4"	1952 6'5"	2021 6'8"	2144 7'0"
Digging depth (\$)	mm in	91 3.6	107 4.2	91 3.6	85 3.4	101 4.0	85 3.4	104 4.1
Overall length	mm ft/in	5586 18'4"	5620 18'5"	5690 18'8"	5497 18'0"	5530 18'2"	5599 18'4"	5730 18'10"
Overall height with bucket at full raise (\$)	mm ft/in	4192 13'9"	4192 13'9"	4192 13'9"	4176 13'8"	4176 13'8"	4176 13'8"	4257 14'0"
Loader clearance circle with bucket in carry position	mm ft/in	9030 29'8"	9068 29'9"	9016 29'7"	8832 29'0"	8868 29'1"	8812 28'11"	9132 30'0"
Static tipping load, straight* (\$)	kg lb	4319 9523	4160 9173	4251 9373	4433 9775	4298 9477	4375 9647	4023 8871
Static tipping load, full turn* (\$)	kg lb	3168 6985	3038 6699	3112 6862	3223 7107	3113 6864	3176 7003	2922 6443
Breakout force (\$)	kN lb	42 9440	41 9216	38 8541	47 10,564	45 10,115	42 9440	38 8541
Operating weight*	kg lb	5821 12,835	5859 12,919	5838 12,873	5926 13,067	5960 13,142	5939 13,095	5904 13,018

\*Static tipping load and operating weights shown are with implements, ROPS cab, 12.5-20 tires, full fuel tank, operator and 80 kg (176 lb) counterweight.

**NOTE:** Specifications and ratings conform to all applicable standards recommended by the Society of Automotive Engineers (SAE). SAE Standards J732 JUN92 and J742 FEB85 govern loader rating, denoted in the text by (\$).

	Change in Operating Weight		Change in Articulated Static Tipping Load	
	kg	lb	kg	lb
35 km/h (22 mph) transmission	+ 101	+ 223	+ 30	+ 66
Cab — Standard	0	0	0	0
Cab — Comfort	0	0	0	0
Cab — Deluxe	0	0	0	0
O/OPS/No HVAC	- 125	- 276	- 117	- 258
Ride control	+ 12	+ 27	+ 3	+ 7
Cylinder check valves	+ 9	+ 20	+ 1	+ 2
Air conditioning	+ 32	+ 71	+ 44	+ 97

Bucket Type	General Purpose			Multi-Purpose			Light Material	
		Bare	Bolt-on Edges	Bolt-on Teeth	Bare	Bolt-on Edges	Bolt-on Teeth	Bolt-on Edges
<b>Ground Engaging Type</b>								
Rated bucket capacity (\$)	m <sup>3</sup> yd <sup>3</sup>	1.0 1.31	1.0 1.31	1.0 1.31	0.75 0.98	0.75 0.98	0.75 0.98	1.2 1.56
Struck capacity (\$)	m <sup>3</sup> yd <sup>3</sup>	0.75 0.98	0.75 0.98	0.75 0.98	0.6 0.78	0.6 0.78	0.6 0.78	1.0 1.31
Bucket width	mm ft/in	2035 6'8"	2045 6'9"	2035 6'8"	1880 6'2"	1890 6'2"	1880 6'2"	2080 6'10"
Dump clearance at full lift and 45° discharge (\$)	mm ft/in	2513 8'3"	2478 8'2"	2437 8'0"	2500 8'2"	2465 8'1"	2428 8'0"	2429 8'0"
Reach at full lift and 45° discharge (\$)	mm ft/in	714 2'4"	725 2'5"	785 2'7"	704 2'4"	715 2'4"	775 2'7"	792 2'7"
Reach at 45° discharge and 2130 mm (7'0") clearance (\$)	mm ft/in	914 3'0"	928 3'1"	1005 3'4"	900 2'11"	915 3'0"	992 3'3"	1014 3'4"
Reach with lift arms horizontal and bucket level	mm ft/in	1851 6'1"	1883 6'2"	1953 6'5"	1858 6'1"	1891 6'2"	1960 6'5"	1994 6'7"
Digging depth (\$)	mm in	79 3.1	95 3.7	79 3.1	90 3.5	106 4.2	90 3.5	83 3.0
Overall length	mm ft/in	5436 17'10"	5469 17'11"	5538 18'2"	5436 17'10"	5469 17'11"	5538 18'2"	5580 18'4"
Overall height with bucket at full raise (\$)	mm ft/in	4077 13'5"	4077 13'5"	4077 13'5"	4134 13'7"	4134 13'7"	4134 13'7"	4141 13'7"
Loader clearance circle with bucket in carry position	mm ft/in	8946 29'4"	8978 29'5"	8784 28'10"	8812 28'11"	8848 29'0"	8792 28'10"	9042 29'8"
Static tipping load, straight* (\$)	kg lb	4641 10,232	4465 9844	4565 10,064	4545 10,020	4400 9700	4487 9892	4317 9517
Static tipping load, full turn* (\$)	kg lb	3411 7520	3268 7205	3350 7385	3303 7282	3185 7022	3256 7178	3144 6931
Breakout force (\$)	kN lb	51 11,463	49 11,014	45 10,115	52 11,688	49 11,014	45 10,115	43 9665
Operating weight*	kg lb	5821 12,833	5859 12,917	5838 12,871	5966 13,153	6000 13,228	5979 13,181	5911 13,032

\*Static tipping load and operating weights shown are with implements, ROPS cab, 12.5-20 tires, full fuel tank, operator and 80 kg (176 lb) counterweight.

NOTE: Specifications and ratings conform to all applicable standards recommended by the Society of Automotive Engineers (SAE). SAE Standards J732 JUN92 and J742 FEB85 govern loader rating, denoted in the text by (\$).

	Change in Operating Weight		Change in Articulated Static Tipping Load	
	kg	lb	kg	lb
35 km/h (22 mph) transmission	+ 101	+ 223	+ 30	+ 66
Cab — Standard	0	0	0	0
Cab — Comfort	0	0	0	0
Cab — Deluxe	0	0	0	0
OOPS/No HVAC	- 125	- 276	- 117	- 258
Ride control	+ 12	+ 27	+ 3	+ 7
Cylinder check valves	+ 9	+ 20	+ 1	+ 2
Air conditioning	+ 32	+ 71	+ 44	+ 97

# Wheel Loaders Integrated Toolcarriers

## Performance Data

- 908H
- Vertical Coupler

Bucket Type	General Purpose			Multi-Purpose			Light Material	
		Bare	Bolt-on Edges	Bolt-on Teeth	Bare	Bolt-on Edges	Bolt-on Teeth	Bolt-on Edges
<b>Ground Engaging Type</b>								
Rated bucket capacity (\$)	m <sup>3</sup> yd <sup>3</sup>	1.1 1.44	1.1 1.44	1.1 1.44	0.9 1.18	0.9 1.18	0.9 1.18	1.5 1.96
Struck capacity (\$)	m <sup>3</sup> yd <sup>3</sup>	0.9 1.18	0.9 1.18	0.9 1.18	0.75 1.0	0.75 1.0	0.75 1.0	1.25 1.64
Bucket width	mm ft/in	2060 6'9"	2080 6'10"	2060 6'9"	2060 6'9"	2080 6'10"	2060 6'9"	2080 6'10"
Dump clearance at full lift and 45° discharge (\$)	mm ft/in	2539 8'4"	2505 8'3"	2467 8'1"	2627 8'7"	2593 8'6"	2556 8'5"	2346 7'8"
Reach at full lift and 45° discharge (\$)	mm ft/in	854 2'10"	866 2'10"	926 3'0"	788 2'7"	800 2'7"	861 2'10"	1025 3'4"
Reach at 45° discharge and 2130 mm (7'0") clearance (\$)	mm ft/in	1093 3'7"	1109 3'8"	1169 3'10"	1010 3'4"	1024 3'4"	1085 3'7"	1312 4'4"
Reach with lift arms horizontal and bucket level	mm ft/in	2149 7'1"	2181 7'2"	2251 7'5"	2039 6'8"	2072 6'10"	2141 7'0"	2405 7'11"
Digging depth (\$)	mm in	93 3.7	109 4.3	93 3.7	101 4.0	117 4.6	101 4.0	109 4.3
Overall length	mm ft/in	5747 18'10"	5780 19'0"	5849 19'2"	5643 18'6"	5670 18'7"	5740 18'10"	6004 19'8"
Overall height with bucket at full raise (\$)	mm ft/in	4415 14'6"	4415 14'6"	4415 14'6"	4392 14'5"	4392 14'5"	4392 14'5"	4547 14'11"
Loader clearance circle with bucket in carry position	mm ft/in	9118 29'11"	9158 30'1"	9110 29'11"	9042 29'8"	9080 29'9"	9030 29'8"	9298 30'6"
Static tipping load, straight* (\$)	kg lb	4774 10,527	4613 10,172	4711 10,388	4908 10,822	4763 10,502	4854 10,703	4400 9702
Static tipping load, full turn* (\$)	kg lb	3408 7515	3280 7232	3358 7404	3472 7656	3355 7398	3428 7559	3103 6842
Breakout force (\$)	kN lb	47 10,564	46 10,339	43 9665	54 12,138	52 11,688	48 10,789	38 8541
Operating weight*	kg lb	6459 14,242	6497 14,326	6472 14,271	6589 14,529	6627 14,613	6602 14,557	6572 14,491

\*Static tipping load and operating weights shown are with implements, ROPS cab, 12.5-20 tires, full fuel tank, operator and 80 kg (176 lb) counterweight.

**NOTE:** Specifications and ratings conform to all applicable standards recommended by the Society of Automotive Engineers (SAE). SAE Standards J732 JUN92 and J742 FEB85 govern loader rating, denoted in the text by (\$).

	Change in Operating Weight		Change in Articulated Static Tipping Load	
	kg	lb	kg	lb
35 km/h (22 mph) transmission	+ 101	+ 223	+ 27	+ 60
Cab — Standard	0	0	0	0
Cab — Comfort	0	0	0	0
Cab — Deluxe	0	0	0	0
O/OPS/No HVAC	- 125	- 276	- 108	- 238
Ride control	+ 12	+ 27	+ 3	+ 7
Cylinder check valves	+ 9	+ 20	+ 1	+ 2
Air conditioning	+ 32	+ 71	+ 41	+ 90

Bucket Type	General Purpose			Multi-Purpose			Light Material	
		Bare	Bolt-on Edges	Bolt-on Teeth	Bare	Bolt-on Edges	Bolt-on Teeth	Bolt-on Edges
<b>Ground Engaging Type</b>								
Rated bucket capacity (\$)	m <sup>3</sup> yd <sup>3</sup>	1.1 1.44	1.1 1.44	1.1 1.44	0.9 1.18	0.95 1.24	0.9 1.18	1.5 1.96
Struck capacity (\$)	m <sup>3</sup> yd <sup>3</sup>	0.9 1.18	0.9 1.18	0.9 1.18	0.75 0.98	0.75 0.98	0.75 0.98	1.25 1.64
Bucket width	mm ft/in	2060 6'9"	2080 6'10"	2060 6'9"	2060 6'9"	2080 6'10"	2060 6'9"	2080 6'10"
Dump clearance at full lift and 45° discharge (\$)	mm ft/in	2653 8'8"	2620 8'7"	2583 8'6"	2665 8'9"	2624 8'7"	2586 8'6"	2463 8'1"
Reach at full lift and 45° discharge (\$)	mm ft/in	757 2'6"	770 2'6"	830 2'9"	737 2'5"	748 2'5"	811 2'8"	931 3'1"
Reach at 45° discharge and 2130 mm (7'0") clearance (\$)	mm ft/in	969 3'2"	986 3'3"	1062 3'6"	944 3'1"	957 3'2"	1038 3'5"	1191 3'11"
Reach with lift arms horizontal and bucket level	mm ft/in	1999 6'7"	2031 6'8"	2101 6'11"	1978 6'6"	2010 6'7"	2080 6'10"	2256 7'5"
Digging depth (\$)	mm in	85 3.3	101 4.0	85 3.3	94 3.7	110 4.3	94 3.7	101 4.0
Overall length	mm ft/in	5598 18'4"	5630 18'6"	5699 18'8"	5576 18'4"	5609 18'5"	5678 18'8"	5854 19'2"
Overall height with bucket at full raise (\$)	mm ft/in	4304 14'1"	4304 14'1"	4304 14'1"	4345 14'3"	4345 14'3"	4345 14'3"	4437 14'7"
Loader clearance circle with bucket in carry position	mm ft/in	9022 29'7"	9060 29'9"	9008 29'7"	9018 29'7"	9056 29'9"	9004 29'6"	9192 30'2"
Static tipping load, straight* (\$)	kg lb	5099 11,241	4923 10,853	5029 11,087	5012 11,050	4865 10,725	4959 10,933	4693 10,346
Static tipping load, full turn* (\$)	kg lb	3648 8042	3509 7736	3593 7921	3541 7807	3423 7546	3499 7714	3319 7317
Breakout force (\$)	kN lb	57 12,812	55 12,362	50 11,239	58 13,037	56 12,587	52 11,688	43 9665
Operating weight*	kg lb	6461 14,244	6499 14,328	6474 14,273	6616 14,586	6654 14,670	6629 14,614	6580 14,506

\*Static tipping load and operating weights shown are with implements, ROPS cab, 12.5-20 tires, full fuel tank, operator and 80 kg (176 lb) counterweight.

NOTE: Specifications and ratings conform to all applicable standards recommended by the Society of Automotive Engineers (SAE). SAE Standards J732 JUN92 and J742 FEB85 govern loader rating, denoted in the text by (\$).

	Change in Operating Weight		Change in Articulated Static Tipping Load	
	kg	lb	kg	lb
35 km/h (22 mph) transmission	+ 101	+ 223	+ 27	+ 60
Cab — Standard	0	0	0	0
Cab — Comfort	0	0	0	0
Cab — Deluxe	0	0	0	0
OOPS/No HVAC	- 125	- 276	- 108	- 238
Ride control	+ 12	+ 27	+ 3	+ 7
Cylinder check valves	+ 9	+ 20	+ 1	+ 2
Air conditioning	+ 32	+ 71	+ 41	+ 90

Bucket Type	General Purpose							Penetration	
	Ground Engaging Type	Bolt-on Cutting Edges		Bolt-on Teeth & Segments		Bolt-on Teeth		Flush Mounted Teeth	
Rated bucket capacity (\$)	m <sup>3</sup> yd <sup>3</sup>	1.3 1.7	1.4 1.8	1.3 1.7	1.4 1.8	1.2 1.6	1.3 1.7	1.3 1.7	1.4 1.8
Struck capacity (\$)	m <sup>3</sup> yd <sup>3</sup>	1.1 1.4	1.2 1.5	1.1 1.4	1.2 1.5	1.0 1.3	1.1 1.5	1.1 1.5	1.2 1.5
Bucket width	mm ft/in	2401 7'10.5"	2401 7'10.5"	2424 7'11.4"	2424 7'11.4"	2424 7'11.4"	2424 7'11.4"	2434 7'11.8"	2434 7'11.8"
Dump clearance at full lift and 45° discharge (\$)	mm ft/in	2658 8'9"	2623 8'7"	2658 8'9"	2630 8'7"	2714 8'11"	2679 8'10"	2679 8'10"	2679 8'10"
Reach at full lift and 45° discharge (\$)	mm ft/in	973 3'2"	1008 3'4"	966 3'2"	1001 3'3"	943 3'1"	979 3'3"	979 3'3"	979 3'3"
Reach at 45° discharge and 2130 mm (7'0") clearance (\$)	mm ft/in	1330 4'4"	1348 4'5"	1282 4'2"	1297 4'3"	1259 4'2"	1275 4'2"	1287 4'3"	1249 4'1"
Reach with lift arms horizontal and bucket level	mm ft/in	1980 6'6"	2030 6'8"	1970 6'6"	2020 6'8"	1920 6'4"	1970 6'6"	1970 6'6"	1970 6'6"
Digging depth (\$)	mm in	89 3.5	89 3.5	89 3.5	89 3.5	70 2.8	70 2.8	70 2.8	70 2.8
Overall length	mm ft/in	6229 20'5"	6279 20'7"	6328 20'9"	6378 20'11"	6310 20'8"	6360 20'10"	6358 20'10"	6438 21'1"
Overall height with bucket at full raise (\$)	mm ft/in	4390 14'5"	4442 14'7"	4390 14'5"	4442 14'7"	4390 14'5"	4442 14'7"	4442 14'7"	4442 14'7"
Loader clearance circle with bucket in carry position	m ft/in	10.34 33'11"	10.37 34'0"	10.42 34'2"	10.45 34'4"	10.42 34'2"	10.45 34'4"	10.44 34'3"	10.49 34'5"
Static tipping load, straight* (\$)	kg lb	6098 13,446	6069 13,382	6059 13,360	6029 13,294	6169 13,603	6166 13,602	6183 13,634	6011 13,254
Static tipping load, full 40° turn* (\$)	kg lb	5323 11,737	5295 11,675	5284 11,651	5256 11,589	5415 11,940	5387 11,878	5404 11,916	5232 11,537
Breakout force (\$)	kg lb	6367 14,007	5971 13,136	6415 14,113	6010 13,222	6930 15,246	6469 14,232	6484 14,265	6374 14,055
Operating weight*	kg lb	7378 16,262	7391 16,297	7409 16,337	7422 16,366	7336 16,176	7349 16,205	7336 16,176	7500 16,538

\*Static tipping load and operating weights shown include lubricants, full fuel tank, ROPS cab, 80 kg (176 lb) operator and 17.5-R25 (L2 equivalent) tires.

**NOTE:** Specifications and ratings conform to all applicable standards recommended by the Society of Automotive Engineers (SAE). SAE Standards J732 JUN92 and J742 FEB85 govern loader rating, denoted in the text by (\$).

	Change in Operating Weight		Change in Articulated Static Tipping Load	
	kg	lb	kg	lb
Air conditioner	+ 55	+ 121	+ 71	+ 156
Canopy, ROPS (less cab)	- 199	- 438	- 174	- 383
Counterweight, 150 kg (330 lb)	+ 152	+ 334	+ 287	+ 631
Ride control	+ 32	+ 70	+ 6	+ 13
Supplemental steering	+ 30	+ 66	+ 44	+ 97
Tires & rims, 15.5-25, 12 PR (L-2)	- 159	- 351	- 99	- 218
Tires & rims, 15.5-25, 12 PR (L-3)	- 78	- 172	- 48	- 106
Tires & rims, 15.5-R25, Radial (L-2 equivalent)	- 84	- 185	- 52	- 114
Tires & rims, 15.5-R25, Radial (L-3 equivalent)	- 36	- 79	- 23	- 51
Tires & rims, 17.5-25, 12 PR (L-2)	- 126	- 277	- 78	- 172
Tires & rims, 17.5-25, 12 PR (L-3)	+ 12	+ 26	+ 7	+ 15
Tires & rims, 17.5-R25, Radial (L-3 equivalent)	+ 156	+ 343	+ 96	+ 211
Tires & rims, 17.5-R25, Radial (L-2/L-3 equivalent)	+ 95	+ 209	+ 58	+ 128

Performance Data  
 ● IT14G  
 ● General Purpose Buckets

Wheel Loaders  
 Integrated Toolcarriers

Bucket Type	General Purpose		
		Bolt-on Teeth	Corner Guard or Bolt-on Edge
Cutting Edge			
Heaped capacity	m <sup>3</sup>	1.2	1.3
	yd <sup>3</sup>	1.6	1.7
Struck capacity	m <sup>3</sup>	1.0	1.1
	yd <sup>3</sup>	1.3	1.4
Bucket width	mm	2424	2401
	ft/in	7'11.4"	7'10.5"
Dump clearance at full lift and 45° discharge	mm	2975	2920
	ft/in	9'9"	9'7"
Reach at 45° discharge and 2130 mm (7'0") clearance	mm	1351	1425
	ft/in	4'5"	4'8"
Reach at full lift and 45° discharge	mm	757	787
	ft/in	2'6"	2'7"
Reach with lift arms horizontal and bucket level	mm	2090	2150
	ft/in	6'10"	7'1"
Digging depth	mm	156	175
	in	6.1	6.9
Overall length	mm	6506	6424
	ft/in	21'4"	21'1"
Overall height with bucket at full raise	mm	4801	4801
	ft/in	15'9"	15'9"
Loader clearance circle with bucket in carry position	m	10.47	10.4
	ft/in	34'4"	34'1"
Static tipping load, straight**	kg	5637	5541
	lb	12,400	12,210
Static tipping load, full turn**	kg	4882	4792
	lb	10,760	10,560
Breakout force*	kN	82.9	77
	lb	18,640	17,340
Operating weight**	kg	7990	8032
	lb	17,620	17,770

\*Breakout force is measured 102 mm (4") behind tip of cutting edge with bucket hinge pin as pivot in accordance with SAE J732 JUN92.

\*\*Operating weight and static tipping load include lubricants, full fuel tank, ROPS cab and 80 kg (176 lb) operator.

— IT14G includes high speed version, standard counterweight and 17.5-R25 tires.

Machine stability is affected by the tire size, tire ballast and attachments.



# Wheel Loaders Integrated Toolcarriers

## Performance Data

- IT14G
- Pallet Forks
- Material Handling Arm

		Pallet Forks		
Fork tine length	mm ft/in	1050 3'5"	1200 3'11"	1350 4'5"
Ground to top of tine clearance	mm ft/in	3708 12'2"	3708 12'2"	3708 12'2"
Reach with lift arms horizontal and forks level	mm ft/in	1490 4'11"	1490 4'11"	1490 4'11"
Overall length	mm ft/in	6723 22'1"	6873 22'7"	7023 23'1"
Static tipping load, straight*	kg lb	4447 9800	4309 9500	4179 9200
Static tipping load, full turn*	kg lb	3853 8490	3734 8230	3620 7980
Operating weight* 4 forward, 3 reverse	kg lb	7898 17,400	7915 17,450	7928 17,480

\*Static tipping load and operating weight include lubricants, full fuel tank, ROPS cab and 80 kg (176 lb) operator.  
— IT14G includes high speed version, standard counterweight and 17.5R25 tires.

Machine stability and operating weight are affected by tire size, tire ballast and other attachments.

**NOTE:** The rated operating load for a machine with pallet fork is: SAE J1197 FEB91; 50% of full turn static tipping load, or hydraulic/structural limit. CEN 474-3: 60% of full turn static tipping load on rough terrain; 80% of full turn static tipping load on firm and level ground, or the hydraulic/structural limit.

		Material Handling Arm		
Handling Arm Position		Retracted	Mid-position	Extended
Operating load — full articulation	kg lb	1370 3021	1076 2373	888 1958
Static tipping load, straight*	kg lb	3158 6963	2484 5477	2051 4522
Static tipping load, full turn*	kg lb	2740 6042	2153 4747	1777 3918
Operating weight* 4 forward, 3 reverse	kg lb	7770 17,130	7770 17,130	7770 17,130

\*Static tipping load and operating weight include lubricants, full fuel tank, ROPS cab and 80 kg (176 lb) operator.  
— IT14G includes high speed version, standard counterweight and 17.5-R25 tires.

Machine stability and operating weight are affected by tire size, tire ballast and other attachments.

**NOTE:** The rated operating load for a machine with material handling arm is 50% of full turn static tipping load, or the hydraulic/structural limit.

Bucket Type	General Purpose						
	Ground Engaging Type	Bolt-on Cutting Edges		Bolt-on Teeth & Segments		Bolt-on Teeth	
Rated bucket capacity	m <sup>3</sup> yd <sup>3</sup>	1.8 2.3	2.1 2.7	1.8 2.3	2.1 2.7	1.7 2.2	2.0 2.6
Struck capacity	m <sup>3</sup> yd <sup>3</sup>	1.5 2.0	1.7 2.2	1.5 2.0	1.7 2.2	1.4 1.8	1.6 2.1
Bucket width	mm ft/in	2550 8'4"	2550 8'4"	2620 8'7"	2620 8'7"	2620 8'7"	2620 8'7"
Dump clearance at full lift and 45° discharge (°)	mm ft/in	2826 9'3"	2757 9'1"	2722 8'11"	2653 8'8"	2722 8'11"	2653 8'8"
Reach at full tilt and 45° discharge (°)	mm ft/in	791 2'7"	859 2'10"	894 2'11"	962 3'2"	894 2'11"	962 3'2"
Reach at 45° discharge and 2130 mm (7'0") clearance (°)	mm ft/in	1318 4'4"	1350 4'5"	1365 4'6"	1392 4'7"	1365 4'6"	1392 4'7"
Reach with lift arms horizontal and bucket level	mm ft/in	2059 6'9"	2156 7'1"	2205 7'3"	2302 7'7"	2205 7'3"	2302 7'7"
Digging depth (°)	mm in	43 1.7	51 2.0	56 2.2	64 2.5	56 2.2	64 2.5
Overall length	mm ft/in	6898 22'8"	7001 23'0"	7044 23'1"	7147 23'5"	7023 23'1"	7127 23'5"
Overall height with bucket at full raise (°)	mm ft/in	4809 15'9"	4936 16'2"	4809 15'9"	4936 16'2"	4809 15'9"	4936 16'2"
Loader clearance radius with bucket in carry position (°)	mm ft/in	5616 18'5"	5646 18'6"	5692 18'8"	5722 18'9"	5689 18'8"	5719 18'9"
Static tipping load straight (°)	kg lb	8816 19,437	8732 19,251	8653 19,077	8565 18,884	8757 19,306	8671 19,117
Static tipping load with 40° turn (°)	kg lb	7640 16,844	7560 16,667	7477 16,484	7393 16,299	7581 16,713	7499 16,533
Breakout force (°)	kg lb	9954 21,945	8975 19,787	9833 21,678	8854 19,520	10 734 23,665	9604 21,173
Operating weight	kg lb	10 968 24,180	11 021 24,297	11 104 24,480	11 156 24,595	11 018 24,291	11 071 24,408

NOTE: Specifications and ratings conform to all applicable standards recommended by the Society of Automotive Engineers (SAE). SAE Standards J732 JUN92 and J742 FEB85 govern loader rating, denoted in the text by (°).

	Change in Operating Weight		Change in Articulated Static Tipping Load	
	kg	lb	kg	lb
Without Air conditioner	- 32	- 70	- 29	- 64
Canopy, ROPS (less cab)	- 199	- 439	- 182	- 402
Without Optional Counterweights 340 kg (750 lb)	- 320	- 704	- 609	- 1340
Without Guard, crankcase	- 15	- 33	- 21	- 47
Without Guard, driveshaft	- 43	- 95	- 5	- 12
Without Guard, power train	- 52	- 114	- 51	- 113
Without Ride Control System	- 40	- 88	- 29	- 64
Without Secondary steering	- 37	- 81	- 33	- 73
<b>Tires, 1-piece rims</b>				
17.5-25, 12PR (L-2)	- 652	- 1437	- 408	- 900
17.5-25, 12PR (L-3)	- 580	- 1279	- 363	- 801
17.5-25, Radial (L-2)	- 612	- 1349	- 383	- 845
17.5-25, Radial (L-3)	- 512	- 1129	- 320	- 706
<b>Tires, 3-piece rims</b>				
17.5-25, 12PR (L-2)	- 528	- 1164	- 330	- 728
17.5-25, 12PR (L-3)	- 456	- 1005	- 285	- 629
17.5-25, Radial (L-2)	- 488	- 1076	- 305	- 673
17.5-25, Radial (L-3)	- 388	- 855	- 243	- 536
550/65 R25, Radial (L-2)	- 196	- 432	- 123	- 272
550/65 R25, Radial (L-3)	- 136	- 300	- 85	- 188
20.5-25, 12PR (L-2)	- 240	- 529	- 150	- 331
20.5-25, 12PR (L-3)	- 36	- 79	- 22	- 49
20.5 R25, Radial (L-2)	- 172	- 379	- 108	- 239
20.5 R25, Radial (L-3)	0	0	0	0

Bucket Type		General Purpose						Waste/Ag
		Bolt-on Cutting Edges		Bolt-on Teeth & Segments		Bolt-on Teeth		Bolt-on Cutting Edge
Rated bucket capacity	m <sup>3</sup>	1.8	2.1	1.8	2.1	1.7	2.0	2.8
	yd <sup>3</sup>	2.3	2.7	2.3	2.7	2.2	2.6	3.6
Struck capacity	m <sup>3</sup>	1.5	1.7	1.5	1.7	1.4	1.6	2.3
	yd <sup>3</sup>	2.0	2.2	2.0	2.2	1.8	2.1	3.0
Bucket width	mm	2550	2550	2620	2620	2620	2620	2550
	ft/in	8'4"	8'4"	8'7"	8'7"	8'7"	8'7"	8'4"
Dump clearance at full lift and 45° discharge (°)	mm	2918	2849	2814	2745	2814	2745	2712
	ft/in	9'7"	9'4"	9'3"	9'0"	9'3"	9'0"	8'11"
Reach at full tilt and 45° discharge (°)	mm	885	957	988	1060	988	1060	1091
	ft/in	2'11"	3'2"	3'3"	3'6"	3'3"	3'6"	3'7"
Reach at 45° discharge and 2130 mm (7'0") clearance (°)	mm	1453	1491	1505	1539	1505	1539	1551
	ft/in	4'9"	4'11"	4'11"	5'1"	4'11"	5'1"	5'1"
Reach with lift arms horizontal and bucket level	mm	2156	2255	2302	2401	2302	2401	2446
	ft/in	7'1"	7'5"	7'7"	7'11"	7'7"	7'11"	8'0"
Digging depth (°)	mm	64	70	77	83	77	83	89
	in	2.5	2.8	3.0	3.3	3.0	3.3	3.5
Overall length	mm	7007	7112	7153	7258	7130	7235	7320
	ft/in	23'0"	23'4"	23'6"	23'10"	23'5"	23'9"	24'0"
Overall height with bucket at full raise (°)	mm	4966	5095	4966	5095	4966	5095	5216
	ft/in	16'4"	16'9"	16'4"	16'9"	16'4"	16'9"	17'1"
Loader clearance radius with bucket in carry position (°)	mm	5530	5558	5605	5634	5605	5634	5693
	ft/in	18'3"	18'3"	18'3"	18'3"	18'3"	18'3"	18'3"
Static tipping load straight (°)	kg	8738	8557	8577	8393	8679	8497	7459
	lb	19,265	18,866	18,909	18,503	19,135	18,733	16,444
Static tipping load with 40° turn (°)	kg	7666	7490	7504	7325	7607	7430	6520
	lb	16,900	16,512	16,544	16,149	16,770	16,379	14,374
Breakout force (°)	kg	11 336	10 250	11 215	10 129	12 118	10 878	7389
	lb	24,992	22,597	24,725	22,331	26,716	23,982	16,290
Operating weight	kg	11 379	11 515	11 514	11 650	11 429	11 565	11 472
	lb	25,087	25,386	25,384	25,684	25,197	25,497	25,292

**NOTE:** Specifications and ratings conform to all applicable standards recommended by the Society of Automotive Engineers (SAE). SAE Standards J732 JUN92 and J742 FEB85 govern loader rating, denoted in the text by (°).

	Change in Operating Weight		Change in Articulated Static Tipping Load	
	kg	lb	kg	lb
Without Air conditioner	- 32	- 70	- 27	- 60
Canopy, ROPS (less cab)	- 199	- 439	- 166	- 366
Counterweight, 175 kg (385 lb) (removal)	- 175	- 386	- 273	- 602
Without Guard, crankcase	- 15	- 33	- 19	- 42
Without Guard, driveshaft	- 17	- 37	- 5	- 12
Without Guard, power train	- 52	- 114	- 47	- 104
Without Ride Control System	- 40	- 88	- 27	- 60
Without Secondary steering	- 37	- 81	- 31	- 69
<b>Tires, 1-piece rims</b>				
17.5-25, 12PR (L-2)	- 652	- 1437	- 371	- 818
17.5-25, 12PR (L-3)	- 580	- 1279	- 330	- 728
17.5-25, Radial (L-2)	- 612	- 1349	- 348	- 768
17.5-25, Radial (L-3)	- 512	- 1129	- 292	- 644
<b>Tires, 3-piece rims</b>				
17.5-25, 12PR (L-2)	- 528	- 1164	- 301	- 664
17.5-25, 12PR (L-3)	- 456	- 1005	- 260	- 574
17.5-25, Radial (L-2)	- 488	- 1076	- 278	- 613
17.5-25, Radial (L-3)	- 388	- 855	- 221	- 488
550/65 R25, Radial (L-2)	- 196	- 432	- 112	- 247
550/65 R25, Radial (L-3)	- 136	- 300	- 78	- 172
20.5-25, 12PR (L-2)	- 240	- 529	- 137	- 303
20.5-25, 12PR (L-3)	- 36	- 79	- 21	- 47
20.5 R25, Radial (L-2)	- 172	- 379	- 98	- 217
20.5 R25, Radial (L-3)	0	0	0	0

Bucket Type		General Purpose						Waste/Ag	
		Bolt-on Cutting Edges		Bolt-on Teeth & Segments		Bolt-on Teeth		Bolt-on Cutting Edge	
Ground Engaging Type	Rated bucket capacity	m <sup>3</sup>	1.8	2.1	1.8	2.1	1.7	2.0	2.8
		yd <sup>3</sup>	2.3	2.7	2.3	2.7	2.2	2.6	3.6
Struck capacity		m <sup>3</sup>	1.5	1.7	1.5	1.7	1.4	1.6	2.3
		yd <sup>3</sup>	2.0	2.2	2.0	2.2	1.8	2.1	3.0
Bucket width		mm	2550	2550	2620	2620	2620	2620	2550
		ft/in	8'4"	8'4"	8'7"	8'7"	8'7"	8'7"	8'4"
Dump clearance at full lift and 45° discharge (°)		mm	3426	3357	3322	3253	3322	3253	3219
		ft/in	11'3"	11'0"	10'11"	10'8"	10'11"	10'8"	10'7"
Reach at full tilt and 45° discharge (°)		mm	885	957	988	1060	988	1060	1091
		ft/in	2'11"	3'2"	3'3"	3'6"	3'3"	3'6"	3'7"
Reach at 45° discharge and 2130 mm (7'0") clearance (°)		mm	1877	1920	1937	1977	1937	1977	1993
		ft/in	6'2"	6'4"	6'4"	6'6"	6'4"	6'6"	6'6"
Reach with lift arms horizontal and bucket level		mm	2546	2645	2692	2791	2692	2791	2836
		ft/in	8'4"	8'8"	8'10"	9'2"	8'10"	9'2"	9'4"
Digging depth (°)		mm	74	80	87	93	87	93	99
		in	2.9	3.1	3.4	3.7	3.4	3.7	3.9
Overall length		mm	7509	7613	7655	7759	7637	7741	7817
		ft/in	24'8"	25'0"	25'1"	25'5"	25'1"	25'5"	25'8"
Overall height with bucket at full raise (°)		mm	5473	5603	5473	5603	5473	5603	5723
		ft/in	17'11"	18'5"	17'11"	18'5"	17'11"	18'5"	18'9"
Loader clearance radius with bucket in carry position (°)		mm	5785	5818	5866	5899	5866	5899	5986
		ft/in	18'3"	18'3"	18'3"	18'3"	18'3"	18'3"	18'3"
Static tipping load straight (°)		kg	7120	6954	6964	6795	7063	6896	6184
		lb	15,698	15,330	15,353	14,980	15,572	15,202	13,633
Static tipping load with 40° turn (°)		kg	6219	6056	6063	5897	6162	5998	5379
		lb	13,711	13,352	13,366	13,001	13,585	13,223	11,858
Breakout force (°)		kg	11 336	10 250	11 215	10 129	12 118	10 878	7389
		lb	24,992	22,597	24,725	22,331	26,716	23,982	16,290
Operating weight		kg	11 498	11 633	11 633	11 769	11 547	11 683	11 591
		lb	25,349	25,647	25,647	25,946	25,457	25,757	25,554

NOTE: Specifications and ratings conform to all applicable standards recommended by the Society of Automotive Engineers (SAE). SAE Standards J732 JUN92 and J742 FEB85 govern loader rating, denoted in the text by (°).

	Change in Operating Weight		Change in Articulated Static Tipping Load	
	kg	lb	kg	lb
Without Air conditioner	- 32	- 70	- 27	- 60
Canopy, ROPS (less cab)	- 199	- 439	- 166	- 366
Counterweight, 175 kg (385 lb) (removal)	- 175	- 386	- 273	- 602
Without Guard, crankcase	- 15	- 33	- 19	- 42
Without Guard, driveshaft	- 17	- 37	- 5	- 12
Without Guard, power train	- 52	- 114	- 47	- 104
Without Ride Control System	- 40	- 88	- 27	- 60
Without Secondary steering	- 37	- 81	- 31	- 69
<b>Tires, 1-piece rims</b>				
17.5-25, 12PR (L-2)	- 652	- 1437	- 371	- 818
17.5-25, 12PR (L-3)	- 580	- 1279	- 330	- 728
17.5-25, Radial (L-2)	- 612	- 1349	- 348	- 768
17.5-25, Radial (L-3)	- 512	- 1129	- 292	- 644
<b>Tires, 3-piece rims</b>				
17.5-25, 12PR (L-2)	- 528	- 1164	- 301	- 664
17.5-25, 12PR (L-3)	- 456	- 1005	- 260	- 574
17.5-25, Radial (L-2)	- 488	- 1076	- 278	- 613
17.5-25, Radial (L-3)	- 388	- 855	- 221	- 488
550/65 R25, Radial (L-2)	- 196	- 432	- 112	- 247
550/65 R25, Radial (L-3)	- 136	- 300	- 78	- 172
20.5-25, 12PR (L-2)	- 240	- 529	- 137	- 303
20.5-25, 12PR (L-3)	- 36	- 79	- 21	- 47
20.5 R25, Radial (L-2)	- 172	- 379	- 98	- 217
20.5 R25, Radial (L-3)	0	0	0	0

Bucket Type		General Purpose						Waste/Ag
		Bolt-on Cutting Edges		Bolt-on Teeth & Segments		Bolt-on Teeth		Bolt-on Cutting Edge
Rated bucket capacity	m <sup>3</sup>	1.8	2.1	1.8	2.1	1.7	2.0	2.8
	yd <sup>3</sup>	2.3	2.7	2.3	2.7	2.2	2.6	3.6
Struck capacity	m <sup>3</sup>	1.5	1.7	1.5	1.7	1.4	1.6	2.3
	yd <sup>3</sup>	2.0	2.2	2.0	2.2	1.8	2.1	3.0
Bucket width	mm	2550	2550	2620	2620	2620	2620	2550
	ft/in	8'4"	8'4"	8'7"	8'7"	8'7"	8'7"	8'4"
Dump clearance at full lift and 45° discharge (°)	mm	2828	2759	2724	2654	2724	2654	2622
	ft/in	9'3"	9'1"	8'11"	8'8"	8'11"	8'8"	8'7"
Reach at full tilt and 45° discharge (°)	mm	992	1060	1095	1164	1095	1164	1199
	ft/in	3'3"	3'6"	3'7"	3'10"	3'7"	3'10"	3'11"
Reach at 45° discharge and 2130 mm (7'0") clearance (°)	mm	1516	1548	1563	1591	1563	1591	1605
	ft/in	5'0"	5'1"	5'2"	5'3"	5'2"	5'3"	5'3"
Reach with lift arms horizontal and bucket level	mm	2296	2392	2442	2539	2442	2539	2586
	ft/in	7'6"	7'10"	8'0"	8'4"	8'0"	8'4"	8'6"
Digging depth (°)	mm	64	72	77	85	77	85	89
	in	2.5	2.8	3.0	3.3	3.0	3.3	3.5
Overall length	mm	7147	7251	7293	7398	7270	7375	7460
	ft/in	23'5"	23'9"	23'11"	24'3"	23'10"	24'2"	24'6"
Overall height with bucket at full raise (°)	mm	5067	5194	5067	5194	5067	5194	5326
	ft/in	16'7"	17'0"	16'7"	17'0"	16'7"	17'0"	17'6"
Loader clearance radius with bucket in carry position (°)	mm	5568	5597	5644	5675	5644	5675	5657
	ft/in	18'3"	18'3"	18'3"	18'3"	18'3"	18'3"	18'3"
Static tipping load straight (°)	kg	8310	8126	8149	7963	8251	8067	7965
	lb	18,320	17,916	17,966	17,556	18,191	17,784	17,559
Static tipping load with 40° turn (°)	kg	7276	7098	7115	6934	7217	7038	6953
	lb	16,041	15,647	15,687	15,287	15,911	15,516	15,328
Breakout force (°)	kg	9857	9003	9736	8882	10 432	9475	7733
	lb	21,731	19,848	21,464	19,582	22,999	20,889	17,048
Operating weight	kg	11 501	11 635	11 636	11 770	11 551	11 685	11 663
	lb	25,355	25,651	25,653	25,949	25,466	25,761	25,713

**NOTE:** Specifications and ratings conform to all applicable standards recommended by the Society of Automotive Engineers (SAE). SAE Standards J732 JUN92 and J742 FEB85 govern loader rating, denoted in the text by (°).

	Change in Operating Weight		Change in Articulated Static Tipping Load	
	kg	lb	kg	lb
Without Air conditioner	- 32	- 70	- 27	- 60
Canopy, ROPS (less cab)	- 199	- 439	- 166	- 366
Counterweight, 175 kg (385 lb) (removal)	- 175	- 386	- 273	- 602
Without Guard, crankcase	- 15	- 33	- 19	- 42
Without Guard, driveshaft	- 17	- 37	- 5	- 12
Without Guard, power train	- 52	- 114	- 47	- 104
Without Ride Control System	- 40	- 88	- 27	- 60
Without Secondary steering	- 37	- 81	- 31	- 69
<b>Tires, 1-piece rims</b>				
17.5-25, 12PR (L-2)	- 652	- 1437	- 371	- 818
17.5-25, 12PR (L-3)	- 580	- 1279	- 330	- 728
17.5-25, Radial (L-2)	- 612	- 1349	- 348	- 768
17.5-25, Radial (L-3)	- 512	- 1129	- 292	- 644
<b>Tires, 3-piece rims</b>				
17.5-25, 12PR (L-2)	- 528	- 1164	- 301	- 664
17.5-25, 12PR (L-3)	- 456	- 1005	- 260	- 574
17.5-25, Radial (L-2)	- 488	- 1076	- 278	- 613
17.5-25, Radial (L-3)	- 388	- 855	- 221	- 488
550/65 R25, Radial (L-2)	- 196	- 432	- 112	- 247
550/65 R25, Radial (L-3)	- 136	- 300	- 78	- 172
20.5-25, 12PR (L-2)	- 240	- 529	- 137	- 303
20.5-25, 12PR (L-3)	- 36	- 79	- 21	- 47
20.5 R25, Radial (L-2)	- 172	- 379	- 98	- 217
20.5 R25, Radial (L-3)	0	0	0	0

Bucket Type	General Purpose							Waste/Ag
	Ground Engaging Type	Bolt-on Cutting Edges		Bolt-on Teeth & Segments		Bolt-on Teeth		Bolt-on Cutting Edge
Rated bucket capacity	m <sup>3</sup> yd <sup>3</sup>	1.8 2.3	2.1 2.7	1.8 2.3	2.1 2.7	1.7 2.2	2.0 2.6	2.8 3.6
Struck capacity	m <sup>3</sup> yd <sup>3</sup>	1.5 2.0	1.7 2.2	1.5 2.0	1.7 2.2	1.4 1.8	1.6 2.1	2.3 3.0
Bucket width	mm ft/in	2550 8'4"	2550 8'4"	2620 8'7"	2620 8'7"	2620 8'7"	2620 8'7"	2550 8'4"
Dump clearance at full lift and 45° discharge (°)	mm ft/in	3335 10'11"	3267 10'9"	3231 10'7"	3162 10'4"	3231 10'7"	3162 10'4"	3130 10'3"
Reach at full tilt and 45° discharge (°)	mm ft/in	992 3'3"	1060 3'6"	1095 3'7"	1164 3'10"	1095 3'7"	1164 3'10"	1199 3'11"
Reach at 45° discharge and 2130 mm (7'0") clearance (°)	mm ft/in	1947 6'5"	1985 6'6"	2003 6'7"	2038 6'8"	2003 6'7"	2038 6'8"	2056 6'9"
Reach with lift arms horizontal and bucket level	mm ft/in	2686 8'10"	2783 9'2"	2832 9'3"	2930 9'7"	2832 9'3"	2930 9'7"	2976 9'9"
Digging depth (°)	mm in	74 2.9	82 3.2	87 3.4	95 3.7	87 3.4	95 3.7	99 3.9
Overall length	mm ft/in	7649 25'1"	7752 25'5"	7795 25'7"	7899 25'11"	7777 25'6"	7881 25'10"	7957 26'1"
Overall height with bucket at full raise (°)	mm ft/in	5574 18'3"	5702 18'8"	5574 18'3"	5702 18'8"	5574 18'3"	5702 18'8"	5833 19'2"
Loader clearance radius with bucket in carry position (°)	mm ft/in	5828 18'3"	5861 18'3"	5910 18'3"	5944 18'3"	5910 18'3"	5944 18'3"	5931 18'3"
Static tipping load straight (°)	kg lb	6789 14,968	6621 14,596	6634 14,625	6463 14,248	6732 14,843	6563 14,469	6500 14,331
Static tipping load with 40° turn (°)	kg lb	5916 13,042	5751 12,679	5760 12,699	5593 12,330	5859 12,917	5693 12,551	5642 12,439
Breakout force (°)	kg lb	9857 21,731	9003 19,848	9736 21,464	8882 19,582	10 432 22,999	9475 20,889	7733 17,048
Operating weight	kg lb	11 620 25,618	11 754 25,913	11 755 25,915	11 889 26,211	11 669 25,726	11 803 26,021	11 782 25,975

NOTE: Specifications and ratings conform to all applicable standards recommended by the Society of Automotive Engineers (SAE). SAE Standards J732 JUN92 and J742 FEB85 govern loader rating, denoted in the text by (°).

	Change in Operating Weight		Change in Articulated Static Tipping Load	
	kg	lb	kg	lb
Without Air conditioner	- 32	- 70	- 27	- 60
Canopy, ROPS (less cab)	- 199	- 439	- 166	- 366
Counterweight, 175 kg (385 lb) (removal)	- 175	- 386	- 273	- 602
Without Guard, crankcase	- 15	- 33	- 19	- 42
Without Guard, driveshaft	- 17	- 37	- 5	- 12
Without Guard, power train	- 52	- 114	- 47	- 104
Without Ride Control System	- 40	- 88	- 27	- 60
Without Secondary steering	- 37	- 81	- 31	- 69
<b>Tires, 1-piece rims</b>				
17.5-25, 12PR (L-2)	- 652	- 1437	- 371	- 818
17.5-25, 12PR (L-3)	- 580	- 1279	- 330	- 728
17.5-25, Radial (L-2)	- 612	- 1349	- 348	- 768
17.5-25, Radial (L-3)	- 512	- 1129	- 292	- 644
<b>Tires, 3-piece rims</b>				
17.5-25, 12PR (L-2)	- 528	- 1164	- 301	- 664
17.5-25, 12PR (L-3)	- 456	- 1005	- 260	- 574
17.5-25, Radial (L-2)	- 488	- 1076	- 278	- 613
17.5-25, Radial (L-3)	- 388	- 855	- 221	- 488
550/65 R25, Radial (L-2)	- 196	- 432	- 112	- 247
550/65 R25, Radial (L-3)	- 136	- 300	- 78	- 172
20.5-25, 12PR (L-2)	- 240	- 529	- 137	- 303
20.5-25, 12PR (L-3)	- 36	- 79	- 21	- 47
20.5 R25, Radial (L-2)	- 172	- 379	- 98	- 217
20.5 R25, Radial (L-3)	0	0	0	0

# Wheel Loaders Integrated Toolcarriers

## Performance Data

- 924H Standard VersaLink Hook On
- Pallet Forks ● Material Handling Arm

		Pallet Forks	
Fork tine length	<b>mm</b> <b>ft/in</b>	1220 <b>4'0"</b>	1370 <b>4'6"</b>
Ground to top of tine clearance	<b>mm</b> <b>ft/in</b>	3637 <b>11'11"</b>	3652 <b>13'0"</b>
Reach with lift arms horizontal and forks level	<b>mm</b> <b>ft/in</b>	1562 <b>5'1"</b>	1577 <b>5'2"</b>
Overall length	<b>mm</b> <b>ft/in</b>	7604 <b>24'11"</b>	7772 <b>25'6"</b>
Static tipping load with level arms and forks, straight*	<b>kg</b> <b>lb</b>	6200 <b>13,640</b>	5962 <b>13,116</b>
Static tipping load with level arms and forks, full 40° turn*	<b>kg</b> <b>lb</b>	5447 <b>11,983</b>	5231 <b>11,508</b>
Operating weight	<b>kg</b> <b>lb</b>	11 209 <b>24,660</b>	11 268 <b>24,790</b>

\*Static tipping load includes lubricants, full fuel tank, ROPS cab and 80 kg (176 lb) operator.  
Machine stability and operating weight are affected by tire size, tire ballast and other attachments.

**NOTE:** The rated operating load for a machine with pallet fork is: SAE J1197 FEB91; 50% of full turn static tipping load, or hydraulic/structural limit. CEN 474-3: 60% of full turn static tipping load on rough terrain: 80% of full turn static tipping load on firm and level ground, or the hydraulic/structural limit.

Handling Arm Position		Material Handling Arm		
		Retracted	Mid-position	Extended
Operating load	<b>kg</b> <b>lb</b>	1974 <b>4343</b>	1569 <b>3452</b>	1304 <b>2869</b>
Static tipping load, straight*	<b>kg</b> <b>lb</b>	4499 <b>9898</b>	3579 <b>7874</b>	2975 <b>6545</b>
Static tipping load, full 40° turn*	<b>kg</b> <b>lb</b>	3949 <b>8688</b>	3139 <b>6906</b>	2607 <b>5735</b>
Operating weight*	<b>kg</b> <b>lb</b>	11 166 <b>24,565</b>	11 166 <b>24,565</b>	11 166 <b>24,565</b>

\*Static tipping load and operating weight include lubricants, full fuel tank, ROPS cab and 80 kg (176 lb) operator.  
Machine stability and operating weight are affected by tire size, tire ballast and other attachments.

**NOTE:** The rated operating load for a machine with material handling arm is 50% of full turn static tipping load, or the hydraulic/structural limit.

- 924H High Lift VersaLink Hook On
- Pallet Forks ● Material Handling Arm

## Wheel Loaders Integrated Toolcarriers

		Pallet Forks	
Fork tine length	mm ft/in	1220 4'0"	1370 4'6"
Ground to top of tine clearance	mm ft/in	4144 13'7"	4155 13'8"
Reach with lift arms horizontal and forks level	mm ft/in	1952 6'5"	1967 6'6"
Overall length	mm ft/in	8113 26'7"	8278 27'2"
Static tipping load with level arms and forks, straight*	kg lb	5322 11,708	5128 11,282
Static tipping load with level arms and forks, full 40° turn*	kg lb	4658 10,248	4481 9858
Operating weight	kg lb	11 327 24,919	11 386 25,049

\*Static tipping load includes lubricants, full fuel tank, ROPS cab and 80 kg (176 lb) operator.  
Machine stability and operating weight are affected by tire size, tire ballast and other attachments.

**NOTE:** The rated operating load for a machine with pallet fork is: SAE J1197 FEB91; 50% of full turn static tipping load, or hydraulic/structural limit. CEN 474-3: 60% of full turn static tipping load on rough terrain; 80% of full turn static tipping load on firm and level ground, or the hydraulic/structural limit.

Handling Arm Position		Material Handling Arm		
		Retracted	Mid-position	Extended
Operating load	kg lb	1745 3839	1412 3106	1187 2611
Static tipping load, straight*	kg lb	3991 8780	3232 7110	2716 5975
Static tipping load, full 40° turn*	kg lb	2489 5476	2823 6211	2373 5221
Operating weight*	kg lb	11 285 24,827	11 285 24,827	11 285 24,827

\*Static tipping load and operating weight include lubricants, full fuel tank, ROPS cab and 80 kg (176 lb) operator.  
Machine stability and operating weight are affected by tire size, tire ballast and other attachments.

**NOTE:** The rated operating load for a machine with material handling arm is 50% of full turn static tipping load, or the hydraulic/structural limit.



Bucket Type		General Purpose						Penetration
		Bolt-on Cutting Edges		Bolt-on Teeth & Segments*		Bolt-on Teeth*		Flush Mounted Teeth*
Ground Engaging Type								
Rated bucket capacity (\$)	m <sup>3</sup>	2.0	2.3	2.0	2.3	1.9	2.2	2.2
	yd <sup>3</sup>	2.6	3.0	2.6	3.0	2.5	2.9	2.9
Struck capacity (\$)	m <sup>3</sup>	1.7	1.9	1.7	1.9	1.6	1.8	1.9
	yd <sup>3</sup>	2.2	2.5	2.2	2.5	2.1	2.4	2.5
Bucket width	mm	2549	2549	2549	2549	2549	2549	2532
	ft/in	8'4"	8'4"	8'4"	8'4"	8'4"	8'4"	8'4"
Dump clearance at full lift and 45° discharge*** (\$)	mm	2879	2842	2766	2729	2766	2729	2719
	ft/in	9'5"	9'4"	9'1"	8'11"	9'1"	8'11"	8'11"
Reach at full lift and 45° discharge (\$)	mm	927	963	1021	1057	1021	1057	1040
	ft/in	3'0"	3'2"	3'4"	3'6"	3'4"	3'6"	3'5"
Reach at 45° discharge and 2130 mm (7'0") clearance (\$)	mm	1455	1474	1492	1509	1492	1509	1486
	ft/in	4'9"	4'10"	4'11"	4'11"	4'11"	4'11"	4'11"
Reach with arms horizontal and bucket level	mm	2253	2305	2399	2451	2399	2451	2451
	ft/in	7'5"	7'7"	7'10"	8'0"	7'10"	8'0"	8'0"
Digging depth (\$)	mm	86	86	99	99	99	99	97
	in	3.4	3.4	3.9	3.9	3.9	3.9	3.8
Overall length	mm	7125	7177	7271	7323	7251	7303	7303
	ft/in	23'5"	23'7"	23'10"	24'0"	23'9"	24'0"	24'0"
Overall height with bucket at full raise (\$)	mm	4984	5075	4984	5075	4984	5075	5075
	ft/in	16'4"	16'8"	16'4"	16'8"	16'4"	16'8"	16'8"
Loader clearance circle with bucket in carry position	mm	5798	5795	5841	5840	5838	5837	5831
	ft/in	19'0"	19'0"	19'2"	19'2"	19'2"	19'2"	19'2"
Static tipping load, straight* (\$)	kg	9983	9911	9819	9746	9923	9851	9951
	lb	22,008	21,850	21,647	21,486	21,876	21,717	21,938
Static tipping load, full 40° turn* (\$)	kg	8654	8585	8490	8420	8594	8525	8615
	lb	19,079	18,928	18,718	18,564	18,948	18,795	18,992
Breakout force** (\$)	kg	9519	9002	9398	8881	10,229	9635	9704
	lb	20,986	19,846	20,719	19,579	22,551	21,242	21,394
Operating weight*	kg	12,564	12,618	12,699	12,753	12,614	12,668	12,667
	lb	27,699	27,818	27,997	28,116	27,809	27,928	27,926

\*Static tipping load and operating weight are based on standard machine configuration with 20.5-25, 12 PR (L-2) tires, full fuel tank, coolant, lubricants, operator and optional counterweight.

\*\*Measured 102 mm (4") behind tip of cutting edge with bucket hinge pin as pivot point in accordance with SAE J732 JUN92.

\*\*\*Dump clearance, reach and overall length dimensions for bucket equipped with teeth reflect actual dimensions. SAE J732 JUN92 allows dimensions for buckets with teeth to reflect the dimension using the cutting edge. Caterpillar Inc. uses actual equipped bucket dimensions.

**NOTE:** Specifications and ratings conform to all applicable standards recommended by the Society of Automotive Engineers (SAE). SAE Standards J732 JUN92 and J742 FEB85 govern loader ratings, denoted in the text by (\$).

	Change in Operating Weight		Change in Articulated Static Tipping Load	
	kg	lb	kg	lb
Air conditioner	+ 48	+ 106	+ 56	+ 123
Canopy, ROPS (less cab)	-198	- 437	-182	- 401
Counterweight, 296 kg (653 lb) (removal)	-174	- 383	-278	- 612
Optional Counterweight, 470 kg (1036 lb) (removal)	-470	-1034	-751	-1652
Crankcase guard	+ 17	+ 37	+ 24	+ 53
Power train guard	+ 58	+ 128	+ 56	+ 123
Ride Control System	+ 41	+ 90	+ 20	+ 44
Secondary steering	+ 42	+ 93	+ 57	+ 126
Tires & 1-piece rims, 17.5-25, 12PR (L-2)	-661	-1454	-410	- 902
Tires & 1-piece rims, 17.5-25, 12PR (L-3)	-582	-1280	-361	- 794
Tires & 1-piece rims, 17.5-25, 12PR (L-2/L-3)	-519	-1142	-322	- 708
Tires & 1-piece rims, 17.5-R25, Radial (L-2)	-614	-1351	-381	- 838
Tires & 1-piece rims, 17.5-R25, Radial (L-3)	-458	-1008	-284	- 625
Tires & 3-piece rims, 17.5-25, 12PR (L-2)	-529	-1164	-328	- 722
Tires & 3-piece rims, 17.5-25, 12PR (L-3)	-457	-1005	-283	- 623
Tires & 3-piece rims, 17.5-25, 12PR (L-2/L-3)	-413	- 909	-256	- 563
Tires & 3-piece rims, 17.5-R25, Radial (L-2)	-489	-1076	-303	- 667
Tires & 3-piece rims, 17.5-R25, Radial (L-3)	-389	- 856	-241	- 530
Tires & 3-piece rims, 20.5-R25, 12PR (L-2)	-240	- 528	-149	- 328
Tires & 3-piece rims, 20.5-25, 12PR (L-3)	- 96	- 211	- 60	- 132
Tires & 3-piece rims, 20.5-25, 12 Radial (L-2/L-3)	- 52	- 114	- 33	- 73
Tires & 3-piece rims, 20.5-R25, Radial (L-2)	-172	- 378	-107	- 235
Tires & 3-piece rims, 20.5-R25, Radial (L-3)	0	0	0	0
Tires & 3-piece rims, 600/65 R25, Radial (L-3) Michelin	+ 4	+ 9	+ 2	+ 4

Bucket Type		General Purpose					
		Bolt-on Cutting Edges		Bolt-on Teeth & Segments		Bolt-on Teeth	
Ground Engaging Type							
Rated bucket capacity	m <sup>3</sup>	2.3	2.5	2.3	2.5	2.1	2.3
	yd <sup>3</sup>	3.0	3.2	3.0	3.2	2.7	3.0
Struck capacity	m <sup>3</sup>	1.9	2.1	1.9	2.1	1.8	2.0
	yd <sup>3</sup>	2.5	2.7	2.5	2.7	2.4	2.6
Bucket width	mm	2550	2550	2620	2620	2620	2620
	ft/in	8'4"	8'4"	8'7"	8'7"	8'7"	8'7"
Dump clearance at full lift and 45° discharge (\$)	mm	2907	2861	2794	2748	2794	2748
	ft/in	9'6"	9'5"	9'2"	9'0"	9'2"	9'0"
Reach at full tilt and 45° discharge (\$)	mm	923	969	1017	1063	1017	1063
	ft/in	3'0"	3'2"	3'4"	3'6"	3'4"	3'6"
Reach at 45° discharge and 2130 mm (7'0") clearance (\$)	mm	1535	1556	1567	1585	1567	1585
	ft/in	5'0"	5'1"	5'2"	5'2"	5'2"	5'2"
Reach with lift arms horizontal and bucket level	mm	2456	2521	2602	2667	2602	2667
	ft/in	8'1"	8'3"	8'6"	8'9"	8'6"	8'9"
Digging depth (\$)	mm	157	157	170	170	170	170
	in	6.2	6.2	6.7	6.7	6.7	6.7
Overall length	mm	7507	7572	7653	7718	7633	7698
	ft/in	24'8"	24'10"	25'1"	25'4"	25'1"	25'3"
Overall height with bucket at full raise (\$)	mm	5288	5354	5288	5354	5288	5354
	ft/in	17'4"	17'7"	17'4"	17'7"	17'4"	17'7"
Loader clearance radius with bucket in carry position (\$)	mm	5781	5798	5856	5873	5856	5873
	ft/in	19'0"	19'0"	19'3"	19'3"	19'3"	19'3"
Static tipping load straight (\$)	kg	9716	9623	9554	9459	9657	9563
	lb	21,421	21,214	21,062	20,853	21,290	21,082
Static tipping load with 40° turn (\$)	kg	8485	8398	8323	8234	8426	8338
	lb	18,707	18,514	18,348	18,153	18,576	18,383
Breakout force (\$)	kg	14 548	13 741	14 414	13 606	15 410	14 502
	lb	32,073	30,294	31,778	29,996	33,973	31,972
Operating weight	kg	12 970	13 011	13 105	13 146	13 019	13 060
	lb	28,594	28,684	28,892	28,982	28,702	28,793

NOTE: Specifications and ratings conform to all applicable standards recommended by the Society of Automotive Engineers (SAE). SAE Standards J732 JUN92 and J742 FEB85 govern loader rating, denoted in the text by (\$).

	Change in Operating Weight		Change in Articulated Static Tipping Load	
	kg	lb	kg	lb
Without air conditioner . . . . .	- 71	- 156	- 76	- 167
Canopy, ROPS (less cab) . . . . .	-218	- 481	-149	- 328
Without Optional Counterweight 470 kg (1036 lb) . . . . .	-470	-1034	-658	-1448
Without Guard, crankcase . . . . .	- 16	- 35	- 20	- 44
Without Guard, driveshaft . . . . .	- 17	- 37	- 12	- 26
Without Guard, power train . . . . .	- 58	- 128	- 49	- 108
Without Ride Control System . . . . .	- 45	- 99	- 24	- 53
Without Secondary steering . . . . .	- 17	- 37	- 20	- 44
<b>Tires, 1-piece rims</b>				
17.5-25, 12PR (L-2) . . . . .	-652	-1434	-365	- 803
17.5-25, 12PR (L-3) . . . . .	-580	-1276	-325	- 715
17.5-25, Radial (L-2) . . . . .	-612	-1346	-343	- 755
17.5-25, Radial (L-3) . . . . .	-512	-1126	-287	- 631
<b>Tires, 3-piece rims</b>				
17.5-25, 12PR (L-2) . . . . .	-528	-1162	-296	- 651
17.5-25, 12PR (L-3) . . . . .	-456	-1003	-255	- 561
17.5-25, Radial (L-2) . . . . .	-488	-1074	-273	- 601
17.5-25, Radial (L-3) . . . . .	-388	- 854	-217	- 477
20.5-25, 12PR (L-2) . . . . .	-240	- 528	-134	- 295
20.5-25, 12PR (L-3) . . . . .	- 36	- 79	- 20	- 44
20.5-25, Radial (L-2) . . . . .	-172	- 378	- 96	- 211
20.5-25, Radial (L-3) . . . . .	0	0	0	0
600/65 R25, Radial (L-3) Michelin . . . . .	+ 4	+ 9	+ 2	+ 4

Bucket Type		High Density General Purpose						Light Material	
		Bolt-on Cutting Edges		Bolt-on Teeth & Segments		Bolt-on Teeth		Bolt-on Cutting Edge	
Rated bucket capacity	m <sup>3</sup>	2.1	2.3	2.1	2.3	2.0	2.1	2.8	
	yd <sup>3</sup>	2.7	3.0	2.7	3.0	2.6	2.7	3.6	
Struck capacity	m <sup>3</sup>	1.7	2.0	1.7	1.8	1.6	1.9	2.3	
	yd <sup>3</sup>	2.2	2.6	2.2	2.4	2.1	2.5	3.0	
Bucket width	mm	2550	2550	2620	2620	2620	2620	2550	
	ft/in	8'4"	8'4"	8'7"	8'7"	8'7"	8'7"	8'4"	
Dump clearance at full lift and 45° discharge (§)	mm	3017	2982	2913	2878	2913	2878	2880	
	ft/in	9'11"	9'9"	9'7"	9'5"	9'7"	9'5"	9'5"	
Reach at full tilt and 45° discharge (§)	mm	966	1005	1070	1108	1070	1108	1103	
	ft/in	3'2"	3'4"	3'6"	3'8"	3'6"	3'8"	3'7"	
Reach at 45° discharge and 2130 mm (7'0") clearance (§)	mm	1633	1654	1685	1705	1685	1705	1701	
	ft/in	5'4"	5'5"	5'6"	5'7"	5'6"	5'7"	5'7"	
Reach with lift arms horizontal and bucket level	mm	2385	2436	2531	2582	2531	2582	2578	
	ft/in	7'10"	8'0"	8'4"	8'6"	8'4"	8'6"	8'5"	
Digging depth (§)	mm	150	157	163	170	163	170	167	
	in	5.9	6.2	6.4	6.7	6.4	6.7	6.6	
Overall length	mm	7430	7487	7576	7633	7556	7613	7637	
	ft/in	24'5"	24'7"	24'10"	25'1"	24'9"	25'0"	25'1"	
Overall height with bucket at full raise (§)	mm	5263	5271	5263	5271	5263	5271	5320	
	ft/in	17'3"	17'4"	17'3"	17'4"	17'3"	17'4"	17'5"	
Loader clearance radius with bucket in carry position (§)	mm	5760	5776	5835	5850	5835	5850	5817	
	ft/in	18'11"	18'11"	19'2"	19'2"	19'2"	19'2"	19'1"	
Static tipping load straight (§)	kg	10 007	9937	9844	9773	9947	9877	9723	
	lb	22,061	21,907	21,702	21,547	21,930	21,776	21,435	
Static tipping load with 40° turn (§)	kg	8755	8693	8593	8530	8696	8634	8490	
	lb	19,302	19,166	18,944	18,805	19,171	19,034	18,718	
Breakout force (§)	kg	15 580	14 865	15 445	14 731	16 575	15 764	13 154	
	lb	34,348	32,772	34,051	32,476	36,542	34,754	29,000	
Operating weight	kg	12 848	12 851	12 983	12 986	12 898	12 900	12 969	
	lb	28,325	28,332	28,623	28,629	28,435	28,440	28,592	

NOTE: Specifications and ratings conform to all applicable standards recommended by the Society of Automotive Engineers (SAE). SAE Standards J732 JUN92 and J742 FEB85 govern loader rating, denoted in the text by (§).

	Change in Operating Weight		Change in Articulated Static Tipping Load	
	kg	lb	kg	lb
Without air conditioner	- 71	- 156	- 76	- 167
Canopy, ROPS (less cab)	-218	- 481	-149	- 328
Without Optional Counterweight 470 kg (1036 lb)	-470	-1034	-658	-1448
Without Guard, crankcase	- 16	- 35	- 20	- 44
Without Guard, driveshaft	- 17	- 37	- 12	- 26
Without Guard, power train	- 58	- 128	- 49	- 108
Without Ride Control System	- 45	- 99	- 24	- 53
Without Secondary steering	- 17	- 37	- 20	- 44
<b>Tires, 1-piece rims</b>				
17.5-25, 12PR (L-2)	-652	-1434	-365	- 803
17.5-25, 12PR (L-3)	-580	-1276	-325	- 715
17.5-25, Radial (L-2)	-612	-1346	-343	- 755
17.5-25, Radial (L-3)	-512	-1126	-287	- 631
<b>Tires, 3-piece rims</b>				
17.5-25, 12PR (L-2)	-528	-1162	-296	- 651
17.5-25, 12PR (L-3)	-456	-1003	-255	- 561
17.5-25, Radial (L-2)	-488	-1074	-273	- 601
17.5-25, Radial (L-3)	-388	- 854	-217	- 477
20.5-25, 12PR (L-2)	-240	- 528	-134	- 295
20.5-25, 12PR (L-3)	- 36	- 79	- 20	- 44
20.5-25, Radial (L-2)	-172	- 378	- 96	- 211
20.5-25, Radial (L-3)	0	0	0	0
600/65 R25, Radial (L-3) Michelin	+ 4	+ 9	+ 2	+ 4

Bucket Type	General Purpose						
	Ground Engaging Type	Bolt-on Cutting Edges		Bolt-on Teeth & Segments		Bolt-on Teeth	
Rated bucket capacity	m <sup>3</sup> yd <sup>3</sup>	2.3 3.0	2.5 3.2	2.3 3.0	2.5 3.2	2.1 2.7	2.3 3.0
Struck capacity	m <sup>3</sup> yd <sup>3</sup>	1.9 2.5	2.1 2.7	1.9 2.5	2.1 2.7	1.8 2.4	2.0 2.6
Bucket width	mm ft/in	2550 8'4"	2550 8'4"	2620 8'7"	2620 8'7"	2620 8'7"	2620 8'7"
Dump clearance at full lift and 45° discharge (°)	mm ft/in	3407 11'2"	3361 11'0"	3294 10'10"	3248 10'8"	3294 10'10"	3248 10'8"
Reach at full tilt and 45° discharge (°)	mm ft/in	923 3'0"	969 3'2"	1017 3'4"	1063 3'6"	1017 3'4"	1063 3'6"
Reach at 45° discharge and 2130 mm (7'0") clearance (°)	mm ft/in	1972 6'6"	1997 6'7"	2013 6'7"	2036 6'8"	2013 6'7"	2036 6'8"
Reach with lift arms horizontal and bucket level	mm ft/in	2850 9'4"	2915 9'7"	2996 9'10"	3061 10'1"	2996 9'10"	3061 10'1"
Digging depth (°)	mm in	172 6.8	172 6.8	185 7.3	185 7.3	185 7.3	185 7.3
Overall length	mm ft/in	7992 26'3"	8057 26'5"	8138 26'8"	8203 26'11"	8121 26'8"	8186 26'10"
Overall height with bucket at full raise (°)	mm ft/in	5788 19'0"	5854 19'2"	5788 19'0"	5854 19'2"	5788 19'0"	5854 19'2"
Loader clearance radius with bucket in carry position (°)	mm ft/in	6034 19'10"	6054 19'10"	6114 20'1"	6134 20'1"	6114 20'1"	6134 20'1"
Static tipping load straight (°)	kg lb	7728 17,038	7644 16,852	7572 16,692	7486 16,504	7671 16,911	7586 16,724
Static tipping load with 40° turn (°)	kg lb	6714 14,803	6635 14,628	6558 14,457	6477 14,280	6657 14,676	6577 14,501
Breakout force (°)	kg lb	14 548 32,073	13 741 30,294	14 414 31,778	13 606 29,996	15 410 33,973	14 502 31,972
Operating weight	kg lb	13 117 28,918	13 158 29,009	13 253 29,218	13 294 29,308	13 167 29,028	13 208 29,119

NOTE: Specifications and ratings conform to all applicable standards recommended by the Society of Automotive Engineers (SAE). SAE Standards J732 JUN92 and J742 FEB85 govern loader rating, denoted in the text by (°).

	Change in Operating Weight		Change in Articulated Static Tipping Load	
	kg	lb	kg	lb
Without air conditioner	- 71	- 156	- 76	- 167
Canopy, ROPS (less cab)	-218	- 481	-149	- 328
Without Optional Counterweight 470 kg (1036 lb)	-470	-1034	-658	-1448
Without Guard, crankcase	- 16	- 35	- 20	- 44
Without Guard, driveshaft	- 17	- 37	- 12	- 26
Without Guard, power train	- 58	- 128	- 49	- 108
Without Ride Control System	- 45	- 99	- 24	- 53
Without Secondary steering	- 17	- 37	- 20	- 44
<b>Tires, 1-piece rims</b>				
17.5-25, 12PR (L-2)	-652	-1434	-365	- 803
17.5-25, 12PR (L-3)	-580	-1276	-325	- 715
17.5-25, Radial (L-2)	-612	-1346	-343	- 755
17.5-25, Radial (L-3)	-512	-1126	-287	- 631
<b>Tires, 3-piece rims</b>				
17.5-25, 12PR (L-2)	-528	-1162	-296	- 651
17.5-25, 12PR (L-3)	-456	-1003	-255	- 561
17.5-25, Radial (L-2)	-488	-1074	-273	- 601
17.5-25, Radial (L-3)	-388	- 854	-217	- 477
20.5-25, 12PR (L-2)	-240	- 528	-134	- 295
20.5-25, 12PR (L-3)	- 36	- 79	- 20	- 44
20.5-25, Radial (L-2)	-172	- 378	- 96	- 211
20.5-25, Radial (L-3)	0	0	0	0
600/65 R25, Radial (L-3) Michelin	+ 4	+ 9	+ 2	+ 4

Bucket Type		High Density General Purpose						Light Material	
		Bolt-on Cutting Edges		Bolt-on Teeth & Segments		Bolt-on Teeth		Bolt-on Cutting Edge	
Rated bucket capacity	m <sup>3</sup>	2.1	2.3	2.1	2.3	2.0	2.1	2.8	
	yd <sup>3</sup>	2.7	3.0	2.7	3.0	2.6	2.7	3.6	
Struck capacity	m <sup>3</sup>	1.7	2.0	1.7	1.8	1.6	1.9	2.3	
	yd <sup>3</sup>	2.2	2.6	2.2	2.4	2.1	2.5	3.0	
Bucket width	mm	2550	2550	2620	2620	2620	2620	2550	
	ft/in	8'4"	8'4"	8'7"	8'7"	8'7"	8'7"	8'4"	
Dump clearance at full lift and 45° discharge (°)	mm	3517	3482	3413	3378	3413	3378	3380	
	ft/in	11'6"	11'5"	11'2"	11'1"	11'2"	11'1"	11'1"	
Reach at full tilt and 45° discharge (°)	mm	966	1004	1069	1108	1069	1108	1103	
	ft/in	3'2"	3'4"	3'6"	3'8"	3'6"	3'8"	3'7"	
Reach at 45° discharge and 2130 mm (7'0") clearance (°)	mm	2062	2086	2121	2144	2121	2144	2140	
	ft/in	6'9"	6'10"	7'0"	7'0"	7'0"	7'0"	7'0"	
Reach with lift arms horizontal and bucket level	mm	2779	2830	2925	2976	2925	2976	2972	
	ft/in	9'1"	9'3"	9'7"	9'9"	9'7"	9'9"	9'9"	
Digging depth (°)	mm	165	172	178	185	178	185	182	
	in	6.5	6.8	7.0	7.3	7.0	7.3	7.2	
Overall length	mm	7916	7972	8062	8118	8046	8101	8120	
	ft/in	26'0"	26'2"	26'5"	26'8"	26'5"	26'7"	26'8"	
Overall height with bucket at full raise (°)	mm	5763	5771	5763	5771	5763	5771	5820	
	ft/in	18'11"	18'11"	18'11"	18'11"	18'11"	18'11"	19'1"	
Loader clearance radius with bucket in carry position (°)	mm	6011	6028	6090	6108	6090	6108	6075	
	ft/in	19'9"	19'9"	20'0"	20'0"	20'0"	20'0"	19'11"	
Static tipping load straight (°)	kg	7973	7917	7817	7760	7916	7859	7712	
	lb	17,578	17,454	17,233	17,107	17,452	17,327	17,003	
Static tipping load with 40° turn (°)	kg	6944	6894	6787	6736	6887	6836	6700	
	lb	15,309	15,199	14,964	14,851	15,183	15,071	14,771	
Breakout force (°)	kg	15 580	14 865	15 445	14 731	16 575	15 764	13 154	
	lb	34,348	32,772	34,051	32,476	36,542	34,754	29,000	
Operating weight	kg	12 996	12 998	13 131	13 134	13 045	13 048	13 116	
	lb	28,651	28,656	28,949	28,956	28,759	28,766	28,916	

**NOTE:** Specifications and ratings conform to all applicable standards recommended by the Society of Automotive Engineers (SAE). SAE Standards J732 JUN92 and J742 FEB85 govern loader rating, denoted in the text by (°).

	Change in Operating Weight		Change in Articulated Static Tipping Load	
	kg	lb	kg	lb
Without air conditioner	- 71	- 156	- 76	- 167
Canopy, ROPS (less cab)	-218	- 481	-149	- 328
Without Optional Counterweight 470 kg (1036 lb)	-470	-1034	-658	-1448
Without Guard, crankcase	- 16	- 35	- 20	- 44
Without Guard, driveshaft	- 17	- 37	- 12	- 26
Without Guard, power train	- 58	- 128	- 49	- 108
Without Ride Control System	- 45	- 99	- 24	- 53
Without Secondary steering	- 17	- 37	- 20	- 44
<b>Tires, 1-piece rims</b>				
17.5-25, 12PR (L-2)	-652	-1434	-365	- 803
17.5-25, 12PR (L-3)	-580	-1276	-325	- 715
17.5-25, Radial (L-2)	-612	-1346	-343	- 755
17.5-25, Radial (L-3)	-512	-1126	-287	- 631
<b>Tires, 3-piece rims</b>				
17.5-25, 12PR (L-2)	-528	-1162	-296	- 651
17.5-25, 12PR (L-3)	-456	-1003	-255	- 561
17.5-25, Radial (L-2)	-488	-1074	-273	- 601
17.5-25, Radial (L-3)	-388	- 854	-217	- 477
20.5-25, 12PR (L-2)	-240	- 528	-134	- 295
20.5-25, 12PR (L-3)	- 36	- 79	- 20	- 44
20.5-25, Radial (L-2)	-172	- 378	- 96	- 211
20.5-25, Radial (L-3)	0	0	0	0
600/65 R25, Radial (L-3) Michelin	+ 4	+ 9	+ 2	+ 4

Performance Data  
 ● 930H Standard VersaLink Hook On  
 Using Quick Coupler

Wheel Loaders  
 Integrated Toolcarriers

Bucket Type	General Purpose									
	Ground Engaging Type	Bolt-on Cutting Edges			Bolt-on Teeth & Segments			Bolt-on Teeth		
Rated bucket capacity	m <sup>3</sup> yd <sup>3</sup>	2.1 2.7	2.3 3.0	2.5 3.2	2.1 2.7	2.3 3.0	2.5 3.2	1.9 2.4	2.1 2.7	2.3 3.0
Struck capacity	m <sup>3</sup> yd <sup>3</sup>	1.7 2.2	1.9 2.5	2.1 2.7	1.7 2.2	1.9 2.5	2.1 2.7	1.6 2.1	1.8 2.4	2.0 2.6
Bucket width	mm ft/in	2550 8'4"	2550 8'4"	2550 8'4"	2620 8'7"	2620 8'7"	2620 8'7"	2620 8'7"	2620 8'7"	2620 8'7"
Dump clearance at full lift and 45° discharge (§)	mm ft/in	2833 9'4"	2773 9'1"	2727 8'11"	2721 8'11"	2660 8'9"	2614 8'7"	2721 8'11"	2660 8'9"	2614 8'7"
Reach at full tilt and 45° discharge (§)	mm ft/in	934 3'1"	995 3'3"	1040 3'5"	1028 3'4"	1089 3'7"	1135 3'9"	1028 3'4"	1089 3'7"	1135 3'9"
Reach at 45° discharge and 2130 mm (7'0") clearance (§)	mm ft/in	1506 4'11"	1531 5'0"	1549 5'1"	1533 5'0"	1554 5'1"	1569 5'2"	1533 5'0"	1554 5'1"	1569 5'2"
Reach with lift arms horizontal and bucket level	mm ft/in	2516 8'3"	2601 8'6"	2666 8'9"	2662 8'9"	2747 9'0"	2812 9'3"	2662 8'9"	2747 9'0"	2812 9'3"
Digging depth (§)	mm in	201 7.9	201 7.9	201 7.9	214 8.4	214 8.4	214 8.4	214 8.4	214 8.4	214 8.4
Overall length	mm ft/in	7601 24'11"	7686 25'3"	7751 25'5"	7747 25'5"	7832 25'8"	7897 25'11"	7728 25'4"	7813 25'8"	7878 25'10"
Overall height with bucket at full raise (§)	mm ft/in	5303 17'5"	5383 17'8"	5470 17'11"	5303 17'5"	5383 17'8"	5470 17'11"	5303 17'5"	5383 17'8"	5470 17'11"
Loader clearance radius with bucket in carry position (§)	mm ft/in	5826 19'1"	5848 19'2"	5865 19'3"	5900 19'4"	5923 19'5"	5940 19'6"	5900 19'4"	5923 19'5"	5940 19'6"
Static tipping load straight (§)	kg lb	9158 20,190	9042 19,933	8951 19,733	8999 19,839	8881 19,579	8789 19,376	9100 20,062	8983 19,804	8891 19,602
Static tipping load with 40° turn (§)	kg lb	7980 17,593	7871 17,352	7785 17,164	7821 17,242	7710 16,998	7623 16,807	7922 17,465	7812 17,223	7726 17,033
Breakout force (§)	kg lb	13,804 30,433	12,852 28,334	12,199 26,894	13,670 30,137	12,717 28,036	12,064 26,597	14,576 32,135	13,512 29,789	12,789 28,195
Operating weight	kg lb	13,114 28,912	13,174 29,044	13,221 29,147	13,250 29,211	13,310 29,344	13,356 29,445	13,164 29,022	13,224 29,154	13,271 29,258

NOTE: Specifications and ratings conform to all applicable standards recommended by the Society of Automotive Engineers (SAE). SAE Standards J732 JUN92 and J742 FEB85 govern loader rating, denoted in the text by (§).

	Change in Operating Weight		Change in Articulated Static Tipping Load	
	kg	lb	kg	lb
Without air conditioner	- 71	- 156	- 76	- 167
Canopy, ROPS (less cab)	- 218	- 481	- 149	- 328
Without Optional Counterweight 470 kg (1036 lb)	- 470	- 1034	- 658	- 1448
Without Guard, crankcase	- 16	- 35	- 20	- 44
Without Guard, driveshaft	- 17	- 37	- 12	- 26
Without Guard, power train	- 58	- 128	- 49	- 108
Without Ride Control System	- 45	- 99	- 24	- 53
Without Secondary steering	- 17	- 37	- 20	- 44
<b>Tires, 1-piece rims</b>				
17.5-25, 12PR (L-2)	- 652	- 1434	- 365	- 803
17.5-25, 12PR (L-3)	- 580	- 1276	- 325	- 715
17.5-25, Radial (L-2)	- 612	- 1346	- 343	- 755
17.5-25, Radial (L-3)	- 512	- 1126	- 287	- 631
<b>Tires, 3-piece rims</b>				
17.5-25, 12PR (L-2)	- 528	- 1162	- 296	- 651
17.5-25, 12PR (L-3)	- 456	- 1003	- 255	- 561
17.5-25, Radial (L-2)	- 488	- 1074	- 273	- 601
17.5-25, Radial (L-3)	- 388	- 854	- 217	- 477
20.5-25, 12PR (L-2)	- 240	- 528	- 134	- 295
20.5-25, 12PR (L-3)	- 36	- 79	- 20	- 44
20.5-25, Radial (L-2)	- 172	- 378	- 96	- 211
20.5-25, Radial (L-3)	0	0	0	0
600/65 R25, Radial (L-3) Michelin	+ 4	+ 9	+ 2	+ 4

# Wheel Loaders Integrated Toolcarriers

## Performance Data ● 930H Standard VersaLink Hook On Using Quick Coupler

Bucket Type	High Density General Purpose							Light Material	
	Ground Engaging Type	Bolt-on Cutting Edges		Bolt-on Teeth & Segments		Bolt-on Teeth		Bolt-on Cutting Edge	
Rated bucket capacity	m <sup>3</sup> yd <sup>3</sup>	2.1 2.7	2.3 3.0	2.1 2.7	2.3 3.0	2.0 2.6	2.1 2.7	2.8 3.6	3.1 4.1
Struck capacity	m <sup>3</sup> yd <sup>3</sup>	1.7 2.2	1.9 2.5	1.7 2.2	1.9 2.5	1.6 2.1	1.8 2.4	2.3 3.0	2.6 3.4
Bucket width	mm ft/in	2550 8'4"	2550 8'4"	2620 8'7"	2620 8'7"	2620 8'7"	2620 8'7"	2550 8'4"	2550 8'4"
Dump clearance at full lift and 45° discharge (°)	mm ft/in	2927 9'7"	2892 9'6"	2822 9'3"	2788 9'2"	2822 9'3"	2788 9'2"	2790 9'2"	2746 9'0"
Reach at full tilt and 45° discharge (°)	mm ft/in	1070 3'6"	1112 3'8"	1174 3'10"	1216 4'0"	1174 3'10"	1216 4'0"	1208 4'0"	1250 4'1"
Reach at 45° discharge and 2130 mm (7'0") clearance (°)	mm ft/in	1693 5'7"	1716 5'8"	1740 5'9"	1761 5'9"	1740 5'9"	1761 5'9"	1755 5'9"	1770 5'10"
Reach with lift arms horizontal and bucket level	mm ft/in	2523 8'3"	2576 8'5"	2670 8'9"	2722 8'11"	2670 8'9"	2722 8'11"	2716 8'11"	2776 9'1"
Digging depth (°)	mm in	152 6.0	157 6.2	165 6.5	170 6.7	165 6.5	170 6.7	169 6.7	176 6.9
Overall length	mm ft/in	7570 24'10"	7627 25'0"	7717 25'4"	7773 25'6"	7696 25'3"	7753 25'5"	7777 25'6"	7842 25'9"
Overall height with bucket at full raise (°)	mm ft/in	5362 17'7"	5375 17'8"	5362 17'7"	5375 17'8"	5362 17'7"	5375 17'8"	5495 18'0"	5552 18'3"
Loader clearance radius with bucket in carry position (°)	mm ft/in	5811 19'1"	5826 19'1"	5885 19'4"	5900 19'4"	5885 19'4"	5900 19'4"	5867 19'3"	5886 19'4"
Static tipping load straight (°)	kg lb	9520 20,988	9415 20,757	9358 20,632	9253 20,398	9461 20,858	9356 20,626	9274 20,446	9209 20,302
Static tipping load with 40° turn (°)	kg lb	8310 18,321	8212 18,104	8149 17,965	8049 17,746	8251 18,191	8152 17,973	8081 17,817	8018 17,676
Breakout force (°)	kg lb	13 727 30,263	13 128 28,942	13 593 29,968	12 994 28,647	14 485 31,934	13 817 30,461	11 792 25,997	11 270 24,846
Operating weight	kg lb	13 016 28,696	13 073 28,821	13 151 28,993	13 208 29,119	13 066 28,806	13 123 28,931	13 120 28,925	13 171 29,037

NOTE: Specifications and ratings conform to all applicable standards recommended by the Society of Automotive Engineers (SAE). SAE Standards J732 JUN92 and J742 FEB85 govern loader rating, denoted in the text by (°).

	Change in Operating Weight		Change in Articulated Static Tipping Load	
	kg	lb	kg	lb
Without air conditioner	- 71	- 156	- 76	- 167
Canopy, ROPS (less cab)	- 218	- 481	- 149	- 328
Without Optional Counterweight 470 kg (1036 lb)	- 470	- 1034	- 658	- 1448
Without Guard, crankcase	- 16	- 35	- 20	- 44
Without Guard, driveshaft	- 17	- 37	- 12	- 26
Without Guard, power train	- 58	- 128	- 49	- 108
Without Ride Control System	- 45	- 99	- 24	- 53
Without Secondary steering	- 17	- 37	- 20	- 44
<b>Tires, 1-piece rims</b>				
17.5-25, 12PR (L-2)	- 652	- 1434	- 365	- 803
17.5-25, 12PR (L-3)	- 580	- 1276	- 325	- 715
17.5-25, Radial (L-2)	- 612	- 1346	- 343	- 755
17.5-25, Radial (L-3)	- 512	- 1126	- 287	- 631
<b>Tires, 3-piece rims</b>				
17.5-25, 12PR (L-2)	- 528	- 1162	- 296	- 651
17.5-25, 12PR (L-3)	- 456	- 1003	- 255	- 561
17.5-25, Radial (L-2)	- 488	- 1074	- 273	- 601
17.5-25, Radial (L-3)	- 388	- 854	- 217	- 477
20.5-25, 12PR (L-2)	- 240	- 528	- 134	- 295
20.5-25, 12PR (L-3)	- 36	- 79	- 20	- 44
20.5-25, Radial (L-2)	- 172	- 378	- 96	- 211
20.5-25, Radial (L-3)	0	0	0	0
600/65 R25, Radial (L-3) Michelin	+ 4	+ 9	+ 2	+ 4

Performance Data  
 ● 930H High Lift VersaLink Hook On  
 Using Quick Coupler

Wheel Loaders  
 Integrated Toolcarriers

Bucket Type	General Purpose									
	Ground Engaging Type	Bolt-on Cutting Edges			Bolt-on Teeth & Segments			Bolt-on Teeth		
Rated bucket capacity	m <sup>3</sup> yd <sup>3</sup>	2.1 2.7	2.3 3.0	2.5 3.2	2.1 2.7	2.3 3.0	2.5 3.2	1.9 2.4	2.1 2.7	2.3 3.0
Struck capacity	m <sup>3</sup> yd <sup>3</sup>	1.7 2.2	1.9 2.5	2.1 2.7	1.7 2.2	1.9 2.5	2.1 2.7	1.6 2.1	1.8 2.4	2.0 2.6
Bucket width	mm ft/in	2550 8'4"	2550 8'4"	2550 8'4"	2620 8'7"	2620 8'7"	2620 8'7"	2620 8'7"	2620 8'7"	2620 8'7"
Dump clearance at full lift and 45° discharge (°)	mm ft/in	3333 10'11"	3273 10'9"	3227 10'7"	3221 10'7"	3160 10'4"	3115 10'3"	3221 10'7"	3160 10'4"	3115 10'3"
Reach at full tilt and 45° discharge (°)	mm ft/in	934 3'1"	994 3'3"	1040 3'5"	1028 3'4"	1088 3'7"	1134 3'9"	1028 3'4"	1088 3'7"	1134 3'9"
Reach at 45° discharge and 2130 mm (7'0") clearance (°)	mm ft/in	1949 6'5"	1980 6'6"	2003 6'7"	1987 6'6"	2015 6'7"	2035 6'8"	1987 6'6"	2015 6'7"	2035 6'8"
Reach with lift arms horizontal and bucket level	mm ft/in	2910 9'7"	2995 9'10"	3060 10'0"	3056 10'0"	3141 10'4"	3206 10'6"	3056 10'0"	3141 10'4"	3206 10'6"
Digging depth (°)	mm in	216 8.5	216 8.5	216 8.5	229 9.0	229 9.0	229 9.0	229 9.0	229 9.0	229 9.0
Overall length	mm ft/in	8080 26'6"	8165 26'9"	8230 27'0"	8226 27'0"	8311 27'3"	8376 27'6"	8210 26'11"	8295 27'3"	8360 27'5"
Overall height with bucket at full raise (°)	mm ft/in	5803 19'0"	5883 19'4"	5970 19'7"	5803 19'0"	5883 19'4"	5970 19'7"	5803 19'0"	5883 19'4"	5970 19'7"
Loader clearance radius with bucket in carry position (°)	mm ft/in	6080 19'11"	6105 20'0"	6124 20'1"	6159 20'2"	6184 20'3"	6204 20'4"	6159 20'2"	6184 20'3"	6204 20'4"
Static tipping load straight (°)	kg lb	7300 16,094	7190 15,852	7107 15,668	7146 15,754	7035 15,509	6950 15,323	7244 15,970	7133 15,727	7050 15,542
Static tipping load with 40° turn (°)	kg lb	6324 13,943	6221 13,715	6142 13,542	6170 13,603	6066 13,373	5986 13,197	6268 13,818	6164 13,590	6085 13,415
Breakout force (°)	kg lb	13,804 30,433	12,852 28,334	12,199 26,894	13,670 30,137	12,717 28,036	12,064 26,597	14,576 32,135	13,512 29,789	12,789 28,195
Operating weight	kg lb	13,262 29,238	13,322 29,370	13,369 29,474	13,398 29,538	13,458 29,670	13,504 29,771	13,312 29,348	13,372 29,480	13,418 29,582

NOTE: Specifications and ratings conform to all applicable standards recommended by the Society of Automotive Engineers (SAE). SAE Standards J732 JUN92 and J742 FEB85 govern loader rating, denoted in the text by (°).

	Change in Operating Weight		Change in Articulated Static Tipping Load	
	kg	lb	kg	lb
Without air conditioner	- 71	- 156	- 76	- 167
Canopy, ROPS (less cab)	- 218	- 481	- 149	- 328
Without Optional Counterweight 470 kg (1036 lb)	- 470	- 1034	- 658	- 1448
Without Guard, crankcase	- 16	- 35	- 20	- 44
Without Guard, driveshaft	- 17	- 37	- 12	- 26
Without Guard, power train	- 58	- 128	- 49	- 108
Without Ride Control System	- 45	- 99	- 24	- 53
Without Secondary steering	- 17	- 37	- 20	- 44
<b>Tires, 1-piece rims</b>				
17.5-25, 12PR (L-2)	- 652	- 1434	- 365	- 803
17.5-25, 12PR (L-3)	- 580	- 1276	- 325	- 715
17.5-25, Radial (L-2)	- 612	- 1346	- 343	- 755
17.5-25, Radial (L-3)	- 512	- 1126	- 287	- 631
<b>Tires, 3-piece rims</b>				
17.5-25, 12PR (L-2)	- 528	- 1162	- 296	- 651
17.5-25, 12PR (L-3)	- 456	- 1003	- 255	- 561
17.5-25, Radial (L-2)	- 488	- 1074	- 273	- 601
17.5-25, Radial (L-3)	- 388	- 854	- 217	- 477
20.5-25, 12PR (L-2)	- 240	- 528	- 134	- 295
20.5-25, 12PR (L-3)	- 36	- 79	- 20	- 44
20.5-25, Radial (L-2)	- 172	- 378	- 96	- 211
20.5-25, Radial (L-3)	0	0	0	0
600/65 R25, Radial (L-3) Michelin	+ 4	+ 9	+ 2	+ 4



# Wheel Loaders Integrated Toolcarriers

## Performance Data ● 930H High Lift VersaLink Hook On Using Quick Coupler

Bucket Type		High Density General Purpose						Light Material	
		Bolt-on Cutting Edges		Bolt-on Teeth & Segments		Bolt-on Teeth		Bolt-on Cutting Edge	
Rated bucket capacity	m <sup>3</sup>	2.1	2.3	2.1	2.3	2.0	2.1	2.80	3.10
	yd <sup>3</sup>	2.7	3.0	2.7	3.0	2.6	2.7	3.66	4.05
Struck capacity	m <sup>3</sup>	1.7	1.9	1.7	1.9	1.6	1.8	2.30	2.60
	yd <sup>3</sup>	2.2	2.5	2.2	2.5	2.1	2.4	3.01	3.40
Bucket width	mm	2550	2550	2620	2620	2620	2620	2550	2550
	ft/in	8'4"	8'4"	8'7"	8'7"	8'7"	8'7"	8'4"	8'4"
Dump clearance at full lift and 45° discharge (§)	mm	3427	3392	3322	3288	3322	3288	3290	3246
	ft/in	11'3"	11'2"	10'11"	10'9"	10'11"	10'9"	10'10"	10'8"
Reach at full tilt and 45° discharge (§)	mm	1070	1112	1174	1215	1174	1215	1208	1250
	ft/in	3'6"	3'8"	3'10"	4'0"	3'10"	4'0"	4'0"	4'1"
Reach at 45° discharge and 2130 mm (7'0") clearance (§)	mm	2128	2154	2184	2209	2184	2209	2203	2222
	ft/in	7'0"	7'1"	7'2"	7'3"	7'2"	7'3"	7'3"	7'3"
Reach with lift arms horizontal and bucket level	mm	2916	2970	3063	3116	3063	3116	3110	3170
	ft/in	9'7"	9'9"	10'1"	10'3"	10'1"	10'3"	10'2"	10'5"
Digging depth (§)	mm	167	172	180	185	180	185	184	191
	in	6.6	6.8	7.1	7.3	7.1	7.3	7.2	7.5
Overall length	mm	8055	8112	8202	8258	8185	8241	8259	8324
	ft/in	26'5"	26'7"	26'11"	27'1"	26'10"	27'0"	27'1"	27'4"
Overall height with bucket at full raise (§)	mm	5862	5875	5862	5875	5862	5875	5995	6052
	ft/in	19'3"	19'3"	19'3"	19'3"	19'3"	19'3"	19'8"	19'10"
Loader clearance radius with bucket in carry position (§)	mm	6062	6080	6141	6158	6141	6158	6126	6147
	ft/in	19'11"	19'11"	20'2"	20'2"	20'2"	20'2"	20'1"	20'2"
Static tipping load straight (§)	kg	7566	7470	7410	7314	7508	7413	7338	7261
	lb	16,679	16,470	16,336	16,124	16,553	16,343	16,177	16,009
Static tipping load with 40° turn (§)	kg	6569	6479	6413	6322	6512	6422	6356	6283
	lb	14,482	14,284	14,138	13,939	14,356	14,158	14,014	13,852
Breakout force (§)	kg	13 727	13 128	13 593	12 994	14 485	13 817	11 792	11 270
	lb	30,263	28,942	29,968	28,647	31,934	30,461	25,997	24,846
Operating weight	kg	13 164	13 221	13 299	13 356	13 214	13 270	13 268	13 319
	lb	29,022	29,147	29,319	29,445	29,132	29,255	29,251	29,364

NOTE: Specifications and ratings conform to all applicable standards recommended by the Society of Automotive Engineers (SAE). SAE Standards J732 JUN92 and J742 FEB85 govern loader rating, denoted in the text by (§).

	Change in Operating Weight		Change in Articulated Static Tipping Load	
	kg	lb	kg	lb
Without air conditioner	- 71	- 156	- 76	- 167
Canopy, ROPS (less cab)	- 218	- 481	- 149	- 328
Without Optional Counterweight 470 kg (1036 lb)	- 470	- 1034	- 658	- 1448
Without Guard, crankcase	- 16	- 35	- 20	- 44
Without Guard, driveshaft	- 17	- 37	- 12	- 26
Without Guard, power train	- 58	- 128	- 49	- 108
Without Ride Control System	- 45	- 99	- 24	- 53
Without Secondary steering	- 17	- 37	- 20	- 44
<b>Tires, 1-piece rims</b>				
17.5-25, 12PR (L-2)	- 652	- 1434	- 365	- 803
17.5-25, 12PR (L-3)	- 580	- 1276	- 325	- 715
17.5-25, Radial (L-2)	- 612	- 1346	- 343	- 755
17.5-25, Radial (L-3)	- 512	- 1126	- 287	- 631
<b>Tires, 3-piece rims</b>				
17.5-25, 12PR (L-2)	- 528	- 1162	- 296	- 651
17.5-25, 12PR (L-3)	- 456	- 1003	- 255	- 561
17.5-25, Radial (L-2)	- 488	- 1074	- 273	- 601
17.5-25, Radial (L-3)	- 388	- 854	- 217	- 477
20.5-25, 12PR (L-2)	- 240	- 528	- 134	- 295
20.5-25, 12PR (L-3)	- 36	- 79	- 20	- 44
20.5-25, Radial (L-2)	- 172	- 378	- 96	- 211
20.5-25, Radial (L-3)	0	0	0	0
600/65 R25, Radial (L-3) Michelin	+ 4	+ 9	+ 2	+ 4

		Pallet Forks		
Fork tine length	mm ft/in	1220 4'0"	1370 4'6"	1524 5'0"
Ground to top of the tine clearance	mm ft/in	3889 12'9"	3903 12'10"	3889 12'9"
Reach with lift arms horizontal and forks level	mm ft/in	1693 5'7"	1708 5'7"	1693 5'7"
Overall length	mm ft/in	7854 25'9"	8019 26'4"	8158 26'9"
Static tipping load with level arms and forks, straight*	kg lb	7247 15,943	6980 15,356	6817 14,997
Static tipping load with level arms and forks, full 40° turn*	kg lb	6357 13,985	6116 13,455	5970 13,134
Operating weight*	kg lb	12 580 27,676	12 648 27,826	12 670 27,874

\*Static tipping and operating weights shown are for 930H with cab with air conditioning, optional counterweight, limited slip axles, heavy-duty rear brakes, additional guarding, sound suppression, work tool, 80 kg (176 lb) operator and 600/65 R25 GP-3D tires. Tipping load is defined by SAE J732 JUN92.

**NOTE:** The rated operating load for a machine with pallet fork is: SAE J1197 FEB91; 50% of full turn static tipping load, or hydraulic/structural limit. CEN 474-3: 60% of full turn static tipping load on rough terrain; 80% of full turn static tipping load on firm and level ground, or the hydraulic/structural limit.

Standard VersaLink				
Handling Arm Position		Material Handling Arm		
		Retracted	Mid-position	Extended
Operating load	kg lb	2333 5133	1868 4110	1559 3430
Static tipping load, straight*	kg lb	5322 11,708	4266 9385	3562 7836
Static tipping load, full 40° turn*	kg lb	4665 10,263	3737 8221	3119 6862
Operating weight*	kg lb	12 547 27,603	12 547 27,603	12 547 27,603

High Lift VersaLink				
Handling Arm Position		Material Handling Arm		
		Retracted	Mid-position	Extended
Operating load	kg lb	2072 4558	1687 3711	1425 3135
Static tipping load, straight*	kg lb	4743 10,435	3867 8507	3266 7185
Static tipping load, full 40° turn*	kg lb	4143 9115	3375 7425	2850 6270
Operating weight*	kg lb	12 695 27,929	12 695 27,929	12 695 27,929

\*Static Tipping Load and Operating Weight include lubricants, full fuel tank, ROPS cab, and 80 kg (176 lb) operator. Machine stability and operating weight are affected by tire size, tire ballast, and other attachments.

**NOTE:** The rated operating load for a machine with material handling arm is 50% of full turn static tipping load or the hydraulic/structural limit.

Bucket Type	General Purpose — Pin On									High Lift Delta	
	Bolt-on Edges	Teeth & Segments	Teeth	Bolt-on Edges	Teeth & Segments	Teeth	Bolt-on Edges	Teeth & Segments	Teeth		
Edge Type											
Capacity — rated	m <sup>3</sup> yd <sup>3</sup>	2.3 3.0	2.3 3.0	2.1 2.8	2.5 3.3	2.5 3.3	2.3 3.0	2.8 3.7	2.8 3.7	2.7 3.5	— —
Capacity — struck	m <sup>3</sup> yd <sup>3</sup>	2.0 2.6	2.0 2.6	1.9 2.4	2.1 2.8	2.1 2.8	2.0 2.6	2.4 3.2	2.4 3.2	2.3 3.0	— —
Width	mm ft/in	2700 8'10"	2777 9'1"	2777 9'1"	2700 8'10"	2777 9'1"	2777 9'1"	2700 8'10"	2777 9'1"	2777 9'1"	— —
Dump clearance at maximum lift and 45° discharge	mm ft/in	2890 9'5"	2786 9'1"	2786 9'1"	2849 9'4"	2744 9'0"	2744 9'0"	2771 9'1"	2664 8'8"	2664 8'8"	+423 +1'5"
Reach at maximum lift and 45° discharge	mm ft/in	993 3'3"	1098 3'7"	1098 3'7"	1019 3'4"	1123 3'8"	1123 3'8"	1077 3'6"	1179 3'10"	1179 3'10"	+112 4.4"
Reach at level lift arm and bucket level	mm ft/in	2189 7'2"	2336 7'7"	2336 7'7"	2239 7'4"	2386 7'9"	2386 7'9"	2339 7'8"	2486 8'1"	2486 8'1"	+381 +1'3"
Digging depth	mm in	50 1.9	50 1.9	25 0.9	50 1.9	50 1.9	25 0.9	50 1.9	50 1.9	25 0.9	+58 +2.3
Overall length	mm ft/in	7173 23'6"	7331 24'0"	7331 24'0"	7223 23'8"	7381 24'2"	7381 24'2"	7323 24'0"	7481 24'6"	7481 24'6"	+490 +1'7"
Overall height with bucket at maximum lift	mm ft/in	5140 16'10"	5140 16'10"	5140 16'10"	5188 17'0"	5188 17'0"	5188 17'0"	5284 17'4"	5284 17'4"	5284 17'4"	+423 +1'5"
Loader clearance circle with bucket at carry position	mm ft/in	11 946 39'2"	12 105 39'8"	12 105 39'8"	11 971 39'3"	12 131 39'9"	12 131 39'9"	12 024 39'5"	12 185 39'11"	12 185 39'11"	+499 +1'8"
Static tipping load — straight*	kg lb	11 784 25,971	11 687 25,757	11 908 26,246	11 706 25,800	11 608 25,584	11 828 26,068	11 544 25,442	11 445 25,224	11 661 25,701	-1999 -4406
Static tipping load — articulated* maximum 40° turn	kg lb	10 260 22,613	10 163 22,399	10 372 22,860	10 187 22,452	10 089 22,236	10 297 22,694	10 034 22,115	9935 21,897	10 140 22,348	-1792 -3949
Breakout force**	kN lb	142 31,876	141 31,701	153 34,295	135 30,316	134 30,141	145 32,506	123 27,574	122 27,401	131 29,393	-5 -1232
Operating weight*	kg lb	14 885 32,808	14 960 32,973	14 865 32,763	14 919 32,881	14 994 33,046	14 899 32,837	14 992 33,043	15 067 33,208	14 972 32,998	+324 +714

\*Static tipping loads and operating weight are based on the following loader configuration: L3 Michelin XHA tires, air conditioning, ride control, power train guard, full fluids, fuel tank, coolant, lubricants and operator.

Static tipping loads conform to the international standard as defined in ISO 14397-1 (SEPT2007).

\*\*Measured 100 mm (4") behind tip of cutting edge with bucket hinge pin as pivot point in accordance with SAE J732 (APR2007).

**NOTE:** Specifications and ratings conform to all applicable standards recommended by the Society of Automotive Engineers, including SAE Standard J732 (APR2007) which governs loader ratings.

	Width over tires maximum (loaded)		Change in vertical dimensions		Change in operating weight without ballast		Change in static tipping load — straight		Change in static tipping load — articulated	
	mm	in	mm	in	kg	lb	kg	lb	kg	lb
20.5-R25 XTLA L2, Radial . . . . .	2603	102	-16	-1	-170	-376	-120	-264	-104	-230
20.5-R25 XHA L3, Radial . . . . .	2674	105	+ 0	+0	+ 0	+ 0	+ 0	+ 0	+ 0	+ 0
20.5 R25 GP2B L3, Radial . . . . .	2619	103	+ 6	+0	- 53	- 116	- 37	- 81	- 32	- 71
20.5 R25 HRL L3, Radial . . . . .	2618	103	+23	+1	- 48	- 107	- 34	- 75	- 30	- 65
20.5 R25 RL-2+ L3, Radial . . . . .	2609	103	+12	+0	+ 13	+ 28	+ 9	+ 20	+ 8	+ 17
650/65R-25 XLD L3, Radial (Low Profile) . . . . .	2733	108	+ 0	+0	+519	+1145	+364	+803	+318	+701
20.5-25 SRG LD L3, Bias (16 ply) . . .	2558	101	+ 8	+0	-242	- 533	-170	-374	-148	-326
20.5-25 SRG LD L3, Bias (20 ply) . . .	2556	101	+11	+0	-174	- 384	-122	-270	-107	-235
20.5-25 RM 99 L3, Bias . . . . .	2540	100	+ 8	+0	- 58	- 129	- 41	- 90	- 36	- 79

\*\*\*Without bulge.

Bucket Type	Edge Type	General Purpose — Pin On			Material Handling — Pin On			High Lift Delta
		Bolt-on Edges	Teeth & Segments	Teeth	Bolt-on Edges	Teeth & Segments	Teeth	
Capacity — rated	m <sup>3</sup>	3.0	3.0	2.9	2.8	2.8	2.7	—
	yd <sup>3</sup>	3.9	3.9	3.7	3.7	3.7	3.5	—
Capacity — struck	m <sup>3</sup>	2.7	2.7	2.6	2.4	2.4	2.3	—
	yd <sup>3</sup>	3.5	3.5	3.3	3.2	3.2	3.0	—
Width	mm	2700	2777	2777	2700	2777	2777	—
	ft/in	8'10"	9'1"	9'1"	8'10"	9'1"	9'1"	—
Dump clearance at maximum lift and 45° discharge	mm	2702	2597	2597	2720	2607	2607	+423
	ft/in	8'10"	8'6"	8'6"	8'11"	8'6"	8'6"	+1'5"
Reach at maximum lift and 45° discharge	mm	1102	1206	1206	1001	1096	1096	+112
	ft/in	3'7"	3'11"	3'11"	3'3"	3'7"	3'7"	+4.4"
Reach at level lift arm and bucket level	mm	2397	2544	2544	2339	2486	2486	+381
	ft/in	7'10"	8'4"	8'4"	7'8"	8'1"	8'1"	+1'3"
Digging depth	mm	110	110	85	50	50	25	+58
	in	4.3	4.3	3.3	1.9	1.9	0.9	+2.3
Overall length	mm	7430	7588	7588	7323	7482	7482	+490
	ft/in	24'4"	24'10"	24'10"	24'0"	24'6"	24'6"	+1'7"
Overall height with bucket at maximum lift	mm	5195	5195	5195	5272	5272	5272	+423
	ft/in	17'0"	17'0"	17'0"	17'3"	17'3"	17'3"	+1'5"
Loader clearance circle with bucket at carry position	mm	12 106	12 267	12 267	12 024	12 185	12 185	+499
	ft/in	39'8"	40'2"	40'2"	39'5"	39'11"	39'11"	+1'8"
Static tipping load — straight*	kg	11 440	11 340	11 553	11 465	11 367	11 577	-1999
	lb	25,213	24,993	25,463	25,268	25,052	25,516	-4406
Static tipping load — articulated* maximum 40° turn	kg	9960	9860	10 062	9966	9868	10 068	-1792
	lb	21,951	21,731	22,177	21,966	21,750	22,190	-3949
Breakout force**	kN	117	116	124	123	122	131	-5
	lb	26,319	26,132	27,958	27,575	27,401	29,393	-1232
Operating weight*	kg	14 831	14 906	14 811	14 981	15 056	14 961	+324
	lb	32,688	32,853	32,644	33,018	33,183	32,974	+714

\*Static tipping loads and operating weight are based on the following loader configuration: L3 Michelin XHA tires, air conditioning, ride control, power train guard, full fluids, fuel tank, coolant, lubricants and operator.

Static tipping loads conform to the international standard as defined in ISO 14397-1 (SEPT2007).

\*\*Measured 100 mm (4") behind tip of cutting edge with bucket hinge pin as pivot point in accordance with SAE J732 (APR2007).

**NOTE:** Specifications and ratings conform to all applicable standards recommended by the Society of Automotive Engineers, including SAE Standard J732 (APR2007) which governs loader ratings.

	Width over tires maximum (loaded)		Change in vertical dimensions		Change in operating weight without ballast		Change in static tipping load — straight		Change in static tipping load — articulated	
	mm	in	mm	in	kg	lb	kg	lb	kg	lb
20.5-R25 XTLA L2, Radial	2603	102	-16	-1	-170	-376	-120	-264	-104	-230
20.5-R25 XHA L3, Radial	2674	105	+ 0	+0	+ 0	+ 0	+ 0	+ 0	+ 0	+ 0
20.5 R25 GP2B L3, Radial	2619	103	+ 6	+0	- 53	- 116	- 37	- 81	- 32	- 71
20.5 R25 HRL L3, Radial	2618	103	+23	+1	- 48	- 107	- 34	- 75	- 30	- 65
20.5 R25 RL-2+ L3, Radial	2609	103	+12	+0	+ 13	+ 28	+ 9	+ 20	+ 8	+ 17
650/65R-25 XLD L3, Radial (Low Profile)	2733	108	+ 0	+0	+519	+1145	+364	+803	+318	+701
20.5-25 SRG LD L3, Bias (16 ply)	2558	101	+ 8	+0	-242	- 533	-170	-374	-148	-326
20.5-25 SRG LD L3, Bias (20 ply)	2556	101	+11	+0	-174	- 384	-122	-270	-107	-235
20.5-25 RM 99 L3, Bias	2540	100	+ 8	+0	- 58	- 129	- 41	- 90	- 36	- 79

\*\*\*Without bulge.

Bucket Type	General Purpose — Fusion QC									High Lift Delta	
	Edge Type	Bolt-on Edges	Teeth & Seg-ments	Teeth	Bolt-on Edges	Teeth & Seg-ments	Teeth	Bolt-on Edges	Teeth & Seg-ments		Teeth
Capacity — rated	m <sup>3</sup> yd <sup>3</sup>	2.3 3.0	2.3 3.0	2.1 2.8	2.5 3.3	2.5 3.3	2.3 3.0	2.9 3.8	2.9 3.8	2.7 3.5	— —
Capacity — struck	m <sup>3</sup> yd <sup>3</sup>	1.7 2.2	1.7 2.2	1.6 2.1	1.8 2.4	1.8 2.4	1.8 2.3	2.2 2.9	2.2 2.9	2.1 2.7	— —
Width	mm ft/in	2700 8'10"	2777 9'1"	2777 9'1"	2700 8'10"	2777 9'1"	2777 9'1"	2700 8'10"	2777 9'1"	2777 9'1"	— —
Dump clearance at maximum lift and 45° discharge	mm ft/in	2816 9'2"	2713 8'10"	2713 8'10"	2765 9'0"	2661 8'8"	2661 8'8"	2669 8'9"	2562 8'4"	2562 8'4"	+423 +1'5"
Reach at maximum lift and 45° discharge	mm ft/in	1038 3'4"	1145 3'9"	1145 3'9"	1068 3'6"	1173 3'10"	1173 3'10"	1135 3'8"	1237 4'0"	1237 4'0"	+112 +4.4"
Reach at level lift arm and bucket level	mm ft/in	2265 7'5"	2412 7'10"	2412 7'10"	2326 7'7"	2473 8'1"	2473 8'1"	2447 8'0"	2594 8'6"	2594 8'6"	+381 +1'3"
Digging depth	mm in	100 3.9	100 3.9	75 2.9	100 3.9	100 3.9	75 2.9	100 3.9	100 3.9	75 2.9	+58 +2.3
Overall length	mm ft/in	7290 23'11"	7448 24'5"	7448 24'5"	7351 24'1"	7509 24'7"	7509 24'7"	7472 24'6"	7630 25'0"	7630 25'0"	+490 +1'7"
Overall height with bucket at maximum lift	mm ft/in	5042 16'6"	5042 16'6"	5042 16'6"	5100 16'8"	5100 16'8"	5100 16'8"	5217 17'1"	5217 17'1"	5217 17'1"	+423 +1'5"
Loader clearance circle with bucket at carry position	mm ft/in	11 977 39'3"	12 132 39'9"	12 132 39'9"	12 007 39'4"	12 162 39'10"	12 162 39'10"	12 067 39'7"	12 224 40'1"	12 224 40'1"	+499 +1'8"
Static tipping load — straight*	kg lb	11 392 25,107	11 295 24,894	11 512 25,372	11 381 25,085	11 284 24,870	11 493 25,331	11 190 24,663	11 091 24,445	11 299 24,903	-1999 -4406
Static tipping load — articulated* maximum 40° turn	kg lb	9851 21,712	9754 21,499	9959 21,949	9846 21,700	9748 21,485	9946 21,920	9665 21,302	9567 21,085	9763 21,518	-1792 -3949
Breakout force**	kN lb	131 29,384	130 29,199	140 31,440	124 27,863	123 27,679	132 29,706	111 25,042	111 24,860	118 26,539	-5 -1232
Operating weight*	kg lb	15 451 34,053	15 526 34,218	15 433 34,013	15 433 34,015	15 508 34,180	15 415 33,975	15 522 34,210	15 597 34,376	15 504 34,171	+324 +714

\*Static tipping loads and operating weight are based on the following loader configuration: L3 Michelin XHA tires, air conditioning, ride control, power train guard, full fluids, fuel tank, coolant, lubricants and operator.

Static tipping loads conform to the international standard as defined in ISO 14397-1 (SEPT2007).

\*\*Measured 100 mm (4") behind tip of cutting edge with bucket hinge pin as pivot point in accordance with SAE J732 (APR2007).

**NOTE:** Specifications and ratings conform to all applicable standards recommended by the Society of Automotive Engineers, including SAE Standard J732 (APR2007) which governs loader ratings.

	Width over tires maximum (loaded)		Change in vertical dimensions		Change in operating weight without ballast		Change in static tipping load — straight		Change in static tipping load — articulated	
	mm	in	mm	in	kg	lb	kg	lb	kg	lb
20.5-R25 XTLA L2, Radial . . . . .	2603	102	-16	-1	-170	-376	-120	-264	-104	-230
20.5-R25 XHA L3, Radial . . . . .	2674	105	+ 0	+0	+ 0	+ 0	+ 0	+ 0	+ 0	+ 0
20.5 R25 GP2B L3, Radial . . . . .	2619	103	+ 6	+0	- 53	- 116	- 37	- 81	- 32	- 71
20.5 R25 HRL L3, Radial . . . . .	2618	103	+23	+1	- 48	- 107	- 34	- 75	- 30	- 65
20.5 R25 RL-2+ L3, Radial . . . . .	2609	103	+12	+0	+ 13	+ 28	+ 9	+ 20	+ 8	+ 17
650/65R-25 XLD L3, Radial (Low Profile) . . . . .	2733	108	+ 0	+0	+519	+1145	+364	+803	+318	+701
20.5-25 SRG LD L3, Bias (16 ply) . . .	2558	101	+ 8	+0	-242	- 533	-170	-374	-148	-326
20.5-25 SRG LD L3, Bias (20 ply) . . .	2556	101	+11	+0	-174	- 384	-122	-270	-107	-235
20.5-25 RM 99 L3, Bias . . . . .	2540	100	+ 8	+0	- 58	- 129	- 41	- 90	- 36	- 79

\*\*\*Without bulge.

Bucket Type	Edge Type	General Purpose — Fusion QC			Material Handling — Fusion QC			High Lift Delta
		Bolt-on Edges	Teeth & Segments	Teeth	Bolt-on Edges	Teeth & Segments	Teeth	
Capacity — rated	m <sup>3</sup>	3.1	3.1	2.9	3.1	3.1	2.9	—
	yd <sup>3</sup>	4.1	4.1	3.8	4.1	4.1	3.8	—
Capacity — struck	m <sup>3</sup>	2.4	2.4	2.3	2.4	2.4	2.3	—
	yd <sup>3</sup>	3.1	3.1	3.0	3.2	3.2	3.1	—
Width	mm	2700	2777	2777	2700	2777	2777	—
	ft/in	8'10"	9'1"	9'1"	8'10"	9'1"	9'1"	—
Dump clearance at maximum lift and 45° discharge	mm	2625	2518	2518	2593	2480	2480	+423
	ft/in	8'7"	8'3"	8'3"	8'6"	8'1"	8'1"	+1'5"
Reach at maximum lift and 45° discharge	mm	1169	1270	1270	1114	1208	1208	+112
	ft/in	3'10"	4'2"	4'2"	3'7"	3'11"	3'11"	+4.4"
Reach at level lift arm and bucket level	mm	2504	2651	2651	2509	2656	2656	+381
	ft/in	8'2"	8'8"	8'8"	8'2"	8'8"	8'8"	+1'3"
Digging depth	mm	100	100	75	60	60	35	+58
	in	3.9	3.9	2.9	2.3	2.3	1.3	+2.3
Overall length	mm	7529	7687	7687	7501	7660	7660	+490
	ft/in	24'8"	25'2"	25'2"	24'7"	25'1"	25'1"	+1'7"
Overall height with bucket at maximum lift	mm	5273	5273	5273	5290	5290	5290	+423
	ft/in	17'3"	17'3"	17'3"	17'4"	17'4"	17'4"	+1'5"
Loader clearance circle with bucket at carry position	mm	12 096	12 253	12 253	12 065	12 223	12 223	+499
	ft/in	39'8"	40'2"	40'2"	39'7"	40'1"	40'1"	+1'8"
Static tipping load — straight*	kg	11 094	10 994	11 200	11 197	11 098	11 304	-1999
	lb	24,450	24,231	24,685	24,678	24,460	24,914	-4406
Static tipping load — articulated* maximum 40° turn	kg	9574	9475	9670	9668	9570	9765	-1792
	lb	21,101	20,882	21,312	21,309	21,091	21,522	-3949
Breakout force**	kN	106	105	112	106	105	112	-5
	lb	23,878	23,696	25,244	23,829	23,656	25,197	-1232
Operating weight*	kg	15 569	15 644	15 551	15 541	15 616	15 523	+324
	lb	34,313	34,478	34,273	34,253	34,418	34,213	+714

\*Static tipping loads and operating weight are based on the following loader configuration: L3 Michelin XHA tires, air conditioning, ride control, power train guard, full fluids, fuel tank, coolant, lubricants and operator.

Static tipping loads conform to the international standard as defined in ISO 14397-1 (SEPT2007).

\*\*Measured 100 mm (4") behind tip of cutting edge with bucket hinge pin as pivot point in accordance with SAE J732 (APR2007).

**NOTE:** Specifications and ratings conform to all applicable standards recommended by the Society of Automotive Engineers, including SAE Standard J732 (APR2007) which governs loader ratings.

	Width over tires maximum (loaded)		Change in vertical dimensions		Change in operating weight without ballast		Change in static tipping load — straight		Change in static tipping load — articulated	
	mm	in	mm	in	kg	lb	kg	lb	kg	lb
20.5-R25 XTLA L2, Radial	2603	102	-16	-1	-170	-376	-120	-264	-104	-230
20.5-R25 XHA L3, Radial	2674	105	+0	+0	+0	+0	+0	+0	+0	+0
20.5 R25 GP2B L3, Radial	2619	103	+6	+0	-53	-116	-37	-81	-32	-71
20.5 R25 HRL L3, Radial	2618	103	+23	+1	-48	-107	-34	-75	-30	-65
20.5 R25 RL-2+ L3, Radial	2609	103	+12	+0	+13	+28	+9	+20	+8	+17
650/65R-25 XLD L3, Radial (Low Profile)	2733	108	+0	+0	+519	+1145	+364	+803	+318	+701
20.5-25 SRG LD L3, Bias (16 ply)	2558	101	+8	+0	-242	-533	-170	-374	-148	-326
20.5-25 SRG LD L3, Bias (20 ply)	2556	101	+11	+0	-174	-384	-122	-270	-107	-235
20.5-25 RM 99 L3, Bias	2540	100	+8	+0	-58	-129	-41	-90	-36	-79

\*\*\*Without bulge.

Bucket Type		General Purpose — Fusion QC						Material Handling — Fusion QC		
		Bolt-on Edges	Teeth & Segments	Teeth	Bolt-on Edges	Teeth & Segments	Teeth	Bolt-on Edges	Teeth & Segments	Teeth
Capacity — rated	m <sup>3</sup>	2.5	2.5	2.3	3.1	3.1	2.9	2.5	2.5	2.3
	yd <sup>3</sup>	3.3	3.3	3.0	4.1	4.1	3.8	3.3	3.3	3.0
Capacity — struck	m <sup>3</sup>	2.1	2.1	1.9	2.5	2.5	2.4	2.1	2.1	1.9
	yd <sup>3</sup>	2.7	2.7	2.5	3.3	3.3	3.2	2.7	2.7	2.5
Width	mm	2700	2777	2777	2700	2777	2777	2700	2777	2777
	ft/in	8'10"	9'1"	9'1"	8'10"	9'1"	9'1"	8'10"	9'1"	9'1"
Dump clearance at maximum lift and 45° discharge	mm	2818	2713	2713	2712	2605	2605	2761	2647	2647
	ft/in	9'2"	8'10"	8'10"	8'10"	8'6"	8'6"	9'0"	8'8"	8'8"
Reach at maximum lift and 45° discharge	mm	1231	1334	1334	1313	1414	1414	1135	1229	1229
	ft/in	4'0"	4'4"	4'4"	4'3"	4'7"	4'7"	3'8"	4'0"	4'0"
Reach at level lift arm and bucket level	mm	2497	2644	2644	2635	2782	2782	2494	2641	2641
	ft/in	8'2"	8'8"	8'8"	8'7"	9'1"	9'1"	8'2"	8'7"	8'7"
Digging depth	mm	110	110	85	110	110	85	110	110	85
	in	4.31	4.31	3.33	4.31	4.31	3.33	4.31	4.31	3.33
Overall length	mm	7601	7760	7760	7739	7898	7898	7598	7757	7757
	ft/in	24'11"	25'5"	25'5"	25'4"	25'10"	25'10"	24'11"	25'5"	25'5"
Overall height with bucket at maximum lift	mm	5200	5200	5200	5358	5358	5358	5185	5185	5185
	ft/in	17'0"	17'0"	17'0"	17'6"	17'6"	17'6"	17'0"	17'0"	17'0"
Loader clearance circle with bucket at carry position	mm	12 195	12 373	12 373	12 279	12 459	12 459	12 193	12 371	12 371
	ft/in	40'0"	40'7"	40'7"	40'3"	40'10"	40'10"	40'0"	40'7"	40'7"
Static tipping load — straight*	kg	10 436	10 342	10 549	10 195	10 099	10 304	10 499	10 405	10 609
	lb	23,001	22,794	23,250	22,471	22,259	22,709	23,140	22,933	23,383
Static tipping load — articulated* maximum 40° turn	kg	8981	8887	9082	8756	8660	8852	9049	8955	9147
	lb	19,795	19,588	20,016	19,297	19,086	19,509	19,944	19,738	20,161
Breakout force**	kN	122	122	130	109	108	115	123	123	131
	lb	27,514	27,376	29,314	24,460	24,320	25,899	27,709	27,572	29,527
Operating weight*	kg	16 266	16 341	16 248	16 377	16 452	16 359	16 165	16 240	16 147
	lb	35,850	36,015	35,810	36,095	36,260	36,055	35,628	35,794	35,589

\*Static tipping loads and operating weight are based on the following loader configuration: L3 Michelin XHA tires, air conditioning, ride control, power train guard, full fluids, fuel tank, coolant, lubricants and operator.

Static tipping loads conform to the international standard as defined in ISO 14397-1 (SEPT2007).

\*\*Measured 100 mm (4") behind tip of cutting edge with bucket hinge pin as pivot point in accordance with SAE J732 (APR2007).

**NOTE:** Specifications and ratings conform to all applicable standards recommended by the Society of Automotive Engineers, including SAE Standard J732 (APR2007) which governs loader ratings.

	Width over tires maximum (loaded)		Change in vertical dimensions		Change in operating weight without ballast		Change in static tipping load — straight		Change in static tipping load — articulated	
	mm	in	mm	in	kg	lb	kg	lb	kg	lb
20.5-R25 XTLA L2, Radial	2603	102	-16	-1	-170	-376	-100	-219	-86	-191
20.5-R25 XHA L3, Radial	2674	105	+0	+0	+0	+0	+0	+0	+0	+0
20.5 R25 GP2B L3, Radial	2619	103	+6	+0	-53	-116	-31	-67	-27	-59
20.5 R25 HRL L3, Radial	2618	103	+23	+1	-48	-107	-28	-62	-25	-54
20.5 R25 RL-2+ L3, Radial	2609	103	+12	+0	+13	+28	+7	+17	+7	+14
650/65R-25 XLD L3, Radial (Low Profile)	2733	108	+0	+0	+519	+1145	+302	+666	+264	+582
20.5-25 SRG LD L3, Bias (16 ply)	2558	101	+8	+0	-242	-533	-141	-310	-123	-271
20.5-25 SRG LD L3, Bias (20 ply)	2556	101	+11	+0	-174	-384	-101	-224	-89	-195
20.5-25 RM 99 L3, Bias	2540	100	+8	+0	-58	-129	-34	-75	-30	-66

\*\*\*Without bulge.

Bucket Type		Material Handling — Fusion QC								
		Bolt-on Edges	Teeth & Segments	Teeth	Bolt-on Edges	Teeth & Segments	Teeth	Bolt-on Edges	Teeth & Segments	Teeth
Capacity — rated	m³	2.7	2.7	2.5	2.9	2.9	2.7	3.1	3.1	2.9
	yd³	3.5	3.5	3.3	3.8	3.8	3.5	4.1	4.1	3.8
Capacity — struck	m³	2.2	2.2	2.1	2.4	2.4	2.3	2.6	2.6	2.4
	yd³	2.9	2.9	2.8	3.1	3.1	3.0	3.4	3.4	3.2
Width	mm	2700	2777	2777	2700	2777	2777	2700	2777	2777
	ft/in	8'10"	9'1"	9'1"	8'10"	9'1"	9'1"	8'10"	9'1"	9'1"
Dump clearance at maximum lift and 45° discharge	mm	2726	2612	2612	2694	2580	2580	2661	2547	2547
	ft/in	8'11"	8'6"	8'6"	8'10"	8'5"	8'5"	8'8"	8'4"	8'4"
Reach at maximum lift and 45° discharge	mm	1169	1263	1263	1201	1295	1295	1235	1329	1329
	ft/in	3'10"	4'1"	4'1"	3'11"	4'2"	4'2"	4'0"	4'4"	4'4"
Reach at level lift arm and bucket level	mm	2543	2690	2690	2588	2735	2735	2635	2782	2782
	ft/in	8'4"	8'9"	8'9"	8'5"	8'11"	8'11"	8'7"	9'1"	9'1"
Digging depth	mm	110	110	85	110	110	85	110	110	85
	in	4.31	4.31	3.33	4.31	4.31	3.33	4.31	4.31	3.33
Overall length	mm	7647	7806	7806	7692	7851	7851	7739	7898	7898
	ft/in	25'1"	25'7"	25'7"	25'2"	25'9"	25'9"	25'4"	25'10"	25'10"
Overall height with bucket at maximum lift	mm	5242	5242	5242	5294	5294	5294	5346	5346	5346
	ft/in	17'2"	17'2"	17'2"	17'4"	17'4"	17'4"	17'6"	17'6"	17'6"
Loader clearance circle with bucket at carry position	mm	12 223	12 401	12 401	12 250	12 430	12 430	12 279	12 459	12 459
	ft/in	40'1"	40'8"	40'8"	40'2"	40'9"	40'9"	40'3"	40'10"	40'10"
Static tipping load — straight*	kg	10 420	10 325	10 529	10 348	10 253	10 456	10 275	10 179	10 381
	lb	22,965	22,757	23,206	22,808	22,598	23,045	22,645	22,434	22,880
Static tipping load — articulated* maximum 40° turn	kg	8975	8881	9073	8909	8814	9005	8840	8744	8935
	lb	19,782	19,574	19,996	19,635	19,426	19,846	19,484	19,273	19,693
Breakout force**	kN	118	118	126	114	113	121	110	109	116
	lb	26,553	26,414	28,227	25,566	25,427	27,123	24,605	24,464	26,051
Operating weight*	kg	16 198	16 273	16 180	16 227	16 302	16 209	16 258	16 333	16 240
	lb	35,700	35,865	35,660	35,765	35,931	35,726	35,832	36,397	35,792

\*Static tipping loads and operating weight are based on the following loader configuration: L3 Michelin XHA tires, air conditioning, ride control, power train guard, full fluids, fuel tank, coolant, lubricants and operator.

Static tipping loads conform to the international standard as defined in ISO 14397-1 (SEPT2007).

\*\*Measured 100 mm (4") behind tip of cutting edge with bucket hinge pin as pivot point in accordance with SAE J732 (APR2007).

**NOTE:** Specifications and ratings conform to all applicable standards recommended by the Society of Automotive Engineers, including SAE Standard J732 (APR2007) which governs loader ratings.

	Width over tires maximum (loaded)		Change in vertical dimensions		Change in operating weight without ballast		Change in static tipping load — straight		Change in static tipping load — articulated	
	mm	in	mm	in	kg	lb	kg	lb	kg	lb
20.5-R25 XTLA L2, Radial	2603	102	-16	-1	-170	-376	-100	-219	-86	-191
20.5-R25 XHA L3, Radial	2674	105	+ 0	+0	+ 0	+ 0	+ 0	+ 0	+ 0	+ 0
20.5 R25 GP2B L3, Radial	2619	103	+ 6	+0	- 53	- 116	- 31	- 67	- 27	- 59
20.5 R25 HRL L3, Radial	2618	103	+23	+1	- 48	- 107	- 28	- 62	- 25	- 54
20.5 R25 RL-2+ L3, Radial	2609	103	+12	+0	+ 13	+ 28	+ 7	+ 17	+ 7	+ 14
650/65R-25 XLD L3, Radial (Low Profile)	2733	108	+ 0	+0	+519	+1145	+302	+666	+264	+582
20.5-25 SRG LD L3, Bias (16 ply)	2558	101	+ 8	+0	-242	- 533	-141	-310	-123	-271
20.5-25 SRG LD L3, Bias (20 ply)	2556	101	+11	+0	-174	- 384	-101	-224	- 89	-195
20.5-25 RM 99 L3, Bias	2540	100	+ 8	+0	- 58	- 129	- 34	- 75	- 30	- 66

\*\*\*Without bulge.



Bucket Type	General Purpose — Pin On									High Lift Delta	
	Edge Type	Bolt-on Edges	Teeth & Seg-ments	Teeth	Bolt-on Edges	Teeth & Seg-ments	Teeth	Bolt-on Edges	Teeth & Seg-ments		Teeth
Capacity — rated	m <sup>3</sup> yd <sup>3</sup>	2.7 3.5	2.7 3.5	2.5 3.3	2.9 3.8	2.9 3.8	2.7 3.5	3.1 4.1	3.1 4.1	2.9 3.8	— —
Capacity — struck	m <sup>3</sup> yd <sup>3</sup>	2.3 3.0	2.3 3.0	2.1 2.8	2.5 3.2	2.5 3.2	2.3 3.0	2.7 3.5	2.7 3.5	2.5 3.3	— —
Width	mm ft/in	2927 9'7"	2994 9'9"	2994 9'9"	2927 9'7"	2994 9'9"	2994 9'9"	2927 9'7"	2994 9'9"	2994 9'9"	— —
Dump clearance at maximum lift and 45° discharge	mm ft/in	2974 9'9"	2871 9'5"	2871 9'5"	2926 9'7"	2822 9'3"	2822 9'3"	2880 9'5"	2762 9'0"	2762 9'0"	+495 +1'7"
Reach at maximum lift and 45° discharge	mm ft/in	1214 3'11"	1313 4'3"	1313 4'3"	1247 4'1"	1345 4'4"	1345 4'4"	1283 4'2"	1394 4'6"	1394 4'6"	+36 +1.4"
Reach at level lift arm and bucket level	mm ft/in	2465 8'1"	2607 8'6"	2607 8'6"	2525 8'3"	2667 8'8"	2667 8'8"	2585 8'5"	2746 9'0"	2746 9'0"	+374 +1'3"
Digging depth	mm in	92 3.6	97 3.8	62 2.4	92 3.6	97 3.8	62 2.4	92 3.6	97 3.8	62 2.4	+21 +0.8
Overall length	mm ft/in	7897 25'10"	8052 26'5"	8052 26'5"	7957 26'1"	8112 26'7"	8112 26'7"	8017 26'3"	8191 26'10"	8191 26'10"	+604 +2'0"
Overall height with bucket at maximum lift	mm ft/in	5329 17'5"	5329 17'5"	5329 17'5"	5386 17'8"	5386 17'8"	5386 17'8"	5443 17'10"	5443 17'10"	5443 17'10"	+495 +1'7"
Loader clearance circle with bucket at carry position	mm ft/in	13 267 43'6"	13 418 44'0"	13 418 44'0"	13 299 43'7"	13 450 44'1"	13 450 44'1"	13 331 43'8"	13 494 44'3"	13 494 44'3"	+387 +1'3"
Static tipping load — straight*	kg lb	12 393 27,315	12 281 27,067	12 570 27,704	12 276 27,057	12 163 26,808	12 449 27,437	12 161 26,804	12 048 26,555	12 330 27,176	-293 -647
Static tipping load — articulated* maximum 40° turn	kg lb	10 691 23,564	10 579 23,316	10 849 23,912	10 581 23,320	10 468 23,072	10 735 23,661	10 473 23,082	10 360 22,833	10 624 23,415	-375 -825
Breakout force**	kN lb	174 39,065	173 38,900	191 42,907	164 36,923	164 36,760	180 40,353	156 34,985	155 34,822	169 38,064	-9 -1964
Operating weight*	kg lb	18 091 39,873	18 198 40,109	18 041 39,763	18 145 39,992	18 252 40,228	18 095 39,882	18 197 40,106	18 304 40,342	18 147 39,996	+1270 +2799

\*Static tipping loads and operating weight are based on the following loader configuration: L3 Michelin XHA tires, air conditioning, ride control, power train guard, full fluids, fuel tank, coolant, lubricants and operator.

Static tipping loads conform to the international standard as defined in ISO 14397-1 (SEPT2007).

\*\*Measured 100 mm (4") behind tip of cutting edge with bucket hinge pin as pivot point in accordance with SAE J732 (APR2007).

**NOTE:** Specifications and ratings conform to all applicable standards recommended by the Society of Automotive Engineers, including SAE Standard J732 (APR2007) which governs loader ratings.

	Width over tires		Change in vertical dimensions		Change in operating weight		Change in static tipping load	
	mm	in	mm	in	kg	lb	kg	lb
	23.5R25 VSW BS L2, Radial	2862	113	+ 6	+0	+ 20	+ 44	+ 14
23.5R25 VUT D2A BS L2, Radial	2866	113	+10	+0	- 41	- 90	- 29	- 64
23.5R25 XTLA MX L2, Radial	2801	110	+ 7	+0	-112	- 247	- 79	- 174
23.5R25 VMT BS L3, Radial	2851	112	+ 3	+0	+124	+ 273	+ 88	+ 194
23.5R25 XHA MX L3, Radial	2784	110	+ 0	+0	+ 0	+ 0	+ 0	+ 0
23.5R25 XMINE MX L5, Radial	2807	111	+26	+1	+872	+1923	+619	+1365
750/65R25 XLD MX L3, Radial	2879	113	+ 7	+0	+460	+1014	+326	+ 719
23.5-25 SGGL FS L2, Bias	2834	112	+14	+1	-472	-1041	-335	- 739

Bucket Type	General Purpose — Pin On						Material Handling — Pin On			High Lift Delta	
	Edge Type	Bolt-on Edges	Teeth & Seg-ments	Teeth	Bolt-on Edges	Teeth & Seg-ments	Teeth	Bolt-on Edges	Teeth & Seg-ments		Teeth
Capacity — rated	m <sup>3</sup> yd <sup>3</sup>	3.3 4.3	3.3 4.3	3.1 4.1	3.5 4.6	3.5 4.6	3.3 4.3	3.1 4.1	3.1 4.1	2.9 3.8	— —
Capacity — struck	m <sup>3</sup> yd <sup>3</sup>	2.8 3.7	2.8 3.7	2.7 3.5	3.0 3.9	3.0 3.9	2.8 3.7	2.7 3.5	2.7 3.5	2.5 3.3	— —
Width	mm ft/in	2927 9'7"	2994 9'9"	2994 9'9"	2946 9'8"	2946 9'8"	2896 9'6"	2927 9'7"	2994 9'9"	2994 9'9"	— —
Dump clearance at maximum lift and 45° discharge	mm ft/in	2917 9'6"	2811 9'2"	2811 9'2"	2812 9'2"	2706 8'10"	2706 8'10"	2870 9'5"	2758 9'0"	2758 9'0"	+495 +1'7"
Reach at maximum lift and 45° discharge	mm ft/in	1227 4'0"	1322 4'4"	1322 4'4"	1340 4'4"	1436 4'8"	1436 4'8"	1155 3'9"	1244 4'0"	1244 4'0"	+36 +1.4"
Reach at level lift arm and bucket level	mm ft/in	2520 8'3"	2662 8'8"	2662 8'8"	2675 8'9"	2818 9'2"	2818 9'2"	2520 8'3"	2662 8'8"	2662 8'8"	+374 +1'3"
Digging depth	mm in	92 3.6	97 3.8	62 2.4	92 3.6	97 3.8	62 2.4	92 3.6	97 3.8	62 2.4	+21 +0.8
Overall length	mm ft/in	7952 26'1"	8107 26'7"	8107 26'7"	8107 26'7"	8263 27'1"	8263 27'1"	7952 26'1"	8107 26'7"	8107 26'7"	+604 +2'0"
Overall height with bucket at maximum lift	mm ft/in	5491 18'0"	5491 18'0"	5491 18'0"	5379 17'7"	5379 17'7"	5379 17'7"	5391 17'8"	5391 17'8"	5391 17'8"	+495 +1'7"
Loader clearance circle with bucket at carry position	mm ft/in	13 296 43'7"	13 448 44'1"	13 448 44'1"	13 398 43'11"	13 492 44'3"	13 446 44'1"	13 296 43'7"	13 448 44'1"	13 448 44'1"	+387 +1'3"
Static tipping load — straight*	kg lb	12 052 26,563	11 939 26,313	12 215 26,923	12 266 27,033	12 295 27,099	12 308 27,126	12 485 27,517	12 371 27,265	12 663 27,908	-293 -647
Static tipping load — articulated* maximum 40° turn	kg lb	10 369 22,853	10 256 22,603	10 515 23,175	10 590 23,340	10 600 23,362	10 632 23,433	10 769 23,734	10 654 23,482	10 928 24,085	-375 -825
Breakout force**	kN lb	164 36,734	163 36,555	179 40,163	147 33,016	146 32,860	159 35,735	165 37,048	164 36,879	180 40,512	-9 -1964
Operating weight*	kg lb	18 262 40,250	18 369 40,485	18 212 40,139	18 068 39,822	18 176 40,059	18 019 39,713	18 085 39,860	18 192 40,095	18 035 39,749	+1270 +2799

\*Static tipping loads and operating weight are based on the following loader configuration: L3 Michelin XHA tires, air conditioning, ride control, power train guard, full fluids, fuel tank, coolant, lubricants and operator.

Static tipping loads conform to the international standard as defined in ISO 14397-1 (SEPT2007).

\*\*Measured 100 mm (4") behind tip of cutting edge with bucket hinge pin as pivot point in accordance with SAE J732 (APR2007).

**NOTE:** Specifications and ratings conform to all applicable standards recommended by the Society of Automotive Engineers, including SAE Standard J732 (APR2007) which governs loader ratings.

	Width over tires		Change in vertical dimensions		Change in operating weight		Change in static tipping load	
	mm	in	mm	in	kg	lb	kg	lb
	23.5R25 VSW BS L2, Radial	2862	113	+ 6	+0	+ 20	+ 44	+ 14
23.5R25 VUT D2A BS L2, Radial	2866	113	+10	+0	- 41	- 90	- 29	- 64
23.5R25 XTLA MX L2, Radial	2801	110	+ 7	+0	-112	- 247	- 79	- 174
23.5R25 VMT BS L3, Radial	2851	112	+ 3	+0	+124	+ 273	+ 88	+ 194
23.5R25 XHA MX L3, Radial	2784	110	+ 0	+0	+ 0	+ 0	+ 0	+ 0
23.5R25 XMINE MX L5, Radial	2807	111	+26	+1	+872	+1923	+619	+1365
750/65R25 XLD MX L3, Radial	2879	113	+ 7	+0	+460	+1014	+326	+ 719
23.5-25 SGGL FS L2, Bias	2834	112	+14	+1	-472	-1041	-335	- 739

Bucket Type		Material Handling — Pin On						General Purpose — Fusion QC			High Lift Delta
		Bolt-on Edges	Teeth & Seg-ments	Teeth	Bolt-on Edges	Teeth & Seg-ments	Teeth	Bolt-on Edges	Teeth & Seg-ments	Teeth	
Edge Type											
Capacity — rated	m <sup>3</sup> yd <sup>3</sup>	3.3 4.3	3.3 4.3	3.1 4.1	3.5 4.6	3.5 4.6	3.3 4.3	3.1 4.1	3.1 4.1	2.9 3.8	— —
Capacity — struck	m <sup>3</sup> yd <sup>3</sup>	2.8 3.7	2.8 3.7	2.7 3.5	3.0 3.9	3.0 3.9	2.8 3.7	2.3 3.0	2.3 3.0	2.1 2.8	— —
Width	mm ft/in	2927 9'7"	2994 9'9"	2994 9'9"	2927 9'7"	2994 9'9"	2994 9'9"	2927 9'7"	2994 9'9"	2994 9'9"	— —
Dump clearance at maximum lift and 45° discharge	mm ft/in	2835 9'3"	2723 8'11"	2723 8'11"	2800 9'2"	2688 8'9"	2688 8'9"	2895 9'5"	2794 9'1"	2794 9'1"	+495 +1'7"
Reach at maximum lift and 45° discharge	mm ft/in	1190 3'10"	1279 4'2"	1279 4'2"	1226 4'0"	1314 4'3"	1314 4'3"	1337 4'4"	1437 4'8"	1437 4'8"	+36 +1.4"
Reach at level lift arm and bucket level	mm ft/in	2570 8'5"	2712 8'10"	2712 8'10"	2620 8'7"	2762 9'0"	2762 9'0"	2604 8'6"	2746 9'0"	2746 9'0"	+374 +1'3"
Digging depth	mm in	92 3.6	97 3.8	62 2.4	92 3.6	97 3.8	62 2.4	100 3.9	100 3.9	70 2.7	+21 +0.8
Overall length	mm ft/in	8002 26'3"	8157 26'9"	8157 26'9"	8052 26'5"	8207 26'11"	8207 26'11"	8042 26'4"	8197 26'10"	8197 26'10"	+604 +2'0"
Overall height with bucket at maximum lift	mm ft/in	5436 17'10"	5436 17'10"	5436 17'10"	5482 17'11"	5482 17'11"	5482 17'11"	5367 17'7"	5367 17'7"	5367 17'7"	+495 +1'7"
Loader clearance circle with bucket at carry position	mm ft/in	13 323 43'8"	13 475 44'2"	13 475 44'2"	13 350 43'9"	13 503 44'3"	13 503 44'3"	13 340 43'9"	13 493 44'3"	13 493 44'3"	+387 +1'3"
Static tipping load — straight*	kg lb	12 383 27,293	12 269 27,040	12 557 27,676	12 280 27,066	12 165 26,813	12 451 27,443	11 999 26,447	11 859 26,138	12 193 26,874	-293 -647
Static tipping load — articulated* maximum 40° turn	kg lb	10 673 23,524	10 559 23,271	10 829 23,868	10 577 23,311	10 462 23,058	10 730 23,648	10 295 22,689	10 155 22,381	10 470 23,076	-375 -825
Breakout force**	kN lb	158 35,396	157 35,226	172 38,558	151 33,867	150 33,697	164 36,765	154 34,515	152 34,246	167 37,583	-9 -1964
Operating weight*	kg lb	18 126 39,950	18 233 40,186	18 076 39,840	18 168 40,042	18 275 40,278	18 118 39,932	18 561 40,909	18 669 41,147	18 512 40,801	+1270 +2799

\*Static tipping loads and operating weight are based on the following loader configuration: L3 Michelin XHA tires, air conditioning, ride control, power train guard, full fluids, fuel tank, coolant, lubricants and operator.

Static tipping loads conform to the international standard as defined in ISO 14397-1 (SEPT2007).

\*\*Measured 100 mm (4") behind tip of cutting edge with bucket hinge pin as pivot point in accordance with SAE J732 (APR2007).

**NOTE:** Specifications and ratings conform to all applicable standards recommended by the Society of Automotive Engineers, including SAE Standard J732 (APR2007) which governs loader ratings.

	Width over tires		Change in vertical dimensions		Change in operating weight		Change in static tipping load	
	mm	in	mm	in	kg	lb	kg	lb
	23.5R25 VSW BS L2, Radial	2862	113	+ 6	+0	+ 20	+ 44	+ 14
23.5R25 VUT D2A BS L2, Radial	2866	113	+10	+0	- 41	- 90	- 29	- 64
23.5R25 XTLA MX L2, Radial	2801	110	+ 7	+0	-112	- 247	- 79	- 174
23.5R25 VMT BS L3, Radial	2851	112	+ 3	+0	+124	+ 273	+ 88	+ 194
23.5R25 XHA MX L3, Radial	2784	110	+ 0	+0	+ 0	+ 0	+ 0	+ 0
23.5R25 XMINE MX L5, Radial	2807	111	+26	+1	+872	+1923	+619	+1365
750/65R25 XLD MX L3, Radial	2879	113	+ 7	+0	+460	+1014	+326	+ 719
23.5-25 SGGL FS L2, Bias	2834	112	+14	+1	-472	-1041	-335	- 739

Bucket Type	General Purpose — Fusion QC			Material Handling — Fusion QC			Rock — Pin On		Waste — Pin On	High Lift Delta	
	Edge Type	Bolt-on Edges	Teeth & Segments	Teeth	Bolt-on Edges	Teeth & Segments	Teeth	Bolt-on Edges	Bottom Strap Teeth		Bolt-on Edges
Capacity — rated	m <sup>3</sup> yd <sup>3</sup>	3.4 4.5	3.4 4.5	3.3 4.3	3.4 4.5	3.4 4.5	3.3 4.3	2.9 3.8	2.9 3.8	5.2 6.8	— —
Capacity — struck	m <sup>3</sup> yd <sup>3</sup>	2.6 3.4	2.6 3.4	2.4 3.2	2.7 3.5	2.7 3.5	2.5 3.3	2.5 3.2	2.4 3.2	— —	— —
Width	mm ft/in	2927 9'7"	2994 9'9"	2994 9'9"	2927 9'7"	2994 9'9"	2994 9'9"	2984 9'9"	2969 9'8"	3073 10'1"	— —
Dump clearance at maximum lift and 45° discharge	mm ft/in	2812 9'2"	2708 8'10"	2708 8'10"	2794 9'1"	2682 8'9"	2682 8'9"	2871 9'5"	2712 8'10"	2715 8'10"	+495 +1'7"
Reach at maximum lift and 45° discharge	mm ft/in	1392 4'6"	1490 4'10"	1490 4'10"	1220 4'0"	1309 4'3"	1309 4'3"	1329 4'4"	1457 4'9"	1310 4'3"	+36 +1.4"
Reach at level lift arm and bucket level	mm ft/in	2706 8'10"	2848 9'4"	2848 9'4"	2620 8'7"	2762 9'0"	2762 9'0"	2620 8'7"	2821 9'3"	2739 8'11"	+374 +1'3"
Digging depth	mm in	100 3.9	100 3.9	70 2.7	100 3.9	100 3.9	70 2.7	92 3.6	62 2.4	92 3.6	+21 +0.8
Overall length	mm ft/in	8144 26'8"	8299 27'2"	8299 27'2"	8058 26'5"	8213 26'11"	8213 26'11"	8052 26'5"	8284 27'2"	8171 26'9"	+604 +2'0"
Overall height with bucket at maximum lift	mm ft/in	5464 17'11"	5464 17'11"	5464 17'11"	5460 17'10"	5460 17'10"	5460 17'10"	5391 17'8"	5391 17'8"	6005 19'8"	+495 +1'7"
Loader clearance circle with bucket at carry position	mm ft/in	13 397 43'11"	13 552 44'5"	13 552 44'5"	13 348 43'9"	13 502 44'3"	13 502 44'3"	13 402 43'11"	13 533 44'4"	13 549 44'5"	+387 +1'3"
Static tipping load — straight*	kg lb	11 811 26,033	11 670 25,721	11 996 26,440	11 951 26,339	11 810 26,030	12 138 26,752	12 157 26,795	12 293 27,093	12 216 26,923	-293 -647
Static tipping load — articulated* maximum 40° turn	kg lb	10 118 22,300	9976 21,988	10 286 22,670	10 247 22,584	10 107 22,275	10 417 22,959	10 439 23,006	10 570 23,296	10 423 22,973	-375 -825
Breakout force**	kN lb	141 31,708	140 31,442	153 34,312	151 33,991	150 33,723	165 36,974	151 33,833	159 35,648	135 30,294	-9 -1964
Operating weight*	kg lb	18 649 41,103	18 757 41,341	18 600 40,995	18 604 41,003	18 712 41,241	18 555 40,895	18 399 40,552	18 316 40,369	18 861 41,570	+1270 +2799

\*Static tipping loads and operating weight are based on the following loader configuration: L3 Michelin XHA tires, air conditioning, ride control, power train guard, full fluids, fuel tank, coolant, lubricants and operator.

Static tipping loads conform to the international standard as defined in ISO 14397-1 (SEPT2007).

\*\*Measured 100 mm (4") behind tip of cutting edge with bucket hinge pin as pivot point in accordance with SAE J732 (APR2007).

**NOTE:** Specifications and ratings conform to all applicable standards recommended by the Society of Automotive Engineers, including SAE Standard J732 (APR2007) which governs loader ratings.

	Width over tires		Change in vertical dimensions		Change in operating weight		Change in static tipping load	
	mm	in	mm	in	kg	lb	kg	lb
23.5R25 VSW BS L2, Radial	2862	113	+ 6	+0	+ 20	+ 44	+ 14	+ 31
23.5R25 VUT D2A BS L2, Radial	2866	113	+10	+0	- 41	- 90	- 29	- 64
23.5R25 XTLA MX L2, Radial	2801	110	+ 7	+0	-112	- 247	- 79	- 174
23.5R25 VMT BS L3, Radial	2851	112	+ 3	+0	+124	+ 273	+ 88	+ 194
23.5R25 XHA MX L3, Radial	2784	110	+ 0	+0	+ 0	+ 0	+ 0	+ 0
23.5R25 XMINE MX L5, Radial	2807	111	+26	+1	+872	+1923	+619	+1365
750/65R25 XLD MX L3, Radial	2879	113	+ 7	+0	+460	+1014	+326	+ 719
23.5-25 SGGL FS L2, Bias	2834	112	+14	+1	-472	-1041	-335	- 739

Bucket Type		General Purpose — Pin On						SL Lift Delta	High Lift Delta
		Bolt-on Edges	Teeth & Segments	Teeth	Bolt-on Edges	Teeth & Segments	Teeth		
Capacity — rated	m <sup>3</sup>	2.9	2.9	2.7	3.1	3.1	2.9	—	—
	yd <sup>3</sup>	<b>3.8</b>	<b>3.8</b>	<b>3.5</b>	<b>4.1</b>	<b>4.1</b>	<b>3.8</b>	—	—
Capacity — struck	m <sup>3</sup>	2.5	2.5	2.3	2.7	2.7	2.5	—	—
	yd <sup>3</sup>	<b>3.2</b>	<b>3.2</b>	<b>3.0</b>	<b>3.5</b>	<b>3.5</b>	<b>3.3</b>	—	—
Width	mm	2927	2994	2994	2927	2994	2994	—	—
	ft/in	<b>9'7"</b>	<b>9'9"</b>	<b>9'9"</b>	<b>9'7"</b>	<b>9'9"</b>	<b>9'9"</b>	—	—
Dump clearance at maximum lift and 45° discharge	mm	3116	3012	3012	3070	2952	2952	-190	+305
	ft/in	<b>10'2"</b>	<b>9'10"</b>	<b>9'10"</b>	<b>10'0"</b>	<b>9'8"</b>	<b>9'8"</b>	<b>+4"</b>	<b>+1'0"</b>
Reach at maximum lift and 45° discharge	mm	1165	1263	1263	1201	1312	1312	+82	+118
	ft/in	<b>3'9"</b>	<b>4'1"</b>	<b>4'1"</b>	<b>3'11"</b>	<b>4'3"</b>	<b>4'3"</b>	<b>+3"</b>	<b>+4"</b>
Reach at level lift arm and bucket level	mm	2593	2735	2735	2653	2814	2814	-68	+306
	ft/in	<b>8'6"</b>	<b>8'11"</b>	<b>8'11"</b>	<b>8'8"</b>	<b>9'2"</b>	<b>9'2"</b>	<b>+2"</b>	<b>+1'0"</b>
Digging depth	mm	92	97	62	92	97	62	+0	+21
	in	<b>3.6"</b>	<b>3.8"</b>	<b>2.4"</b>	<b>3.6"</b>	<b>3.8"</b>	<b>2.4"</b>	<b>+0</b>	<b>+1"</b>
Overall length	mm	8187	8341	8341	8247	8420	8420	-127	+374
	ft/in	<b>26'10"</b>	<b>27'4"</b>	<b>27'4"</b>	<b>27'0"</b>	<b>27'7"</b>	<b>27'7"</b>	<b>+4"</b>	<b>+1'2"</b>
Overall height with bucket at maximum lift	mm	5576	5576	5576	5633	5633	5633	-190	+305
	ft/in	<b>18'3"</b>	<b>18'3"</b>	<b>18'3"</b>	<b>18'5"</b>	<b>18'5"</b>	<b>18'5"</b>	<b>+7"</b>	<b>+1'0"</b>
Loader clearance circle with bucket at carry position	mm	13 413	13 569	13 569	13 447	13 615	13 615	-119	+269
	ft/in	<b>44'0"</b>	<b>44'6"</b>	<b>44'6"</b>	<b>44'1"</b>	<b>44'8"</b>	<b>44'8"</b>	<b>+4"</b>	<b>+10"</b>
Static tipping load — straight*	kg	13 146	13 033	13 324	13 028	12 915	13 202	+744	-2603
	lb	<b>28,973</b>	<b>28,726</b>	<b>29,366</b>	<b>28,713</b>	<b>28,465</b>	<b>29,097</b>	<b>+1641</b>	<b>-5737</b>
Static tipping load — articulated* maximum 40° turn	kg	11 232	11 119	11 390	11 121	11 008	11 276	+657	-2297
	lb	<b>24,755</b>	<b>24,507</b>	<b>25,104</b>	<b>24,510</b>	<b>24,262</b>	<b>24,852</b>	<b>+1405</b>	<b>-5062</b>
Breakout force**	kN	165	165	181	157	156	171	-1	-9
	lb	<b>37,160</b>	<b>37,004</b>	<b>40,620</b>	<b>35,210</b>	<b>35,054</b>	<b>38,316</b>	<b>-210</b>	<b>-2042</b>
Operating weight*	kg	18 890	18 997	18 840	18 942	19 049	18 892	+8	+544
	lb	<b>41,633</b>	<b>41,869</b>	<b>41,523</b>	<b>41,748</b>	<b>41,984</b>	<b>41,638</b>	<b>+8</b>	<b>+1199</b>

\*Static tipping loads and operating weight are based on the following loader configuration: L3 Michelin XHA tires, air conditioning, ride control, power train guard, full fluids, fuel tank, coolant, lubricants and operator.

Static tipping loads conform to the international standard as defined in ISO 14397-1 (SEPT2007).

\*\*Measured 100 mm (4") behind tip of cutting edge with bucket hinge pin as pivot point in accordance with SAE J732 (APR2007).

**NOTE:** Specifications and ratings conform to all applicable standards recommended by the Society of Automotive Engineers, including SAE Standard J732 (APR2007) which governs loader ratings.

	Width over tires		Change in vertical dimensions		Change in operating weight		Change in static tipping load	
	mm	in	mm	in	kg	lb	kg	lb
	23.5R25 VSW BS L2, Radial	2862	<b>113</b>	+ 6	<b>+0</b>	+ 20	+ <b>44</b>	+ 14
23.5R25 VUT D2A BS L2, Radial	2866	<b>113</b>	+10	<b>+0</b>	- 41	- <b>90</b>	- 29	- <b>64</b>
23.5R25 XTLA MX L2, Radial	2801	<b>110</b>	+ 7	<b>+0</b>	-112	- <b>247</b>	- 79	- <b>174</b>
23.5R25 VMT BS L3, Radial	2851	<b>112</b>	+ 3	<b>+0</b>	+124	+ <b>273</b>	+ 88	+ <b>194</b>
23.5R25 XHA MX L3, Radial	2784	<b>110</b>	+ 0	<b>+0</b>	+ 0	+ <b>0</b>	+ 0	+ <b>0</b>
23.5R25 XMINE MX L5, Radial	2807	<b>111</b>	+26	<b>+1</b>	+872	+ <b>1923</b>	+619	+ <b>1365</b>
750/65R25 XLD MX L3, Radial	2879	<b>113</b>	+ 7	<b>+0</b>	+460	+ <b>1014</b>	+326	+ <b>719</b>
23.5-25 SGL FS L2, Bias	2834	<b>112</b>	+14	<b>+1</b>	-472	- <b>1041</b>	-335	- <b>739</b>

Bucket Type		General Purpose — Pin On						SL Lift Delta	High Lift Delta
		Bolt-on Edges	Teeth & Segments	Teeth	Bolt-on Edges	Teeth & Segments	Teeth		
Capacity — rated	m³	3.3	3.3	3.1	3.5	3.5	3.3	—	—
	yd³	4.3	4.3	4.1	4.6	4.6	4.3	—	—
Capacity — struck	m³	2.8	2.8	2.7	3.0	3.0	2.8	—	—
	yd³	3.7	3.7	3.5	3.9	3.9	3.6	—	—
Width	mm	2927	2994	2994	2946	2946	2896	—	—
	ft/in	9'7"	9'9"	9'9"	9'8"	9'8"	9'6"	—	—
Dump clearance at maximum lift and 45° discharge	mm	3032	2926	2926	3002	2896	2896	-190	+305
	ft/in	9'11"	9'7"	9'7"	9'10"	9'5"	9'5"	+4"	+1'0"
Reach at maximum lift and 45° discharge	mm	1231	1327	1327	1257	1354	1354	+82	+118
	ft/in	4'0"	4'4"	4'4"	4'1"	4'5"	4'5"	+3"	+4"
Reach at level lift arm and bucket level	mm	2703	2845	2845	2743	2886	2886	-68	+306
	ft/in	8'10"	9'4"	9'4"	8'11"	9'5"	9'5"	+2"	+1'0"
Digging depth	mm	92	97	62	92	97	62	+0	+21
	in	3.6"	3.8"	2.4"	3.6"	3.8"	2.4"	+0	+1"
Overall length	mm	8297	8451	8451	8337	8492	8492	-127	+374
	ft/in	27'2"	27'8"	27'8"	27'4"	27'10"	27'10"	+4"	+1'2"
Overall height with bucket at maximum lift	mm	5681	5681	5681	5569	5569	5569	-190	+305
	ft/in	18'7"	18'7"	18'7"	18'3"	18'3"	18'3"	+7"	+1'0"
Loader clearance circle with bucket at carry position	mm	13 476	13 633	13 633	13 517	13 615	13 570	-119	+269
	ft/in	44'2"	44'8"	44'8"	44'4"	44'8"	44'6"	+4"	+10"
Static tipping load — straight*	kg	12 915	12 802	13 084	13 122	13 158	13 165	+744	-2603
	lb	28,464	28,215	28,837	28,922	29,001	29,015	+1641	-5737
Static tipping load — articulated* maximum 40° turn	kg	11 014	10 901	11 164	11 230	11 244	11 272	+657	-2297
	lb	24,274	24,025	24,605	24,750	24,782	24,843	+1405	-5062
Breakout force**	kN	150	149	163	148	147	160	-1	-9
	lb	33,679	33,522	36,524	33,226	33,076	35,969	-210	-2042
Operating weight*	kg	19 007	19 114	18 957	18 813	18 920	18 763	+8	+544
	lb	41,891	42,127	41,781	41,464	41,700	41,354	+18	+1199

\*Static tipping loads and operating weight are based on the following loader configuration: L3 Michelin XHA tires, air conditioning, ride control, power train guard, full fluids, fuel tank, coolant, lubricants and operator.

Static tipping loads conform to the international standard as defined in ISO 14397-1 (SEPT2007).

\*\*Measured 100 mm (4") behind tip of cutting edge with bucket hinge pin as pivot point in accordance with SAE J732 (APR2007).

**NOTE:** Specifications and ratings conform to all applicable standards recommended by the Society of Automotive Engineers, including SAE Standard J732 (APR2007) which governs loader ratings.

	Width over tires		Change in vertical dimensions		Change in operating weight		Change in static tipping load	
	mm	in	mm	in	kg	lb	kg	lb
23.5R25 VSW BS L2, Radial	2862	113	+ 6	+0	+ 20	+ 44	+ 14	+ 31
23.5R25 VUT D2A BS L2, Radial	2866	113	+10	+0	- 41	- 90	- 29	- 64
23.5R25 XTLA MX L2, Radial	2801	110	+ 7	+0	-112	- 247	- 79	- 174
23.5R25 VMT BS L3, Radial	2851	112	+ 3	+0	+124	+ 273	+ 88	+ 194
23.5R25 XHA MX L3, Radial	2784	110	+ 0	+0	+ 0	+ 0	+ 0	+ 0
23.5R25 XMINE MX L5, Radial	2807	111	+26	+1	+872	+1923	+619	+1365
750/65R25 XLD MX L3, Radial	2879	113	+ 7	+0	+460	+1014	+326	+ 719
23.5-25 SGGL FS L2, Bias	2834	112	+14	+1	-472	-1041	-335	- 739

Bucket Type		General Purpose — Pin On			Material Handling — Pin On			SL Lift Delta	High Lift Delta
		Bolt-on Edges	Teeth & Segments	Teeth	Bolt-on Edges	Teeth & Segments	Teeth		
Capacity — rated	m <sup>3</sup>	3.6	3.6	3.5	3.3	3.3	3.1	—	—
	yd <sup>3</sup>	4.7	4.7	4.6	4.3	4.3	4.1	—	—
Capacity — struck	m <sup>3</sup>	3.2	3.2	3.0	2.8	2.8	2.7	—	—
	yd <sup>3</sup>	4.2	4.2	3.9	3.7	3.7	3.5	—	—
Width	mm	2946	2946	2946	2927	2994	2994	—	—
	ft/in	9'8"	9'8"	9'8"	9'7"	9'9"	9'9"	—	—
Dump clearance at maximum lift and 45° discharge	mm	2966	2859	2859	3025	2913	2913	-190	+305
	ft/in	9'8"	9'4"	9'4"	9'11"	9'6"	9'6"	+4"	+1'0"
Reach at maximum lift and 45° discharge	mm	1288	1383	1383	1108	1197	1197	+82	+118
	ft/in	4'2"	4'6"	4'6"	3'7"	3'11"	3'11"	+3"	+4"
Reach at level lift arm and bucket level	mm	2791	2933	2933	2638	2780	2780	-68	+306
	ft/in	9'1"	9'7"	9'7"	8'7"	9'1"	9'1"	+2"	+1'0"
Digging depth	mm	92	97	62	92	97	62	+0	+21
	in	3.6"	3.8"	2.4"	3.6"	3.8"	2.4"	+0	+1"
Overall length	mm	8385	8539	8539	8232	8386	8386	-127	+374
	ft/in	27'6"	28'0"	28'0"	27'0"	27'6"	27'6"	+4"	+1'2"
Overall height with bucket at maximum lift	mm	5613	5613	5613	5626	5626	5626	-190	+305
	ft/in	18'4"	18'4"	18'4"	18'5"	18'5"	18'5"	+7"	+1'0"
Loader clearance circle with bucket at carry position	mm	13 545	13 644	13 644	13 439	13 595	13 595	-119	+269
	ft/in	44'5"	44'9"	44'9"	44'1"	44'7"	44'7"	+4"	+10"
Static tipping load — straight*	kg	13 024	13 083	13 065	13 254	13 140	13 434	+744	-2603
	lb	28,704	28,834	28,796	29,212	28,961	29,608	+1641	-5737
Static tipping load — articulated* maximum 40° turn	kg	11 140	11 174	11 182	11 324	11 210	11 484	+657	-2297
	lb	24,552	24,627	24,645	24,958	24,706	25,310	+1405	-5062
Breakout force**	kN	142	142	154	159	158	173	-1	-9
	lb	32,000	31,850	34,571	35,624	35,461	38,814	-210	-2042
Operating weight*	kg	18 837	18 944	18 787	18 871	18 978	18 821	+8	+544
	lb	41,516	41,752	41,406	41,591	41,827	41,481	+8	+1199

\*Static tipping loads and operating weight are based on the following loader configuration: L3 Michelin XHA tires, air conditioning, ride control, power train guard, full fluids, fuel tank, coolant, lubricants and operator.

Static tipping loads conform to the international standard as defined in ISO 14397-1 (SEPT2007).

\*\*Measured 100 mm (4") behind tip of cutting edge with bucket hinge pin as pivot point in accordance with SAE J732 (APR2007).

**NOTE:** Specifications and ratings conform to all applicable standards recommended by the Society of Automotive Engineers, including SAE Standard J732 (APR2007) which governs loader ratings.

	Width over tires		Change in vertical dimensions		Change in operating weight		Change in static tipping load	
	mm	in	mm	in	kg	lb	kg	lb
23.5R25 VSW BS L2, Radial	2862	113	+ 6	+0	+ 20	+ 44	+ 14	+ 31
23.5R25 VUT D2A BS L2, Radial	2866	113	+10	+0	- 41	- 90	- 29	- 64
23.5R25 XTLA MX L2, Radial	2801	110	+ 7	+0	-112	- 247	- 79	- 174
23.5R25 VMT BS L3, Radial	2851	112	+ 3	+0	+124	+ 273	+ 88	+ 194
23.5R25 XHA MX L3, Radial	2784	110	+ 0	+0	+ 0	+ 0	+ 0	+ 0
23.5R25 XMINE MX L5, Radial	2807	111	+26	+1	+872	+1923	+619	+1365
750/65R25 XLD MX L3, Radial	2879	113	+ 7	+0	+460	+1014	+326	+ 719
23.5-25 SGL FS L2, Bias	2834	112	+14	+1	-472	-1041	-335	- 739

Bucket Type	Edge Type	Material Handling — Pin On						SL Lift Delta	High Lift Delta
		Bolt-on Edges	Teeth & Segments	Teeth	Bolt-on Edges	Teeth & Segments	Teeth		
Capacity — rated	m³	3.5	3.5	3.3	3.8	3.8	3.6	—	—
	yd³	4.6	4.6	4.3	5.0	5.0	4.7	—	—
Capacity — struck	m³	3.0	3.0	2.8	3.3	3.3	3.1	—	—
	yd³	3.9	3.9	3.7	4.3	4.3	4.1	—	—
Width	mm	2927	2994	2994	2927	2994	2994	—	—
	ft/in	9'7"	9'9"	9'9"	9'7"	9'9"	9'9"	—	—
Dump clearance at maximum lift and 45° discharge	mm	2990	2878	2878	2937	2825	2825	-190	+305
	ft/in	9'9"	9'5"	9'5"	9'7"	9'3"	9'3"	+4"	+1'0"
Reach at maximum lift and 45° discharge	mm	1144	1232	1232	1197	1285	1285	+82	+118
	ft/in	3'9"	4'0"	4'0"	3'11"	4'2"	4'2"	+3"	+4"
Reach at level lift arm and bucket level	mm	2688	2830	2830	2763	2905	2905	-68	+306
	ft/in	8'9"	9'3"	9'3"	9'0"	9'6"	9'6"	+2"	+1'0"
Digging depth	mm	92	97	62	92	97	62	+0	+21
	in	3.6"	3.8"	2.4"	3.6"	3.8"	2.4"	+0	+1"
Overall length	mm	8282	8436	8436	8357	8511	8511	-127	+374
	ft/in	27'2"	27'8"	27'8"	27'5"	27'11"	27'11"	+4"	+1'2"
Overall height with bucket at maximum lift	mm	5672	5672	5672	5741	5741	5741	-190	+305
	ft/in	18'7"	18'7"	18'7"	18'10"	18'10"	18'10"	+7"	+1'0"
Loader clearance circle with bucket at carry position	mm	13 467	13 624	13 624	13 511	13 669	13 669	-119	+269
	ft/in	44'2"	44'8"	44'8"	44'3"	44'10"	44'10"	+4"	+10"
Static tipping load — straight*	kg	13 148	13 034	13 325	12 993	12 878	13 165	+744	-2603
	lb	28,979	28,727	29,368	28,636	28,384	29,015	+1641	-5737
Static tipping load — articulated* maximum 40° turn	kg	11 225	11 110	11 382	11 080	10 965	11 233	+657	-2297
	lb	24,740	24,487	25,086	24,419	24,167	24,756	+1405	-5062
Breakout force**	kN	152	151	165	143	142	154	-1	-9
	lb	34,086	33,923	37,010	32,028	31,867	34,611	-210	-2042
Operating weight*	kg	18 913	19 020	18 863	18 978	19 085	18 928	+8	+544
	lb	41,684	41,920	41,574	41,827	42,063	41,717	+8	+1199

\*Static tipping loads and operating weight are based on the following loader configuration: L3 Michelin XHA tires, air conditioning, ride control, power train guard, full fluids, fuel tank, coolant, lubricants and operator.

Static tipping loads conform to the international standard as defined in ISO 14397-1 (SEPT2007).

\*\*Measured 100 mm (4") behind tip of cutting edge with bucket hinge pin as pivot point in accordance with SAE J732 (APR2007).

**NOTE:** Specifications and ratings conform to all applicable standards recommended by the Society of Automotive Engineers, including SAE Standard J732 (APR2007) which governs loader ratings.

	Width over tires		Change in vertical dimensions		Change in operating weight		Change in static tipping load	
	mm	in	mm	in	kg	lb	kg	lb
23.5R25 VSW BS L2, Radial	2862	113	+ 6	+0	+ 20	+ 44	+ 14	+ 31
23.5R25 VUT D2A BS L2, Radial	2866	113	+10	+0	- 41	- 90	- 29	- 64
23.5R25 XTLA MX L2, Radial	2801	110	+ 7	+0	-112	- 247	- 79	- 174
23.5R25 VMT BS L3, Radial	2851	112	+ 3	+0	+124	+ 273	+ 88	+ 194
23.5R25 XHA MX L3, Radial	2784	110	+ 0	+0	+ 0	+ 0	+ 0	+ 0
23.5R25 XMINE MX L5, Radial	2807	111	+26	+1	+872	+1923	+619	+1365
750/65R25 XLD MX L3, Radial	2879	113	+ 7	+0	+460	+1014	+326	+ 719
23.5-25 SGGL FS L2, Bias	2834	112	+14	+1	-472	-1041	-335	- 739



Bucket Type	General Purpose — Fusion QC							SL Lift Delta	High Lift Delta
	Edge Type	Bolt-on Edges	Teeth & Segments	Teeth	Bolt-on Edges	Teeth & Segments	Teeth		
Capacity — rated	m <sup>3</sup> yd <sup>3</sup>	3.1 4.1	3.1 4.1	2.9 3.8	3.4 4.4	3.4 4.4	3.3 4.3	— —	— —
Capacity — struck	m <sup>3</sup> yd <sup>3</sup>	2.3 3.0	2.3 3.0	2.1 2.8	2.6 3.4	2.6 3.4	2.4 3.2	— —	— —
Width	mm ft/in	2927 9'7"	2994 9'9"	2994 9'9"	2927 9'7"	2994 9'9"	2994 9'9"	— —	— —
Dump clearance at maximum lift and 45° discharge	mm ft/in	3085 10'1"	2984 9'9"	2984 9'9"	3002 9'10"	2898 9'6"	2898 9'6"	-190 +4"	+305 +1'0"
Reach at maximum lift and 45° discharge	mm ft/in	1255 4'1"	1355 4'5"	1355 4'5"	1310 4'3"	1408 4'7"	1408 4'7"	+82 +3"	+118 +4"
Reach at level lift arm and bucket level	mm ft/in	2672 8'9"	2814 9'2"	2814 9'2"	2774 9'1"	2916 9'6"	2916 9'6"	-68 +2"	+306 +1'0"
Digging depth	mm in	100 3.9"	100 3.9"	70 2.7"	100 3.9"	100 3.9"	70 2.7"	+0 +0	+21 +1"
Overall length	mm ft/in	8272 27'1"	8426 27'7"	8426 27'7"	8374 27'5"	8528 27'11"	8528 27'11"	-127 +4"	+374 +1'2"
Overall height with bucket at maximum lift	mm ft/in	5557 18'2"	5557 18'2"	5557 18'2"	5654 18'6"	5654 18'6"	5654 18'6"	-190 +7"	+305 +1'0"
Loader clearance circle with bucket at carry position	mm ft/in	13 457 44'1"	13 615 44'8"	13 615 44'8"	13 517 44'4"	13 677 44'10"	13 677 44'10"	-119 +4"	+269 +10"
Static tipping load — straight*	kg lb	12 865 28,355	12 727 28,049	13 063 28,792	12 672 27,929	12 532 27,620	12 861 28,345	+744 +1641	-2603 -5737
Static tipping load — articulated* maximum 40° turn	kg lb	10 940 24,113	10 802 23,807	11 119 24,506	10 759 23,713	10 619 23,404	10 929 24,088	+657 +1405	-2297 -5062
Breakout force**	kN lb	155 34,740	153 34,478	168 37,835	142 31,916	141 31,656	154 34,544	-1 -210	-9 -2042
Operating weight*	kg lb	19 306 42,550	19 414 42,788	19 257 42,442	19 394 42,744	19 502 42,982	19 345 42,636	+8 +18	+544 +1199

\*Static tipping loads and operating weight are based on the following loader configuration: L3 Michelin XHA tires, air conditioning, ride control, power train guard, full fluids, fuel tank, coolant, lubricants and operator.

Static tipping loads conform to the international standard as defined in ISO 14397-1 (SEPT2007).

\*\*Measured 100 mm (4") behind tip of cutting edge with bucket hinge pin as pivot point in accordance with SAE J732 (APR2007).

**NOTE:** Specifications and ratings conform to all applicable standards recommended by the Society of Automotive Engineers, including SAE Standard J732 (APR2007) which governs loader ratings.

	Width over tires		Change in vertical dimensions		Change in operating weight		Change in static tipping load	
	mm	in	mm	in	kg	lb	kg	lb
23.5R25 VSW BS L2, Radial	2862	113	+ 6	+0	+ 20	+ 44	+ 14	+ 31
23.5R25 VUT D2A BS L2, Radial	2866	113	+10	+0	- 41	- 90	- 29	- 64
23.5R25 XTLA MX L2, Radial	2801	110	+ 7	+0	-112	- 247	- 79	- 174
23.5R25 VMT BS L3, Radial	2851	112	+ 3	+0	+124	+ 273	+ 88	+ 194
23.5R25 XHA MX L3, Radial	2784	110	+ 0	+0	+ 0	+ 0	+ 0	+ 0
23.5R25 XMINE MX L5, Radial	2807	111	+26	+1	+872	+1923	+619	+1365
750/65R25 XLD MX L3, Radial	2879	113	+ 7	+0	+460	+1014	+326	+ 719
23.5-25 SGL FS L2, Bias	2834	112	+14	+1	-472	-1041	-335	- 739

Bucket Type		General Purpose — Fusion QC			Material Handling — Fusion QC			SL Lift Delta	High Lift Delta
		Bolt-on Edges	Teeth & Segments	Teeth	Bolt-on Edges	Teeth & Segments	Teeth		
Edge Type									
Capacity — rated	m <sup>3</sup> yd <sup>3</sup>	3.8 5.0	3.8 5.0	3.6 4.7	3.4 4.4	3.4 4.4	3.3 4.3	— —	— —
Capacity — struck	m <sup>3</sup> yd <sup>3</sup>	2.9 3.8	2.9 3.8	2.7 3.6	2.7 3.5	2.7 3.5	2.5 3.3	— —	— —
Width	mm ft/in	2927 9'7"	2994 9'9"	2994 9'9"	2927 9'7"	2994 9'9"	2994 9'9"	— —	— —
Dump clearance at maximum lift and 45° discharge	mm ft/in	2923 9'7"	2819 9'2"	2819 9'2"	2984 9'9"	2872 9'5"	2872 9'5"	-190 +4"	+305 +1'0"
Reach at maximum lift and 45° discharge	mm ft/in	1368 4'5"	1465 4'9"	1465 4'9"	1138 3'8"	1227 4'0"	1227 4'0"	+82 +3"	+118 +4"
Reach at level lift arm and bucket level	mm ft/in	2874 9'5"	3016 9'10"	3016 9'10"	2688 8'9"	2830 9'3"	2830 9'3"	-68 +2"	+306 +1'0"
Digging depth	mm in	100 3.9"	100 3.9"	70 2.7"	100 3.9"	100 3.9"	70 2.7"	+0 +0	+21 +1"
Overall length	mm ft/in	8474 27'9"	8628 28'3"	8628 28'3"	8288 27'2"	8442 27'8"	8442 27'8"	-127 +4"	+374 +1'2"
Overall height with bucket at maximum lift	mm ft/in	5750 18'10"	5750 18'10"	5750 18'10"	5650 18'6"	5650 18'6"	5650 18'6"	-190 +7"	+305 +1'0"
Loader clearance circle with bucket at carry position	mm ft/in	13 578 44'6"	13 738 45'0"	13 738 45'0"	13 466 44'2"	13 625 44'8"	13 625 44'8"	-119 +4"	+269 +10"
Static tipping load — straight*	kg lb	12 479 27,503	12 337 27,191	12 662 27,907	12 813 28,240	12 674 27,934	13 004 28,662	+744 +1641	-2603 -5737
Static tipping load — articulated* maximum 40° turn	kg lb	10 578 23,314	10 437 23,002	10 744 23,679	10 889 24,000	10 750 23,694	11 062 24,380	+657 +1405	-2297 -5062
Breakout force**	kN lb	131 29,521	130 29,263	141 31,785	152 34,214	151 33,952	166 37,223	-1 -210	-9 -2042
Operating weight*	kg lb	19 477 42,928	19 585 43,166	19 428 42,820	19 349 42,645	19 457 42,883	19 300 42,537	+8 +18	+544 +1199

\*Static tipping loads and operating weight are based on the following loader configuration: L3 Michelin XHA tires, air conditioning, ride control, power train guard, full fluids, fuel tank, coolant, lubricants and operator.

Static tipping loads conform to the international standard as defined in ISO 14397-1 (SEPT2007).

\*\*Measured 100 mm (4") behind tip of cutting edge with bucket hinge pin as pivot point in accordance with SAE J732 (APR2007).

**NOTE:** Specifications and ratings conform to all applicable standards recommended by the Society of Automotive Engineers, including SAE Standard J732 (APR2007) which governs loader ratings.

	Width over tires		Change in vertical dimensions		Change in operating weight		Change in static tipping load	
	mm	in	mm	in	kg	lb	kg	lb
23.5R25 VSW BS L2, Radial	2862	113	+ 6	+0	+ 20	+ 44	+ 14	+ 31
23.5R25 VUT D2A BS L2, Radial	2866	113	+10	+0	- 41	- 90	- 29	- 64
23.5R25 XTLA MX L2, Radial	2801	110	+ 7	+0	-112	- 247	- 79	- 174
23.5R25 VMT BS L3, Radial	2851	112	+ 3	+0	+124	+ 273	+ 88	+ 194
23.5R25 XHA MX L3, Radial	2784	110	+ 0	+0	+ 0	+ 0	+ 0	+ 0
23.5R25 XMINE MX L5, Radial	2807	111	+26	+1	+872	+1923	+619	+1365
750/65R25 XLD MX L3, Radial	2879	113	+ 7	+0	+460	+1014	+326	+ 719
23.5-25 SGGL FS L2, Bias	2834	112	+14	+1	-472	-1041	-335	- 739

Bucket Type		Material Handling — Fusion QC			Rock — Pin On		Waste — Pin On	SL Lift Delta	High Lift Delta
		Bolt-on Edges	Teeth & Segments	Teeth	Bolt-on Edges	Bottom Strap Teeth	Bolt-on Edges		
Capacity — rated	m <sup>3</sup>	3.8	3.8	3.6	3.1	3.1	5.2	—	—
	yd <sup>3</sup>	5.0	5.0	4.7	4.1	4.1	6.7	—	—
Capacity — struck	m <sup>3</sup>	3.0	3.0	2.8	2.7	2.7	—	—	—
	yd <sup>3</sup>	3.9	3.9	3.7	3.6	3.5	—	—	—
Width	mm	2927	2994	2994	2984	2969	3073	—	—
	ft/in	9'7"	9'9"	9'9"	9'9"	9'8"	10'1"	—	—
Dump clearance at maximum lift and 45° discharge	mm	2918	2806	2806	2996	2835	2905	-190	+305
	ft/in	9'6"	9'2"	9'2"	9'9"	9'3"	9'6"	+4"	+1'0"
Reach at maximum lift and 45° discharge	mm	1204	1293	1293	1290	1416	1228	+82	+118
	ft/in	3'11"	4'2"	4'2"	4'2"	4'7"	4'0"	+3"	+4"
Reach at level lift arm and bucket level	mm	2782	2924	2924	2768	2969	2807	-68	+306
	ft/in	9'1"	9'7"	9'7"	9'0"	9'8"	9'2"	+2"	+1'0"
Digging depth	mm	100	100	70	92	62	92	+0	+21
	in	3.9"	3.9"	2.7"	3.6"	2.4"	3.6"	+0	+1"
Overall length	mm	8382	8536	8536	8362	8593	8401	-127	+374
	ft/in	27'5"	28'0"	28'0"	27'5"	28'2"	27'6"	+4"	+1'2"
Overall height with bucket at maximum lift	mm	5741	5741	5741	5662	5662	6195	-190	+305
	ft/in	18'10"	18'10"	18'10"	18'6"	18'6"	20'3"	+7"	+1'0"
Loader clearance circle with bucket at carry position	mm	13 522	13 681	13 681	13 565	13 705	13 669	-119	+269
	ft/in	44'4"	44'10"	44'10"	44'6"	44'11"	44'10"	+4"	+10"
Static tipping load — straight*	kg	12 626	12 485	12 812	12 581	12 731	13 079	+744	-2603
	lb	27,827	27,518	28,238	27,727	28,059	28,827	+1641	-5737
Static tipping load — articulated* maximum 40° turn	kg	10 714	10 574	10 883	10 651	10 796	11 057	+657	-2297
	lb	23,614	23,305	23,985	23,474	23,795	24,370	+1405	-5062
Breakout force**	kN	141	140	152	141	148	136	-1	-9
	lb	31,655	31,396	34,246	31,583	33,168	30,495	-210	-2042
Operating weight*	kg	19 431	19 539	19 382	19 500	19 417	19 606	+8	+544
	lb	42,825	43,064	42,717	42,978	42,795	43,211	+18	+1199

\*Static tipping loads and operating weight are based on the following loader configuration: L3 Michelin XHA tires, air conditioning, ride control, power train guard, full fluids, fuel tank, coolant, lubricants and operator.

Static tipping loads conform to the international standard as defined in ISO 14397-1 (SEPT2007).

\*\*Measured 100 mm (4") behind tip of cutting edge with bucket hinge pin as pivot point in accordance with SAE J732 (APR2007).

**NOTE:** Specifications and ratings conform to all applicable standards recommended by the Society of Automotive Engineers, including SAE Standard J732 (APR2007) which governs loader ratings.

	Width over tires		Change in vertical dimensions		Change in operating weight		Change in static tipping load	
	mm	in	mm	in	kg	lb	kg	lb
	23.5R25 VSW BS L2, Radial	2862	113	+ 6	+0	+ 20	+ 44	+ 14
23.5R25 VUT D2A BS L2, Radial	2866	113	+10	+0	- 41	- 90	- 29	- 64
23.5R25 XTLA MX L2, Radial	2801	110	+ 7	+0	-112	- 247	- 79	- 174
23.5R25 VMT BS L3, Radial	2851	112	+ 3	+0	+124	+ 273	+ 88	+ 194
23.5R25 XHA MX L3, Radial	2784	110	+ 0	+0	+ 0	+ 0	+ 0	+ 0
23.5R25 XMINE MX L5, Radial	2807	111	+26	+1	+872	+1923	+619	+1365
750/65R25 XLD MX L3, Radial	2879	113	+ 7	+0	+460	+1014	+326	+ 719
23.5-25 SGGL FS L2, Bias	2834	112	+14	+1	-472	-1041	-335	- 739

Bucket Type		General Purpose — Fusion QC								
		Bolt-on Edges	Teeth & Segments	Teeth	Bolt-on Edges	Teeth & Segments	Teeth	Bolt-on Edges	Teeth & Segments	Teeth
Capacity — rated	m³	3.1	3.1	2.9	3.4	3.4	3.3	3.8	3.8	3.6
	yd³	4.1	4.1	3.8	4.5	4.5	4.3	5.0	5.0	4.7
Capacity — struck	m³	2.7	2.7	2.5	3.0	3.0	2.9	3.4	3.4	3.2
	yd³	3.5	3.5	3.3	4.0	4.0	3.7	4.4	4.4	4.2
Width	mm	2927	2994	2994	2927	2994	2994	2927	2994	2994
	ft/in	9'7"	9'9"	9'9"	9'7"	9'9"	9'9"	9'7"	9'9"	9'9"
Dump clearance at maximum lift and 45° discharge	mm	2868	2750	2750	2793	2675	2675	2724	2604	2604
	ft/in	9'4"	9'0"	9'0"	9'1"	8'9"	8'9"	8'11"	8'6"	8'6"
Reach at maximum lift and 45° discharge	mm	1355	1467	1467	1414	1524	1524	1473	1582	1582
	ft/in	4'5"	4'9"	4'9"	4'7"	4'11"	4'11"	4'9"	5'2"	5'2"
Reach at level lift arm and bucket level	mm	2815	2976	2976	2912	3073	3073	3005	3166	3166
	ft/in	9'2"	9'9"	9'9"	9'6"	10'0"	10'0"	9'10"	10'4"	10'4"
Digging depth	mm	75	75	45	75	75	45	75	75	45
	in	2.97	2.97	1.79	2.97	2.97	1.79	2.97	2.97	1.79
Overall length	mm	8453	8626	8626	8550	8723	8723	8643	8816	8816
	ft/in	27'8"	28'3"	28'3"	28'0"	28'7"	28'7"	28'4"	28'11"	28'11"
Overall height with bucket at maximum lift	mm	5561	5561	5561	5661	5661	5661	5758	5758	5758
	ft/in	18'2"	18'2"	18'2"	18'6"	18'6"	18'6"	18'10"	18'10"	18'10"
Loader clearance circle with bucket at carry position	mm	13 523	13 682	13 682	13 574	13 735	13 735	13 625	13 786	13 786
	ft/in	44'4"	44'10"	44'10"	44'6"	45'0"	45'0"	44'8"	45'2"	45'2"
Static tipping load — straight*	kg	12 581	12 445	12 762	12 400	12 263	12 578	12 225	12 086	12 399
	lb	27,728	27,429	28,128	27,330	27,028	27,722	26,943	26,638	27,328
Static tipping load — articulated* maximum 40° turn	kg	10 693	10 557	10 856	10 523	10 385	10 683	10 357	10 218	10 515
	lb	23,567	23,267	23,927	23,192	22,889	23,546	22,827	22,521	23,175
Breakout force**	kN	151	150	163	140	139	151	131	130	140
	lb	33,825	33,619	36,591	31,415	31,207	33,821	29,365	29,156	31,489
Operating weight*	kg	19 667	19 775	19 618	19 753	19 861	19 704	19 839	19 947	19 790
	lb	43,346	43,584	43,238	43,536	43,774	43,428	43,724	43,962	43,616

\*Static tipping loads and operating weight are based on the following loader configuration: L3 Michelin XHA tires, air conditioning, ride control, power train guard, full fluids, fuel tank, coolant, lubricants and operator.

Static tipping loads conform to the international standard as defined in ISO 14397-1 (SEPT2007).

\*\*Measured 100 mm (4") behind tip of cutting edge with bucket hinge pin as pivot point in accordance with SAE J732 (APR2007).

**NOTE:** Specifications and ratings conform to all applicable standards recommended by the Society of Automotive Engineers, including SAE Standard J732 (APR2007) which governs loader ratings.

	Width over tires		Change in vertical dimensions		Change in operating weight		Change in static tipping load	
	mm	in	mm	in	kg	lb	kg	lb
23.5R25 VSW BS L2, Radial	2862	113	+ 6	+0	+ 20	+ 44	+ 14	+ 31
23.5R25 VUT D2A BS L2, Radial	2866	113	+10	+0	- 41	- 90	- 29	- 64
23.5R25 XTLA MX L2, Radial	2801	110	+ 7	+0	-112	- 247	- 79	- 174
23.5R25 VMT BS L3, Radial	2851	112	+ 3	+0	+124	+ 273	+ 88	+ 194
23.5R25 XHA MX L3, Radial	2784	110	+ 0	+0	+ 0	+ 0	+ 0	+ 0
23.5R25 XMINE MX L5, Radial	2807	111	+26	+1	+872	+1923	+619	+1365
750/65R25 XLD MX L3, Radial	2879	113	+ 7	+0	+460	+1014	+326	+ 719
23.5-25 SGGL FS L2, Bias	2834	112	+14	+1	-472	-1041	-335	- 739

Bucket Type		Material Handling — Fusion QC					
		Bolt-on Edges	Teeth & Segments	Teeth	Bolt-on Edges	Teeth & Segments	Teeth
Edge Type							
Capacity — rated	m <sup>3</sup>	3.5	3.5	3.3	3.8	3.8	3.6
	yd <sup>3</sup>	4.6	4.6	4.3	5.0	5.0	4.7
Capacity — struck	m <sup>3</sup>	2.9	2.9	2.7	3.3	3.3	3.1
	yd <sup>3</sup>	3.9	3.9	3.6	4.3	4.3	4.0
Width	mm	2927	2994	2994	2927	2994	2994
	ft/in	9'7"	9'9"	9'9"	9'7"	9'9"	9'9"
Dump clearance at maximum lift and 45° discharge	mm	2825	2700	2700	2769	2644	2644
	ft/in	9'3"	8'10"	8'10"	9'1"	8'8"	8'8"
Reach at maximum lift and 45° discharge	mm	1236	1338	1338	1292	1394	1394
	ft/in	4'0"	4'4"	4'4"	4'2"	4'6"	4'6"
Reach at level lift arm and bucket level	mm	2784	2945	2945	2863	3024	3024
	ft/in	9'1"	9'7"	9'7"	9'4"	9'11"	9'11"
Digging depth	mm	75	75	45	75	75	45
	in	2.97	2.97	1.79	2.97	2.97	1.79
Overall length	mm	8422	8595	8595	8501	8674	8674
	ft/in	27'7"	28'2"	28'2"	27'10"	28'5"	28'5"
Overall height with bucket at maximum lift	mm	5628	5628	5628	5721	5721	5721
	ft/in	18'5"	18'5"	18'5"	18'9"	18'9"	18'9"
Loader clearance circle with bucket at carry position	mm	13 506	13 666	13 666	13 548	13 708	13 708
	ft/in	44'3"	44'10"	44'10"	44'5"	44'11"	44'11"
Static tipping load — straight*	kg	13 170	13 032	13 358	13 073	12 933	13 259
	lb	29,028	28,722	29,441	28,814	28,504	29,223
Static tipping load — articulated* maximum 40° turn	kg	11 227	11 088	11 397	11 133	10 993	11 301
	lb	24,745	24,439	25,119	24,538	24,228	24,908
Breakout force**	kN	155	155	168	146	145	158
	lb	34,922	34,717	37,841	32,863	32,657	35,463
Operating weight*	kg	19 458	19 566	19 409	19 516	19 624	19 467
	lb	42,885	43,123	42,777	43,014	43,252	42,906

\*Static tipping loads and operating weight are based on the following loader configuration: L3 Michelin XHA tires, air conditioning, ride control, power train guard, full fluids, fuel tank, coolant, lubricants and operator.

Static tipping loads conform to the international standard as defined in ISO 14397-1 (SEPT2007).

\*\*Measured 100 mm (4") behind tip of cutting edge with bucket hinge pin as pivot point in accordance with SAE J732 (APR2007).

**NOTE:** Specifications and ratings conform to all applicable standards recommended by the Society of Automotive Engineers, including SAE Standard J732 (APR2007) which governs loader ratings.

	Width over tires		Change in vertical dimensions		Change in operating weight		Change in static tipping load	
	mm	in	mm	in	kg	lb	kg	lb
23.5R25 VSW BS L2, Radial	2862	113	+ 6	+0	+ 20	+ 44	+ 14	+ 31
23.5R25 VUT D2A BS L2, Radial	2866	113	+10	+0	- 41	- 90	- 29	- 64
23.5R25 XTLA MX L2, Radial	2801	110	+ 7	+0	-112	- 247	- 79	- 174
23.5R25 VMT BS L3, Radial	2851	112	+ 3	+0	+124	+ 273	+ 88	+ 194
23.5R25 XHA MX L3, Radial	2784	110	+ 0	+0	+ 0	+ 0	+ 0	+ 0
23.5R25 XMINE MX L5, Radial	2807	111	+26	+1	+872	+1923	+619	+1365
750/65R25 XLD MX L3, Radial	2879	113	+ 7	+0	+460	+1014	+326	+ 719
23.5-25 SGGL FS L2, Bias	2834	112	+14	+1	-472	-1041	-335	- 739

Bucket Type	General Purpose — Pin On									High Lift Delta	
		Bolt-on Edges	Teeth & Seg-ments	Teeth	Bolt-on Edges	Teeth & Seg-ments	Teeth	Bolt-on Edges	Teeth & Seg-ments		Teeth
Edge Type											
Capacity — rated	m <sup>3</sup> yd <sup>3</sup>	3.6 4.7	3.6 4.7	3.5 4.6	3.8 5.0	3.8 5.0	3.6 4.7	4.0 5.2	4.0 5.2	3.8 5.0	— —
Capacity — struck	m <sup>3</sup> yd <sup>3</sup>	3.1 4.1	3.1 4.1	3.0 3.9	3.3 4.3	3.3 4.3	3.1 4.1	3.4 4.5	3.4 4.5	3.3 4.3	— —
Width	mm ft/in	3059 10'0"	3145 10'3"	3145 10'3"	3059 10'0"	3145 10'3"	3145 10'3"	3059 10'0"	3145 10'3"	3145 10'3"	— —
Dump clearance at maximum lift and 45° discharge	mm ft/in	3134 10'3"	2984 9'9"	2984 9'9"	3099 10'2"	2948 9'8"	2948 9'8"	3066 10'0"	2914 9'6"	2914 9'6"	+558 +1'10"
Reach at maximum lift and 45° discharge	mm ft/in	1282 4'2"	1424 4'8"	1424 4'8"	1305 4'3"	1446 4'8"	1446 4'8"	1329 4'4"	1469 4'9"	1469 4'9"	-25 -1.0"
Reach at level lift arm and bucket level	mm ft/in	2652 8'8"	2857 9'4"	2857 9'4"	2695 8'10"	2900 9'6"	2900 9'6"	2737 8'11"	2942 9'7"	2942 9'7"	+404 +1'4"
Digging depth	mm in	129 5	129 5	99 3.8	129 5	129 5	99 3.8	129 5	129 5	99 3.8	-25 -1.0
Overall length	mm ft/in	8595 28'2"	8820 28'11"	8820 28'11"	8638 28'4"	8863 29'0"	8863 29'0"	8680 28'5"	8905 29'2"	8905 29'2"	+715 +2'4"
Overall height with bucket at maximum lift	mm ft/in	5754 18'10"	5754 18'10"	5754 18'10"	5794 19'0"	5794 19'0"	5794 19'0"	5832 19'1"	5832 19'1"	5832 19'1"	+558 +1'10"
Loader clearance circle with bucket at carry position	mm ft/in	14 536 47'8"	14 739 48'4"	14 739 48'4"	14 558 47'9"	14 761 48'5"	14 761 48'5"	14 579 47'9"	14 783 48'6"	14 783 48'6"	+471 +1'6"
Static tipping load — straight*	kg lb	16 485 36,334	16 303 35,931	16 648 36,692	16 376 36,092	16 192 35,687	16 535 36,444	16 284 35,889	16 099 35,483	16 441 36,235	+403 +888
Static tipping load — articulated* maximum 37° turn	kg lb	14 491 31,937	14 308 31,534	14 635 32,256	14 386 31,707	14 202 31,302	14 528 32,021	14 299 31,515	14 115 31,109	14 439 31,824	+185 +408
Breakout force**	kN lb	201 45,267	200 44,885	215 48,406	194 43,630	193 43,249	207 46,546	188 42,168	186 41,790	200 44,888	-15 -3431
Operating weight*	kg lb	23 360 51,486	23 500 51,794	23 348 51,459	23 416 51,609	23 556 51,918	23 404 51,583	23 450 51,684	23 590 51,993	23 438 51,658	+1799 +3965

\*Static tipping loads and operating weight are based on the following loader configuration: L3 Michelin XHA tires, air conditioning, ride control, power train guard, full fluids, fuel tank, coolant, lubricants and operator.

Static tipping loads conform to the international standard as defined in ISO 14397-1 (SEPT2007).

\*\*Measured 100 mm (4") behind tip of cutting edge with bucket hinge pin as pivot point in accordance with SAE J732 (APR2007).

**NOTE:** Specifications and ratings conform to all applicable standards recommended by the Society of Automotive Engineers, including SAE Standard J732 (APR2007) which governs loader ratings.

	Width over tires		Change in vertical dimensions		Change in operating weight		Change in static tipping load	
	mm	in	mm	in	kg	lb	kg	lb
	26.5R25 GP2B GY L2, Radial	3012	119	+ 0	+0	- 48	- 106	- 36
26.5R25 VMT BS L3, Radial	3015	119	+ 0	+0	+ 82	+ 181	- 14	- 31
26.5R25 RT3B GY L3, Radial	3017	119	+ 0	+0	+ 10	+ 22	+ 7	+ 15
26.5R25 XHA MX L3, Radial	3017	119	+ 0	+0	+ 0	+ 0	+ 0	+ 0
26.5R25 VSDL BS L5, Radial	2956	116	+20	+1	+1248	+2752	+937	+2066
750/65R25 MX L3, Radial Low Profile	3076	121	+ 0	+0	- 228	- 503	- 21	- 47
26.5-25 20 PR SRG FS L3, Bias	2992	118	-24	-1	- 324	- 714	-461	-1017
26.5-25 20 PR SHRL GY L3, Bias	2974	117	+ 0	+0	+ 41	+ 90	-127	- 280
26.5-25 SRG DT FS LDL4, Bias	3002	118	+20	+1	+ 34	+ 75	+ 31	+ 68

Bucket Type		General Purpose — Pin On			Material Handling — Pin On						High Lift Delta
		Bolt-on Edges	Teeth & Seg-ments	Teeth	Bolt-on Edges	Teeth & Seg-ments	Teeth	Bolt-on Edges	Teeth & Seg-ments	Teeth	
Edge Type											
Capacity — rated	m <sup>3</sup> yd <sup>3</sup>	4.3 5.6	4.3 5.6	4.0 5.2	3.8 5.0	3.8 5.0	3.6 4.7	4.0 5.2	4.0 5.2	3.8 5.0	— —
Capacity — struck	m <sup>3</sup> yd <sup>3</sup>	3.6 4.7	3.6 4.7	3.4 4.5	3.2 4.2	3.2 4.2	3.1 4.0	3.5 4.5	3.5 4.5	3.3 4.3	— —
Width	mm ft/in	3220 10'6"	3306 10'10"	3306 10'10"	3220 10'6"	3306 10'10"	3306 10'10"	3220 10'6"	3306 10'10"	3306 10'10"	— —
Dump clearance at maximum lift and 45° discharge	mm ft/in	3066 10'0"	2914 9'6"	2914 9'6"	3063 10'0"	2900 9'6"	2900 9'6"	3020 9'10"	2857 9'4"	2857 9'4"	+558 +1'10"
Reach at maximum lift and 45° discharge	mm ft/in	1329 4'4"	1469 4'9"	1469 4'9"	1162 3'9"	1289 4'2"	1289 4'2"	1205 3'11"	1331 4'4"	1331 4'4"	-25 -1.0"
Reach at level lift arm and bucket level	mm ft/in	2737 8'11"	2942 9'7"	2942 9'7"	2642 8'8"	2847 9'4"	2847 9'4"	2702 8'10"	2907 9'6"	2907 9'6"	+404 +1'4"
Digging depth	mm in	129 5	129 5	99 3.8	129 5	129 5	99 3.8	129 5	129 5	99 3.8	-25 -1.0
Overall length	mm ft/in	8680 28'5"	8905 29'2"	8905 29'2"	8585 28'1"	8810 28'10"	8810 28'10"	8645 28'4"	8870 29'1"	8870 29'1"	+715 +2'4"
Overall height with bucket at maximum lift	mm ft/in	5832 19'1"	5832 19'1"	5832 19'1"	5727 18'9"	5727 18'9"	5727 18'9"	5783 18'11"	5783 18'11"	5783 18'11"	+558 +1'10"
Loader clearance circle with bucket at carry position	mm ft/in	14 727 48'3"	14 929 48'11"	14 929 48'11"	14 679 48'1"	14 880 48'9"	14 880 48'9"	14 709 48'3"	14 911 48'11"	14 911 48'11"	+471 +1'6"
Static tipping load — straight*	kg lb	16 290 35,902	16 077 35,433	16 457 36,271	16 260 35,838	16 052 35,378	16 430 36,211	16 110 35,506	15 900 35,044	16 276 35,872	+403 +888
Static tipping load — articulated* maximum 37° turn	kg lb	14 295 31,507	14 082 31,037	14 446 31,840	14 282 31,477	14 073 31,016	14 434 31,814	14 138 31,161	13 929 30,699	14 288 31,491	+185 +408
Breakout force**	kN lb	187 42,080	185 41,673	199 44,821	203 45,546	201 45,134	217 48,755	193 43,272	191 42,863	206 46,171	-15 -3431
Operating weight*	kg lb	23 526 51,852	23 693 52,220	23 502 51,799	23 451 51,686	23 618 52,054	23 427 51,633	23 522 51,843	23 689 52,211	23 498 51,790	+1799 +3965

\*Static tipping loads and operating weight are based on the following loader configuration: L3 Michelin XHA tires, air conditioning, ride control, power train guard, full fluids, fuel tank, coolant, lubricants and operator.

Static tipping loads conform to the international standard as defined in ISO 14397-1 (SEPT2007).

\*\*Measured 100 mm (4") behind tip of cutting edge with bucket hinge pin as pivot point in accordance with SAE J732 (APR2007).

**NOTE:** Specifications and ratings conform to all applicable standards recommended by the Society of Automotive Engineers, including SAE Standard J732 (APR2007) which governs loader ratings.

	Width over tires		Change in vertical dimensions		Change in operating weight		Change in static tipping load	
	mm	in	mm	in	kg	lb	kg	lb
	26.5R25 GP2B GY L2, Radial	3012	119	+ 0	+0	- 48	- 106	- 36
26.5R25 VMT BS L3, Radial	3015	119	+ 0	+0	+ 82	+ 181	- 14	- 31
26.5R25 RT3B GY L3, Radial	3017	119	+ 0	+0	+ 10	+ 22	+ 7	+ 15
26.5R25 XHA MX L3, Radial	3017	119	+ 0	+0	+ 0	+ 0	+ 0	+ 0
26.5R25 VSDL BS L5, Radial	2956	116	+20	+1	+1248	+2752	+937	+2066
750/65R25 MX L3, Radial Low Profile	3076	121	+ 0	+0	- 228	- 503	- 21	- 47
26.5-25 20 PR SRG FS L3, Bias	2992	118	-24	-1	- 324	- 714	-461	-1017
26.5-25 20 PR SHRL GY L3, Bias	2974	117	+ 0	+0	+ 41	+ 90	-127	- 280
26.5-25 SRG DT FS LDL4, Bias	3002	118	+20	+1	+ 34	+ 75	+ 31	+ 68

Bucket Type		General Purpose — Fusion QC						Material Handling — Fusion QC			High Lift Delta
		Bolt-on Edges	Teeth & Seg-ments	Teeth	Bolt-on Edges	Teeth & Seg-ments	Teeth	Bolt-on Edges	Teeth & Seg-ments	Teeth	
Edge Type											
Capacity — rated	m <sup>3</sup> yd <sup>3</sup>	3.8 5.0	3.8 5.0	3.6 4.7	4.2 5.5	4.2 5.5	4.0 5.2	4.2 5.5	4.2 5.5	4.0 5.2	— —
Capacity — struck	m <sup>3</sup> yd <sup>3</sup>	3.5 4.6	3.5 4.6	3.3 4.3	3.9 5.1	3.9 5.1	3.7 4.8	3.0 3.9	3.0 3.9	2.8 3.7	— —
Width	mm ft/in	3220 10'6"	3307 10'10"	3307 10'10"	3220 10'6"	3307 10'10"	3307 10'10"	3224 10'6"	3311 10'10"	3311 10'10"	— —
Dump clearance at maximum lift and 45° discharge	mm ft/in	3128 10'3"	2978 9'9"	2978 9'9"	3062 10'0"	2909 9'6"	2909 9'6"	2991 9'9"	2828 9'3"	2828 9'3"	+558 +1'10"
Reach at maximum lift and 45° discharge	mm ft/in	1287 4'2"	1429 4'8"	1429 4'8"	1334 4'4"	1473 4'9"	1473 4'9"	1246 4'1"	1373 4'6"	1373 4'6"	-25 -1.0"
Reach at level lift arm and bucket level	mm ft/in	2662 8'8"	2867 9'4"	2867 9'4"	2745 9'0"	2950 9'8"	2950 9'8"	2752 9'0"	2957 9'8"	2957 9'8"	+404 +1'4"
Digging depth	mm in	121 4.7	121 4.7	91 3.5	121 4.7	121 4.7	91 3.5	121 4.7	121 4.7	91 3.5	-25 -1.0
Overall length	mm ft/in	8599 28'2"	8824 28'11"	8824 28'11"	8682 28'5"	8907 29'2"	8907 29'2"	8689 28'6"	8914 29'2"	8914 29'2"	+715 +2'4"
Overall height with bucket at maximum lift	mm ft/in	5773 18'11"	5773 18'11"	5773 18'11"	5859 19'2"	5859 19'2"	5859 19'2"	5855 19'2"	5855 19'2"	5855 19'2"	+558 +1'10"
Loader clearance circle with bucket at carry position	mm ft/in	14 675 48'1"	14 880 48'9"	14 880 48'9"	14 717 48'3"	14 923 48'11"	14 923 48'11"	14 724 48'3"	14 931 48'11"	14 931 48'11"	+471 +1'6"
Static tipping load — straight*	kg lb	16 278 35,877	16 097 35,478	16 448 36,250	16 115 35,518	15 932 35,115	16 280 35,881	16 016 35,299	15 834 34,898	16 173 35,645	+403 +888
Static tipping load — articulated* maximum 37° turn	kg lb	14 265 31,439	14 083 31,039	14 417 31,776	14 109 31,095	13 925 30,692	14 257 31,422	14 022 30,905	13 840 30,503	14 164 31,217	+185 +408
Breakout force**	kN lb	200 44,862	198 44,490	214 47,975	186 41,871	185 41,503	198 44,587	185 41,633	184 41,266	197 44,319	-15 -3431
Operating weight*	kg lb	23 756 52,358	23 894 52,662	23 730 52,302	23 838 52,539	23 976 52,843	23 813 52,483	23 833 52,528	23 971 52,832	23 808 52,472	+1799 +3965

\*Static tipping loads and operating weight are based on the following loader configuration: L3 Michelin XHA tires, air conditioning, ride control, power train guard, full fluids, fuel tank, coolant, lubricants and operator.

Static tipping loads conform to the international standard as defined in ISO 14397-1 (SEPT2007).

\*\*Measured 100 mm (4") behind tip of cutting edge with bucket hinge pin as pivot point in accordance with SAE J732 (APR2007).

**NOTE:** Specifications and ratings conform to all applicable standards recommended by the Society of Automotive Engineers, including SAE Standard J732 (APR2007) which governs loader ratings.

	Width over tires		Change in vertical dimensions		Change in operating weight		Change in static tipping load	
	mm	in	mm	in	kg	lb	kg	lb
	26.5R25 GP2B GY L2, Radial	3012	119	+ 0	+0	- 48	- 106	- 36
26.5R25 VMT BS L3, Radial	3015	119	+ 0	+0	+ 82	+ 181	- 14	- 31
26.5R25 RT3B GY L3, Radial	3017	119	+ 0	+0	+ 10	+ 22	+ 7	+ 15
26.5R25 XHA MX L3, Radial	3017	119	+ 0	+0	+ 0	+ 0	+ 0	+ 0
26.5R25 VSDL BS L5, Radial	2956	116	+20	+1	+1248	+2752	+937	+2066
750/65R25 MX L3, Radial Low Profile	3076	121	+ 0	+0	- 228	- 503	- 21	- 47
26.5-25 20 PR SRG FS L3, Bias	2992	118	-24	-1	- 324	- 714	-461	-1017
26.5-25 20 PR SHRL GY L3, Bias	2974	117	+ 0	+0	+ 41	+ 90	-127	- 280
26.5-25 SRG DT FS LDL4, Bias	3002	118	+20	+1	+ 34	+ 75	+ 31	+ 68



Bucket Type		Rock — Pin On		Heavy Duty Rock — Pin On	Waste — Pin On	High Lift Delta
		Bolt-on Edges	Teeth & Segments	Teeth & Segments	Bolt-on Edges	
Capacity — rated	m <sup>3</sup>	3.5	3.5	3.5	6.4	—
	yd <sup>3</sup>	<b>4.6</b>	<b>4.6</b>	<b>4.6</b>	<b>8.3</b>	—
Capacity — struck	m <sup>3</sup>	3.0	3.0	3.0	5.4	—
	yd <sup>3</sup>	<b>3.9</b>	<b>3.9</b>	<b>3.9</b>	<b>7.1</b>	—
Width	mm	3283	3270	3270	3355	—
	ft/in	<b>10'9"</b>	<b>10'8"</b>	<b>10'8"</b>	<b>11'0"</b>	—
Dump clearance at maximum lift and 45° discharge	mm	3093	2945	2945	2969	+558
	ft/in	<b>10'1"</b>	<b>9'7"</b>	<b>9'7"</b>	<b>9'8"</b>	<b>+1'10"</b>
Reach at maximum lift and 45° discharge	mm	1458	1649	1649	1220	-25
	ft/in	<b>4'9"</b>	<b>5'4"</b>	<b>5'4"</b>	<b>4'0"</b>	<b>-1.0"</b>
Reach at level lift arm and bucket level	mm	2799	3041	3041	2750	+404
	ft/in	<b>9'2"</b>	<b>9'11"</b>	<b>9'11"</b>	<b>9'0"</b>	<b>+1'4"</b>
Digging depth	mm	134	139	139	154	-25
	in	<b>5.2</b>	<b>5.4</b>	<b>5.4</b>	<b>6</b>	<b>-1.0</b>
Overall length	mm	8746	8994	8994	8713	+715
	ft/in	<b>28'8"</b>	<b>29'6"</b>	<b>29'6"</b>	<b>28'7"</b>	<b>+2'4"</b>
Overall height with bucket at maximum lift	mm	5716	5716	6042	6480	+558
	ft/in	<b>18'9"</b>	<b>18'9"</b>	<b>19'9"</b>	<b>21'3"</b>	<b>+1'10"</b>
Loader clearance circle with bucket at carry position	mm	14 820	14 939	14 939	14 877	+471
	ft/in	<b>48'7"</b>	<b>49'0"</b>	<b>49'0"</b>	<b>48'9"</b>	<b>+1'6"</b>
Static tipping load — straight*	kg	16 258	16 123	15 999	16 627	+403
	lb	<b>35,832</b>	<b>35,535</b>	<b>35,261</b>	<b>36,646</b>	<b>+888</b>
Static tipping load — articulated* maximum 37° turn	kg	14 242	14 107	13 983	14 519	+185
	lb	<b>31,390</b>	<b>31,093</b>	<b>30,818</b>	<b>31,999</b>	<b>+408</b>
Breakout force**	kN	178	180	179	182	-15
	lb	<b>40,024</b>	<b>40,362</b>	<b>40,120</b>	<b>40,898</b>	<b>-3431</b>
Operating weight*	kg	23 695	23 797	23 957	24 065	+1799
	lb	<b>52,224</b>	<b>52,449</b>	<b>52,801</b>	<b>53,039</b>	<b>+3965</b>

\*Static tipping loads and operating weight are based on the following loader configuration: L3 Michelin XHA tires, air conditioning, ride control, power train guard, full fluids, fuel tank, coolant, lubricants and operator.

Static tipping loads conform to the international standard as defined in ISO 14397-1 (SEPT2007).

\*\*Measured 100 mm (4") behind tip of cutting edge with bucket hinge pin as pivot point in accordance with SAE J732 (APR2007).

**NOTE:** Specifications and ratings conform to all applicable standards recommended by the Society of Automotive Engineers, including SAE Standard J732 (APR2007) which governs loader ratings.

	Width over tires		Change in vertical dimensions		Change in operating weight		Change in static tipping load	
	mm	in	mm	in	kg	lb	kg	lb
26.5R25 GP2B GY L2, Radial	3012	<b>119</b>	+ 0	<b>+0</b>	- 48	- <b>106</b>	- 36	- <b>80</b>
26.5R25 VMT BS L3, Radial	3015	<b>119</b>	+ 0	<b>+0</b>	+ 82	+ <b>181</b>	- 14	- <b>31</b>
26.5R25 RT3B GY L3, Radial	3017	<b>119</b>	+ 0	<b>+0</b>	+ 10	+ <b>22</b>	+ 7	+ <b>15</b>
26.5R25 XHA MX L3, Radial	3017	<b>119</b>	+ 0	<b>+0</b>	+ 0	+ <b>0</b>	+ 0	+ <b>0</b>
26.5R25 VSDL BS L5, Radial	2956	<b>116</b>	+20	<b>+1</b>	+1248	+ <b>2752</b>	+937	+ <b>2066</b>
750/65R25 MX L3, Radial Low Profile	3076	<b>121</b>	+ 0	<b>+0</b>	- 228	- <b>503</b>	- 21	- <b>47</b>
26.5-25 20 PR SRG FS L3, Bias	2992	<b>118</b>	-24	<b>-1</b>	- 324	- <b>714</b>	-461	- <b>1017</b>
26.5-25 20 PR SHRL GY L3, Bias	2974	<b>117</b>	+ 0	<b>+0</b>	+ 41	+ <b>90</b>	-127	- <b>280</b>
26.5-25 SRG DT FS LDL4, Bias	3002	<b>118</b>	+20	<b>+1</b>	+ 34	+ <b>75</b>	+ 31	+ <b>68</b>

Bucket Type		Performance Series General Purpose — Pin On						High Lift Delta
		Bolt-on Edges	Teeth & Segments	Teeth	Bolt-on Edges	Teeth & Segments	Teeth	
Capacity — rated	m³	4.3	4.3	4.0	1.8	4.8	4.6	—
	yd³	5.6	5.6	5.3	6.3	6.3	6.0	—
Capacity — struck	m³	3.6	3.6	3.6	4.0	4.0	4.0	—
	yd³	4.7	4.7	4.7	5.3	5.3	5.3	—
Width	mm	3220	3220	3220	3200	3200	3200	—
	ft/in	10'6"	10'6"	10'6"	10'6"	10'6"	10'6"	—
Dump clearance at maximum lift and 45° discharge	mm	3220	3220	3220	3150	3150	3150	+336
	ft/in	10'6"	10'6"	10'6"	10'3"	10'3"	10'3"	+1'1"
Reach at maximum lift and 45° discharge	mm	1331	1331	1331	1390	1390	1390	+23
	ft/in	4'4"	4'4"	4'4"	4'6"	4'6"	4'6"	+0.9"
Reach at level lift arm and bucket level	mm	2953	2953	2953	3047	3047	3047	+274
	ft/in	9'8"	9'8"	9'8"	9'11"	9'11"	9'11"	+10.8"
Digging depth	mm	108	108	108	108	108	108	-5
	in	4.2	4.2	4.2	4.2	4.2	4.2	-0.2
Overall length	mm	9146	9146	9146	9240	9240	9240	+335
	ft/in	30'0"	30'0"	30'0"	30'2"	30'2"	30'2"	+1'1"
Overall height with bucket at maximum lift	mm	5931	5931	5931	6026	6026	6026	+336
	ft/in	19'5"	19'5"	19'5"	19'9"	19'9"	19'9"	+1'1"
Loader clearance circle with bucket at carry position	mm	14 924	14 924	14 924	14 976	14 976	14 976	+327
	ft/in	48'11"	48'11"	48'11"	49'1"	49'1"	49'1"	+1'1"
Static tipping load — straight*	kg	17 844	17 844	17 844	17 763	17 763	17 763	-1522
	lb	39,327	39,327	39,327	39,150	39,150	39,150	-3354
Static tipping load — articulated* maximum 37° turn	kg	15 522	15 522	15 522	15 446	15 446	15 446	-1370
	lb	34,211	34,211	34,211	34,043	34,043	34,043	-3020
Breakout force**	kN	226	226	226	211	211	211	-7
	lb	50,859	50,859	50,859	47,495	47,495	47,495	-1557
Operating weight*	kg	25 502	25 502	25 502	25 510	25 510	25 510	+84
	lb	56,207	56,207	56,207	56,223	56,223	56,223	+186

\*Static tipping loads and operating weight are based on the following loader configuration: L3 Michelin XHA tires, air conditioning, ride control, power train guard, full fluids, fuel tank, coolant, lubricants and operator.

Static tipping loads conform to the international standard as defined in ISO 14397-1 (SEPT2007).

\*\*Measured 100 mm (4") behind tip of cutting edge with bucket hinge pin as pivot point in accordance with SAE J732 (APR2007).

**NOTE:** Specifications and ratings conform to all applicable standards recommended by the Society of Automotive Engineers, including SAE Standard J732 (APR2007) which governs loader ratings.

	Width over tires		Change in vertical dimensions		Change in operating weight		Change in static tipping load	
	mm	in	mm	in	kg	lb	kg	lb
26.5R25 GP2B GY L2, Radial	3012	119	+ 0	+0	- 48	- 106	- 36	- 80
26.5R25 VMT BS L3, Radial	3015	119	+ 0	+0	+ 82	+ 181	- 14	- 31
26.5R25 RT3B GY L3, Radial	3017	119	+ 0	+0	+ 10	+ 22	+ 7	+ 15
26.5R25 XHA MX L3, Radial	3017	119	+ 0	+0	+ 0	+ 0	+ 0	+ 0
26.5R25 VSDL BS L5, Radial	2956	116	+20	+1	+1248	+2752	+937	+2066
750/65R25 MX L3, Radial Low Profile	3076	121	+ 0	+0	- 228	- 503	- 21	- 47
26.5-25 20 PR SRG FS L3, Bias	2992	118	-24	-1	- 324	- 714	-461	-1017
26.5-25 20 PR SHRL GY L3, Bias	2974	117	+ 0	+0	+ 41	+ 90	-127	- 280
26.5-25 SRG DT FS LDL4, Bias	3002	118	+20	+1	+ 34	+ 75	+ 31	+ 68

Bucket Type	General Purpose — Pin On										High Lift Delta
	Edge Type	Bolt-on Edges	Teeth & Segments	Teeth	Bolt-on Edges	Teeth & Segments	Teeth	Bolt-on Edges	Teeth & Segments	Teeth	
Capacity — rated	m <sup>3</sup> yd <sup>3</sup>	4.0 5.2	4.0 5.2	3.8 5.0	4.3 5.6	4.3 5.6	4.0 5.2	4.5 5.9	4.5 5.9	4.3 5.6	— —
Capacity — struck	m <sup>3</sup> yd <sup>3</sup>	3.4 4.5	3.4 4.5	3.3 4.3	3.6 4.7	3.6 4.7	3.4 4.5	3.8 5.0	3.8 5.0	3.7 4.8	— —
Width	mm ft/in	3059 10'0"	3145 10'3"	3145 10'3"	3220 10'6"	3306 10'10"	3306 10'10"	3220 10'6"	3306 10'10"	3306 10'10"	— —
Dump clearance at maximum lift and 45° discharge	mm ft/in	3288 10'9"	3136 10'3"	3136 10'3"	3288 10'9"	3136 10'3"	3136 10'3"	3248 10'7"	3095 10'1"	3095 10'1"	+336 +1'1"
Reach at maximum lift and 45° discharge	mm ft/in	1281 4'2"	1421 4'7"	1421 4'7"	1281 4'2"	1421 4'7"	1421 4'7"	1309 4'3"	1448 4'8"	1448 4'8"	+23 +0.9"
Reach at level lift arm and bucket level	mm ft/in	2867 9'4"	3072 10'0"	3072 10'0"	2867 9'4"	3072 10'0"	3072 10'0"	2917 9'6"	3122 10'2"	3122 10'2"	+274 +10.8"
Digging depth	mm in	108 4.2	108 4.2	78 3	108 4.2	108 4.2	78 3	108 4.2	108 4.2	78 3	-5 -0.2
Overall length	mm ft/in	9060 29'8"	9284 30'5"	9284 30'5"	9060 29'8"	9284 30'5"	9284 30'5"	9110 29'10"	9334 30'7"	9334 30'7"	+335 +1'1"
Overall height with bucket at maximum lift	mm ft/in	6055 19'10"	6055 19'10"	6055 19'10"	6055 19'10"	6055 19'10"	6055 19'10"	6101 20'0"	6101 20'0"	6101 20'0"	+336 +1'1"
Loader clearance circle with bucket at carry position	mm ft/in	14 731 48'3"	14 942 49'0"	14 942 49'0"	14 878 48'9"	15 087 49'5"	15 087 49'5"	14 905 48'10"	15 114 49'7"	15 114 49'7"	+327 +1'1"
Static tipping load — straight*	kg lb	17 870 39,386	17 688 38,984	18 038 39,755	17 886 39,421	17 675 38,957	18 063 39,811	17 661 38,926	17 451 38,462	17 841 39,321	-1522 -3354
Static tipping load — articulated* maximum 37° turn	kg lb	15 562 34,300	15 380 33,898	15 711 34,626	15 567 34,309	15 356 33,844	15 725 34,658	15 361 33,857	15 151 33,392	15 522 34,210	-1370 -3020
Breakout force**	kN lb	242 54,367	241 54,050	258 57,957	242 54,279	240 53,933	258 57,891	232 52,186	231 51,840	247 55,528	-7 -1557
Operating weight*	kg lb	25 329 55,824	25 469 56,133	25 317 55,798	25 405 55,992	25 572 56,360	25 381 55,939	25 459 56,111	25 626 56,479	25 435 56,058	+84 +186

\*Static tipping loads and operating weight are based on the following loader configuration: L3 Michelin XHA tires, air conditioning, ride control, power train guard, full fluids, fuel tank, coolant, lubricants and operator.

Static tipping loads conform to the international standard as defined in ISO 14397-1 (SEPT2007).

\*\*Measured 100 mm (4") behind tip of cutting edge with bucket hinge pin as pivot point in accordance with SAE J732 (APR2007).

**NOTE:** Specifications and ratings conform to all applicable standards recommended by the Society of Automotive Engineers, including SAE Standard J732 (APR2007) which governs loader ratings.

	Width over tires		Change in vertical dimensions		Change in operating weight		Change in static tipping load	
	mm	in	mm	in	kg	lb	kg	lb
	26.5R25 GP2B GY L2, Radial	3012	119	+ 0	+0	- 48	- 106	- 36
26.5R25 VMT BS L3, Radial	3015	119	+ 0	+0	+ 82	+ 181	- 14	- 31
26.5R25 RT3B GY L3, Radial	3017	119	+ 0	+0	+ 10	+ 22	+ 7	+ 15
26.5R25 XHA MX L3, Radial	3017	119	+ 0	+0	+ 0	+ 0	+ 0	+ 0
26.5R25 VSDL BS L5, Radial	2956	116	+20	+1	+1248	+2752	+937	+2066
750/65R25 MX L3, Radial Low Profile	3076	121	+ 0	+0	- 228	- 503	- 21	- 47
26.5-25 20 PR SRG FS L3, Bias	2992	118	-24	-1	- 324	- 714	-461	-1017
26.5-25 20 PR SHRL GY L3, Bias	2974	117	+ 0	+0	+ 41	+ 90	-127	- 280
26.5-25 SRG DT FS LDL4, Bias	3002	118	+20	+1	+ 34	+ 75	+ 31	+ 68

Bucket Type	General Purpose — Pin On						Material Handling — Pin On			High Lift Delta	
	Bolt-on Edges	Teeth & Seg-ments	Teeth	Bolt-on Edges	Teeth & Seg-ments	Teeth	Bolt-on Edges	Teeth & Seg-ments	Teeth		
Edge Type											
Capacity — rated	m <sup>3</sup> yd <sup>3</sup>	4.6 6.0	4.6 6.0	4.4 5.8	5.1 6.7	5.1 6.7	4.9 6.4	4.3 5.6	4.3 5.6	4.0 5.2	— —
Capacity — struck	m <sup>3</sup> yd <sup>3</sup>	4.0 5.2	4.0 5.2	3.9 5.0	4.5 5.9	4.5 5.9	4.3 5.6	3.7 4.8	3.7 4.8	3.5 4.6	— —
Width	mm ft/in	3220 10'6"	3306 10'10"	3306 10'10"	3220 10'6"	3306 10'10"	3306 10'10"	3220 10'6"	3306 10'10"	3306 10'10"	— —
Dump clearance at maximum lift and 45° discharge	mm ft/in	3232 10'7"	3080 10'1"	3080 10'1"	3154 10'4"	3000 9'10"	3000 9'10"	3207 10'6"	3044 9'11"	3044 9'11"	+336 +1'1"
Reach at maximum lift and 45° discharge	mm ft/in	1326 4'4"	1466 4'9"	1466 4'9"	1389 4'6"	1526 5'0"	1526 5'0"	1192 3'10"	1319 4'3"	1319 4'3"	+23 +0.9"
Reach at level lift arm and bucket level	mm ft/in	2939 9'7"	3144 10'3"	3144 10'3"	3041 9'11"	3246 10'7"	3246 10'7"	2882 9'5"	3087 10'1"	3087 10'1"	+274 +10.8"
Digging depth	mm in	118 4.6	118 4.6	88 3.4	118 4.6	118 4.6	88 3.4	108 4.2	108 4.2	78 3	-5 -0.2
Overall length	mm ft/in	9139 29'11"	9362 30'8"	9362 30'8"	9241 30'3"	9464 31'0"	9464 31'0"	9075 29'9"	9299 30'6"	9299 30'6"	+335 +1'1"
Overall height with bucket at maximum lift	mm ft/in	5995 19'8"	5995 19'8"	5995 19'8"	6119 20'0"	6119 20'0"	6119 20'0"	6051 19'10"	6051 19'10"	6051 19'10"	+336 +1'1"
Loader clearance circle with bucket at carry position	mm ft/in	14 924 48'11"	15 134 49'7"	15 134 49'7"	14 980 49'1"	15 191 49'10"	15 191 49'10"	14 886 48'10"	15 095 49'6"	15 095 49'6"	+327 +1'1"
Static tipping load — straight*	kg lb	17 949 39,559	17 739 39,096	18 128 39,954	17 875 39,397	17 675 38,955	18 043 39,766	17 581 38,748	17 373 38,289	17 755 39,132	-1522 -3354
Static tipping load — articulated* maximum 37° turn	kg lb	15 659 34,513	15 449 34,050	15 820 34,866	15 589 34,359	15 388 33,916	15 739 34,689	15 294 33,708	15 085 33,248	15 449 34,050	-1370 -3020
Breakout force**	kN lb	230 51,640	229 51,339	244 54,907	216 48,526	215 48,254	229 51,357	239 53,601	237 53,255	254 57,126	-7 -1557
Operating weight*	kg lb	25 041 55,189	25 208 55,557	25 017 55,136	25 182 55,500	25 349 55,868	25 158 55,447	25 452 56,095	25 619 56,463	25 428 56,042	+84 +186

\*Static tipping loads and operating weight are based on the following loader configuration: L3 Michelin XHA tires, air conditioning, ride control, power train guard, full fluids, fuel tank, coolant, lubricants and operator.

Static tipping loads conform to the international standard as defined in ISO 14397-1 (SEPT2007).

\*\*Measured 100 mm (4") behind tip of cutting edge with bucket hinge pin as pivot point in accordance with SAE J732 (APR2007).

**NOTE:** Specifications and ratings conform to all applicable standards recommended by the Society of Automotive Engineers, including SAE Standard J732 (APR2007) which governs loader ratings.

	Width over tires		Change in vertical dimensions		Change in operating weight		Change in static tipping load	
	mm	in	mm	in	kg	lb	kg	lb
	26.5R25 GP2B GY L2, Radial	3012	119	+ 0	+0	- 48	- 106	- 36
26.5R25 VMT BS L3, Radial	3015	119	+ 0	+0	+ 82	+ 181	- 14	- 31
26.5R25 RT3B GY L3, Radial	3017	119	+ 0	+0	+ 10	+ 22	+ 7	+ 15
26.5R25 XHA MX L3, Radial	3017	119	+ 0	+0	+ 0	+ 0	+ 0	+ 0
26.5R25 VSDL BS L5, Radial	2956	116	+20	+1	+1248	+2752	+937	+2066
750/65R25 MX L3, Radial Low Profile	3076	121	+ 0	+0	- 228	- 503	- 21	- 47
26.5-25 20 PR SRG FS L3, Bias	2992	118	-24	-1	- 324	- 714	-461	-1017
26.5-25 20 PR SHRL GY L3, Bias	2974	117	+ 0	+0	+ 41	+ 90	-127	- 280
26.5-25 SRG DT FS LDL4, Bias	3002	118	+20	+1	+ 34	+ 75	+ 31	+ 68

Bucket Type		Material Handling — Pin On			General Purpose — Fusion QC						High Lift Delta
		Bolt-on Edges	Teeth & Seg-ments	Teeth	Bolt-on Edges	Teeth & Seg-ments	Teeth	Bolt-on Edges	Teeth & Seg-ments	Teeth	
Edge Type											
Capacity — rated	m <sup>3</sup> yd <sup>3</sup>	4.7 6.2	4.7 6.2	4.5 5.9	4.2 5.5	4.2 5.5	4.0 5.2	4.8 6.3	4.8 6.3	4.6 6.0	— —
Capacity — struck	m <sup>3</sup> yd <sup>3</sup>	4.4 5.8	4.4 5.8	4.2 5.6	3.9 5.1	3.9 5.1	3.7 4.8	3.4 4.5	3.4 4.5	3.3 4.3	— —
Width	mm ft/in	3220 10'6"	3307 10'10"	3307 10'10"	3220 10'6"	3307 10'10"	3307 10'10"	3224 10'6"	3311 10'10"	3311 10'10"	— —
Dump clearance at maximum lift and 45° discharge	mm ft/in	3144 10'3"	2981 9'9"	2981 9'9"	3284 10'9"	3132 10'3"	3132 10'3"	3136 10'3"	2973 9'9"	2973 9'9"	+336 +1'1"
Reach at maximum lift and 45° discharge	mm ft/in	1256 4'1"	1383 4'6"	1383 4'6"	1286 4'2"	1425 4'8"	1425 4'8"	1275 4'2"	1402 4'7"	1402 4'7"	+23 +0.9"
Reach at level lift arm and bucket level	mm ft/in	2972 9'9"	3177 10'5"	3177 10'5"	2875 9'5"	3080 10'1"	3080 10'1"	2991 9'9"	3196 10'5"	3196 10'5"	+274 +10.8"
Digging depth	mm in	108 4.2	108 4.2	78 3	100 3.9	100 3.9	70 2.7	100 3.9	100 3.9	70 2.7	-5 -0.2
Overall length	mm ft/in	9165 30'0"	9389 30'9"	9389 30'9"	9062 29'8"	9286 30'5"	9286 30'5"	9178 30'1"	9402 30'10"	9402 30'10"	+335 +1'1"
Overall height with bucket at maximum lift	mm ft/in	6131 20'1"	6131 20'1"	6131 20'1"	6082 19'11"	6082 19'11"	6082 19'11"	6203 20'4"	6203 20'4"	6203 20'4"	+336 +1'1"
Loader clearance circle with bucket at carry position	mm ft/in	14 935 48'11"	15 146 49'8"	15 146 49'8"	14 869 48'9"	15 081 49'5"	15 081 49'5"	14 936 49'0"	15 150 49'8"	15 150 49'8"	+327 +1'1"
Static tipping load — straight*	kg lb	17 527 38,630	17 347 38,232	17 571 38,725	17 696 39,002	17 515 38,604	17 870 39,385	17 427 38,409	17 244 38,005	17 592 38,772	-1522 -3354
Static tipping load — articulated* maximum 37° turn	kg lb	15 237 33,582	15 056 33,183	15 264 33,641	15 365 33,864	15 184 33,466	15 520 34,206	15 108 33,298	14 925 32,894	15 255 33,622	-1370 -3020
Breakout force**	kN lb	222 49,987	221 49,676	236 53,064	240 53,979	239 53,671	256 57,554	220 49,371	218 49,064	233 52,373	-7 -1557
Operating weight*	kg lb	25 574 56,366	25 712 56,670	25 549 56,310	25 716 56,679	25 854 56,983	25 691 56,623	25 852 56,979	25 990 57,282	25 827 56,923	+84 +186

\*Static tipping loads and operating weight are based on the following loader configuration: L3 Michelin XHA tires, air conditioning, ride control, power train guard, full fluids, fuel tank, coolant, lubricants and operator.

Static tipping loads conform to the international standard as defined in ISO 14397-1 (SEPT2007).

\*\*Measured 100 mm (4") behind tip of cutting edge with bucket hinge pin as pivot point in accordance with SAE J732 (APR2007).

**NOTE:** Specifications and ratings conform to all applicable standards recommended by the Society of Automotive Engineers, including SAE Standard J732 (APR2007) which governs loader ratings.

	Width over tires		Change in vertical dimensions		Change in operating weight		Change in static tipping load	
	mm	in	mm	in	kg	lb	kg	lb
	26.5R25 GP2B GY L2, Radial	3012	119	+ 0	+0	- 48	- 106	- 36
26.5R25 VMT BS L3, Radial	3015	119	+ 0	+0	+ 82	+ 181	- 14	- 31
26.5R25 RT3B GY L3, Radial	3017	119	+ 0	+0	+ 10	+ 22	+ 7	+ 15
26.5R25 XHA MX L3, Radial	3017	119	+ 0	+0	+ 0	+ 0	+ 0	+ 0
26.5R25 VSDL BS L5, Radial	2956	116	+20	+1	+1248	+2752	+937	+2066
750/65R25 MX L3, Radial Low Profile	3076	121	+ 0	+0	- 228	- 503	- 21	- 47
26.5-25 20 PR SRG FS L3, Bias	2992	118	-24	-1	- 324	- 714	-461	-1017
26.5-25 20 PR SHRL GY L3, Bias	2974	117	+ 0	+0	+ 41	+ 90	-127	- 280
26.5-25 SRG DT FS LDL4, Bias	3002	118	+20	+1	+ 34	+ 75	+ 31	+ 68

Bucket Type		Material Handling — Fusion QC			Rock — Pin On	Heavy Duty Rock — Pin On	Waste — Pin On	High Lift Delta
		Bolt-on Edges	Teeth & Segments	Teeth	Teeth & Segments	Teeth & Segments	Bolt-on Edges	
Capacity — rated	m <sup>3</sup> yd <sup>3</sup>	4.6 6.0	4.6 6.0	4.4 5.8	4.0 5.2	4.0 5.2	6.4 8.3	— —
Capacity — struck	m <sup>3</sup> yd <sup>3</sup>	3.3 4.3	3.3 4.3	3.1 4.1	3.5 4.5	3.5 4.5	5.4 7.1	— —
Width	mm ft/in	3224 10'6"	3311 10'10"	3311 10'10"	3270 10'8"	3270 10'8"	3355 11'0"	— —
Dump clearance at maximum lift and 45° discharge	mm ft/in	3158 10'4"	2995 9'9"	2995 9'9"	3055 10'0"	3055 10'0"	3191 10'5"	+336 +1'1"
Reach at maximum lift and 45° discharge	mm ft/in	1253 4'1"	1380 4'6"	1380 4'6"	1640 5'4"	1640 5'4"	1173 3'10"	+23 +0.9"
Reach at level lift arm and bucket level	mm ft/in	2960 9'8"	3165 10'4"	3165 10'4"	3281 10'9"	3281 10'9"	2880 9'5"	+274 +10.8"
Digging depth	mm in	100 3.9	100 3.9	70 2.7	118 4.6	118 4.6	133 5.2	-5 -0.2
Overall length	mm ft/in	9147 30'0"	9371 30'8"	9371 30'8"	9483 31'1"	9483 31'1"	9091 29'9"	+335 +1'1"
Overall height with bucket at maximum lift	mm ft/in	6159 20'2"	6159 20'2"	6159 20'2"	6047 19'10"	6374 20'10"	6702 21'11"	+336 +1'1"
Loader clearance circle with bucket at carry position	mm ft/in	14 919 48'11"	15 133 49'7"	15 133 49'7"	15 312 50'2"	15 312 50'2"	15 027 49'3"	+327 +1'1"
Static tipping load — straight*	kg lb	17 426 38,408	17 245 38,008	17 588 38,763	17 473 38,510	17 333 38,203	18 168 40,043	-1522 -3354
Static tipping load — articulated* maximum 37° turn	kg lb	15 118 33,320	14 936 32,919	15 262 33,638	15 143 33,375	15 003 33,066	15 732 34,674	-1370 -3020
Breakout force**	kN lb	225 50,547	224 50,240	239 53,689	214 48,038	213 47,781	236 53,045	-7 -1557
Operating weight*	kg lb	25 790 56,841	25 928 57,145	25 765 56,785	25 794 56,849	25 968 57,232	25 944 57,180	+84 +186

\*Static tipping loads and operating weight are based on the following loader configuration: L3 Michelin XHA tires, air conditioning, ride control, power train guard, full fluids, fuel tank, coolant, lubricants and operator.

Static tipping loads conform to the international standard as defined in ISO 14397-1 (SEPT2007).

\*\*Measured 100 mm (4") behind tip of cutting edge with bucket hinge pin as pivot point in accordance with SAE J732 (APR2007).

**NOTE:** Specifications and ratings conform to all applicable standards recommended by the Society of Automotive Engineers, including SAE Standard J732 (APR2007) which governs loader ratings.

	Width over tires		Change in vertical dimensions		Change in operating weight		Change in static tipping load	
	mm	in	mm	in	kg	lb	kg	lb
	26.5R25 GP2B GY L2, Radial	3012	119	+ 0	+0	- 48	- 106	- 36
26.5R25 VMT BS L3, Radial	3015	119	+ 0	+0	+ 82	+ 181	- 14	- 31
26.5R25 RT3B GY L3, Radial	3017	119	+ 0	+0	+ 10	+ 22	+ 7	+ 15
26.5R25 XHA MX L3, Radial	3017	119	+ 0	+0	+ 0	+ 0	+ 0	+ 0
26.5R25 VSDL BS L5, Radial	2956	116	+20	+1	+1248	+2752	+937	+2066
750/65R25 MX L3, Radial Low Profile	3076	121	+ 0	+0	- 228	- 503	- 21	- 47
26.5-25 20 PR SRG FS L3, Bias	2992	118	-24	-1	- 324	- 714	-461	-1017
26.5-25 20 PR SHRL GY L3, Bias	2974	117	+ 0	+0	+ 41	+ 90	-127	- 280
26.5-25 SRG DT FS LDL4, Bias	3002	118	+20	+1	+ 34	+ 75	+ 31	+ 68

Bucket Type	Performance Series General Purpose — Pin On									High Lift Delta	
		Bolt-on Edges	Teeth & Seg-ments	Teeth	Bolt-on Edges	Teeth & Seg-ments	Teeth	Bolt-on Edges	Teeth & Seg-ments		Teeth
Edge Type											
Capacity — rated	m <sup>3</sup> yd <sup>3</sup>	5.3 7.0	5.3 7.0	4.6 6.0	5.7 7.5	5.7 7.5	5.4 7.0	6.0 7.8	6.0 7.8	5.7 7.5	— —
Capacity — struck	m <sup>3</sup> yd <sup>3</sup>	4.7 6.1	4.7 6.1	4.7 6.1	5.1 6.7	5.1 6.7	5.1 6.7	5.3 6.9	5.3 6.9	5.3 6.9	— —
Width	mm ft/in	3447 11'3"	3447 11'3"	3447 11'3"	3447 11'3"	3447 11'3"	3447 11'3"	3447 11'3"	3447 11'3"	3447 11'3"	— —
Dump clearance at maximum lift and 45° discharge	mm ft/in	3234 10'7"	3234 10'7"	3234 10'7"	3170 10'4"	3170 10'4"	3170 10'4"	3151 10'4"	3151 10'4"	3151 10'4"	+221 +8.7"
Reach at maximum lift and 45° discharge	mm ft/in	1573 5'1"	1573 5'1"	1573 5'1"	1626 5'4"	1626 5'4"	1626 5'4"	1649 5'4"	1649 5'4"	1649 5'4"	+3 +0.1"
Reach at level lift arm and bucket level	mm ft/in	3063 10'0"	3063 10'0"	3063 10'0"	3147 10'3"	3147 10'3"	3147 10'3"	3176 10'5"	3176 10'5"	3176 10'5"	+160 +6.3"
Digging depth	mm in	138 5.4	138 5.4	138 5.4	138 5.4	138 5.4	138 5.4	138 5.4	138 5.4	138 5.4	-2 -0.1
Overall length	mm ft/in	9520 31'2"	9520 31'2"	9520 31'2"	9604 31'6"	9604 31'6"	9604 31'6"	9633 31'7"	9633 31'7"	9633 31'7"	+199 +7.8"
Overall height with bucket at maximum lift	mm ft/in	6135 20'1"	6135 20'1"	6135 20'1"	6208 20'4"	6208 20'4"	6208 20'4"	6233 20'5"	6233 20'5"	6233 20'5"	+221 +8.7"
Loader clearance circle with bucket at carry position	mm ft/in	15 856 52'0"	15 856 52'0"	15 856 52'0"	15 900 52'1"	15 900 52'1"	15 900 52'1"	15 916 52'2"	15 916 52'2"	15 916 52'2"	+167 +6.6"
Static tipping load — straight*	kg lb	21 079 46,459	21 079 46,459	21 079 46,459	22 272 49,088	22 272 49,088	22 272 49,088	22 312 49,176	22 312 49,176	22 312 49,176	-1794 -3955
Static tipping load — articulated* maximum 37° turn	kg lb	18 447 40,657	18 447 40,657	18 447 40,657	19 447 42,860	19 447 42,860	19 447 42,860	19 487 42,950	19 487 42,950	19 487 42,950	-1616 -3561
Breakout force**	kN lb	202 45,452	202 45,452	202 45,452	191 42,856	191 42,856	191 42,856	187 42,092	187 42,092	187 42,092	+3 +749
Operating weight*	kg lb	30 188 66,535	30 188 66,535	30 188 66,535	30 990 68,302	30 990 68,302	30 990 68,302	30 925 68,158	30 925 68,158	30 925 68,158	+114 +252

\*Static tipping loads and operating weight are based on the following loader configuration: L3 Michelin XHA tires, air conditioning, ride control, power train guard, full fluids, fuel tank, coolant, lubricants and operator.

\*\*Static tipping loads conform to the international standard as defined in ISO 14397-1 (SEPT2007).

\*\*Measured 100 mm (4") behind tip of cutting edge with bucket hinge pin as pivot point in accordance with SAE J732 (APR2007).

**NOTE:** Specifications and ratings conform to all applicable standards recommended by the Society of Automotive Engineers, including SAE Standard J732 (APR2007) which governs loader ratings.

	Width over tires		Change in vertical dimensions		Change in operating weight		Change in static tipping load	
	mm	in	mm	in	kg	lb	kg	lb
	29.5R25, (L-2/L-3), Goodyear . . . . .	3269	129	+21	+1	- 91	- 201	+ 129
29.5R25, (L-3), Michelin . . . . .	3227	127	+ 0	+0	+ 0	+ 0	+ 0	+ 0
29.5R25, (L-3 STL2+), Continental . . . . .	3264	129	+10	+0	+ 71	+ 157	+ 509	+1122
29.5R25, (L-3 STL3), Continental . . . . .	3264	129	+ 8	+0	- 16	- 35	+ 441	+ 972
29.5R25, (L-3 VMT), Bridgestone . . . . .	3211	126	+27	+1	+ 93	+ 205	+ 43	+ 95
29.5R25, (L-3 VSDL), Bridgestone . . . . .	3202	126	+37	+2	+1311	+2891	+1245	+2745
29.5R25, (L-5), Michelin . . . . .	3212	127	+16	+0	+ 836	+1843	+ 587	+1294
29.5R25, (L-5), Michelin . . . . .	3231	127	+25	+1	+1318	+2906	+1058	+2333
29.5-25, (L-3), Goodyear . . . . .	3253	128	+ 2	+0	- 297	- 655	- 206	- 454
29.5-25, (L-4), Firestone . . . . .	3194	126	+39	+2	+ 75	+ 165	- 460	-1014
29.5-25, (L-4), Goodyear . . . . .	3284	129	+41	+2	+ 330	+ 728	+ 411	+ 906
29.5-25, (L-5), Firestone . . . . .	3197	126	+46	+2	+ 613	+1352	+ 859	+1894
29.5-25, (L-5), Goodyear . . . . .	3266	129	+46	+2	+ 942	+2077	+ 943	+2079

Bucket Type	General Purpose — Pin On									High Lift Delta	
	Bolt-on Edges	Teeth & Seg-ments	Teeth	Bolt-on Edges	Teeth & Seg-ments	Teeth	Bolt-on Edges	Teeth & Seg-ments	Teeth		
Edge Type											
Capacity — rated	m <sup>3</sup> yd <sup>3</sup>	4.6 6.0	4.5 5.9	4.2 5.5	5.0 6.5	4.9 6.4	4.7 6.2	5.4 7.1	5.4 7.1	5.0 6.5	— —
Capacity — struck	m <sup>3</sup> yd <sup>3</sup>	3.9 5.1	3.8 5.0	3.7 4.8	4.2 5.6	4.2 5.5	4.0 5.3	4.6 6.0	4.5 6.0	4.4 5.7	— —
Width	mm ft/in	3447 11'3"	3533 11'7"	3533 11'7"	3447 11'3"	3533 11'7"	3533 11'7"	3447 11'3"	3533 11'7"	3533 11'7"	— —
Dump clearance at maximum lift and 45° discharge	mm ft/in	3445 11'3"	3292 10'9"	3292 10'9"	3372 11'0"	3216 10'6"	3216 10'6"	3309 10'10"	3152 10'4"	3152 10'4"	+221 +8.7"
Reach at maximum lift and 45° discharge	mm ft/in	1407 4'7"	1554 5'1"	1554 5'1"	1457 4'9"	1601 5'3"	1601 5'3"	1505 4'11"	1647 5'4"	1647 5'4"	+3 +0.1"
Reach at level lift arm and bucket level	mm ft/in	2790 9'1"	3000 9'10"	3000 9'10"	2880 9'5"	3090 10'1"	3090 10'1"	2960 9'8"	3170 10'4"	3170 10'4"	+160 +6.3"
Digging depth	mm in	138 5.4	138 5.4	103 4	138 5.4	138 5.4	103 4	138 5.4	138 5.4	103 4	-2 -0.1
Overall length	mm ft/in	9248 30'4"	9480 31'1"	9480 31'1"	9338 30'7"	9570 31'4"	9570 31'4"	9418 30'10"	9650 31'7"	9650 31'7"	+199 +7.8"
Overall height with bucket at maximum lift	mm ft/in	6128 20'1"	6128 20'1"	6128 20'1"	6204 20'4"	6204 20'4"	6204 20'4"	6274 20'7"	6274 20'7"	6274 20'7"	+221 +8.7"
Loader clearance circle with bucket at carry position	mm ft/in	15 716 51'6"	15 925 52'2"	15 925 52'2"	15 762 51'8"	15 972 52'4"	15 972 52'4"	15 803 51'10"	16 015 52'6"	16 015 52'6"	+167 +6.6"
Static tipping load — straight*	kg lb	22 109 48,728	22 077 48,658	22 435 49,446	21 870 48,201	21 836 48,127	22 187 48,900	21 664 47,747	21 629 47,671	21 976 48,435	-1794 -3955
Static tipping load — articulated* maximum 37° turn	kg lb	19 428 42,819	19 391 42,738	19 727 43,479	19 202 42,322	19 165 42,239	19 494 42,966	19 008 41,894	18 969 41,807	19 295 42,526	-1616 -3561
Breakout force**	kN lb	252 56,546	251 56,287	273 61,279	234 52,587	233 52,341	252 56,677	220 49,468	219 49,231	236 53,088	+3 +749
Operating weight*	kg lb	29 792 65,661	29 865 65,822	29 686 65,429	29 889 65,876	29 963 66,037	29 784 65,644	29 979 66,074	30 052 66,235	29 874 65,841	+114 +252

\*Static tipping loads and operating weight are based on the following loader configuration: L3 Michelin XHA tires, air conditioning, ride control, power train guard, full fluids, fuel tank, coolant, lubricants and operator.

Static tipping loads conform to the international standard as defined in ISO 14397-1 (SEPT2007).

\*\*Measured 100 mm (4") behind tip of cutting edge with bucket hinge pin as pivot point in accordance with SAE J732 (APR2007).

**NOTE:** Specifications and ratings conform to all applicable standards recommended by the Society of Automotive Engineers, including SAE Standard J732 (APR2007) which governs loader ratings.

	Width over tires		Change in vertical dimensions		Change in operating weight		Change in static tipping load	
	mm	in	mm	in	kg	lb	kg	lb
	29.5R25, (L-2/L-3), Goodyear	3269	129	+21	+1	- 91	- 201	+ 129
29.5R25, (L-3), Michelin	3227	127	+ 0	+0	+ 0	+ 0	+ 0	+ 0
29.5R25, (L-3 STL2+), Continental	3264	129	+10	+0	+ 71	+ 157	+ 509	+1122
29.5R25, (L-3 STL3), Continental	3264	129	+ 8	+0	- 16	- 35	+ 441	+ 972
29.5R25, (L-3 VMT), Bridgestone	3211	126	+27	+1	+ 93	+ 205	+ 43	+ 95
29.5R25, (L-3 VSDL), Bridgestone	3202	126	+37	+2	+1311	+2891	+1245	+2745
29.5R25, (L-5), Michelin	3212	127	+16	+0	+ 836	+1843	+ 587	+1294
29.5R25, (L-5), Michelin	3231	127	+25	+1	+1318	+2906	+1058	+2333
29.5-25, (L-3), Goodyear	3253	128	+ 2	+0	- 297	- 655	- 206	- 454
29.5-25, (L-4), Firestone	3194	126	+39	+2	+ 75	+ 165	- 460	-1014
29.5-25, (L-4), Goodyear	3284	129	+41	+2	+ 330	+ 728	+ 411	+ 906
29.5-25, (L-5), Firestone	3197	126	+46	+2	+ 613	+1352	+ 859	+1894
29.5-25, (L-5), Goodyear	3266	129	+46	+2	+ 942	+2077	+ 943	+2079



Bucket Type	General Purpose — Pin On								High Lift Delta
	Flushmounted Adapter with Teeth	Bolt-on Edges	Teeth & Seg-ments	Teeth	Bolt-on Edges	Teeth & Seg-ments	Teeth		
Edge Type									
Capacity — rated	m <sup>3</sup> yd <sup>3</sup>	5.4 7.1	5.7 7.5	5.6 7.3	5.4 7.1	6.1 8.0	6.0 7.9	5.7 7.5	— —
Capacity — struck	m <sup>3</sup> yd <sup>3</sup>	4.7 6.1	4.9 6.4	4.9 6.3	4.7 6.1	5.2 6.8	5.1 6.7	4.8 6.3	— —
Width	mm ft/in	3513 11'6"	3447 11'3"	3533 11'7"	3533 11'7"	3447 11'3"	3533 11'7"	3533 11'7"	— —
Dump clearance at maximum lift and 45° discharge	mm ft/in	3125 10'3"	3269 10'8"	3111 10'2"	3111 10'2"	3225 10'6"	3062 10'0"	3062 10'0"	+221 +8.7"
Reach at maximum lift and 45° discharge	mm ft/in	1739 5'8"	1534 5'0"	1675 5'5"	1675 5'5"	1594 5'2"	1729 5'8"	1729 5'8"	+3 +0.1"
Reach at level lift arm and bucket level	mm ft/in	3260 10'8"	3010 9'10"	3220 10'6"	3220 10'6"	3083 10'1"	3292 10'9"	3292 10'9"	+160 +6.3"
Digging depth	mm in	104 4	138 5.4	138 5.4	103 4	138 5.4	138 5.4	112 4.3	-2 -0.1
Overall length	mm ft/in	9700 31'9"	9468 31'0"	9700 31'9"	9700 31'9"	9540 31'3"	9778 32'0"	9778 32'0"	+199 +7.8"
Overall height with bucket at maximum lift	mm ft/in	6203 20'4"	6347 20'9"	6347 20'9"	6347 20'9"	6438 21'1"	6438 21'1"	6438 21'1"	+221 +8.7"
Loader clearance circle with bucket at carry position	mm ft/in	16 006 52'6"	15 829 51'11"	16 041 52'7"	16 041 52'7"	15 868 52'0"	16 087 52'9"	16 087 52'9"	+167 +6.6"
Static tipping load — straight*	kg lb	21 786 48,016	21 527 47,446	21 492 47,368	21 836 48,126	21 285 46,913	21 249 46,832	21 617 47,643	-1794 -3955
Static tipping load — articulated* maximum 37° turn	kg lb	19 112 42,122	18 878 41,607	18 838 41,519	19 161 42,232	18 627 41,054	18 583 40,957	18 929 41,718	-1616 -3561
Breakout force**	kN lb	227 51,112	212 47,653	211 47,421	227 51,017	199 44,786	198 44,485	213 47,761	+3 +749
Operating weight*	kg lb	29 882 65,860	30 050 66,231	30 124 66,393	29 945 65,999	30 203 66,567	30 294 66,769	30 119 66,382	+114 +252

\*Static tipping loads and operating weight are based on the following loader configuration: L3 Michelin XHA tires, air conditioning, ride control, power train guard, full fluids, fuel tank, coolant, lubricants and operator.

Static tipping loads conform to the international standard as defined in ISO 14397-1 (SEPT2007).

\*\*Measured 100 mm (4") behind tip of cutting edge with bucket hinge pin as pivot point in accordance with SAE J732 (APR2007).

**NOTE:** Specifications and ratings conform to all applicable standards recommended by the Society of Automotive Engineers, including SAE Standard J732 (APR2007) which governs loader ratings.

	Width over tires		Change in vertical dimensions		Change in operating weight		Change in static tipping load	
	mm	in	mm	in	kg	lb	kg	lb
29.5R25, (L-2/L-3), Goodyear	3269	129	+21	+1	- 91	- 201	+ 129	+ 284
29.5R25, (L-3), Michelin	3227	127	+ 0	+0	+ 0	+ 0	+ 0	+ 0
29.5R25, (L-3 STL2+), Continental	3264	129	+10	+0	+ 71	+ 157	+ 509	+1122
29.5R25, (L-3 STL3), Continental	3264	129	+ 8	+0	- 16	- 35	+ 441	+ 972
29.5R25, (L-3 VMT), Bridgestone	3211	126	+27	+1	+ 93	+ 205	+ 43	+ 95
29.5R25, (L-3 VSDL), Bridgestone	3202	126	+37	+2	+1311	+2891	+1245	+2745
29.5R25, (L-5), Michelin	3212	127	+16	+0	+ 836	+1843	+ 587	+1294
29.5R25, (L-5), Michelin	3231	127	+25	+1	+1318	+2906	+1058	+2333
29.5-25, (L-3), Goodyear	3253	128	+ 2	+0	- 297	- 655	- 206	- 454
29.5-25, (L-4), Firestone	3194	126	+39	+2	+ 75	+ 165	- 460	-1014
29.5-25, (L-4), Goodyear	3284	129	+41	+2	+ 330	+ 728	+ 411	+ 906
29.5-25, (L-5), Firestone	3197	126	+46	+2	+ 613	+1352	+ 859	+1894
29.5-25, (L-5), Goodyear	3266	129	+46	+2	+ 942	+2077	+ 943	+2079

Bucket Type	Heavy Duty General Purpose — Pin On			Material Handling — Pin On			Rock — Pin On			High Lift Delta	
	Edge Type	Bolt-on Edges	Teeth & Seg- ments	Teeth	Bolt-on Edges	Teeth & Seg- ments	Teeth	Teeth	Teeth & Seg- ments		Teeth & Seg- ments
Capacity — rated	m <sup>3</sup>	5.4	5.4	5.0	6.1	6.0	5.7	4.2	4.5	4.5	—
	yd <sup>3</sup>	7.1	7.1	6.5	8.0	7.9	7.5	5.5	5.9	5.9	—
Capacity — struck	m <sup>3</sup>	4.6	4.5	4.4	5.2	5.1	4.8	3.5	3.7	3.7	—
	yd <sup>3</sup>	6.0	6.0	5.7	6.8	6.7	6.3	4.6	4.9	4.9	—
Width	mm	3447	3533	3533	3447	3533	3533	3504	3504	3504	—
	ft/in	11'3"	11'7"	11'7"	11'3"	11'7"	11'7"	11'5"	11'5"	11'5"	—
Dump clearance at maximum lift and 45° discharge	mm	3283	3129	3129	3097	2930	2930	3170	3170	3171	+221
	ft/in	10'9"	10'3"	10'3"	10'1"	9'7"	9'7"	10'4"	10'4"	10'4"	+8.7"
Reach at maximum lift and 45° discharge	mm	1547	1693	1693	1478	1610	1610	1792	1792	1792	+3
	ft/in	5'0"	5'6"	5'6"	4'10"	5'3"	5'3"	5'10"	5'10"	5'10"	+0.1"
Reach at level lift arm and bucket level	mm	3009	3220	3220	3109	3320	3320	3258	3258	3258	+160
	ft/in	9'10"	10'6"	10'6"	10'2"	10'10"	10'10"	10'8"	10'8"	10'8"	+6.3"
Digging depth	mm	131	131	91	164	204	124	103	138	138	-2
	in	5.1	5.1	3.5	6.4	8	4.8	4	5.4	5.4	-0.1
Overall length	mm	9461	9691	9691	9586	9816	9816	9725	9725	9725	+199
	ft/in	31'0"	31'9"	31'9"	31'5"	32'2"	32'2"	31'10"	31'10"	31'10"	+7.8"
Overall height with bucket at maximum lift	mm	6274	6274	6274	6369	6369	6369	6370	6370	6369	+221
	ft/in	20'7"	20'7"	20'7"	20'10"	20'10"	20'10"	20'10"	20'10"	20'10"	+8.7"
Loader clearance circle with bucket at carry position	mm	15 823	16 033	16 033	15 901	16 111	16 111	16 023	16 023	16 023	+167
	ft/in	51'10"	52'7"	52'7"	52'2"	52'10"	52'10"	52'6"	52'6"	52'6"	+6.6"
Static tipping load — straight*	kg	20 789	20 732	21 074	20 457	20 418	20 788	21 713	21 173	21 377	-1794
	lb	45,819	45,694	46,448	45,087	45,002	45,816	47,855	46,666	47,115	-3955
Static tipping load — articulated* maximum 37° turn	kg	18 133	18 072	18 393	17 864	17 818	18 164	19 032	18 513	18 696	-1616
	lb	39,965	39,830	40,539	39,371	39,271	40,034	41,946	40,803	41,206	-3561
Breakout force**	kN	210	209	225	194	182	207	223	205	205	+3
	lb	47,193	46,980	50,500	43,585	40,802	46,438	50,134	46,041	46,053	+749
Operating weight*	kg	30 769	30 860	30 685	30 483	30 575	30 399	30 025	30 306	30 276	+114
	lb	67,815	68,016	67,629	67,185	67,386	66,999	66,175	66,795	66,728	+252

\*Static tipping loads and operating weight are based on the following loader configuration: L3 Michelin XHA tires, air conditioning, ride control, power train guard, full fluids, fuel tank, coolant, lubricants and operator.

Static tipping loads conform to the international standard as defined in ISO 14397-1 (SEPT2007).

\*\*Measured 100 mm (4") behind tip of cutting edge with bucket hinge pin as pivot point in accordance with SAE J732 (APR2007).

**NOTE:** Specifications and ratings conform to all applicable standards recommended by the Society of Automotive Engineers, including SAE Standard J732 (APR2007) which governs loader ratings.

	Width over tires		Change in vertical dimensions		Change in operating weight		Change in static tipping load	
	mm	in	mm	in	kg	lb	kg	lb
	29.5R25, (L-2/L-3), Goodyear	3269	129	+21	+1	- 91	- 201	+ 129
29.5R25, (L-3), Michelin	3227	127	+ 0	+0	+ 0	+ 0	+ 0	+ 0
29.5R25, (L-3 STL2+), Continental	3264	129	+10	+0	+ 71	+ 157	+ 509	+1122
29.5R25, (L-3 STL3), Continental	3264	129	+ 8	+0	- 16	- 35	+ 441	+ 972
29.5R25, (L-3 VMT), Bridgestone	3211	126	+27	+1	+ 93	+ 205	+ 43	+ 95
29.5R25, (L-3 VSDL), Bridgestone	3202	126	+37	+2	+1311	+2891	+1245	+2745
29.5R25, (L-5), Michelin	3212	127	+16	+0	+ 836	+1843	+ 587	+1294
29.5R25, (L-5), Michelin	3231	127	+25	+1	+1318	+2906	+1058	+2333
29.5-25, (L-3), Goodyear	3253	128	+ 2	+0	- 297	- 655	- 206	- 454
29.5-25, (L-4), Firestone	3194	126	+39	+2	+ 75	+ 165	- 460	-1014
29.5-25, (L-4), Goodyear	3284	129	+41	+2	+ 330	+ 728	+ 411	+ 906
29.5-25, (L-5), Firestone	3197	126	+46	+2	+ 613	+1352	+ 859	+1894
29.5-25, (L-5), Goodyear	3266	129	+46	+2	+ 942	+2077	+ 943	+2079

Bucket Type		Spade Rock — Pin On		Heavy Duty Quarry Spade Rock — Pin On	Waste — Pin On	Coal — Pin On	High Lift Delta
		Bolt-on Edges	Bolt-on Edges	Teeth & Segments	Bolt-on Edges	Bolt-on Edges	
Capacity — rated	m <sup>3</sup> yd <sup>3</sup>	4.3 5.6	4.7 6.2	4.5 5.9	10.5 13.7	8.2 10.7	— —
Capacity — struck	m <sup>3</sup> yd <sup>3</sup>	3.7 4.8	4.0 5.2	3.8 5.0	9.4 12.3	7.4 9.7	— —
Width	mm ft/in	3516 11'6"	3670 12'0"	3500 11'5"	3886 12'8"	3607 11'10"	— —
Dump clearance at maximum lift and 45° discharge	mm ft/in	3338 10'11"	3273 10'8"	3154 10'4"	2890 9'5"	2920 9'6"	+221 +8.7"
Reach at maximum lift and 45° discharge	mm ft/in	1591 5'2"	1668 5'5"	1821 5'11"	1686 5'6"	1662 5'5"	+3 +0.1"
Reach at level lift arm and bucket level	mm ft/in	2997 9'9"	3097 10'1"	3291 10'9"	3402 11'1"	3364 11'0"	+160 +6.3"
Digging depth	mm in	138 5.4	144 5.6	130 5.1	164 6.4	159 6.2	-2 -0.1
Overall length	mm ft/in	9455 31'0"	9559 31'4"	9755 32'0"	9879 32'4"	9837 32'3"	+199 +7.8"
Overall height with bucket at maximum lift	mm ft/in	6364 20'10"	6364 20'10"	6370 20'10"	6981 22'10"	6513 21'4"	+221 +8.7"
Loader clearance circle with bucket at carry position	mm ft/in	15 886 52'1"	16 083 52'9"	16 034 52'7"	16 458 53'11"	16 180 53'1"	+167 +6.6"
Static tipping load — straight*	kg lb	21 597 47,599	21 129 46,569	20 444 45,058	20 620 45,446	20 403 44,969	-1794 -3955
Static tipping load — articulated* maximum 37° turn	kg lb	18 918 41,694	18 466 40,698	17 790 39,209	17 895 39,440	17 819 39,272	-1616 -3561
Breakout force**	kN lb	213 47,788	197 44,299	203 45,594	160 35,896	163 36,693	+3 +749
Operating weight*	kg lb	30 096 66,331	30 361 66,916	30 920 68,148	31 130 68,611	30 506 67,235	+114 +252

\*Static tipping loads and operating weight are based on the following loader configuration: L3 Michelin XHA tires, air conditioning, ride control, power train guard, full fluids, fuel tank, coolant, lubricants and operator.

Static tipping loads conform to the international standard as defined in ISO 14397-1 (SEPT2007).

\*\*Measured 100 mm (4") behind tip of cutting edge with bucket hinge pin as pivot point in accordance with SAE J732 (APR2007).

**NOTE:** Specifications and ratings conform to all applicable standards recommended by the Society of Automotive Engineers, including SAE Standard J732 (APR2007) which governs loader ratings.

	Width over tires		Change in vertical dimensions		Change in operating weight		Change in static tipping load	
	mm	in	mm	in	kg	lb	kg	lb
29.5R25, (L-2/L-3), Goodyear	3269	129	+21	+1	- 91	- 201	+ 129	+ 284
29.5R25, (L-3), Michelin	3227	127	+ 0	+0	+ 0	+ 0	+ 0	+ 0
29.5R25, (L-3 STL2+), Continental	3264	129	+10	+0	+ 71	+ 157	+ 509	+1122
29.5R25, (L-3 STL3), Continental	3264	129	+ 8	+0	- 16	- 35	+ 441	+ 972
29.5R25, (L-3 VMT), Bridgestone	3211	126	+27	+1	+ 93	+ 205	+ 43	+ 95
29.5R25, (L-3 VSDL), Bridgestone	3202	126	+37	+2	+1311	+2891	+1245	+2745
29.5R25, (L-5), Michelin	3212	127	+16	+0	+ 836	+1843	+ 587	+1294
29.5R25, (L-5), Michelin	3231	127	+25	+1	+1318	+2906	+1058	+2333
29.5-25, (L-3), Goodyear	3253	128	+ 2	+0	- 297	- 655	- 206	- 454
29.5-25, (L-4), Firestone	3194	126	+39	+2	+ 75	+ 165	- 460	-1014
29.5-25, (L-4), Goodyear	3284	129	+41	+2	+ 330	+ 728	+ 411	+ 906
29.5-25, (L-5), Firestone	3197	126	+46	+2	+ 613	+1352	+ 859	+1894
29.5-25, (L-5), Goodyear	3266	129	+46	+2	+ 942	+2077	+ 943	+2079

Bucket Type			3.88 Meter Linkage — Tires: 35/65 R33 XLDD1 — SLR: 955 mm					
			General Purpose		Rock			
Ground Engaging Tools			Bolt-on Edges	Bolt-on Edges	Teeth & Segments	Teeth & Segments	Teeth & Segments	Teeth & Segments
Cutting Edge Type			Straight	Straight	Spade	Spade	Spade	Spade
Bucket Part No. (Group Level)			333-0931	333-0921	329-1611	333-0891	333-0911	333-0950
Struck capacity – ISO	m <sup>3</sup>		5.6	6.3	6.4	5.6	5.1	5.1
		yd <sup>3</sup>	7.3	8.2	8.4	7.3	6.7	6.7
Heaped capacity – ISO	m <sup>3</sup>		6.9	7.6	7.7	6.9	6.4	6.4
		yd <sup>3</sup>	9.0	10.0	10.0	9.0	8.3	8.3
Overall height	mm		7634	7738	7707	7605	7530	7530
		ft/in	25'1"	25'5"	25'3"	24'11"	24'8"	24'8"
Dump clearance at full lift and 45° discharge	With teeth	mm	—	—	3236	3314	3371	3345
		ft/in	—	—	10'7"	10'10"	11'1"	11'0"
	Bare	mm	3730	3646	3429	3507	3563	3513
		ft/in	12'3"	12'0"	11'3"	11'6"	11'8"	11'6"
Reach at full lift and 45° discharge	With teeth	mm	—	—	2231	2153	2097	2100
		ft/in	—	—	7'4"	7'1"	6'11"	6'11"
	Bare	mm	1754	1832	2047	1970	1913	1942
		ft/in	5'9"	6'0"	6'9"	6'6"	6'3"	6'4"
Reach level boom and level bucket	With teeth	mm	—	—	4492	4382	4302	4323
		ft/in	—	—	14'9"	14'5"	14'1"	14'2"
	Bare	mm	3806	3920	4226	4116	4036	4092
		ft/in	12'6"	12'10"	13'10"	13'6"	13'3"	13'5"
Digging depth	mm		227	232	232	232	232	247
		in	9	9	9	9	9	10
Overall length bucket level ground	mm		11 830	11 947	12 520	12 410	12 330	12 361
		ft/in	38'10"	39'2"	41'1"	40'9"	40'5"	40'7"
Turning radius — teeth corner SAE carry	mm		8680	8712	8791	8762	8740	8753
		ft/in	28'6"	28'7"	28'10"	28'9"	28'8"	28'9"
Reach at 45° dump and 2.13 m (7'0") height	With teeth	mm	—	—	3340	2984	2953	2945
		ft/in	—	—	10'11"	9'9"	9'8"	9'8"
	Bare	mm	2745	2794	3180	2800	2769	2787
		ft/in	9'0"	9'2"	10'5"	9'2"	9'1"	9'2"
Full dump at maximum lift	degrees		-51.4	-51.4	-51.4	-51.4	-51.4	-51.4
Static tipping load*, straight	kg		33 040	32 692	31 860	32 195	32 435	31 338
		lb	72,841	72,073	70,240	70,978	71,508	69,089
Static tipping load*, 35° turn	kg		28 362	28 015	27 206	27 539	27 779	26 683
		lb	62,528	61,762	59,978	60,713	61,242	58,826
Static tipping load*, full 43° turn	kg		26 279	25 931	25 132	25 465	25 705	24 609
		lb	57,935	57,168	55,406	56,140	56,669	54,254
Static tipping load**, straight	kg		34 724	34 390	33 539	33 861	34 088	32 984
		lb	76,553	75,817	73,941	74,651	75,151	72,717
Static tipping load**, 35° turn	kg		31 057	30 731	29 895	30 210	30 432	29 326
		lb	68,469	67,750	65,907	66,602	67,091	64,653
Static tipping load**, full 43° turn	kg		29 277	28 954	28 127	28 437	28 658	27 550
		lb	64,545	63,833	62,009	62,693	63,180	60,737
Breakout force — SAE rated	kg		49 062	45 977	39 289	41 531	43 299	41 607
		lb	108,164	101,361	86,617	91,560	95,549	91,728
Operating weight	kg		49 598	49 835	50 360	50 144	49 986	51 093
		lb	109,346	109,868	111,025	110,549	110,201	112,641
Weight distribution at SAE carry	Front	kg	25 326	25 746	26 752	26 362	26 076	28 005
		lb	55,834	56,761	58,979	58,117	57,489	61,741
	Rear	kg	24 272	24 089	23 608	23 783	23 910	23 088
		lb	53,511	53,107	52,047	52,432	52,712	50,901

Tire spec used for Tipping Load specifications includes 35-65R33 (L-4) Michelin XLDD1 tires.

\*Tipping Loads were calculated within guidelines of ISO 14397-1:2007 to include tire squash [Tire pressure at 634 kPa (92 psi)].

\*\*Tipping Load is calculated without tire squash.

Bucket Type			4.25 Meter Linkage — Tires: 35/65 R33 XLDD1 — SLR: 955 mm					
			General Purpose		Rock			
Ground Engaging Tools			Bolt-on Edges	Bolt-on Edges	Teeth & Segments	Teeth & Segments	Teeth & Segments	Teeth & Segments
Cutting Edge Type			Straight	Straight	Spade	Spade	Spade	Spade
Bucket Part No. (Group Level)			333-0931	333-0921	329-1611	333-0891	333-0911	333-0950
Struck capacity – ISO	m <sup>3</sup>		5.6	6.3	6.4	5.6	5.1	5.1
		yd <sup>3</sup>	7.3	8.2	8.4	7.3	6.7	6.7
Heaped capacity – ISO	m <sup>3</sup>		6.9	7.6	7.7	6.9	6.4	6.4
		yd <sup>3</sup>	9.0	10.0	10.0	9.0	8.3	8.3
Overall height	mm		8048	8152	8121	8018	7943	7944
		ft/in	26'5"	26'9"	26'8"	26'4"	26'1"	26'1"
Dump clearance at full lift and 45° discharge	With teeth	mm	—	—	3650	3728	3784	3758
		ft/in	—	—	12'0"	12'3"	12'5"	12'4"
	Bare	mm	4143	4059	3842	3920	3977	3926
		ft/in	13'7"	13'4"	12'7"	12'10"	13'1"	12'11"
Reach at full lift and 45° discharge	With teeth	mm	—	—	2329	2251	2194	2198
		ft/in	—	—	7'8"	7'5"	7'2"	7'3"
	Bare	mm	1852	1929	2145	2067	2011	2040
		ft/in	6'1"	6'4"	7'0"	6'9"	6'7"	6'8"
Reach level boom and level bucket	With teeth	mm	—	—	4862	4752	4672	4693
		ft/in	—	—	15'11"	15'7"	15'4"	15'5"
	Bare	mm	4176	4290	4596	4486	4406	4462
		ft/in	13'8"	14'1"	15'1"	14'9"	14'5"	14'8"
Digging depth	mm		258	263	264	264	264	279
		in	10	10	10	10	10	11
Overall length bucket level ground	mm		12 270	12 387	12 960	12 850	12 770	12 800
		ft/in	40'3"	40'8"	42'6"	42'2"	41'11"	42'0"
Turning radius — teeth corner SAE carry	mm		8870	8904	8983	8953	8931	8945
		ft/in	29'1"	29'3"	29'6"	29'4"	29'4"	29'4"
Reach at 45° dump and 2.13 m (7'0") height	With teeth	mm	—	—	3432	3387	3353	3346
		ft/in	—	—	11'3"	11'1"	11'0"	11'0"
	Bare	mm	3132	3184	3248	3203	3169	3188
		ft/in	10'3"	10'5"	10'8"	10'6"	10'5"	10'5"
Full dump at maximum lift	degrees		-48.5	-48.5	-48.5	-48.5	-48.5	-48.5
Static tipping load*, straight	kg		30 879	30 558	29 764	30 071	30 292	29 202
		lb	68,076	67,368	65,619	66,296	66,783	64,380
Static tipping load*, 35° turn	kg		26 422	26 099	25 325	25 633	25 855	24 765
		lb	58,251	57,539	55,831	56,512	56,999	54,598
Static tipping load*, full 43° turn	kg		24 432	24 110	23 344	23 651	23 873	22 785
		lb	53,864	53,153	51,465	52,142	52,631	50,231
Static tipping load**, straight	kg		32 262	31 951	31 143	31 441	31 654	30 559
		lb	71,126	70,440	68,659	69,316	69,785	67,371
Static tipping load**, 35° turn	kg		28 741	28 435	27 641	27 933	28 143	27 045
		lb	63,363	62,688	60,938	61,582	62,045	59,624
Static tipping load**, full 43° turn	kg		27 031	26 728	25 941	26 230	26 438	25 339
		lb	59,593	58,925	57,190	57,827	58,286	55,863
Breakout force — SAE rated	kg		52 971	49 652	42 469	44 873	46 770	44 969
		lb	116,780	109,465	93,628	98,928	103,110	99,139
Operating weight	kg		50 626	50 863	51 388	51 172	51 014	52 121
		lb	111,612	112,134	113,292	112,815	112,467	114,908
Weight distribution at SAE carry	Front	kg	25 652	26 093	27 145	26 736	26 438	28 473
		lb	56,522	57,524	59,844	58,943	58,286	62,772
	Rear	kg	24 975	24 771	24 243	24 436	24 576	23 648
		lb	55,060	54,610	53,447	53,872	54,181	52,135

Tire spec used for Tipping Load specifications includes 35-65R33 (L-4) Michelin XLDD1 tires.

\*Tipping Loads were calculated within guidelines of ISO 14397-1:2007 to include tire squash [Tire pressure at 634 kPa (92 psi)].

\*\*Tipping Load is calculated without tire squash.

		Standard						
		Spade HDLT	Spade BOCE	Spade HDLT & BOS	Spade HDLT & BOS	High Abrasion	HD Quarry	
<b>Bucket Type</b>								
<b>Bucket Part Number</b>		<b>8R5596</b>	<b>8R5599</b>	<b>155-4601</b>	<b>155-4603</b>	<b>202-7399</b>	<b>210-0247</b>	
Rated capacity	m <sup>3</sup> yd <sup>3</sup>	8.4 11.0	8.6 11.25	8.6 11.25	9.2 12.0	8.6 11.25	8.6 11.25	
Operating load at rated capacity	kg lb	15 000 33,069	15 000 33,069	15 000 33,069	15 000 33,069	15 000 33,069	15 000 33,069	
Heaped capacity	m <sup>3</sup> yd <sup>3</sup>	8.4 11.0	8.6 11.25	8.6 11.25	9.2 12.0	8.6 11.25	8.6 11.25	
Struck capacity	m <sup>3</sup> yd <sup>3</sup>	6.9 9.0	7.3 9.5	7.3 9.5	7.8 10.2	7.3 9.5	7.3 9.5	
Bucket width	mm ft/in	4450 14'7"	4450 14'7"	4450 14'7"	4610 15'2"	4574 15'0"	4450 14'7"	
Clearance at full lift, 45° dump	SAE	mm ft/in	4333 14'3"	4192 13'9"	4221 13'10"	4165 13'8"	4168 13'8"	
	Tooth tip	mm ft/in	4027 13'3"	N/A N/A	4024 13'2"	3968 13'0"	4018 13'2"	4023 13'2"
Reach at full lift, 45° dump	SAE	mm ft/in	1698 5'7"	1740 5'9"	1756 5'9"	1799 5'11"	1790 5'10"	1746 5'9"
	Tooth tip	mm ft/in	2223 7'4"	N/A N/A	2218 7'3"	2274 7'6"	2221 7'3"	2220 7'3"
Reach at 45° dump and 2130 mm (7'0") height	SAE	mm ft/in	2672 8'9"	2750 9'9"	2729 8'11"	2759 9'1"	2762 9'1"	2718 8'11"
	Tooth tip	mm ft/in	3196 10'6"	N/A N/A	3192 10'6"	3234 10'7"	3192 10'6"	3193 10'6"
Reach at level arm and level bucket	SAE	mm ft/in	3416 11'2"	3516 11'6"	3538 11'7"	3599 11'10"	3586 11'9"	3544 11'8"
	Tooth tip	mm ft/in	4202 13'9"	N/A N/A	4202 13'9"	4280 14'1"	4208 13'10"	4204 13'10"
Digging depth — bucket level	mm in	107 4	148 6	148 6	148 6	148 6	168 7	
Overall length	Edge	mm ft/in	12 341 40'6"	12 534 41'1"	12 492 41'0"	12 572 41'3"	12 568 41'3"	12 560 41'2"
	Tooth tip	mm ft/in	12 730 41'9"	N/A N/A	12 761 41'10"	12 839 42'1"	12 767 41'11"	12 778 41'11"
Overall height	mm ft/in	8091 26'7"	8091 26'7"	8091 26'7"	8091 26'7"	8091 26'7"	8091 26'7"	
Clearance circle at carry	Edge	mm ft/in	20 224 66'4"	20 527 67'4"	20 224 66'4"	20 290 66'7"	20 258 66'6"	20 227 66'4"
	Tooth tip	mm ft/in	20 674 67'10"	N/A N/A	20 674 67'10"	20 740 68'1"	20 708 67'11"	20 677 67'10"
Full dump at maximum lift	degrees	45	45	45	45	45	45	
Tipping load (at operating weight)	Straight	kg lb	43 997 96,996	43 242 95,331	42 873 94,518	42 392 93,457	41 347 91,154	43 516 95,935
	35° Articulated	kg lb	39 785 87,710	39 085 86,167	38 709 85,338	38 243 84,311	37 203 82,018	39 364 86,782
Breakout force		kN	655	602	610	584	581	598
		kg	66 760	61 430	62 210	59 509	59 271	61 006
		lb	147,179	135,429	137,148	131,194	130,669	134,494
Operating weight	kg lb	76 484 168,617	76 628 168,934	76 965 169,677	77 236 170,274	78 160 172,312	76 144 167,867	
Weight distribution	Front	kg lb	42 881 94,535	43 136 95,098	43 764 96,482	44 245 97,543	45 785 100,938	42 466 93,621
	Rear	kg lb	33 603 74,081	33 492 73,836	33 201 73,195	32 991 72,732	32 375 71,374	33 678 74,247
Shipping weight	kg lb	75 462 166,364	75 606 166,681	75 943 167,424	76 214 168,021	77 138 170,058	75 122 165,614	

HDLT = Heavy Duty Lug Teeth  
BOCE = Bolt-on Cutting Edge  
HDLT & BOS = Heavy Duty Lug Teeth and Bolt-on Segments  
HD = Heavy Duty

		High Lift					
		Spade HDLT	Spade BOCE	Spade HDLT & BOS	High Abrasion	HD Quarry	
<b>Bucket Type</b>							
<b>Bucket Part Number</b>		<b>8R5596</b>	<b>8R5599</b>	<b>155-4601</b>	<b>202-7399</b>	<b>210-0247</b>	
Rated capacity	m <sup>3</sup>	8.4	8.6	8.6	8.6	8.6	
	yd <sup>3</sup>	<b>11.0</b>	<b>11.25</b>	<b>11.25</b>	<b>11.25</b>	<b>11.25</b>	
Operating load at rated capacity	kg	15 000	15 000	15 000	15 000	15 000	
	lb	<b>33,069</b>	<b>33,069</b>	<b>33,069</b>	<b>33,069</b>	<b>33,069</b>	
Heaped capacity	m <sup>3</sup>	8.4	8.6	8.6	8.6	8.6	
	yd <sup>3</sup>	<b>11.0</b>	<b>11.25</b>	<b>11.25</b>	<b>11.25</b>	<b>11.25</b>	
Struck capacity	m <sup>3</sup>	6.9	7.3	7.3	7.3	7.3	
	yd <sup>3</sup>	<b>9.0</b>	<b>9.5</b>	<b>9.5</b>	<b>9.5</b>	<b>9.5</b>	
Bucket width	mm	4450	4450	4450	4574	4450	
	ft/in	<b>14'7"</b>	<b>14'7"</b>	<b>14'7"</b>	<b>15'0"</b>	<b>14'7"</b>	
Clearance at full lift, 45° dump	SAE	mm	4899	4758	4787	4734	4736
		ft/in	<b>16'1"</b>	<b>15'7"</b>	<b>15'8"</b>	<b>15'6"</b>	<b>15'6"</b>
	Tooth tip	mm	4593	N/A	4590	4584	4589
		ft/in	<b>15'1"</b>	<b>N/A</b>	<b>15'1"</b>	<b>15'0"</b>	<b>15'1"</b>
Reach at full lift, 45° dump	SAE	mm	1991	2033	2049	2083	2039
		ft/in	<b>6'6"</b>	<b>6'8"</b>	<b>6'9"</b>	<b>6'10"</b>	<b>6'8"</b>
	Tooth tip	mm	2516	N/A	2511	2514	2513
		ft/in	<b>8'3"</b>	<b>N/A</b>	<b>8'3"</b>	<b>8'3"</b>	<b>8'3"</b>
Reach at 45° dump and 2130 mm (7'0") height	SAE	mm	3286	3359	3343	3376	3333
		ft/in	<b>10'9"</b>	<b>11'0"</b>	<b>11'0"</b>	<b>11'1"</b>	<b>10'11"</b>
	Tooth tip	mm	3810	N/A	3806	3806	3807
		ft/in	<b>12'6"</b>	<b>N/A</b>	<b>12'6"</b>	<b>12'6"</b>	<b>12'6"</b>
Reach at level arm and level bucket	SAE	mm	4016	4116	4138	4186	4144
		ft/in	<b>13'2"</b>	<b>13'6"</b>	<b>13'7"</b>	<b>13'9"</b>	<b>13'7"</b>
	Tooth tip	mm	4802	N/A	4802	4808	4804
		ft/in	<b>15'9"</b>	<b>N/A</b>	<b>15'9"</b>	<b>15'9"</b>	<b>15'9"</b>
Digging depth — bucket level	mm	150	191	191	191	211	
	in	<b>6</b>	<b>8</b>	<b>8</b>	<b>8</b>	<b>8</b>	
Overall length	Edge	mm	13 080	13 273	13 231	13 307	13 299
		ft/in	<b>42'11"</b>	<b>43'7"</b>	<b>43'5"</b>	<b>43'8"</b>	<b>43'8"</b>
	Tooth tip	mm	13 469	N/A	13 500	13 506	13 517
		ft/in	<b>41'11"</b>	<b>N/A</b>	<b>44'3"</b>	<b>44'4"</b>	<b>44'4"</b>
Overall height	mm	8658	8658	8658	8658	8658	
	ft/in	<b>28'5"</b>	<b>28'5"</b>	<b>28'5"</b>	<b>28'5"</b>	<b>28'5"</b>	
Clearance circle at carry	Edge	mm	20 893	21 171	20 893	20 929	20 897
		ft/in	<b>68'7"</b>	<b>69'6"</b>	<b>69'7"</b>	<b>68'8"</b>	<b>68'7"</b>
	Tooth tip	mm	21 343	N/A	21 343	21 379	21 347
		ft/in	<b>70'0"</b>	<b>N/A</b>	<b>70'0"</b>	<b>70'2"</b>	<b>70'0"</b>
Full dump at maximum lift	degrees	<b>50</b>	<b>50</b>	<b>50</b>	<b>50</b>	<b>50</b>	
Tipping load (at operating weight)	Straight	kg	40 533	39 902	39 530	38 076	40 212
		lb	<b>89,359</b>	<b>87,968</b>	<b>87,148</b>	<b>83,942</b>	<b>88,651</b>
	35° Articulated	kg	36 227	35 644	35 267	33 831	35 959
		lb	<b>79,866</b>	<b>78,581</b>	<b>77,750</b>	<b>74,584</b>	<b>79,275</b>
Breakout force	kN	617	569	576	548	565	
	kg	62 947	57 977	58 694	55 891	57 611	
	lb	<b>138,773</b>	<b>127,816</b>	<b>129,397</b>	<b>123,217</b>	<b>127,009</b>	
Operating weight	kg	80 671	80 814	81 152	82 347	80 331	
	lb	<b>177,847</b>	<b>178,163</b>	<b>178,908</b>	<b>181,542</b>	<b>177,098</b>	
Weight distribution	Front	kg	44 177	44 456	45 141	47 366	43 705
		lb	<b>97,393</b>	<b>98,008</b>	<b>99,518</b>	<b>104,423</b>	<b>96,352</b>
	Rear	kg	36 494	36 358	36 011	34 981	36 626
		lb	<b>80,455</b>	<b>80,155</b>	<b>79,390</b>	<b>77,119</b>	<b>80,746</b>
Shipping weight	kg	79 649	79 792	80 130	81 325	79 309	
	lb	<b>175,594</b>	<b>175,909</b>	<b>176,655</b>	<b>179,289</b>	<b>174,845</b>	

HDLT = Heavy Duty Lug Teeth  
BOCE = Bolt-on Cutting Edge  
HDLT & BOS = Heavy Duty Lug Teeth and Bolt-on Segments  
HD = Heavy Duty

Bucket Type	Standard Lift							
	Rock			Heavy Duty Rock		High Abrasion Rock		
Ground Engaging Tools	Teeth & Segments	Teeth & Segments	Teeth & Segments	Teeth & Segments	Teeth & Segments	Teeth & Segments	Teeth & Segments	
Cutting Edge Type	Spade	Spade	Spade	Spade	Spade	Spade	Spade	
Rated bucket capacity (\$)	m <sup>3</sup> yd <sup>3</sup>	10.7 14.0	11.5 15.0	12.3 16.0	10.7 14.0	11.5 15.0	10.7 14.0	10.7 14.0
Operating load at rated capacity	kg lb	21 773 48,000	21 773 48,000	21 773 48,000	21 773 48,000	21 773 48,000	21 773 48,000	21 773 48,000
Struck capacity (\$)	m <sup>3</sup> yd <sup>3</sup>	8.9 11.6	9.5 12.4	10.2 13.3	8.9 11.6	9.5 12.4	8.9 11.6	8.9 11.6
Bucket width (\$)	mm ft/in	4824 15'10"	4884 16'0"	4824 15'10"	5068 16'7"	4824 15'10"	5165 16'11"	5068 16'7"
Dump clearance at full lift SAE 45° discharge (\$)	mm ft/in	4849 15'11"	4785 15'8"	4741 15'7"	4849 15'11"	4788 15'8"	4935 16'2"	4935 16'2"
	Tooth tip	mm ft/in	4607 15'1"	4548 14'11"	4495 14'8"	4612 15'1"	4545 14'11"	4699 15'5"
Reach at full lift SAE 45° discharge (\$)	mm ft/in	2092 6'11"	2149 7'0"	2194 7'2"	2092 6'11"	2151 7'11"	2036 6'10"	2036 6'10"
	Tooth tip	mm ft/in	2326 7'7"	2378 7'10"	2427 8'0"	2322 7'7"	2385 7'10"	2292 7'6"
Reach with boom horizontal and bucket level	mm ft/in	5114 16'10"	5193 17'0"	5265 17'4"	5108 16'10"	5200 17'1"	5025 16'6"	5025 16'6"
Digging depth (segment) (\$)	mm in	196 7.7	201 7.9	201 7.9	196 7.7	198 7.8	175 6.9	175 6.9
Overall length — bucket level ground (\$)	mm ft/in	15 736 51'7"	15 818 51'11"	15 890 51'11"	15 729 51'7"	15 823 51'11"	15 632 51'4"	15 632 51'4"
Overall height with bucket at full raise (\$)	mm ft/in	9313 30'7"	9313 30'7"	9492 31'1"	9313 30'7"	9313 30'7"	9392 30'10"	9313 30'7"
Loader clearance circle with bucket in carry position (\$)	mm ft/in	11 097 36'5"	11 121 36'6"	11 131 36'6"	11 096 36'5"	11 122 36'6"	11 085 36'5"	11 085 36'5"
Tipping load straight* (\$)	kg lb	55 216 121,730	54 526 120,209	54 184 119,455	53 745 118,487	54 784 120,778	51 692 113,961	53 325 117,561
Static tipping load full 35° turn* (\$)	kg lb	48 361 106,618	47 695 105,149	47 341 104,369	46 893 103,381	47 953 105,718	44 839 98,853	46 474 102,458
Static tipping load full 40° turn* (\$)	kg lb	46 440 102,383	45 780 100,928	45 422 100,138	44 972 99,146	46 037 101,494	42 919 94,620	44 554 98,225
Static tipping load full 43° turn* (\$)	kg lb	45 201 99,651	44 546 98,207	44 185 97,411	43 735 96,419	44 803 98,774	41 681 91,891	43 316 95,495
Tipping load straight** (\$)	kg lb	57 096 125,896	56 402 124,366	56 093 123,684	55 615 122,631	56 662 124,939	53 564 118,109	55 194 121,702
Static tipping load full 35° turn** (\$)	kg lb	51 328 113,178	50 653 111,691	50 338 110,995	49 847 109,912	50 913 112,264	47 796 105,39	49 426 108,984
Static tipping load full 40° turn** (\$)	kg lb	49 634 109,443	48 965 107,968	48 648 107,269	48 153 106,177	49 225 108,542	46 102 101,655	47 732 105,249
Static tipping load full 43° turn** (\$)	kg lb	48 527 107,003	47 863 105,537	47 544 104,835	47 047 103,738	48 123 —	44 996 99,216	46 625 102,809
Breakout force*** (\$)	kg lb	58 466 128,917	55 998 123,475	54 249 119,619	57 842 127,541	56 147 123,803	59 381 130,935	60 218 132,781
Operating weight**** (\$)	kg lb	97 295 214,535	97 688 215,402	98 068 215,750	98 674 217,576	97 469 214,919	100 844 222,361	99 050 218,405

\*Tipping loads were calculated within guidelines of ISO 14397-1:2007 to include tire squash (Tire pressure at 683 kPa [99 psi]).

\*\*Tipping load is calculated without tire squash.

\*\*\*Static tipping load and operating weight shown are based on standard machine configurations with a fuel tank, coolant, lubricants, and operator.

NOTE: Specifications and ratings conform to all applicable standards recommended by the Society for Automotive Engineers. SAE Standards J732C govern loader ratings and are denoted in the text by (\$).



Bucket Type	High Lift							
	Rock			Heavy Duty Rock		High Abrasion Rock		
Ground Engaging Tools		Teeth & Segments	Teeth & Segments	Teeth & Segments	Teeth & Segments	Teeth & Segments	Teeth & Segments	
Cutting Edge Type		Spade	Spade	Spade	Spade	Spade	Spade	
Rated bucket capacity (\$)	m <sup>3</sup> yd <sup>3</sup>	10.7 14.0	11.5 15.0	12.3 16.0	10.7 14.0	11.5 15.0	10.7 14.0	10.7 14.0
Operating load at rated capacity	kg lb	19 051 42,000	19 051 42,000	19 051 42,000	19 051 42,000	19 051 42,000	19 051 42,000	19 051 42,000
Struck capacity (\$)	m <sup>3</sup> yd <sup>3</sup>	8.9 11.6	9.5 12.4	10.2 13.3	8.9 11.6	9.5 12.4	8.9 11.6	8.9 11.6
Bucket width (\$)	mm ft/in	4824 15'10"	4884 16'0"	4824 15'10"	4884 16'7"	4824 15'10"	4900 16'11"	4900 16'7"
Dump clearance at full lift SAE 45° discharge (\$)	Tooth tip mm ft/in	5224 17'2"	5166 16'11"	5112 16'9"	5229 17'2"	5162 16'11"	5316 17'5"	5316 17'5"
Reach at full lift SAE 45° discharge (\$)	Tooth tip mm ft/in	2193 7'2"	2246 7'4"	2294 7'6"	2189 7'2"	2252 7'5"	2159 7'1"	2159 7'1"
Reach with boom horizontal and bucket level	mm ft/in	5504 18'1"	5583 18'4"	5655 18'7"	5498 18'0"	5590 18'4"	5415 17'9"	5415 17'9"
Digging depth (segment) (\$)	mm in	176 7.0	181 7.0	181 7.0	176 7.0	178 7.0	155 6.0	155 6.0
Overall length — bucket level ground (\$)	mm ft/in	16 197 53'2"	16 279 53'5"	16 351 53'8"	16 191 53'1"	16 284 53'5"	16 095 52'10"	16 095 52'10"
Overall height with bucket at full raise (\$)	mm ft/in	9930 32'7"	9930 32'7"	9930 32'7"	9930 32'7"	9930 32'7"	9930 32'7"	9930 32'7"
Loader clearance circle with bucket in carry position (\$)	mm ft/in	11 326 37'2"	11 352 37'3"	11 349 37'3"	11 324 37'3"	11 352 37'3"	11 313 37'1"	11 313 37'1"
Tipping load straight* (\$)	kg lb	51 408 113,335	50 761 111,909	50 436 111,192	49 938 110,094	51 017 112,473	47 875 105,546	49 522 109,177
Static tipping load full 35° turn* (\$)	kg lb	44 798 98,763	44 172 97,382	43 833 96,635	43 332 95,531	44 427 97,945	41 268 90,980	42 916 94,613
Static tipping load full 40° turn* (\$)	kg lb	42 946 94,680	42 325 93,311	41 981 92,552	41 481 91,450	42 580 93,873	39 417 86,900	41 065 90,533
Static tipping load full 43° turn* (\$)	kg lb	41 753 92,049	41 135 90,687	40 789 89,924	40 288 88,820	41 390 91,249	38 224 84,269	39 873 87,905
Tipping load straight** (\$)	kg lb	53 044 116,942	52 396 115,513	52 099 114,858	51 567 113,686	52 653 116,080	49 505 109,140	51 149 112,764
Static tipping load full 35° turn** (\$)	kg lb	47 472 104,658	46 840 103,264	46 535 102,592	45 994 101,399	47 097 103,831	43 932 96,853	45 577 100,480
Static tipping load full 40° turn** (\$)	kg lb	45 835 101,049	45 209 99,669	44 901 98,990	44 358 97,793	45 466 100,235	42 296 93,247	43 940 96,871
Static tipping load full 43° turn** (\$)	kg lb	44 766 98,692	44 143 97,319	43 834 96,637	43 289 95,436	44 400 97,885	41 227 90,890	42 871 94,514
Breakout force*** (\$)	kg lb	57 958 127,775	55 505 122,367	53 769 118,540	57 334 126,400	55 656 122,700	58 866 129,777	59 703 131,622
Operating weight*** (\$)	kg lb	99 076 218,425	99 469 219,291	99 849 220,129	100 455 221,465	99 250 218,809	102 625 226,249	100 831 222,294

\*Tipping loads were calculated within guidelines of ISO 14397-1:2007 to include tire squash (Tire pressure at 683 kPa [99 psi]).

\*\*Tipping load is calculated without tire squash.

\*\*\*Static tipping load and operating weight shown are based on standard machine configurations with a fuel tank, coolant, lubricants, and operator.

**NOTE:** Specifications and ratings conform to all applicable standards recommended by the Society for Automotive Engineers. SAE Standards J732C govern loader ratings and are denoted in the text by (\$).

Bucket Type	Tires 50/65R51 with Static Radius 1347 mm (4.4 ft)						
	Standard	High Lift	Standard	High Lift	Standard	High Lift	
	Rock		High Abrasion		Rock		
	Teeth & Segments	Teeth & Segments	Teeth & Segments	Teeth & Segments	Teeth & Segments	Teeth & Segments	
Ground Engaging Tools	Spade	Spade	Spade	Spade	Spade	Spade	
Cutting Edge Type	303-3270	303-3270	303-3310	303-3310	303-3260	303-3260	
Rated bucket capacity (\$)	m <sup>3</sup> yd <sup>3</sup>	12.8 16.7	12.8 16.7	12.8 16.7	12.8 16.7	12.0 15.7	12.0 15.7
Operating load at rated capacity	kg lb	27 216 60,000	24 948 55,000	27 216 60,000	24 948 55,000	27 216 60,000	24 948 55,000
Struck capacity (\$)	m <sup>3</sup> yd <sup>3</sup>	10.0 13.1	10.0 13.1	10.0 13.1	10.0 13.1	10.0 13.1	10.0 13.1
Heaped capacity (\$)	m <sup>3</sup> yd <sup>3</sup>	13.0 17.0	13.0 17.0	13.0 17.0	13.0 17.0	12.0 15.7	12.0 15.7
Bucket width (\$)	mm ft	5080 16.7	5080 16.7	5160 16.9	5160 16.9	5080 16.7	5080 16.7
Dump clearance at full lift SAE 45° discharge (\$)	mm ft	4654 15.3	5299 17.4	4721 15.5	5366 17.6	4744 15.6	5389 17.7
Reach at full lift 45° discharge tooth tip (\$)	mm ft	2503 8.2	2612 8.6	2507 8.2	2616 8.6	2413 7.9	2522 8.3
Reach with boom horizontal and bucket level	mm ft	4922 16.1	5438 17.8	4878 16.0	5394 17.7	4794 15.7	5310 17.4
Digging depth (segment) (\$)	mm in	246 9.7	313 12.3	231 9.1	298 11.7	246 9.7	313 12.3
Overall length — bucket level ground (\$)	mm ft	15 214 49.8	15 846 51.9	15 158 49.7	15 792 51.7	15 086 49.4	15 718 51.5
Reach at 45° dump and 2130 mm (7'0") height (W/T)	mm ft	3667 12.0	4189 13.7	3681 12.1	4202 13.8	3590 11.8	4111 13.5
Full dump at maximum lift	degrees	50.3	50.0	50.3	50.0	50.3	50.0
Tipping load straight (\$)	kg lb	84 789 186,959	71 202 157,001	84 101 185,444	70 571 155,609	85 197 187,859	71 635 157,955
Static tipping load, full 40° turn** (\$)	kg lb	73 591 162,268	61 346 135,268	72 928 160,807	60 734 133,918	74 015 163,203	61 791 136,249
Static tipping load, full 43° turn** (\$)	kg kg	71 931 158,607	59 885 132,046	71 271 157,153	59 275 130,702	72 357 159,547	60 331 133,031
Breakout force** (\$)	kN lb	709 159,390	708.3 159,232	729.8 164,066	729.1 163,908	754.1 169,528	753.4 169,371
Operating weight* (\$)	kg lb	133 190 293,018	134 156 295,143	133 626 293,977	134 592 296,102	132 730 292,006	133 696 294,131

\*Static tipping load and operating weight shown are based on standard machine configurations with a fuel tank, coolant, lubricants, and operator.

\*\*Measured 102 mm (4.0") behind tip of segments with bucket hinge pin as pivot point in accordance with SAE J732C.

**NOTE:** Specifications and ratings conform to all applicable standards recommended by the Society for Automotive Engineers. SAE Standards J732C govern loader ratings and are denoted in the text by (\$).

Bucket Type		Tires 50/65R51 with Static Radius 1347 mm (4.4 ft)					
		Standard	High Lift	Standard	High Lift	Standard	High Lift
		High Abrasion		Rock		Rock	
Ground Engaging Tools		Teeth & Segments	Teeth & Segments	Teeth & Segments	Teeth & Segments	Teeth & Segments	Teeth & Segments
Cutting Edge Type		Spade	Spade	Spade	Spade	Spade	Spade
Rated bucket capacity (\$)		303-3330	303-3330	303-3280	303-3280	303-3290	303-3290
Rated bucket capacity (\$)	m <sup>3</sup>	12.0	12.0	13.8	13.8	14.5	14.5
	yd <sup>3</sup>	15.7	15.7	18.0	18.0	19.0	19.0
Operating load at rated capacity	kg	27 216	24 948	27 216	24 948	27 216	24 948
	lb	60,000	55,000	60,000	55,000	60,000	55,000
Struck capacity (\$)	m <sup>3</sup>	10.0	10.0	11.0	11.0	12.0	12.0
	yd <sup>3</sup>	13.1	13.1	14.4	14.4	15.7	15.7
Heaped capacity (\$)	m <sup>3</sup>	12.0	12.0	14.0	14.0	14.0	14.0
	yd <sup>3</sup>	15.7	15.7	18.3	18.3	18.3	18.3
Bucket width (\$)	mm	5160	5160	5080	5080	5080	5080
	ft	16.9	16.9	16.7	16.7	16.7	16.7
Dump clearance at full lift SAE 45° discharge (\$)	mm	4769	5414	4555	5200	4555	5200
	ft	15.6	17.8	14.9	17.1	14.9	17.1
Reach at full lift 45° discharge tooth tip (\$)	mm	2459	2568	2602	2711	2602	2711
	ft	8.1	8.4	8.5	8.9	8.5	8.9
Reach with boom horizontal and bucket level	mm	4810	5326	5062	5578	5062	5578
	ft	15.8	17.4	16.6	18.3	16.6	18.3
Digging depth (segment) (\$)	mm	231	298	246	313	246	313
	in	9.1	11.7	9.7	12.3	9.7	12.3
Overall length — bucket level ground (\$)	mm	15 090	15 724	15 354	15 986	15 354	15 986
	ft	49.4	51.5	50.3	52.4	50.3	52.4
Reach at 45° dump and 2130 mm (7'0") height (W/T)	mm	3640	4160	3749	4273	3749	4273
	ft	11.9	13.6	12.3	14.0	12.3	14.0
Full dump at maximum lift	degrees	50.3	50.0	50.3	50.0	50.3	50.0
Tipping load straight (\$)	kg	84 654	71 092	81 591	68 155	81 757	68 223
	lb	186,662	156,759	179,909	150,283	180,275	150,433
Static tipping load, full 40° turn** (\$)	kg	73 468	61 245	70 469	58 357	70 588	58 390
	lb	161,998	135,046	155,384	128,678	155,647	128,750
Static tipping load, full 43° turn** (\$)	kg	71 810	59 785	68 819	56 905	68 932	56 932
	lb	158,341	131,827	151,747	125,475	151,996	125,535
Breakout force** (\$)	kN	756.7	755.9	660.8	660.2	659.3	658.7
	lb	170,113	169,933	148,554	148,419	148,217	148,082
Operating weight* (\$)	kg	133 238	134 204	135 789	136 755	136 018	136 984
	lb	293,124	295,249	298,736	300,861	299,240	301,365

\*Static tipping load and operating weight shown are based on standard machine configurations with a fuel tank, coolant, lubricants, and operator.

\*\*Measured 102 mm (4.0") behind tip of segments with bucket hinge pin as pivot point in accordance with SAE J732C.

**NOTE:** Specifications and ratings conform to all applicable standards recommended by the Society for Automotive Engineers. SAE Standards J732C govern loader ratings and are denoted in the text by (\$).

Bucket Type		Tires 50/65R51 with Static Radius 1368 mm (4.6 ft)					
		Standard	High Lift	Standard	High Lift	Standard	High Lift
		Rock		High Abrasion		Rock	
		Teeth & Segments	Teeth & Segments	Teeth & Segments	Teeth & Segments	Teeth & Segments	Teeth & Segments
Ground Engaging Tools		Spade	Spade	Spade	Spade	Spade	Spade
Cutting Edge Type		303-3270	303-3270	303-3310	303-3310	303-3260	303-3260
Rated bucket capacity (\$)	m <sup>3</sup>	12.8	12.8	12.8	12.8	12.0	12.0
	yd <sup>3</sup>	16.7	16.7	16.7	16.7	15.7	15.7
Operating load at rated capacity	kg	27 216	24 948	27 216	24 948	27 216	24 948
	lb	60,000	55,000	60,000	55,000	60,000	55,000
Struck capacity (\$)	m <sup>3</sup>	10.0	10.0	10.0	10.0	10.0	10.0
	yd <sup>3</sup>	13.1	13.1	13.1	13.1	13.1	13.1
Heaped capacity (\$)	m <sup>3</sup>	13.0	13.0	13.0	13.0	12.0	12.0
	yd <sup>3</sup>	17.0	17.0	17.0	17.0	15.7	15.7
Bucket width (\$)	mm	5080	5080	5160	5160	5080	5080
	ft	16.7	16.7	16.9	16.9	16.7	16.7
Dump clearance at full lift SAE 45° discharge (\$)	mm	4675	5320	4742	5387	4765	5410
	ft	15.3	17.5	15.6	17.7	15.6	17.8
Reach at full lift 45° discharge tooth tip (\$)	mm	2501	2610	2505	2614	2411	2520
	ft	8.2	8.6	8.2	8.6	7.9	8.3
Reach with boom horizontal and bucket level	mm	4920	5436	4876	5392	4792	5308
	ft	16.1	17.8	16.0	17.7	15.7	17.4
Digging depth (segment) (\$)	mm	225	292	210	277	225	292
	in	8.9	11.5	8.3	10.9	8.9	11.5
Overall length — bucket level ground (\$)	mm	15 198	15 832	15 142	15 778	15 070	15 704
	ft	49.8	51.9	49.6	51.7	49.4	51.4
Reach at 45° dump and 2130 mm (7'0") height (W/T)	mm	3668	4190	3682	4203	3591	4112
	ft	12.0	13.7	12.1	13.8	11.8	13.5
Full dump at maximum lift	degrees	50.3	50.0	50.3	50.0	50.3	50.0
Tipping load straight (\$)	kg	84 201	70 685	83 515	70 055	84 610	71 119
	lb	185,664	155,862	184,152	154,472	186,566	156,817
Static tipping load, full 40° turn** (\$)	kg	73 073	60 890	72 411	60 278	73 497	61 335
	lb	161,125	134,262	159,666	132,914	162,061	135,244
Static tipping load, full 43° turn** (\$)	kg	71 422	59 437	70 764	58 828	71 849	59 884
	lb	157,486	131,059	156,035	129,717	158,428	132,045
Breakout force** (\$)	kN	710.6	709.9	731.5	730.7	755.9	755.1
	lb	159,749	159,592	164,448	164,268	169,933	169,753
Operating weight* (\$)	kg	132 430	133 396	132 866	133 832	131 970	132 936
	lb	291,346	293,471	292,305	294,430	290,334	292,459

\*Static tipping load and operating weight shown are based on standard machine configurations with a fuel tank, coolant, lubricants, and operator.

\*\*Measured 102 mm (4.0") behind tip of segments with bucket hinge pin as pivot point in accordance with SAE J732C.

**NOTE:** Specifications and ratings conform to all applicable standards recommended by the Society for Automotive Engineers. SAE Standards J732C govern loader ratings and are denoted in the text by (\$).

Bucket Type		Tires 50/65R51 with Static Radius 1368 mm (4.6 ft)					
		Standard	High Lift	Standard	High Lift	Standard	High Lift
		High Abrasion		Rock		Rock	
		Teeth & Segments	Teeth & Segments	Teeth & Segments	Teeth & Segments	Teeth & Segments	Teeth & Segments
Ground Engaging Tools		Spade	Spade	Spade	Spade	Spade	Spade
Cutting Edge Type		303-3330	303-3330	303-3280	303-3280	303-3290	303-3290
Rated bucket capacity (\$)	m <sup>3</sup>	12.0	12.0	13.8	13.8	14.5	14.5
	yd <sup>3</sup>	15.7	15.7	18.0	18.0	19.0	19.0
Operating load at rated capacity	kg	27 216	24 948	27 216	24 948	27 216	24 948
	lb	60,000	55,000	60,000	55,000	60,000	55,000
Struck capacity (\$)	m <sup>3</sup>	10.0	10.0	11.0	11.0	12.0	12.0
	yd <sup>3</sup>	13.1	13.1	14.4	14.4	15.7	15.7
Heaped capacity (\$)	m <sup>3</sup>	12.0	12.0	14.0	14.0	14.0	14.0
	yd <sup>3</sup>	15.7	15.7	18.3	18.3	18.3	18.3
Bucket width (\$)	mm	5160	5160	5080	5080	5080	5080
	ft	16.9	16.9	16.7	16.7	16.7	16.7
Dump clearance at full lift SAE 45° discharge (\$)	mm	4790	5435	4576	5221	4576	5221
	ft	15.7	17.8	15.0	17.1	15.0	17.1
Reach at full lift 45° discharge tooth tip (\$)	mm	2457	2566	2600	2709	2600	2709
	ft	8.0	8.4	8.5	8.9	8.5	8.9
Reach with boom horizontal and bucket level	mm	4808	5324	5060	5576	5060	5576
	ft	15.8	17.4	16.6	18.3	16.6	18.3
Digging depth (segment) (\$)	mm	210	277	225	292	225	292
	in	8.3	10.9	8.9	11.5	8.9	11.5
Overall length — bucket level ground (\$)	mm	15 074	15 710	15 338	15 972	15 338	15 972
	ft	49.4	51.5	50.2	52.3	50.2	52.3
Reach at 45° dump and 2130 mm (7'0") height (W/T)	mm	3641	4161	3751	4274	3751	4274
	ft	11.9	13.6	12.3	14.0	12.3	14.0
Full dump at maximum lift	degrees	50.3	50.0	50.3	50.0	50.3	50.0
Tipping load straight (\$)	kg	84 067	70 576	81 008	67 642	81 172	67 708
	lb	185,369	155,620	178,623	149,150	178,984	149,296
Static tipping load, full 40° turn** (\$)	kg	72 950	60 789	69 954	57 904	70 071	57 934
	lb	160,856	134,041	154,248	127,678	154,507	127,746
Static tipping load, full 43° turn** (\$)	kg	71 302	59 338	68 314	56 460	68 425	56 485
	lb	157,221	130,841	150,633	124,494	150,878	124,550
Breakout force** (\$)	kN	758.5	757.6	662.4	661.7	660.9	660.2
	lb	170,518	170,315	148,913	148,756	148,576	148,419
Operating weight* (\$)	kg	132 478	133 444	135 029	135 995	135 258	136 224
	lb	291,452	293,577	297,064	299,189	297,568	299,693

\*Static tipping load and operating weight shown are based on standard machine configurations with a fuel tank, coolant, lubricants, and operator.

\*\*Measured 102 mm (4.0") behind tip of segments with bucket hinge pin as pivot point in accordance with SAE J732C.

**NOTE:** Specifications and ratings conform to all applicable standards recommended by the Society for Automotive Engineers. SAE Standards J732C govern loader ratings and are denoted in the text by (\$).

Bucket Type	Tires 50/65-51 with Static Radius 1412 mm (4.8 ft)						
	Standard	High Lift	Standard	High Lift	Standard	High Lift	
	Rock		High Abrasion		Rock		
	Teeth & Segments	Teeth & Segments	Teeth & Segments	Teeth & Segments	Teeth & Segments	Teeth & Segments	
Ground Engaging Tools	Spade	Spade	Spade	Spade	Spade	Spade	
Cutting Edge Type	303-3270	303-3270	303-3310	303-3310	303-3260	303-3260	
Rated bucket capacity (\$)	m <sup>3</sup> yd <sup>3</sup>	12.8 16.7	12.8 16.7	12.8 16.7	12.8 16.7	12.0 15.7	12.0 15.7
Operating load at rated capacity	kg lb	27 216 60,000	24 948 55,000	27 216 60,000	24 948 55,000	27 216 60,000	24 948 55,000
Struck capacity (\$)	m <sup>3</sup> yd <sup>3</sup>	10.0 13.1	10.0 13.1	10.0 13.1	10.0 13.1	10.0 13.1	10.0 13.1
Heaped capacity (\$)	m <sup>3</sup> yd <sup>3</sup>	13.0 17.0	13.0 17.0	13.0 17.0	13.0 17.0	12.0 15.7	12.0 15.7
Bucket width (\$)	mm ft	5080 16.7	5080 16.7	5160 16.9	5160 16.9	5080 16.7	5080 16.7
Dump clearance at full lift SAE 45° discharge (\$)	mm ft	4719 15.5	5364 17.6	4786 15.7	5431 17.8	4809 15.8	5454 17.9
Reach at full lift 45° discharge tooth tip (\$)	mm ft	2503 8.2	2612 8.6	2507 8.2	2616 8.6	2413 7.9	2522 8.3
Reach with boom horizontal and bucket level	mm ft	4922 16.1	5438 17.8	4878 16.0	5394 17.7	4794 15.7	5310 17.4
Digging depth (segment) (\$)	mm in	181 7.1	248 9.8	166 6.5	233 9.2	181 7.1	248 9.8
Overall length — bucket level ground (\$)	mm ft	15 163 49.7	15 803 51.8	15 107 49.5	15 748 51.6	15 035 49.3	15 675 51.4
Reach at 45° dump and 2130 mm (7'0") height (W/T)	mm ft	3677 12.0	4198 13.8	3690 12.1	4211 13.8	3599 11.8	4119 13.5
Full dump at maximum lift	degrees	50.3	50.0	50.3	50.0	50.3	50.0
Tipping load straight (\$)	kg lb	84 789 186,959	71 202 157,001	84 101 185,444	70 571 155,609	85 197 187,859	71 635 157,955
Static tipping load, full 40° turn** (\$)	kg lb	73 591 162,268	61 346 135,268	72 928 160,807	60 734 133,918	74 015 163,203	61 791 136,249
Static tipping load, full 43° turn** (\$)	kg lb	71 931 158,607	59 885 132,046	71 271 157,153	59 275 130,702	72 357 159,547	60 331 133,031
Breakout force** (\$)	kN lb	714.1 160,536	713.1 160,311	735 165,235	734 165,010	759.5 170,742	758.5 170,518
Operating weight* (\$)	kg lb	133 190 293,018	134 156 295,143	133 626 293,977	134 502 295,904	132 730 292,006	133 696 294,131

\*Static tipping load and operating weight shown are based on standard machine configurations with a fuel tank, coolant, lubricants, and operator.

\*\*Measured 102 mm (4.0") behind tip of segments with bucket hinge pin as pivot point in accordance with SAE J732C.

**NOTE:** Specifications and ratings conform to all applicable standards recommended by the Society for Automotive Engineers. SAE Standards J732C govern loader ratings and are denoted in the text by (\$).

Bucket Type		Tires 50/65-51 with Static Radius 1412 mm (4.8 ft)					
		Standard	High Lift	Standard	High Lift	Standard	High Lift
		High Abrasion		Rock		Rock	
		Teeth & Segments	Teeth & Segments	Teeth & Segments	Teeth & Segments	Teeth & Segments	Teeth & Segments
Ground Engaging Tools		Spade	Spade	Spade	Spade	Spade	Spade
Cutting Edge Type		303-3330	303-3330	303-3280	303-3280	303-3290	303-3290
Rated bucket capacity (\$)	m <sup>3</sup>	12.0	12.0	13.8	13.8	14.5	14.5
	yd <sup>3</sup>	15.7	15.7	18.0	18.0	19.0	19.0
Operating load at rated capacity	kg	27 216	24 948	27 216	24 948	27 216	24 948
	lb	60,000	55,000	60,000	55,000	60,000	55,000
Struck capacity (\$)	m <sup>3</sup>	10.0	10.0	11.0	11.0	12.0	12.0
	yd <sup>3</sup>	13.1	13.1	14.4	14.4	15.7	15.7
Heaped capacity (\$)	m <sup>3</sup>	12.0	12.0	14.0	14.0	14.0	14.0
	yd <sup>3</sup>	15.7	15.7	18.3	18.3	18.3	18.3
Bucket width (\$)	mm	5160	5160	5080	5080	5080	5080
	ft	16.9	16.9	16.7	16.7	16.7	16.7
Dump clearance at full lift SAE 45° discharge (\$)	mm	4834	5479	4620	5265	4620	5265
	ft	15.9	18.0	15.2	17.3	15.2	17.3
Reach at full lift 45° discharge tooth tip (\$)	mm	2459	2568	2602	2711	2602	2711
	ft	8.1	8.4	8.5	8.9	8.5	8.9
Reach with boom horizontal and bucket level	mm	4810	5326	5062	5578	5062	5578
	ft	15.8	17.4	16.6	18.3	16.6	18.3
Digging depth (segment) (\$)	mm	166	233	181	248	181	248
	in	6.5	9.2	7.1	9.8	7.1	9.8
Overall length — bucket level ground (\$)	mm	15 039	15 680	15 303	15 943	15 303	15 943
	ft	49.3	51.4	50.1	52.2	50.1	52.2
Reach at 45° dump and 2130 mm (7'0") height (W/T)	mm	3649	4168	3760	4283	3760	4283
	ft	12.0	13.7	12.3	14.0	12.3	14.0
Full dump at maximum lift	degrees	50.3	50.0	50.3	50.0	50.3	50.0
Tipping load straight (\$)	kg	84 654	71 092	81 591	68 155	81 757	68 223
	lb	186,662	156,759	179,909	150,283	180,275	150,433
Static tipping load, full 40° turn** (\$)	kg	73 468	61 245	70 469	58 357	70 588	58 390
	lb	161,998	135,046	155,384	128,678	155,647	128,750
Static tipping load, full 43° turn** (\$)	kg	71 810	59 785	68 819	56 905	68 932	56 932
	lb	158,341	131,827	151,747	125,475	151,996	125,535
Breakout force** (\$)	kN	762.1	761	665.7	664.8	664.2	663.3
	lb	171,327	171,080	149,655	149,453	149,318	149,116
Operating weight* (\$)	kg	133 238	134 204	135 789	136 755	136 018	136 984
	lb	293,124	295,249	298,736	300,861	299,240	301,365

\*Static tipping load and operating weight shown are based on standard machine configurations with a fuel tank, coolant, lubricants, and operator.

\*\*Measured 102 mm (4.0") behind tip of segments with bucket hinge pin as pivot point in accordance with SAE J732C.

**NOTE:** Specifications and ratings conform to all applicable standards recommended by the Society for Automotive Engineers. SAE Standards J732C govern loader ratings and are denoted in the text by (\$).

		Spade Edge Rock Buckets with Teeth & Segment				High Lift
Rated bucket capacity (\$)	m <sup>3</sup>	14.0	15.0	17.0	19.0	Same
	yd <sup>3</sup>	<b>18.5</b>	<b>19.5</b>	<b>22.5</b>	<b>25.0</b>	<b>Same</b>
Struck capacity (\$)	m <sup>3</sup>	11.0	12.0	14.0	15.0	Same
	yd <sup>3</sup>	<b>14.4</b>	<b>15.7</b>	<b>18.3</b>	<b>19.6</b>	<b>Same</b>
Bucket width (\$)	mm	5640	5640	5640	5640	Same
	ft/in	<b>18'6"</b>	<b>18'6"</b>	<b>18'6"</b>	<b>18'6"</b>	<b>Same</b>
Dump clearance at full lift and 45° discharge (\$)	mm	5771	5771	5663	5556	+339
	ft/in	<b>18'11"</b>	<b>18'11"</b>	<b>18'7"</b>	<b>18'3"</b>	<b>+1'1"</b>
Reach at full lift and 45° discharge (\$)	mm	2071	2071	2160	2266	+561
	ft/in	<b>6'9"</b>	<b>6'9"</b>	<b>7'1"</b>	<b>7'5"</b>	<b>+1'10"</b>
Reach with lift arms horizontal and bucket level	mm	4916	4916	5056	5206	+640
	ft/in	<b>16'1"</b>	<b>16'1"</b>	<b>16'7"</b>	<b>17'0"</b>	<b>+2'1"</b>
Digging depth (\$)	mm	108	108	108	108	+15
	in	<b>4</b>	<b>4</b>	<b>4</b>	<b>4</b>	<b>+0.5</b>
Overall length (\$)	mm	16 604	16 604	16 744	16 894	+792
	ft/in	<b>54'6"</b>	<b>54'6"</b>	<b>54'11"</b>	<b>55'5"</b>	<b>+2'7"</b>
Overall height with bucket at full raise (\$)	mm	10 719	10 719	10 866	10 911	+339
	ft/in	<b>35'2"</b>	<b>35'2"</b>	<b>35'7"</b>	<b>35'2"</b>	<b>+1'1"</b>
Loader clearance circle with bucket in carry position (\$)	mm	25 336	25 336	25 408	25 484	+578
	ft/in	<b>83'1"</b>	<b>83'1"</b>	<b>83'4"</b>	<b>83'7"</b>	<b>+1'11"</b>
Static tipping load, straight** (\$)	kg	130 783	131 140	130 266	128 499	0.83
	lb	<b>288,327</b>	<b>289,114</b>	<b>287,187</b>	<b>283,192</b>	<b>0.83</b>
Static tipping load, full 40° turn** (\$)	kg	113 391	113 684	112 784	111 091	0.82
	lb	<b>250,188</b>	<b>250,835</b>	<b>248,849</b>	<b>245,113</b>	<b>0.82</b>
Breakout force*** (\$)	kN	1134	1133	1055	989	0.96
	lb	<b>254,993</b>	<b>254,709</b>	<b>237,173</b>	<b>222,336</b>	<b>0.96</b>
Operating weight** (\$)	kg	191 899	192 039	192 699	193 779	+2735
	lb	<b>423,064</b>	<b>423,828</b>	<b>424,828</b>	<b>427,209</b>	<b>+6030</b>

\*Dimensions are measured to the tip of the bucket teeth to provide accurate clearance data. SAE Standards specifies the cutting edge.

\*\*Static tipping load and operating weight shown are based on standard machine configuration with 53.5/85-57 tires, full fuel tank, coolant and lubricants.

\*\*\*Measured 102 mm (4") behind tip of cutting edge with bucket hinge pin as pivot point in accordance with SAE J732 JUN92.

†Factor multiplied by standard arrangement data to get high lift arrangement value.

**NOTE:** Specifications and ratings conform to all applicable standards recommended by the Society of Automotive Engineers (SAE). SAE Standards J732 JUN92 and J742 FEB85 govern loader ratings, denoted in the text by (\$).



# Wheel Loaders Integrated Toolcarriers

## Performance Data ● 994F with 6220 mm (20'5") Bucket

		Spade Edge Rock Buckets with Teeth & Segment		Straight Edge Coal Bucket	High Lift
Rated bucket capacity (\$)	m <sup>3</sup>	18.0	19.0	31.0	Same
	yd <sup>3</sup>	<b>23.5</b>	<b>25.0</b>	<b>41.0</b>	<b>Same</b>
Struck capacity (\$)	m <sup>3</sup>	14.5	15.0	27.0	Same
	yd <sup>3</sup>	<b>19.0</b>	<b>19.6</b>	<b>35.3</b>	<b>Same</b>
Bucket width (\$)	mm	6200	6200	6200	Same
	ft/in	<b>20'4"</b>	<b>20'4"</b>	<b>20'4"</b>	<b>Same</b>
Dump clearance at full lift and 45° discharge (\$)	mm	5663	5563	5635	+339
	ft/in	<b>18'7"</b>	<b>18'3"</b>	<b>18'6"</b>	<b>+1'1"</b>
Reach at full lift and 45° discharge (\$)	mm	2160	2278	2306	+561
	ft/in	<b>7'1"</b>	<b>7'6"</b>	<b>7'6"</b>	<b>+1'10"</b>
Reach with lift arms horizontal and bucket level	mm	5056	5210	5179	+640
	ft/in	<b>16'7"</b>	<b>17'1"</b>	<b>17'0"</b>	<b>+2'1"</b>
Digging depth (\$)	mm	108	108	63	+15
	in	<b>4</b>	<b>4</b>	<b>2</b>	<b>+0.5</b>
Overall length (\$)	mm	16 744	16 898	16 830	+792
	ft/in	<b>54'11"</b>	<b>55'5"</b>	<b>55'2"</b>	<b>+2'7"</b>
Overall height with bucket at full raise (\$)	mm	10 621	10 636	11 845	+339
	ft/in	<b>34'10"</b>	<b>34'11"</b>	<b>38'10"</b>	<b>+1'1"</b>
Loader clearance circle with bucket in carry position (\$)	mm	25 930	26 004	26 146	+560
	ft/in	<b>85'1"</b>	<b>84'4"</b>	<b>85'9"</b>	<b>1'10"</b>
Static tipping load, straight** (\$)	kg	127 909	126 522	129 295	0.83
	lb	<b>281,991</b>	<b>278,933</b>	<b>285,046</b>	<b>0.83</b>
Static tipping load, full 40° turn** (\$)	kg	110 539	109 241	111 719	0.82
	lb	<b>243,895</b>	<b>241,032</b>	<b>246,298</b>	<b>0.82</b>
Breakout force*** (\$)	kN	1060	995	974	0.96
	lb	<b>238,289</b>	<b>223,685</b>	<b>218,964</b>	<b>0.96</b>
Operating weight** (\$)	kg	193 999	194 729	195 169	+2735
	lb	<b>427,694</b>	<b>429,303</b>	<b>430,273</b>	<b>+6030</b>

\*Dimensions are measured to the tip of the bucket teeth to provide accurate clearance data. SAE Standards specifies the cutting edge.

\*\*Static tipping load and operating weight shown are based on standard machine configuration with 53.5/85-57 tires, full fuel tank, coolant and lubricants.

\*\*\*Measured 102 mm (4") behind tip of cutting edge with bucket hinge pin as pivot point in accordance with SAE J732 JUN92.

†Factor multiplied by standard arrangement data to get high lift arrangement value.

**NOTE:** Specifications and ratings conform to all applicable standards recommended by the Society of Automotive Engineers (SAE). SAE Standards J732 JUN92 and J742 FEB85 govern loader ratings, denoted in the text by (\$).

Machine Dimensions  
 ● 904H-908H  
 ● Vertical Coupler

Wheel Loaders  
 Integrated Toolcarriers

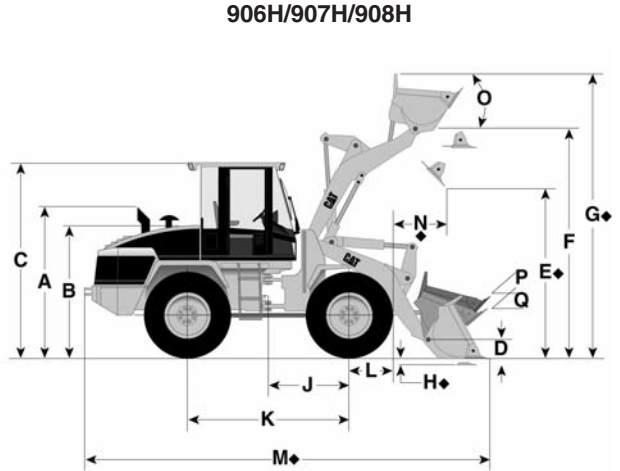
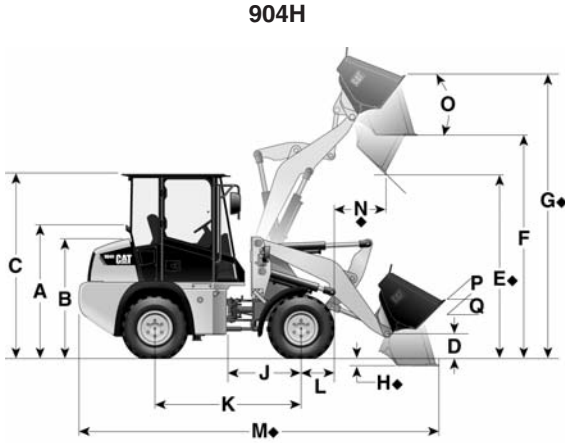

Dimensions shown represent standard machine with General Purpose bucket (bolt-on cutting edge) and standard tires.

◆ Varies with Bucket Size and/or Bucket Configuration — Refer to Performance Data

MODEL	904H General Purpose Bolt-on Edges 0.6 m <sup>3</sup> 0.8 yd <sup>3</sup>		906H General Purpose Bolt-on Edges 0.9 m <sup>3</sup> 1.17 yd <sup>3</sup>		907H General Purpose Bolt-on Edges 1.0 m <sup>3</sup> 1.31 yd <sup>3</sup>		908H General Purpose Bolt-on Edges 1.1 m <sup>3</sup> 1.48 yd <sup>3</sup>	
	A Height to top of stack	1714 mm	5'7"	2007 mm	6'7"	2007 mm	6'7"	2131 mm
B Height to top of engine compartment	1545 mm	5'1"	1645 mm	5'5"	1645 mm	5'5"	1710 mm	5'7"
C Height to top of ROPS	2378 mm	7'10"	2463 mm	8'1"	2586 mm	8'6"	2650 mm	8'8"
D Hinge pin height at carry position	135 mm	5"	114 mm	4"	114 mm	4"	181 mm	7"
◆E Dump clearance at full lift and 45° discharge angle	2343 mm	7'8"	2359 mm	7'9"	2359 mm	7'9"	2620 mm	8'7"
F Hinge pin height at full lift	3110 mm	10'2"	3227 mm	10'7"	3227 mm	10'7"	3410 mm	11'2"
◆G Maximum overall height	3996 mm	13'1"	4246 mm	13'11"	4246 mm	13'11"	4400 mm	14'5"
◆H Maximum digging depth	107 mm	4"	107 mm	4"	107 mm	4"	101 mm	4"
J Machine center point to axle	900 mm	3'0"	1085 mm	3'7"	1085 mm	3'7"	1085 mm	3'7"
K Wheel base	1900 mm	6'3"	2170 mm	7'1"	2170 mm	7'1"	2170 mm	7'1"
L Free radius of tire	418 mm	1'5"	513 mm	1'8"	513 mm	1'8"	547 mm	1'10"
◆M Maximum overall length	4693 mm	15'5"	5620 mm	18'5"	5620 mm	18'5"	5630 mm	18'6"
◆N Reach at full lift	677 mm	2'3"	820 mm	2'8"	820 mm	2'8"	866 mm	2'10"
O Maximum rollback at maximum lift	53.5°		52°		52°		49°	
P Maximum rollback at carry height	48°		52°		52°		52°	
Q Maximum rollback at ground	44.3°		47°		47°		47°	
Ground clearance (std. tires)	287 mm	11"	301 mm	12"	301 mm	12"	340 mm	13"
Tread width (std. tires)	1327 mm	4'4"	400 mm	1'4"	400 mm	1'4"	403 mm	1'4"
Width over tires (std. tires)	1642 mm	5'5"	1820 mm	6'0"	1820 mm	6'0"	1993 mm	6'6"
Tires used for measurements	12-16.5-10PR		405/70 R18		405/70 R18		405/70 R20	

# Wheel Loaders Integrated Toolcarriers

## Machine Dimensions

- 906H–914G
- Horizontal Coupler

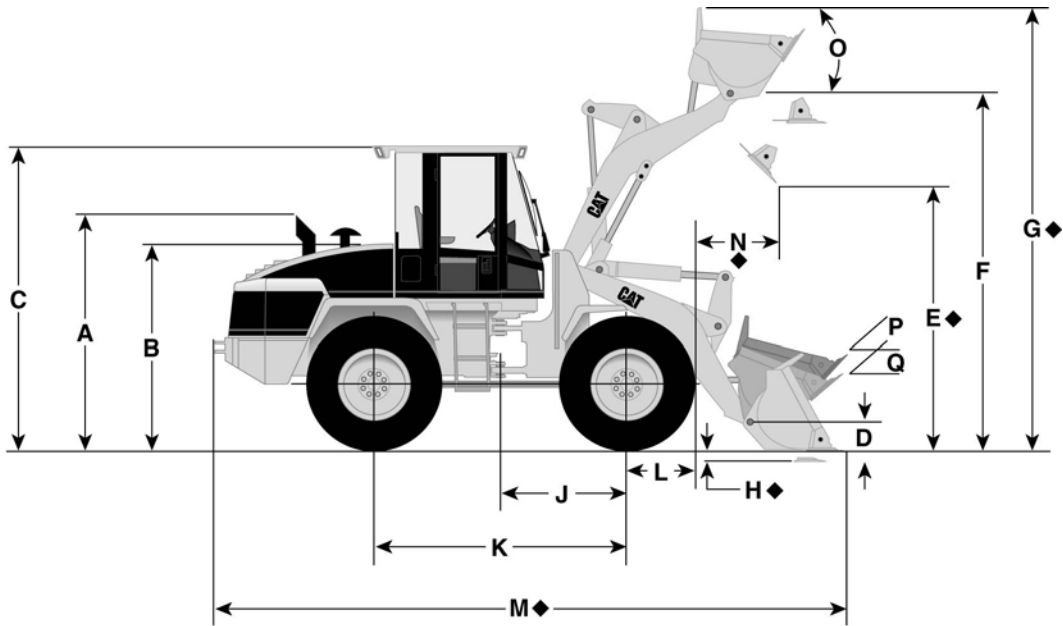

Dimensions shown represent standard machine with General Purpose bucket (bolt-on cutting edge) and standard tires.

◆ Varies with Bucket Size and/or Bucket Configuration — Refer to Performance Data

MODEL	906H		907H		908H		914G	
	General Purpose 0.9 m <sup>3</sup>	Bolt-on Edges 1.17 yd <sup>3</sup>	General Purpose 1.0 m <sup>3</sup>	Bolt-on Edges 1.31 yd <sup>3</sup>	General Purpose 1.1 m <sup>3</sup>	Bolt-on Edges 1.48 yd <sup>3</sup>	General Purpose 1.3 m <sup>3</sup>	Bolt-on Edges 1.7 yd <sup>3</sup>
A Height to top of stack	2007 mm	6'7"	2007 mm	6'7"	2131 mm	7'0"	2.26 m	7'5"
B Height to top of engine compartment	1645 mm	5'5"	1645 mm	5'5"	1710 mm	5'7"	2.08 m	6'10"
C Height to top of ROPS	2463 mm	8'1"	2586 mm	8'6"	2650 mm	8'8"	3.1 m	10'2"
D Hinge pin height at carry position	114 mm	4"	114 mm	4"	181 mm	7"	374 mm	15"
◆ E Dump clearance at full lift and 45° discharge angle	2478 mm	8'2"	2478 mm	8'2"	2620 mm	8'7"	2.66 m	8'9"
F Hinge pin height at full lift	3227 mm	10'7"	3227 mm	10'7"	3410 mm	11'2"	3.44 m	11'3"
◆ G Maximum overall height	4140 mm	13'7"	4140 mm	13'7"	4296 mm	14'1"	4.39 m	14'5"
◆ H Maximum digging depth	95 mm	4"	95 mm	4"	101 mm	4"	89 mm	3.5"
J Machine center point to axle	1085 mm	3'7"	1085 mm	3'7"	1085 mm	3'7"	1.3 m	4'3"
K Wheel base	2170 mm	7'1"	2170 mm	7'1"	2170 mm	7'1"	2.6 m	8'6"
L Free radius of tire	513 mm	1'8"	513 mm	1'8"	547 mm	1'10"	670 mm	26"
◆ M Maximum overall length	5469 mm	17'11"	5469 mm	17'11"	5630 mm	18'6"	6.23 m	20'5"
◆ N Reach at full lift	725 mm	2'5"	725 mm	2'5"	770 mm	2'6"	973 mm	3'2"
O Maximum rollback at maximum lift		52°		52°		49°		60°
P Maximum rollback at carry height		52°		52°		52°		46°
Q Maximum rollback at ground		47°		47°		47°		41°
Ground clearance (std. tires)	301 mm	12"	301 mm	12"	340 mm	13"	456 mm	18"
Tread width (std. tires)	400 mm	1'4"	400 mm	1'4"	403 mm	1'4"	1.8 m	5'10.9"
Width over tires (std. tires)	1820 mm	6'0"	1820 mm	6'0"	1993 mm	6'6"	2.26 m	7'4.9"
Tires used for measurements	405/70 R18		405/70 R18		405/70 R20		17.5-R25 (L-2)	

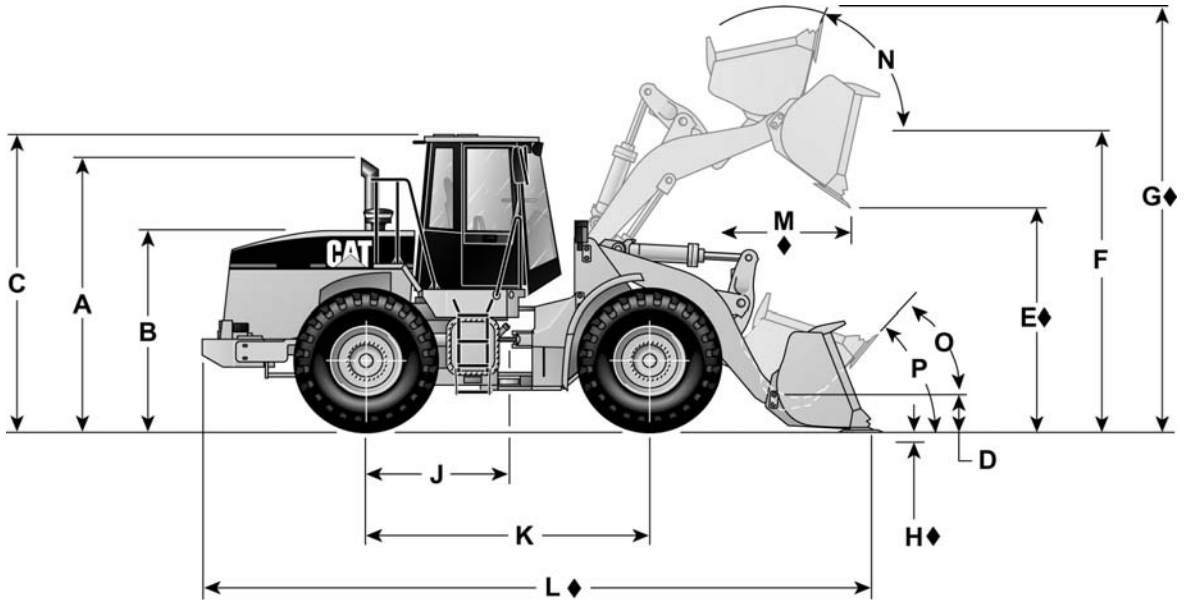

Dimensions shown represent standard machine with bucket, bolt-on cutting edge, and standard tires.

◆ Varies with Bucket Size and/or Bucket Configuration — Refer to Performance Data.

MODEL	924Hz*	
	1.8 m <sup>3</sup>	2.3 yd <sup>3</sup>
A Height to top of exhaust stack	3211 mm	10'7"
B Height to top of hood	2219 mm	7'4"
C Height to top of ROPS/FOPS	3227 mm	10'7"
D Carry height	435 mm	17"
◆ E Dump clearance at maximum lift and 45° dump	3432 mm	11'3"
F Bucket pin height at maximum lift	3757 mm	12'4"
◆ G Overall height — bucket raised	4809 mm	15'9"
◆ H Digging depth	42 mm	1.7"
J Center line of front axle to hitch	1400 mm	4'7"
K Wheel base length	2800 mm	9'2"
◆ L Maximum overall length	6898 mm	22'8"
◆ M Reach at maximum lift and 45° dump	791 mm	2'7"
N Rack back angle at maximum lift		58°
O Rack back angle at carry		48°
P Rack back angle at ground		44°
Height to center of axle	692 mm	2'4"
Ground clearance	436 mm	1'5"
Length — rear axle to bumper	1962 mm	6'5"
Bucket clearance at maximum lift and level	3434 mm	11'4"
Dump angle at maximum lift		45°
Tires used for measurements	20.5R25 (L-3)	

\*Loose Material buckets with bolt-on edges.

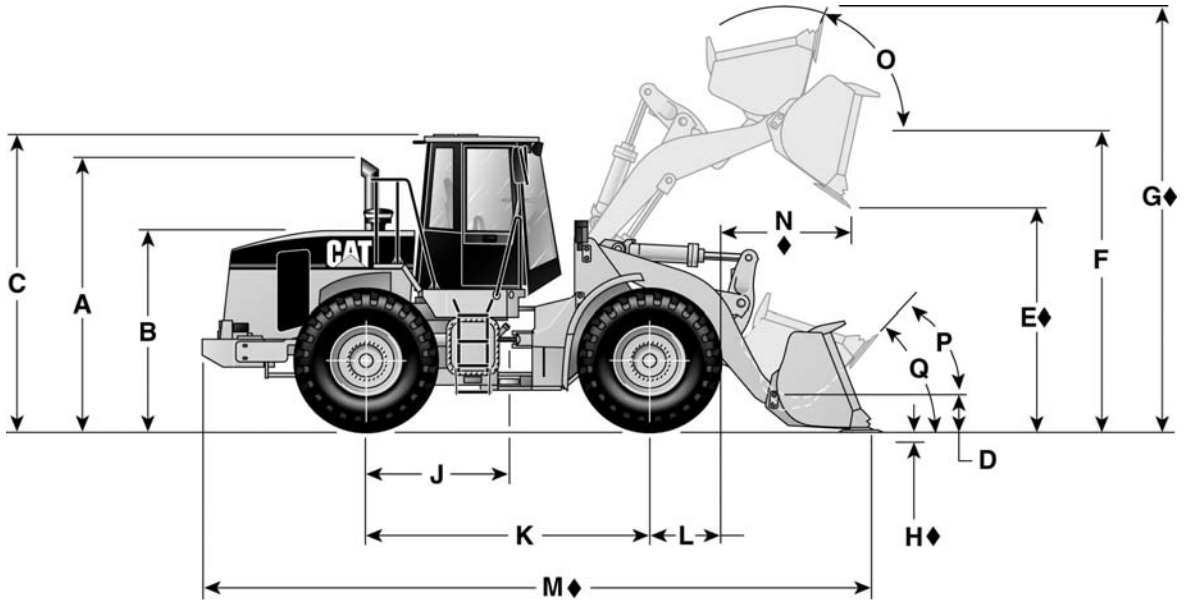

Dimensions shown represent standard machine with bucket, bolt-on cutting edge, and standard tires.

◆ Varies with Bucket Size and/or Bucket Configuration — Refer to Performance Data.

MODEL	928Hz General Purpose Bolt-on Edges		938H General Purpose Bolt-on Edges	
	2.3 m <sup>3</sup>	3.0 yd <sup>3</sup>	2.8 m <sup>3</sup>	3.65 yd <sup>3</sup>
A Height to top of stack	3.19 m	10'6"	3099 mm	10'2"
B Height to top of engine compartment	2.20 m	7'3"	2415 mm	7'11"
C Height to top of ROPS	3.27 m	10'8"	3356 mm	11'0"
D Hinge pin height at carry position	449 mm	18"	539 mm	21"
◆ E Dump clearance at full lift and 45° discharge angle	2.88 m	9'5"	2.77 m	9'1"
F Hinge pin height at full lift	3.87 m	12'8"	3.84 m	12'7"
◆ G Maximum overall height	4.97 m	16'4"	5.28 m	17'4"
◆ H Maximum digging depth	86 mm	3.4"	50 mm	1.9"
J Machine center point to axle	1.45 m	4'9"	1.51 m	4'11"
K Wheel base	2.90 m	9'6"	3.02 m	9'11"
L Radius of tire	685 mm	27"	741 mm	2'5"
◆ M Maximum overall length	7.25 m	23'10"	7343 mm	24'1"
◆ N Reach at full lift	927 mm	3'0"	1077 mm	3'10"
O Maximum rollback at maximum lift		60°		65°
P Maximum rollback at carry height		48°		50°
Q Maximum rollback at ground		44°		44°
Ground clearance (std. tires)	408 mm	16"	397 mm	15"
Tread width (std. tires)	1.95 m	6'5"	2.02 m	6'8"
Width over tires (std. tires)	2.41 m	7'11"	2674 mm	8'9"
Length — rear axle to bumper	1.92 m	6'4"	1869 mm	6'1"
Bucket clearance at maximum lift and level	3.75 m	12'4"	—	—
Dump angle at maximum lift		45°		50°
Tires used for measurements		17.5-25 12PR (L-2)		20.5R25 (L-3)

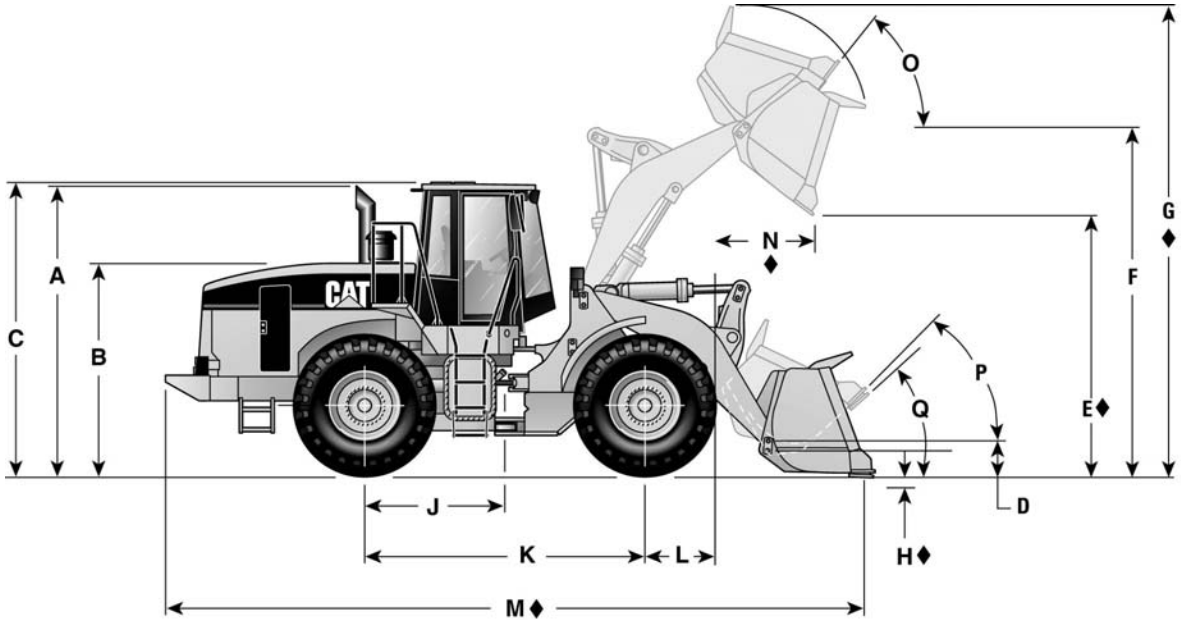

Dimensions shown represent standard machine with bucket, bolt-on cutting edge, and standard tires.

◆ Varies with Bucket Size and/or Bucket Configuration — Refer to Performance Data.

MODEL	950H General Purpose Bolt-on Edges 3.1 m <sup>3</sup> 4 yd <sup>3</sup>		962H General Purpose Bolt-on Edges 3.5 m <sup>3</sup> 4.5 yd <sup>3</sup>		966H General Purpose Bolt-on Edges 3.8 m <sup>3</sup> 5 yd <sup>3</sup>		972H General Purpose Bolt-on Edges 4.3 m <sup>3</sup> 5.5 yd <sup>3</sup>	
	A Height to top of exhaust pipe	3.37 m	11'1"	3.37 m	11'1"	3.55 m	11'8"	3.56 m
B Height to top of engine compartment	2.46 m	8'1"	2.46 m	8'1"	2.68 m	8'9"	2.68 m	8'9"
C Height to top of ROPS	3.45 m	11'4"	3.45 m	11'4"	3.60 m	11'10"	3.61 m	11'10"
D Hinge pin height at carry position	455 mm	18"	643 mm	25"	507 mm	20"	507 mm	20"
◆E Dump clearance at full lift and 45° discharge angle	2.92 m	9'7"	3.00 m	9'10"	3.12 m	10'3"	3.31 m	10'10"
F Hinge pin height at full lift	3.99 m	13'1"	4.18 m	13'8"	4.24 m	13'10"	4.47 m	14'8"
◆G Maximum overall height	5.44 m	17'10"	5.57 m	18'3"	5.81 m	19'1"	6.07 m	19'11"
◆H Maximum digging depth	92 mm	3.6"	92 mm	3.6"	108 mm	4.25"	88 mm	3.5"
J Machine center point to axle	1.68 m	5'6"	1.68 m	5'6"	1.72 m	5'8"	1.73 m	5'8"
K Wheel base	3.35 m	11'0"	3.35 m	11'0"	3.45 m	11'4"	3.45 m	11'4"
L Radius of tire	835 mm	33"	835 mm	33"	903 mm	36"	903 mm	36"
◆M Maximum overall length	7.99 m	26'2"	8.34 m	27'4"	8.81 m	28'11"	9.07 m	29'9"
◆N Reach at full lift	1202 mm	3'11"	1257 mm	4'1"	1270 mm	4'2"	1246 mm	4'1"
O Maximum rollback at maximum lift		59°		59°		61°		55°
P Maximum rollback at carry height		45°		48°		47°		47°
Q Maximum rollback at ground		39°		40°		42°		41°
Ground clearance (std. tires)	412 mm	16"	412 mm	16"	496 mm	20"	496 mm	20"
Tread width (std. tires)	2.14 m	7'0"	2.14 m	7'0"	2.23 m	7'4"	2.23 m	7'4"
Width over tires (std. tires)	2.78 m	9'1"	2.78 m	9'1"	3.00 m	9'10"	3.00 m	9'10"
Tires used for measurements	23.5-R25, XHA (L-3)		23.5-R25, XHA (L-3)		26.5-R25, SRG (L-4)		26.5-R25, SRG (L-4)	

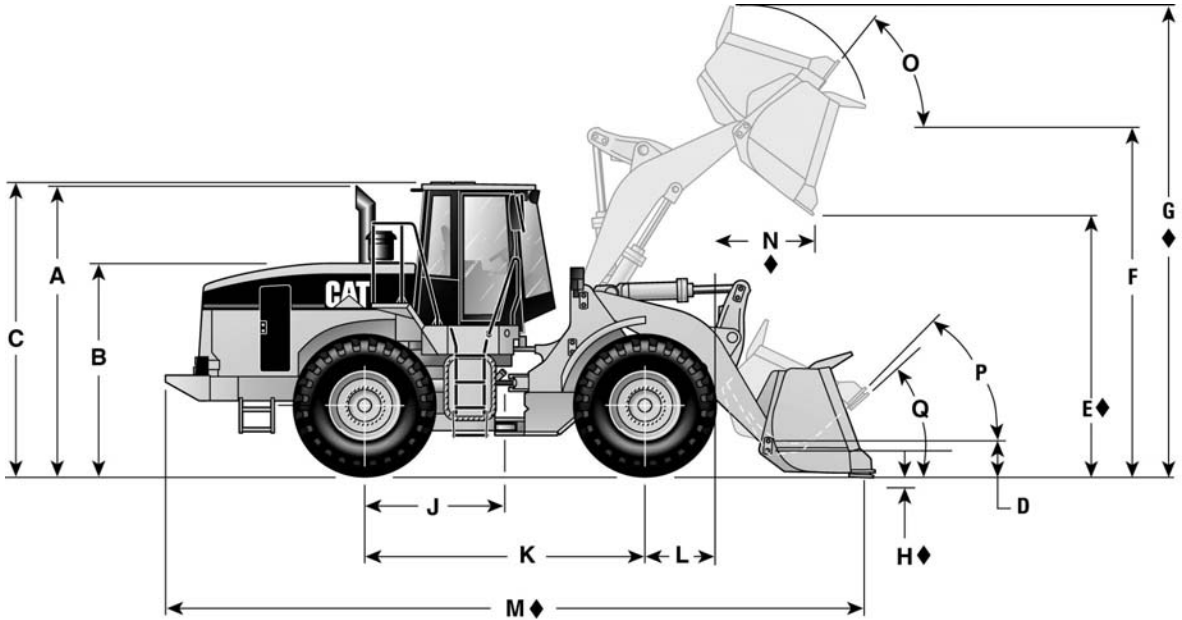

Dimensions shown represent standard machine with spade edge rock bucket and standard tires.

◆ Varies with Bucket Size and/or Bucket Configuration — Refer to Performance Data.

MODEL	980H General Purpose Bolt-on Edges		980H General Purpose High Lift Bolt-on Edges	
	5.7 m <sup>3</sup>	7.5 yd <sup>3</sup>	5.7 m <sup>3</sup>	7.5 yd <sup>3</sup>
A Height to top of stack	3.72 m	12'2"	3.72 m	12'2"
B Height to top of engine compartment	2.72 m	8'11"	2.72 m	8'11"
C Height to top of ROPS	3.77 m	12'4"	3.77 m	12'4"
D Hinge pin height at carry position	453 mm	18"	453 mm	18"
◆ E Dump clearance at full lift and 45° discharge angle	3.27 m	10'9"	3.49 m	11'6"
F Hinge pin height at full lift	4.50 m	14'9"	4.73 m	15'6"
◆ G Maximum overall height	6.36 m	20'10"	6.58 m	21'7"
◆ H Maximum digging depth	125 mm	5"	123 mm	4.8"
J Machine center point to axle	1.85 m	6'1"	1.85 m	6'1"
K Wheel base	3.70 m	12'2"	3.70 m	12'2"
L Radius of tire	867 mm	2'10"	928 mm	3'1"
◆ M Maximum overall length	9.47 m	31'1"	9.68 m	31'9"
◆ N Reach at full lift	1.53 m	5'0"	1.53 m	5'0"
O Maximum rollback at maximum lift		61°		61°
P Maximum rollback at carry height		49°		49°
Q Maximum rollback at ground		41°		41°
Ground clearance (std. tires)	442 mm	17.4"	442 mm	17.4"
Tread width (std. tires)	2.44 m	8'0"	2.44 m	8'0"
Width over tires (std. tires)	3.25 m	10'8"	3.25 m	10'8"
Tires used for measurements	29.5-R25 (L-3)		29.5-R25 (L-3)	

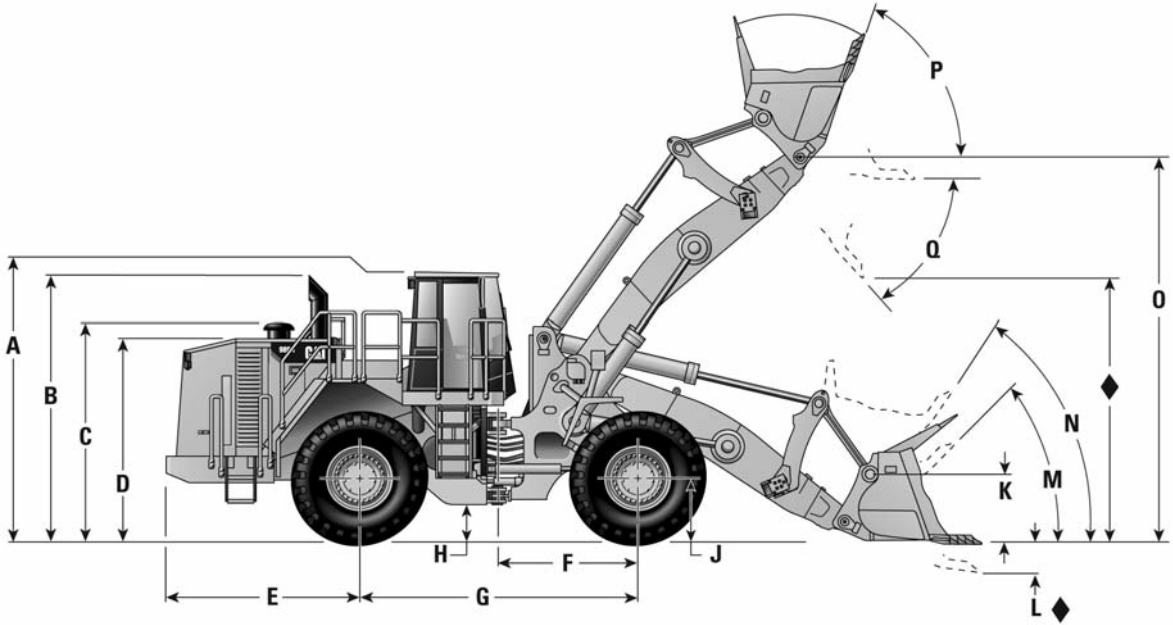

4.25 Meter Linkage

◆ Dimensions vary with bucket. Refer to Operation/Bucket Specifications.

MODEL	988H BXY4000-UP	
A A Height to top of cab	4105 mm	13.47 ft
B Height to top of exhaust stack	4089 mm	13.42 ft
C Height to top of air cleaner	3359 mm	11.02 ft
D Height to top of hood	3133 mm	10.28 ft
E Center line of rear axle to edge of rear bumper	3132 mm	10.28 ft
F Center line of front axle to hitch	2275 mm	7.46 ft
G Wheel base length	4550 mm	14.93 ft
H Ground clearance	526 mm	1.73 ft
J Height to center of wheel	955 mm	3.13 ft
K C-pin height**	1157 mm	3.8 ft
L Dig depth	264 mm	10 in
	232 mm*	9 in*
M Rack back angle at ground		47.8°
		45.7°*
N Rack back angle at carry		58.7°
		54.5°*
O B-pin height	5830 mm	19.13 ft
	5417 mm*	17.77 ft*
P Rack back angle at maximum lift		73°
Q Dump angle at maximum lift		48.5°
		51.4°*

\*3.88 Meter Linkage.

\*\*Same for both 3.88 and 4.25 Meter Linkage.



**Wheel Loaders  
Integrated Toolcarriers**

**Machine Dimensions**

- 988H BXY4000-UP
- Tire Dimensions/Specifications

<b>Tire Dimensions/Specifications</b>	<b>Width over Tires</b>		<b>Ground Clearance</b>		<b>Change in Vertical Dimensions</b>		<b>Change in Full Turn Static Tipping Load</b>	
	<b>mm</b>	<b>in</b>	<b>mm</b>	<b>in</b>	<b>mm</b>	<b>in</b>	<b>kg</b>	<b>lb</b>
35/65R33 (L-4) Michelin XLDD1	3598	<b>140.1</b>	526	<b>20.7</b>	0	<b>0</b>	0	<b>0</b>
35/65-33 42 PR (L-5) Bridgestone D-Lug	3541	<b>139.4</b>	565	<b>22.2</b>	39	<b>1.5</b>	1855	<b>4090</b>
35/65R33 (L-4) Bridgestone V-Steel N Traction VSNT	3569	<b>140.5</b>	541	<b>21.3</b>	15	<b>0.6</b>	287	<b>633</b>
35/65R33 (L-5) Bridgestone V-Steel D-Lug VSDL	3540	<b>139.4</b>	541	<b>21.3</b>	15	<b>0.6</b>	911	<b>2008</b>
35/65-33 42PR (L-5) Goodyear NRL D/L 5A	3487	<b>137.3</b>	553	<b>21.8</b>	27	<b>1.1</b>	2144	<b>4727</b>
875/65R33 (L-5) RL-5K	3536	<b>139.2</b>	543	<b>21.4</b>	17	<b>0.7</b>	1036	<b>2284</b>
35/65R33 (L-5) Michelin XLDD2	3549	<b>139.7</b>	536	<b>21.1</b>	10	<b>0.4</b>	242	<b>534</b>

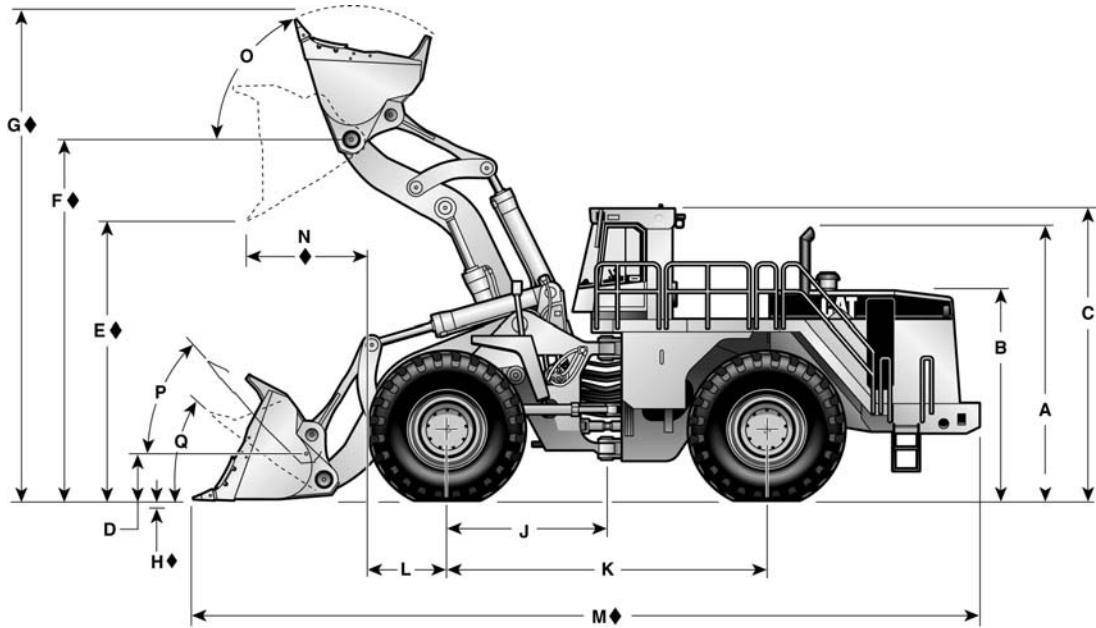

Dimensions shown represent standard machine with spade edge rock bucket and standard tires.

◆ Varies with Bucket Size and/or Bucket Configuration — Refer to Performance Data

MODEL	990H Spade Edge Rock with Teeth		990H High Lift Spade Edge Rock with Teeth		992K Spade Edge Rock with Teeth		992K High Lift Spade Edge Rock with Teeth	
	8.6 m <sup>3</sup>	11.2 yd <sup>3</sup>	8.6 m <sup>3</sup>	11.2 yd <sup>3</sup>	12.3 m <sup>3</sup>	16.0 yd <sup>3</sup>	10.7 m <sup>3</sup>	14 yd <sup>3</sup>
A Height to top of stack	4.76 m	15'7"	4.76 m	15'7"	5.24 m	17'2"	5.24 m	17'2"
B Height to top of engine compartment	3.55 m	11'8"	3.55 m	11'8"	4.0 m	13'1"	4.0 m	13'1"
C Height to top of ROPS	5.11 m	16'9"	5.11 m	16'9"	5.67 m	18'7"	5.67 m	18'7"
D Hinge pin height at carry position	816 mm	2'8"	862 mm	2'10"	1209 mm	4'0"	1339 mm	4'5"
◆ E Dump clearance at full lift and 45° discharge angle	4.22 m	13'10"	4.59 m	15'1"	4.49 m	14'9"	5.22 m	17'2"
◆ F Hinge pin height at full lift	5.87 m	19'3"	6.43 m	21'1"	6.92 m	22'8"	7.54 m	24'9"
◆ G Maximum overall height	8.09 m	26'7"	8.66 m	28'5"	9.49 m	31'2"	9.93 m	32'7"
◆ H Maximum digging depth	148 mm	6"	191 mm	8"	201 mm	8"	176 mm	7"
J Machine center point to axle	2.3 m	7'7"	2.3 m	7'7"	2.94 m	9'8"	2.94 m	9'8"
K Wheel base	4.6 m	15'1"	4.6 m	15'1"	5.89 m	19'4"	5.89 m	19'4"
L Radius of tire	1.18 m	3'11"	1.18 m	3'11"	1.37 m	4'6"	1.37 m	4'6"
◆ M Maximum overall length	12.8 m	42'0"	13.5 m	44'3"	15.9 m	52'2"	19.2 m	63'0"
◆ N Reach at full lift	2.22 m	7'3"	2.51 m	8'3"	2.43 m	8'0"	2.19 m	7'2"
O Maximum rollback at maximum lift	63.8°		60.6°		65°		65°	
P Maximum rollback at carry height	48.4°		47.4°		52.7°		52.5°	
Q Maximum rollback at ground	39.1°		38.9°		43.4°		42.8°	
Ground clearance (std. tires)	478 mm	18.8"	478 mm	18.8"	682 mm	26.8"	682 mm	26.8"
Tread width (std. tires)	3.05 m	10'0"	3.05 m	10'0"	3.30 m	10'10"	3.30 m	10'10"
Width over tires (std. tires)	4.16 m	13'3"	4.16 m	13'3"	4.50 m	14'9"	4.50 m	14'9"
Tires used for measurements	41.25/70-39 (L-5)		41.25/70-39 (L-5)		—		—	

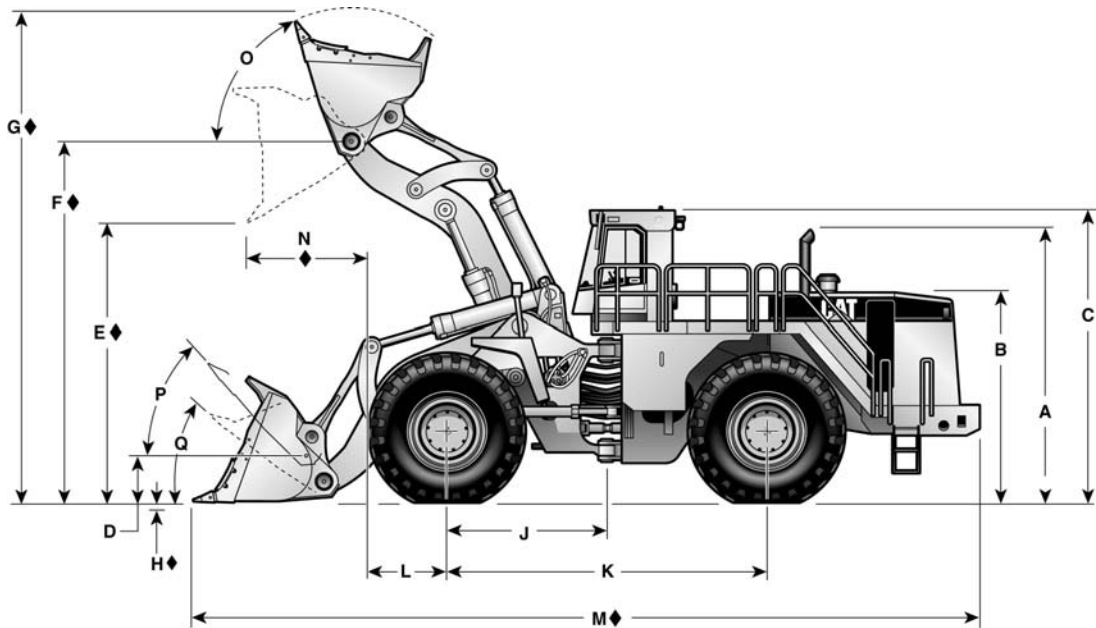

Dimensions shown represent standard machine with spade edge rock bucket and standard tires.

◆ Varies with Bucket Size and/or Bucket Configuration — Refer to Performance Data

MODEL	993K Standard Lift Spade Edge Rock with Teeth & Segments		993K High Lift Spade Edge Rock with Teeth & Segments	
	13 m <sup>3</sup>	17 yd <sup>3</sup>	13 m <sup>3</sup>	17 yd <sup>3</sup>
A Height to top of stack	5.45 m	17'9"	5.45 m	17'9"
B Height to top of engine compartment	4.25 m	14'0"	4.25 m	14'0"
C Height to top of ROPS	6.00 m	19'7"	6.00 m	19'7"
D Hinge pin height at carry position	1009 mm	39.7"	1185 mm	46.7"
◆ E Dump clearance at full lift and 45° discharge angle	4.65 m	15'3"	5.29 m	17'4"
F Hinge pin height at full lift	7.00 m	23'0"	7.64 m	25'1"
◆ G Maximum overall height	9.79 m	32'1"	10.43 m	34'0"
◆ H Maximum digging depth	181 mm	7"	246 mm	10"
J Machine center point to axle	2.94 m	9'8"	2.94 m	9'8"
K Wheel base	5.89 m	19'4"	5.89 m	19'4"
L Radius of tire	1.34 m	4'4"	1.34 m	4'4"
◆ M Maximum overall length	15.21 m	50'0"	15.84 m	52'0"
◆ N Reach at full lift	2.50 m	8'2"	2.61 m	8'6"
O Maximum rollback at maximum lift		63.9°		65.7°
P Maximum rollback at carry height		52.5°		53.5°
Q Maximum rollback at ground		46.3°		46.1°
Ground clearance (std. tires)	590 mm	2'0"	590 mm	2'0"
Tread width (std. tires)	3.54 m	11'6"	3.54 m	11'6"
Width over tires (std. tires)	4.93 m	16'2"	4.93 m	16'2"
Tires used for measurements	50/65-51 (L-5)		50/65-51 (L-5)	

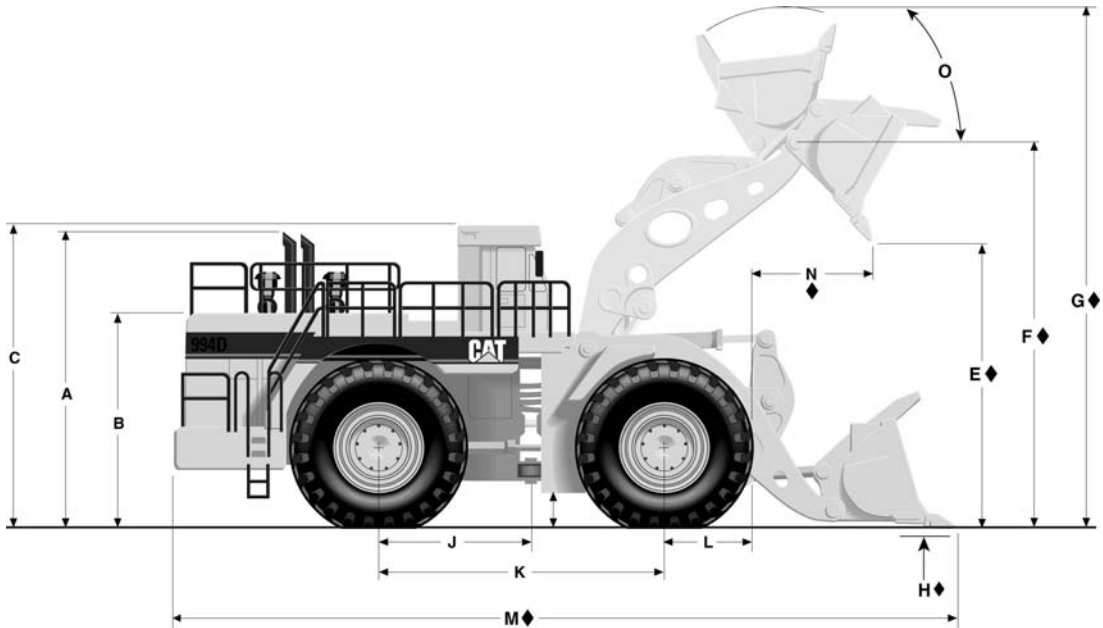

Dimensions shown represent standard machine with spade edge rock bucket and standard tires.

◆ Varies with Bucket Size and/or Bucket Configuration — Refer to Performance Data

MODEL	994F Standard Lift 5640 mm (18'6") Spade Edge Bucket with Teeth & Segments		994F Standard Lift 5640 mm (18'6") Spade Edge Bucket with Teeth & Segments		994F Standard Lift 5640 mm (18'6") Spade Edge Bucket with Teeth & Segments	
	15 m <sup>3</sup>	19.5 yd <sup>3</sup>	17 m <sup>3</sup>	22.5 yd <sup>3</sup>	19 m <sup>3</sup>	25 yd <sup>3</sup>
A Height to top of stack	7.0 m	23'0"	7.0 m	23'0"	7.0 m	23'0"
B Height to top of engine compartment	4.84 m	15.9'	4.84 m	15.9'	4.84 m	15.9'
C Height to top of ROPS	6.75 m	22.1'	6.75 m	22.1'	6.75 m	22.1'
D Hinge pin height at carry position	1030 mm	3.4'	1030 mm	3.4'	1030 mm	3.4'
◆ E Dump clearance at full lift and 45° discharge angle	5.77 m	18.9'	6 m	19.8'	5.6 m	18.3'
◆ F Hinge pin height at full lift	8.16 m	26.8'	8.16 m	26.8'	8.16 m	26.8'
◆ G Maximum overall height	10.7 m	35.2'	10.87 m	35.7'	10.9 m	35.9'
◆ H Maximum digging depth	108 mm	4"	108 mm	4"	68 mm	3"
J Machine center point to axle	3.2 m	10.5'	3.2 m	10.5'	3.2 m	10.5'
K Wheel base	6.4 m	21'0"	6.4 m	21'0"	6.4 m	21'0"
L Radius of tire	2.0 m	6.5'	2.0 m	6.5'	2.0 m	6.5'
◆ M Maximum overall length	16.6 m	54.5'	16.74 m	54.9'	16.86 m	55.3'
◆ N Reach at full lift	2.07 m	6.8'	2.2 m	7.2'	2.3 m	7.6'
O Maximum rollback at maximum lift		64°		64°		64°
P Maximum rollback at carry height		53°		53°		53°
Q Maximum rollback at ground		40°		40°		40°
Ground clearance (std. tires)	820 mm	33.5"	820 mm	33.5"	820 mm	33.5"
Tread width (std. tires)	4.1 m	13.6'	4.1 m	13.6'	4.1 m	13.6'
Width over tires (std. tires)	5.5 m	18.1'	5.5 m	18.1'	5.5 m	18.1'
Tires used for measurements	53.5/85-57		53.5/85-57		53.5/85-57	

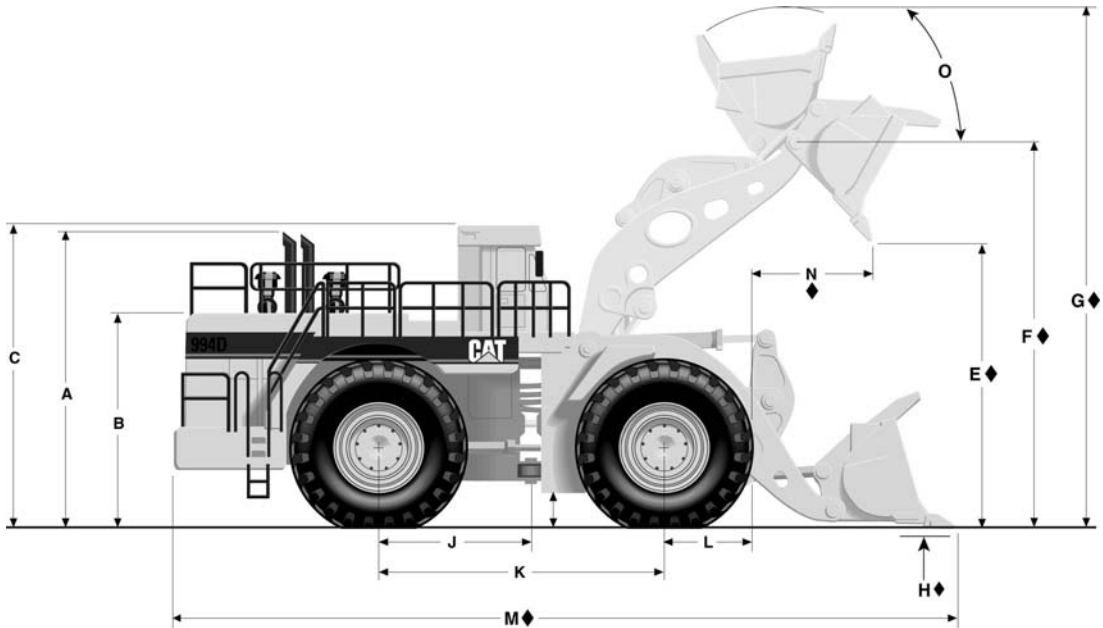

Dimensions shown represent standard machine with spade edge rock bucket and standard tires.

◆ Varies with Bucket Size and/or Bucket Configuration — Refer to Performance Data

MODEL	994F High Lift 5640 mm (18'6") Spade Edge Bucket with Teeth & Segments		994F High Lift 6200 mm (20'4") Spade Edge Bucket with Teeth & Segments		994F High Lift 6200 mm (20'4") Straight Edge Coal Bucket	
	17 m <sup>3</sup>	22.5 yd <sup>3</sup>	19 m <sup>3</sup>	25 yd <sup>3</sup>	31 m <sup>3</sup>	41 yd <sup>3</sup>
A Height to top of stack	6.99 m	23'0"	6.99 m	23'0"	6.99 m	23'0"
B Height to top of engine compartment	4.84 m	15.9'	4.84 m	15.9'	4.84 m	15.9'
C Height to top of ROPS	6.75 m	22.1'	6.75 m	22.1'	6.75 m	22.1'
D Hinge pin height at carry position	1258 mm	4.2'	1258 mm	4.2'	1258 mm	4.2'
◆ E Dump clearance at full lift and 45° discharge angle	6.0 m	19.8'	5.9 m	19.3'	5.97 m	19.6'
◆ F Hinge pin height at full lift	8.5 m	27.9'	8.5 m	27.9'	8.46 m	27.8'
◆ G Maximum overall height	11.2 m	36.7'	10.97 m	36.0'	12.2 m	40.0'
◆ H Maximum digging depth	123 mm	4.8"	82 mm	3"	78 mm	3"
J Machine center point to axle	3.2 m	10.5'	3.2 m	10.5'	3.2 m	10.5'
K Wheel base	6.4 m	21'0"	6.4 m	21'0"	6.4 m	21'0"
L Radius of tire	2.0 m	6.5'	2.0 m	6.5'	2.0 m	6.5'
◆ M Maximum overall length	17.53 m	57.5'	17.64 m	57.9'	17.6 m	57.7'
◆ N Reach at full lift	2.72 m	8.9'	2.76 m	9.1'	2.87 m	9.4'
O Maximum rollback at maximum lift	64°		64°		64°	
P Maximum rollback at carry height	58°		58°		58°	
Q Maximum rollback at ground	40°		40°		40°	
Ground clearance (std. tires)	820 mm	2.7'	820 mm	2.7'	820 mm	2.7'
Tread width (std. tires)	4.1 m	13.6'	4.1 m	13.6'	4.1 m	13.6'
Width over tires (std. tires)	5.46 m	17.8'	5.46 m	17.8'	5.46 m	17.8'
Tires used for measurements	53.5/85-57		53.5/85-57		53.5/85-57	

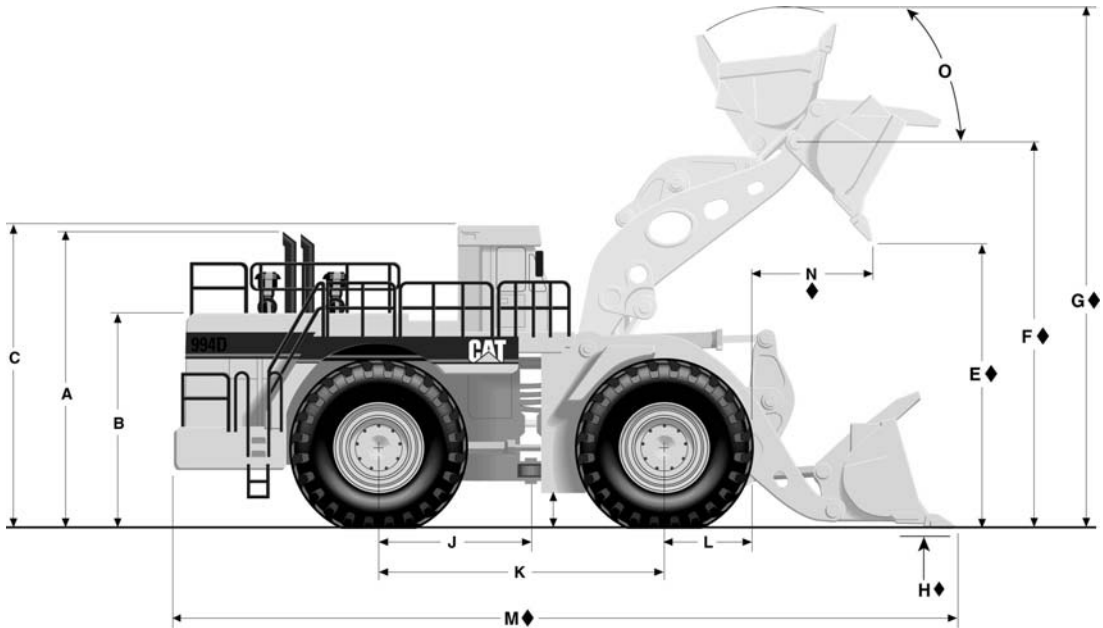

Dimensions shown represent standard machine with spade edge rock bucket and standard tires.

◆ Varies with Bucket Size and/or Bucket Configuration — Refer to Performance Data

MODEL	994F Extended High Lift 5640 mm (18'6") Spade Edge Bucket with Teeth & Segments		994F Extended High Lift 6200 mm (20'4") Spade Edge Bucket with Teeth & Segments	
	17 m <sup>3</sup>	22.5 yd <sup>3</sup>	19 m <sup>3</sup>	25 yd <sup>3</sup>
A Height to top of stack	7.01 m	23'0"	7.01 m	23'0"
B Height to top of engine compartment	4.85 m	15.9'	4.85 m	15.9'
C Height to top of ROPS	6.75 m	22.1'	6.75 m	22.1'
D Hinge pin height at carry position	1545 mm	5.1'	1545 mm	5.1'
◆E Dump clearance at full lift and 45° discharge angle	7.1 m	23.3'	7.0 m	23.0'
◆F Hinge pin height at full lift	9.6 m	31.3'	9.6 m	31.3'
◆G Maximum overall height	12.3 m	40.3'	12.3 m	40.5'
◆H Maximum digging depth	89 mm	4"	89 mm	4"
J Machine center point to axle	3.2 m	10.5'	3.2 m	10.5'
K Wheel base	6.4 m	21'0"	6.4 m	21'0"
L Radius of tire	2.0 m	6.5'	2.0 m	6.5'
◆M Maximum overall length	18.3 m	59.9'	18.5 m	60.9'
◆N Reach at full lift	2.7 m	8.9'	2.8 m	9.3'
O Maximum rollback at maximum lift		64°		64°
P Maximum rollback at carry height		58°		58°
Q Maximum rollback at ground		40°		40°
Ground clearance (std. tires)	830 mm	2.7'	830 mm	2.7'
Tread width (std. tires)	4.1 m	13.6'	4.1 m	13.6'
Width over tires (std. tires)	5.52 m	18.1'	5.52 m	18.1'
Tires used for measurements		58/85-57		58/85-57

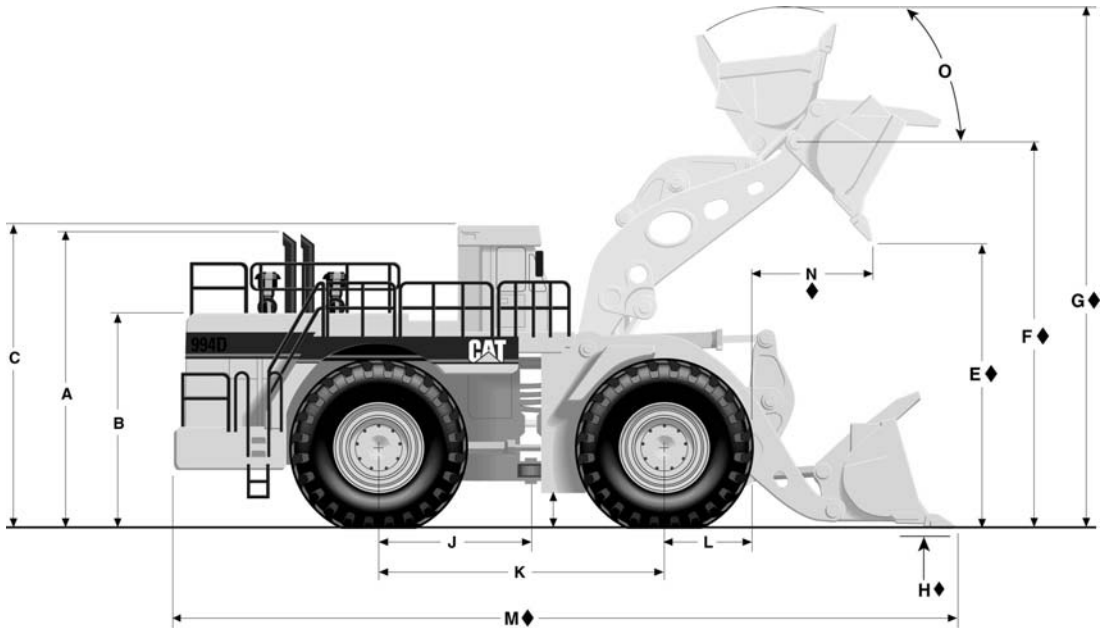

Dimensions shown represent standard machine with spade edge rock bucket and standard tires.

◆ Varies with Bucket Size and/or Bucket Configuration — Refer to Performance Data

MODEL	994F Extended High Lift 6200 mm (20'4") Straight Edge Coal Bucket		994F Super High Lift 6500 mm (21'4") Serrated Edge Coal Bucket	
	31 m <sup>3</sup>	41 yd <sup>3</sup>	36 m <sup>3</sup>	47 yd <sup>3</sup>
A Height to top of stack	7.01 m	23'0"	7.0 m	23'0"
B Height to top of engine compartment	4.85 m	15.9'	4.85 m	15.9'
C Height to top of ROPS	6.75 m	22.1'	6.75 m	22.1'
D Hinge pin height at carry position	1545 mm	5.1'	1649 mm	5.4'
◆E Dump clearance at full lift and 45° discharge angle	7.1 m	23.2'	7.34 m	24.1'
◆F Hinge pin height at full lift	9.6 m	31.3'	10.1 m	33.1'
◆G Maximum overall height	13.3 m	43.5'	14.4 m	47.2'
◆H Maximum digging depth	89 mm	4"	299 mm	11.8"
J Machine center point to axle	3.2 m	10.5'	3.2 m	10.5'
K Wheel base	6.4 m	21'0"	6.4 m	21'0"
L Radius of tire	2.0 m	6.5'	2.0 m	6.5'
◆M Maximum overall length	18.5 m	60.9'	19.5 m	64.0'
◆N Reach at full lift	2.9 m	9.5'	3.4 m	11.1'
O Maximum rollback at maximum lift		64°		64°
P Maximum rollback at carry height		58°		58°
Q Maximum rollback at ground		40°		40°
Ground clearance (std. tires)	830 mm	2.7'	830 mm	2.7'
Tread width (std. tires)	4.1 m	13.6'	4.1 m	13.6'
Width over tires (std. tires)	5.52 m	18.1'	5.52 m	18.1'
Tires used for measurements		58/85-57		58/85-57

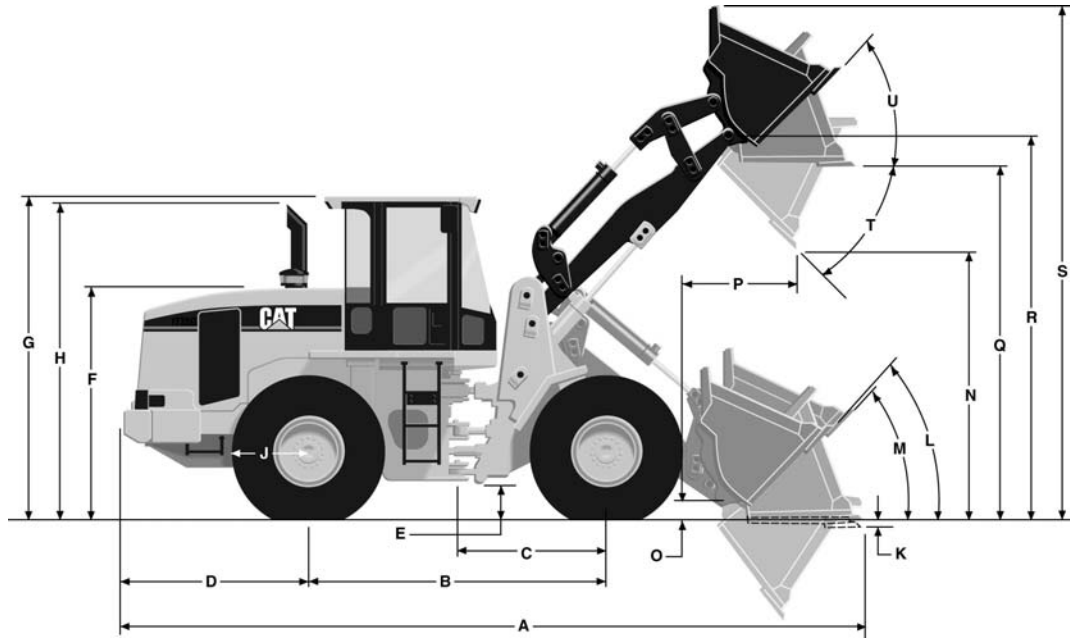

MODEL	IT14G		924H* Standard		924H* High Lift	
Bucket	1.3 m <sup>3</sup>	1.7 yd <sup>3</sup>	1.8 m <sup>3</sup>	2.3 yd <sup>3</sup>	1.8 m <sup>3</sup>	2.3 yd <sup>3</sup>
A Maximum overall length	6424 mm	21'1"	7147 mm	23'5"	7795 mm	25'7"
B Wheel base	2600 mm	8'6"	2800 mm	9'2"	2800 mm	9'3"
C Machine center point to front axle	1300 mm	4'3"	1400 mm	4'7"	1400 mm	4'8"
D Rear axle to counterweight	1658 mm	5'5"	1962 mm	6'5"	1962 mm	6'5"
E Ground clearance	456 mm	18"	436 mm	17"	436 mm	17"
F Height to top of engine compartment	2080 mm	6'10"	2219 mm	7'4"	2218 mm	7'4"
G Height to top of ROPS	3100 mm	10'2"	3227 mm	10'8"	3226 mm	10'8"
H Height to top of stack	2255 mm	7'5"	3211 mm	10'7"	3210 mm	10'7"
J Tire radius (empty machine)	620 mm	2'0"	—	—	—	—
K Maximum digging depth (bucket level)	175 mm	6.9"	64 mm	2.5"	75 mm	3"
L Maximum rollback at carry height		54°		51°		54°
M Maximum rollback at ground		49°		50°		50°
N Dump clearance at full lift and 45° discharge angle	2920 mm	9'7"	2828 mm	9'4"	3335 mm	10'11"
O Hinge pin height at carry position	374 mm	15"	435 mm	17"	592 mm	23"
P Reach at full lift and 45° dump	787 mm	2'7"	992 mm	3'3"	993 mm	3'4"
Q Clearance level bucket at full height	3565 mm	11'8"	3556 mm	11'8"	4063 mm	13'4"
R Maximum hinge pin height	3798 mm	12'6"	3881 mm	12'8"	4387 mm	14'5"
S Maximum overall height	4801 mm	15'9"	5178 mm	16'11"	5684 mm	18'8"
T Full dump at maximum lift		48°		45°		45°
U Maximum roll back at maximum lift		57°		58°		62°
Height to center of axle	—	—	692 mm	2'4"	692 mm	2'4"
Tires		17.5R25		20.5R25 (L-3)		20.5R25 (L-3)

\*VersaLink/Hook On.



# Wheel Loaders Integrated Toolcarriers

## Machine Dimensions

- with General Purpose Buckets and Bolt-on Cutting Edge

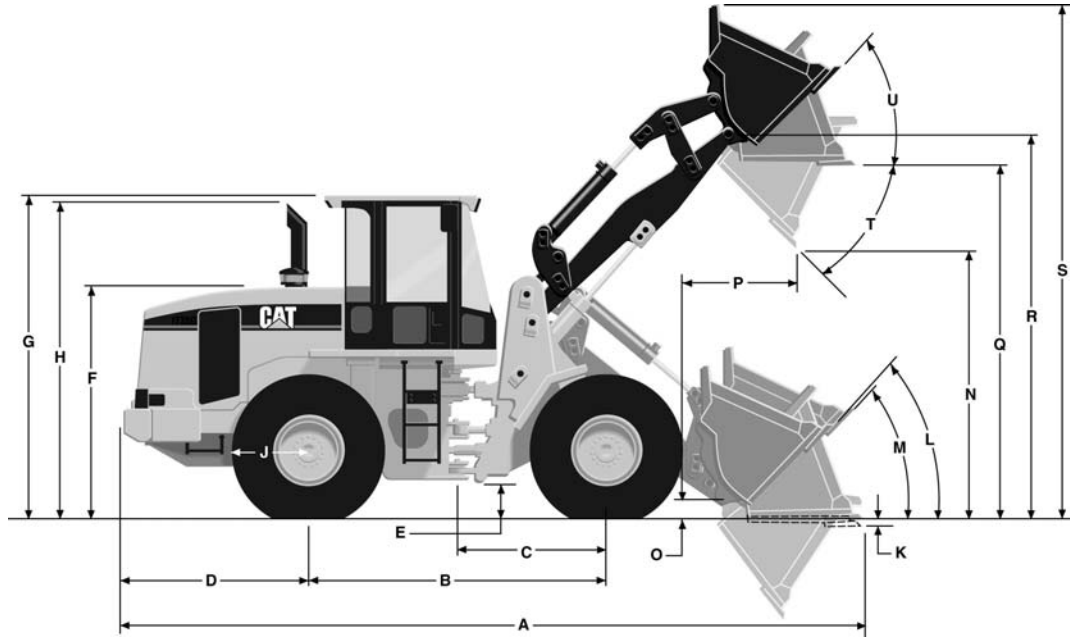

MODEL	930H* Standard		930H* High Lift		IT38H		IT62H	
Bucket	2.1 m <sup>3</sup>	2.7 yd <sup>3</sup>	2.1 m <sup>3</sup>	2.7 yd <sup>3</sup>	2.5 m <sup>3</sup>	3.3 yd <sup>3</sup>	3.5 m <sup>3</sup>	4.6 yd <sup>3</sup>
A Maximum overall length	7601 mm	24'11"	8080 mm	26'6"	7598 mm	24'11"	8422 mm	27'7"
B Wheel base	2900 mm	9'6"	2900 mm	9'6"	3020 mm	9'11"	3350 mm	11'0"
C Machine center point to front axle	1450 mm	4'9"	1450 mm	4'9"	1510 mm	4'11"	1675 mm	5'6"
D Rear axle to counterweight	1988 mm	6'6"	1988 mm	6'6"	1954 mm	6'4"	2000 mm	6'7"
E Ground clearance	411 mm	16"	411 mm	16"	397 mm	15"	412 mm	16"
F Height to top of engine compartment	2234 mm	7'4"	2234 mm	7'4"	2415 mm	7'11"	2462 mm	8'1"
G Height to top of ROPS	3278 mm	10'9"	3278 mm	10'9"	3356 mm	11'0"	3452 mm	11'4"
H Height to top of stack	3205 mm	10'6"	3205 mm	10'6"	3099 mm	10'2"	3369 mm	11'1"
J Tire radius (empty machine)	—	—	—	—	741 mm	2'5"	835 mm	2'9"
K Maximum digging depth (bucket level)	201 mm	8"	201 mm	8"	110 mm	4.3"	75 mm	2.97"
L Maximum rollback at carry height	53°	53°	57°	57°	46°	46°	53°	53°
M Maximum rollback at ground	51°	51°	52°	52°	48°	48°	46°	46°
N Dump clearance at full lift and 45° discharge angle	2833 mm	9'4"	3333 mm	10'11"	2761 mm	9'0"	2825 mm	9'3"
O Hinge pin height at carry position	428 mm	16"	577 mm	22"	235 mm	9.3"	315 mm	12"
P Reach at full lift and 45° dump	934 mm	3'1"	934 mm	3'1"	1135 mm	3'8"	1236 mm	4'0"
Q Clearance level bucket at full height	3667 mm	12'0"	4169 mm	13'8"	3585 mm	11'9"	3755 mm	12'3"
R Maximum hinge pin height	4049 mm	13'3"	4549 mm	14'11"	4061 mm	13'4"	4123 mm	13'6"
S Maximum overall height	5303 mm	17'5"	5803 mm	19'0"	5185 mm	17'0"	5628 mm	18'5"
T Full dump at maximum lift	45°	45°	45°	45°	45°	45°	49°	49°
U Maximum roll back at maximum lift	60°	60°	62°	62°	45°	45°	58°	58°
Height to center axle	685 mm	2'3"	685 mm	2'3"	688 mm	2'3"	744 mm	2'5"
Tires	20.5R25 (L3)		20.5R25 (L3)		20.5R25		23.5R25	

\*VersaLink/Hook On.

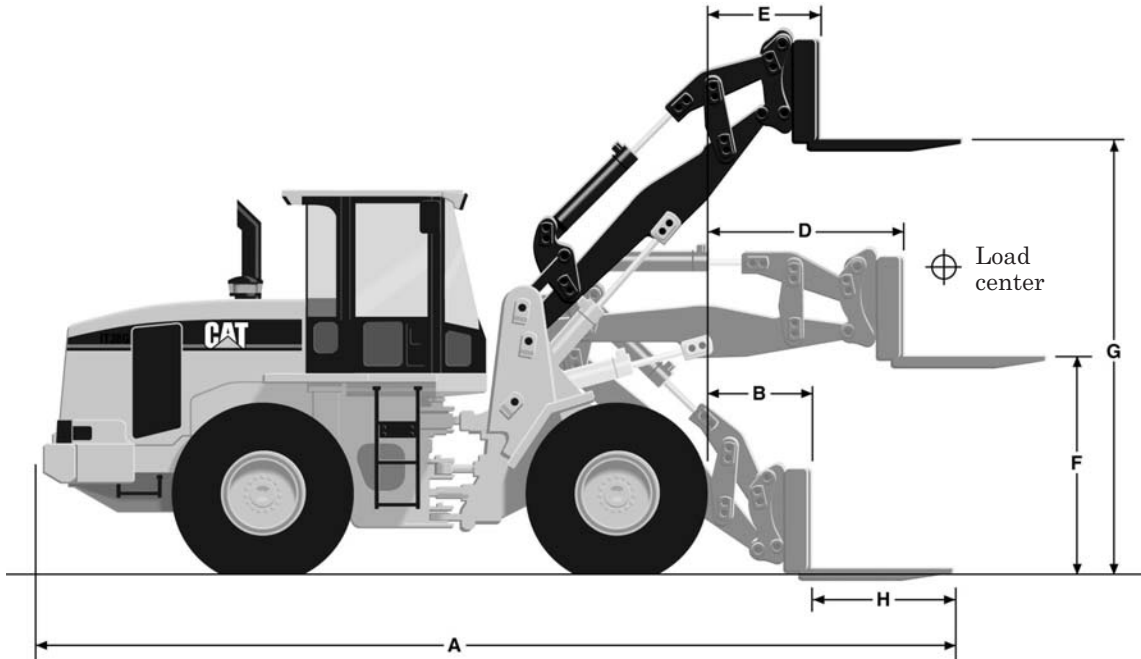

MODEL	IT14G		924H* Standard		924H* High Lift	
Rated operating load						
Per SAE J1197	1870 kg	<b>4123 lb</b>	2724 kg	<b>5993 lb</b>	2329 kg	<b>5124 lb</b>
Per CEN 474-3 rough terrain	2244 kg	<b>4948 lb</b>	3279 kg	<b>7214 lb</b>	2803 kg	<b>6167 lb</b>
Per CEN 474-3 firm level ground	2992 kg	<b>6597 lb</b>	4372 kg	<b>9618 lb</b>	3738 kg	<b>8224 lb</b>
A Maximum overall length	6873 mm	<b>22'7"</b>	7604 mm	<b>24'11"</b>	8113 mm	<b>26'7"</b>
B Reach with forks at ground level	745 mm	<b>2'5"</b>	871 mm	<b>2'10"</b>	1379 mm	<b>4'6"</b>
C Load center	600 mm	<b>24"</b>	600 mm	<b>24"</b>	600 mm	<b>24"</b>
D Reach with arms horizontal and forks level	1490 mm	<b>4'11"</b>	1562 mm	<b>5'1"</b>	1953 mm	<b>6'5"</b>
E Reach with fork at maximum height	586 mm	<b>1'11"</b>	762 mm	<b>2'6"</b>	762 mm	<b>2'6"</b>
F Arms horizontal and forks level	1808 mm	<b>5'11"</b>	1790 mm	<b>5'10"</b>	1790 mm	<b>5'10"</b>
G Ground to top of tine at maximum height	3708 mm	<b>12'2"</b>	3637 mm	<b>11'11"</b>	4145 mm	<b>13'7"</b>
H Fork tine length	1200 mm	<b>3'11"</b>	1220 mm	<b>4'0"</b>	1220 mm	<b>4'0"</b>
Tires	<b>17.5R25</b>		<b>20.5R25 (L-3)</b>		<b>20.5R25 (L-3)</b>	

\*VersaLink/Hook On.

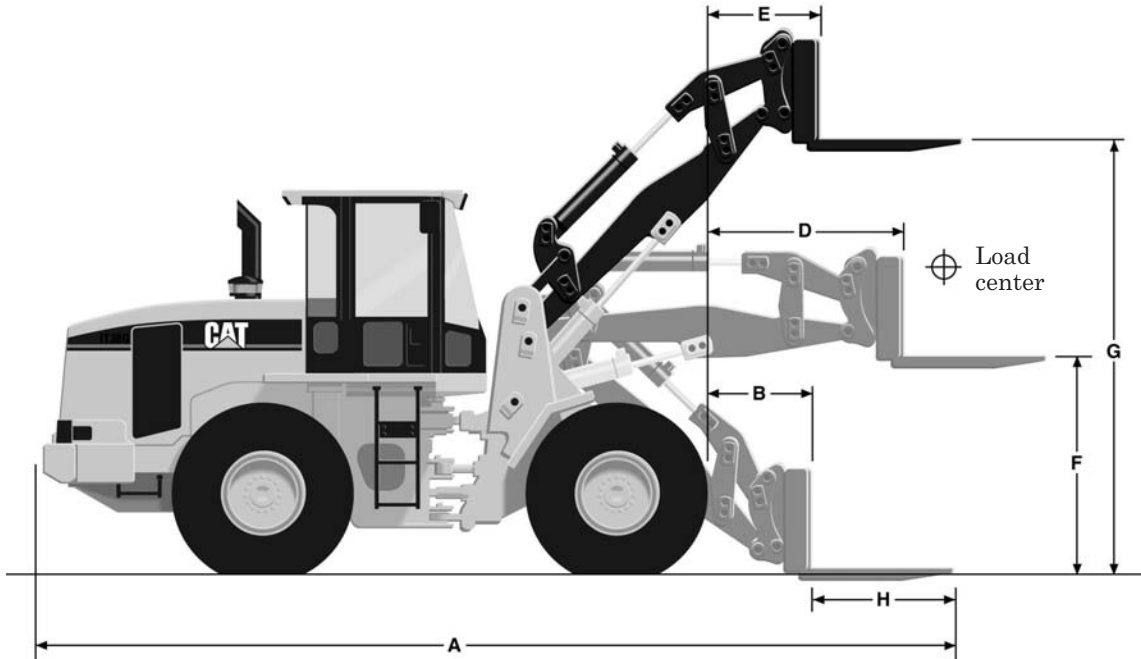

<b>MODEL</b>	<b>930H* Standard</b>		<b>930H* High Lift</b>	
Static tipping load with arms horizontal and forks level				
Straight	7247 kg	<b>15,943 lb</b>	6265 kg	<b>13,783 lb</b>
Articulated	6357 kg	<b>13,985 lb</b>	5477 kg	<b>12,049 lb</b>
Rated operating load				
Per SAE J1197	3179 kg	<b>6993 lb</b>	2739 kg	<b>6026 lb</b>
Per CEN 474-3 rough terrain	3827 kg	<b>8419 lb</b>	3296 kg	<b>7251 lb</b>
Per CEN 474-3 firm level ground	5102 kg	<b>11,225 lb</b>	4394 kg	<b>9668 lb</b>
<b>A</b> Maximum overall length	7854 mm	<b>25'9"</b>	8360 mm	<b>27'5"</b>
<b>B</b> Reach with forks at ground level	994 mm	<b>3'3"</b>	1500 mm	<b>4'11"</b>
<b>C</b> Load center	600 mm	<b>24"</b>	600 mm	<b>24"</b>
<b>D</b> Reach with arms horizontal and forks level	1693 mm	<b>5'7"</b>	2086 mm	<b>6'10"</b>
<b>E</b> Reach with fork at maximum height	772 mm	<b>2'6"</b>	772 mm	<b>2'6"</b>
<b>F</b> Reach at end of forks with arms horizontal and forks level	1861 mm	<b>6'1"</b>	1861 mm	<b>6'1"</b>
<b>G</b> Ground to top of tine at maximum height	3889 mm	<b>12'9"</b>	4389 mm	<b>14'5"</b>
<b>H</b> Fork tine length	1200 mm	<b>3'11"</b>	1200 mm	<b>3'11"</b>
Tires	<b>20.5R25 (L3)</b>		<b>20.5R25 (L3)</b>	

\*VersaLink/Hook On.

Machine Dimensions  
 ● with Fusion Pallet Forks

Wheel Loaders  
 Integrated Toolcarriers

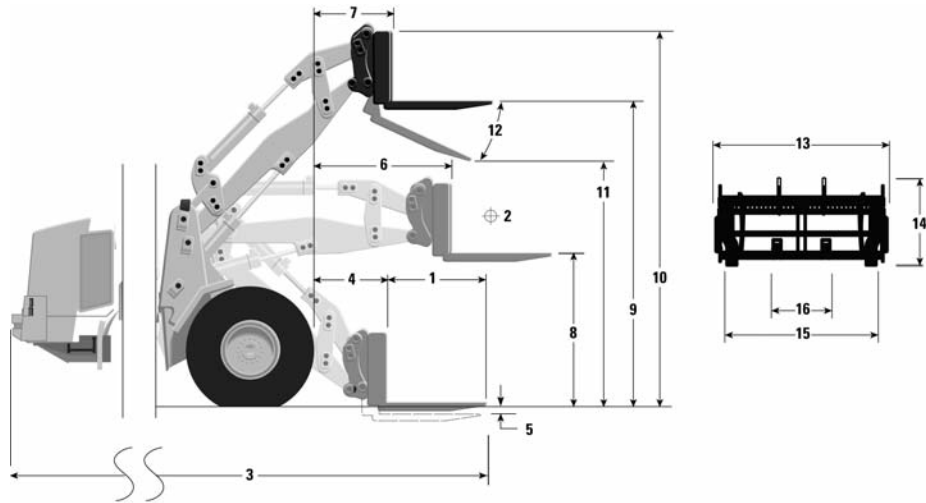

MODEL

IT38H

1 Fork tine length	1219 mm	48"	1524 mm	60"	1829 mm	72"
2 Load center	610 mm	24"	762 mm	30"	914 mm	36"
Tipping load — forks level straight	8857 kg	19,520 lb	8395 kg	18,502 lb	7972 kg	17,570 lb
Tipping load — forks level articulated	7664 kg	16,891 lb	7259 kg	15,999 lb	6889 kg	15,183 lb
Rated load (SAE J1197)	3832 kg	8445 lb	3630 kg	8000 lb	3444 kg	7591 lb
Rated load (CEN EN 474-3 rough terrain)	4598 kg	10,134 lb	4356 kg	9600 lb	4133 kg	9110 lb
Rated load (CEN EN 474-3 firm and level ground)	6131 kg	13,513 lb	5807 kg	12,799 lb	5511 kg	12,146 lb
3 Maximum overall length	7924 mm	312.0"	8228 mm	324.0"	8533 mm	336.0"
4 Reach with forks at ground level	980 mm	38.6"	980 mm	38.6"	980 mm	38.6"
5 Ground to top of tine at minimum height and fork level	66 mm	2.6"	66 mm	2.6"	66 mm	2.6"
6 Reach with arms horizontal and forks level	1584 mm	62.4"	1584 mm	62.4"	1584 mm	62.4"
7 Reach with fork at maximum height	855 mm	33.6"	855 mm	33.6"	855 mm	33.6"
8 Ground to top of tine with arms horizontal and fork level	1774 mm	69.8"	1774 mm	69.8"	1774 mm	69.8"
9 Ground to top of tine at maximum height and fork level	3629 mm	142.9"	3629 mm	142.9"	3629 mm	142.9"
10 Overall height of fork at full lift (top of carriage to ground)	4699 mm	185.0"	4699 mm	185.0"	4699 mm	185.0"
11 Clearance at full lift and maximum dump	2408 mm	94.8"	2152 mm	84.7"	1896 mm	74.6"
12 Maximum discharge angle from horizontal		57°		57°		57°
13 Carriage width	2235 mm	88.0"	2235 mm	88.0"	2235 mm	88.0"
14 Carriage height	1133 mm	44.6"	1133 mm	44.6"	1133 mm	44.6"
15 Outside tine width (maximum spread)	1969 mm	77.5"	1969 mm	77.5"	1969 mm	77.5"
16 Outside tine width (minimum spread)	425 mm	16.7"	425 mm	16.7"	425 mm	16.7"
Tine width (single tine)	152 mm	6.0"	152 mm	6.0"	152 mm	6.0"
Tine thickness	64 mm	2.5"	64 mm	2.5"	64 mm	2.5"
Operating weight	15 906 kg	35,056 lb	15 943 kg	35,139 lb	15 981 kg	35,221 lb

Based on 2134 mm (84") carriage, Fusion coupler and Fusion pallet fork.

Static tipping loads and operating weight are based on the following loader configuration: L3 Michelin XHA tires, air conditioning, ride control, power train guard, full fluids, fuel tank, coolant, lubricants, and operator. Static tipping loads conform to the international standard as defined in ISO\* 14397-1 (Sept2007).

Specifications and ratings conform to the following standards: ISO 14397-1, SAE\*\* J1197, SAE J732, CEN\*\*\* EN 474-3.

The rated operating load for a loader equipped with a pallet fork is determined by:

- SAE J1197: 50% of full turn static tipping load or hydraulic limit.
- CEN EN 474-3: 60% of full turn static tipping load on rough terrain or hydraulic limit.
- CEN EN 474-3: 80% of full turn static tipping load on firm and level ground or hydraulic limit.

\*ISO — International Organization for Standardization

\*\*SAE — Society of Automotive Engineers

\*\*\*CEN — European Committee for Standardization

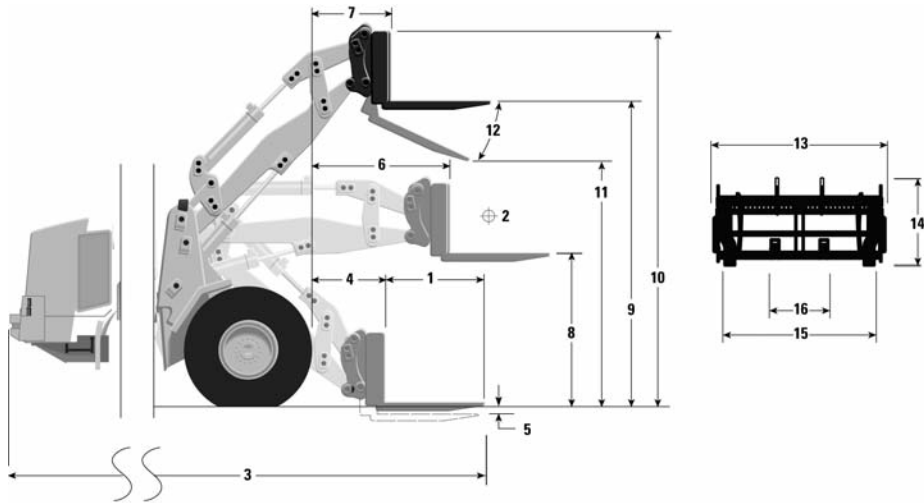

### MODEL

### IT62H

	1524 mm	60"	1829 mm	72"	2134 mm	84"	2438 mm	96"
1 Fork tine length	1524 mm	60"	1829 mm	72"	2134 mm	84"	2438 mm	96"
2 Load center	762 mm	30"	914 mm	36"	1067 mm	42"	1219 mm	48"
Tipping load — forks level straight	9760 kg	<b>21,512 lb</b>	9284 kg	<b>20,462 lb</b>	8841 kg	<b>19,485 lb</b>	8428 kg	<b>18,576 lb</b>
Tipping load — forks level articulated	8321 kg	<b>18,340 lb</b>	7906 kg	<b>17,424 lb</b>	7519 kg	<b>16,571 lb</b>	7158 kg	<b>15,776 lb</b>
Rated load (SAE J1197)	4161 kg	<b>9170 lb</b>	3953 kg	<b>8712 lb</b>	3759 kg	<b>8286 lb</b>	3579 kg	<b>7888 lb</b>
Rated load (CEN EN 474-3 rough terrain)	4993 kg	<b>11,004 lb</b>	4743 kg	<b>10,455 lb</b>	4511 kg	<b>9943 lb</b>	4295 kg	<b>9466 lb</b>
Rated load (CEN EN 474-3 firm and level ground)	6657 kg	<b>14,672 lb</b>	6325 kg	<b>13,939 lb</b>	6015 kg	<b>13,257 lb</b>	5726 kg	<b>12,621 lb</b>
3 Maximum overall length	8972 mm	<b>353.2"</b>	9277 mm	<b>365.3"</b>	9582 mm	<b>377.3"</b>	9887 mm	<b>389.3"</b>
4 Reach with forks at ground level	1263 mm	<b>49.7"</b>	1264 mm	<b>49.8"</b>	1264 mm	<b>49.8"</b>	1264 mm	<b>49.8"</b>
5 Ground to top of tine at minimum height and fork level	27 mm	<b>1.1"</b>	27 mm	<b>1.1"</b>	27 mm	<b>1.1"</b>	27 mm	<b>1.1"</b>
6 Reach with arms horizontal and forks level	1782 mm	<b>70.2"</b>	1782 mm	<b>70.2"</b>	1782 mm	<b>70.2"</b>	1783 mm	<b>70.2"</b>
7 Reach with fork at maximum height	923 mm	<b>36.4"</b>	924 mm	<b>36.4"</b>	924 mm	<b>36.4"</b>	924 mm	<b>36.4"</b>
8 Ground to top of tine with arms horizontal and fork level	1744 mm	<b>68.6"</b>	1744 mm	<b>68.6"</b>	1744 mm	<b>68.6"</b>	1744 mm	<b>68.6"</b>
9 Ground to top of tine at maximum height and fork level	3803 mm	<b>149.7"</b>	3803 mm	<b>149.7"</b>	3803 mm	<b>149.7"</b>	3803 mm	<b>149.7"</b>
10 Overall height of fork at full lift (top of carriage to ground)	5049 mm	<b>198.8"</b>	5049 mm	<b>198.8"</b>	5049 mm	<b>198.8"</b>	5049 mm	<b>198.8"</b>
11 Clearance at full lift and maximum dump	2214 mm	<b>87.2"</b>	1944 mm	<b>76.5"</b>	1674 mm	<b>65.9"</b>	1404 mm	<b>55.3"</b>
12 Maximum discharge angle from horizontal		<b>62°</b>		<b>62°</b>		<b>62°</b>		<b>62°</b>
13 Carriage width	2540 mm	<b>100.0"</b>	2540 mm	<b>100.0"</b>	2540 mm	<b>100.0"</b>	2540 mm	<b>100.0"</b>
14 Carriage height	1335 mm	<b>52.5"</b>	1335 mm	<b>52.5"</b>	1335 mm	<b>52.5"</b>	1335 mm	<b>52.5"</b>
15 Outside tine width (maximum spread)	2176 mm	<b>85.7"</b>	2176 mm	<b>85.7"</b>	2176 mm	<b>85.7"</b>	2176 mm	<b>85.7"</b>
16 Outside tine width (minimum spread)	620 mm	<b>24.4"</b>	620 mm	<b>24.4"</b>	620 mm	<b>24.4"</b>	620 mm	<b>24.4"</b>
Tine width (single tine)	178 mm	<b>7.0"</b>	178 mm	<b>7.0"</b>	178 mm	<b>7.0"</b>	178 mm	<b>7.0"</b>
Tine thickness	89 mm	<b>3.5"</b>	89 mm	<b>3.5"</b>	89 mm	<b>3.5"</b>	89 mm	<b>3.5"</b>
Operating weight	19 446 kg	<b>42,858 lb</b>	19 508 kg	<b>42,995 lb</b>	19 571 kg	<b>43,134 lb</b>	19 633 kg	<b>43,270 lb</b>

Based on 2438 mm (96") carriage, Fusion coupler and Fusion pallet fork.

Static tipping loads and operating weight are based on the following loader configuration: L3 Michelin XHA tires, air conditioning, ride control, power train guard, full fluids, fuel tank, coolant, lubricants, and operator. Static tipping loads conform to the international standard as defined in ISO\* 14397-1 (Sept2007).

Specifications and ratings conform to the following standards: ISO 14397-1, SAE\*\* J1197, SAE J732, CEN\*\*\* EN 474-3.

The rated operating load for a loader equipped with a pallet fork is determined by:

- SAE J1197: 50% of full turn static tipping load or hydraulic limit.
- CEN EN 474-3: 60% of full turn static tipping load on rough terrain or hydraulic limit.
- CEN EN 474-3: 80% of full turn static tipping load on firm and level ground or hydraulic limit.

\*ISO — International Organization for Standardization

\*\*SAE — Society of Automotive Engineers

\*\*\*CEN — European Committee for Standardization

Machine Dimensions  
 ● with Fusion Pallet Forks

Wheel Loaders  
 Integrated Toolcarriers

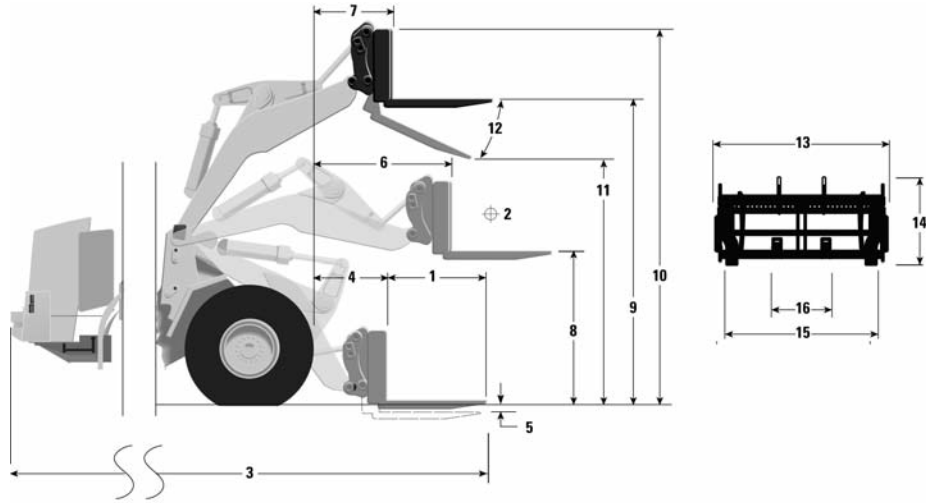

MODEL

938H

1 Fork tine length	1219 mm	48"	1524 mm	60"	1829 mm	72"
2 Load center	610 mm	24"	762 mm	30"	914 mm	36"
Tipping load — forks level straight	8677 kg	19,123 lb	8191 kg	18,053 lb	7749 kg	17,080 lb
Tipping load — forks level articulated	7547 kg	16,635 lb	7120 kg	15,692 lb	6731 kg	14,836 lb
Rated load (SAE J1197)	3774 kg	8317 lb	3560 kg	7846 lb	3366 kg	7418 lb
Rated load (CEN EN 474-3 rough terrain)	4528 kg	9981 lb	4272 kg	9415 lb	4039 kg	8901 lb
Rated load (CEN EN 474-3 firm and level ground)	6038 kg	13,308 lb	5312 kg	11,708 lb	4613 kg	10,167 lb
3 Maximum overall length	7659 mm	301.5"	7964 mm	313.5"	8269 mm	325.5"
4 Reach with forks at ground level	830 mm	32.7"	830 mm	32.7"	830 mm	32.7"
5 Ground to top of tine at minimum height and fork level	77 mm	3.0"	77 mm	3.0"	77 mm	3.0"
6 Reach with arms horizontal and forks level	1383 mm	54.4"	1383 mm	54.4"	1383 mm	54.4"
7 Reach with fork at maximum height	636 mm	25.0"	636 mm	25.0"	636 mm	25.0"
8 Ground to top of tine with arms horizontal and fork level	1676 mm	66.0"	1676 mm	66.0"	1676 mm	66.0"
9 Ground to top of tine at maximum height and fork level	3511 mm	138.2"	3511 mm	138.2"	3511 mm	138.2"
10 Overall height of fork at full lift (top of carriage to ground)	4581 mm	180.3"	4581 mm	180.3"	4581 mm	180.3"
11 Clearance at full lift and maximum dump	2511 mm	98.8"	2294 mm	90.3"	2077 mm	81.8"
12 Maximum discharge angle from horizontal		45°		45°		45°
13 Carriage width	2235 mm	88.0"	2235 mm	88.0"	2235 mm	88.0"
14 Carriage height	1133 mm	44.6"	1133 mm	44.6"	1133 mm	44.6"
15 Outside tine width (maximum spread)	1969 mm	77.5"	1969 mm	77.5"	1969 mm	77.5"
16 Outside tine width (minimum spread)	425 mm	16.7"	425 mm	16.7"	425 mm	16.7"
Tine width (single tine)	152 mm	6.0"	152 mm	6.0"	152 mm	6.0"
Tine thickness	64 mm	2.5"	64 mm	2.5"	64 mm	2.5"
Operating weight	15 017 kg	33,098 lb	15 055 kg	33,181 lb	15 092 kg	33,264 lb

Based on 2134 mm (84") carriage, Fusion coupler and Fusion pallet fork.

Static tipping loads and operating weight are based on the following loader configuration: L3 Michelin XHA tires, air conditioning, ride control, power train guard, full fluids, fuel tank, coolant, lubricants, and operator. Static tipping loads conform to the international standard as defined in ISO\* 14397-1 (Sept2007).

Specifications and ratings conform to the following standards: ISO 14397-1, SAE\*\* J1197, SAE J732, CEN\*\*\* EN 474-3.

The rated operating load for a loader equipped with a pallet fork is determined by:

- SAE J1197: 50% of full turn static tipping load or hydraulic limit.
- CEN EN 474-3: 60% of full turn static tipping load on rough terrain or hydraulic limit.
- CEN EN 474-3: 80% of full turn static tipping load on firm and level ground or hydraulic limit.

\*ISO — International Organization for Standardization

\*\*SAE — Society of Automotive Engineers

\*\*\*CEN — European Committee for Standardization

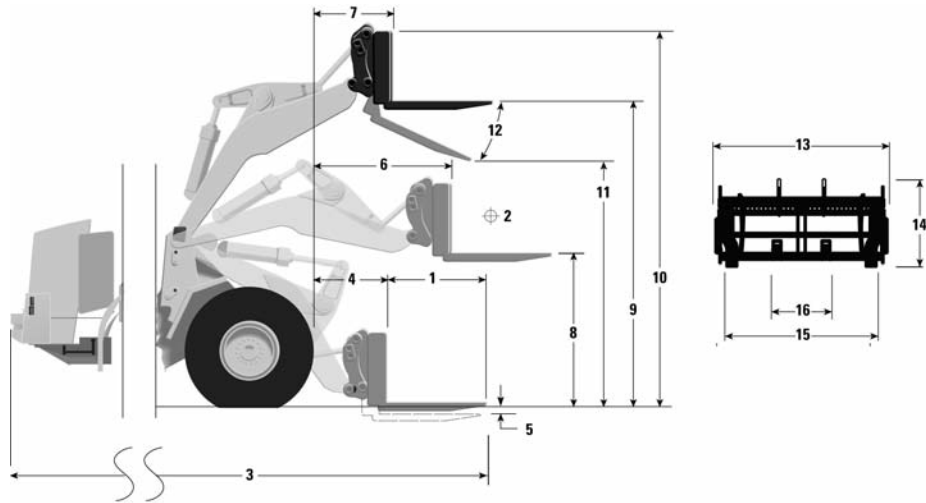

## MODEL

## 950H

1 Fork tine length	1524 mm	60"	1829 mm	72"	2134 mm	84"	2438 mm	96"
2 Load center	762 mm	30"	914 mm	36"	1067 mm	42"	1219 mm	48"
Tipping load — forks level straight	8687 kg	<b>19,146 lb</b>	8232 kg	<b>18,144 lb</b>	7811 kg	<b>17,215 lb</b>	7420 kg	<b>16,353 lb</b>
Tipping load — forks level articulated	7469 kg	<b>16,461 lb</b>	7068 kg	<b>15,578 lb</b>	6696 kg	<b>14,758 lb</b>	6351 kg	<b>13,998 lb</b>
Rated load (SAE J1197)	3734 kg	<b>8230 lb</b>	3534 kg	<b>7789 lb</b>	3348 kg	<b>7379 lb</b>	3176 kg	<b>6999 lb</b>
Rated load (CEN EN 474-3 rough terrain)	4481 kg	<b>9876 lb</b>	4241 kg	<b>9347 lb</b>	4018 kg	<b>8855 lb</b>	3811 kg	<b>8399 lb</b>
Rated load (CEN EN 474-3 firm and level ground)	5975 kg	<b>13,169 lb</b>	5539 kg	<b>12,208 lb</b>	4876 kg	<b>10,746 lb</b>	4331 kg	<b>9545 lb</b>
3 Maximum overall length	8642 mm	<b>340.3"</b>	8947 mm	<b>352.3"</b>	9252 mm	<b>364.3"</b>	9557 mm	<b>376.3"</b>
4 Reach with forks at ground level	1068 mm	<b>42.1"</b>	1069 mm	<b>42.1"</b>	1069 mm	<b>42.1"</b>	1069 mm	<b>42.1"</b>
5 Ground to top of tine at minimum height and fork level	83 mm	<b>3.3"</b>	83 mm	<b>3.3"</b>	83 mm	<b>3.3"</b>	83 mm	<b>3.3"</b>
6 Reach with arms horizontal and forks level	1625 mm	<b>64.0"</b>	1625 mm	<b>64.0"</b>	1625 mm	<b>64.0"</b>	1625 mm	<b>64.0"</b>
7 Reach with forks at maximum height	853 mm	<b>33.6"</b>	853 mm	<b>33.6"</b>	853 mm	<b>33.6"</b>	853 mm	<b>33.6"</b>
8 Ground to top of tine with arms horizontal and fork level	1762 mm	<b>69.4"</b>	1762 mm	<b>69.4"</b>	1762 mm	<b>69.4"</b>	1762 mm	<b>69.4"</b>
9 Ground to top of tine at maximum height and fork level	3691 mm	<b>145.3"</b>	3691 mm	<b>145.3"</b>	3691 mm	<b>145.3"</b>	3691 mm	<b>145.3"</b>
10 Overall height of fork at full lift (top of carriage to ground)	4937 mm	<b>194.4"</b>	4937 mm	<b>194.4"</b>	4937 mm	<b>194.4"</b>	4937 mm	<b>194.4"</b>
11 Clearance at full lift and maximum dump	2410 mm	<b>94.9"</b>	2190 mm	<b>86.2"</b>	1970 mm	<b>77.6"</b>	1750 mm	<b>68.9"</b>
12 Maximum discharge angle from horizontal		<b>46°</b>		<b>46°</b>		<b>46°</b>		<b>46°</b>
13 Carriage width	2540 mm	<b>100.0"</b>	2540 mm	<b>100.0"</b>	2540 mm	<b>100.0"</b>	2540 mm	<b>100.0"</b>
14 Carriage height	1335 mm	<b>52.5"</b>	1335 mm	<b>52.5"</b>	1335 mm	<b>52.5"</b>	1335 mm	<b>52.5"</b>
15 Outside tine width (maximum spread)	2176 mm	<b>85.7"</b>	2176 mm	<b>85.7"</b>	2176 mm	<b>85.7"</b>	2176 mm	<b>85.7"</b>
16 Outside tine width (minimum spread)	620 mm	<b>24.4"</b>	620 mm	<b>24.4"</b>	620 mm	<b>24.4"</b>	620 mm	<b>24.4"</b>
Tine width (single tine)	178 mm	<b>7.0"</b>	178 mm	<b>7.0"</b>	178 mm	<b>7.0"</b>	178 mm	<b>7.0"</b>
Tine thickness	89 mm	<b>3.5"</b>	89 mm	<b>3.5"</b>	89 mm	<b>3.5"</b>	89 mm	<b>3.5"</b>
Operating weight	18 369 kg	<b>40,485 lb</b>	18 431 kg	<b>40,622 lb</b>	18 494 kg	<b>40,761 lb</b>	18 556 kg	<b>40,898 lb</b>

Based on 2438 mm (96") carriage, Fusion coupler and Fusion pallet fork.

Static tipping loads and operating weight are based on the following loader configuration: L3 Michelin XHA tires, air conditioning, ride control, power train guard, full fluids, fuel tank, coolant, lubricants, and operator. Static tipping loads conform to the international standard as defined in ISO\* 14397-1 (Sept2007).

Specifications and ratings conform to the following standards: ISO 14397-1, SAE\*\* J1197, SAE J732, CEN\*\*\* EN 474-3.

The rated operating load for a loader equipped with a pallet fork is determined by:

- SAE J1197: 50% of full turn static tipping load or hydraulic limit.
- CEN EN 474-3: 60% of full turn static tipping load on rough terrain or hydraulic limit.
- CEN EN 474-3: 80% of full turn static tipping load on firm and level ground or hydraulic limit.

\*ISO — International Organization for Standardization

\*\*SAE — Society of Automotive Engineers

\*\*\*CEN — European Committee for Standardization

## Machine Dimensions ● with Fusion Pallet Forks

## Wheel Loaders Integrated Toolcarriers

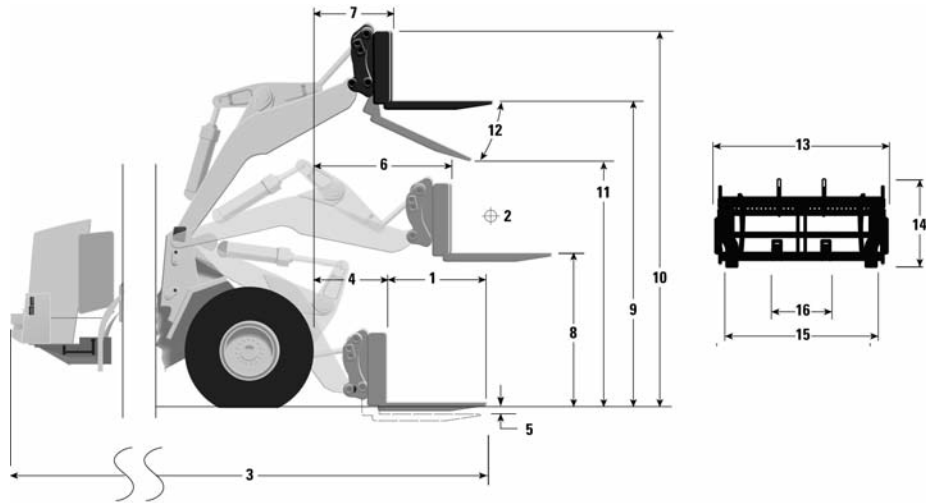

### MODEL

### 962H

	1524 mm	60"	1829 mm	72"	2134 mm	84"	2438 mm	96"
1 Fork tine length	1524 mm	60"	1829 mm	72"	2134 mm	84"	2438 mm	96"
2 Load center	762 mm	30"	914 mm	36"	1067 mm	42"	1219 mm	48"
Tipping load — forks level straight	9464 kg	<b>20,860 lb</b>	8987 kg	<b>19,808 lb</b>	8544 kg	<b>18,831 lb</b>	8133 kg	<b>17,926 lb</b>
Tipping load — forks level articulated	8070 kg	<b>17,786 lb</b>	7654 kg	<b>16,869 lb</b>	7267 kg	<b>16,016 lb</b>	6908 kg	<b>15,225 lb</b>
Rated load (SAE J1197)	4035 kg	<b>8893 lb</b>	3827 kg	<b>8434 lb</b>	3633 kg	<b>8008 lb</b>	3454 kg	<b>7613 lb</b>
Rated load (CEN EN 474-3 rough terrain)	4842 kg	<b>10,671 lb</b>	4592 kg	<b>10,121 lb</b>	4360 kg	<b>9610 lb</b>	4145 kg	<b>9135 lb</b>
Rated load (CEN EN 474-3 firm and level ground)	6127 kg	<b>13,505 lb</b>	5329 kg	<b>11,745 lb</b>	4688 kg	<b>10,333 lb</b>	4162 kg	<b>9174 lb</b>
3 Maximum overall length	8869 mm	<b>349.2"</b>	9174 mm	<b>361.2"</b>	9479 mm	<b>373.2"</b>	9784 mm	<b>385.2"</b>
4 Reach with forks at ground level	1160 mm	<b>45.7"</b>	1160 mm	<b>45.7"</b>	1161 mm	<b>45.7"</b>	1161 mm	<b>45.7"</b>
5 Ground to top of tine at minimum height and fork level	83 mm	<b>3.3"</b>	83 mm	<b>3.3"</b>	83 mm	<b>3.3"</b>	83 mm	<b>3.3"</b>
6 Reach with arms horizontal and forks level	1693 mm	<b>66.6"</b>	1693 mm	<b>66.7"</b>	1693 mm	<b>66.7"</b>	1693 mm	<b>66.7"</b>
7 Reach with forks at maximum height	771 mm	<b>30.3"</b>	771 mm	<b>30.3"</b>	771 mm	<b>30.4"</b>	771 mm	<b>30.4"</b>
8 Ground to top of tine with arms horizontal and fork level	1762 mm	<b>69.4"</b>	1762 mm	<b>69.4"</b>	1762 mm	<b>69.4"</b>	1762 mm	<b>69.4"</b>
9 Ground to top of tine at maximum height and fork level	3881 mm	<b>152.8"</b>	3881 mm	<b>152.8"</b>	3881 mm	<b>152.8"</b>	3881 mm	<b>152.8"</b>
10 Overall height of fork at full lift (top of carriage to ground)	5127 mm	<b>201.8"</b>	5127 mm	<b>201.8"</b>	5127 mm	<b>201.8"</b>	5127 mm	<b>201.8"</b>
11 Clearance at full lift and maximum dump	2610 mm	<b>102.7"</b>	2392 mm	<b>94.2"</b>	2174 mm	<b>85.6"</b>	1956 mm	<b>77.0"</b>
12 Maximum discharge angle from horizontal		<b>46°</b>		<b>46°</b>		<b>46°</b>		<b>46°</b>
13 Carriage width	2540 mm	<b>100.0"</b>	2540 mm	<b>100.0"</b>	2540 mm	<b>100.0"</b>	2540 mm	<b>100.0"</b>
14 Carriage height	1335 mm	<b>52.5"</b>	1335 mm	<b>52.5"</b>	1335 mm	<b>52.5"</b>	1335 mm	<b>52.5"</b>
15 Outside tine width (maximum spread)	2176 mm	<b>85.7"</b>	2176 mm	<b>85.7"</b>	2176 mm	<b>85.7"</b>	2176 mm	<b>85.7"</b>
16 Outside tine width (minimum spread)	620 mm	<b>24.4"</b>	620 mm	<b>24.4"</b>	620 mm	<b>24.4"</b>	620 mm	<b>24.4"</b>
Tine width (single tine)	177.8 mm	<b>7.0"</b>	177.8 mm	<b>7.0"</b>	177.8 mm	<b>7.0"</b>	177.8 mm	<b>7.0"</b>
Tine thickness	88.9 mm	<b>3.5"</b>	88.9 mm	<b>3.5"</b>	88.9 mm	<b>3.5"</b>	88.9 mm	<b>3.5"</b>
Operating weight	19 114 kg	<b>42,127 lb</b>	19 176 kg	<b>42,264 lb</b>	19 239 kg	<b>42,402 lb</b>	19 301 kg	<b>42,539 lb</b>

Based on 2438 mm (96") carriage, Fusion coupler and Fusion pallet fork.

Static tipping loads and operating weight are based on the following loader configuration: L3 Michelin XHA tires, air conditioning, ride control, power train guard, full fluids, fuel tank, coolant, lubricants, and operator. Static tipping loads conform to the international standard as defined in ISO\* 14397-1 (Sept2007).

Specifications and ratings conform to the following standards: ISO 14397-1, SAE\*\* J1197, SAE J732, CEN\*\*\* EN 474-3.

The rated operating load for a loader equipped with a pallet fork is determined by:

- SAE J1197: 50% of full turn static tipping load or hydraulic limit.
- CEN EN 474-3: 60% of full turn static tipping load on rough terrain or hydraulic limit.
- CEN EN 474-3: 80% of full turn static tipping load on firm and level ground or hydraulic limit.

\*ISO — International Organization for Standardization

\*\*SAE — Society of Automotive Engineers

\*\*\*CEN — European Committee for Standardization



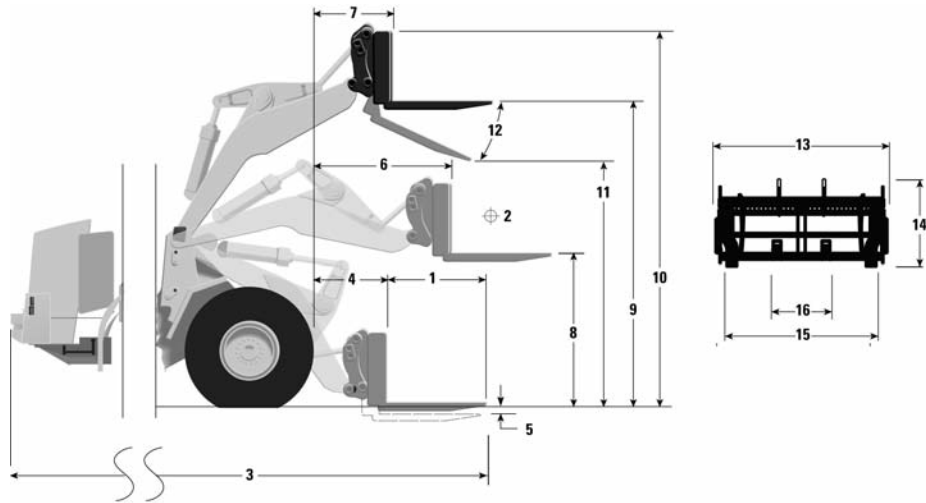

## MODEL

## 966H

1 Fork tine length	1524 mm	60"	1829 mm	72"	2134 mm	84"	2438 mm	96"
2 Load center	762 mm	30"	914 mm	36"	1067 mm	42"	1219 mm	48"
Tipping load — forks level straight	11 789 kg	<b>25,983 lb</b>	11 214 kg	<b>24,715 lb</b>	10 680 kg	<b>23,540 lb</b>	10 186 kg	<b>22,449 lb</b>
Tipping load — forks level articulated	10 387 kg	<b>22,892 lb</b>	9872 kg	<b>21,757 lb</b>	9394 kg	<b>20,705 lb</b>	8951 kg	<b>19,728 lb</b>
Rated load (SAE J1197)	5193 kg	<b>11,446 lb</b>	4936 kg	<b>10,879 lb</b>	4697 kg	<b>10,353 lb</b>	4476 kg	<b>9864 lb</b>
Rated load (CEN EN 474-3 rough terrain)	6232 kg	<b>13,735 lb</b>	5923 kg	<b>13,054 lb</b>	5637 kg	<b>12,423 lb</b>	5371 kg	<b>11,837 lb</b>
Rated load (CEN EN 474-3 firm and level ground)	8309 kg	<b>18,313 lb</b>	7739 kg	<b>17,056 lb</b>	6841 kg	<b>15,079 lb</b>	6107 kg	<b>13,461 lb</b>
3 Maximum overall length	9194 mm	<b>362.0"</b>	9499 mm	<b>374.0"</b>	9804 mm	<b>386.0"</b>	10 109 mm	<b>398.0"</b>
4 Reach with forks at ground level	1081 mm	<b>42.5"</b>	1081 mm	<b>42.5"</b>	1081 mm	<b>42.6"</b>	1081 mm	<b>42.6"</b>
5 Ground to top of tine at minimum height and fork level	105 mm	<b>4.1"</b>	105 mm	<b>4.1"</b>	105 mm	<b>4.1"</b>	105 mm	<b>4.1"</b>
6 Reach with arms horizontal and forks level	1676 mm	<b>66.0"</b>	1676 mm	<b>66.0"</b>	1676 mm	<b>66.0"</b>	1676 mm	<b>66.0"</b>
7 Reach with fork at maximum height	808 mm	<b>31.8"</b>	809 mm	<b>31.8"</b>	809 mm	<b>31.8"</b>	809 mm	<b>31.9"</b>
8 Ground to top of tine with arms horizontal and fork level	1861 mm	<b>73.3"</b>	1861 mm	<b>73.3"</b>	1861 mm	<b>73.3"</b>	1861 mm	<b>73.3"</b>
9 Ground to top of tine at maximum height and fork level	3945 mm	<b>155.3"</b>	3945 mm	<b>155.3"</b>	3945 mm	<b>155.3"</b>	3945 mm	<b>155.3"</b>
10 Overall height of fork at full lift (top of carriage to ground)	5190 mm	<b>204.3"</b>	5190 mm	<b>204.3"</b>	5190 mm	<b>204.3"</b>	5190 mm	<b>204.3"</b>
11 Clearance at full lift and maximum dump	2775 mm	<b>109.2"</b>	2576 mm	<b>101.4"</b>	2377 mm	<b>93.6"</b>	2178 mm	<b>85.7"</b>
12 Maximum discharge angle from horizontal		<b>41°</b>		<b>41°</b>		<b>41°</b>		<b>41°</b>
13 Carriage width	2540 mm	<b>100.0"</b>	2540 mm	<b>100.0"</b>	2540 mm	<b>100.0"</b>	2540 mm	<b>100.0"</b>
14 Carriage height	1335 mm	<b>52.5"</b>	1335 mm	<b>52.5"</b>	1335 mm	<b>52.5"</b>	1335 mm	<b>52.5"</b>
15 Outside tine width (maximum spread)	2176 mm	<b>85.7"</b>	2176 mm	<b>85.7"</b>	2176 mm	<b>85.7"</b>	2176 mm	<b>85.7"</b>
16 Outside tine width (minimum spread)	620 mm	<b>24.4"</b>	620 mm	<b>24.4"</b>	620 mm	<b>24.4"</b>	620 mm	<b>24.4"</b>
Tine width (single tine)	178 mm	<b>7.0"</b>	178 mm	<b>7.0"</b>	178 mm	<b>7.0"</b>	178 mm	<b>7.0"</b>
Tine thickness	89 mm	<b>3.5"</b>	89 mm	<b>3.5"</b>	89 mm	<b>3.5"</b>	89 mm	<b>3.5"</b>
Operating weight	23 122 kg	<b>50,960 lb</b>	23 184 kg	<b>51,097 lb</b>	23 247 kg	<b>51,235 lb</b>	23 309 kg	<b>51,372 lb</b>

Based on 2438 mm (96") carriage, Fusion coupler and Fusion pallet fork.

Static tipping loads and operating weight are based on the following loader configuration: L3 Michelin XHA tires, air conditioning, ride control, power train guard, full fluids, fuel tank, coolant, lubricants, and operator. Static tipping loads conform to the international standard as defined in ISO\* 14397-1 (Sept2007).

Specifications and ratings conform to the following standards: ISO 14397-1, SAE\*\* J1197, SAE J732, CEN\*\*\* EN 474-3.

The rated operating load for a loader equipped with a pallet fork is determined by:

- SAE J1197: 50% of full turn static tipping load or hydraulic limit.
- CEN EN 474-3: 60% of full turn static tipping load on rough terrain or hydraulic limit.
- CEN EN 474-3: 80% of full turn static tipping load on firm and level ground or hydraulic limit.

\*ISO — International Organization for Standardization

\*\*SAE — Society of Automotive Engineers

\*\*\*CEN — European Committee for Standardization

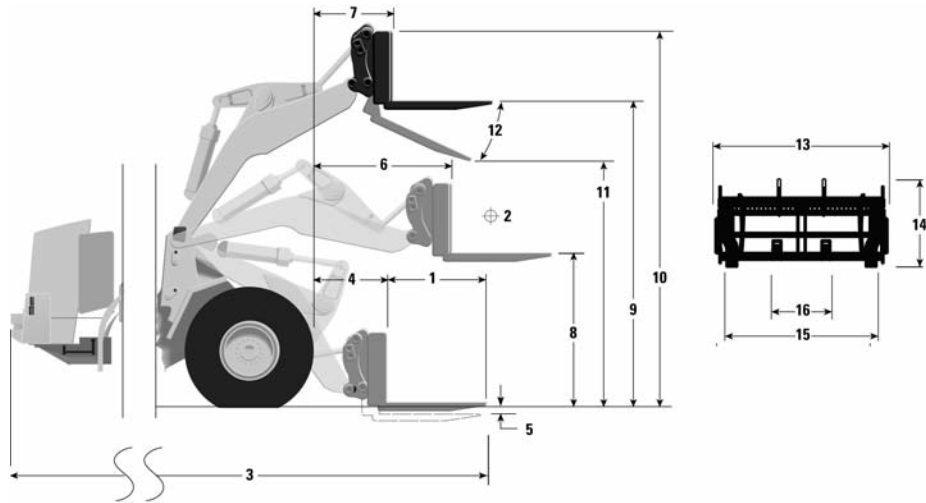

MODEL

972H

	1524 mm	60"	1829 mm	72"	2134 mm	84"	2438 mm	96"
1 Fork tine length	1524 mm	60"	1829 mm	72"	2134 mm	84"	2438 mm	96"
2 Load center	762 mm	30"	914 mm	36"	1067 mm	42"	1219 mm	48"
Tipping load — forks level straight	13 360 kg	29,445 lb	12 737 kg	28,073 lb	12 159 kg	26,799 lb	11 622 kg	25,615 lb
Tipping load — forks level articulated	11 678 kg	25,739 lb	11 126 kg	24,523 lb	10 613 kg	23,392 lb	10 136 kg	22,340 lb
Rated load (SAE J1197)	5839 kg	12,870 lb	5563 kg	12,261 lb	5307 kg	11,696 lb	5068 kg	11,170 lb
Rated load (CEN EN 474-3 rough terrain)	7007 kg	15,444 lb	6676 kg	14,714 lb	6368 kg	14,035 lb	6082 kg	13,404 lb
Rated load (CEN EN 474-3 firm and level ground)	9343 kg	20,591 lb	8901 kg	19,618 lb	8491 kg	18,714 lb	8109 kg	17,872 lb
3 Maximum overall length	9570 mm	376.8"	9875 mm	388.8"	10 180 mm	400.8"	10 485 mm	412.8"
4 Reach with forks at ground level	1242 mm	48.9"	1242 mm	48.9"	1242 mm	48.9"	1242 mm	48.9"
5 Ground to top of tine at minimum height and fork level	85 mm	3.3"	85 mm	3.3"	85 mm	3.3"	85 mm	3.3"
6 Reach with arms horizontal and forks level	1806 mm	71.1"	1806 mm	71.1"	1806 mm	71.1"	1807 mm	71.1"
7 Reach with fork at maximum height	761 mm	30.0"	761 mm	30.0"	761 mm	30.0"	761 mm	30.0"
8 Ground to top of tine with arms horizontal and fork level	1861 mm	73.3"	1861 mm	73.3"	1861 mm	73.3"	1861 mm	73.3"
9 Ground to top of tine at maximum height and fork level	4167 mm	164.1"	4167 mm	164.1"	4167 mm	164.1"	4167 mm	164.1"
10 Overall height of fork at full lift (top of carriage to ground)	5413 mm	213.1"	5413 mm	213.1"	5413 mm	213.1"	5413 mm	213.1"
11 Clearance at full lift and maximum dump	2998 mm	118.0"	2799 mm	110.2"	2600 mm	102.4"	2401 mm	94.5"
12 Maximum discharge angle from horizontal		41°		41°		41°		41°
13 Carriage width	2540 mm	100.0"	2540 mm	100.0"	2540 mm	100.0"	2540 mm	100.0"
14 Carriage height	1335 mm	52.5"	1335 mm	52.5"	1335 mm	52.5"	1335 mm	52.5"
15 Outside tine width (maximum spread)	2176 mm	85.7"	2176 mm	85.7"	2176 mm	85.7"	2176 mm	85.7"
16 Outside tine width (minimum spread)	620 mm	24.4"	620 mm	24.4"	620 mm	24.4"	620 mm	24.4"
Tine width (single tine)	178 mm	7.0"	178 mm	7.0"	178 mm	7.0"	178 mm	7.0"
Tine thickness	89 mm	3.5"	89 mm	3.5"	89 mm	3.5"	89 mm	3.5"
Operating weight	25 003 kg	55,106 lb	25 065 kg	55,243 lb	25 128 kg	55,381 lb	25 190 kg	55,518 lb

Based on 2438 mm (96") carriage, Fusion coupler and Fusion pallet fork.

Static tipping loads and operating weight are based on the following loader configuration: L3 Michelin XHA tires, air conditioning, ride control, power train guard, full fluids, fuel tank, coolant, lubricants, and operator. Static tipping loads conform to the international standard as defined in ISO\* 14397-1 (Sept2007).

Specifications and ratings conform to the following standards: ISO 14397-1, SAE\*\* J1197, SAE J732, CEN\*\*\* EN 474-3.

The rated operating load for a loader equipped with a pallet fork is determined by:

- SAE J1197: 50% of full turn static tipping load or hydraulic limit.
- CEN EN 474-3: 60% of full turn static tipping load on rough terrain or hydraulic limit.
- CEN EN 474-3: 80% of full turn static tipping load on firm and level ground or hydraulic limit.

\*ISO — International Organization for Standardization

\*\*SAE — Society of Automotive Engineers

\*\*\*CEN — European Committee for Standardization

For IT14G and 924H machines equipped with 15.5-25 L-2 tires subtract 39 mm (1.5") from lift height — add 39 mm (1.5") for below ground measurements — add 42 mm (1.7") for all reach measurements.

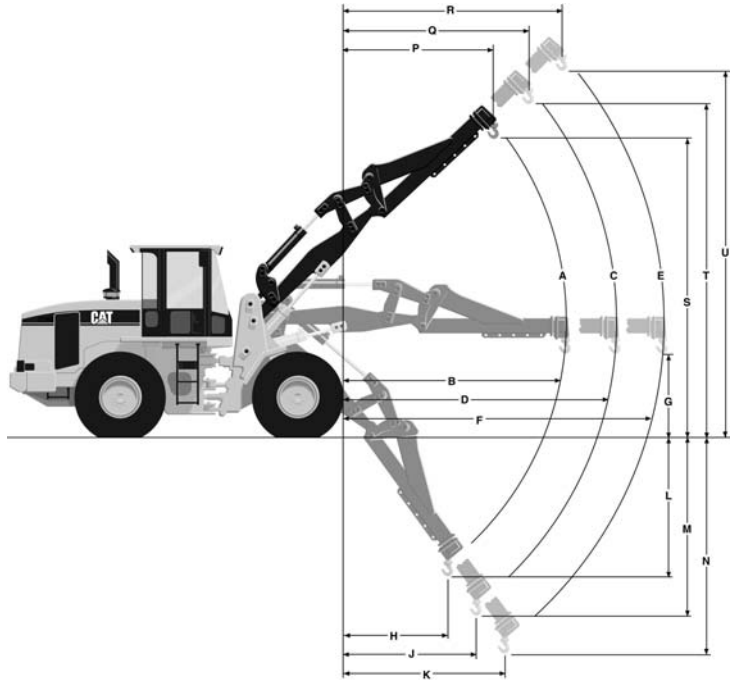

MODEL	IT14G		924H* Standard		924H* High Lift	
A Operating load (retracted) @ full articulation	1370 kg	<b>3021 lb</b>	1964 kg	<b>4320 lb</b>	1737 kg	<b>3821 lb</b>
B Reach horizontal (retracted)	3179 mm	<b>10'5"</b>	3251 mm	<b>10'8"</b>	3641 mm	<b>11'11"</b>
C Operating load (mid-position) @ full articulation	1076 kg	<b>2373 lb</b>	1560 kg	<b>3433 lb</b>	1405 kg	<b>3090 lb</b>
D Reach horizontal (mid-position)	4178 mm	<b>13'8"</b>	4249 mm	<b>13'11"</b>	4640 mm	<b>15'3"</b>
E Operating load (extended) @ full articulation	888 kg	<b>1958 lb</b>	1296 kg	<b>2851 lb</b>	1181 kg	<b>2598 lb</b>
F Reach horizontal (extended)	5178 mm	<b>17'0"</b>	5249 mm	<b>17'3"</b>	5640 mm	<b>18'6"</b>
G Clearance horizontal	1585 mm	<b>5'2"</b>	1855 mm	<b>6'1"</b>	1855 mm	<b>6'1"</b>
H Reach full down (retracted)	1514 mm	<b>4'11"</b>	833 mm	<b>2'9"</b>	1611 mm	<b>5'3"</b>
J Reach full down (mid-position)	2116 mm	<b>6'11"</b>	1139 mm	<b>3'9"</b>	2036 mm	<b>6'8"</b>
K Reach full down (extended)	2719 mm	<b>8'11"</b>	1446 mm	<b>4'9"</b>	2463 mm	<b>8'1"</b>
L Clearance full down (retracted)	1874 mm	<b>6'2"</b>	1890 mm	<b>6'2"</b>	1817 mm	<b>6'0"</b>
M Clearance full down (mid-position)	2670 mm	<b>8'9"</b>	2840 mm	<b>9'4"</b>	2721 mm	<b>8'11"</b>
N Clearance full down (extended)	3468 mm	<b>11'5"</b>	3792 mm	<b>12'5"</b>	3626 mm	<b>11'11"</b>
P Reach at maximum height (retracted)	1402 mm	<b>4'7"</b>	1454 mm	<b>4'9"</b>	1310 mm	<b>4'4"</b>
Q Reach at maximum height (mid-position)	1962 mm	<b>6'5"</b>	1929 mm	<b>6'4"</b>	1717 mm	<b>5'8"</b>
R Reach at maximum height (extended)	2522 mm	<b>8'2"</b>	2405 mm	<b>7'11"</b>	2125 mm	<b>7'0"</b>
S Clearance at maximum height (retracted)	5185 mm	<b>17'0"</b>	5733 mm	<b>18'10"</b>	6326 mm	<b>20'9"</b>
T Clearance at maximum height (mid-position)	6012 mm	<b>19'9"</b>	6611 mm	<b>21'8"</b>	7238 mm	<b>23'9"</b>
U Clearance at maximum height (extended)	6840 mm	<b>22'5"</b>	7491 mm	<b>24'7"</b>	8151 mm	<b>26'9"</b>
Tires	<b>17.5R25</b>		<b>20.5R25 (L-3)</b>		<b>20.5R25 (L-3)</b>	

\*VersaLink/Hook On.

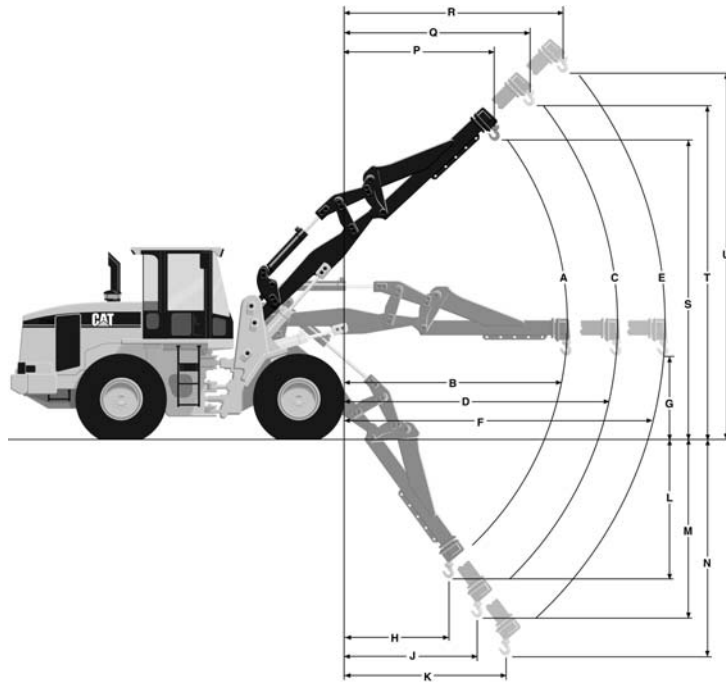

MODEL	930H* Standard		930H* High Lift		938H–972H**
A Rated operating load (retracted) @ full articulation	2333 kg	<b>5132 lb</b>	2072 kg	<b>4557 lb</b>	
B Reach horizontal (retracted)	3381 mm	<b>11'1"</b>	3775 mm	<b>12'5"</b>	
C Rated operating load (mid-position) @ full articulation	1868 kg	<b>4110 lb</b>	1687 kg	<b>3712 lb</b>	
D Reach horizontal (mid-position)	4380 mm	<b>14'4"</b>	4773 mm	<b>15'8"</b>	
E Rated operating load (extended) @ full articulation	1559 kg	<b>3431 lb</b>	1425 kg	<b>3135 lb</b>	
F Reach horizontal (extended)	5380 mm	<b>17'8"</b>	5774 mm	<b>18'11"</b>	
G Clearance horizontal	1842 mm	<b>6'1"</b>	1842 mm	<b>6'1"</b>	
H Reach full down (retracted)	1112 mm	<b>3'8"</b>	1520 mm	<b>5'0"</b>	
J Reach full down (mid-position)	1485 mm	<b>4'10"</b>	1852 mm	<b>6'1"</b>	
K Reach full down (extended)	1858 mm	<b>6'1"</b>	2185 mm	<b>7'2"</b>	
L Clearance full down (retracted)	1928 mm	<b>6'4"</b>	1970 mm	<b>6'6"</b>	
M Clearance full down (mid-position)	2854 mm	<b>9'4"</b>	2911 mm	<b>9'7"</b>	
N Clearance full down (extended)	3782 mm	<b>12'5"</b>	3855 mm	<b>12'8"</b>	
P Reach at maximum height (retracted)	1386 mm	<b>4'7"</b>	1494 mm	<b>4'11"</b>	
Q Reach at maximum height (mid-position)	1824 mm	<b>6'0"</b>	1984 mm	<b>6'6"</b>	
R Reach at maximum height (extended)	2263 mm	<b>7'5"</b>	2475 mm	<b>8'1"</b>	
S Clearance at maximum height (retracted)	5949 mm	<b>19'6"</b>	6380 mm	<b>20'11"</b>	
T Clearance at maximum height (mid-position)	6846 mm	<b>22'6"</b>	7250 mm	<b>23'9"</b>	
U Clearance at maximum height (extended)	7745 mm	<b>25'5"</b>	8122 mm	<b>26'8"</b>	
Tires	<b>20.5R25 (L-3)</b>		<b>20.5R25 (L-3)</b>		

\*VersaLink/Hook On.

\*\*For the latest information, visit Fusion.cat.com.

## SPECIFICATION DEFINITIONS FOR FRONT END LOADERS

Cat wheel and track loader specifications conform to Society of Automotive Engineers (SAE) definitions as expressed in standards J732 (JUN92), as follows:

### Description of Specification Machine

On wheel loaders the tire inflation pressure at which specifications are taken must be described in addition to the current written basic machine description. On track loaders the type of grouser must be specified.

### Hydraulic Cycle Times

- “Raise Time” — Time in seconds required to raise the bucket from level position on the ground.
- “Lower Time” — Time in seconds required to lower the empty bucket from the full height to a level position on the ground.
- “Dump Time” — Time in seconds required to move the bucket at maximum height from the maximum rollback position to full dump position while dumping the SAE loose material operating load.

### Breakout Force

“Breakout force,” pounds (and kilonewtons or kilograms) — the maximum sustained vertical upward force exerted 100 mm (4") behind the tip of the bucket cutting edge and achieved through the ability to lift and/or rollback about the specified pivot point under the following conditions:

- Loader on a hard level surface with transmission in neutral.
- All brakes released.
- Unit at standard operating weight — rear of loader not tied down.
- Bottom of cutting edge parallel to and not more than 20 mm (0.75") above or below the ground line.

- When bucket circuit is used the pivot point must be specified as the bucket hinge pin, and the unit blocked under the bucket hinge pin pivot point in order to minimize linkage movement.
- When the lift circuit is used, the pivot point must be specified as the lift arm hinge pin. Wheel loaders shall have front axle blocked to eliminate change in position of pivot pins due to tire deflection.
- If both circuits are used simultaneously, the dominating pivot point listed in (e) or (f) must be specified.
- If the circuit used causes the rear of the vehicle to leave the ground, then the vertical force value required to raise the rear of the vehicle is the breakout force.
- For irregular shaped buckets, the tip of the bucket cutting edge referred to above shall mean the farther forward point of the cutting edge.

The following are illustrations used (according to provisions of SAE J732 JUN92) to measure Cat Loader breakout forces.

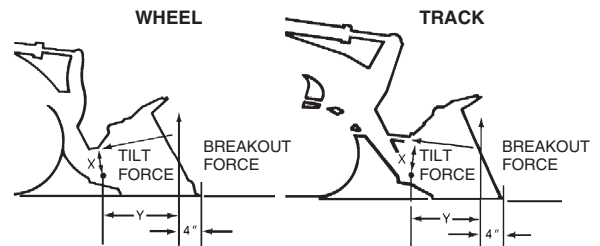

- Breakout force resulting from rollback:  
 $(\text{Tilt Force}) \times (\text{Dist. "X"}) = (\text{"Y" Dist.}) \times (\text{Breakout Force})$

$$\frac{(\text{Tilt Force}) \times (\text{Dist. "X"})}{\text{"Y" Dist.}} = \text{Breakout Force}$$

b. Breakout force resulting from bucket lift:

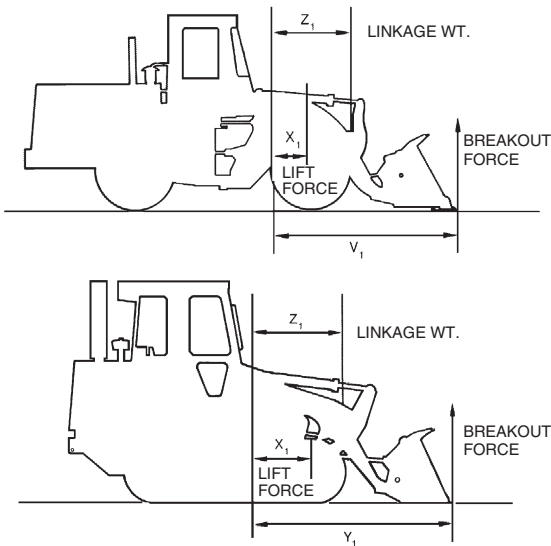

$$\begin{aligned} \text{(Lift Force)} \times \text{(Dist. "X}_1\text{")} &= \text{("Y}_1\text{"} \text{Dist.)} \times \text{(Breakout Force)} \\ &+ \text{(Linkage Wt.)} \times \text{(Dist. "Z}_1\text{")} \\ &+ \text{(Breakout Force)} \\ &\times \text{(Linkage Mechanical Advantage) "V}_1\text{"} \end{aligned}$$

$$\begin{aligned} \text{Breakout Force} &= \frac{\text{(Lift Force)} \times \text{(Dist. "X}_1\text{")} - \text{(Linkage Wt.)} \times \text{(Dist. "Z}_1\text{")}}{\text{(Dist. "Y}_1\text{")} + \text{(Dist. "V}_1\text{")} \times \text{(Linkage Mech. Advantage)}} \end{aligned}$$

**Static Tipping Load**

The minimum weight at center of gravity of "SAE Rated" load in bucket which will rotate rear of machine to a point where, on track loaders, front rollers are clear of the track and on wheel loaders, rear wheels are clear of the ground under the following conditions:

- Loader on hard level surface and stationary.
- Unit at standard operating weight.
- Bucket at maximum rollback position.
- Load at maximum forward position during raising cycle.
- For articulated wheel loaders, the test will be run both with frame straight (straight static tipping load) and fully turned to a specific angle (full turn static tipping load).
- Unit with standard equipment as described in specifications unless otherwise noted under the heading.

**Operating Load**

In order to comply with SAE standard J818 MAY87, the operating load of Wheel Loaders should not exceed 50% of the full turn Static Tipping load of the machine when equipped with attachments needed for the job. (For track loaders, operating load should not exceed 35% of the Static Tipping load rating.) See "Performance Data" of each machine in this handbook for increases to static tipping load by adding cab, counterweights, ripper-scarifier, etc.

The SAE operating load is not an indication of a wheel loader's rated payload. It takes into consideration only hydraulic lift and tipping capacity. There is no regard to structural and/or component lives, and for wheel loaders is measured on hard, moderately smooth and level operating surfaces.

**Carry Position**

SAE defines carry positions as: "The vertical distance from the ground to the center line of the bucket hinge pin, with the angle of approach at 15°." The sketch below illustrates this definition:

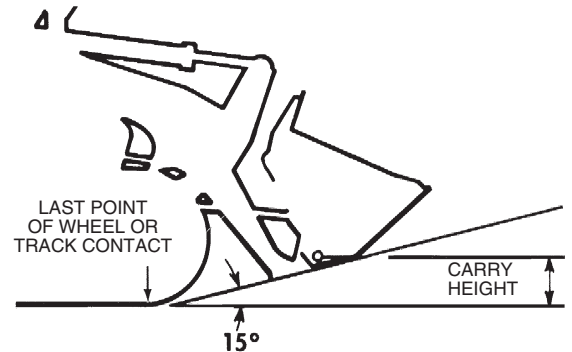

**Loader Clearance Circle**

SAE J732 JUN92 states that "minimum turning radius (over tire)" and "loader clearance circle" should be given for wheel loaders. Both are given on Cat specification sheets, including loader clearance circles for all available buckets for each machine.

**Digging Depth**

J732 JUN92 specifies digging depth as "the vertical distance in mm (inches) from the ground line to the bottom of the bucket cutting edge at the lowest position with the bucket cutting edge horizontal."

## SAE BUCKET RATING

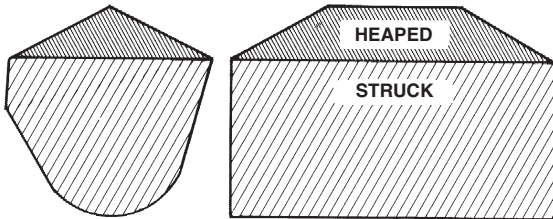

### SAE Bucket Capacities

*Struck capacity* is that volume contained in a bucket after a load is leveled by drawing a straight edge resting on the cutting edge and the back of the bucket.

*Heaped capacity* is a struck capacity plus that additional material that would heap on the struck load at a 2:1 angle of repose with the struck line parallel to the ground.

SAE J742 (FEB85) specifies that the addition of any auxiliary spill guard to protect against spillage which might injure the operator will not be included in bucket capacity ratings. Buckets with irregular shaped cutting edges (vee edge) the strike plane should be drawn at one-third the distance of the protruding portion of the cutting edge. Cat rock buckets are built with integral see-through rock guards. Cat light material buckets come standard with bolt-on edges. These features which add to actual bucket capacity are included in published ratings.

### Dump Height

SAE J732 JUN92 specifies that dump height is the vertical distance from the ground to the lowest point of the cutting edge with the bucket hinge pin at maximum height and the bucket at a 45° dump angle. Dump angle is the angle in degrees that the longest flat section of the inside bottom of the bucket will rotate below horizontal.

## SELECTING A MACHINE

### Steps in selecting the proper size loader:

1. Determine production required or desired.
2. Determine loader cycle time and cycles per hour.  
A machine size must be assumed to select a basic cycle time.

3. Determine required payload per cycle in loose cubic yards and pounds (meters and kilograms).
4. Determine bucket size needed.
5. Make machine selection using bucket size and payload as criteria to meet production requirements.
6. Compare the loader cycle time used in calculations to the cycle time of the machine selected. If there is a difference, rework the process beginning at step 2.

### 1. Production Required

The production required of a wheel or track loader should be slightly greater than the production capability of the other critical units in the earth or material moving system. For example, if a hopper can handle 300 tons per hour, a loader capable of slightly more than 300 tons should be used. Required production should be carefully calculated so the proper machine and bucket selections are made.

### 2. Loader Cycle Times

When hauling loose granular material on a hard smooth operating surface, a .45-.55 minute basic cycle time is considered reasonable for Cat articulated loaders with a competent operator. This includes load, dump, four reversals of direction, full cycle of hydraulics and minimum travel.

Material type, pile height, and other factors may improve or reduce production, and should be added to or subtracted from the basic cycle time when applicable.

When hauls are involved, obtain the haul and return portion of the cycle from the estimated travel chart (this section). Add the haul and return times to the estimated basic cycle time to obtain total cycle time.

### CYCLE TIME FACTORS

A basic cycle time (Load, Dump, Maneuver) of .45-.55 minutes is average for an articulated loader [the basic cycle for large loaders, 3 m<sup>3</sup> (4 yd<sup>3</sup>) and up, can be slightly longer], but variations can be anticipated in the field. The following values for many variable elements are based on normal operations. Adding or subtracting any of the variable times will give the total basic cycle time.

Minutes added (+)  
 or Subtracted (-)  
 From Basic Cycle

- Machine*  
 — Material handler . . . . . -.05
- Materials*  
 — Mixed . . . . . +.02  
 — Up to 3 mm (1/8 in). . . . . +.02  
 — 3 mm (1/8 in) to 20 mm  
 (3/4 in). . . . . -.02  
 — 20 mm (3/4 in) to 150 mm  
 (6 in) . . . . . .00  
 — 150 mm (6 in) and over . . . . . +.03 and Up  
 — Bank or broken . . . . . +.04 and Up
- Pile*  
 — Conveyor or Dozer piled 3 m  
 (10 ft) and up . . . . . .00  
 — Conveyor or Dozer piled 3 m  
 (10 ft) or less . . . . . +.01  
 — Dumped by truck . . . . . +.02
- Miscellaneous*  
 — Common ownership of trucks  
 and loaders . . . . . Up to -.04  
 — Independently owned  
 trucks . . . . . Up to +.04  
 — Constant operation . . . . . Up to -.04  
 — Inconsistent operation . . . . . Up to +.04  
 — Small target . . . . . Up to +.04  
 — Fragile target . . . . . Up to +.05

Using actual job conditions and the above factors, total cycle time can be estimated. Convert total cycle time to cycles per hour.

$$\text{Cycles per hour at } 100\% \text{ Efficiency} = \frac{60 \text{ min}}{\text{Total Cycle Time in Minutes}}$$

Job efficiency is an important factor in machine selection. Efficiency is the actual number of minutes worked during an hour. Job efficiency accounts for bathroom breaks and other work interruptions.

$$\begin{array}{l} \text{Cycles per hour} \\ \text{at 50 minutes} \\ \text{per hour} \\ \text{(83\% efficiency)} \end{array} = \begin{array}{l} \text{Cycles per hour} \\ \text{at 100\%} \\ \text{efficiency} \end{array} \times \begin{array}{l} \text{50 min} \\ \text{actual work} \\ \text{time} \\ \hline \text{60 min hour} \end{array}$$

**TRUCK LOADING**

Average loader cycle times

914G-962H . . . . .	0.45-0.50 min
966H-980H . . . . .	0.50-0.55 min
988H-990H . . . . .	0.55-0.60 min
992K-994F . . . . .	0.60-0.70 min

**3. Required Payload Per Cycle**

Required payload per cycle is determined by dividing required hourly production by the number of cycles per hour.

**4. Bucket Selection**

After required payload per cycle has been calculated, the payload should be divided by the loose cubic yard (meter) material weight to determine number of loose cubic yards (meters) required per cycle.

The bulk of material handled does not weigh 1800 kg/m<sup>3</sup> (3000 lb/yd<sup>3</sup>), so a reasonable knowledge of material weight is necessary for accurate production estimates. The Tables Section has average weight for certain materials when actual weights are not known.

The percentage of rated capacity a bucket carries in various materials is estimated below. The bucket size required to handle the required volume per cycle is found with the aid of the percentage of rated bucket capacity called "Bucket Fill Factor."

The bucket size needed is determined by dividing loose cubic meters (or yards) required per cycle by the bucket fill factor.

$$\text{Bucket size} = \frac{\text{Volume Required/Cycle}}{\text{Bucket Fill Factor}}$$

**BUCKET FILL FACTORS**

The following indicates the approximate amounts of material as a percent of rated bucket capacity which will actually be delivered per bucket per cycle. This is known as "Bucket Fill Factor."

Loose Material	Fill factor
Mixed moist aggregates . . . . .	95-100%
Uniform aggregates up to 3 mm (1/8 in). . . . .	95-100
3 mm (1/8 in) to 9 mm (3/8 in). . . . .	90-95
12 mm (1/2 in) to 20 mm (3/4 in). . . . .	85-90
24 mm (1.0 in) and over . . . . .	85-90



### Blasted Rock

Well blasted . . . . .	80-95%
Average . . . . .	75-90
Poor . . . . .	60-75

### Other

Rock dirt mixtures . . . . .	100-120%
Moist loam . . . . .	100-110
Soil, boulders, roots . . . . .	80-100
Cemented materials . . . . .	85-95

**NOTE:** Fill factors on wheel loaders are affected by bucket penetration, breakout force, rackback angle, bucket profile and ground engaging tools such as bucket teeth or bolt-on replaceable cutting edges.

### Example:

12 mm (1/2 in) material and 3 m<sup>3</sup> (4 yd<sup>3</sup>) bucket.  
 .90 × 3 m<sup>3</sup> = 2.75 Loose m<sup>3</sup> delivered per cycle.  
 .90 × 4 yd<sup>3</sup> = 3.6 Loose yd<sup>3</sup> delivered per cycle.

**NOTE:** Check the static tipping load on the specific machine to determine if bucket load is in fact a safe operating load.

### Bucket Selection

$$\text{Tons Required/Cycle} = \frac{\text{Tons Required/Hour}}{\text{CyclesHour}}$$

$$\text{Kg (Pounds) Required/Cycle} = \frac{\text{Tons Required/Cycle}}{\times 907 \text{ kg (2000 lb)}}$$

$$\text{Volume Required/Cycle} = \frac{\text{kg (Pounds) Cycle}}{\text{Material Weight kg/m}^3 \text{ (lb/yd}^3)}$$

Always select a machine with a greater capacity than the calculated required operating capacity. For most applications, payload above recommended and excessive counterweight can hinder machine performance and reduce dynamic stability and machine life.

For optimum performance in fast cycling situations such as truck loading, operating loads should not exceed the recommended capacity. To provide extra stability, calcium chloride (CaCl<sub>2</sub>) ballast may be desired when operating at recommended operating load, see SAE Loader rating pages in this section. For specific stability data and optional tire sizes, see the "Performance Data" pages in this section.

When selecting special application buckets, such as multi-purpose and side dump the additional bucket weight must be deducted from recommended capacity.

Specific circumstances may involve other conditions which would also affect loader capacity. Because of the greatly varied applications and conditions, your Cat dealer should be contacted for guidance.

### Example problem:

#### JOB CONDITIONS

Application	Truck loading
Production Required	450 metric ton (496 Tons) per hour
Material	9 mm (3/8") gravel in 6 m (20 ft) high stockpile
Density	1660 kg/m <sup>3</sup> (2800 lb/yd <sup>3</sup> )

Trucks are 6-9 m<sup>3</sup> (8-12 yd<sup>3</sup>) capacity and are owned by three contractors. Loading is constant. Hard level surface for loader maneuvering.

1. **PRODUCTION REQUIRED:** Given
2. **CYCLE TIME:** Assume loader size between 914G and 962H for initial choice of basic cycle.  
 (Refer to Cycle Time Factors in this section)
 

Independent trucks	.04 min
Basic Cycle	.50 min
Material	-.02 min
Independent trucks	+.04 min
Constant operation	-.02 min
<b>Total Cycle</b>	<b>.50 min</b>

**NOTE:** Load and carry times not required in total cycle.

$$\begin{aligned} \text{Cycles/hr at 83\% efficiency} &= 120 \text{ cycles/hr} \times \frac{50 \text{ min actual work time}}{60 \text{ min per hr}} \\ &= 100 \text{ cycles/hr} \end{aligned}$$

3. **VOLUME REQUIRED PER CYCLE**  
 (Density in tons)  
 Density in this example was given. When not given, refer to Tables Section to obtain an estimated density for the material being handled.

$$\text{Metric: } \frac{1660 \text{ kg/m}^3}{1000 \text{ kg/ton}} = 1.66 \text{ ton/m}^3$$

$$\text{English: } \frac{2800 \text{ lb/yd}^3}{2000 \text{ lb/ton}} = 1.4 \text{ tons/yd}^3$$

**Production Rate Required**

$$\text{Metric: } \frac{450 \text{ tons/hr}}{1.66 \text{ tons/m}^3} = 271 \text{ m}^3/\text{hr}$$

$$\text{English: } \frac{496 \text{ tons/hr}}{1.4 \text{ tons/yd}^3} = 354 \text{ yd}^3/\text{hr}$$

**Volume Required per Cycle**

$$\text{Metric: } \frac{271 \text{ m}^3/\text{hr}}{100 \text{ cycles/hr}} = 2.71 \text{ m}^3/\text{cycle}$$

$$\text{English: } \frac{354 \text{ yd}^3/\text{hr}}{100 \text{ cycles/hr}} = 3.54 \text{ yd}^3/\text{cycle}$$

4. **DETERMINE BUCKET SIZE**

**BUCKET FILL FACTOR**

The volume of material required per cycle has been determined. Because of varying material fill factors, buckets do not always carry their rated load, a larger capacity bucket may be needed to carry the volume required. For fill factors, refer to Bucket Fill Factor Chart in this section.

**Rated Bucket Capacity Required (Heaped)**

$$\frac{2.71 \text{ m}^3/\text{cycle}}{.95 \text{ fill factor}} = 2.85 \text{ m}^3$$

$$\frac{3.54 \text{ yd}^3/\text{cycle}}{.95 \text{ fill factor}} = 3.73 \text{ yd}^3$$

A 2.9 m<sup>3</sup> (3.75 yd<sup>3</sup>) bucket would provide the required capacity.

5. **MACHINE SELECTION**

The bucket size required and material density lead to the choice of a 950H with a 2.9 m<sup>3</sup> (3.75 yd<sup>3</sup>) General Purpose Bucket (see bucket selection guide pages which follow.)

Finally, SAE payload criteria must be satisfied as follows:

The required operating capacity must not exceed one-half of the full turn static tipping load of the loader as equipped with a specific bucket.

The required operating capacity of the machine is determined by the volume the machine will carry per load times the density.

$$2.9 \text{ m}^3 \times 1660 \text{ kg/m}^3 = 4814 \text{ kg}$$

$$(3.75 \text{ yd}^3 \times 2800 \text{ lb/yd}^3 = 10,500 \text{ lb})$$

One half of full turn static tipping load for the 950H with a 2.9 m<sup>3</sup> (3.75 yd<sup>3</sup>) General Purpose Bucket is 5410 kg (11,925 lb). SAE criteria is satisfied.



**An Alternative Method of Machine Selection**

Another method of selecting the right Wheel Loader and bucket to meet production requirements is by use of the nomographs on the following pages. The method is quicker and easier than the preceding example because it does not require as many calculations, yet the accuracy is about the same within the normal limits of input data.

Be careful when entering and reading data from the nomographs because some scales increase from bottom to top, while others are the reverse. Do not be overly concerned with the precision as affected by pencil line width or reading to the hundredth of a m<sup>3</sup> (yd<sup>3</sup>). Remember that bucket fill factor, material density and cycle time are at best close estimates.

Example problem:

A Wheel Loader must produce 230 m<sup>3</sup> (300 yd<sup>3</sup>) per hour in a truck loading application. Estimated cycle time is .6 minutes, working 45 minutes per hour. Bucket fill factor is 95% and material density is 1780 kg/m<sup>3</sup> (3000 lb/yd<sup>3</sup>).

Determine bucket size and machine model.

**Solution:**

At full efficiency, the Wheel Loader will cycle 100 times per hour. Since only an average of 45 minutes are available, only 75 cycles will be completed.

Starting on Scale A at 75 cycles per hour draw a straight line intersecting 230 m<sup>3</sup>/hr (300 yd<sup>3</sup>/hr) on Scale B and extending it on to Scale C giving 3 m<sup>3</sup>/cycle (4 yd<sup>3</sup>/cycle) required payload. Follow solution steps 1-10.

# Wheel Loaders Integrated Toolcarriers

## Production and Machine Selection Nomograph

- To find required bucket payload and bucket size

1. Enter required hourly production on Scale B  
230 m<sup>3</sup>/hr (300 yd<sup>3</sup>/hr).
2. Enter cycles per hour on Scale A (60 ÷ .6 = 100  
× .75 = 75 cycles/hr).
3. Connect A through B to C. This shows a required  
payload of 3 m<sup>3</sup> (4 yd<sup>3</sup>) per cycle.
4. Enter estimated bucket fill factor on Scale D  
(0.95).
5. Connect C through Scale D to E for required bucket  
size 3 m<sup>3</sup> (4 yd<sup>3</sup>).
6. Transfer cycles per hour Scale A and required  
payload Scale C to the following page.

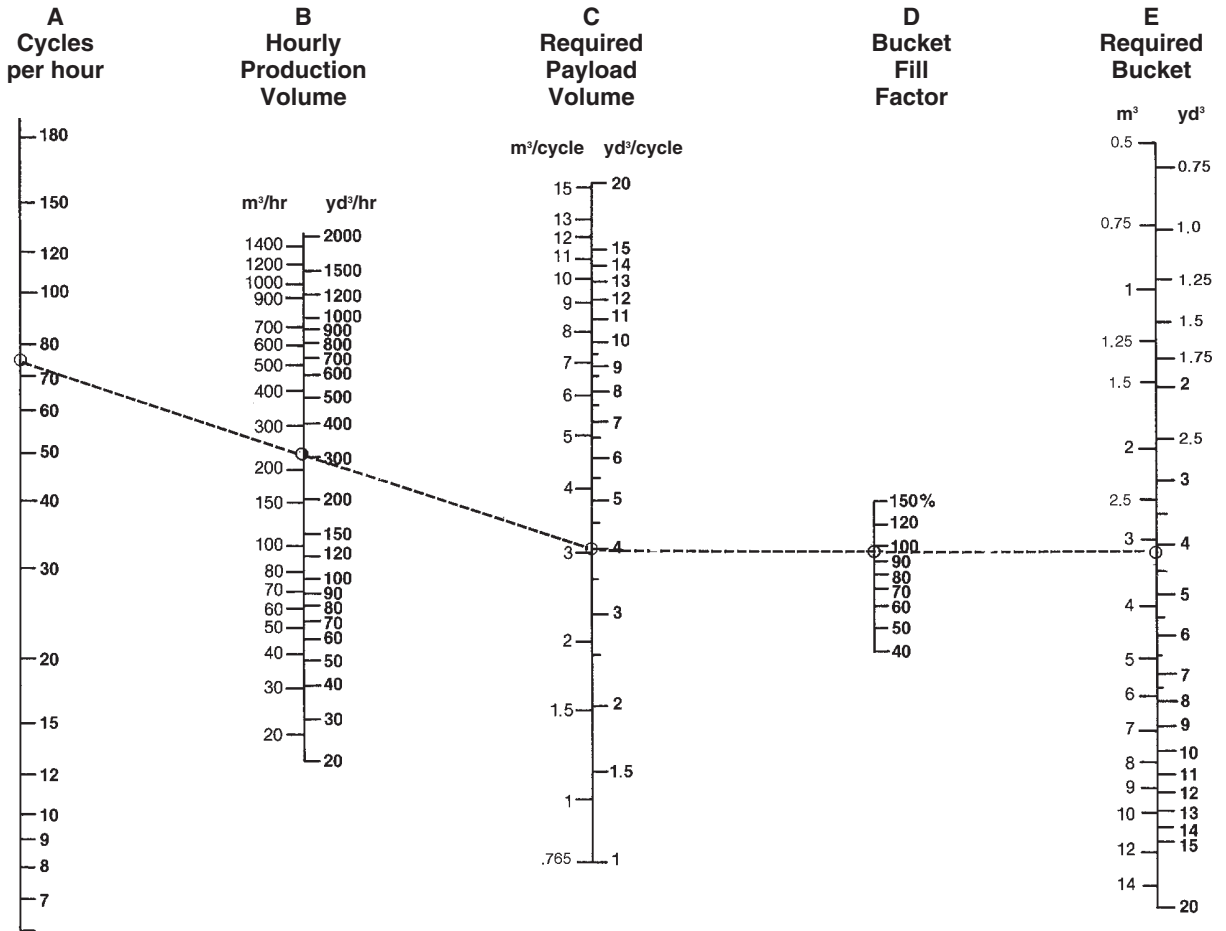

# Production and Machine Selection Nomograph

● To find payload weight and tons per hour

# Wheel Loaders Integrated Toolcarriers

- Enter material density on Scale F 1780 kg/m<sup>3</sup> (3000 lb/yd<sup>3</sup>).
- Connect C through Scale F to Scale G to give payload weight per cycle 5300 kg (11,500 lb).
- Compare Scale G quantity 5300 kg (11,500 lb) with recommended machine working range listed on the following bucket selection pages.

Operating capacity for the 950H with 3.1 m<sup>3</sup> (4 yd<sup>3</sup>) bucket is dependent on material density and bucket capacity (see bucket selection pages that follow).

- For hourly tonnage, draw a straight line from Scale G through Scale A to Scale I 400 metric tons (450 U.S. tons).

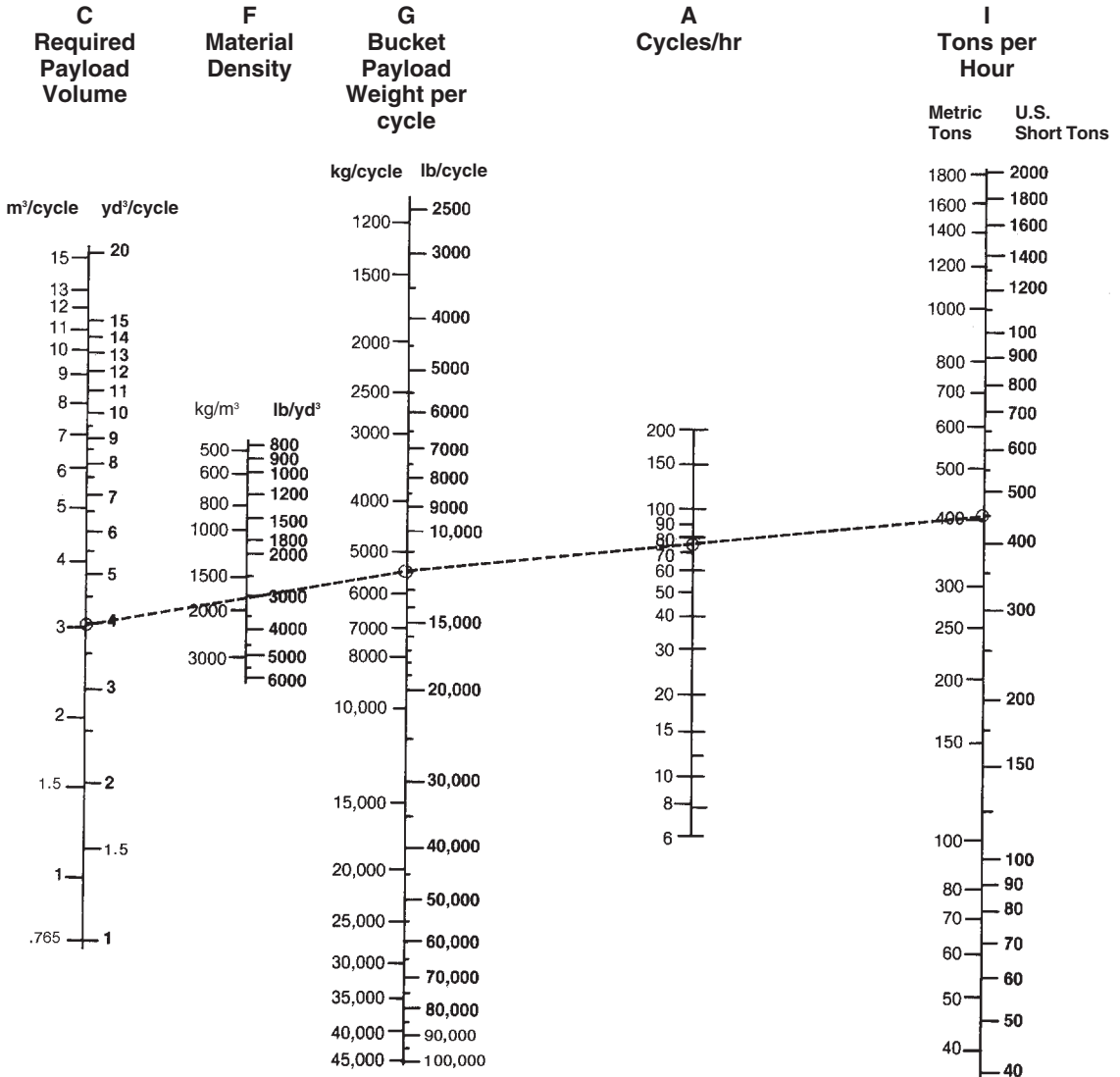

**MACHINE/ATTACHMENT SELECTION**

The Integrated Toolcarrier’s versatility and the wide range of attachments makes the “single machine fleet” concept highly attractive to an increasing number of users.

A Job Analysis helps identify applications, work requirements, material handling parameters and the current working method. Thoroughly research each element in the following chart, the gathered information will help select the proper Integrated Toolcarrier System.

**JOB ANALYSIS METHOD**

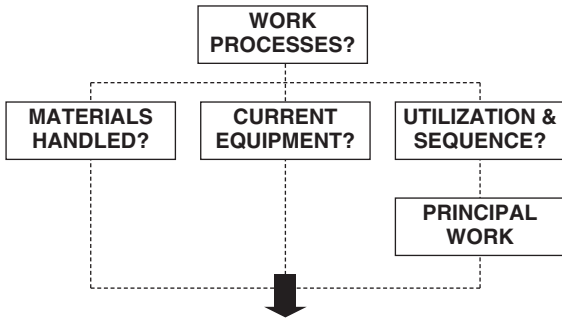

- **APPROPRIATE INTEGRATED TOOLCARRIER MODEL SIZE**
- **NECESSARY ATTACHMENTS**

**Work Processes:**

The first step in the job analysis is to identify all work processes from start to finish. Key questions outlined below will begin to indicate the required attachments and potential Integrated Toolcarrier applications.

- What kinds of work are performed: (e.g., dozing, loading, stacking, digging, sweeping, handling special materials, etc.)
  - ... in site preparation?
  - ... below ground level?
  - ... at ground level?
  - ... above ground level?
  - ... in landscaping?
  - ... in maintenance equipment yard?
  - etc.
- What work is done manually that could be done with an Integrated Toolcarrier?
- What are the work conditions?:
  - ... underfoot?
  - ... grades?
  - ... tight quarters?
  - ... time restraints?
  - ... climate?
  - etc.

**Materials Handled:**

Examining the materials handled will assist in determining necessary attachments. Sizes and weights of material(s) handled will indicate the appropriate Integrated Toolcarrier model by defining lift and reach requirements. Concentrate on the material flow at the job site — the point of origin as well as the final destination for the various materials will undoubtedly have material handling requirements.

- What kinds of materials are handled (e.g. snow, earth, bricks, chemicals, pipe, logs, etc.)
- What form are the materials handled in: bulk? palletized?
- How much does each weigh?
- What are the dimensions of each?
- What are the... movement parameters:
  - ... dozed what distance?
  - ... load and carried what distance?
  - ... lifted how high?
  - ... placed below ground level?
  - ... placed what distance from machine?

**Current Equipment:**

If determining material weight is not possible, much information can be determined from looking at the current equipment fleet. This will suggest required performance capabilities such as lifting capacity.

- Machines currently doing the work (e.g. wheel loaders, lift trucks, sweepers, light capacity cranes, snow plows, etc.)?
- What special (maximum) capabilities does each machine have (production, lift height, load capacity, width/height dimensions, reach, turning radius, travel speed, etc.)?
- To what extent are each machine's maximum capabilities used?
- What are owning/operating costs of each?

**Utilization & Sequence:**

Utilization implies how often the current machines are used and what will be the utilization factors for the Integrated Toolcarrier with each individual attachment. Sequence implies what order these tasks are accomplished in and if two or more machines operate at the same time. This portion of the job analysis should assist in comparing economies of various systems. Other important considerations may be the number of operators needed, storage space, reduced maintenance requirements, etc.

- How often (what percent) is each machine used?
- How often and when does it sit idle?
- How often and when do two or more machines work at the same time?
- Can the operation be changed to permit single machine operation?

**Principal Work:**

Utilization and sequence will indicate the principal work the Integrated Toolcarrier will do, further assisting in attachment and model sizing and selection. The basic machine/tool package should be able to handle the toughest, most frequently performed jobs for the primary application. Secondary tools can have a little more "give and take" in their performance capabilities than the primary tool.

- What work can be accomplished by an Integrated Toolcarrier?
- What work will take up the majority of Integrated Toolcarrier time?
- What work will use the maximum static tipping capabilities of the Integrated Toolcarrier?
- What high cost (owning and operating) and/or low utilization machines can be replaced by an Integrated Toolcarrier?

**Additional Tips for Tool Sizing and Selection**

Tool selection will principally concern hydraulic power requirements and static tipping load considerations. The standard tools offered by Caterpillar can be used on any Integrated Toolcarrier machine with little difficulty. However, tools such as the hydraulic broom, claws, blades and asphalt cutter will require additional consideration before proposing a system to the customer.

## Fork Rating

Table indicates rated pallet fork load at standard machine configuration, 600 mm (24") load center, 1200 mm (3'11") fork on IT14G-930H, see operator manual to determine rated load for vehicle configuration being used.

Model	kg	lb	Model	kg	lb
<b>IT14G</b>	1870	<b>4123</b>	<b>930H Standard</b>	3179	<b>6994</b>
<b>924H Standard</b>	2724	<b>5993</b>	<b>930H High Lift</b>	2739	<b>6026</b>
<b>924H High Lift</b>	2329	<b>5124</b>			

## Bucket Rating

Bucket capacity, SAE J742 FEB85 (nominally heaped)

Table indicates rated load at vehicle configuration noted by the asterisks. See operator manual to determine rated load for vehicle configuration being used.

1.4 m <sup>3</sup> (1.75 yd <sup>3</sup> ) with Bolt-on Cutting Edge		
<b>IT14G*</b>	2273 kg	<b>5000 lb</b>
1.8 m <sup>3</sup> (2.35 yd <sup>3</sup> ) with Bolt-on Cutting Edge		
<b>924H** Standard</b>	3638 kg	<b>8004 lb</b>
<b>924H** High Lift</b>	2958 kg	<b>6508 lb</b>
2.0 m <sup>3</sup> (2.6 yd <sup>3</sup> ) with Bolt-on Cutting Edge		
<b>924H** Standard</b>	3549 kg	<b>7808 lb</b>
<b>924H** High Lift</b>	2875 kg	<b>6325 lb</b>
2.1 m <sup>3</sup> (2.75 yd <sup>3</sup> ) with Bolt-on Cutting Edge		
<b>930H** Standard</b>	3990 kg	<b>8778 lb</b>
<b>930H** High Lift</b>	3162 kg	<b>6956 lb</b>
2.3 m <sup>3</sup> (3.0 yd <sup>3</sup> ) with Bolt-on Cutting Edge		
<b>930H** Standard</b>	3935 kg	<b>8657 lb</b>
<b>930H** High Lift</b>	3111 kg	<b>6844 lb</b>
2.5 m <sup>3</sup> (3.25 yd <sup>3</sup> ) with Bolt-on Cutting Edge		
<b>930H** Standard</b>	3893 kg	<b>8565 lb</b>
<b>930H** High Lift</b>	3071 kg	<b>6756 lb</b>

\*Specifications shown are for high-speed version IT14G and include lubricants, full fuel tank, ROPS cab, 80 kg (176 lb) operator, standard 250 kg (550 lb) counterweight and 17.5-R25 (L-2 equivalent) tires.

\*\*Specifications shown include lubricants, full fuel tank, limited slip axles, heavy duty rear brakes, optional counterweights, additional guarding, ROPS cab with A/C, 80 kg (176 lb) operator and 20.5-R25 (L-3) tires.

The charts explain each machine's maximum payload. The maximum material density would be determined by dividing the payload by the bucket capacity. If the actual material density exceeds the recommended material density, the process should be repeated to select the properly sized bucket.

A similar procedure would be used with the forks and material handling arm to determine maximum recommended lifting capacity and/or required IT model size.

## Pallet Fork

The pallet fork will fulfill many material handling needs. A modified Class 3 fork carriage provides visibility to the tines for precision pallet work. This carriage with non-standard spacing accepts many Class 3 lift truck attachments.

Pallet fork rated operating loads are based on the following:

SAE J1197 FEB91: 50% of the full turn static tipping load or the hydraulic/structural limitations.

CEN 474-3 (European standard): 60% of the full static tipping load on rough terrain or the hydraulic/structural limitations. 80% of the full turn static tipping load on firm, level ground or the structural/hydraulic limitation. Other local, regional or international guidelines may also apply.

If operation is on rough ground these criteria may need modification. In this instance, the size and rating of existing equipment should be considered.

Sizing for pallet work generally consists of answering the following questions.

1. What are the average loaded pallet dimensions?
2. Lift Capacity — what capacity is required to lift and move the average pallet load? The maximum pallet load?
3. Lift Height — can the machine reach the top level of the standard pallet stack? What are the maximum reach, lift and height requirements?
4. Maneuverability — can the machine work around the current aisle configuration? In the stacking aisles? Main aisles? Intersecting aisles? Are 90° turns required in any aisle for material placement?
5. Length — what tine length is required to fit the commonly used pallets? (1219 mm [4'0"] tines are standard length for most palletized material.)
6. Any machine height restrictions?
7. Any special fork configurations required?

Lift capacity, lift height, aisle configuration and tine length are the most important considerations in recommending a pallet handling machine.

Example problem:

The following example applies the job analysis method to a work situation.

**Sewer & Water Contractor**

Sets water lines (152 mm-610 mm [6 in-24 in] iron pipe), sanitary sewer lines (152 mm-457 mm [6 in-18 in] PVC) and storm sewer lines (610 mm-1067 mm [24 in-42 in] concrete pipe) primarily in urban areas ... often-times across or down existing streets.

**Materials**

- Loam/Clay: 1600 kg/m<sup>3</sup> (2700 lb/yd<sup>3</sup>) loose density Bedding (Gravel): 1900 kg/m<sup>3</sup> (3200 lb/yd<sup>3</sup>) loose density
- Water Pipe: 610 mm (24 in) push-on joint ductile iron, 6.1 m (20 ft) sections, 1309 kg (2885 lb) 215 kg/m (144.3 lb/ft) × 6.1 m (20 ft) See trenching pages in the Excavator backhoe section.
- Storm Sewer: 1067 mm (42 in), Wall B, concrete pipe, 1.5 m (5 ft) sections, 1556 kg (3430 lb) 1021 kg/m (686 lb/ft × 5 ft) See trenching pages in the Excavator backhoe section.

**Manhole**

- Boxes: 1361 kg (3000 lb)

WHAT INTEGRATED TOOLCARRIER MODEL SHOULD BE RECOMMENDED?

WHICH ATTACHMENTS?

<b>Work Processes</b>	<b>Integrated Toolcarrier Attachment Possibilities</b>
Bundled PVC and individual concrete/iron pipe-loaded/unloaded (yardsite) and strung along trench	Forks/Material Handling Arm
Unload, handle, set manhole boxes	Material Handling Arm
Excess excavated material truck loaded	Bucket
Bedding material handled/placed	Bucket
Trench backfilled	Bucket/Blade
Trench compaction	Compactor Wheel
Rough and finish grading	Bucket/Blade
Street cleanup	Bucket/Broom
Pavement removal	Rebar Snips/Asphalt Cutter

**Current Equipment**

	<b>Utilization</b>
Cat 225	.90%
Champ CB607 lift truck, 3175 kg (7000 lb) capacity	.15%
Deere 444 with 1.1 m <sup>3</sup> (1.5 yd <sup>3</sup> ) G.P. bucket	.60%
Rosco D-50 sweeper	one half hour/day
Rammax 1361 kg (3000 lb) self-propelled trench compactor	.25%

**Machine sizing**

1350 mm (53 in) Forks

**Operating Load at Full Turn\***

<b>Model</b>	<b>kg</b>	<b>lb</b>
<b>IT14G</b>	1810	5991
<b>924H</b>	2616	5755
<b>930H Standard</b>	3058	6728
<b>930H High Lift</b>	2639	5806
Water pipes:		IT14G ... 1 pipe — no problem
1309 kg (2885 lb)		924H ... 1 pipe — no problem
		930H ... 1 pipe — no problem
Storm sewer pipes:		IT14G ... 1 pipe — no problem
1556 kg (3430 lb)		924H ... 1 pipe — no problem
		930H ... 1 pipe — no problem

\*Note that the most conservative operating load (SAE J1197 FEB91) is used here. The rated operating load for some competitive machines with pallet forks will be based upon European standard CEN 474-3, assuming operation on firm and level ground (i.e. using 80% of full turn static tipping load).



### Performance Series Buckets

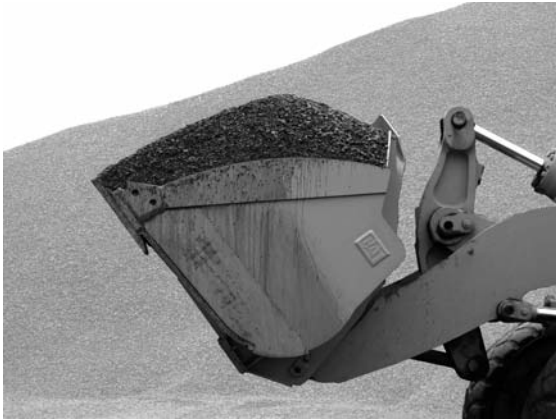

Performance Series Buckets utilize a system-based approach to balance bucket shape against the machine's linkage, weight, lift and tilt capacities. The result is a bucket optimized for performance and productivity, and intended for use in production applications. Performance Series Buckets for Wheel Loaders are designed for use in truck loading, stockpiling and load-and-carry applications. Performance is improved over current buckets in these production applications with materials such as sand, gravel and aggregates. Performance Series General Purpose buckets are available as pin-on for 972H, 980H and 988H Wheel Loaders.

#### Loads Easy

Proven design characteristics improve material flow into the bucket and improve material retention during transport. In some situations, the number of passes required to fill a truck is reduced. Performance Series Buckets are designed for optimum performance on the machine. Profile changes (over current buckets) improve loadability and make Performance Series Buckets machine-specific.

#### Fuel Efficient

Performance Series Buckets have a longer floor — easily digging through the pile. Less time in the pile equals less fuel consumed.

#### Higher Fill Factors

When comparing buckets of the same rated capacity, Performance Series Buckets have higher fill factors — up to 115%.

#### Move More Material with the Same Rated Capacity

More material can be moved with a Performance Series Bucket compared to a same-size rated capacity current bucket. Likewise, a smaller Performance Series Bucket can be utilized to move the same amount of material as a larger rated capacity current bucket.

#### Carries More

##### Productive

Bucket shape and strike plane angle are designed for material retention and consistent load sizes. More material loads into the bucket and is carried all the way to the truck, hopper or stockpile.

A spill guard diverts overflow away from hinge pins, lift arms, hydraulic cylinders and tilt sensors helping to protect these areas of the machine.

#### Bucket Specifications

Performance Series Buckets are designed to bring optimum performance to a specific machine. Profile changes over current buckets allow higher fill factors and increased production.

#### Incompatibility on the 966H

Because 972H Performance Series Buckets are designed specifically for performance on the 972H — their shape brings some incompatibilities with the 966H machine. These buckets can be pinned on to the 966H, but will experience interference with machine linkage in the rack back position. For this reason, 972H Performance Series Buckets should **not** be used on 966H machines. This is different than current General Purpose Buckets.

#### Certain Bucket Sizes Require Additional Counterweight

Compared to a current bucket of the same rated capacity, Performance Series Buckets will move more material. To maintain appropriate machine stability, 980H machines utilizing the two larger Performance Series Buckets must be equipped with the aggregate loader counterweight. This is required for machine stability based on the bucket size/fill factor combination.

#### Compatible with G and G II machines

Performance Series Buckets for 988-size machines are compatible with standard and high lift linkages on G and G II Series machines.

**Material Handling Arm (MHA)**

The rated load for the MHA is 50% of the full turn static tipping load in each position or hydraulic or structural limitations. Manually extendable telescopic sections enable maximum lifting capacity at the full retracted position, and maximum lift height and reach in the fully extended position.

**Operating Load at Full Turn**

Model	Retracted	Mid	Extended
<b>IT14G</b>	1370 kg <b>3021 lb</b>	1076 kg <b>2373 lb</b>	888 kg <b>1958 lb</b>
<b>924H Standard Hook On</b>	1964 kg <b>4321 lb</b>	1560 kg <b>3432 lb</b>	1296 kg <b>2851 lb</b>
<b>924H High Lift Hook On</b>	1737 kg <b>3821 lb</b>	1405 kg <b>3091 lb</b>	1181 kg <b>2598 lb</b>
<b>930H Standard Hook On</b>	2333 kg <b>5133 lb</b>	1868 kg <b>4110 lb</b>	1559 kg <b>3430 lb</b>
<b>930H High Lift Hook On</b>	2072 kg <b>4558 lb</b>	1687 kg <b>3711 lb</b>	1425 kg <b>3135 lb</b>

Storm sewer pipes:  
1556 kg (3430 lb)

IT14G ... no  
924H ... yes in retracted  
930H ... yes in retracted and mid

Manhole boxes:  
1361 kg (3000 lb)

IT14G ... no  
924H ... yes in retracted and mid  
930H ... yes in retracted, mid and extended

**Buckets**

All general purpose buckets are interchangeable on 924H-930H due to common attachment points on the quick couplers. Bucket selection will depend on the material density in your application. Offering multiple sized buckets allows the user the flexibility to closely match material density and bucket size with machine capability. Equipping a machine with too large a bucket will result in unacceptable stability — too small a bucket may provide inadequate tire coverage.

**Bucket 1900 kg/m<sup>3</sup> (3200 lb/yd<sup>3</sup>) ... 100% fill factor**

Model	Bucket	Payload	50% Full Turn Static Tipping
<b>924H* Hook On</b>	1.8 m <sup>3</sup>	3420 kg	3638 kg
	<b>2.3 yd<sup>3</sup></b>	<b>7360 lb</b>	<b>8004 lb</b>
	2.1 m <sup>3</sup>	3990 kg	3549 kg
	<b>2.7 yd<sup>3</sup></b>	<b>8640 lb</b>	<b>7808 lb</b>
<b>930H* Hook On</b>	2.1 m <sup>3</sup>	3990 kg	3864 kg
	<b>2.7 yd<sup>3</sup></b>	<b>8640 lb</b>	<b>8501 lb</b>
	2.3 m <sup>3</sup>	4370 kg	3810 kg
	<b>3.0 yd<sup>3</sup></b>	<b>9600 lb</b>	<b>8382 lb</b>

**NOTE:** Metric numbers are a product of conversion.  
\*924H and 930H equipped with 20.5-R25 (L-3) tires.

**Machine/Attachment Recommendation**

**930H** — The greater static tipping load capabilities allow it to do a greater portion of the contractor’s total work processes. With the following attachments, the 930H could replace part or all of the specialty units, such as the wheel loader, rough terrain lift truck, street sweeper, and/or the trench compactor. 2.1 m<sup>3</sup> (2.75 yd<sup>3</sup>), 2.3 m<sup>3</sup> (3.0 yd<sup>3</sup>), or 2.5 m<sup>3</sup> (3.25 yd<sup>3</sup>) General Purpose Bucket  
1350 mm (53 in) forks (handles all pipes)  
Material Handling Arm — (handles pipe sizes under 1067 mm (42 in) concrete and manhole boxes ... 225 would have to set 1219 mm (48 in) and larger concrete pipe  
Broom

**Optional Attachments to Consider:**

- 24-LH compactor wheel
- Rebar snips
- Asphalt cutter

**906H  
Vertical Coupler**

Bucket Type	Rated Capacity		Maximum Material Density	
	m <sup>3</sup>	yd <sup>3</sup>	kg/m <sup>3</sup>	lb/yd <sup>3</sup>
General Purpose	0.90	<b>1.18</b>	1755	<b>2952</b>
Light Material	1.20	<b>1.57</b>	1208	<b>2032</b>
Multi-Purpose	0.75	<b>0.98</b>	2131	<b>3584</b>

**906H  
Horizontal Coupler**

Bucket Type	Rated Capacity		Maximum Material Density	
	m <sup>3</sup>	yd <sup>3</sup>	kg/m <sup>3</sup>	lb/yd <sup>3</sup>
General Purpose	0.90	<b>1.18</b>	1889	<b>3177</b>
Light Material	1.20	<b>1.57</b>	1271	<b>2138</b>
Multi-Purpose	0.75	<b>0.98</b>	2184	<b>3674</b>

**907H  
Vertical Coupler**

Bucket Type	Rated Capacity		Maximum Material Density	
	m <sup>3</sup>	yd <sup>3</sup>	kg/m <sup>3</sup>	lb/yd <sup>3</sup>
General Purpose	1.00	<b>1.31</b>	1584	<b>2664</b>
Light Material	1.20	<b>1.57</b>	1218	<b>2049</b>
Multi-Purpose	0.75	<b>0.98</b>	2149	<b>3615</b>

**907H  
Horizontal Coupler**

Bucket Type	Rated Capacity		Maximum Material Density	
	m <sup>3</sup>	yd <sup>3</sup>	kg/m <sup>3</sup>	lb/yd <sup>3</sup>
General Purpose	1.00	<b>1.31</b>	1706	<b>2870</b>
Light Material	1.20	<b>1.57</b>	1310	<b>2203</b>
Multi-Purpose	0.75	<b>0.98</b>	2202	<b>3704</b>

**908H  
Vertical Coupler**

Bucket Type	Rated Capacity		Maximum Material Density	
	m <sup>3</sup>	yd <sup>3</sup>	kg/m <sup>3</sup>	lb/yd <sup>3</sup>
General Purpose	1.10	<b>1.44</b>	1549	<b>2605</b>
Light Material	1.50	<b>1.96</b>	1034	<b>1739</b>
Multi-Purpose	0.90	<b>1.18</b>	1929	<b>3245</b>

**908H  
Horizontal Coupler**

Bucket Type	Rated Capacity		Maximum Material Density	
	m <sup>3</sup>	yd <sup>3</sup>	kg/m <sup>3</sup>	lb/yd <sup>3</sup>
General Purpose	1.10	<b>1.44</b>	1658	<b>2789</b>
Light Material	1.50	<b>1.96</b>	1106	<b>1860</b>
Multi-Purpose	0.90	<b>1.18</b>	1967	<b>3309</b>

**914G**

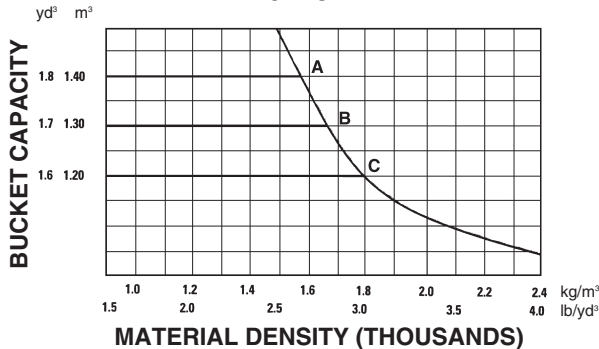

**KEY**

- A — 1.4 m<sup>3</sup> (**1.8 yd<sup>3</sup>**) General Purpose Bucket, bolt-on edge
- 1.4 m<sup>3</sup> (**1.8 yd<sup>3</sup>**) General Purpose Bucket, bolt-on teeth and segments
- B — 1.3 m<sup>3</sup> (**1.7 yd<sup>3</sup>**) General Purpose Bucket, bolt-on edge
- 1.3 m<sup>3</sup> (**1.7 yd<sup>3</sup>**) General Purpose Bucket, bolt-on teeth and segments
- 1.3 m<sup>3</sup> (**1.7 yd<sup>3</sup>**) General Bucket, bolt-on teeth
- 1.3 m<sup>3</sup> (**1.7 yd<sup>3</sup>**) General Purpose Bucket, flush mounted teeth
- C — 1.2 m<sup>3</sup> (**1.6 yd<sup>3</sup>**) General Purpose Bucket, bolt-on teeth

924Hz Pin On

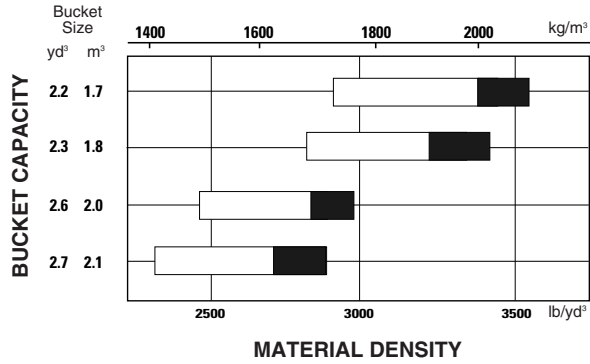

924H Hook On

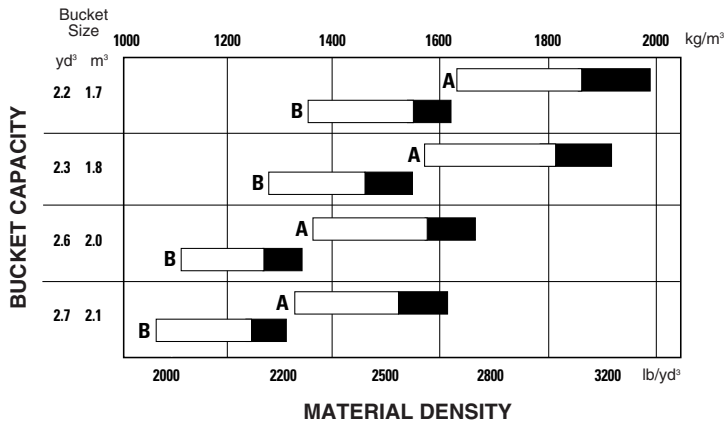

% = Bucket Fill Factor

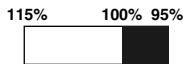

KEY  
A — Standard VersaLink  
B — High Lift

928Hz

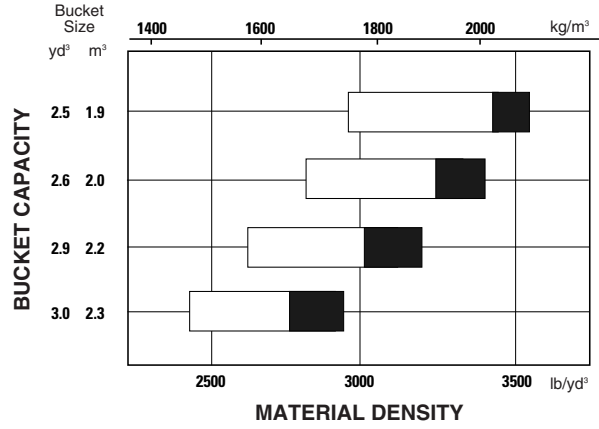

930H

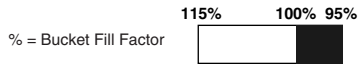
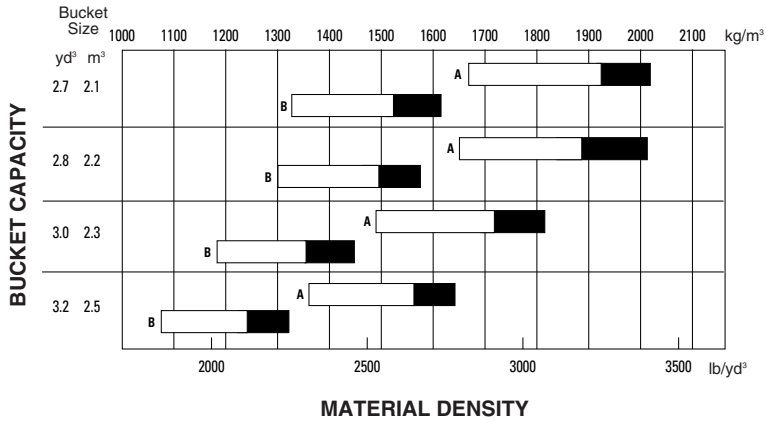

KEY  
A — Standard VersaLink  
B — High Lift

938H

Material Density		kg/m <sup>3</sup>	500	600	700	800	900	1000	1100	1200	1300	1400	1500	1600	1700	1800	1900	2000	2100	2200	2300	2400			
Standard Linkage	Pin-On	General Purpose	2.3 m <sup>3</sup> (3.0 yd <sup>3</sup> )																						
			2.5 m <sup>3</sup> (3.3 yd <sup>3</sup> )																						
			2.8 m <sup>3</sup> (3.7 yd <sup>3</sup> )																						
	3.0 m <sup>3</sup> (3.9 yd <sup>3</sup> )																								
	Material Handling*	2.8 m <sup>3</sup> (3.7 yd <sup>3</sup> )																							
		4.2 m <sup>3</sup> (5.5 yd <sup>3</sup> )																							
	Fusion QC	General Purpose	2.3 m <sup>3</sup> (3.0 yd <sup>3</sup> )																						
			2.5 m <sup>3</sup> (3.3 yd <sup>3</sup> )																						
			2.9 m <sup>3</sup> (3.8 yd <sup>3</sup> )																						
			3.1 m <sup>3</sup> (4.1 yd <sup>3</sup> )																						
		Material Handling*	3.1 m <sup>3</sup> (4.1 yd <sup>3</sup> )																						
			4.0 m <sup>3</sup> (5.2 yd <sup>3</sup> )																						
Woodchip/Mulch	5.5 m <sup>3</sup> (7.2 yd <sup>3</sup> )																								
	4.0 m <sup>3</sup> (5.2 yd <sup>3</sup> )																								
	Coal	4.6 m <sup>3</sup> (6.0 yd <sup>3</sup> )																							
		4.0 m <sup>3</sup> (5.2 yd <sup>3</sup> )																							
High Lift Linkage	Pin-On	General Purpose	2.3 m <sup>3</sup> (3.0 yd <sup>3</sup> )																						
			2.5 m <sup>3</sup> (3.3 yd <sup>3</sup> )																						
			2.8 m <sup>3</sup> (3.7 yd <sup>3</sup> )																						
	3.0 m <sup>3</sup> (3.9 yd <sup>3</sup> )																								
	Material Handling*	2.8 m <sup>3</sup> (3.7 yd <sup>3</sup> )																							
		4.2 m <sup>3</sup> (5.5 yd <sup>3</sup> )																							
	Fusion QC	General Purpose	2.3 m <sup>3</sup> (3.0 yd <sup>3</sup> )																						
			2.5 m <sup>3</sup> (3.3 yd <sup>3</sup> )																						
			2.9 m <sup>3</sup> (3.8 yd <sup>3</sup> )																						
			3.1 m <sup>3</sup> (4.1 yd <sup>3</sup> )																						
		Material Handling*	3.1 m <sup>3</sup> (4.1 yd <sup>3</sup> )																						
			4.0 m <sup>3</sup> (5.2 yd <sup>3</sup> )																						
Woodchip/Mulch	5.5 m <sup>3</sup> (7.2 yd <sup>3</sup> )																								
	4.0 m <sup>3</sup> (5.2 yd <sup>3</sup> )																								
	Coal	4.6 m <sup>3</sup> (6.0 yd <sup>3</sup> )																							
		4.0 m <sup>3</sup> (5.2 yd <sup>3</sup> )																							
Material Density		lb/yd <sup>3</sup>	843	1011	1180	1348	1517	1685	1854	2022	2191	2359	2528	2696	2865	3033	3202	3370	3539	3707	3876	4044			
Bucket Fill																									
115% 110% 105% 100% 95%																									

\*Material Handling buckets are flat floor buckets.

## 950H

Material Density		kg/m <sup>3</sup>	400	500	600	700	800	900	1000	1100	1200	1300	1400	1500	1600	1700	1800	1900	2000	2100	2200			
Standard Linkage	Pin-On	General Purpose	2.7 m <sup>3</sup> (3.5 yd <sup>3</sup> )																					
			2.9 m <sup>3</sup> (3.8 yd <sup>3</sup> )																					
			3.1 m <sup>3</sup> (4.1 yd <sup>3</sup> )																					
			3.3 m <sup>3</sup> (4.3 yd <sup>3</sup> )																					
			3.5 m <sup>3</sup> (4.6 yd <sup>3</sup> )																					
		4.0 (5.3)																						
	Fusion QC	General Purpose	3.1 m <sup>3</sup> (4.1 yd <sup>3</sup> )																					
			3.4 m <sup>3</sup> (4.5 yd <sup>3</sup> )																					
			3.6 (4.7)																					
			3.3 (4.4)																					
			3.1 (4.1)																					
		2.9 (3.8)																						
High Lift Linkage	Pin-On	General Purpose	2.7 m <sup>3</sup> (3.5 yd <sup>3</sup> )																					
			2.9 m <sup>3</sup> (3.8 yd <sup>3</sup> )																					
			3.1 m <sup>3</sup> (4.1 yd <sup>3</sup> )																					
			3.3 m <sup>3</sup> (4.3 yd <sup>3</sup> )																					
			3.5 m <sup>3</sup> (4.6 yd <sup>3</sup> )																					
		4.0 (5.3)																						
	Fusion QC	General Purpose	3.1 m <sup>3</sup> (4.1 yd <sup>3</sup> )																					
			3.4 m <sup>3</sup> (4.5 yd <sup>3</sup> )																					
			3.6 (4.7)																					
			3.4 (4.5)																					
			3.1 (4.1)																					
		2.9 (3.8)																						
Material Density		lb/yd <sup>3</sup>	674	843	1011	1180	1348	1517	1685	1854	2022	2191	2359	2528	2696	2865	3033	3202	3370	3539	3707			
Bucket Fill																								

\*Material Handling buckets are flat floor buckets.

962H

Material Density		kg/m <sup>3</sup>	400	500	600	700	800	900	1000	1100	1200	1300	1400	1500	1600	1700	1800	1900	2000	2100	2200			
Standard Linkage	Pin-On	General Purpose	2.9 m <sup>3</sup> (3.8 yd <sup>3</sup> )																					
			3.1 m <sup>3</sup> (4.1 yd <sup>3</sup> )																					
			3.3 m <sup>3</sup> (4.3 yd <sup>3</sup> )																					
			3.5 m <sup>3</sup> (4.6 yd <sup>3</sup> )																					
			3.6 m <sup>3</sup> (4.7 yd <sup>3</sup> )																					
		3.8 m <sup>3</sup> (5.0 yd <sup>3</sup> )																						
	Material Handling*	3.3 m <sup>3</sup> (4.3 yd <sup>3</sup> )																						
		3.5 m <sup>3</sup> (4.6 yd <sup>3</sup> )																						
		3.8 m <sup>3</sup> (5.0 yd <sup>3</sup> )																						
	Rock	3.1 m <sup>3</sup> (4.1 yd <sup>3</sup> )																						
		3.1 m <sup>3</sup> (4.1 yd <sup>3</sup> )																						
	Waste	5.2 m <sup>3</sup> (6.8 yd <sup>3</sup> )																						
6.0 (7.8)																								
Fusion QC	General Purpose	3.1 m <sup>3</sup> (4.1 yd <sup>3</sup> )																						
		3.4 m <sup>3</sup> (4.5 yd <sup>3</sup> )																						
		3.8 m <sup>3</sup> (5.0 yd <sup>3</sup> )																						
	Material Handling*	3.4 m <sup>3</sup> (4.5 yd <sup>3</sup> )																						
		3.8 m <sup>3</sup> (5.0 yd <sup>3</sup> )																						
		4.4 (5.7)																						
High Lift Linkage	Pin-On	General Purpose	2.9 m <sup>3</sup> (3.8 yd <sup>3</sup> )																					
			3.1 m <sup>3</sup> (4.1 yd <sup>3</sup> )																					
			3.3 m <sup>3</sup> (4.3 yd <sup>3</sup> )																					
			3.5 m <sup>3</sup> (4.6 yd <sup>3</sup> )																					
			3.6 m <sup>3</sup> (4.7 yd <sup>3</sup> )																					
		3.8 m <sup>3</sup> (5.0 yd <sup>3</sup> )																						
	Material Handling*	3.3 m <sup>3</sup> (4.3 yd <sup>3</sup> )																						
		3.5 m <sup>3</sup> (4.6 yd <sup>3</sup> )																						
		3.8 m <sup>3</sup> (5.0 yd <sup>3</sup> )																						
	Rock	3.1 m <sup>3</sup> (4.1 yd <sup>3</sup> )																						
		3.1 m <sup>3</sup> (4.1 yd <sup>3</sup> )																						
	Waste	5.2 m <sup>3</sup> (6.8 yd <sup>3</sup> )																						
6.0 (7.8)																								
Fusion QC	General Purpose	3.1 m <sup>3</sup> (4.1 yd <sup>3</sup> )																						
		3.4 m <sup>3</sup> (4.5 yd <sup>3</sup> )																						
		3.8 m <sup>3</sup> (5.0 yd <sup>3</sup> )																						
	Material Handling*	3.4 m <sup>3</sup> (4.5 yd <sup>3</sup> )																						
		3.8 m <sup>3</sup> (5.0 yd <sup>3</sup> )																						
		4.4 (5.7)																						
Material Density		lb/yd <sup>3</sup>	674	843	1011	1180	1348	1517	1685	1854	2022	2191	2359	2528	2696	2865	3033	3202	3370	3539	3707			
Bucket Fill																								
115% 110% 105% 100% 95%																								

\*Material Handling buckets are flat floor buckets.



### 966H

Material Density		kg/m <sup>3</sup>	600	700	800	900	1000	1100	1200	1300	1400	1500	1600	1700	1800	1900	2000	2100	2200	2300	2400			
Standard Linkage	Pin-On	General Purpose	3.6 m <sup>3</sup> (4.7 yd <sup>3</sup> )												4.1 (5.4)						3.6 (4.7)			
			3.8 m <sup>3</sup> (5.0 yd <sup>3</sup> )													4.4 (5.7)							3.8 (5.0)	
			4.0 m <sup>3</sup> (5.2 yd <sup>3</sup> )													4.6 (6.0)								4.0 (5.2)
			4.3 m <sup>3</sup> (5.6 yd <sup>3</sup> )												4.9 (6.5)									4.3 (5.6)
		Material Handling*	3.8 m <sup>3</sup> (5.0 yd <sup>3</sup> )													4.4 (5.7)							3.8 (5.0)	
		4.0 m <sup>3</sup> (5.2 yd <sup>3</sup> )													4.6 (6.0)								4.0 (5.2)	
	Rock	3.5 m <sup>3</sup> (4.6 yd <sup>3</sup> )																				3.5 (4.6)	3.3 (4.4)	
		3.5 m <sup>3</sup> (4.6 yd <sup>3</sup> )																				3.5 (4.6)	3.3 (4.4)	
	HD Rock	3.5 m <sup>3</sup> (4.6 yd <sup>3</sup> )																				3.5 (4.6)	3.3 (4.4)	
	Waste	6.4 m <sup>3</sup> (8.4 yd <sup>3</sup> )						7.4 (9.5)															6.4 (8.4)	
Fusion QC	General Purpose	3.8 m <sup>3</sup> (5.0 yd <sup>3</sup> )																				3.8 (5.0)		
		4.2 m <sup>3</sup> (5.5 yd <sup>3</sup> )												4.8 (6.3)									4.2 (5.5)	
	Material Handling*	4.2 m <sup>3</sup> (5.5 yd <sup>3</sup> )												4.8 (6.3)								4.2 (5.5)		
	Waste	6.5 m <sup>3</sup> (8.5 yd <sup>3</sup> )						7.5 (9.8)															6.5 (8.5)	
	Woodchip/Mulch	9.9 m <sup>3</sup> (12.9 yd <sup>3</sup> )	11.4 (14.9)					9.9 (12.9)																
Coal	6.7 m <sup>3</sup> (8.8 yd <sup>3</sup> )							7.7 (10.1)														6.7 (8.8)		
	7.7 m <sup>3</sup> (10.1 yd <sup>3</sup> )							8.9 (11.6)														7.7 (10.1)		
High Lift Linkage	Pin-On	General Purpose	3.6 m <sup>3</sup> (4.7 yd <sup>3</sup> )																			3.6 (4.7)		
			3.8 m <sup>3</sup> (5.0 yd <sup>3</sup> )														4.4 (5.7)						3.8 (5.0)	
			4.0 m <sup>3</sup> (5.2 yd <sup>3</sup> )														4.6 (6.0)							4.0 (5.2)
			4.3 m <sup>3</sup> (5.6 yd <sup>3</sup> )												4.9 (6.5)									4.3 (5.6)
		Material Handling*	3.8 m <sup>3</sup> (5.0 yd <sup>3</sup> )													4.4 (5.7)							3.8 (5.0)	
		4.0 m <sup>3</sup> (5.2 yd <sup>3</sup> )													4.6 (6.0)								4.0 (5.2)	
	Rock	3.5 m <sup>3</sup> (4.6 yd <sup>3</sup> )																				3.5 (4.6)	3.3 (4.4)	
		3.5 m <sup>3</sup> (4.6 yd <sup>3</sup> )																				3.5 (4.6)	3.3 (4.4)	
	HD Rock	3.5 m <sup>3</sup> (4.6 yd <sup>3</sup> )																				3.5 (4.6)	3.3 (4.4)	
	Waste	6.4 m <sup>3</sup> (8.4 yd <sup>3</sup> )						7.4 (9.5)															6.4 (8.4)	
Fusion QC	General Purpose	3.8 m <sup>3</sup> (5.0 yd <sup>3</sup> )																				3.8 (5.0)		
		4.2 m <sup>3</sup> (5.5 yd <sup>3</sup> )												4.8 (6.3)									4.2 (5.5)	
	Material Handling*	4.2 m <sup>3</sup> (5.5 yd <sup>3</sup> )												4.8 (6.3)								4.2 (5.5)		
	Waste	6.5 m <sup>3</sup> (8.5 yd <sup>3</sup> )						7.5 (9.8)															6.5 (8.5)	
	Woodchip/Mulch	9.9 m <sup>3</sup> (12.9 yd <sup>3</sup> )	11.4 (14.9)					9.9 (12.9)																
Coal	6.7 m <sup>3</sup> (8.8 yd <sup>3</sup> )							7.7 (10.1)														6.7 (8.8)		
	7.7 m <sup>3</sup> (10.1 yd <sup>3</sup> )							8.9 (11.6)														7.7 (10.1)		
Material Density		lb/yd <sup>3</sup>	1011	1180	1348	1517	1685	1854	2022	2191	2359	2528	2696	2865	3033	3202	3370	3539	3707	3876	4044			
Bucket Fill																								
115% 110% 105% 100% 95%																								

\*Material Handling buckets are flat floor buckets.

972H

Material Density		kg/m³	600	700	800	900	1000	1100	1200	1300	1400	1500	1600	1700	1800	1900	2000	2100	2200	2300	2400			
Standard Linkage	Pin-On	Performance Series — General Purpose	4.3 m³ (5.6 yd³) 4.8 m³ (6.25 yd³)									5.5 (7.2)		4.9 (6.5)		4.3 (5.6)								
		General Purpose	4.0 m³ (5.2 yd³)												4.9 (6.5)		4.6 (6.0)		4.0 (5.2)					
			4.3 m³ (5.6 yd³)													5.2 (6.8)		4.5 (5.9)		4.3 (5.6)				
			4.5 m³ (5.9 yd³)													5.3 (6.9)		4.6 (6.0)						
			4.6 m³ (6.0 yd³)													5.9 (7.7)		5.1 (6.7)						
	Material Handling*	4.3 m³ (5.6 yd³) 4.7 m³ (6.2 yd³)												5.4 (7.1)		4.9 (6.5)		4.3 (5.6)						
	Rock	4.0 m³ (5.2 yd³)																4.0 (5.2)		3.8 (4.9)				
	HD Rock	4.0 m³ (5.2 yd³)																4.0 (5.2)		3.8 (4.9)				
	Waste	6.4 m³ (8.4 yd³)						7.4 (9.6)				6.4 (8.4)												
	Fusion QC	General Purpose	4.2 m³ (5.5 yd³) 4.8 m³ (6.3 yd³)													5.5 (7.2)		4.8 (6.3)		4.2 (5.5)				
		Material Handling*	4.6 m³ (6.0 yd³)													5.3 (6.9)		4.6 (6.0)						
		Waste	6.5 m³ (8.5 yd³)							7.5 (9.8)			6.5 (8.5)											
		Woodchip/Mulch	9.9 m³ (12.9 yd³)	11.4 (14.9)				9.9 (12.9)																
		Coal	6.7 m³ (8.8 yd³) 7.7 m³ (10.1 yd³)							7.7 (10.1)			6.7 (8.8)											
High Lift Linkage	Pin-On	Performance Series — General Purpose	4.3 m³ (5.6 yd³) 4.8 m³ (6.25 yd³)												5.5 (7.2)		4.9 (6.5)		4.3 (5.6)					
		General Purpose	4.0 m³ (5.2 yd³)													4.9 (6.5)		4.6 (6.0)		4.0 (5.2)				
			4.3 m³ (5.6 yd³)													5.2 (6.8)		4.5 (5.9)		4.3 (5.6)				
			4.5 m³ (5.9 yd³)													5.3 (6.9)		4.6 (6.0)						
			4.6 m³ (6.0 yd³)													5.9 (7.7)		5.1 (6.7)						
	Material Handling*	4.3 m³ (5.6 yd³) 4.7 m³ (6.2 yd³)													5.4 (7.1)		4.9 (6.5)		4.3 (5.6)					
	Rock	4.0 m³ (5.2 yd³)																4.0 (5.2)		3.8 (4.9)				
	HD Rock	4.0 m³ (5.2 yd³)																4.0 (5.2)		3.8 (4.9)				
	Waste	6.4 m³ (8.4 yd³)						7.4 (9.6)			6.4 (8.4)													
	Fusion QC	General Purpose	4.2 m³ (5.5 yd³) 4.8 m³ (6.3 yd³)													5.5 (7.2)		4.8 (6.3)		4.2 (5.5)				
		Material Handling*	4.6 m³ (6.0 yd³)													5.3 (6.9)		4.6 (6.0)						
		Waste	6.5 m³ (8.5 yd³)							7.5 (9.8)			6.5 (8.5)											
		Woodchip/Mulch	9.9 m³ (12.9 yd³)	11.4 (14.9)				9.9 (12.9)																
		Coal	6.7 m³ (8.8 yd³) 7.7 m³ (10.1 yd³)							7.7 (10.1)			6.7 (8.8)											
Material Density		lb/yd³	1011	1180	1348	1517	1685	1854	2022	2191	2359	2528	2696	2865	3033	3202	3370	3539	3707	3876	4044			
Bucket Fill		115% 110% 105% 100% 95%																						

\*Material Handling buckets are flat floor buckets.

**980H**

Material Density		kg/m <sup>3</sup>	700	800	900	1000	1100	1200	1300	1400	1500	1600	1700	1800	1900	2000	2100	2200	2300	2400	2500	2600		
Standard Linkage	Pin-On	Performance Series — General Purpose	5.3 m <sup>3</sup> (7.0 yd <sup>3</sup> )									6.1 (8.0)			5.3 (7.0)									
			5.7 m <sup>3</sup> (7.5 yd <sup>3</sup> )**									6.6 (8.6)			5.7 (7.5)									
			6.0 m <sup>3</sup> (7.85 yd <sup>3</sup> )**									6.9 (9.0)			6.0 (7.85)									
	Pin-On	General Purpose	4.6 m <sup>3</sup> (6.0 yd <sup>3</sup> )														5.3 (6.9)					4.6 (6.0)		
			5.0 m <sup>3</sup> (6.5 yd <sup>3</sup> )														5.8 (7.5)				5.0 (6.5)			
			5.4 m <sup>3</sup> (7.1 yd <sup>3</sup> )											6.2 (8.1)			5.4 (7.1)							
			5.7 m <sup>3</sup> (7.5 yd <sup>3</sup> )									6.6 (8.6)				5.7 (7.5)								
			6.1 m <sup>3</sup> (8.0 yd <sup>3</sup> )**									7.0 (9.2)				6.1 (8.0)								
		HD General Purpose	5.4 m <sup>3</sup> (7.1 yd <sup>3</sup> )											6.2 (8.1)			5.4 (7.1)							
		Material Handling*	6.1 m <sup>3</sup> (8.0 yd <sup>3</sup> )**									7.0 (9.2)				6.1 (8.0)								
		Rock	4.2 m <sup>3</sup> (5.5 yd <sup>3</sup> )																		4.5 (5.9)		4.2 (5.5)	4.0 (5.2)
			4.5 m <sup>3</sup> (5.9 yd <sup>3</sup> )																			4.3 (5.6)		
Spade Rock	4.3 m <sup>3</sup> (5.6 yd <sup>3</sup> )																				4.3 (5.6)	4.1 (5.3)		
	4.7 m <sup>3</sup> (6.2 yd <sup>3</sup> )																							
HD Quarry Spade Rock	4.5 m <sup>3</sup> (5.9 yd <sup>3</sup> )																4.7 (6.2)		4.5 (5.9)					
Waste	10.5 m <sup>3</sup> (13.7 yd <sup>3</sup> )	12.1 (15.8)				10.5 (13.7)																		
Coal	8.2 m <sup>3</sup> (10.7 yd <sup>3</sup> )			9.4 (12.3)					8.2 (10.7)															
High Lift Linkage	Pin-On	Performance Series — General Purpose	5.3 m <sup>3</sup> (7.0 yd <sup>3</sup> )										6.1 (8.0)		5.3 (7.0)									
			5.7 m <sup>3</sup> (7.5 yd <sup>3</sup> )**										6.6 (8.6)		5.7 (7.5)									
			6.0 m <sup>3</sup> (7.85 yd <sup>3</sup> )**										6.9 (9.0)		6.0 (7.85)									
	Pin-On	General Purpose	4.6 m <sup>3</sup> (6.0 yd <sup>3</sup> )															5.3 (6.9)				4.6 (6.0)		
			5.0 m <sup>3</sup> (6.5 yd <sup>3</sup> )															5.8 (7.5)				5.0 (6.5)		
			5.4 m <sup>3</sup> (7.1 yd <sup>3</sup> )											6.2 (8.1)		5.4 (7.1)								
			5.7 m <sup>3</sup> (7.5 yd <sup>3</sup> )										6.6 (8.6)			5.7 (7.5)								
		HD General Purpose	5.4 m <sup>3</sup> (7.1 yd <sup>3</sup> )											6.2 (8.1)		5.4 (7.1)								
		Rock	4.2 m <sup>3</sup> (5.5 yd <sup>3</sup> )																		4.5 (5.9)		4.2 (5.6)	4.0 (5.2)
			4.5 m <sup>3</sup> (5.9 yd <sup>3</sup> )																			4.3 (5.6)		
		Spade Rock	4.3 m <sup>3</sup> (5.6 yd <sup>3</sup> )																				4.3 (4.3)	4.1 (5.3)
			4.7 m <sup>3</sup> (6.2 yd <sup>3</sup> )																4.7 (6.2)		4.5 (5.9)			
HD Quarry Spade Rock	4.5 m <sup>3</sup> (5.9 yd <sup>3</sup> )																4.5 (5.9)		4.3 (5.6)					
Waste	10.5 m <sup>3</sup> (13.7 yd <sup>3</sup> )	12.1 (15.8)				10.5 (13.7)																		
Coal	8.2 m <sup>3</sup> (10.7 yd <sup>3</sup> )			9.4 (12.3)					8.2 (10.7)															
Material Density		lb/yd <sup>3</sup>	1180	1348	1517	1685	1854	2022	2191	2359	2528	2696	2865	3033	3202	3370	3539	3707	3876	4044	4213	4381		
Bucket Fill																								
115% 110% 105% 100% 95%																								

\*Material Handling buckets are flat floor buckets.  
\*\*With 980H Aggregate Loader Package.

**988H BXY4000-UP**

Material Density				Bucket Volume	
kg/m <sup>3</sup>	tonnes/m <sup>3</sup>	lb/yd <sup>3</sup>	tons/yd <sup>3</sup>	m <sup>3</sup>	yd <sup>3</sup>
1483-1614	1.47-1.61	2500-2750	1.25-1.38	7.7	10
1638-1801	1.64-1.80	2700-3000	1.39-1.53	6.9	9
1766-1942	1.77-1.94	3000-3300	1.50-1.65	6.4	8.33

**990H — Standard**

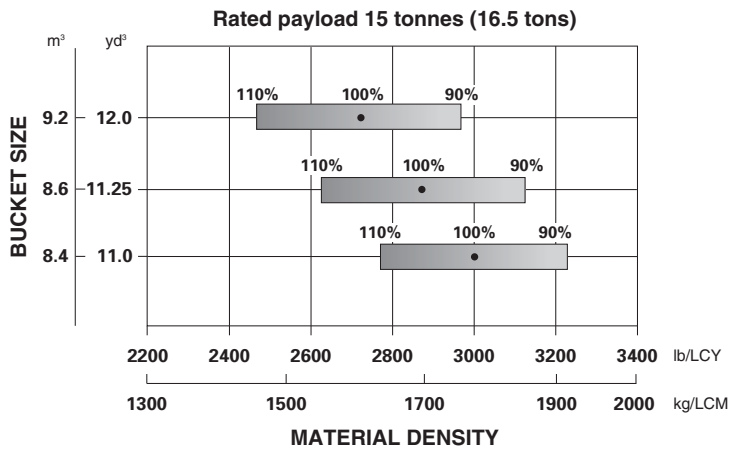

NOTE: Percentages shown represent bucket fill factor.

• – Center point at 100% fill

**992K — Standard**

*Up to specified density for 100% fill factor*

Bucket Volume		Material Density	
m <sup>3</sup>	yd <sup>3</sup>	kg/m <sup>3</sup>	lb/yd <sup>3</sup>
12.2	16	1780	3000
11.5	15	1890	3200
10.7	14	2030	3430

**992K — High Lift**

*Up to specified density for 100% fill factor*

Bucket Volume		Material Density	
m <sup>3</sup>	yd <sup>3</sup>	kg/m <sup>3</sup>	lb/yd <sup>3</sup>
12.2	16	1560	2630
11.5	15	1560	2630
10.7	14	1560	2630

**993K — Standard**

*Up to specified density for 100% fill factor*

Bucket Volume		Material Density	
m <sup>3</sup>	yd <sup>3</sup>	kg/m <sup>3</sup>	lb/yd <sup>3</sup>
15.3	20	1780	3000
14.5	19	1870	3160
13.8	18	1970	3330

**993K — High Lift**

*Up to specified density for 100% fill factor*

Bucket Volume		Material Density	
m <sup>3</sup>	yd <sup>3</sup>	kg/m <sup>3</sup>	lb/yd <sup>3</sup>
14.5	19	1720	2890
13.8	18	1810	3060
13.0	17	1920	3240

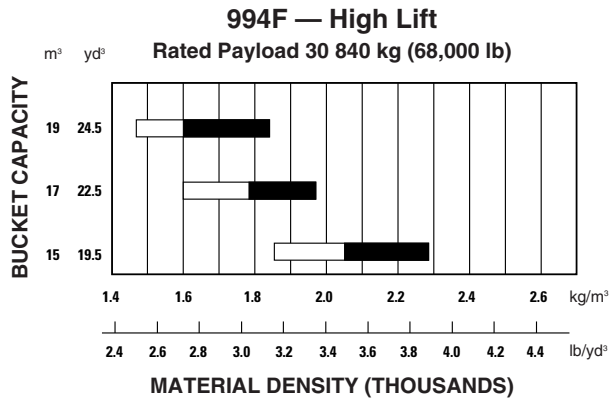
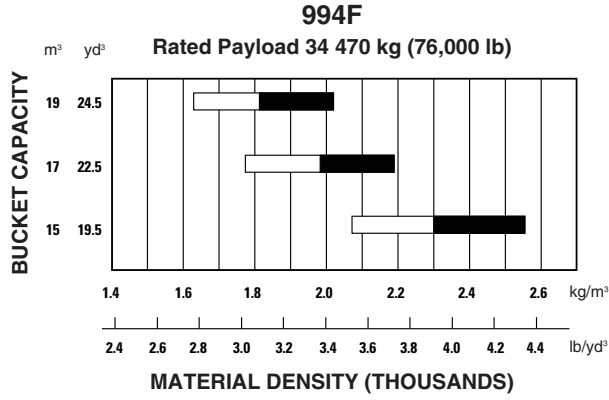

% = Bucket Fill Factor      110%    100%    95%    Standard

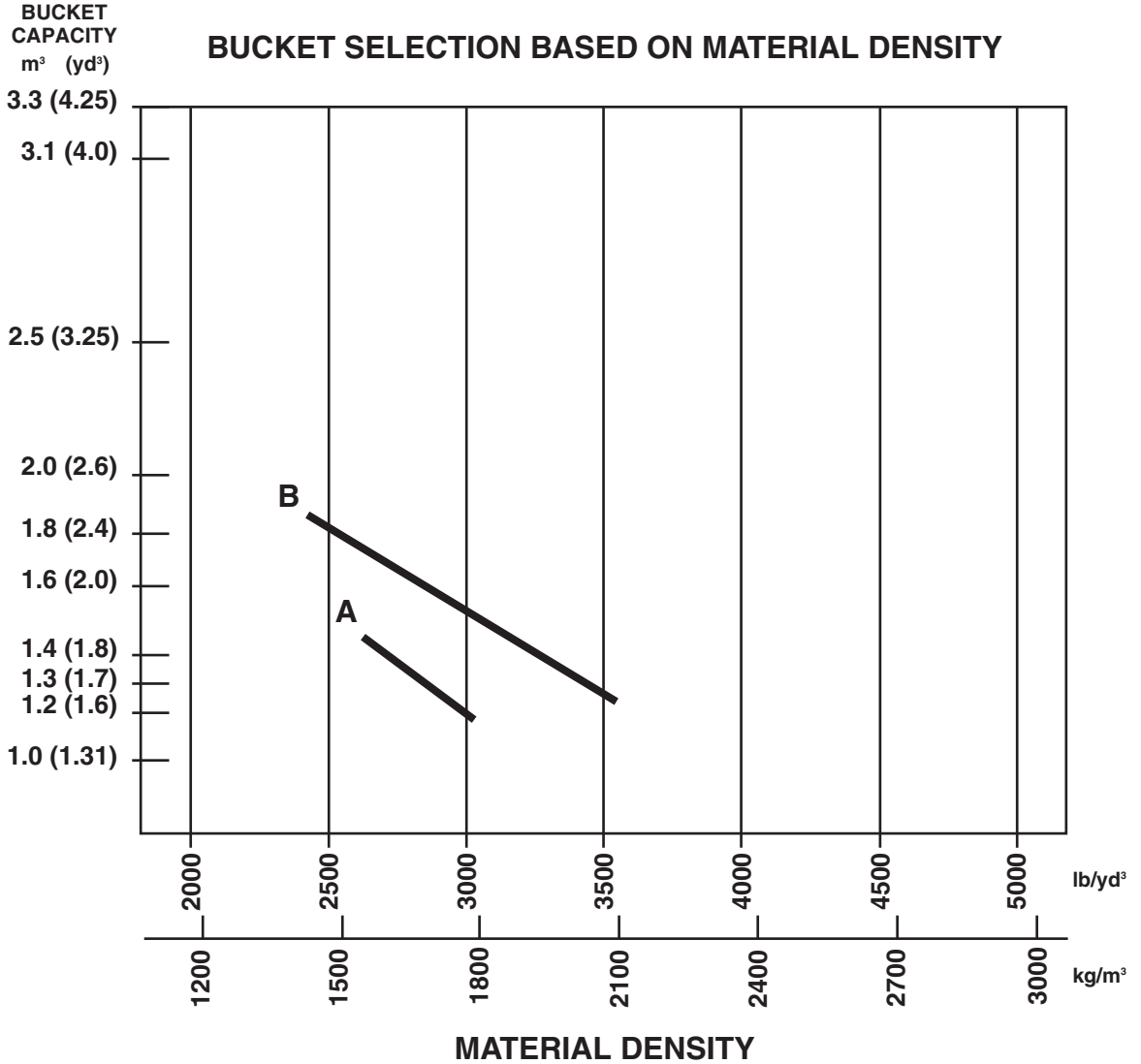

NOTE: Machines equipped same as those on Performance Data pages.

**KEY**  
 A — IT14G  
 B — 924Hz

### IT38H

Material Density		kg/m <sup>3</sup>	1200	1300	1400	1500	1600	1700	1800	
Standard Linkage Fusion QC	General Purpose	2.5 m <sup>3</sup> (3.3 yd <sup>3</sup> ) 3.1 m <sup>3</sup> (4.1 yd <sup>3</sup> )	3.6 (4.7)			3.1 (4.1)		2.9 (3.8)		
	Material Handling*	2.5 m <sup>3</sup> (3.3 yd <sup>3</sup> ) 2.7 m <sup>3</sup> (3.5 yd <sup>3</sup> ) 2.9 m <sup>3</sup> (3.8 yd <sup>3</sup> ) 3.1 m <sup>3</sup> (4.1 yd <sup>3</sup> )	3.6 (4.7)			3.3 (4.3)		3.1 (4.1)		2.9 (3.8)
Material Density		lb/yd <sup>3</sup>	2022	2191	2359	2528	2696	2865	3033	
Bucket Fill		115% 110% 105% 100% 95%								

\*Material Handling buckets are flat floor buckets.

### IT62H

Material Density		kg/m <sup>3</sup>	1200	1300	1400	1500	1600	1700	1800	
Standard Linkage Fusion QC	General Purpose	3.1 m <sup>3</sup> (4.1 yd <sup>3</sup> ) 3.4 m <sup>3</sup> (4.5 yd <sup>3</sup> ) 3.8 m <sup>3</sup> (5.0 yd <sup>3</sup> )	4.4 (5.7)		3.9 (5.1)		3.6 (4.7)		3.1 (4.1)	
	Material Handling*	3.5 m <sup>3</sup> (4.6 yd <sup>3</sup> ) 3.8 m <sup>3</sup> (5.0 yd <sup>3</sup> )	4.4 (5.7)		4.0 (5.2)		3.8 (5.0)			3.5 (4.6)
Material Density		lb/yd <sup>3</sup>	2022	2191	2359	2528	2696	2865	3033	
Bucket Fill		115% 110% 105% 100% 95%								

\*Material Handling buckets are flat floor buckets.



- 928Hz
- 20.5-25 Tires

**928Hz**

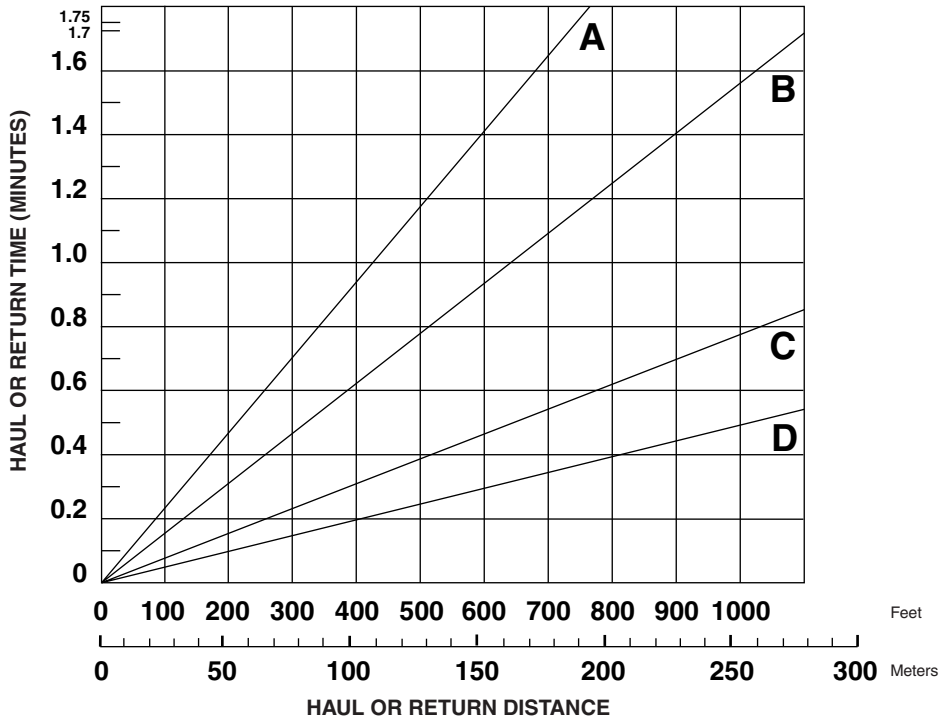

**KEY**

- A — 1st Forward and Reverse Speed
- B — 2nd Forward and Reverse Speed
- C — 3rd Forward and Reverse Speed
- D — 4th Forward Speed

**NOTE:** Loader maneuver, load and dump time must be added to travel time. 4th gear curve not indicated; primarily used for transporting machine.

Travel Time — Loaded  
 ● 938H  
 ● 20.5R-25 Tires

**Wheel Loaders  
 Integrated Toolcarriers**

**938H TRAVEL TIME — LOADED**

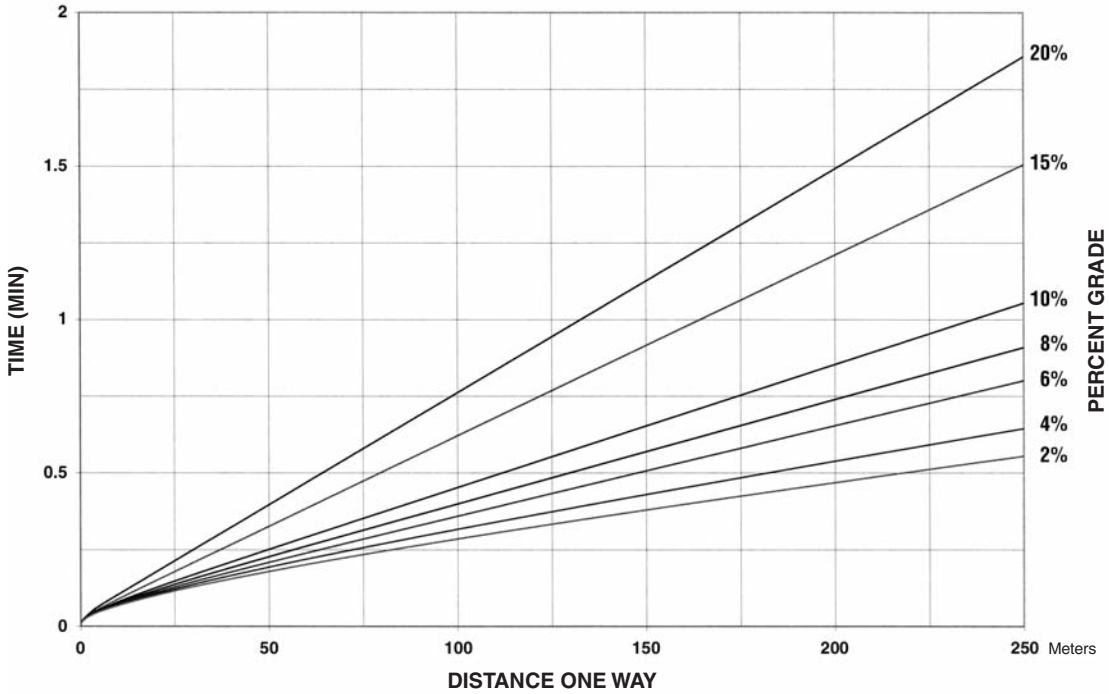

Travel times assume maximum governor pedal depression and automatic shifting for any VSC setting.

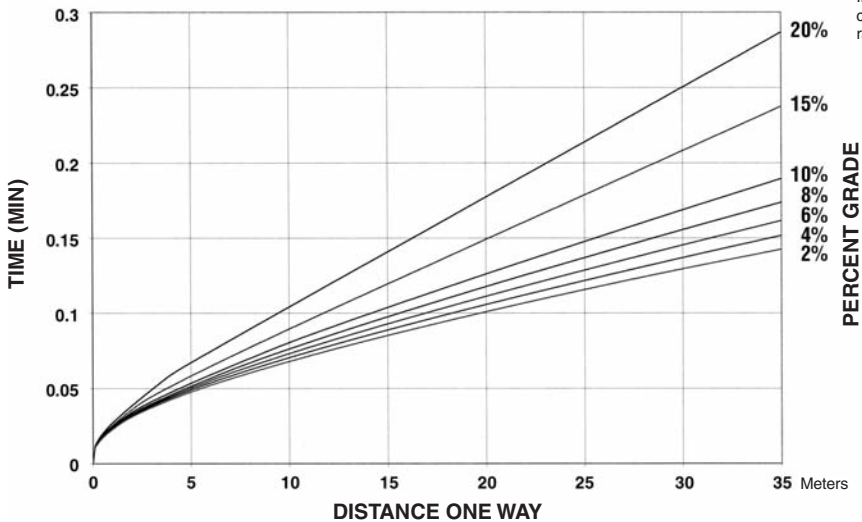

In load and carry applications it is important to consult the tire manufacturer on Ton-MPH ratings and pressure recommendations.

- 938H
- 20.5R-25 Tires

**938H TRAVEL TIME — EMPTY**

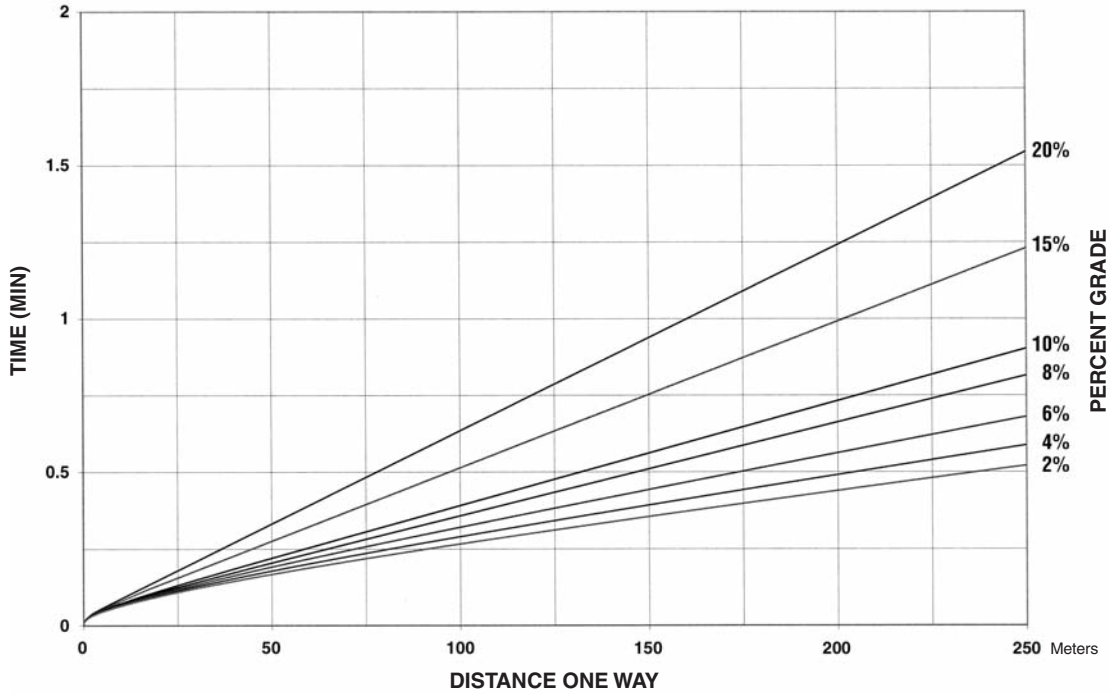

Travel times assume maximum governor pedal depression and automatic shifting for any VSC setting.

In load and carry applications it is important to consult the tire manufacturer on Ton-MPH ratings and pressure recommendations.

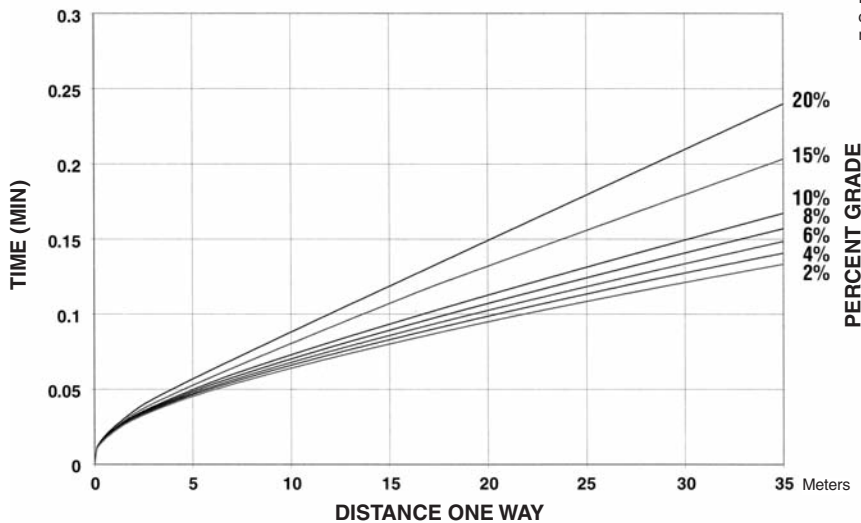

Travel Time — Loaded  
 ● 950H  
 ● 23.50-R25 Tires

**Wheel Loaders  
 Integrated Toolcarriers**

**950H TRAVEL TIME — LOADED**

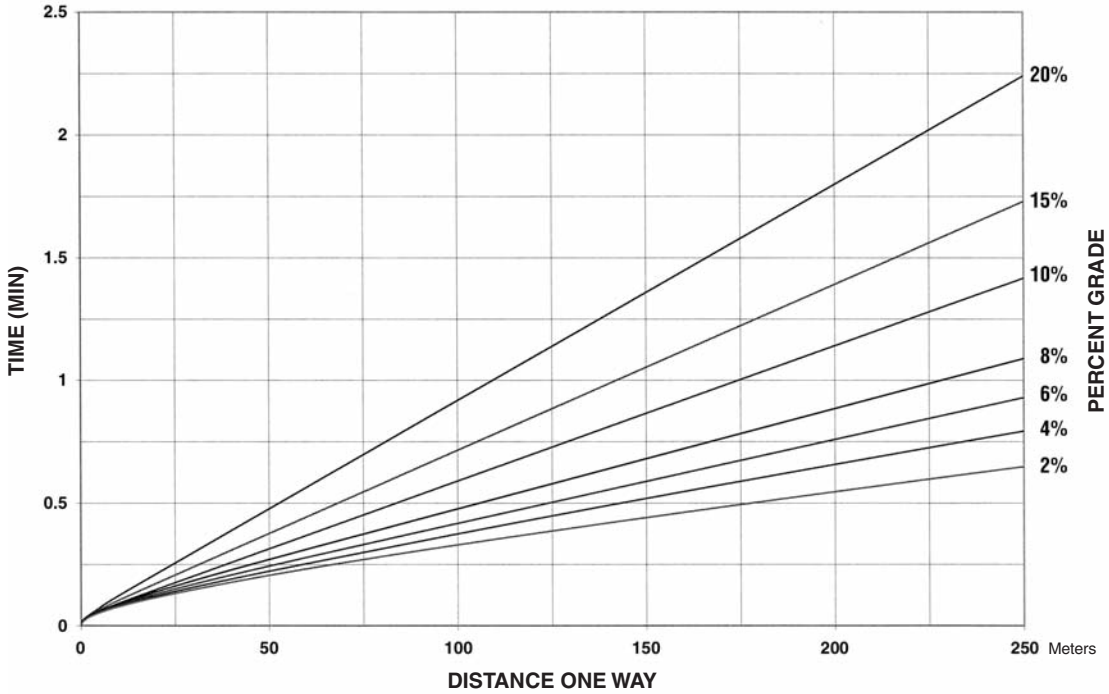

Travel times assume maximum governor pedal depression and automatic shifting for any VSC setting.

In load and carry applications it is important to consult the tire manufacturer on Ton-MPH ratings and pressure recommendations.

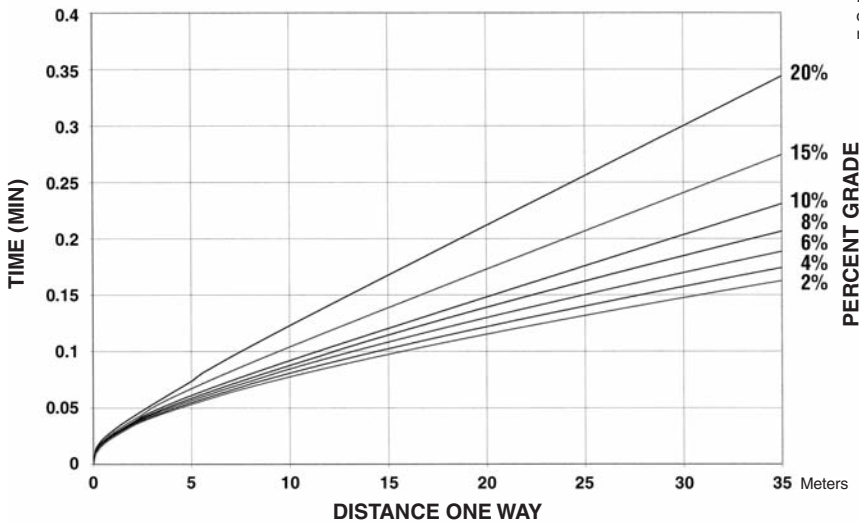

**950H TRAVEL TIME — EMPTY**

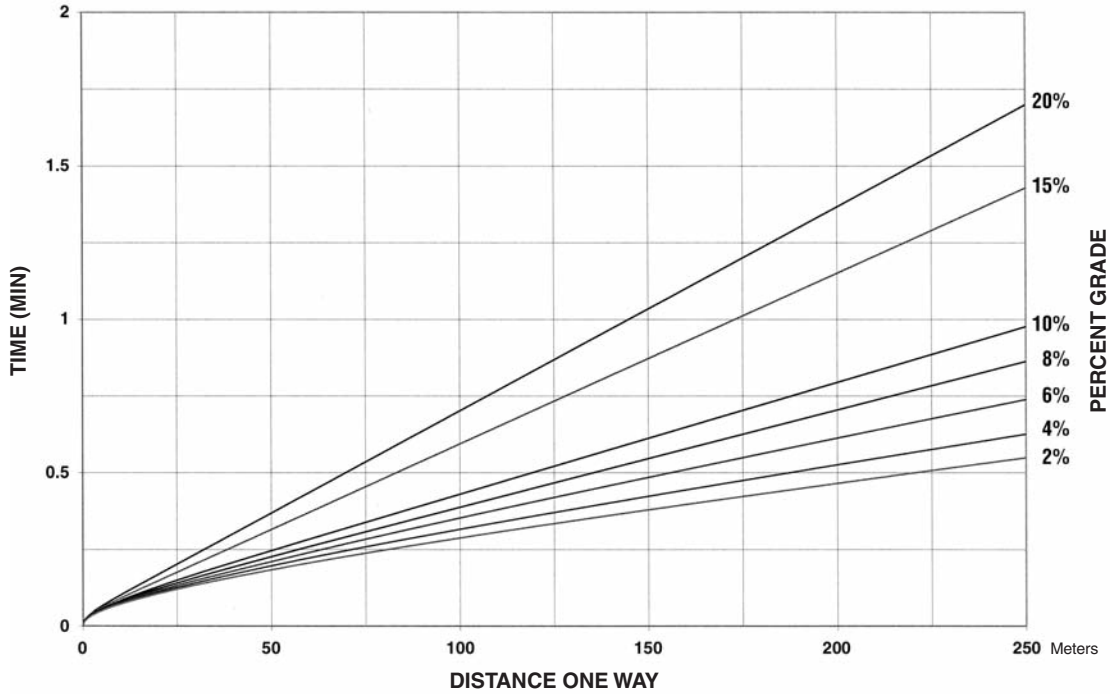

Travel times assume maximum governor pedal depression and automatic shifting for any VSC setting.

In load and carry applications it is important to consult the tire manufacturer on Ton-MPH ratings and pressure recommendations.

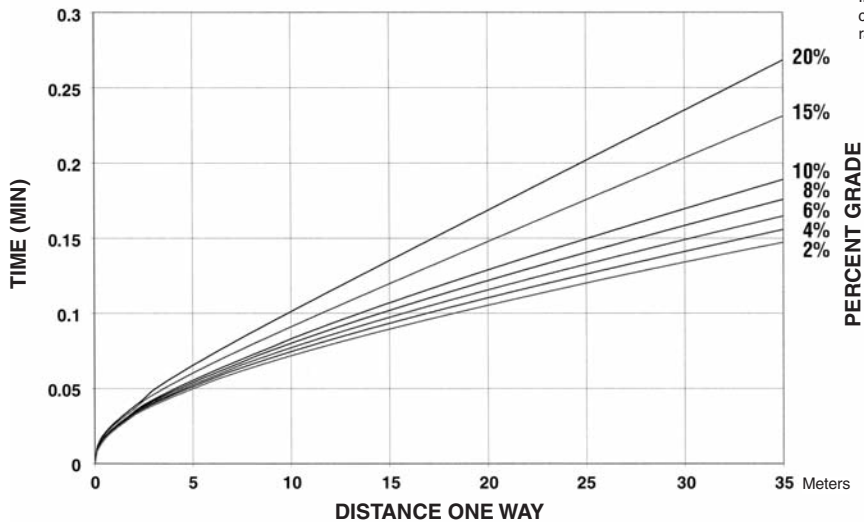

Travel Time — Loaded  
 ● 962H  
 ● 23.5-R25 Tires

**Wheel Loaders  
 Integrated Toolcarriers**

**962H TRAVEL TIME — LOADED**

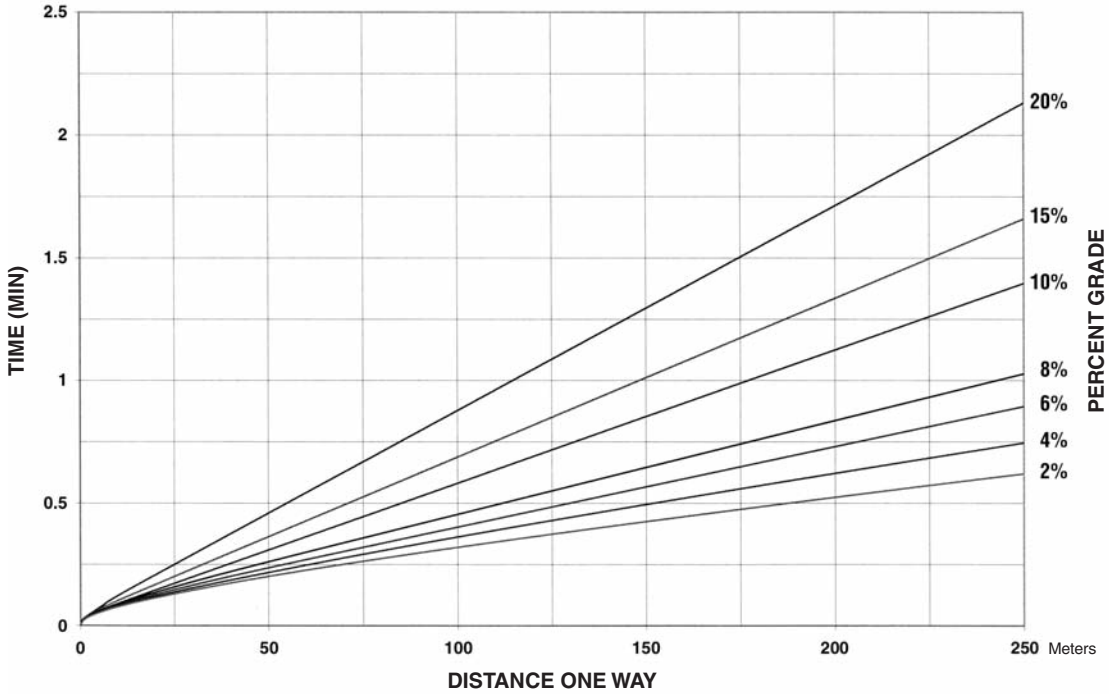

Travel times assume maximum governor pedal depression and automatic shifting for any VSC setting.

In load and carry applications it is important to consult the tire manufacturer on Ton-MPH ratings and pressure recommendations.

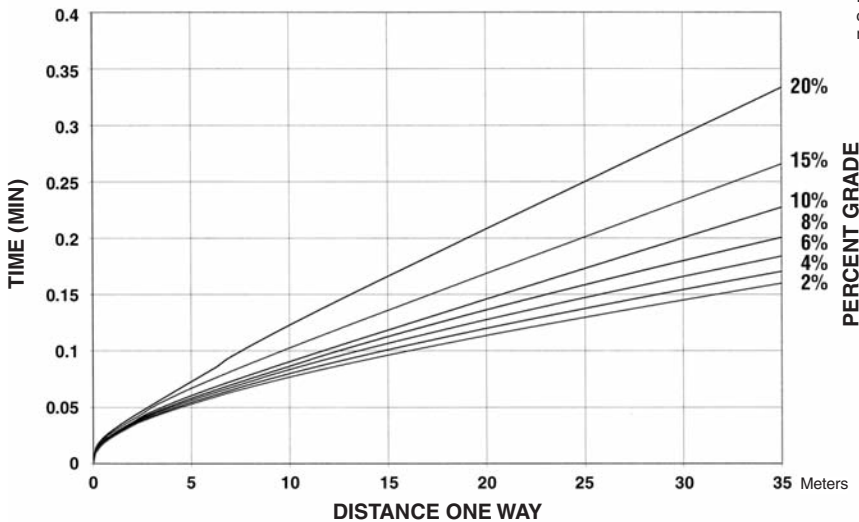

- 962H
- 23.5-R25 Tires

**962H TRAVEL TIME — EMPTY**

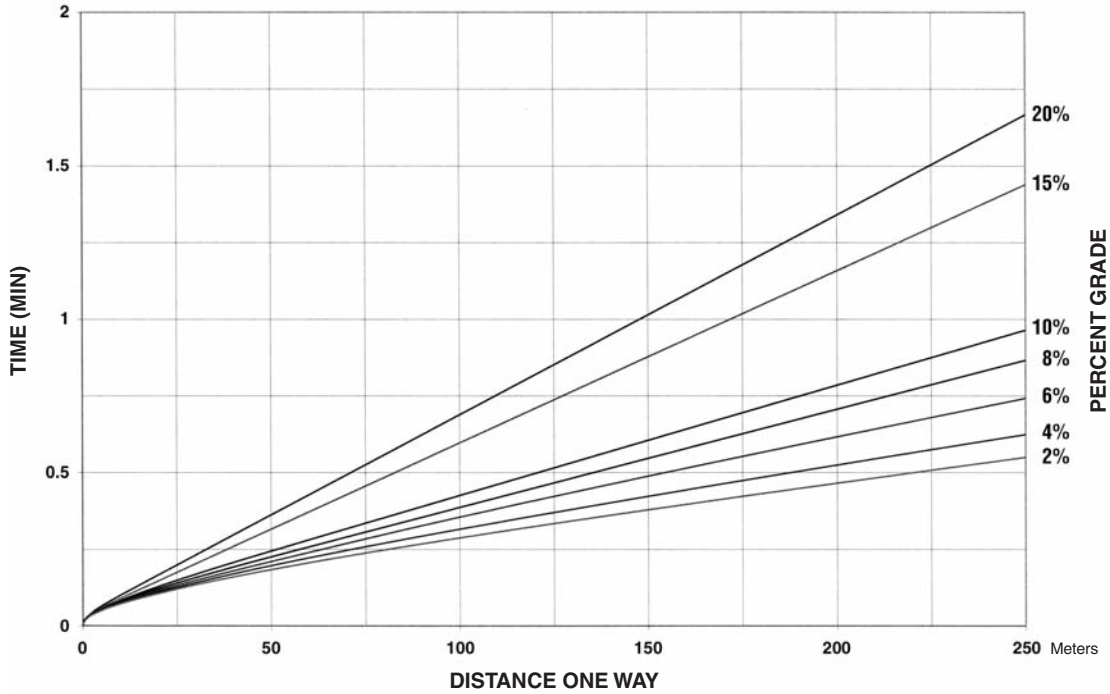

Travel times assume maximum governor pedal depression and automatic shifting for any VSC setting.

In load and carry applications it is important to consult the tire manufacturer on Ton-MPH ratings and pressure recommendations.

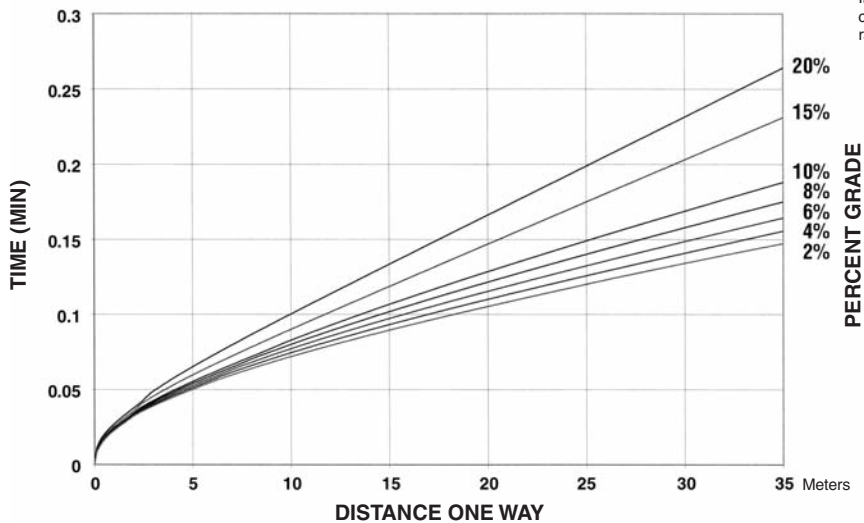

Travel Time — Loaded  
 ● 966H  
 ● 26.5-25 Tires

**Wheel Loaders  
 Integrated Toolcarriers**

**966H TRAVEL TIME — LOADED**

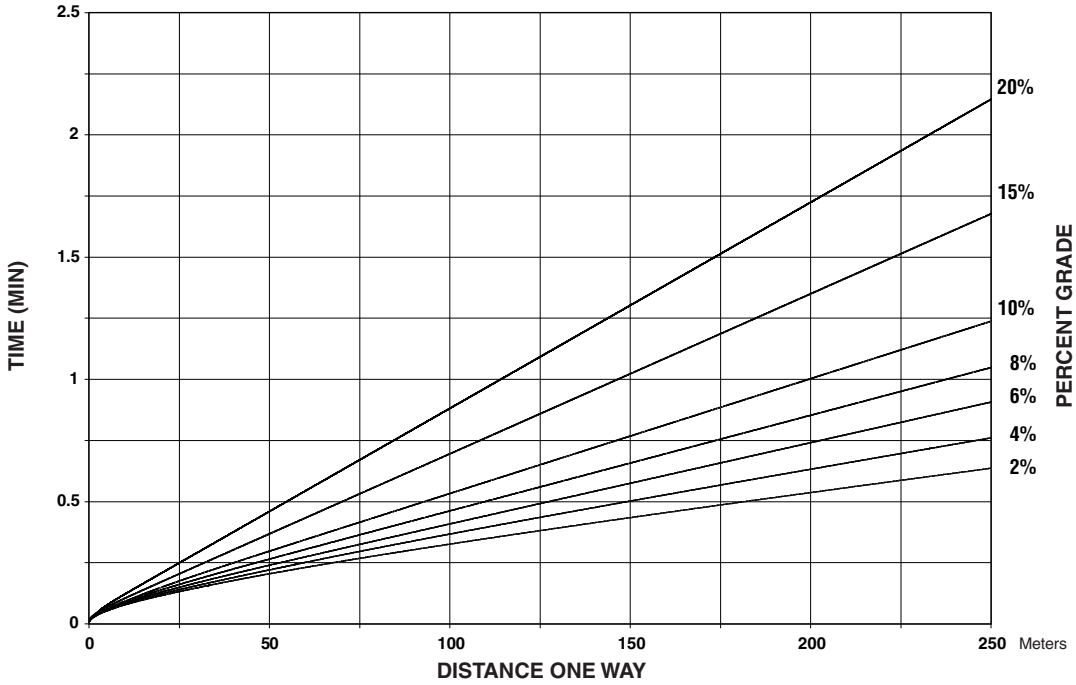

Travel times assume maximum governor pedal depression and automatic shifting for any VSC setting.

In load and carry applications it is important to consult the tire manufacturer on Ton-MPH ratings and pressure recommendations.

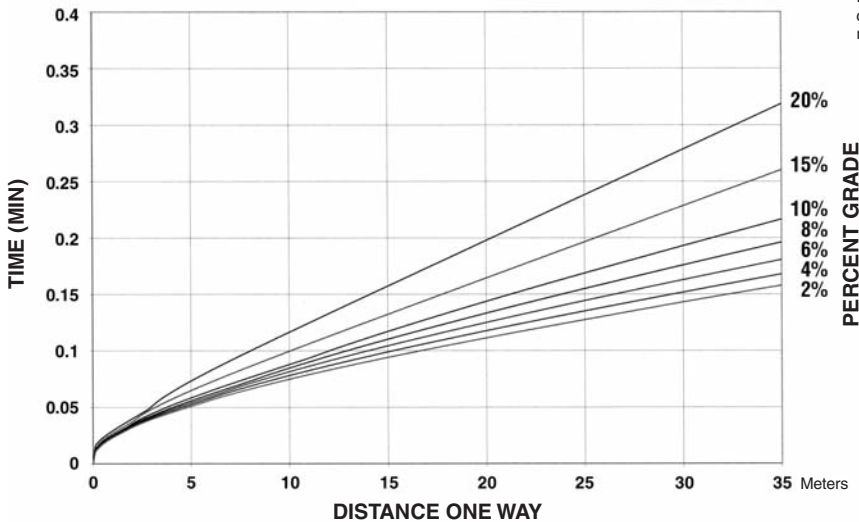



- 966H
- 26.5-25 Tires

**966H TRAVEL TIME — EMPTY**

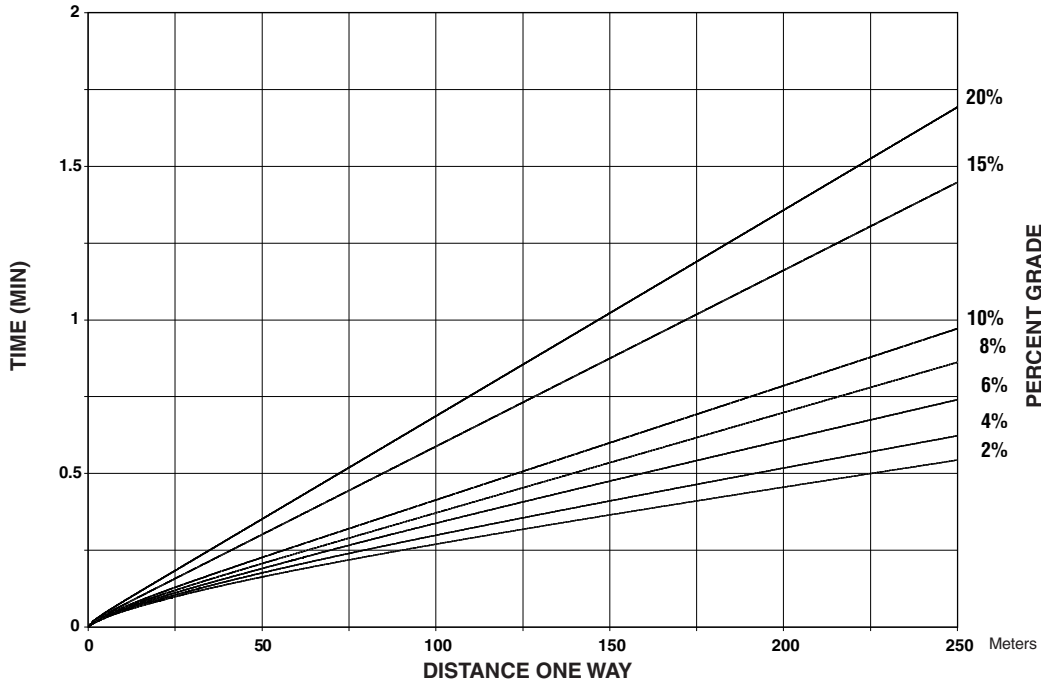

Travel times assume maximum governor pedal depression and automatic shifting for any VSC setting.

In load and carry applications it is important to consult the tire manufacturer on Ton-MPH ratings and pressure recommendations.

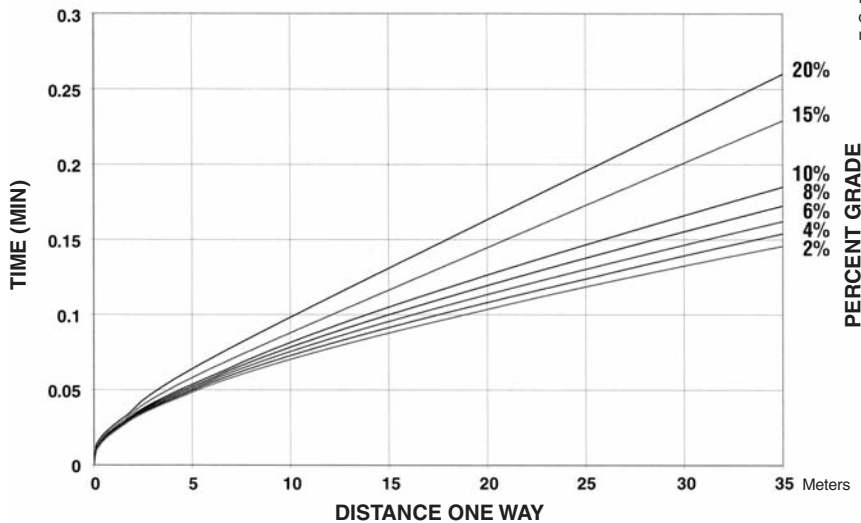

Travel Time — Loaded  
 ● 972H  
 ● 26.5-25 Tires

**Wheel Loaders  
 Integrated Toolcarriers**

**972H TRAVEL TIME — LOADED**

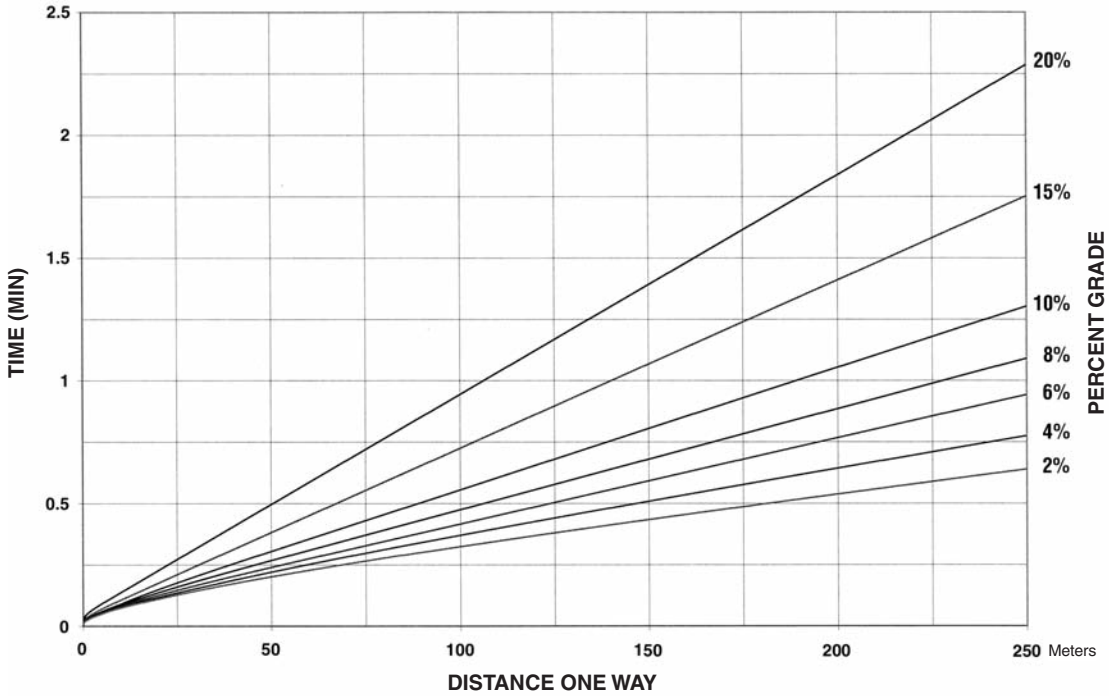

Travel times assume maximum governor pedal depression and automatic shifting for any VSC setting.

In load and carry applications it is important to consult the tire manufacturer on Ton-MPH ratings and pressure recommendations.

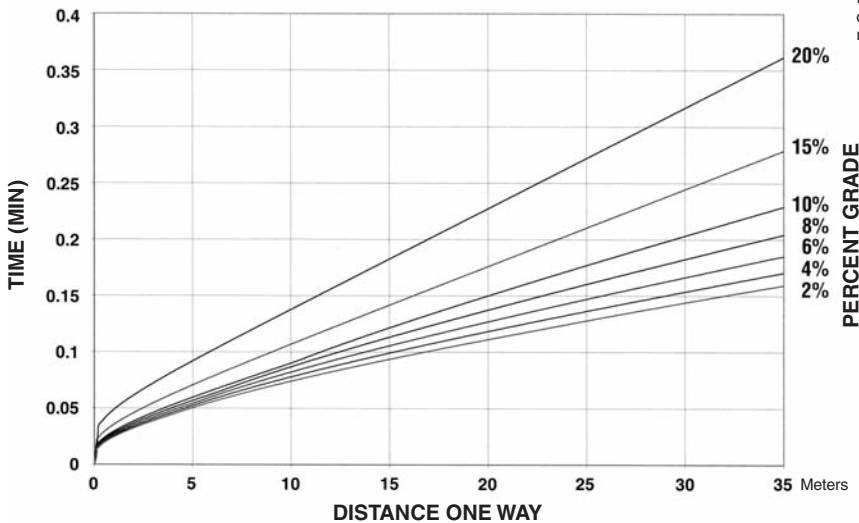

**972H TRAVEL TIME — EMPTY**

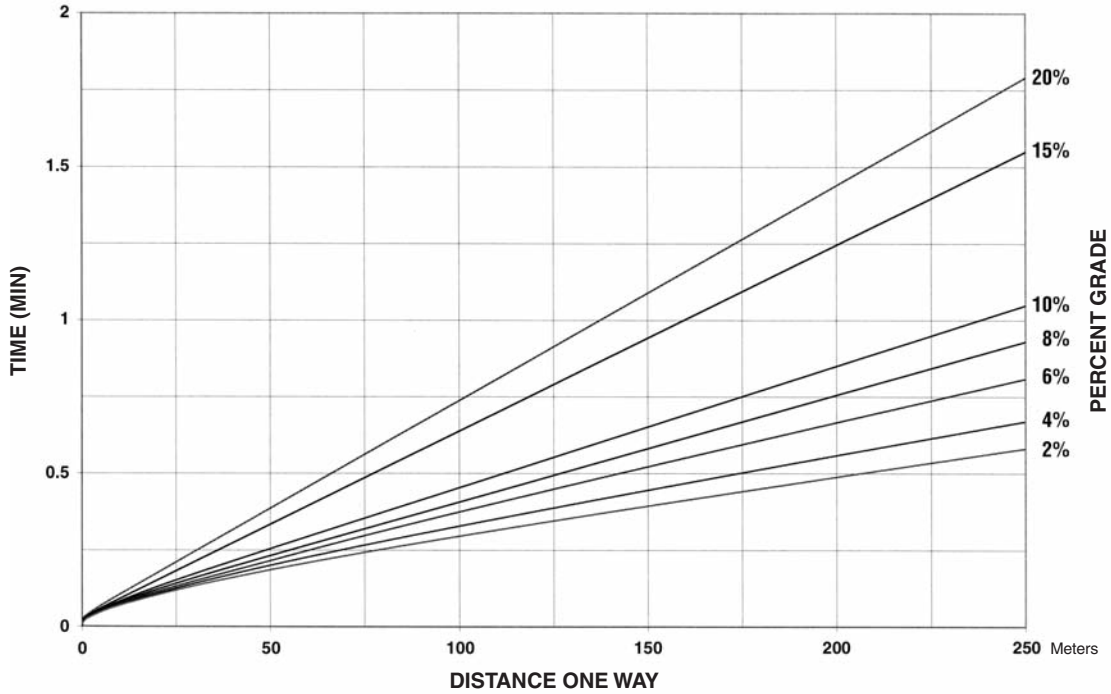

Travel times assume maximum governor pedal depression and automatic shifting for any VSC setting.

In load and carry applications it is important to consult the tire manufacturer on Ton-MPH ratings and pressure recommendations.

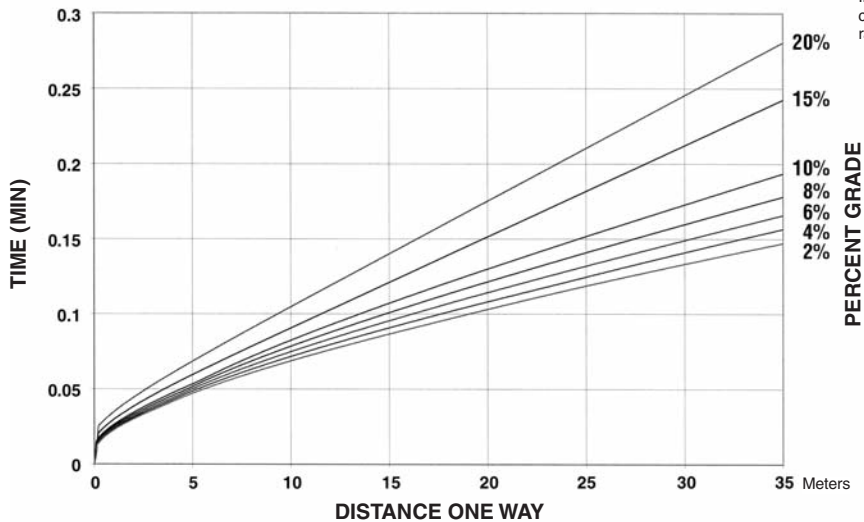

Travel Time — Loaded  
 ● 980H  
 ● 29.5R25 Tires

**Wheel Loaders  
 Integrated Toolcarriers**

**980H TRAVEL TIME — LOADED**

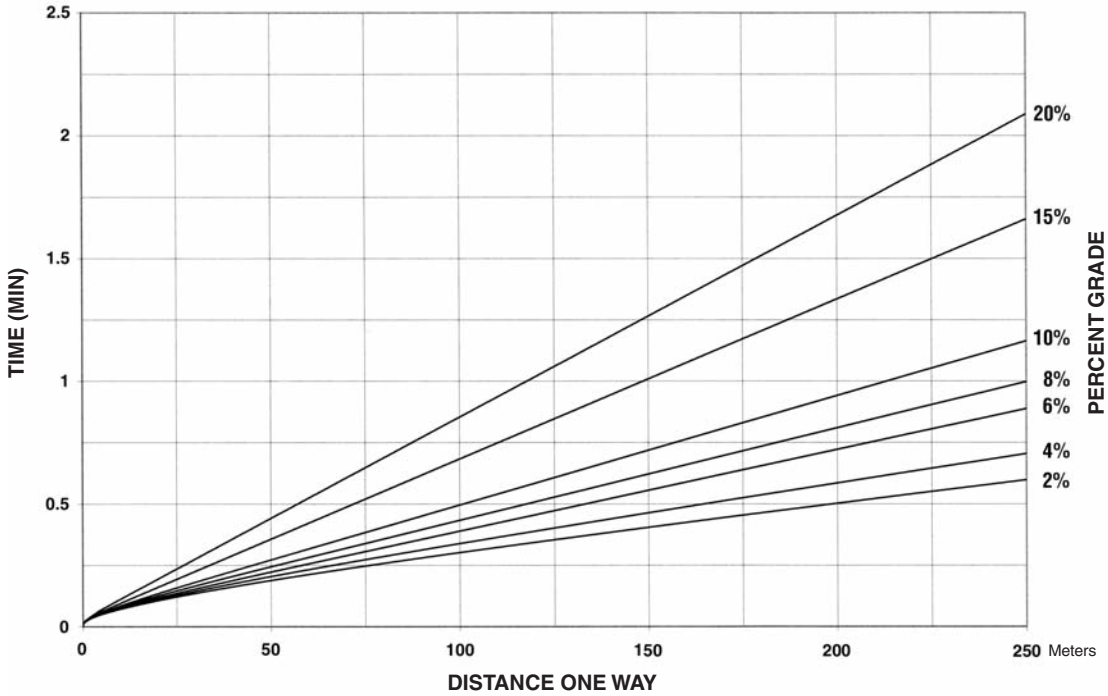

Travel times assume maximum governor pedal depression and automatic shifting for any VSC setting.

In load and carry applications it is important to consult the tire manufacturer on Ton-MPH ratings and pressure recommendations.

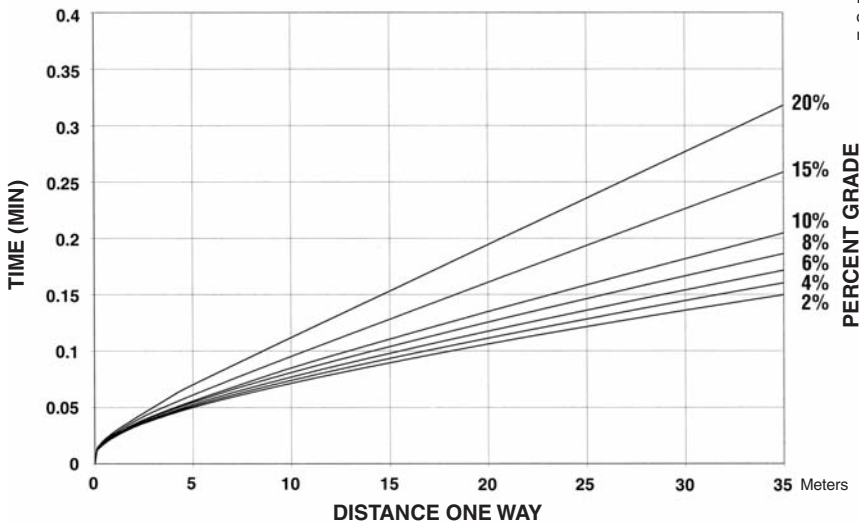

**980H TRAVEL TIME — EMPTY**

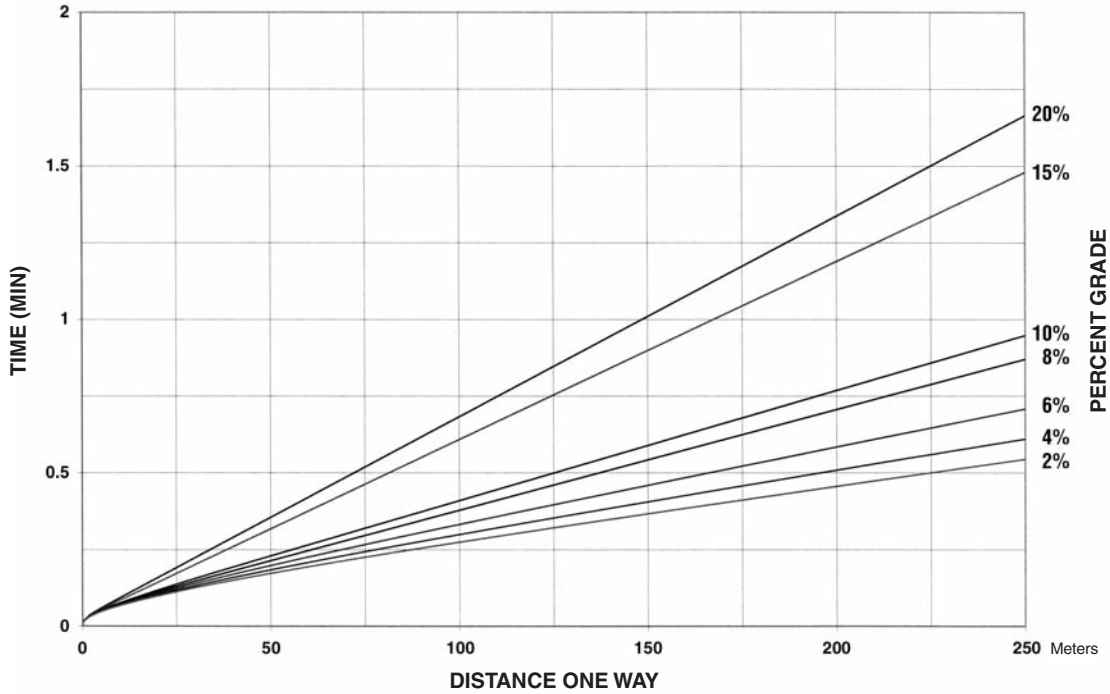

Travel times assume maximum governor pedal depression and automatic shifting for any VSC setting.

In load and carry applications it is important to consult the tire manufacturer on Ton-MPH ratings and pressure recommendations.

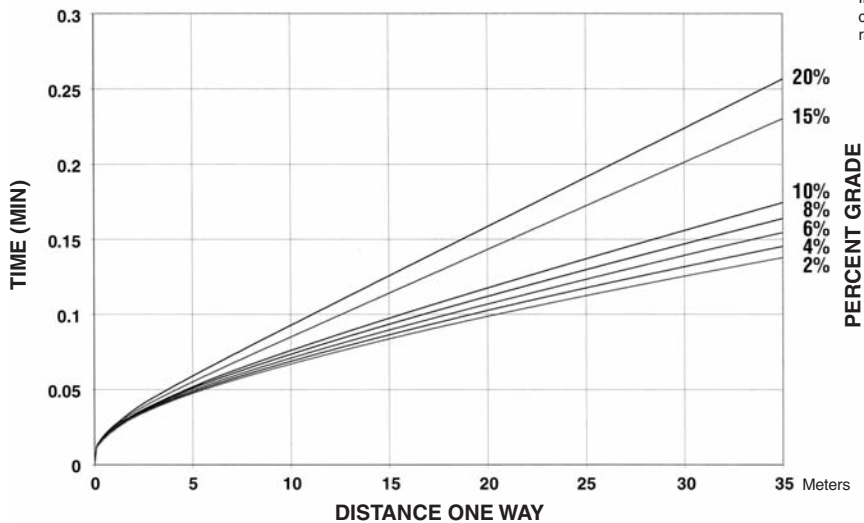

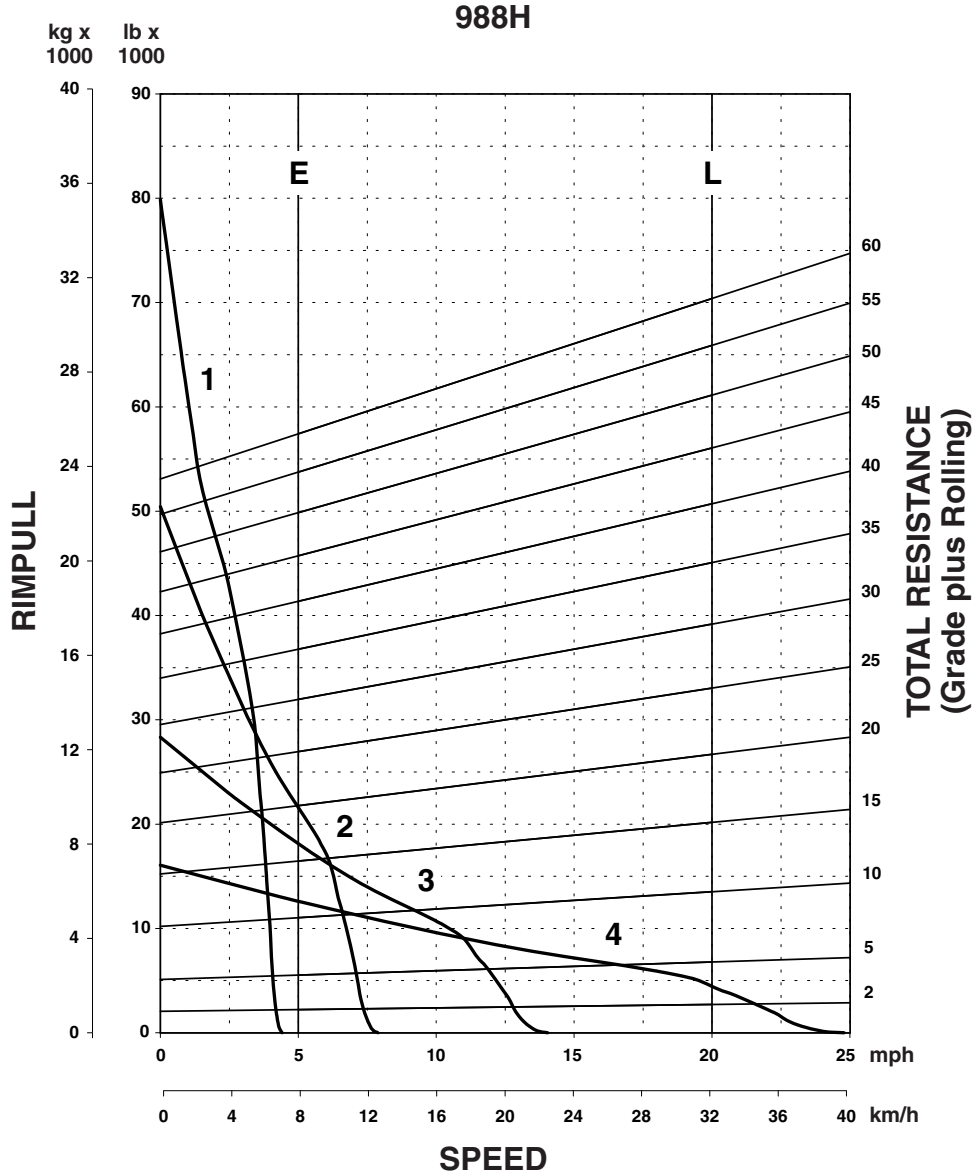

**KEY**

- 1 — 1st Gear
- 2 — 2nd Gear
- 3 — 3rd Gear
- 4 — 4th Gear

**KEY**

- E — Empty 50 183 kg (110,634 lb)
- L — Loaded 61 523 kg (135,634 lb)

Calculated Pull: Idle Hydraulics  
 Curves Assume NO SLIP Conditions

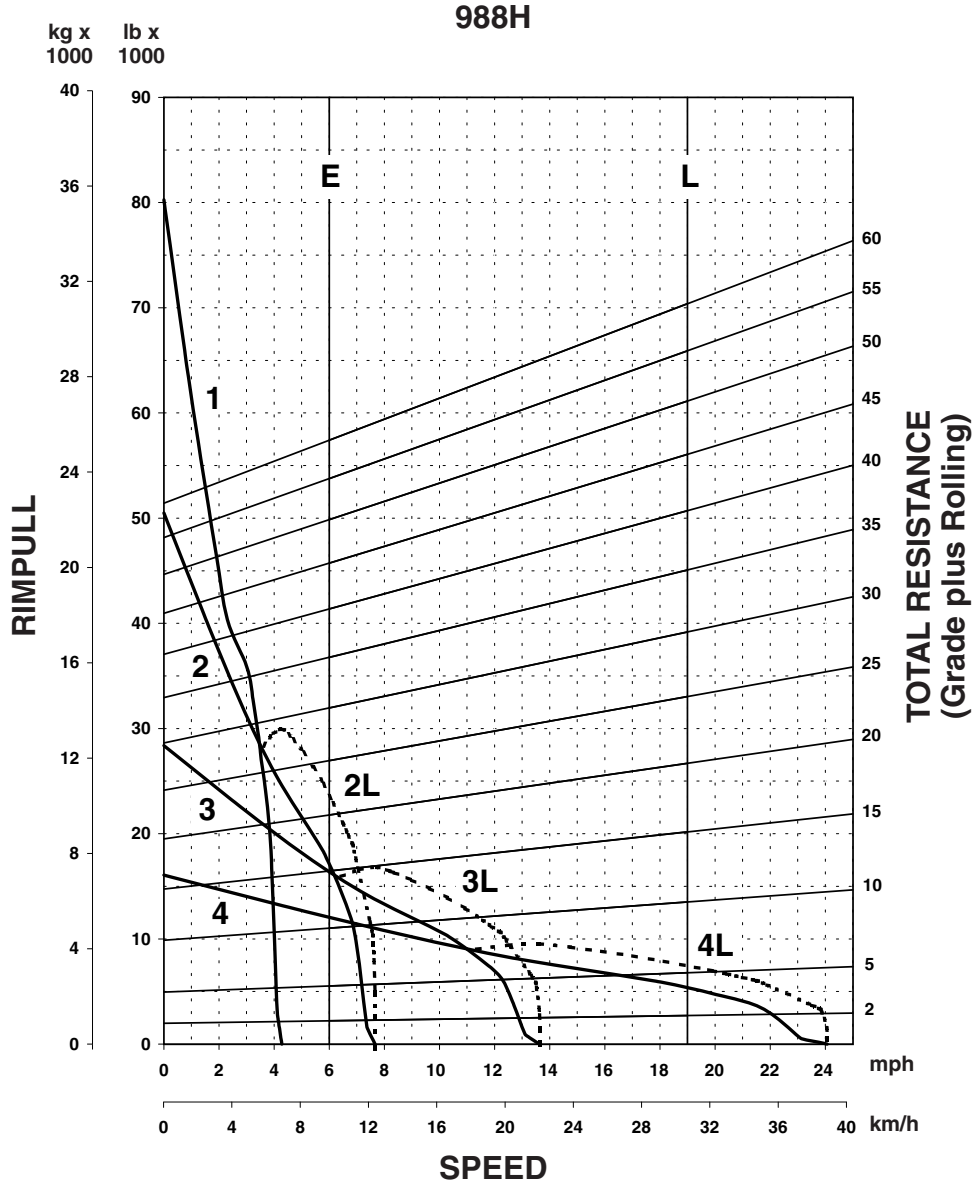

Travel Time — Loaded  
 ● 988H — No Lock-Up  
 ● 35/65-33 Tires

**Wheel Loaders  
 Integrated Toolcarriers**

**988H TRAVEL TIME — LOADED**

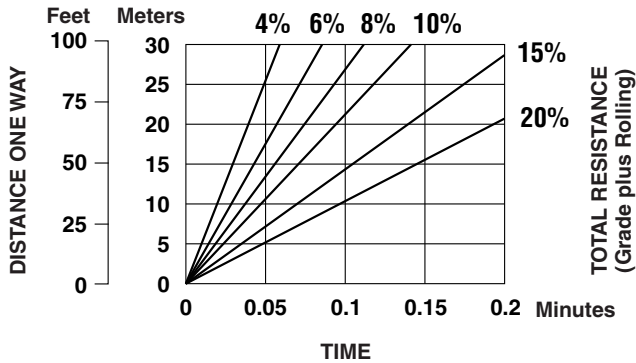
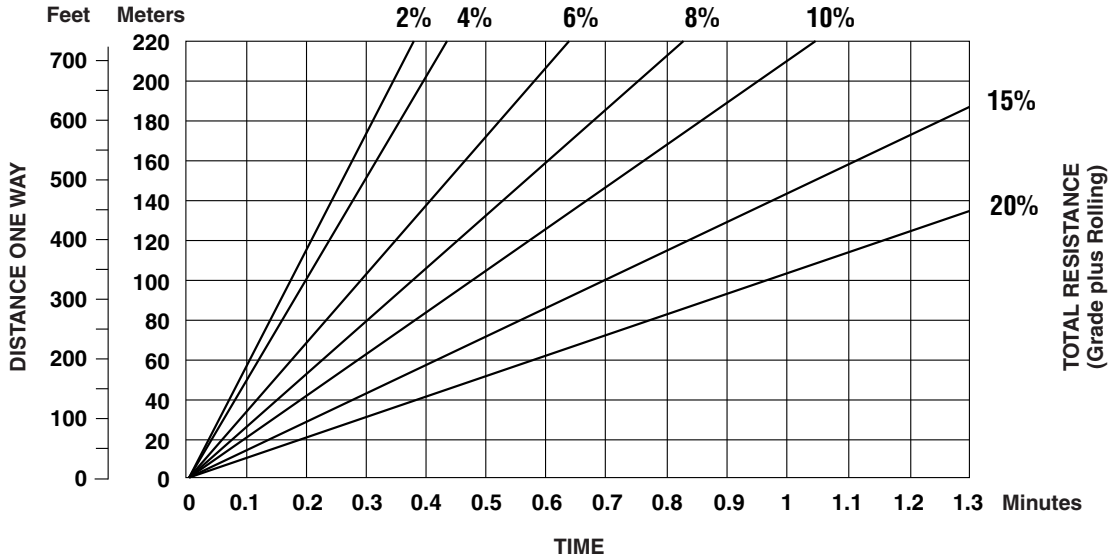

**NOTE:** Curves assume use of highest operating speed attainable: 4th gear for 2%-6% TR, 3rd gear for 8%-10% TR, 2nd gear for 15% and 20% TR.

In load-and-carry applications it is important to consult the tire manufacturer on Ton-MPH ratings and pressure recommendations.

Lock-Up Clutch torque converter is available as an attachment. Contact your Cat dealer for additional information.



**988H TRAVEL TIME — EMPTY**

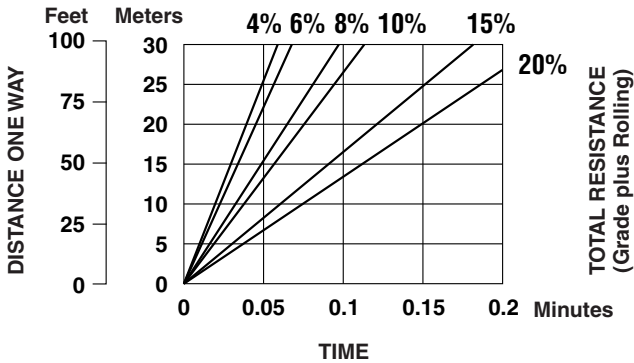
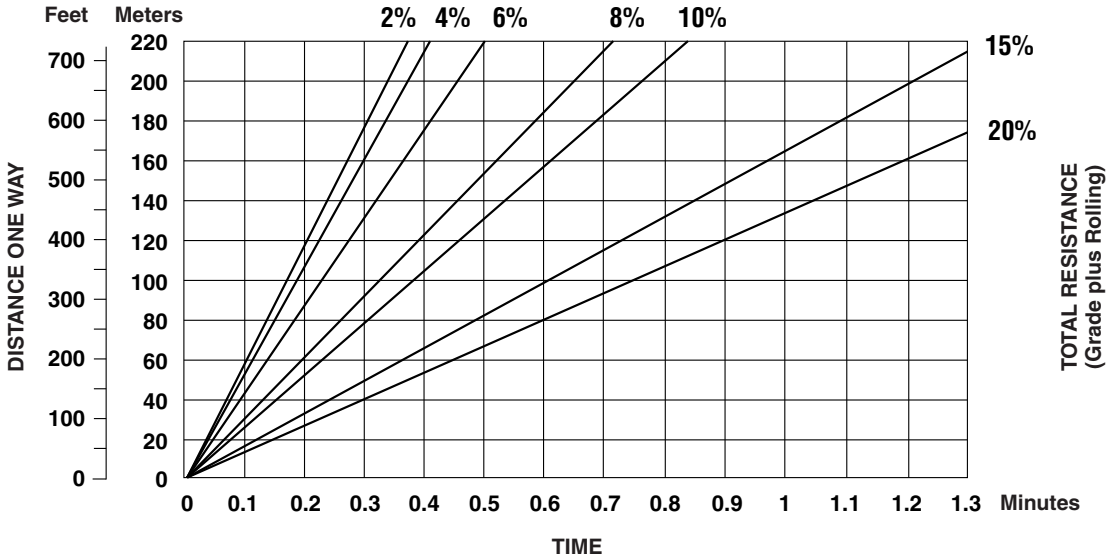

**NOTE:** Curves assume use of highest operating speed attainable: 4th gear for 2%-8% TR, 3rd gear for 10% TR, 2nd gear for 15% and 20% TR.

In load-and-carry applications it is important to consult the tire manufacturer on Ton-MPH ratings and pressure recommendations.

Lock-Up Clutch torque converter is available as an attachment. Contact your Cat dealer for additional information.

- Travel Time — Loaded
- 988H — Lock-Up Clutch
- 35/65-33 Tires

## Wheel Loaders Integrated Toolcarriers

### 988H TRAVEL TIME — LOADED

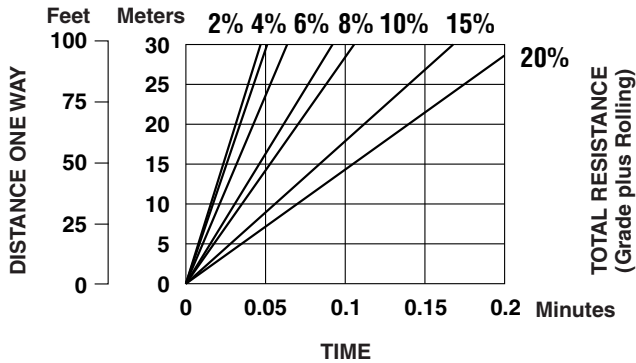
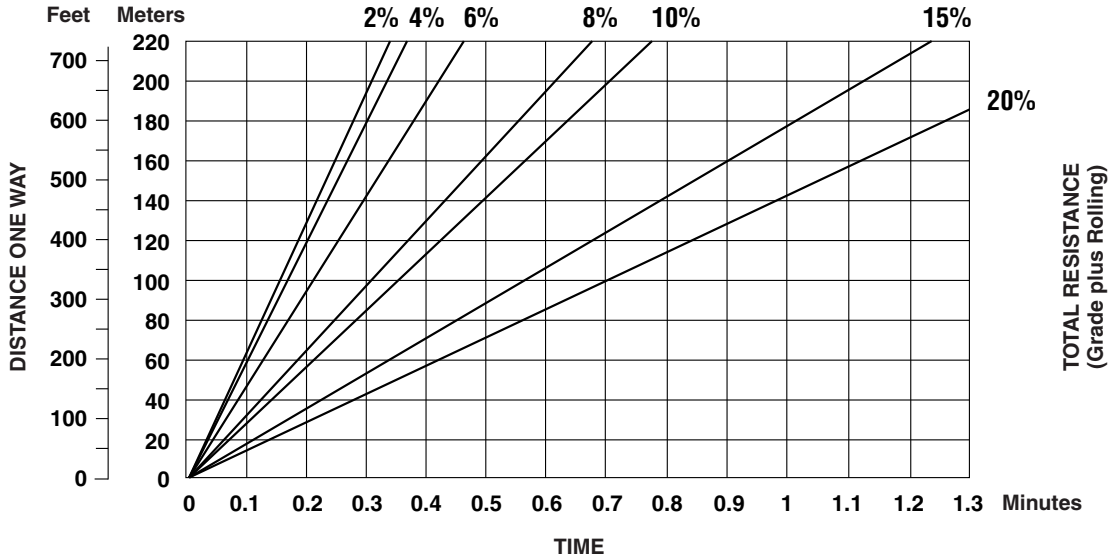

**NOTE:** Curves assume use of highest operating speed attainable: 4th gear for 2%-6% TR, 3rd gear for 8%-10% TR, 2nd gear for 15% and 20% TR.

In load-and-carry applications it is important to consult the tire manufacturer on Ton-MPH ratings and pressure recommendations.

Lock-Up Clutch torque converter is available as an attachment. Contact your Cat dealer for additional information.

**988H TRAVEL TIME — EMPTY**

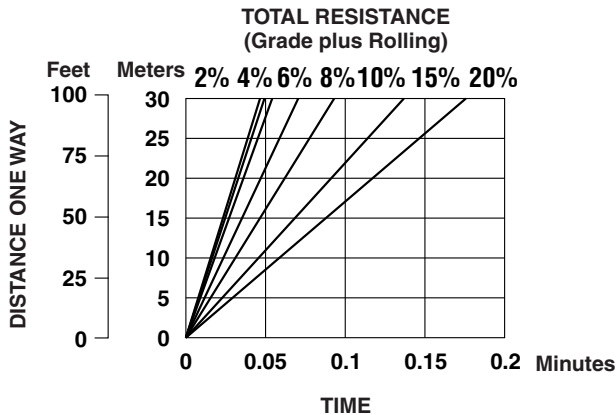
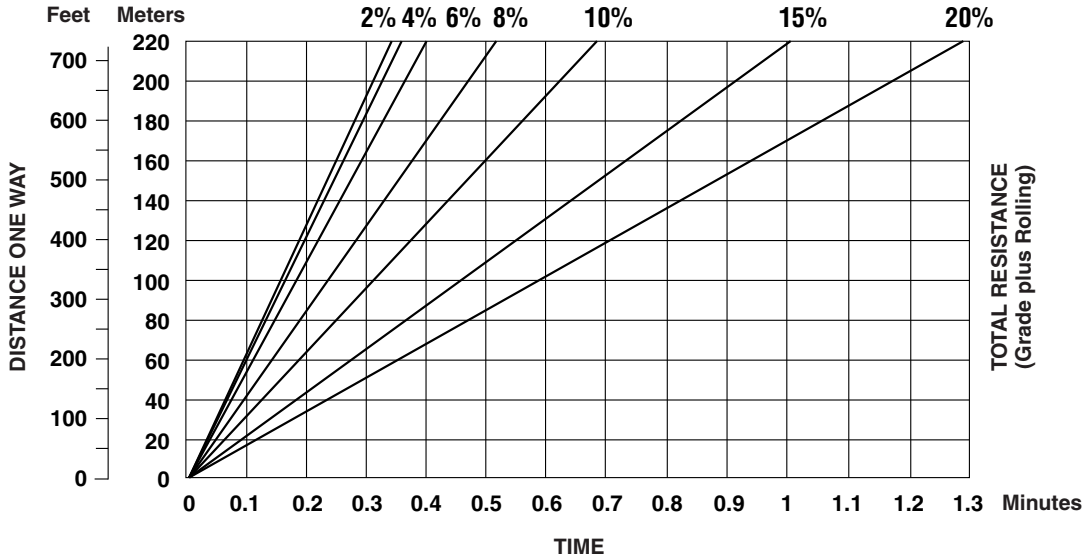

**NOTE:** Curves assume use of highest operating speed attainable: 4th gear for 2%-8% TR, 3rd gear for 10%-15% TR, 2nd gear for 20% TR.

In load-and-carry applications it is important to consult the tire manufacturer on Ton-MPH ratings and pressure recommendations.

Lock-Up Clutch torque converter is available as an attachment. Contact your Cat dealer for additional information.

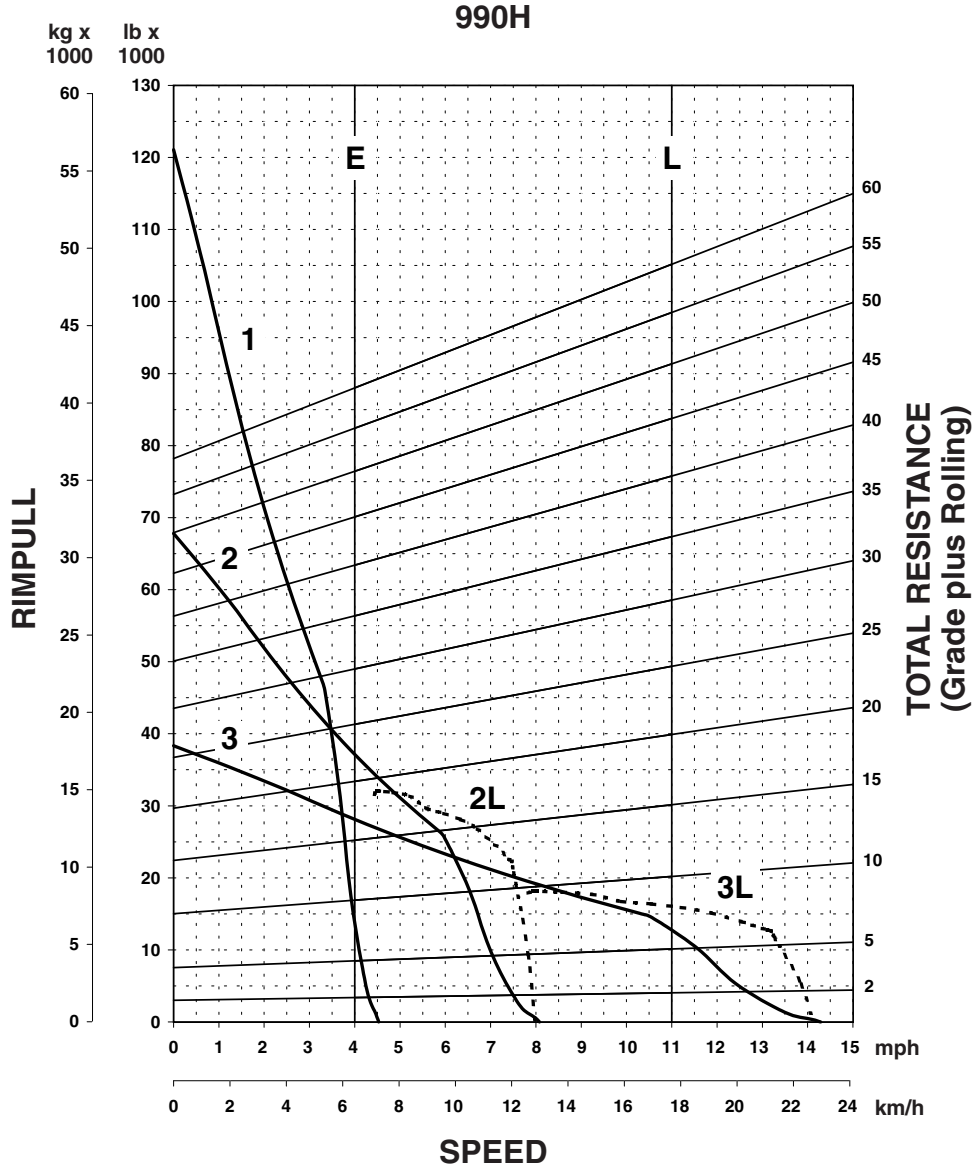

**KEY**

- 1 — 1st Gear
- 2 — 2nd Gear
- 3 — 3rd Gear

**KEY**

- E — Empty 76 965 kg (169,677 lb)
- L — Loaded 91 934 kg (202,677 lb)

Calculated Pull: Idle Hydraulics  
Curves Assume NO SLIP Conditions

- 990H
- 41.25/70-39 Tires

**990H TRAVEL TIME — LOADED**

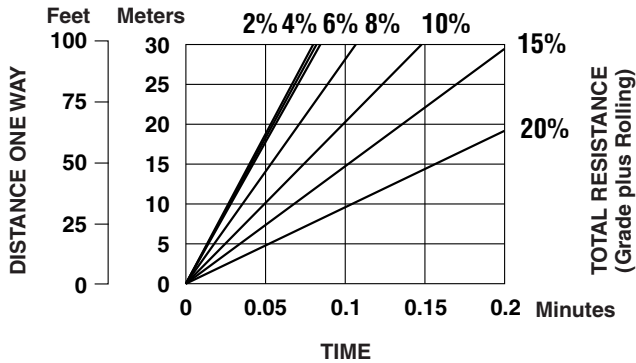
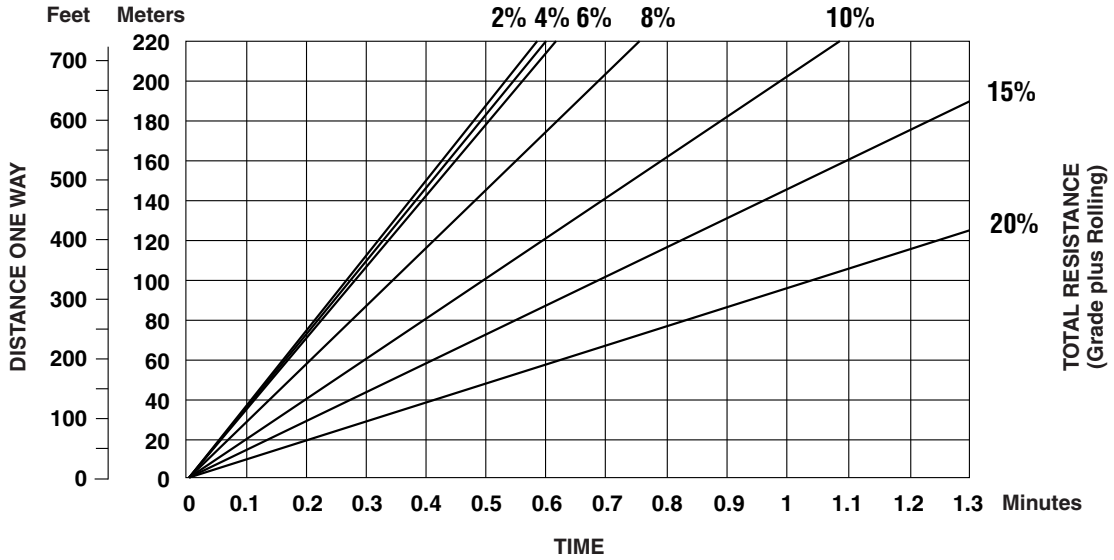

**NOTE:** Curves assume use of highest operating speed attainable: 3rd gear for 2%-8% TR, 2nd gear for 10%-20% TR.

In load-and-carry applications it is important to consult the tire manufacturer on Ton-MPH ratings and pressure recommendations.

Travel Time — Empty  
 ● 990H  
 ● 41.25/70-39 Tires

**Wheel Loaders  
 Integrated Toolcarriers**

**990H TRAVEL TIME — EMPTY**

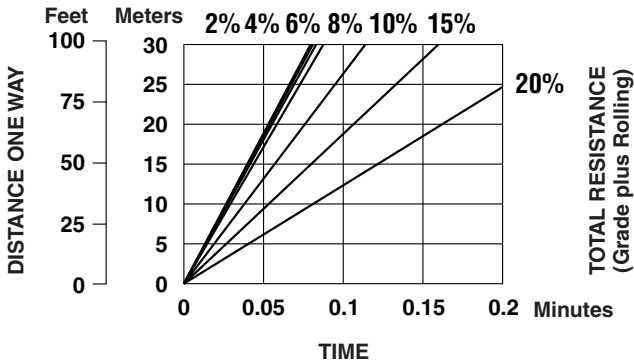
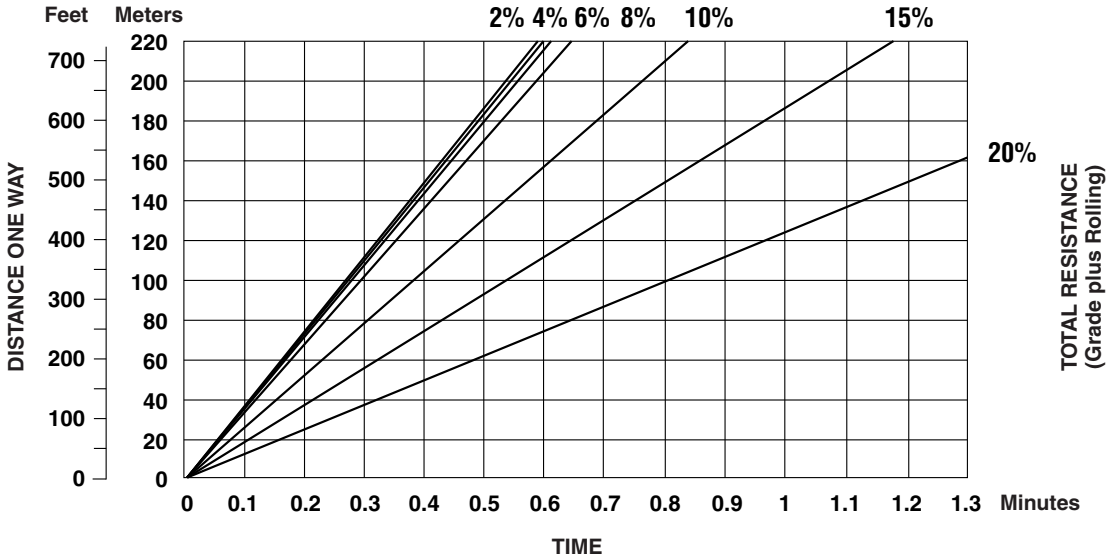

**NOTE:** Curves assume use of highest operating speed attainable: 3rd gear for 2%-10% TR, 2nd gear for 15% and 20% TR.

In load-and-carry applications it is important to consult the tire manufacturer on Ton-MPH ratings and pressure recommendations.

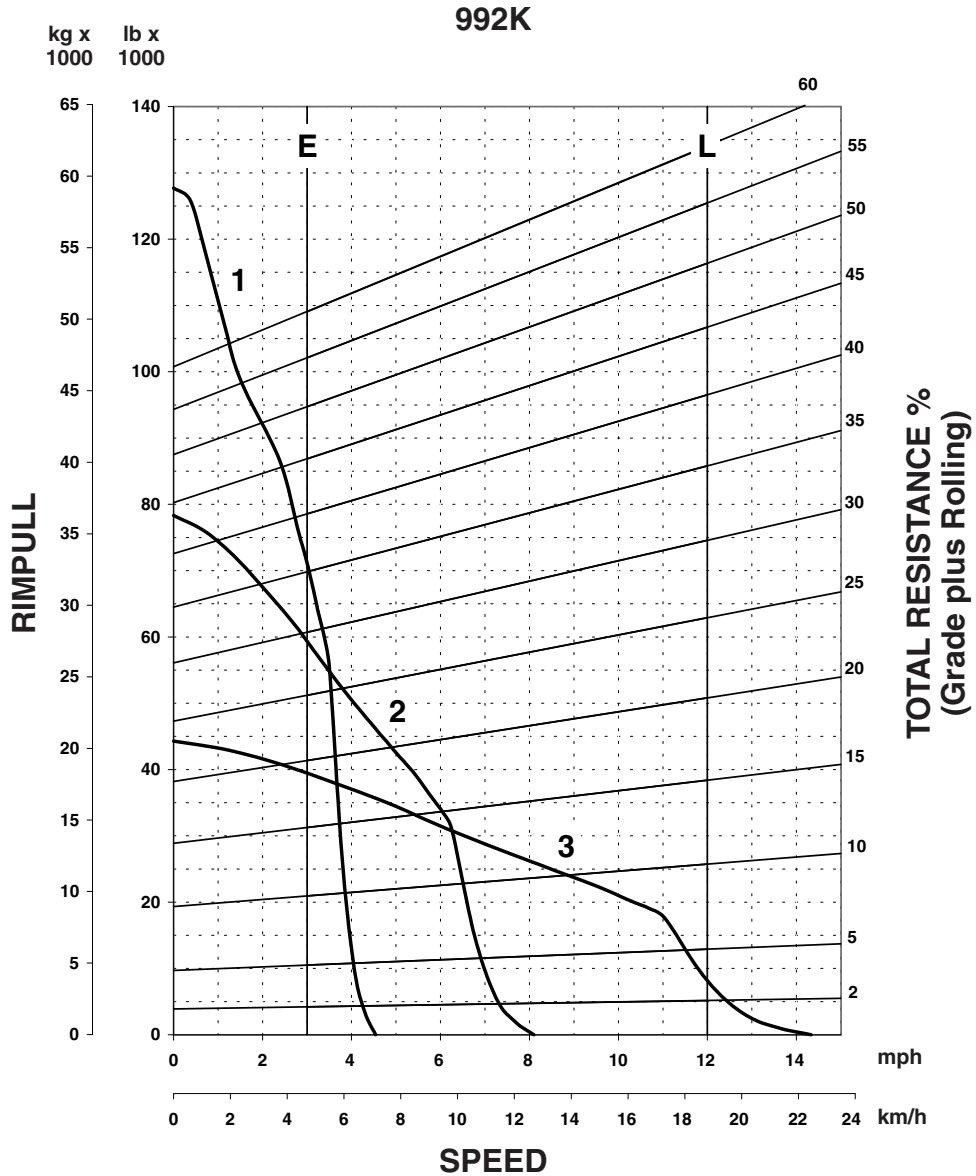

**KEY**

- 1 — 1st Gear
- 2 — 2nd Gear
- 3 — 3rd Gear

**KEY**

- E — Empty 92 797 kg (204,580 lb)
- L — Loaded 114 570 kg (252,580 lb)

Calculated Pull: Idle Hydraulics  
Curves Assume NO SLIP Conditions

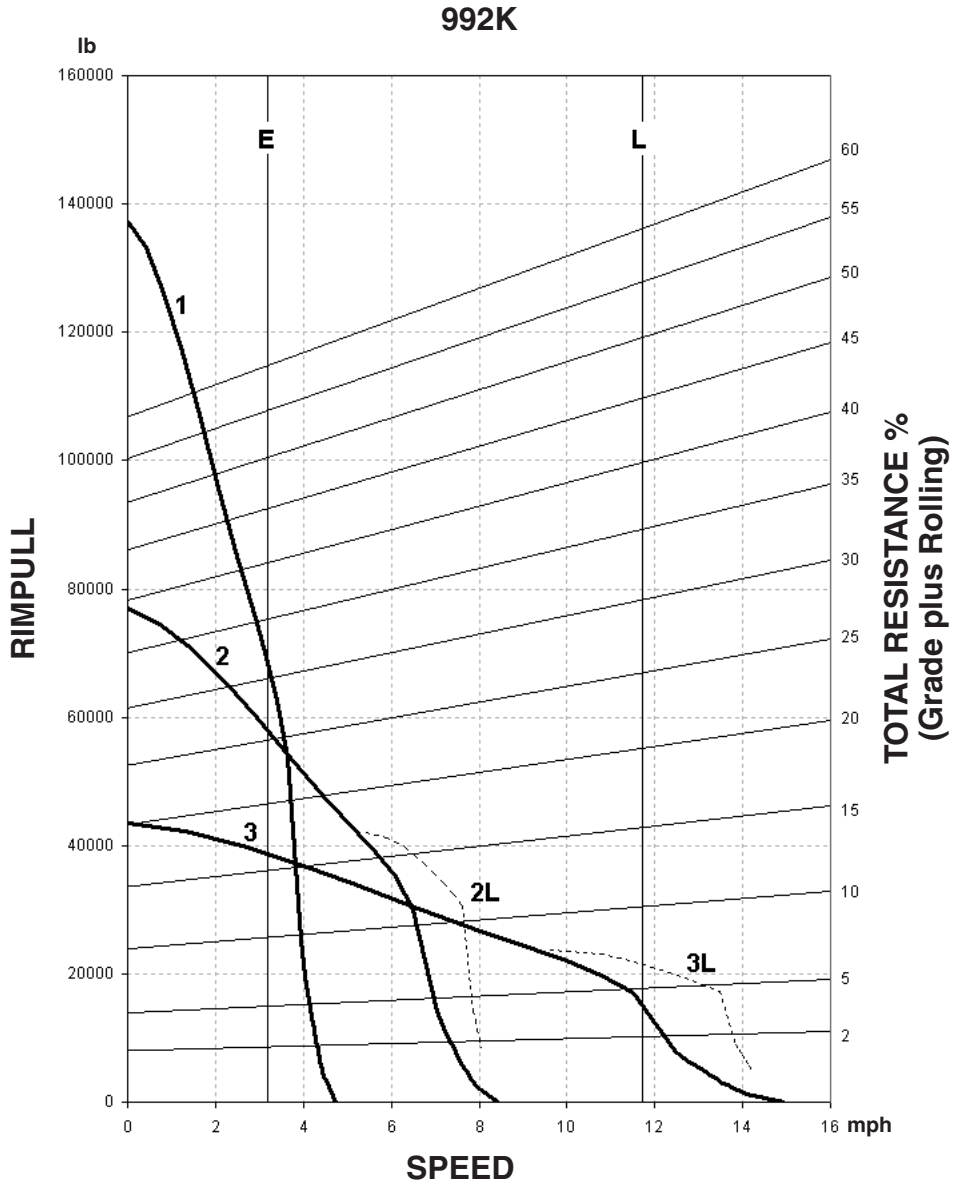

**KEY**

- 1 — 1st Gear
- 2 — 2nd Gear
- 3 — 3rd Gear

**KEY**

- E — Empty 92 797 kg (204,580 lb)
- L — Loaded 114 570 kg (252,580 lb)

Calculated Pull: Idle Hydraulics  
 Curves Assume NO SLIP Conditions



- 992K
- 45/65-45 Tires

**992K TRAVEL TIME — LOADED**

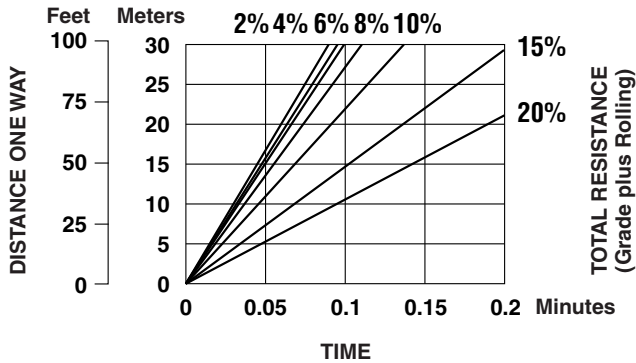
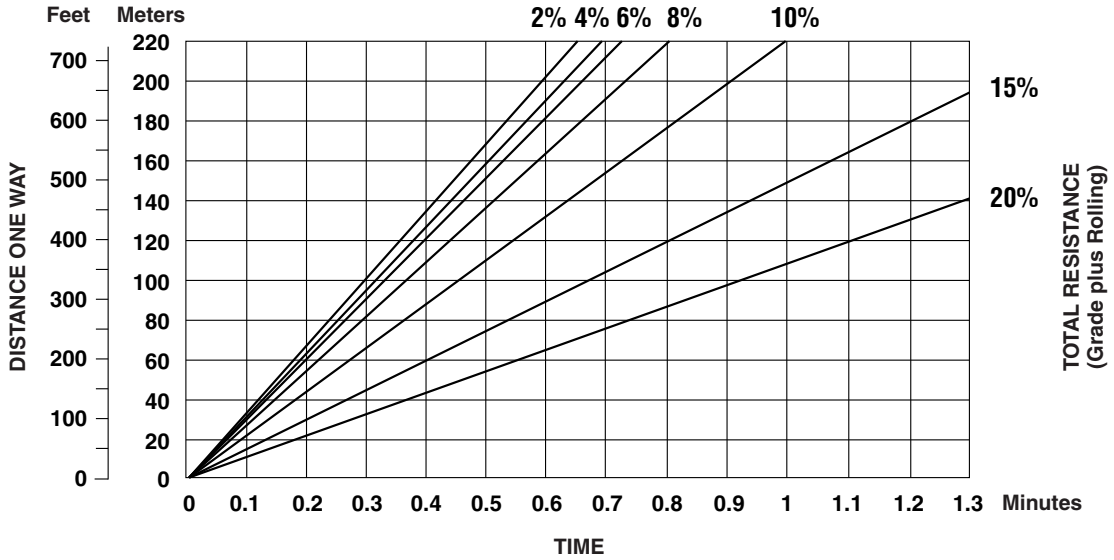

**NOTE:** Curves assume use of highest operating speed attainable: 3rd gear for 2%-10% TR, 2nd gear for 15% and 20% TR.

In load-and-carry applications it is important to consult the tire manufacturer on Ton-MPH ratings and pressure recommendations.

Travel Time — Empty  
 ● 992K  
 ● 45/65-45 Tires

**Wheel Loaders  
 Integrated Toolcarriers**

**992K TRAVEL TIME — EMPTY**

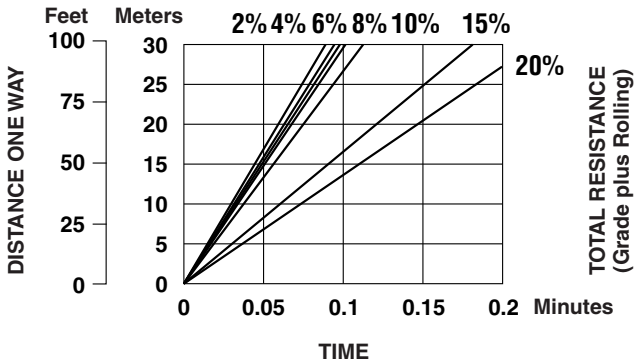
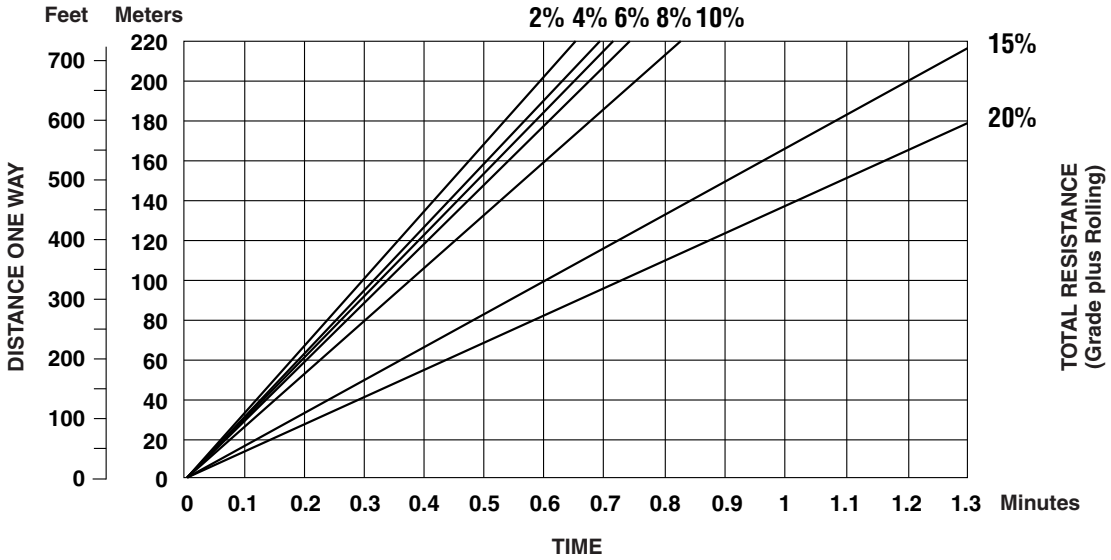

**NOTE:** Curves assume use of highest operating speed attainable: 3rd gear for 2%-10% TR, 2nd gear for 15% and 20% TR.

In load-and-carry applications it is important to consult the tire manufacturer on Ton-MPH ratings and pressure recommendations.

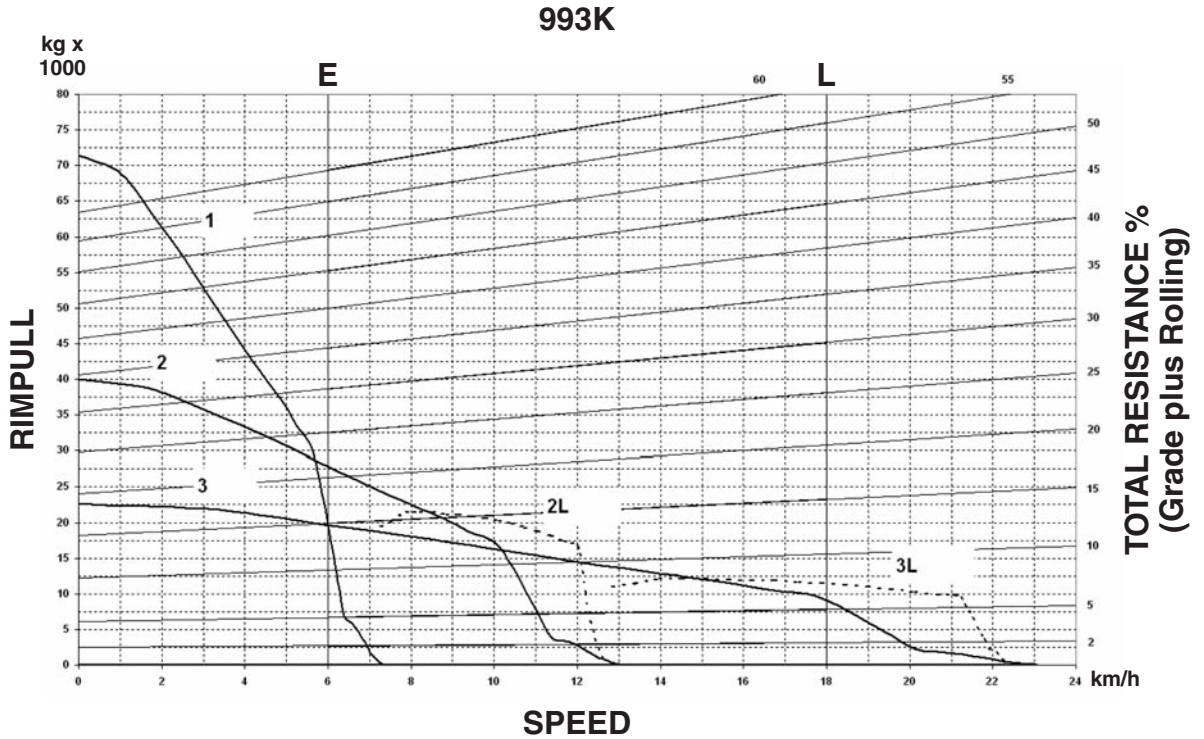

**KEY**  
1— 1st Gear  
2— 2nd Gear  
3— 3rd Gear

**KEY**  
E — Empty  
L — Loaded

Calculated Pull: Idle Hydraulics  
Curves Assume NO SLIP Conditions

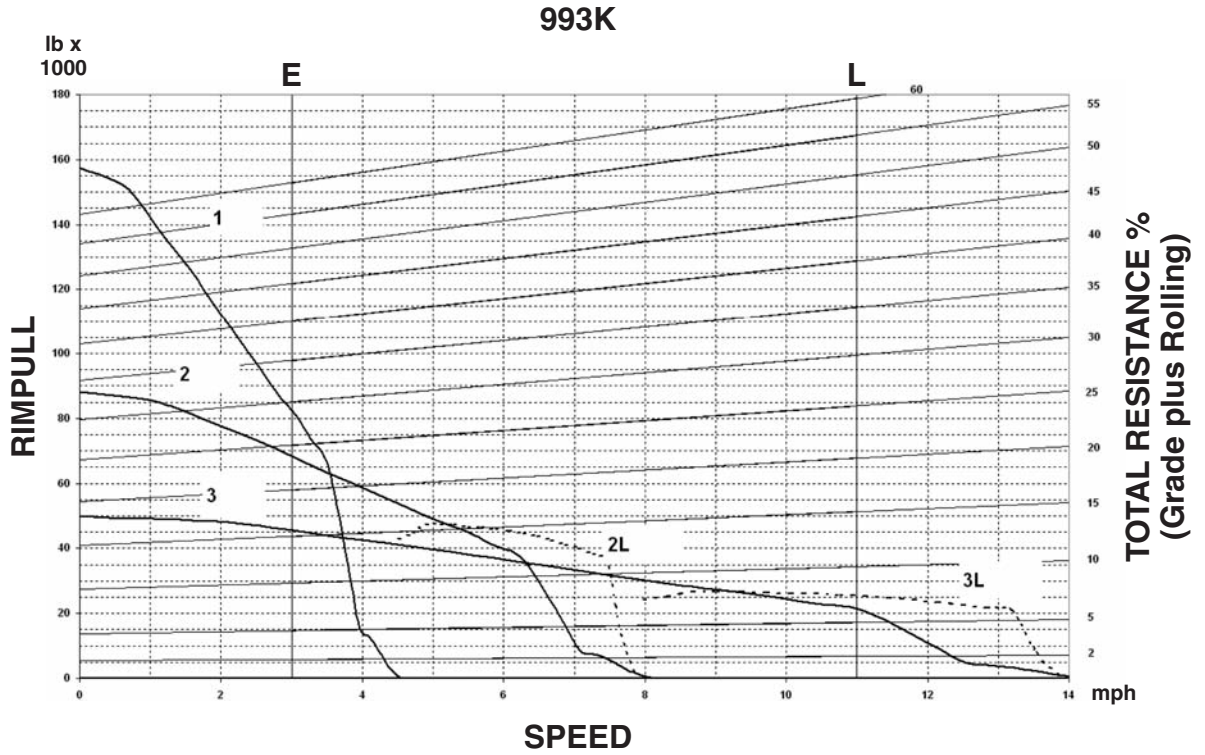

**KEY**  
 1— 1st Gear  
 2— 2nd Gear  
 3— 3rd Gear

**KEY**  
 E — Empty  
 L — Loaded

Calculated Pull: Idle Hydraulics  
 Curves Assume NO SLIP Conditions

### 993K TRAVEL TIME — EMPTY

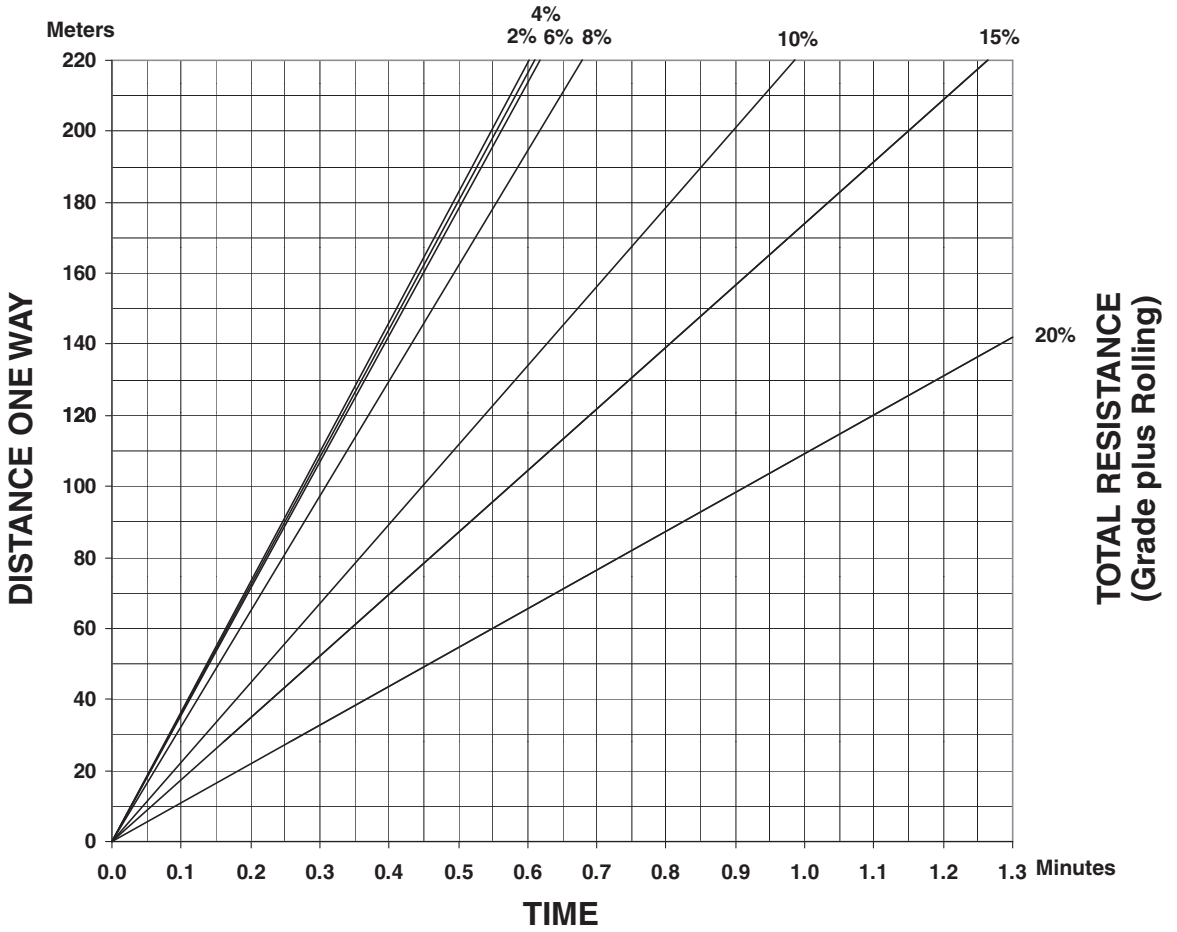

- Travel Time — Loaded
- 993K — Lock-Up Clutch
- Idle Hydraulics

**Wheel Loaders  
Integrated Toolcarriers**

**993K TRAVEL TIME — LOADED**

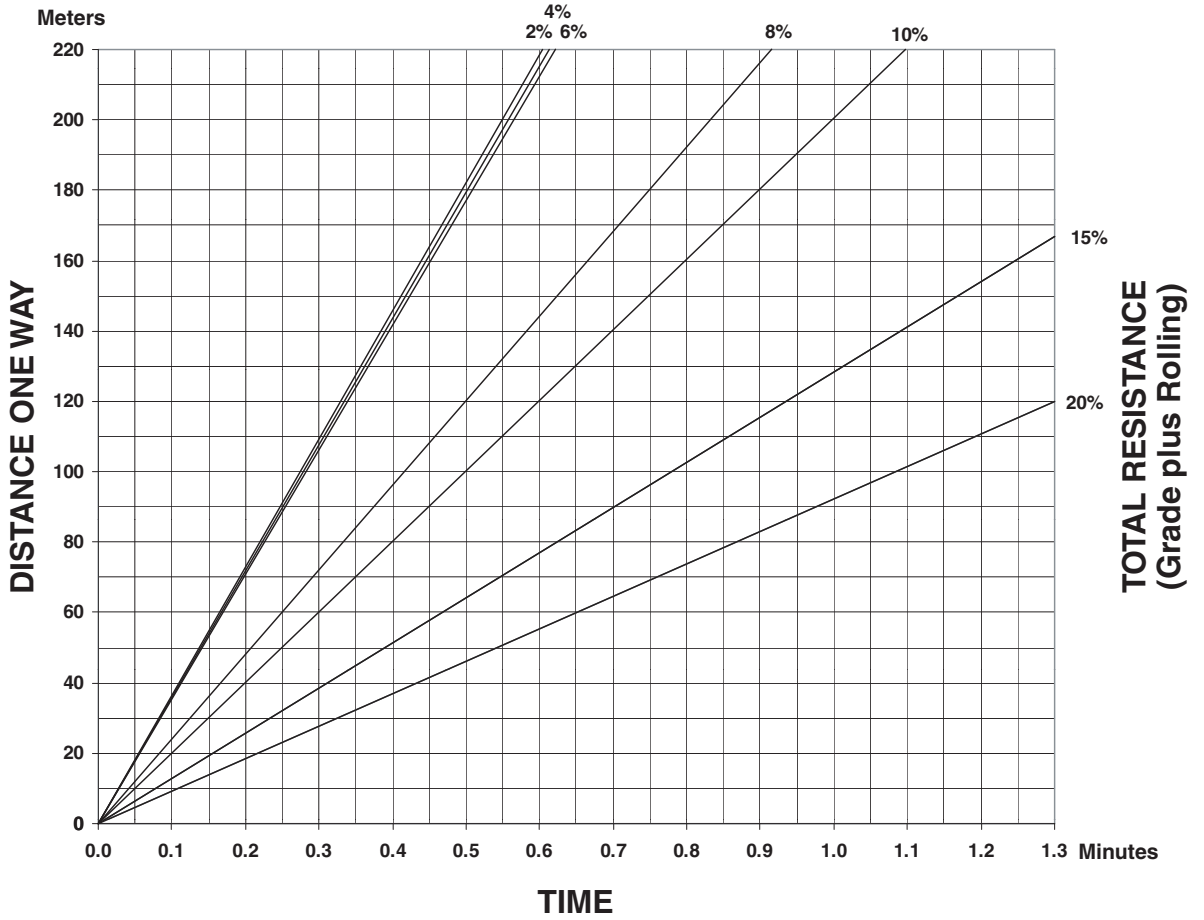

993K TRAVEL TIME — EMPTY

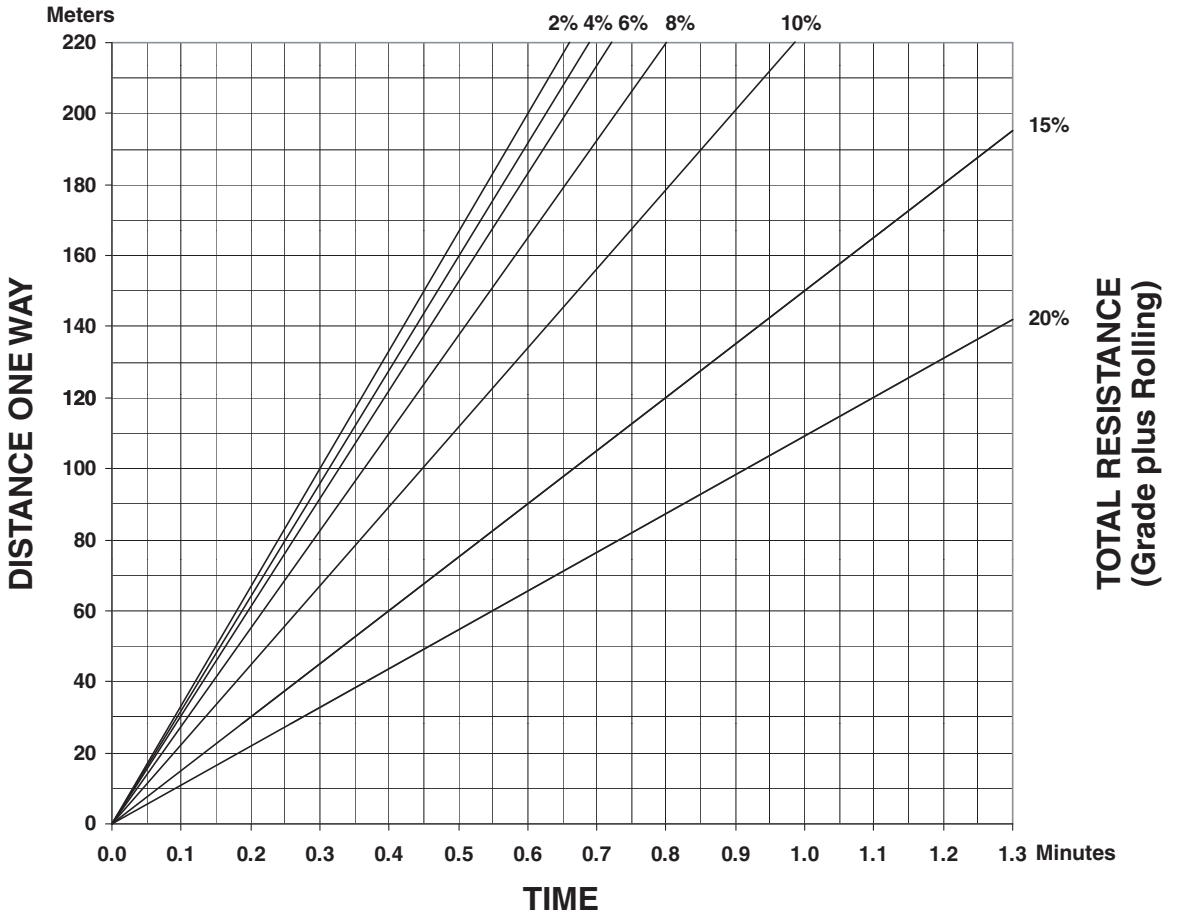

Travel Time — Loaded  
 ● 993K — Standard  
 ● Idle Hydraulics

Wheel Loaders  
 Integrated Toolcarriers

### 993K TRAVEL TIME — LOADED

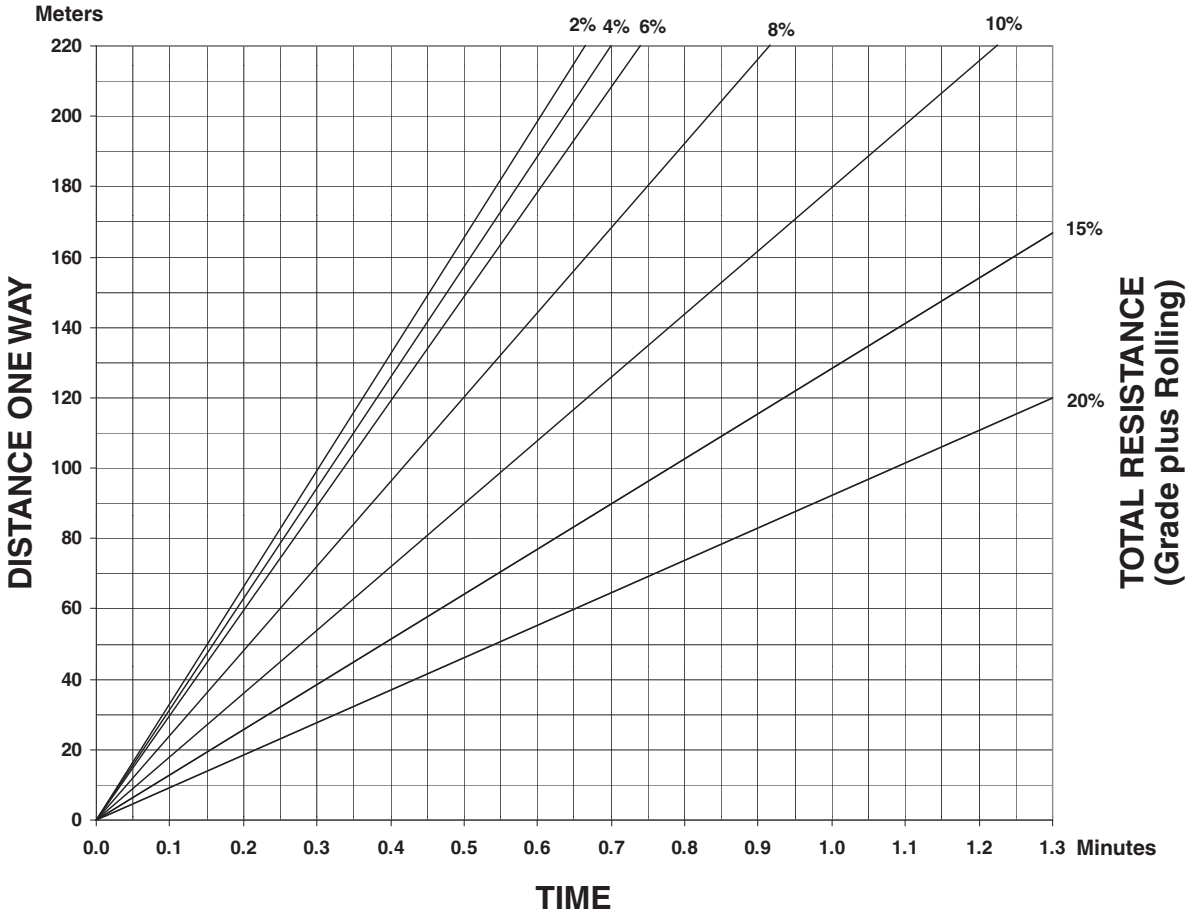



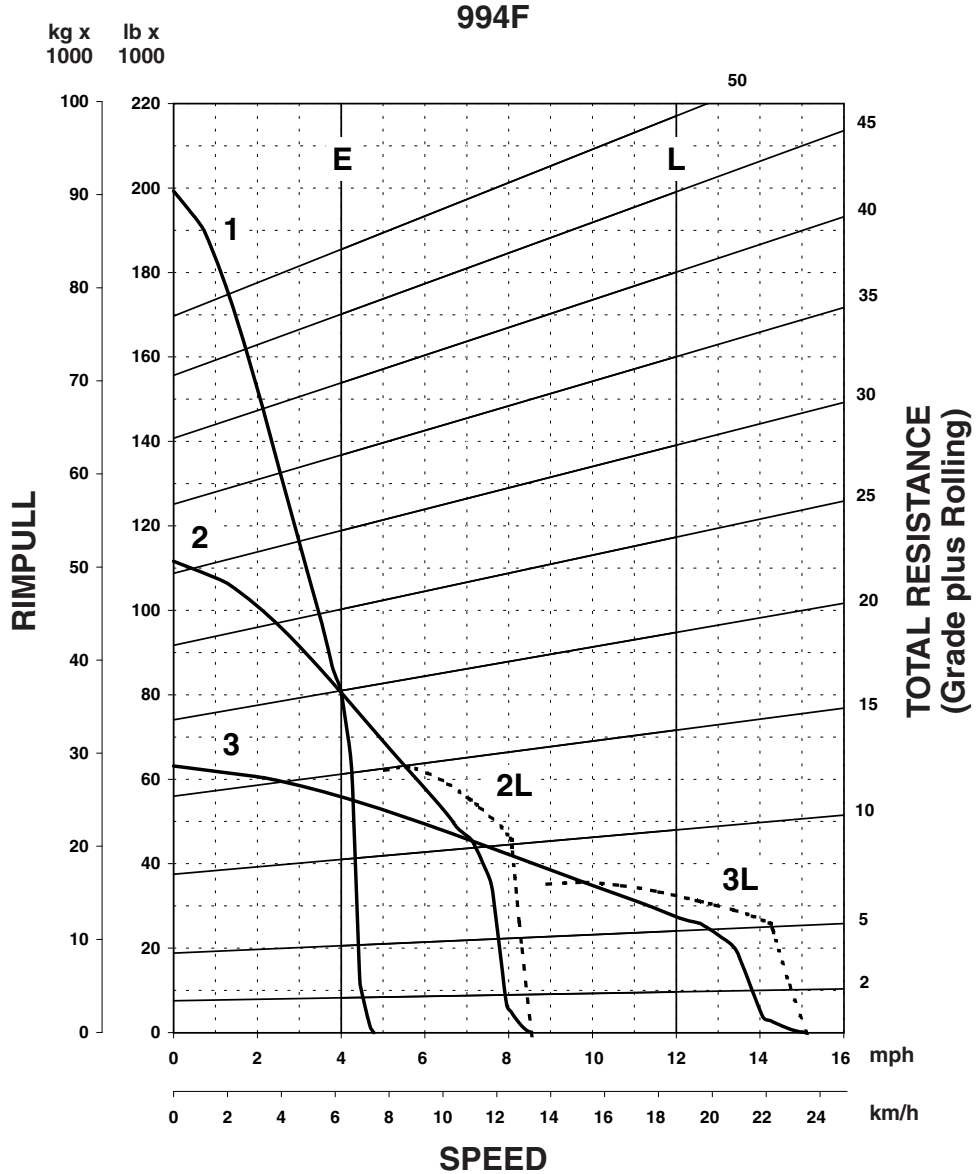

**KEY**

- 1 — 1st Gear
- 2 — 2nd Gear
- 3 — 3rd Gear

**KEY**

- E — Empty 189 345 kg (417,429 lb)
- L — Loaded 223 819 kg (493,429 lb)

Calculated Pull: Idle Hydraulics  
Curves Assume NO SLIP Conditions

**994F TRAVEL TIME — LOADED**

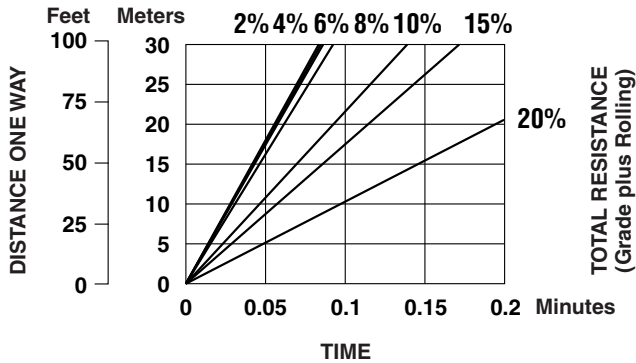
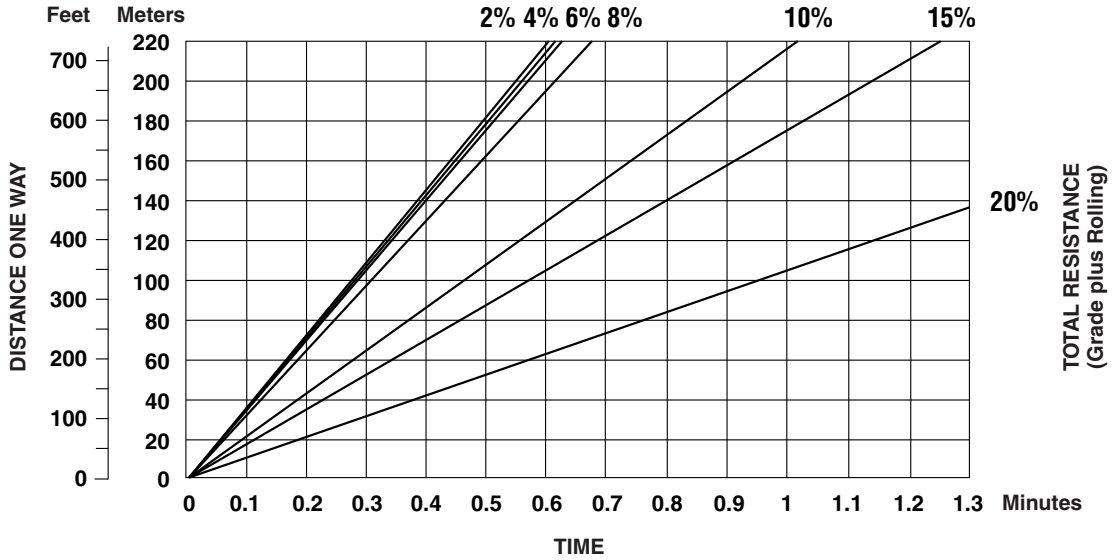

**NOTE:** Curves assume use of highest operating speed attainable: 3rd gear for 2%-10% TR, 2nd gear for 15% and 20% TR.

In load-and-carry applications it is important to consult the tire manufacturer on Ton-MPH ratings and pressure recommendations.

**994F TRAVEL TIME — EMPTY**

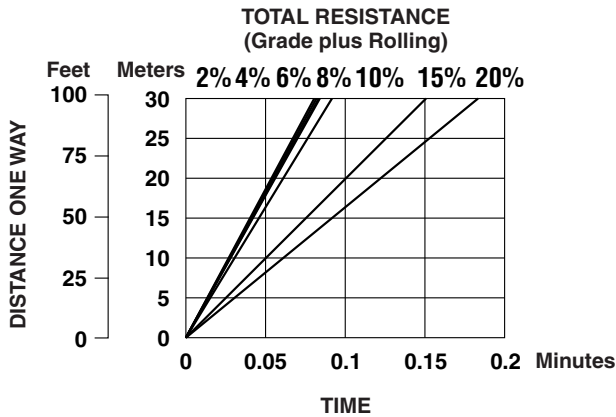
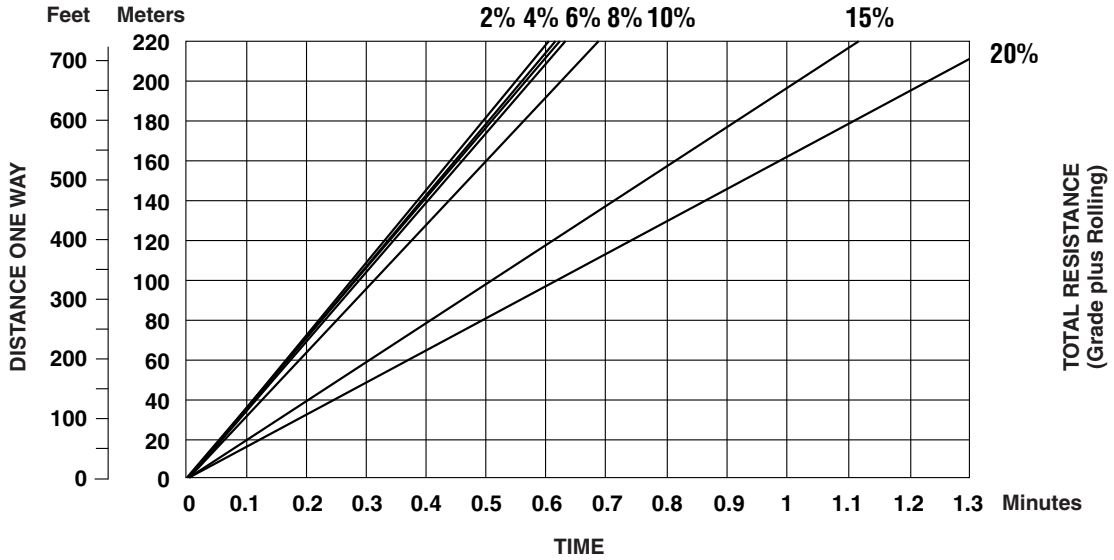

**NOTE:** Curves assume use of highest operating speed attainable: 3rd gear for 2%-10% TR, 2nd gear for 15% and 20% TR.

In load-and-carry applications it is important to consult the tire manufacturer on Ton-MPH ratings and pressure recommendations.

**994F TRAVEL TIME — LOADED**

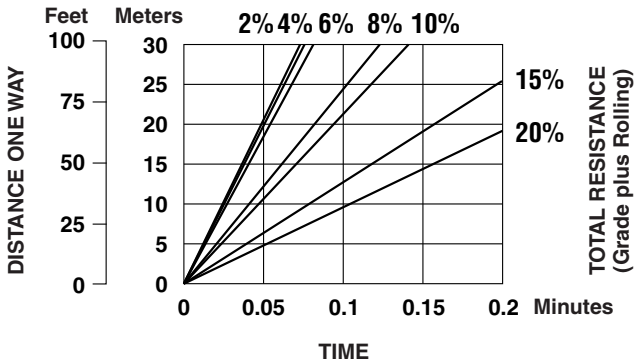
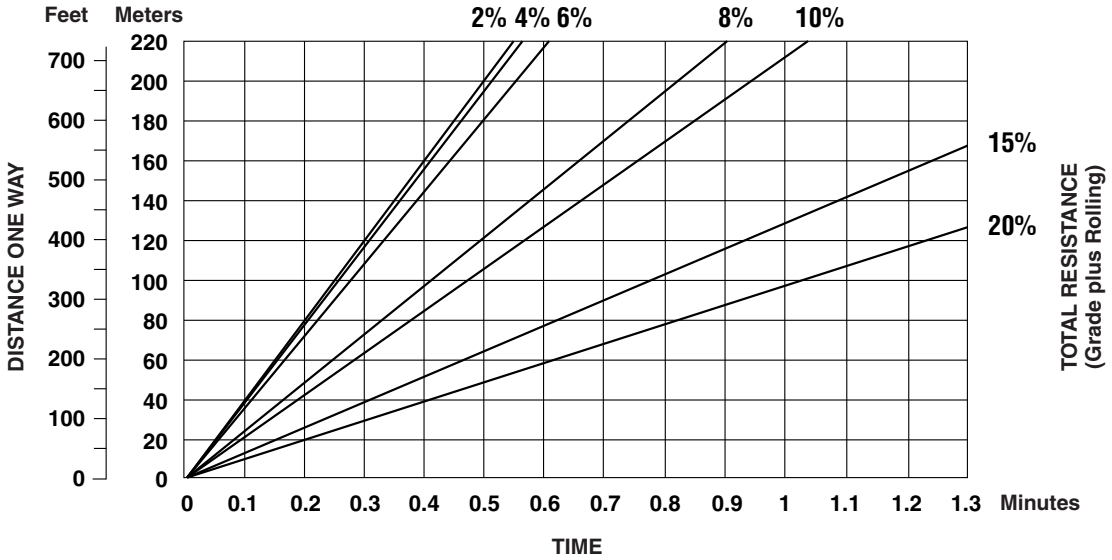

**NOTE:** Curves assume use of highest operating speed attainable: 3rd gear for 2%-8% TR, 2nd gear for 10% and 15% TR, 1st gear for 20% TR.

In load-and-carry applications it is important to consult the tire manufacturer on Ton-MPH ratings and pressure recommendations.

**994F TRAVEL TIME — EMPTY**

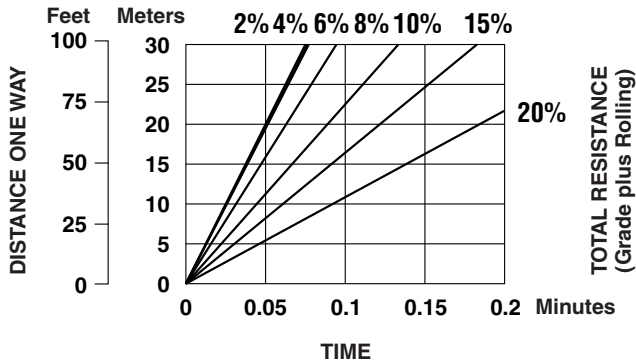
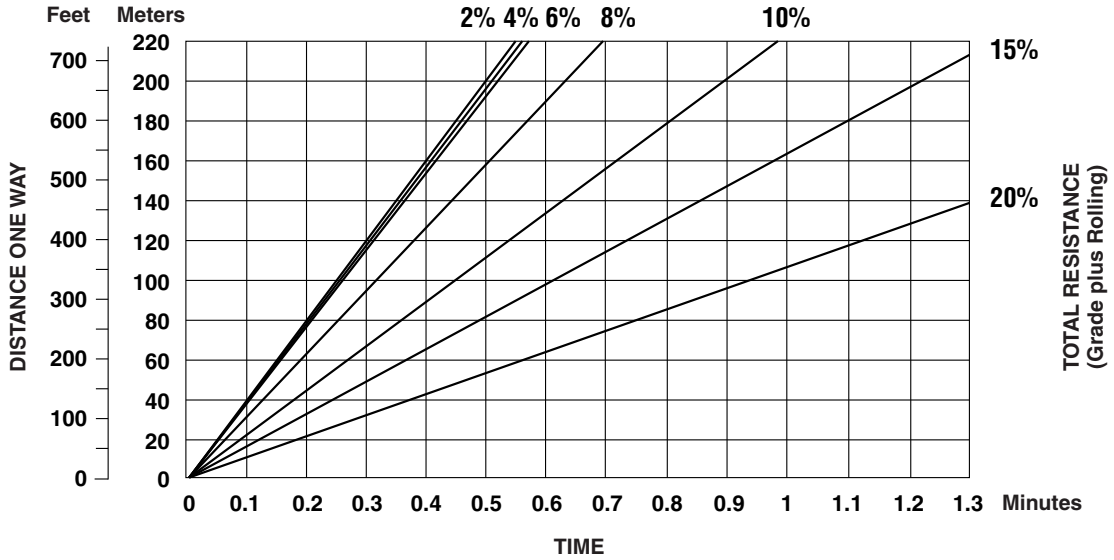

**NOTE:** Curves assume use of highest operating speed attainable: 3rd gear for 2%-10% TR, 2nd gear for 15% TR, 1st gear for 20% TR.

In load-and-carry applications it is important to consult the tire manufacturer on Ton-MPH ratings and pressure recommendations.

Production Estimating Table  
 ● m<sup>3</sup> or yd<sup>3</sup>/60 min. hour

Wheel Loaders  
 Integrated Toolcarriers

Bucket Size (m <sup>3</sup> or yd <sup>3</sup> )		1.0	1.5	2.0	2.5	3.0	3.5	4.0	4.5	5.0	5.5	6.0	6.5	7.0	7.5	8.0	8.5	9.0	9.5	10.0		
<b>Cycle Time</b>	<b>Cycles Per Hr</b>	Unshaded area indicates average production.																				
0.35	171																					
0.40	150	150	225	330	375	450	525															
0.45	133	135	200	268	332	400	466	530	600	665	730	800	865									
0.50	120	120	180	240	300	360	420	480	540	600	660	720	780	840	900	960	1003	1080	1140	1200		
0.55	109	109	164	218	272	328	382	436	490	545	600	655	705	765	820	870	925	980	1008	1090		
0.60	100	100	150	200	250	300	350	400	450	500	550	600	650	700	750	800	850	900	950	1000		
0.65	92	92	138	184	230	276	322	368	416	460	505	555	600	645	690	735	780	830	875	920		
0.70	86							342	386	430	474	515	560	600	645	690	730	775	815	860		
0.75	80												560	600	640	680	720	760	800			

Bucket Size (m <sup>3</sup> or yd <sup>3</sup> )		11.0	12.0	13.0	14.0	15.0	16.0	17.0	18.0	19.0	20.0	21.0	22.0	23.0	24.0	25.0	26.0
<b>Cycle Time</b>	<b>Cycles Per Hr</b>	Unshaded area indicates average production.															
0.35	171																
0.40	150																
0.45	133																
0.50	120	1320	1440														
0.55	109	1200	1310	1420	1520	1635	1740	1850	1960	2070	2180	2285	2395	2505	2615	2725	2830
0.60	100	1100	1200	1300	1400	1500	1600	1700	1800	1900	2000	2100	2200	2300	2400	2500	2600
0.65	92	1010	1105	1195	1285	1380	1470	1560	1655	1745	1840	1930	2020	2115	2205	2300	2390
0.70	86	945	1030	1120	1200	1290	1375	1460	1545	1630	1720	1805	1890	1975	2060	2150	2235
0.75	80	880	960	1040	1120	1200	1280	1360	1440	1520	1600	1680	1760	1840	1920	2000	2080
0.80	75			975	1050	1125	1200	1275	1350	1425	1500	1575	1650	1725	1800	1875	1950

<b>Job Efficiency</b>	<b>Efficiency</b>	<b>Bucket Load Factor</b>
<b>Worktime/Hr</b>	<b>Factor</b>	<b>Bucket Size × 1.00</b>
60 Min Hr	100%	
55	91%	.95
50	83%	.90
45	75%	.85
40	69%	.80
—	—	.75

# Wheel Loaders Integrated Toolcarriers

## Production Estimating Table

- 60 min hour
- Shot Rock
- Metric Tons

### Metric Tons ● 1600 kg Lm<sup>3</sup> (1.6 t) density

Bucket Size m <sup>3</sup>		1.0	1.5	2.0	2.5	3.0	3.5	4.0	4.5	5.0	5.5	6.0	6.5	7.0	7.5	8.0	8.5	9.0	9.5
<b>Cycle Time</b>	<b>Cycles Per Hr</b>	Unshaded area indicates average production.																	
0.40	150	240	360	480	600	720													
0.45	133	213	319	426	532	638	745	851	958	1064	1170								
0.50	120	192	288	384	480	576	672	768	864	960	1056	1152	1248	1344	1440	1536	1632	1730	1825
0.55	109	174	262	349	436	523	610	698	785	872	959	1046	1134	1221	1308	1395	1482	1570	1655
0.60	100	160	240	320	400	480	560	640	720	800	880	960	1040	1120	1200	1280	1360	1440	1520
0.65	92	147	221	294	368	442	515	589	662	736	810	883	957	1030	1104	1178	1251	1325	1400
0.70	86						482	550	619	688	757	826	894	963	1032	1101	1170	1238	1310
0.75	80											768	832	896	960	1024	1088	1150	1215
<b>Bucket Payload Metric (Tons)</b>		1.6	2.4	3.2	4.0	4.8	5.6	6.4	7.2	8.0	8.8	9.6	10.4	11.2	12.0	12.8	13.6	14.4	15.2

Bucket Size m <sup>3</sup>		10.0	11.0	12.0	13.0	14.0	15.0	16.0	17.0	18.0	19.0	20.0
<b>Cycle Time</b>	<b>Cycles Per Hr</b>	Unshaded area indicates average production.										
0.40	150											
0.45	133											
0.50	120											
0.55	109	1744	1918	2092	2267	2441	2616	2790	2964	3139	3313	3488
0.60	100	1600	1760	1920	2080	2240	2400	2560	2720	2880	3040	3200
0.65	92	1472	1619	1766	1913	2060	2208	2355	2502	2649	2796	2944
0.70	86	1376	1513	1651	1788	1926	2064	2201	2339	2476	2614	2752
0.75	80	1280	1408	1536	1664	1792	1920	2048	2176	2304	2432	2560
0.80	75	1200	1320	1440	1560	1680	1800	1920	2040	2160	2280	2400
<b>Bucket Payload Metric (Tons)</b>		16.0	17.6	19.2	20.8	22.4	24.0	25.6	27.2	28.8	30.4	32.0

**U.S. Tons ● 2700 lb/LCY (1.35 T) density**

Bucket Size yd <sup>3</sup>		1.0	1.5	2.0	2.5	3.0	3.5	4.0	4.5	5.0	5.5	6.0	6.5	7.0	7.5	8.0	8.5	9.0	9.5	10.0
Cycle Time	Cycles Per Hr	Unshaded area indicates average production.																		
		0.40	150	203	330	420	510	615	705	810										
0.45	133	180	293	360	454	545	625	720	810	905	985	1080	1170							
0.50	120	162	254	324	408	492	565	650	730	815	890	970	1060	1140	1200	1300	1380	1470	1540	1620
0.55	109	147	240	294	370	448	515	590	665	740	805	885	960	1030	1090	1180	1250	1330	1400	1740
0.60	100	135	220	270	340	410	470	540	610	680	740	810	880	950	1000	1080	1150	1220	1280	1350
0.65	92	124	200	250	314	380	435	500	560	625	680	750	810	875	920	985	1060	1120	1180	1250
0.70	86								525	585	635	695	755	815	860	930	990	1050	1100	1160
0.75	80													760	800	865	920	975	1030	1080
Bucket Payload (Tons)		1.35	2.2	2.7	3.4	4.1	4.7	5.4	6.1	6.8	7.4	8.1	8.8	9.5	10.0	10.8	11.5	12.2	12.8	13.5

Bucket Size yd <sup>3</sup>		11.0	12.0	13.0	14.0	15.0	16.0	17.0	18.0	19.0	20.0	21.0	22.0	23.0	24.0	25.0	26.0
Cycle Time	Cycles Per Hr	Unshaded area indicates average production.															
		0.40	150														
0.45	133																
0.50	120	1782	1945														
0.55	109	1620	1765	1905	2060	2200	2350	2495	2645	2790	2940	3080	3235	3375	3530	3670	3825
0.60	100	1485	1620	1750	1890	2020	2160	2290	2430	2560	2700	2830	2970	3100	3240	3370	3510
0.65	92	1365	1490	1610	1735	1855	1985	2105	2235	2355	2480	2600	2730	2850	2980	3100	3225
0.70	86	1275	1390	1505	1625	1735	1855	1965	2085	2200	2320	2430	2550	2665	2785	2895	3015
0.75	80	1190	1295	1400	1510	1615	1725	1830	1940	2045	2160	2260	2375	2480	2590	2695	2805
0.80	75			1310	1415	1515	1620	1715	1820	1920	2025	2120	2225	2325	2430	2525	2630
Bucket Payload (Tons)		14.9	16.4	17.5	18.9	20.2	21.6	22.9	24.3	25.6	27.0	28.3	29.7	31.0	32.4	33.7	35.1



Work Tools	994F	993K	992K	990H	988H	980H	972H	966H	962H	950H	938H	928H	924H	914G	908H, 907H, 906H†	908H, 907H, 906H††	904H
Quick coupler				X	X	X								X	X	X	X
Fusion Quick Coupler							X	X	X	X	X	X	X				
Performance Series general purpose bucket					X	X	X										
General purpose bucket				X	X	X	X	X	X	X	X	X	X	X	X	X	X
Coal bucket	X	X	X	X	X	X	X	X	X	X	X	X	X	X			
Woodchip bucket					X	X	X	X	X	X	X	X	X	X			
Refuse bucket						X	X	X	X	X	X	X	X				
Material handling bucket				X	X	X	X	X	X	X	X	X	X	X	X		X
Sand & gravel bucket					X	X	X	X	X	X							
Rock bucket	X	X	X	X	X	X	X	X	X	X							
Slag bucket				X	X	X											
Bonus bucket					X	X											
Multi-purpose bucket							X	X	X	X	X	X	X	X	X	X	X
Side dump bucket							X	X	X	X	X	X	X	X			
Bucket with top clamp						X	X	X	X	X	X	X	X	X			
Material handling arm						X	X	X	X	X	X	X	X	X	X	X	X
Pallet fork					X	X	X	X	X	X	X	X	X	X	X		X
Millyard fork					X	X	X	X	X	X	X	X	X				
Log/lumber fork						X	X	X	X	X	X	X	X	X			
Logging fork				X	X	X	X	X	X	X							
Core fork							X	X	X	X		X					
V-plow									X	X	X	X	X	X			
Manual reverse plow							X	X	X	X	X	X	X	X			
Hydraulic reverse plow							X	X	X	X	X	X	X	X			
Loader rake							X	X	X	X	X	X	X	X			
Hydraulic angle broom									X	X	X	X*	X*	X	X		X
Block handling bucket					X	X											
Block handling fork					X	X											
Breaker tine					X	X											
Boom clearing rake					X	X											
Stone sieve bucket										X							
High dump bucket							X	X	X	X	X	X	X	X			
Pickup sweeper													X*	X*			X

\*Requires IT compatible quick coupler.

†Vertical coupler.

††Horizontal coupler.

**NOTE:** List is not all-inclusive. Contact your Cat dealer for special attachment needs.

**BUCKETS**

**Performance Series** — optimized fill factors for use in truck loading, stockpiling and load-and-carry applications.

**General Purpose** — for most material types with choice of cutting edges and teeth.

**Loose Material** — designed for snow, woodchips, hay, coal, etc. Add independently controlled top clamp for materials like hay, brush, silage or compost.

**Multi-purpose** — versatile ... loads, strips top-soil, bulldozes, clamps pipe, cleans up debris, plus many other tasks.

**High dump or “roll-out”** — for extended dump height of light materials.

**Side dump** — dump forward or to the left ... ideal in close quarters or to reduce turning time.

**Grading** — long, flat floor and straight edge for finish work in housing developments, concrete pours, landscaping and light dozing.

**FORKS**

**Log or lumber forks** — with optional clamps, single, double or full-width.

**Wide frame forks** — adjustable for control of long pipes, culverts, etc.

**Stinger fork** — with long single shaft to penetrate salvage autos or round hay bales.

**Utility pallet forks** — for a variety of tasks, with three different tine sizes.

**Pulpwood** — choice of single or double top clamp for positive control of material.

**Sorting** — designed for durability and efficiency in stacking operations.

**BLADES**

**Angling dozer** — choice of manual or hydraulic angling 25° left or right.

**Straight blade** — for spreading, leveling and other utility dozing.

**One-way snow blade** — economical snow clearing with minimal machine effort.

**V-plow** — excellent for breaking up large drifts or high speed clearing operations.

**Material Handling arm** — carries and places pipe, prefabricated building panels and handles bulky, nonpalletized material ... two telescopic sections extend for three position operation.

**AND MORE ...**

**Rotary broom** — for street cleanup, snow removal, jobsite clean-up, clearing runways ... angles left or right 30°.

**Asphalt cutter** — aids repair work on roads, pavements, water and sewer mains ... cuts clean to 125 mm (5").

**Hooks** — for attachment to dumpsters, bins, troughs, etc., to permit quick, easy, instant movement from place to place.

These products are available through your Cat dealer.

**Integrated Toolcarriers Work Tools**

Work Tools	IT62H	IT38H	930H	924H	IT14G
Bucket with Top Clamp	X	X	X	X	X
Multi-Purpose Bucket	X	X	X	X	X
Side Dump Bucket	X	X	X	X	X
High Dump Bucket	X	X	X	X	X
MH Bucket	X	X	X	X	X
Clean-up Bucket	X				
Pallet Fork	X	X	X	X	X
Log/Lumber Fork	X	X	X	X	X
Core Fork			X	X	X
Straight Blade			X	X	X
Manual Angle Blade	X	X	X	X	X
Hydraulic Angle Blade			X	X	X
Manual Reversible Plow	X	X	X	X	X
Hydr. Reversible Plow	X	X	X	X	X
V-Plow			X	X	X
One Way Plow			X	X	X
Asphalt Cutter			X	X	X
Hydraulic Angle Broom	X	X	X	X	X
Pick-up Broom			X	X	X
Hydraulic Hammers			X	X	X
Loader Rake	X	X	X	X	X
Woodchip	X	X	X	X	X
Refuse	X	X	X	X	X
Millyard Fork	X	X			
Logging Fork	X	X			
Grapple	X	X			

This list not all inclusive. Contact your Cat dealer for special attachment needs.

## **FUSION™ COUPLER SYSTEM**

Caterpillar is breaking new ground with the Fusion™ Coupler System. Caterpillar engineers designed this new system to exceed the performance of any other Cat or competitive coupler solution in the marketplace. This coupler system is a factory- or field-installed option for Cat Loaders from 924H/G through 972H/G, including IT38 and IT62 machines. Fusion offers benefits in four main categories:

### **Performance**

This new, patented interface provides coupler flexibility with performance virtually identical to pin-on.

Imagine lifting a hundred-pound box with your arms fully extended. Now, imagine lifting that same load close to your body. That's the genius of Fusion: designed to integrate the work tool and the machine by pulling the coupler and tool closer to the wheel loader. As a result, the center of gravity is moved inward, towards the machine. This translates to increased lifting ability when compared to machines equipped with competing coupler systems.

### **Durability**

The advanced wedging mechanism of the Fusion™ Coupler creates a tight, rattle-free fit. This new lock up system eliminates play and wear — resulting in a long service life.

Wedges pull the attachment tight to the machine in two directions — in and down. Constant hydraulic pressure on the coupler wedges compensate for wear, assuring a tight fit throughout the life of the coupler. Tight fit gives better tool control and increased productivity. Plus, coupler durability is substantially increased over traditional couplers.

### **Visibility**

A new, open coupler frame design opens sight lines from the operator's seat, making it easier than ever before to engage and disengage attachments with certainty.

Offset tines and other design changes to Fusion Pallet Forks, working in conjunction with the Fusion Coupler, increase visibility substantially at ground level and truck bed height when compared to traditional coupler and fork combinations.

### **Flexibility/Compatibility**

With the Fusion Coupler system, Caterpillar customers get **one common interface**. This unique, single interface eliminates the need for many different couplers across the entire range of Cat Small and Medium Wheel Loaders. This expanded machine compatibility not only allows one machine to pick up a range of work tools, but also for one work tool to be used by a host of different machines. Realize the flexibility and opportunity afforded your rental operation, or the improvements to machine and work tool management on your customers' job sites.

Fusion is supported by a full line of work tools. Just about any work tool available for pin-on is also available, or can be converted, to work with Fusion. For complete information, visit <https://fusion.cat.com>

**Fusion Work Tools**

	924H/G, 924Hz/Gz	930H/G	928H/G	IT38H/G	938H/G	IT62H/G	950H/G	962H/G	966H/G	972H/G
GP Bucket	X	X	X	X	X	X	X	X	X	X
Grapple Bucket	X	X	X	X	X	X	X	X	X	
Coal/Light Material Bucket				X	X	X	X	X	X	X
High Dump Bucket	X	X	X	X	X	X	X	X	X	
Material Handling Bucket	X	X	X	X	X	X	X	X	X	X
Multi-Purpose Bucket	X	X	X	X	X	X	X	X	X	
Spade Rock Bucket							X	X	X	X
Side Dump Bucket	X	X	X	X	X	X	X	X	X	
Woodchip/Cleanup Bucket	X	X	X	X	X	X	X	X	X	X
Waste Bucket	X	X	X	X	X	X	X	X	X	X
Pickup Broom	X	X	X	X	X	X	X	X		
Angle Broom	X	X	X	X	X	X	X	X		
Pallet Fork	X	X	X	X	X	X	X	X	X	X
Log and Lumber Fork	X	X	X	X	X	X	X	X	X	X
Rakes	X	X	X	X	X	X	X	X	X	X
Top Clamp Rakes	X	X	X	X	X	X	X	X		
Material Handling Arms	X	X	X	X	X	X	X	X	X	X
Plow	X	X	X	X	X	X	X	X	X	X
V-Plow							X	X	X	X

See Product Bulletin GEJQ0222 for complete Fusion Work Tool information.



# TRACK LOADERS

## CONTENTS

Features . . . . .	13-1
Specifications . . . . .	13-4
Performance Data . . . . .	13-6
Machine Dimensions with General Purpose Bucket . . . . .	13-15
Machine Dimensions with Multi-Purpose Bucket . . . . .	13-16
Rippers/Scarifiers . . . . .	13-17
Drawbar Curves . . . . .	13-19
SAE Loader Ratings . . . . .	13-20
Estimating Cycle Time . . . . .	13-21
Bucket Fill Factors . . . . .	13-22
Recommended Operating Capacities . . . . .	13-22
Loader Production . . . . .	13-22
Estimating Bucket Load . . . . .	13-22
Estimating Production . . . . .	13-23
Alternative Machine Selection Method . . . . .	13-23
Production and Machine Selection: Nomographs . . . . .	13-24
Travel Time Charts . . . . .	13-26
Production Estimating Table . . . . .	13-28
Waste Handling Track Loaders . . . . .	See Section 25
Work Tools . . . . .	13-29

## Features of 939C:

- **Hydrostatic drive train** offers infinitely variable speeds, fast acceleration, dynamic hydrostatic braking, superior maneuverability and excellent controllability.

## Features common to all D Series models (953D-963D-973D):

- **Improved serviceability.** All D Series Track-Type Loaders are equipped with a tiltable cab that allows complete service of the hydraulic system. Most daily maintenance checks are performed from the machine's right side, facilitating quick start up. Easy access to major components enhances serviceability and increase uptime.
- **Operator station.** Experience a high level of efficiency, comfort and productivity with the new D Series cab. The cab features a new gauge cluster, a fully air-suspension seat, the new seat mounted controls, an automatic air climate control and provides excellent visibility.
- **Messenger.** Messenger is a new electronic monitoring system with real time, visual feedback on engine and machine operating conditions. It provides information on diagnostic data, maintenance, and allows operating settings such as implement reactions.
- **Hydrostatic drive.** The closed loop hydrostatic drive with electronic control provides precise modulation for quick, smooth operation and superior maneuverability. Shorter cycle times, high efficiency, and excellent maneuverability results in increased productivity.

**Features common to all D Series models (953D-963D-973D) (continued):**

- **Steering controls.** All D Series Track Loaders are offered with a choice of either the traditional V-lever with pedal steering or joystick control. With joystick control both steering and transmission functions are managed using the joystick. The joystick handles includes three buttons. The yellow buttons are used to increase/decrease the travel speed of the machine. The black button activates the horn. There are four different settings for both forward and reverse with the speed displayed on the multifunctional dashboard. This pattern is commonly referred to as S-pattern steering. All Cat® D Series Track-Type Loaders (953D – 963D – 973D) provide the option of two different transmission control joystick configurations. All machines ship from the factory with the default S-Pattern like a Cat Skid Steer Loader. After the machine arrives at the dealership, it can be changed to C-Pattern by the Cat Electronic Technician service tool if required.
- **Electro-hydraulic implements controls.** The new electro hydraulic implement controls provide the operator with responsive, smooth and precise control of bucket and lift arms.
- **Kickout settings.** Automatic kickouts are part of the electro-hydraulic controls; adjust from inside the cab with a simple rocker switch. Kickout stops are hydraulically cushioned for greater operator comfort and less material spillage.
- **Position Sensing Cylinder.** The D Series has electro-hydraulic implement controls for lower operator effort. The new position sensing cylinders allow setting detents at any positions from the cab. They feature also a load sensing implement pump which reduces engine power consumption.
- **Hydraulic on-demand fan.** The fan is a hydraulic demand type one with optional reversible function, operating in sucker mode. It gives the best efficiency and avoids also sucking the dust and debris coming from the outside into the cooling package.
- **Oscillating track roller frames** decrease ground shock, increase machine stability and improve traction.
- **Unmatched versatility** — excavates, loads, dozes, grades, clears, strips, backfills in all underfoot conditions including those that could damage tires.
- **Sound-suppressed, air-pressurized, resiliently mounted ROPS cab** for superior working environment.
- **Sealed loader linkage** extends lubrication intervals and reduces maintenance time.
- **Automatic bucket controls** let bucket rise to pre-set dumping height and return to pre-set digging angle for fast cycle time.
- **General Purpose and Multi-Purpose** buckets, quick couplers and many other work tools are available to increase versatility.
- **Rippers** are Multishank with wide beam coverage for utility ripping close to walls, footings and embankments. Three shanks are available for D Series Track Loaders.
- **Product Link System** reports machine location and hours and consequently makes the maintenance easier and reduces the downtime. Please check availability with your local dealer.
- **Cat® Machine Security System** allows better machine protection by preventing theft. A microchip is embedded in the key to provide more security. Cat Machine Security System is an optional feature.
- **K System** is a Caterpillar exclusive which allows ease of installation and removal. New adapters provide better performance and offer a longer lasting life than J Series (+30%).
- **Special Application Arrangements.** Special arrangements — Waste Handling, Demolition, Wide Gauge and more, are available or can be designed on request, to allow the D Series to work in special applications.

**Features of 953D-963D:**

- **C6.6 ACERT Engine.** The Cat C6.6 ACERT engine utilizes the Cat Common Rail fuel delivery system. Designed for performance, durability, serviceability, and fuel economy, it meets EPA Tier 3, EU Stage IIIA and Japan Ministry of Land, Infrastructure & Transport Step 3 emission standards.
- **SystemOne Moving U/C.** The revolutionary Cat SystemOne™ Undercarriage provides maximum undercarriage life and reliability no matter the application, environment or underfoot conditions. Built to last longer and require less maintenance it ensures a dramatic drop in owning and operating costs.
- **Special Application Arrangements.** Ship Hold Arrangements are available on 953D-963D.

**Features of 973D:**

- **C9 ACERT Engine.** The Cat® C9 ACERT engine is an 8.8 liter (537 in<sup>3</sup>) displacement, six-cylinder, in-line configured engine with hydraulically actuated electronic fuel injection or HEUI™. The 196 kW (263 hp) rated net power engine meets the U.S. EPA Tier 3, European Union Stage IIIA and Japan MOC exhaust emission regulations.
- **Rear engine location** provides natural stability as a “working” counterweight, excellent visibility and good weight to horsepower ratio.
- **Electronic hydrostatic drive train with pedal steering** offers independent control of each track. Power turns, counterrotation infinitely variable speeds, and fast acceleration for increased maneuverability and production.
- **Variable displacement pump and motors** provide excellent efficiency and controllability.
- **Z-bar linkage** provides increased breakout force, fewer grease points and fast dump speed.
- **Special arrangements** including Wide Gauge, Waste Handling, Ship Hold, Tunneling and Steel Mill are available to tailor the machine to specific applications.
- **Special Application Arrangements.** The steel mill arrangement protects the 973D and its operator against extreme conditions to allow the machine to handle hot slag in steel mill operations. The special arrangement features additional guarding for critical components, sealed undercarriage, heat shields for fuel tank, power train and hydraulics, silicone seals and heat resistant windshield, remote parking brake release and fire-resistant fluids. The Steel Mill Arrangement provides the best protection available for this extremely difficult application.





MODEL	939C		953D		963D	
Flywheel Power	67.1 kW	<b>90 hp</b>	110 kW	<b>148 hp</b>	141 kW	<b>189 hp</b>
Operating Weight*	9480 kg	<b>20,900 lb</b>	15 517 kg	<b>34,209 lb</b>	20 220 kg	<b>44,577 lb</b>
Engine Model	<b>3046 T</b>		<b>C6.6 ACERT</b>		<b>C6.6 ACERT</b>	
Rated Engine RPM	<b>2400</b>		<b>2000</b>		<b>2000</b>	
Bore	94 mm	<b>3.7"</b>	105 mm	<b>4"</b>	105 mm	<b>4.13"</b>
Stroke	120 mm	<b>4.7"</b>	127 mm	<b>5"</b>	127 mm	<b>5"</b>
No. Cylinders	<b>6</b>		<b>6</b>		<b>6</b>	
Displacement	5 L	<b>305 in<sup>3</sup></b>	6.6 L	<b>402.7 in<sup>3</sup></b>	6.6 L	<b>402.7 in<sup>3</sup></b>
Speeds Forward/Reverse	0-9 km/h	<b>0-5.6 mph</b>	km/h	<b>mph</b>	km/h	<b>mph</b>
1st	—		0-10	<b>0-6.2</b>	0-10	<b>0-6.2</b>
2nd	—		<b>Infinitely</b>		<b>Infinitely</b>	
3rd	—		<b>Variable</b>		<b>Variable</b>	
Hydraulic Cycle Time, Bucket Empty, in Seconds:						
Raise	<b>5.6</b>		<b>5.9</b>		<b>5.8</b>	
Dump	<b>2.4</b>		<b>1.5</b>		<b>1.3</b>	
Lower (Empty, Float Down)	<b>2.9</b>		<b>3.2</b>		<b>2.9</b>	
Total	<b>10.9</b>		<b>10.6</b>		<b>10.0</b>	
Track Rollers (Each Side)	<b>6</b>		<b>6</b>		<b>7</b>	
Width of Standard Track Shoe	406 mm	<b>16"</b>	480 mm	<b>19"</b>	550 mm	<b>21.6"</b>
Length of Track on Ground	2140 mm	<b>84.4"</b>	2323 mm	<b>91.4"</b>	2543 mm	<b>100.1"</b>
Ground Contact Area (with Standard Shoes)	1.74 m <sup>2</sup>	<b>2700 in<sup>2</sup></b>	2.3 m <sup>2</sup>	<b>3565 in<sup>2</sup></b>	2.8 m <sup>2</sup>	<b>4340 in<sup>2</sup></b>
Ground Pressure	53.7 kPa	<b>7.8 psi</b>	65.5 kPa	<b>9.5 psi</b>	71.5 kPa	<b>10.3 psi</b>
Ground Clearance	369 mm	<b>14.5"</b>	416 mm	<b>16.3"</b>	471 mm	<b>18.5"</b>
Track Gauge	1550 mm	<b>61"</b>	1800 mm	<b>71"</b>	1850 mm	<b>72.8"</b>
Width without Bucket (with Standard Shoes)	1960 mm	<b>77"</b>	2280 mm	<b>89.7"</b>	2400 mm	<b>94.5"</b>
Fuel Tank Refill Capacity	157 L	<b>41.4 U.S. gal</b>	316 L	<b>83.5 U.S. gal</b>	400 L	<b>105.6 U.S. gal</b>
Hydraulic System Refill Capacity	56.8 L	<b>15 U.S. gal</b>	70 L	<b>18.5 U.S. gal</b>	90 L	<b>23.8 U.S. gal</b>

\*939C weights include basic machine (General Arrangement Number), lubricants, coolants, full fuel tank, operator, general purpose bucket and bucket teeth and OROPS. 953D and 963D include GP bucket with bolt-on adapters, long tips and segments.



MODEL	973C		973D	
Flywheel Power	178 kW	239 hp	196 kW	263 hp
Operating Weight*	26 373 kg	58,142 lb	28 058 kg	61,857 lb
Engine Model	C9 ACERT		C9 ACERT	
Rated Engine RPM	2000		1900	
Bore	112 mm	4.41"	112 mm	4.41"
Stroke	149 mm	5.87"	149 mm	5.87"
No. Cylinders	6		6	
Displacement	8.8 L	537 in <sup>3</sup>	8.8 L	537 in <sup>3</sup>
Speeds Forward/Reverse	km/h	mph	km/h	mph
1st	0-10	0-6.2	0-11	0-6.8
2nd	Infinitely		Infinitely	
3rd	Variable		Variable	
Hydraulic Cycle Time, Bucket Empty, in Seconds:				
Raise	6.7		6.5	
Dump	1.5		1.4	
Lower (Empty, Float Down)	2.9		2.7	
Total	11.1		10.6	
Track Rollers (Each Side)	7		7	
Width of Standard Track Shoe	500 mm	19.7"	550 mm	21.7"
Length of Track on Ground	2930 mm	115"	2930 mm	115"
Ground Contact Area (with Standard Shoes)	2.93 m <sup>2</sup>	4542 in <sup>2</sup>	3.22 m <sup>2</sup>	4991 in <sup>2</sup>
Ground Pressure	91.2 kPa	13.2 psi	85.5 kPa	12.0 psi
Ground Clearance	457 mm	17.9"	482 mm	18.98"
Track Gauge	2080 mm	82"	2160 mm	85"
Width without Bucket (with Standard Shoes)	2580 mm	102"	2710 mm	106.7"
Fuel Tank Refill Capacity	430 L	113 U.S. gal	621 L**	164.1 U.S. gal**
Hydraulic System Refill Capacity	62 L	16.4 U.S. gal	189 L	49.9 U.S. gal

\*973C includes GP bucket with bolt-on adapters, long tips and segments.

\*\*Except for Steel Mill Arrangement — Fuel Tank Refill Capacity is 422 L (111.4 U.S. gal).

BUCKET	General Purpose		Multi-Purpose	
Capacity, Rated (Nominal Heaped)	1.15 m <sup>3</sup>	<b>1.5 yd<sup>3</sup></b>	1.15 m <sup>3</sup>	<b>1.5 yd<sup>3</sup></b>
Struck	0.95 m <sup>3</sup>	<b>1.25 yd<sup>3</sup></b>	0.95 m <sup>3</sup>	<b>1.25 yd<sup>3</sup></b>
Bucket Width*	2160 mm	<b>7'1"</b>	2160 mm	<b>7'1"</b>
Dump Clearance at Full Lift and 45° Discharge	2667 mm	<b>8'9"</b>	2604 mm	<b>8'6.5"</b>
Maximum Reach at Full Lift and 45° Discharge	866 mm	<b>2'10.1"</b>	877 mm	<b>2'10.5"</b>
Digging Depth	127 mm	<b>5"</b>	165 mm	<b>6.5"</b>
Overall Length	4359 mm	<b>14'3.6"</b>	4359 mm	<b>14'4"</b>
Overall Height	4384 mm	<b>14'4.6"</b>	4384 mm	<b>14'4.6"</b>
Static Tipping Load	6607 kg	<b>14,560 lb</b>	6396 kg	<b>14,100 lb</b>
Breakout Force**	89.9 kN	<b>20,200 lb</b>	92 kN	<b>20,690 lb</b>
Operating Weight***	9484 kg	<b>20,910 lb</b>	10 030 kg	<b>22,110 lb</b>

\*Bolt-on teeth increase bucket width by 42 mm (1.65"). Bolt-on cutting edge increases bucket width by 10 mm (0.39").

\*\*Breakout force is measured 102 mm (4") behind tip of cutting edge with bucket hinge pin as pivot point.

\*\*\*Operating weight includes coolant, lubricants, full fuel tank, bottom guards (STD), bucket teeth, ROPS canopy and operator. 454 kg (1000 lb) rear counterweight is also removed while using Multi-Purpose bucket.

Machine stability can be affected by the addition of other attachments. Add or subtract the following to/from machine operating weight and static tipping load:

	Change in Operating Weight		Change in Static Tipping Load	
	kg	lb	kg	lb
Cab, ROPS	+204	<b>+450</b>	+266	<b>+586</b>
Bucket teeth (long) & segments	+118	<b>+260</b>	-150	<b>-330</b>
Air Conditioner	+ 77	<b>+170</b>	+ 88	<b>+194</b>
Ripper with 3 teeth (includes removal of 295 kg (650 lb) rear counterweight)	+ 17	<b>+ 37</b>	+ 49	<b>+108</b>
Rear counterweight (per plate)	+115	<b>+255</b>	+203	<b>+448</b>

BUCKET	General Purpose Bare		General Purpose Bolt-on Adapters, Long Teeth & Segments		General Purpose Bolt-on Cutting Edge		General Purpose Flush Weld-on Adapters & Long Teeth	
	Capacity, Rated (Nominal Heaped) Struck	1.75 m <sup>3</sup>	<b>2.29 yd<sup>3</sup></b>	1.85 m <sup>3</sup>	<b>2.42 yd<sup>3</sup></b>	1.85 m <sup>3</sup>	<b>2.42 yd<sup>3</sup></b>	1.85 m <sup>3</sup>
Cutting Edge, Type	1.45 m <sup>3</sup>	<b>1.90 yd<sup>3</sup></b>	1.55 m <sup>3</sup>	<b>2.03 yd<sup>3</sup></b>	1.55 m <sup>3</sup>	<b>2.03 yd<sup>3</sup></b>	1.45 m <sup>3</sup>	<b>1.90 yd<sup>3</sup></b>
Bucket Width◀	<b>Straight</b>		<b>Straight</b>		<b>Straight</b>		—	
Teeth	2392 mm	<b>94.2"</b>	2485 mm	<b>97.8"</b>	2395 mm	<b>94.3"</b>	2438 mm	<b>96"</b>
	<b>None</b>		<b>8, bolt-on plus replaceable tips</b>		<b>None</b>		<b>8, bolt-on plus replaceable tips</b>	
Dump Clearance @ Full Lift and 45° Discharge	2855 mm	<b>112.4"</b>	2616 mm	<b>102.9"</b>	2786 mm	<b>109.6"</b>	2659 mm	<b>104.7"</b>
Reach at 45° Discharge Angle 2133 mm (7'0") Clearance	1550 mm	<b>61"</b>	1630 mm	<b>64.2"</b>	1559 mm	<b>61.4"</b>	1656 mm	<b>65.2"</b>
Reach @ Full Lift and 45° Discharge	928 mm	<b>36.5"</b>	1099 mm	<b>43.3"</b>	961 mm	<b>37.8"</b>	1104 mm	<b>43.5"</b>
Digging Depth	92 mm	<b>3.6"</b>	140 mm	<b>5.5"</b>	117 mm	<b>4.6"</b>	105 mm	<b>4.1"</b>
Ground Clearance from Face of Shoes	416 mm	<b>16.3"</b>	416 mm	<b>16.3"</b>	416 mm	<b>16.3"</b>	416 mm	<b>16.3"</b>
Overall Machine Width without Bucket (with Standard Track) 480 mm (19")	2280 mm	<b>89.7"</b>	2280 mm	<b>89.7"</b>	2280 mm	<b>89.7"</b>	2280 mm	<b>89.7"</b>
Overall Machine Width without Bucket (with Narrow Track) 380 mm (15")	2180 mm	<b>85.8"</b>	2180 mm	<b>85.8"</b>	2180 mm	<b>85.8"</b>	2180 mm	<b>85.8"</b>
Overall Length	5926 mm	<b>233.3"</b>	6252 mm	<b>246.1"</b>	6017 mm	<b>236.9"</b>	6198 mm	<b>244"</b>
Overall Height	3105 mm	<b>122.2"</b>	3105 mm	<b>122.2"</b>	3105 mm	<b>122.2"</b>	3105 mm	<b>122.2"</b>
Static Tipping Load	11 431 kg	<b>25,201 lb</b>	11 089 kg	<b>24,447 lb</b>	11 252 kg	<b>24,806 lb</b>	11 255 kg	<b>24,813 lb</b>
Breakout Force*	160.5 kN	<b>36,092 lb</b>	157.8 kN	<b>35,491 lb</b>	159.3 kN	<b>35,828 lb</b>	162.5 kN	<b>36,549 lb</b>
Operating Weight**	15 517 kg	<b>34,209 lb</b>	15 758 kg	<b>34,740 lb</b>	15 638 kg	<b>34,475 lb</b>	15 635 kg	<b>34,469 lb</b>

\* Breakout force is measured 100 mm (3.94") behind tip of cutting edge with bucket hinge pin as pivot point.

\*\* Operating weight includes coolant, lubricants, full fuel tank, ROPS cab, bucket, and 75 kg (165 lb) operator.

◀ Bolt-on teeth increase bucket width by 52 mm (2"). Bolt-on cutting edge increases bucket width by 17 mm (0.67").

Machine stability can be affected by the addition of other attachments. Add or subtract the following to/from machine operating weight and static tipping load:

	Change in Operating Weight		Change in Static Tipping Load for General Purpose Bucket	
	kg	lb	kg	lb
Ripper (includes ripper, rear lines, and third valves) . . . . .	+461	<b>+1016</b>	+967	<b>+2131</b>
Air conditioner . . . . .	<b>Standard</b>		<b>Standard</b>	
Wide track shoes, 480 mm (19") double grouser . . . . .	-588	<b>-1296</b>	-405	<b>- 892</b>
Rear bumper (removal) . . . . .	-185	<b>- 408</b>	-411	<b>- 906</b>

BUCKET	Multi-Purpose Bare		Multi-Purpose Bolt-on Adapters, Long Tips & Segments		Multi-Purpose Bolt-on Cutting Edge	
Capacity, Rated (Nominal Heaped)	1.5 m <sup>3</sup>	<b>1.96 yd<sup>3</sup></b>	1.6 m <sup>3</sup>	<b>2.09 yd<sup>3</sup></b>	1.6 m <sup>3</sup>	<b>2.09 yd<sup>3</sup></b>
Struck	1.25 m <sup>3</sup>	<b>1.63 yd<sup>3</sup></b>	1.35 m <sup>3</sup>	<b>1.76 yd<sup>3</sup></b>	1.35 m <sup>3</sup>	<b>1.76 yd<sup>3</sup></b>
Cutting Edge, Type	<b>Straight</b>		<b>Straight</b>		<b>Straight</b>	
Bucket Width◀	2378 mm	<b>93.6"</b>	2471 mm	<b>97.3"</b>	2395 mm	<b>94.3"</b>
Teeth	<b>None</b>		<b>8, bolt-on plus replaceable tips</b>		<b>None</b>	
Dump Clearance @ Full Lift and 45° Discharge	2738 mm	<b>107.7"</b>	2499 mm	<b>98.3"</b>	2669 mm	<b>105"</b>
Reach at 45° Discharge Angle 2133 mm (7'0") Clearance	1434 mm	<b>56.5"</b>	1457 mm	<b>57.4"</b>	1428 mm	<b>56.2"</b>
Reach @ Full Lift and 45° Discharge	973 mm	<b>38.3"</b>	1144 mm	<b>45"</b>	1006 mm	<b>39.6"</b>
Digging Depth	142 mm	<b>5.6"</b>	190 mm	<b>7.5"</b>	147 mm	<b>5.8"</b>
Overall Length	6077 mm	<b>239.3"</b>	6401 mm	<b>252"</b>	6167 mm	<b>242.8"</b>
Overall Height	3105 mm	<b>122.2"</b>	3105 mm	<b>122.2"</b>	3105 mm	<b>122.2"</b>
Static Tipping Load	10 831 kg	<b>23,878 lb</b>	10 492 kg	<b>23,130 lb</b>	10 663 kg	<b>23,507 lb</b>
Breakout Force*	137.2 kN	<b>30,843 lb</b>	134.3 kN	<b>30,191 lb</b>	135.5 kN	<b>30,461 lb</b>
Operating Weight**	16 062 kg	<b>35,410 lb</b>	16 302 kg	<b>35,939 lb</b>	16 183 kg	<b>35,677 lb</b>

\* Breakout force is measured 100 mm (3.94") behind tip of cutting edge with bucket hinge pin as pivot point.  
 \*\* Operating weight includes coolant, lubricants, full fuel tank, ROPS cab, General Purpose bucket, and 80 kg (176 lb) operator.  
 ◀ Bolt-on teeth increase bucket width by 52 mm (2"). Bolt-on cutting edge increases bucket width by 17 mm (0.67").

Machine stability can be affected by the addition of other attachments.

BUCKET	General Purpose Bare		General Purpose Bolt-on Cutting Edge		General Purpose Flush Weld-on Adapters & Long Tips		General Purpose Bolt-on Adapters, Long Tips & Segments	
Capacity, Rated (Nominal Heaped)	2.3 m <sup>3</sup>	<b>3.0 yd<sup>3</sup></b>	2.45 m <sup>3</sup>	<b>3.2 yd<sup>3</sup></b>	2.45 m <sup>3</sup>	<b>3.2 yd<sup>3</sup></b>	2.45 m <sup>3</sup>	<b>3.2 yd<sup>3</sup></b>
Struck	2.0 m <sup>3</sup>	<b>2.6 yd<sup>3</sup></b>	2.14 m <sup>3</sup>	<b>2.8 yd<sup>3</sup></b>	2.0 m <sup>3</sup>	<b>2.6 yd<sup>3</sup></b>	2.14 m <sup>3</sup>	<b>2.8 yd<sup>3</sup></b>
Cutting Edge, Type	<b>Straight</b>		<b>Straight</b>		—		<b>Straight</b>	
Bucket Width*	2508 mm	<b>98.7"</b>	2539 mm	<b>99.9"</b>	2583 mm	<b>101.6"</b>	2612 mm	<b>102.8"</b>
Teeth	<b>None</b>		<b>None</b>		<b>8, weld-on plus replaceable tips</b>		<b>8, weld-on plus replaceable tips</b>	
Dump Clearance @ Full Lift and 45° Discharge	3155 mm	<b>124.2"</b>	3068 mm	<b>120.7"</b>	2951 mm	<b>116.1"</b>	2915 mm	<b>114.7"</b>
Reach at 45° Discharge Angle 2133 mm (7'0") Clearance	1771 mm	<b>69.7"</b>	1793 mm	<b>70.5"</b>	1926 mm	<b>75.8"</b>	1886 mm	<b>74.2"</b>
Reach @ Full Lift and 45° Discharge	1060 mm	<b>41.7"</b>	1215 mm	<b>47.8"</b>	1397 mm	<b>55"</b>	1373 mm	<b>54"</b>
Digging Depth	80 mm	<b>3.1"</b>	115 mm	<b>4.5"</b>	95 mm	<b>3.7"</b>	138 mm	<b>5.4"</b>
Ground Clearance from Face of Shoes	471 mm	<b>18.5"</b>	471 mm	<b>18.5"</b>	471 mm	<b>18.5"</b>	471 mm	<b>18.5"</b>
Overall Machine Width without Bucket (with Standard Track) 550 mm (21.6")	2400 mm	<b>94.5"</b>	2400 mm	<b>94.5"</b>	2400 mm	<b>94.5"</b>	2400 mm	<b>94.5"</b>
Overall Machine Width without Bucket (with Narrow Track) 450 mm (18")	2300 mm	<b>90.5"</b>	2300 mm	<b>90.5"</b>	2300 mm	<b>90.5"</b>	2300 mm	<b>90.5"</b>
Overall Length	6584 mm	<b>259.2"</b>	6676 mm	<b>262.8"</b>	6883 mm	<b>270.9"</b>	6896 mm	<b>271.4"</b>
Overall Height	3335 mm	<b>131.3"</b>	3335 mm	<b>131.3"</b>	3335 mm	<b>131.3"</b>	3335 mm	<b>131.3"</b>
Static Tipping Load	14 969 kg	<b>33,000 lb</b>	14 685 kg	<b>32,375 lb</b>	14 815 kg	<b>32,661 lb</b>	14 482 kg	<b>31,927 lb</b>
Breakout Force**	208.6 kN	<b>46,895 lb</b>	206.1 kN	<b>46,333 lb</b>	207.4 kN	<b>46,625 lb</b>	203.8 kN	<b>45,816 lb</b>
Operating Weight***	20 220 kg	<b>44,585 lb</b>	20 433 kg	<b>45,055 lb</b>	20 332 kg	<b>44,832 lb</b>	20 592 kg	<b>45,405 lb</b>

\*With bolt-on cutting edge add 17 mm (0.67"), with bolt-on teeth add 52 mm (2"), for flush weld-on teeth add 75 mm (3").

\*\*Breakout force is measured 100 mm (3.94") behind tip of cutting edge with bucket hinge pin as pivot point.

\*\*\*Operating weight includes coolant, lubricants, full fuel tank, ROPS cab, bucket, and 75 kg (165 lb) operator.

Machine stability can be affected by the addition of other attachments. Add or subtract the following to/from machine operating weight and static tipping load:

	Change in Operating Weight		Change in Static Tipping Load for General Purpose Bucket	
	kg	lb	kg	lb
Ripper (includes ripper, rear lines, and third valves) .....	+639	<b>+1409</b>	+1421	<b>+3133</b>
Rear bumper (removal) .....	-195	<b>- 430</b>	- 464	<b>-1023</b>

BUCKET	Multi-Purpose Bare		Multi-Purpose Bolt-on Segments & Long Teeth		Multi-Purpose Bolt-on Cutting Edge	
Capacity, Rated (Nominal Heaped)	1.9 m <sup>3</sup>	2.5 yd <sup>3</sup>	2.0 m <sup>3</sup>	2.6 yd <sup>3</sup>	2.0 m <sup>3</sup>	2.6 yd <sup>3</sup>
Struck	1.6 m <sup>3</sup>	2.1 yd <sup>3</sup>	1.7 m <sup>3</sup>	2.2 yd <sup>3</sup>	1.7 m <sup>3</sup>	2.2 yd <sup>3</sup>
Cutting Edge, Type	<b>Straight</b>		<b>Straight</b>		<b>Straight</b>	
Bucket Width*	2482 mm	97.7"	2575 mm	101.3"	2515 mm	99"
Teeth	<b>None</b>		<b>8, bolt-on plus replaceable tips</b>		<b>None</b>	
Dump Clearance @ Full Lift and 45° Discharge	3000 mm	118.1"	2772 mm	109.1"	2909 mm	114.5"
Reach at 45° Discharge Angle 2133 mm (7'0") Clearance	1598 mm	62.9"	1650 mm	65.0"	1607 mm	63.3"
Reach @ Full Lift and 45° Discharge	1065 mm	41.9"	1240 mm	48.8"	1119 mm	44"
Digging Depth	161 mm	6.3"	209 mm	8.2"	191 mm	7.5"
Ground Clearance from Face of Shoes	471 mm	18.5"	471 mm	18.5"	471 mm	18.5"
Overall Machine Width without Bucket (with Standard Track) 550 mm (21.6")	2400 mm	94.5"	2400 mm	94.5"	2400 mm	94.5"
Overall Machine Width without Bucket (with Narrow Track) 450 mm (18")	2300 mm	90.5"	2300 mm	90.5"	2300 mm	90.5"
Overall Length	6698 mm	263.7"	7013 mm	276.1"	6820 mm	268.5"
Overall Height	3335 mm	131.3"	3335 mm	131.3"	3335 mm	131.3"
Static Tipping Load	14 487 kg	31,944 lb	14 124 kg	31,143 lb	14 208 kg	31,329 lb
Breakout Force**	193.2 kN	43,333 lb	189.2 kN	42,533 lb	193.7 kN	43,545 lb
Operating Weight***	20 710 kg	45,666 lb	20 975 kg	46,250 lb	20 911 kg	46,109 lb

\*With bolt-on cutting edge add 17 mm (0.67"), for bolt-on teeth add 52 mm (2").

\*\*Breakout force is measured 100 mm (3.94") behind tip of cutting edge with bucket hinge pin as pivot point.

\*\*\*Operating weight includes coolant, lubricants, full fuel tank, ROPS cab, bucket, and 75 kg (165 lb) operator.

Machine stability can be affected by the addition of other attachments.

BUCKET	General Purpose Bare		General Purpose Bolt-on Adapters, Long Tips & Segments		General Purpose Bolt-on Cutting Edge		General Purpose Weld-on Flush Adapters & Tips	
Capacity, Rated (Nominal Heaped)	2.8 m <sup>3</sup>	<b>3.66 yd<sup>3</sup></b>	3.2 m <sup>3</sup>	<b>4.19 yd<sup>3</sup></b>	3.2 m <sup>3</sup>	<b>4.19 yd<sup>3</sup></b>	2.8 m <sup>3</sup>	<b>3.66 yd<sup>3</sup></b>
Struck	2.41 m <sup>3</sup>	<b>3.15 yd<sup>3</sup></b>	2.77 m <sup>3</sup>	<b>3.62 yd<sup>3</sup></b>	2.77 m <sup>3</sup>	<b>3.62 yd<sup>3</sup></b>	2.41 m <sup>3</sup>	<b>3.15 yd<sup>3</sup></b>
Cutting Edge, Type	<b>Straight</b>		<b>Straight</b>		<b>Straight</b>		<b>Spade</b>	
Bucket Width◀	2854 mm	<b>112.4"</b>	2854 mm	<b>112.4"</b>	2854 mm	<b>112.4"</b>	2934 mm	<b>115.5"</b>
Teeth	<b>None</b>		<b>8, bolt-on plus replaceable tips</b>		<b>None</b>		<b>8, weld-on plus replaceable tips</b>	
Dump Clearance @ Full Lift and 45° Discharge	3358 mm	<b>132"</b>	3154 mm	<b>124"</b>	3281 mm	<b>129"</b>	3154 mm	<b>124.2"</b>
Reach @ 45° Discharge Angle 2133 mm (7'0") Clearance	1992 mm	<b>78"</b>	2096 mm	<b>82"</b>	2031 mm	<b>80"</b>	2096 mm	<b>82.5"</b>
Reach @ Full Lift and 45° Discharge	1313 mm	<b>51"</b>	1482 mm	<b>58"</b>	1357 mm	<b>53"</b>	1482 mm	<b>58.3"</b>
Digging Depth	92 mm	<b>3.6"</b>	143 mm	<b>5.6"</b>	122 mm	<b>4.8"</b>	92 mm	<b>3.6"</b>
Ground Clearance from Face of Shoes	457 mm	<b>17.9"</b>	457 mm	<b>17.9"</b>	457 mm	<b>17.9"</b>	457 mm	<b>17.9"</b>
Overall Machine Width without Bucket (with Standard Track)	2580 mm	<b>102"</b>	2580 mm	<b>102"</b>	2580 mm	<b>102"</b>	2580 mm	<b>102"</b>
Overall Machine Width without Bucket (with Wide Track)	2930 mm	<b>115.8"</b>	2930 mm	<b>115.8"</b>	2930 mm	<b>115.8"</b>	2930 mm	<b>115.8"</b>
Overall Length	7092 mm	<b>279"</b>	7362 mm	<b>290"</b>	7175 mm	<b>282"</b>	7372 mm	<b>290.2"</b>
Overall Height	3500 mm	<b>137.8"</b>	3500 mm	<b>137.8"</b>	3500 mm	<b>137.8"</b>	3500 mm	<b>137.8"</b>
Static Tipping Load	20 249 kg	<b>44,649 lb</b>	19 747 kg	<b>43,542 lb</b>	19 908 kg	<b>43,897 lb</b>	20 010 kg	<b>44,122 lb</b>
Breakout Force*	213.3 kN	<b>47,992 lb</b>	194.5 kN	<b>43,762 lb</b>	195.7 kN	<b>44,032 lb</b>	181.3 kN	<b>40,792 lb</b>
Operating Weight**	26 373 kg	<b>58,153 lb</b>	26 731 kg	<b>58,941 lb</b>	26 616 kg	<b>58,688 lb</b>	26 542 kg	<b>58,525 lb</b>

\* Breakout force is measured 100 mm (3.94") behind tip of cutting edge with bucket hinge pin as pivot point.

\*\* Operating weight includes lubricants, full fuel tank, ROPS cab, General Purpose bucket, and 80 kg (176 lb) operator.

◀ Bolt-on teeth increase bucket width by 63.8 mm (2.5"). Bolt-on cutting edge increases bucket width by 19 mm (0.74").

Machine stability can be affected by the addition of other attachments. Add or subtract the following to/from machine operating weight and static tipping load:

	Change in Operating Weight		Change in Static Tipping Load	
	kg	lb	kg	lb
Ripper (includes 3 shanks and rear hydraulic arrangement) .....	+616	<b>+1359</b>	+ 208	<b>+ 458.6</b>
Rear bumper (removal) .....	-582	<b>-1283</b>	-1339	<b>-2952.5</b>



BUCKET	Multi-Purpose Bare		Multi-Purpose Bolt-on Adapters, Long Tips & Segments & Long Teeth		Multi-Purpose Bolt-on Cutting Edge		Steel Mill Arrangement Slag Bucket	
Capacity, Rated (Nominal Heaped)	2.6 m <sup>3</sup>	<b>3.4 yd<sup>3</sup></b>	2.9 m <sup>3</sup>	<b>3.79 yd<sup>3</sup></b>	2.9 m <sup>3</sup>	<b>3.79 yd<sup>3</sup></b>	2.8 m <sup>3</sup>	<b>3.7 yd<sup>3</sup></b>
Struck	2.19 m <sup>3</sup>	<b>2.86 yd<sup>3</sup></b>	2.56 m <sup>3</sup>	<b>3.35 yd<sup>3</sup></b>	2.56 m <sup>3</sup>	<b>3.35 yd<sup>3</sup></b>	—	
Cutting Edge, Type	<b>Straight</b>		<b>Straight</b>		<b>Straight</b>		<b>Straight</b>	
Bucket Width◀	2710 mm	<b>106.7"</b>	2710 mm	<b>106.7"</b>	2710 mm	<b>106.7"</b>	2716 mm	<b>106.9"</b>
Teeth	<b>None</b>		<b>8, bolt-on plus replaceable tips</b>		<b>None</b>		<b>8, weld-on plus replaceable tips</b>	
Dump Clearance @ Full Lift and 45° Discharge	3049 mm	<b>120"</b>	2828 mm	<b>111.3"</b>	2966 mm	<b>116"</b>	2986 mm	<b>117.5"</b>
Reach @ 45° Discharge Angle 2133 mm (7'0") Clearance	1832 mm	<b>72.1"</b>	1936 mm	<b>76.22"</b>	1871 mm	<b>73.6"</b>	1784 mm	<b>70.2"</b>
Reach @ Full Lift and 45° Discharge	1261 mm	<b>49.6"</b>	1403 mm	<b>55.3"</b>	1293 mm	<b>50.9"</b>	1237 mm	<b>48.7"</b>
Digging Depth	200 mm	<b>7.9"</b>	254 mm	<b>10"</b>	230 mm	<b>9.05"</b>	118 mm	<b>4.6"</b>
Overall Length	7333 mm	<b>288.7"</b>	7591 mm	<b>298.9"</b>	7415 mm	<b>291.9"</b>	7600 mm	<b>299.2"</b>
Overall Height	3500 mm	<b>137.8"</b>	3500 mm	<b>137.8"</b>	3500 mm	<b>137.8"</b>	3500 mm	<b>137.8"</b>
Static Tipping Load	19 095 kg	<b>42,104 lb</b>	18 615 kg	<b>41,046 lb</b>	18 309 kg	<b>40,371 lb</b>	18 470 kg	<b>40,720 lb</b>
Breakout Force*	173.9 kN	<b>39,127 lb</b>	159.7 kN	<b>35,932 lb</b>	161.1 kN	<b>36,247 lb</b>	203 kN	<b>45,760 lb</b>
Operating Weight**	27 532 kg	<b>60,698 lb</b>	27 875 kg	<b>61,454 lb</b>	27 775 kg	<b>61,233 lb</b>	29 560 kg	<b>65,180 lb</b>

\* Breakout force is measured 100 mm (3.94") behind tip of cutting edge with bucket hinge pin as pivot point.  
 \*\* Operating weight includes lubricants, full fuel tank, ROPS cab, General Purpose bucket, and 80 kg (176 lb) operator.  
 ◀ Bolt-on teeth increase bucket width by 63.8 mm (2.5"). Bolt-on cutting edge increases bucket width by 19 mm (0.74").

Machine stability can be affected by the addition of other attachments.

BUCKET	General Purpose Bare		General Purpose Bolt-on Adapters, Long Tips & Segments		General Purpose Bolt-on Cutting Edge		General Purpose Flush Weld-on Adapters & Long Tips	
Capacity, Rated (Nominal Heaped)	2.86 m <sup>3</sup>	<b>3.74 yd<sup>3</sup></b>	3.21 m <sup>3</sup>	<b>4.20 yd<sup>3</sup></b>	3.04 m <sup>3</sup>	<b>3.98 yd<sup>3</sup></b>	3.21 m <sup>3</sup>	<b>4.20 yd<sup>3</sup></b>
Struck	2.44 m <sup>3</sup>	<b>3.19 yd<sup>3</sup></b>	2.81 m <sup>3</sup>	<b>3.68 yd<sup>3</sup></b>	2.66 m <sup>3</sup>	<b>3.48 yd<sup>3</sup></b>	2.81 m <sup>3</sup>	<b>3.68 yd<sup>3</sup></b>
Cutting Edge, Type	<b>Straight</b>		<b>Straight</b>		<b>Straight</b>		<b>Spade</b>	
Bucket Width◀	2910 mm	<b>114.6"</b>	2910 mm	<b>114.6"</b>	2910 mm	<b>114.6"</b>	2990 mm	<b>117.7"</b>
Teeth	<b>None</b>		<b>8, bolt-on plus replaceable tips</b>		<b>None</b>		<b>8, weld-on plus replaceable tips</b>	
Dump Clearance @ Full Lift and 45° Discharge	3375 mm	<b>132.9"</b>	3013 mm	<b>118.6"</b>	3193 mm	<b>125.7"</b>	3069 mm	<b>120.8"</b>
Reach @ 45° Discharge Angle 2133 mm (7'0") Clearance	1839 mm	<b>72.4"</b>	2065 mm	<b>81.3"</b>	1929 mm	<b>75.9"</b>	2110 mm	<b>83.1"</b>
Reach @ Full Lift and 45° Discharge	1165 mm	<b>45.9"</b>	1327 mm	<b>52.2"</b>	1199 mm	<b>47.2"</b>	1357 mm	<b>53.4"</b>
Digging Depth	97 mm	<b>3.8"</b>	159 mm	<b>6.3"</b>	127 mm	<b>5.0"</b>	129 mm	<b>5.1"</b>
Ground Clearance from Face of Shoes	483 mm	<b>19.0"</b>	483 mm	<b>19.0"</b>	483 mm	<b>19.0"</b>	483 mm	<b>19.0"</b>
Overall Machine Width without Bucket (with Standard Track)	2710 mm	<b>106.7"</b>	2710 mm	<b>106.7"</b>	2710 mm	<b>106.7"</b>	2710 mm	<b>106.7"</b>
Overall Machine Width without Bucket (with Optional Track)	2835 mm	<b>111.6"</b>	2835 mm	<b>111.6"</b>	2835 mm	<b>111.6"</b>	2835 mm	<b>111.6"</b>
Overall Length	7194 mm	<b>283.2"</b>	7305 mm	<b>287.6"</b>	7275 mm	<b>286.4"</b>	7479 mm	<b>294.4"</b>
Overall Height	3510 mm	<b>138.2"</b>	3510 mm	<b>138.2"</b>	3510 mm	<b>138.2"</b>	3510 mm	<b>138.2"</b>
Static Tipping Load***	21 179 kg	<b>46,700 lb</b>	20 831 kg	<b>45,932 lb</b>	20 959 kg	<b>46,215 lb</b>	21 006 kg	<b>46,318 lb</b>
Breakout Force*	281 kN	<b>63,225 lb</b>	220 kN	<b>49, 500 lb</b>	261 kN	<b>58,725 lb</b>	—	
Operating Weight**	27 371 kg	<b>60,353 lb</b>	27 744 kg	<b>61,176 lb</b>	27 648 kg	<b>60,964 lb</b>	27 478 kg	<b>60,589 lb</b>

\* Breakout force is measured 100 mm (3.94") behind tip of cutting edge with bucket hinge pin as pivot point.

\*\* Operating weight includes lubricants, full fuel tank, ROPS cab, General Purpose bucket, and 80 kg (176 lb) operator.

\*\*\* Safe operating bucket load as defined by SAE for Track Loaders should not exceed 35% of static tipping load.

◀ Bolt-on teeth increase bucket width by 63.8 mm (2.5"). Bolt-on cutting edge increases bucket width by 19 mm (0.74").

Machine stability can be affected by the addition of other attachments. Add or subtract the following to/from machine operating weight and static tipping load:

	Change in Operating Weight		Change in Static Tipping Load	
	kg	lb	kg	lb
Ripper (includes 3 shanks and rear hydraulic arrangement) .....	—	—	—	—
Rear bumper (removal) .....	—	—	—	—

BUCKET	Multi-Purpose Bare		Multi-Purpose Bolt-on Segments & Long Teeth		Multi-Purpose Bolt-on Cutting Edge	
Capacity, Rated (Nominal Heaped)	2.75 m <sup>3</sup>	<b>3.60 yd<sup>3</sup></b>	3.05 m <sup>3</sup>	<b>3.99 yd<sup>3</sup></b>	2.86 m <sup>3</sup>	<b>3.74 yd<sup>3</sup></b>
Struck	2.33 m <sup>3</sup>	<b>3.05 yd<sup>3</sup></b>	2.7 m <sup>3</sup>	<b>3.53 yd<sup>3</sup></b>	2.44 m <sup>3</sup>	<b>3.19 yd<sup>3</sup></b>
Cutting Edge, Type	<b>Straight</b>		<b>Straight</b>		<b>Straight</b>	
Bucket Width◀	2972 mm	<b>117.0"</b>	2972 mm	<b>117.0"</b>	2972 mm	<b>117.0"</b>
Teeth	<b>None</b>		<b>8, bolt-on plus replaceable tips</b>		<b>None</b>	
Dump Clearance @ Full Lift and 45° Discharge	3300 mm	<b>129.9"</b>	3106 mm	<b>122.3"</b>	3229 mm	<b>127.1 mm</b>
Reach @ 45° Discharge Angle 2133 mm (7'0") Clearance	2110 mm	<b>83.1"</b>	2327 mm	<b>91.6"</b>	2160 mm	<b>85.0"</b>
Digging Depth	188 mm	<b>7.4"</b>	244 mm	<b>9.6"</b>	219 mm	<b>8.6"</b>
Ground Clearance from Face of Shoes	582 mm	<b>22.9"</b>	582 mm	<b>22.9"</b>	582 mm	<b>22.9"</b>
Overall Machine Width without Bucket (with Standard Track)	2710 mm	<b>106.7"</b>	2710 mm	<b>106.7"</b>	2710 mm	<b>106.7"</b>
Overall Machine Width without Bucket (with Optional Track)	2835 mm	<b>111.6"</b>	2835 mm	<b>111.6"</b>	2835 mm	<b>111.6"</b>
Overall Length	7445 mm	<b>293.1"</b>	7743 mm	<b>304.8"</b>	7527 mm	<b>296.3"</b>
Overall Height	3510 mm	<b>138.2"</b>	3510 mm	<b>138.2"</b>	3510 mm	<b>138.2"</b>
Static Tipping Load	19 810 kg	<b>43,681 lb</b>	19 455 kg	<b>42,898 lb</b>	19 535 kg	<b>43,075 lb</b>
Breakout Force*	236 kN	<b>53,100 lb</b>	193 kN	<b>43,425 lb</b>	222 kN	<b>49,950 lb</b>
Operating Weight**	28 866 kg	<b>63,650 lb</b>	29 225 kg	<b>64,441 lb</b>	29 143 kg	<b>64,260 lb</b>

\* Breakout force is measured 100 mm (3.94") behind tip of cutting edge with bucket hinge pin as pivot point.

\*\* Operating weight includes lubricants, full fuel tank, ROPS cab, General Purpose bucket, and 80 kg (176 lb) operator.

◀ Bolt-on teeth increase bucket width by 63.8 mm (2.5"). Bolt-on cutting edge increases bucket width by 19 mm (0.74").

Machine stability can be affected by the addition of other attachments.

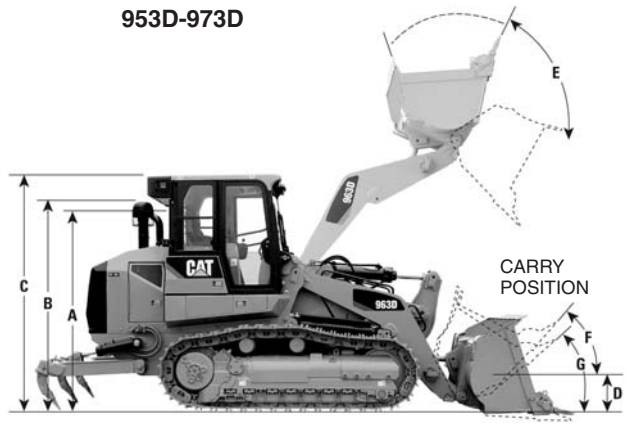
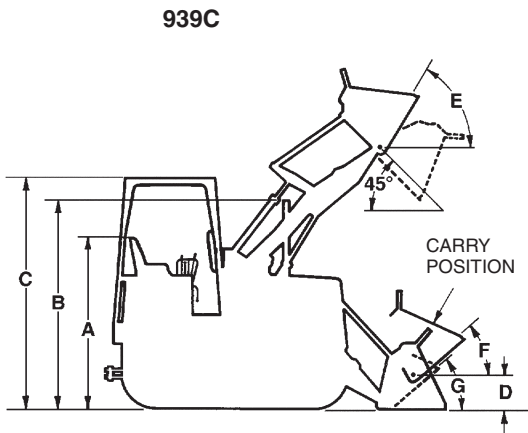

	939C		953D		963D	
A Height to Top of Seat	2000 mm	79"	2560 mm	100.7"	2790 mm	109.8"
B Height to Top of Stack	2810 mm	110"	2783.5 mm	109.6"	2953 mm	116"
C Height to Top of ROPS	2760 mm	108"	3105 mm	122.2"	3335 mm	131"
D Hinge Pin Height at Carry Position	414 mm	16.3"	421 mm	16.5"	467 mm	18"
E Rollback at Maximum Lift		67.7°		56°		52°
F Rollback at Carry Height		51.2°		48°		50°
G Rollback at Ground Level		42.6°		41°		43°
Grading Angle (Bare Edge)		—		74°		63°
Width without Bucket (standard track)	1960 mm	77"	2280 mm	89.7"	2400 mm	94"
(optional track)	2010 mm	79"	2180 mm	85.8"	2300 mm	90.5"
Weight of General Purpose Bucket with Teeth & Segments		—	1266 kg	2792 lb	1866 kg	4114 lb
	<b>973C</b>		<b>973D</b>			
A Height to Top of Seat	2970 mm	116.92"	2975 mm	117.1"		
B Height to Top of Stack	2989 mm	117.67"	3018 mm	118.8"		
C Height to Top of ROPS	3500 mm	137.79"	3510 mm	138.2"		
D Hinge Pin Height at Carry Position	505 mm	19.58"	483 mm	19.0"		
E Rollback at Maximum Lift		58°		59°		
F Rollback at Carry Height		51°		49°		
G Rollback at Ground Level		42°		42°		
Grading Angle (Bare Edge)		69°		85°		
Width without Bucket (standard track)	2580 mm	101.57"	2710 mm	106.7"		
(optional track)	2755 mm	108.5"	2835 mm	111.6"		
Weight of General Purpose Bucket with Teeth & Segments	2183 kg	4814 lb	2090 kg	4608 lb		

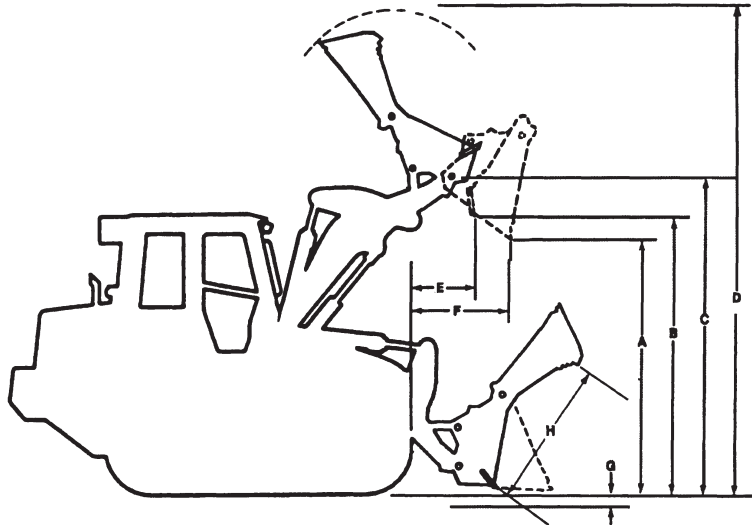

	<b>939C</b>		<b>953D</b>		<b>963D</b>	
<b>A</b> Forward Dump Clearance*	2680 mm	<b>106"</b>	2738 mm	<b>107.7"</b>	3000 mm	<b>118"</b>
<b>B</b> Bottom Dump Clearance*	3050 mm	<b>120"</b>	3181 mm	<b>125.2"</b>	3450 mm	<b>135.8"</b>
<b>C</b> Hinge Pin Height*	3320 mm	<b>131"</b>	3610 mm	<b>142.1"</b>	3940 mm	<b>155"</b>
<b>D</b> Overall Height	4680 mm	<b>184"</b>	4871 mm	<b>192"</b>	5308 mm	<b>209"</b>
<b>E</b> Bottom Dump Reach	453 mm	<b>18"</b>	559 mm	<b>22"</b>	627 mm	<b>24.7"</b>
<b>F</b> Forward Dump Reach*	776 mm	<b>31"</b>	973 mm	<b>38"</b>	1079 mm	<b>42.5"</b>
<b>G</b> Digging Depth	127 mm	<b>5"</b>	142 mm	<b>5.6"</b>	161 mm	<b>6.3"</b>
<b>H</b> Bucket Opening	930 mm	<b>36"</b>	1061 mm	<b>41.7"</b>	1248 mm	<b>49"</b>
Reach at 2133 mm (7'0") Height*	1200 mm	<b>47"</b>	1434 mm	<b>56.4"</b>	1598 mm	<b>63"</b>
Tilt Back at Ground Level		<b>43°</b>		<b>42°</b>		<b>45°</b>
Closure Force, Clamp to Cutting Edge	56.8 kN	<b>12,780 lb</b>		<b>N/A</b>		<b>N/A</b>
Weight of Bucket with Teeth, Segments and Additional Hydraulics	1005 kg	<b>2216 lb</b>	1762 kg	<b>3884.5 lb</b>	2236 kg	<b>4930 lb</b>
	<b>973C</b>		<b>973D</b>			
<b>A</b> Forward Dump Clearance*	2830 mm	<b>111.41"</b>	3138 mm		<b>123.5"</b>	
<b>B</b> Bottom Dump Clearance*	3660 mm	<b>144.09"</b>	3670 mm		<b>144"</b>	
<b>C</b> Hinge Pin Height*	4240 mm	<b>166.92"</b>	4234 mm		<b>166.7"</b>	
<b>D</b> Overall Height	5800 mm	<b>228.34"</b>	5651 mm		<b>222.4"</b>	
<b>E</b> Bottom Dump Reach	693 mm	<b>27.28"</b>	655 mm		<b>26"</b>	
<b>F</b> Forward Dump Reach*	1403 mm	<b>55.23"</b>				
<b>G</b> Digging Depth	254 mm	<b>9.99"</b>	159 mm		<b>6.26"</b>	
<b>H</b> Bucket Opening	1380 mm	<b>54.33"</b>				
Reach at 2133 mm (7'0") Height*	1936 mm	<b>76.22"</b>	2327 mm		<b>92"</b>	
Tilt Back at Ground Level		<b>45°</b>			<b>45°</b>	
Closure Force, Clamp to Cutting Edge	89 kN	<b>20,000 lb</b>				
Weight of Bucket with Teeth, Segments and Additional Hydraulics	3560 kg	<b>7850 lb</b>	3453 kg		<b>7614 lb</b>	

\*45° Discharge and full lift.  
 Operator may prefer to tip bucket forward when bottom dumping.

TRACK LOADER	939C		953D		963D	
Ripper-Scarifier Type	Radial		Radial		Radial	
Dimensions:						
<b>Ripper Shank</b>						
Maximum Penetration Depth	205 mm	<b>8.1"</b>	240 mm	<b>9.45"</b>	330 mm	<b>12.99"</b>
Maximum Reach at Ground Line (from track to teeth on ground)	627 mm	<b>24.7"</b>	1350 mm	<b>53"</b>	1585 mm	<b>62.4"</b>
Maximum Ground Clearance under Tip (shank pinned in bottom hole)	593 mm	<b>23.3"</b>	552 mm	<b>21.7"</b>	667 mm	<b>26.3"</b>
Maximum Ramp Angle, Ripper Up (shank pinned in bottom hole)	<b>33.5°</b>		<b>18°</b>		<b>17°</b>	
Shank Section	36 × 76 mm <b>1.4" × 3"</b>		50 × 109 mm <b>2.0" × 4.3"</b>		58.5 × 138 mm <b>2.3" × 5.4"</b>	
<b>Ripper Beam</b>						
Overall Width	1580 mm	<b>62"</b>	1950 mm	<b>76.8"</b>	1950 mm	<b>76.7"</b>
Height	130 mm	<b>5.1"</b>	165 mm	<b>6.5"</b>	165 mm	<b>6.5"</b>
Length	140 mm	<b>5.5"</b>	211 mm	<b>8.3"</b>	211 mm	<b>8.3"</b>
Number of Pockets	<b>5</b>		<b>3</b>		<b>3</b>	
Pocket Spacing	356 mm	<b>14"</b>	900 mm	<b>35.4"</b>	896 mm	<b>35.2"</b>
Shank Gauge	1420 mm	<b>56"</b>	1800 mm	<b>70.8"</b>	1792 mm	<b>70.5"</b>
Track Clearance with Standard Shoe	139 mm	<b>5.5"</b>	105.2 mm	<b>4.1"</b>	225.3 mm	<b>8.9"</b>
Installed Weights:						
Ripper with Standard Shank (1 shank)	250 kg	<b>550 lb</b>	581 kg	<b>1281 lb</b>	713 kg	<b>1572 lb</b>
Each Additional Shank	11 kg	<b>24 lb</b>	25 kg	<b>55 lb</b>	36 kg	<b>79 lb</b>
<b>Ripper Forces*</b>						
Penetration Force at Ground Level	2687 kg	<b>5924 lb</b>	50 kN	<b>11,240 lb</b>	64 kN	<b>14,400 lb</b>
Pryout Force at Maximum Digging Depth	5265 kg	<b>11,610 lb</b>	116 kN	<b>26,077 lb</b>	151 kN	<b>33,946 lb</b>

\*These values may vary slightly with different vehicle configurations.

<b>TRACK LOADER</b>	<b>973C</b>		<b>973D</b>	
<b>Ripper-Scarifier Type</b>	<b>Radial</b>		<b>Parallelogram</b>	
Dimensions:				
<b>Ripper Shank</b>				
Maximum Penetration Depth	377 mm	<b>14.84"</b>	397 mm	<b>15.6"</b>
Maximum Reach at Ground Line (from track to teeth on ground)	1770 mm	<b>69.7"</b>	1938 mm	<b>76.3"</b>
Maximum Ground Clearance under Tip (shank pinned in bottom hole)	688 mm	<b>27.09"</b>	888 mm	<b>34.9"</b>
Maximum Ramp Angle, Ripper Up (shank pinned in bottom hole)	<b>20°</b>		<b>28.5°</b>	
Shank Section	74 × 175 mm <b>2.9" × 6.9"</b> (Curved)		74 × 175 mm <b>2.9" × 6.9"</b>	
<b>Ripper Beam</b>				
Overall Width	2200 mm	<b>86.61"</b>	2200 mm	<b>86.6"</b>
Height	216 mm	<b>8.5"</b>	216 mm	<b>8.5"</b>
Length	254 mm	<b>10"</b>	254 mm	<b>10"</b>
Number of Pockets	<b>3</b>		<b>3</b>	
Pocket Spacing	1000 mm	<b>39.36"</b>	875 mm	<b>34.4"</b>
Shank Gauge	2000 mm	<b>78.73"</b>	1750 mm	<b>68.9"</b>
Track Clearance with Standard Shoe	<b>N/A</b>		<b>N/A</b>	
Installed Weights:				
Ripper with Standard Shank (1 shank)	1196 kg	<b>2636 lb</b>	1700 kg	<b>3747 lb</b>
Each Additional Shank	<b>3 shanks std.</b>		<b>3 shanks std.</b>	
<b>Ripper Forces*</b>				
Penetration Force at Ground Level	85 kN	<b>19,125 lb</b>	100 kN	<b>22,500 lb</b>
Pryout Force at Maximum Digging Depth	175 kN	<b>39,375 lb</b>	242 kN	<b>54,450 lb</b>

\*These values may vary slightly with different vehicle configurations.

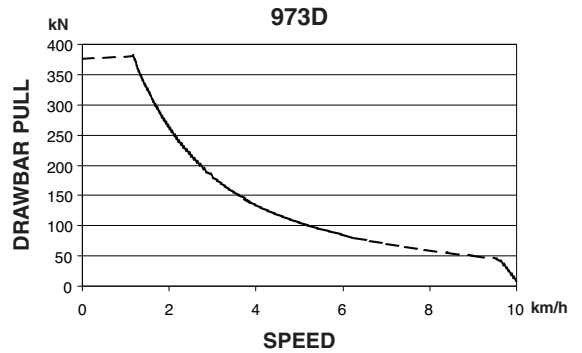
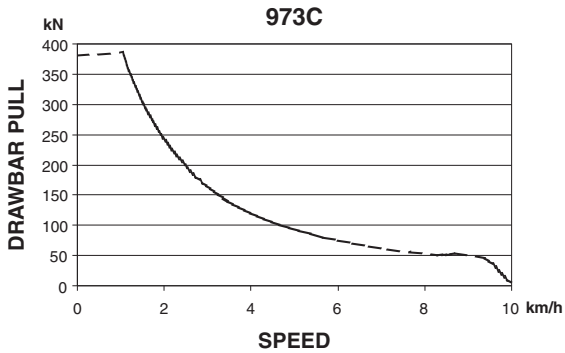
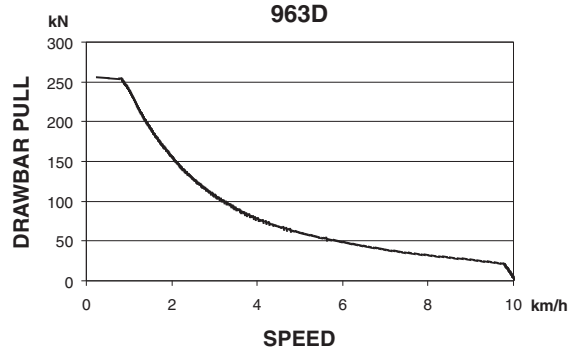
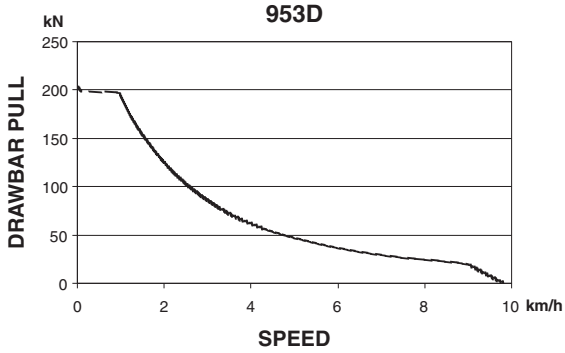

**NOTES:** Usable pull will depend upon weight and traction of equipped tractor.  
 Assumes sufficient machine weight for <5% track slip at POR pressure.  
 Assumes pumps and motors are broken in.  
 Assumes nominal engine power and valve settings.  
 Drawbar pull at track stall will be lower.

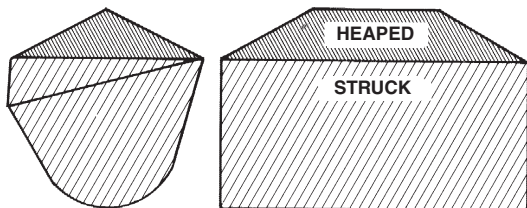

**SAE BUCKET RATING****SAE Bucket Capacities**

*Struck capacity* is that volume contained in a bucket after a load is leveled by drawing a straight edge resting on the cutting edge and the back of the bucket.

*Heaped capacity* is a struck capacity *plus* that additional material that would heap on the struck load at a 2:1 angle of repose with the struck line parallel to the ground.

SAE J742 (Oct. 79) specifies that the addition of any auxiliary spill guard to protect against spillage of material which might injure the operator will not be included in bucket capacity ratings. Buckets with irregular shaped cutting edges (vee edge) the strike plane should be drawn at one-third the distance of the protruding portion of the cutting edge. Cat rock buckets are built with integral see-through rock guards. Cat light material buckets come standard with bolt-on edges. These features which add to actual bucket capacity are included in published ratings.

**Dump Height**

SAE J732 JUN92 specifies that dump height is the vertical distance from the ground to the lowest point of the cutting edge with the bucket hinge pin at maximum height and the bucket at a 45° dump angle. Dump angle is the angle in degrees that the longest flat section of the inside bottom of the bucket will rotate below horizontal.

**Static Tipping Load**

The minimum weight at center of gravity of “SAE Rated” load in bucket which will rotate rear of machine to a point where, on track loaders, front rollers are clear of the track under the following conditions:

- a. Loader on hard level surface and stationary.
- b. Unit at standard operating weight.
- c. Bucket at maximum rollback position.

- d. Load at maximum forward position during raising cycle.
- e. Unit with standard equipment as described in specifications unless otherwise noted under the heading.

**Operating Load**

In order to comply with SAE standard J818 MAY87, the operating load for track loaders should not exceed 35% of the Static Tipping load rating. See “Performance Data” of each machine in this handbook for increases to static tipping load by adding cab, counterweights, ripper-scarifier, etc.

**SELECTING A MACHINE****Steps in selecting the proper size loader:**

1. Determine production required or desired.
2. Determine loader cycle time and cycles per hour. A machine size must be assumed to select a basic cycle time.
3. Determine required payload per cycle in loose cubic yards and pounds (meters and kilograms).
4. Determine bucket size needed.
5. Make machine selection using bucket size and payload as criteria to meet production requirements.
6. Compare the loader cycle time used in calculations to the cycle time of the machine selected. If there is a difference, rework the process beginning at step 2.

**1. Production Required**

The production required of a track loader should be slightly greater than the production capability of the other critical units in the earth or material moving system. For example, if a hopper can handle 300 tons per hour, a loader capable of slightly more than 300 tons should be used. Required production should be carefully calculated so the proper machine and bucket selections are made.

**2. Loader Cycle Times**

Material type, pile height, and other factors may improve or reduce production, and should be added to or subtracted from the basic cycle time when applicable.

When hauls are involved, obtain haul and return portions of the cycle from the estimated travel chart (this section). Add the haul and return times to the estimated basic cycle time to obtain total cycle time.

**CYCLE TIME FACTORS**

A basic cycle time (Load, Dump, Maneuver) of 0.25-0.35 minutes is average for a track loader [the basic cycle for large track loaders, 2 m<sup>3</sup> (2.6 yd<sup>3</sup>) and up, can be slightly longer], but variations can be authenticated in the field. The following values for many variable elements are based on normal operations. Adding or subtracting any of the variable times will give the total basic cycle time.

**Estimating Cycle Time**

Cycle time of a track loader needs to be determined to find loads per hour. Total cycle time includes the following segments:

Load Time + Maneuver Time + Travel Time + Dump Time

**Load Time —**

<b>Material</b>	<b>Minutes</b>
Uniform aggregates	0.03-0.05
Moist mixed aggregates	0.03-0.06
Moist loam	0.03-0.07
Soil, boulders, roots	0.04-0.20
Cemented materials	0.05-0.20

**Maneuver Time —** includes basic travel, four changes of direction and turning time, and will be about 0.20 minutes with a competent operator.

**Travel Time —** in a load and carry operation is comprised of haul and return times which can be determined by the travel charts in this section.

**Dump Time —** is dictated by the size and strength of the dump target and varies from 0.00 to 0.10 minutes. Typical dump times into highway trucks are from 0.04 to 0.07 minutes.

**NOTE:** When comparing hydrostatic track loaders with former power shift models (using the production estimating method) two factors must be considered: (1) The hydrostatic track loaders on the average outcycle power shift models by up to 10 percent due to faster machine speed and easier operation. (2) Larger, rear engine hydrostatic track loaders incorporate Z-bar linkage, which provides substantially better bucket fill factors. The degree to which each factor affects estimated production should be left to the user's judgment depending on the particular job application and conditions.

Example: Moist loam is being excavated from a bank and loaded into trucks.

	<b>Minutes</b>
Load — moist loam	0.05
Maneuver Time	0.20
Travel — none required	0.00
Dump	<u>0.05</u>
Total Cycle	0.30 min. or 200 cycles per 60 min. hour

*Minutes added (+)  
or Subtracted (-)  
From Basic Cycle*

**Materials**

- Mixed . . . . .+0.02
- Up to 3 mm (1/8 in) . . . . .+0.02
- 3 mm (1/8 in) to 20 mm (3/4 in) . . . . .-0.02
- 20 mm (3/4 in) to 150 mm (6 in) . . . . . 0.00
- 150 mm (6 in) and over . . . . .+0.03 and Up
- Bank or broken . . . . .+0.04 and Up

**Pile**

- Conveyor or Dozer piled 3 m (10 ft) and up . . . . . 0.00
- Conveyor or Dozer piled 3 m (10 ft) or less . . . . .+0.01
- Dumped by truck . . . . .+0.02

**Miscellaneous**

- Common ownership of trucks and loaders . . . . .Up to -0.04
- Independently owned trucks . . . . .Up to +0.04
- Constant operation . . . . .Up to -0.04
- Inconsistent operation . . . . .Up to +0.04
- Small target . . . . .Up to +0.04
- Fragile target . . . . .Up to +0.05

Using actual job conditions and the above factors, total cycle time can be estimated. Convert total cycle time to cycles per hour.

$$100\% \text{ Efficiency } = \frac{60 \text{ Min}}{\text{Total Cycle Time in Minutes}}$$

Job efficiency is an important factor in machine selection. Efficiency is the actual number of minutes worked during an hour. Job efficiency accounts for operator breaks, and other work interruptions. See "Efficiency Considerations" page 13-23.

- Bucket Fill Factors
  - Recommended Operating Capacities
- ## Loader Production

### Bucket Fill Factors

The following indicates the approximate amounts of material as a percent of rated bucket capacity which will actually be delivered per bucket per cycle. This is known as “Bucket Fill Factor.”

Loose Material	Fill Factor
Mixed Moist Aggregates	95-110%
Uniform Aggregates	
up to 3 mm (1/8 in)	95-110
3 mm-9 mm (1/8 in-3/8 in)	90-110
12 mm-20 mm (1/2 in-3/4 in)	90-110
24 mm and over (1 in)	90-110
<b>Blasted Rock</b>	
Well	80-95%
Average	75-90
Poor	60-75
<b>Other</b>	
Rock Dirt Mixtures	100-120%
Moist Loam	100-120
Soil, Boulders, Roots	80-100
Cemented Materials	85-100

Fill factors on track loaders are affected by bucket penetration, breakout force, rackback angle, bucket profile and ground engaging tools such as bucket teeth and segments or bolt-on replaceable cutting edges.

### GENERAL PURPOSE BUCKET W/TEETH & SEGMENTS MAXIMUM OPERATING CAPACITIES

MODEL	GENERAL PURPOSE BUCKET SIZE		MAXIMUM OPERATING CAPACITY	
	m <sup>3</sup>	yd <sup>3</sup>	kg	lb
939C	1.15	1.5	2040	4500
953D	1.85	2.4	3182	7015
963D	2.45	3.2	4214	9290
973C	3.2	4.2	5504	12,134
973D	3.21	4.2	5521	12,174

### LOADER PRODUCTION

Loader production equals quantity of material the bucket carries per load × number of bucket loads per hour.

#### Estimating Bucket Load

The quantity of material in a loader bucket is estimated by two methods, depending on whether the material being loaded is in a loose or bank state.

1. When the material is loose, as in stockpile loading, the bucket load is estimated in loose meters (or cubic yards) by a Bucket Fill Factor (see Tables Section or chart following this discussion). The quantity of material is determined as follows:

$$\text{Rated Bucket Capacity} \times \text{Bucket Fill Factor} = \text{Bucket Payload in Loose m}^3 \text{ (yd}^3\text{)}$$

For example, a 973 with a 3.2 m<sup>3</sup> (4.2 yd<sup>3</sup>) General Purpose bucket loading moist loam material will carry:

$$3.2 \text{ m}^3 \times 1.15 = 3.68 \text{ loose cubic meters}$$

$$(4.2 \text{ yd}^3 \times 1.15 = 4.83 \text{ loose cubic yards})$$

Once the potential bucket load has been determined, check the static tipping load ratings on the specific machine to determine if bucket load is in fact a safe operating load. (*Safe operating load as defined by SAE for track loaders should not exceed 35% of static tipping load.*)

Productivity in many applications is measured in tons. See Tables Section for material densities if conversion to tons is desired.

2. When material is in the bank state, as in excavation, productivity is measured in bank meters (cubic yards). Bucket load in Bm<sup>3</sup> (BCY) is estimated by applying one of the load factors from the Tables section to convert the excavated material in the bucket from Bm<sup>3</sup> (BCY) to Lm<sup>3</sup> (LCY) to allow for the digging and carrying characteristics of the material. The quantity of excavated material a bucket carries is then determined as follows:

$$\text{Rated Bucket Capacity} \times \text{Load Factor} \times \text{Bucket Fill Factor} = \text{Bucket Payload in Bm}^3 \text{ (BCY)}$$

Example: a 953D with a 1.85 m<sup>3</sup> (2.4 yd<sup>3</sup>) General Purpose bucket loading wet loam earth from bank:

$$1.85 \text{ m}^3 \times 0.79 \times 1.15 = 1.68 \text{ Bm}^3$$

$$(2.4 \text{ yd}^3 \times 0.79 \times 1.15 = 2.18 \text{ BCY})$$

- Estimating Production
- Alternative Machine Selection Method

**Estimating Production**

Machine and job considerations include:

- Machine model and bucket size
- Material type, particle size, density and load factor (see Tables Section)
- Bucket fill factor
- Haul distance
- Underfoot conditions
- Altitude
- Dump target size, height, and type

Example:

**Conditions —**

Machine	953D
Bucket size	1.85 m <sup>3</sup> (2.4 yd <sup>3</sup> )
Material	Moist Loam
Bucket fill factor	1.15
Haul length	30 m (100 ft)
Dump target	Pile
Travel in forward speed	

**Cycle Time**

**Minutes**

Load time	0.15
Maneuver time	0.20
Travel time (from curves)	0.40
Dump time	0.05
Total	0.80

**Loads Per Hour —**

$$\frac{60 \text{ min/hr}}{0.80 \text{ min/cycle}} = 75 \text{ cycles per hour @ 100\% efficiency}$$

**Load Per Cycle —**

$$1.85 \text{ m}^3 \times 1.15 \text{ BFF} = 2.13 \text{ Lm}^3 \times 0.81 \text{ LF} = 1.72 \text{ Bm}^3$$

$$(2.4 \text{ yd}^3 \times 1.15 \text{ BFF} = 2.76 \text{ LCY} \times 0.81 \text{ LF} = 2.24 \text{ BCY})$$

**Hourly Production —**

$$1.72 \text{ Bm}^3 \times 75 \text{ cycles/h} = 129 \text{ Bm}^3/\text{h}$$

$$(2.24 \text{ BCY} \times 75 \text{ cycles/hr} = 168 \text{ BCY/hr})$$

More accurate production estimates can be made by recording actual machine cycle times in the same or similar application. Then visually verify the approximate bucket fill factor.

**Efficiency Considerations**

Loader capacity should always be matched to peak production requirements of the job. Actual “on-the-job” loader productivity will be influenced by factors such as operator skill, personal delays, job layout and other delays. Experience and knowledge of local conditions will be the best indicators of actual job efficiency.

Operation	Working Hour	Efficiency Factor
Day	50 min/Hr	0.83

**An Alternative Machine Selection Method**

Another method of selecting the right Track Loader and bucket to meet production requirements is by use of the nomographs on the following pages. The method is quicker and easier than the preceding example because it does not require as many calculations, yet the accuracy is about the same within the normal limits of input data.

Be careful when entering and reading data from the nomographs because some scales increase from bottom to top, while others are the reverse. Do not be overly concerned with the precision as affected by pencil line width or reading to the hundredth of a m<sup>3</sup> (yd<sup>3</sup>). Remember that bucket fill factor, material density, and cycle time are at best close estimates.

Example problem

A track loader must produce 200 Lm<sup>3</sup> (262 LCY) per hour. Estimated cycle time is 0.5 minutes, working 50 minutes per hour. Bucket fill factor is 110% and the material density is 1600 kg/Lm<sup>3</sup> (2700 lb/LCY).

Determine bucket size, machine model and hourly production in tons and yards.

**Solution**

At full efficiency, it will cycle 120 times per hour. Since only an average 50 minutes are available, only 100 cycles will be completed per hour.

Starting on Scale A at 100 cycles per hour draw a straight line intersecting 200 m<sup>3</sup>/hr (262 yd<sup>3</sup>/hr) on Scale B and continuing the line on to Scale C giving 2.0 m<sup>3</sup> (2.62 yd<sup>3</sup>) required payload.

Follow steps 1 through 7 on the next two pages.



# Track Loaders

## Production and Machine Selection Nomograph

- To find required bucket payload and bucket size

- 1) Enter Scale A cycles per hour (100) and B hourly production 200 m<sup>3</sup>/hr (262 yd<sup>3</sup>/hr).
- 2) Connect A and B and extend to C to find required payload 2.0 m<sup>3</sup> (2.62 yd<sup>3</sup>).
- 3) Connect C to bucket fill factor on Scale D (110%) and extend to E to find required bucket size 1.8 m<sup>3</sup> (2.35 yd<sup>3</sup>).
- 4) Transfer Scale A and C readings to nomograph on following page.

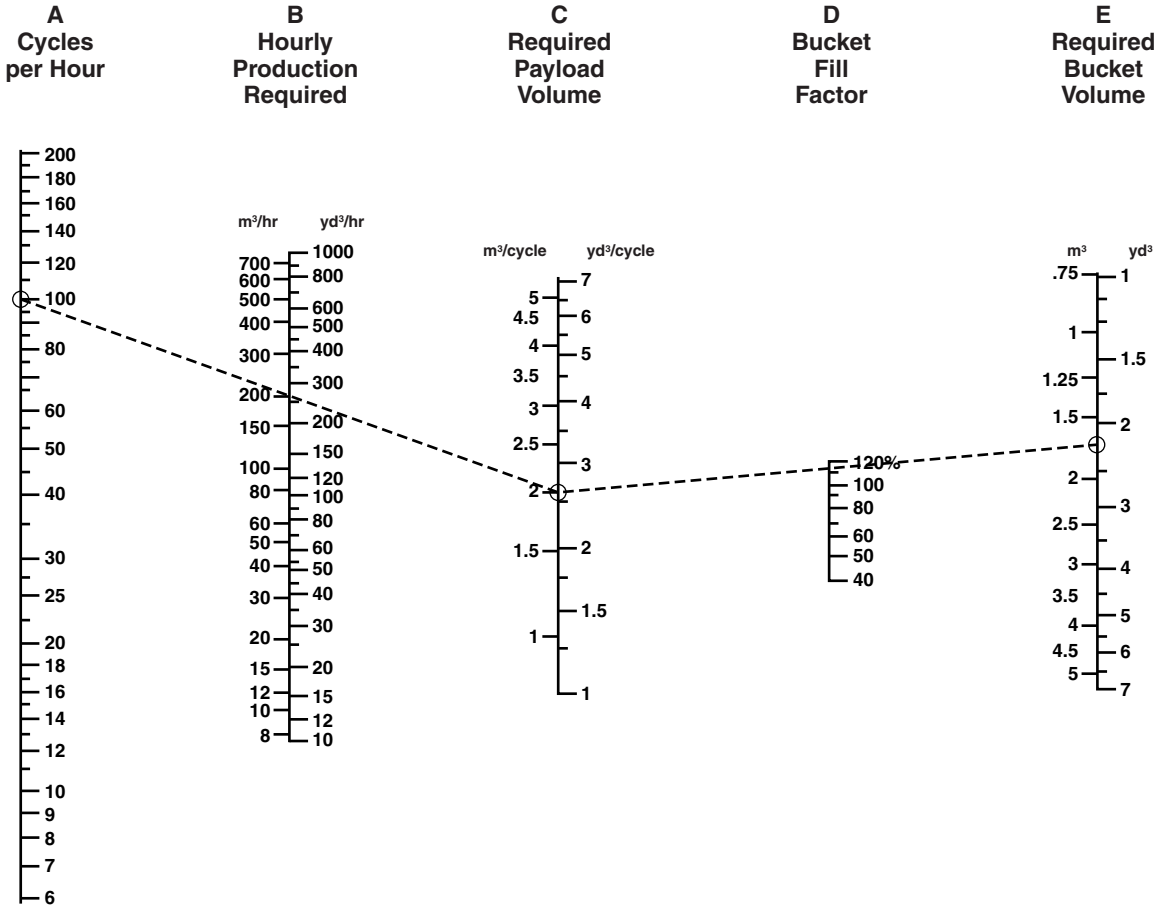

# Production and Machine Selection Nomograph

## Track Loaders

- To find payload weight for stability and output in tons per hour

- 5) Connect C 1.8 m<sup>3</sup> (2.35 yd<sup>3</sup>) to F 1600 kg/m<sup>3</sup> (2700 lb/yd<sup>3</sup>) and extend to G to find payload weight 2880 kg (6345 lb).
- 6) Compare G bucket payload weight 2880 kg (6345 lb) with maximum operating capacities table in this section to see if the 1.85 m<sup>3</sup> (2.4 yd<sup>3</sup>) bucket can handle the desired payload. Table indicates the

953D with a 1.85 m<sup>3</sup> (2.4 yd<sup>3</sup>) bucket equipped with bolt-on cutting edge or teeth and segments has a greater operating capacity of 3343 kg (7370 lb), therefore stability is okay.

- 7) Extend Scale G reading 2880 kg (6345 lb) through Scale A (100) to Scale I to find tons per hour 288 metric ton/hr (317 U.S. ton/hr).

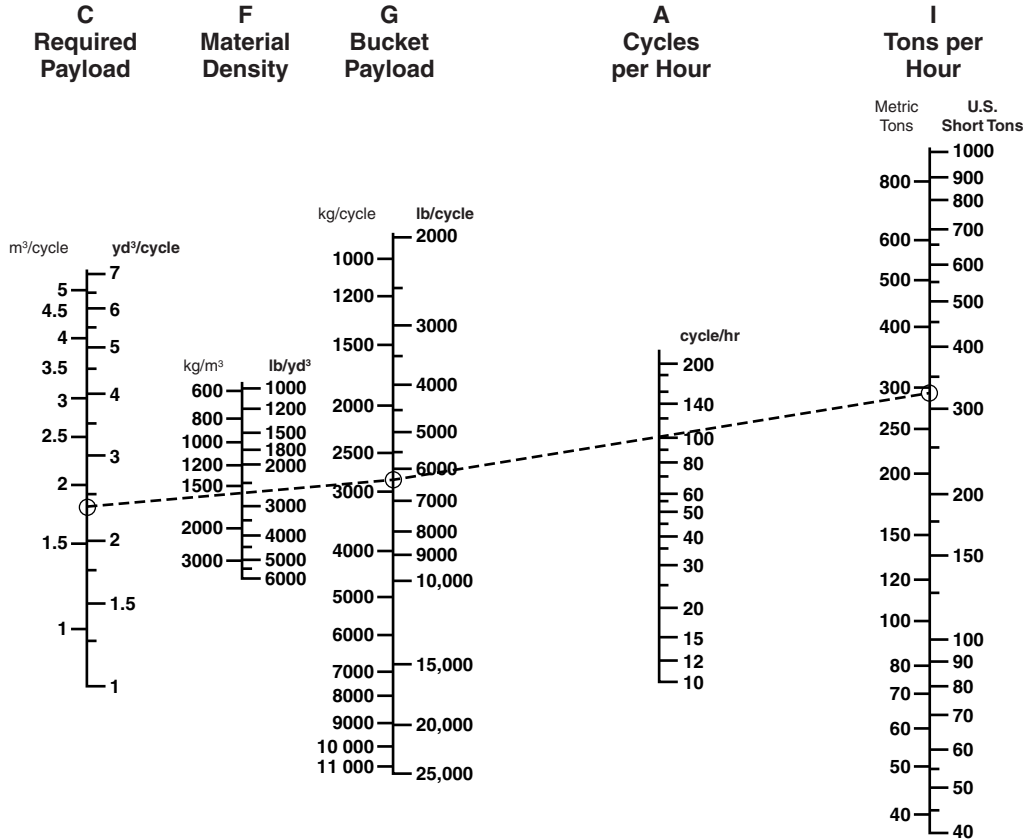

**TRAVEL TIME CHARTS**

**Conditions:**

- No grades.
- Speeds loaded and empty essentially the same.
- Bucket position constant during travel.
- Travel encountered in maneuver time portion of cycle not included.
- Acceleration time accounted for in maneuver time.

Travel Time (in minutes) =

*Metric* —  $\frac{\text{number of meters traveled}}{\text{speed (in km/h)} \times 16.67}$

*English* —  $\frac{\text{number of feet traveled}}{\text{speed (in mph)} \times 88}$

**939C**

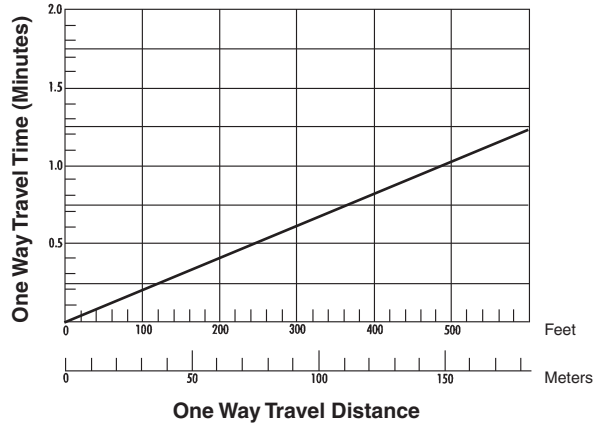

**953D**

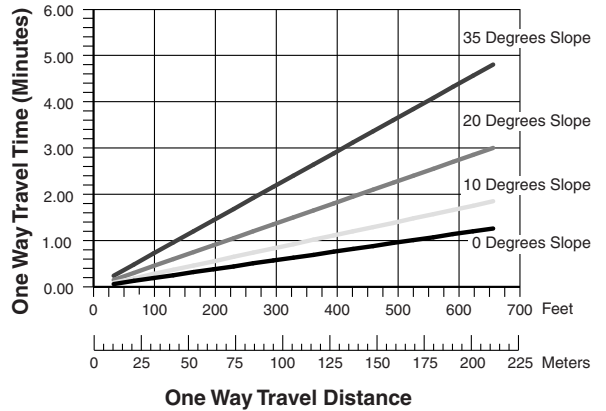

**KEY**

939C — Hydrostatic top speed both forward and reverse 10 km/h (6.2 mph).

953D — Hydrostatic top speed both forward and reverse 10 km/h (6.2 mph)

963D

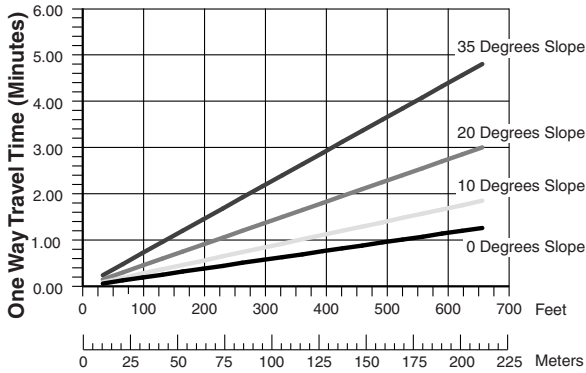

One Way Travel Distance

973C

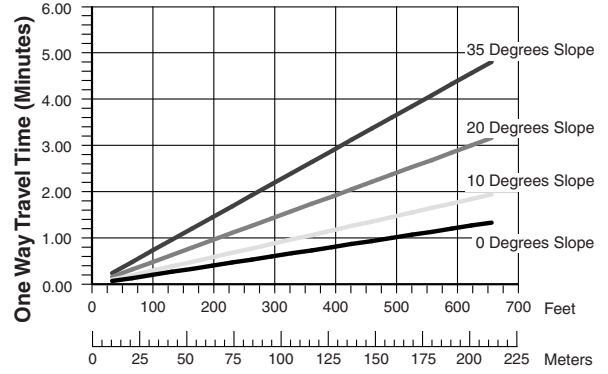

One Way Travel Distance

973D

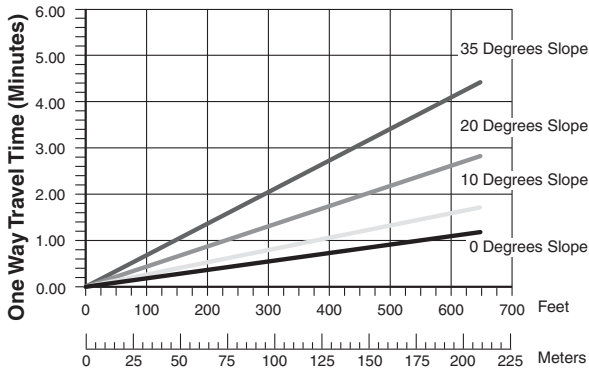

One Way Travel Distance

TRAVEL TIME CHARTS

Conditions:

- No grades.
- Speeds loaded and empty essentially the same.
- Bucket position constant during travel.
- Travel encountered in maneuver portion of cycle not included.
- Acceleration time accounted for in maneuver time.

Travel Time (in minutes) =

$$\text{Metric} = \frac{\text{number of meters traveled}}{\text{speed (in km/h)} \times 16.67}$$

$$\text{English} = \frac{\text{number of feet traveled}}{\text{speed (in mph)} \times 88}$$

KEY

963D — Hydrostatic top speed both forward and reverse 10 km/h (6.2 mph)

973C — Hydrostatic top speed both forward and reverse 10 km/h (6.2 mph)

973D — Hydrostatic top speed both forward and reverse 11 km/h (6.83 mph)



# Track Loaders

## Production Estimating Table

- $m^3$  or  $yd^3/60$  min. hour
- Estimated bucket payload in bank  $m^3$  or  $yd^3$

Bucket Size ( $m^3$ or $yd^3$ )		1.0	1.5	2.0	2.5	3.0	3.5	4.0	4.5	5.0
Cycle Time Hundredths of a minute	Cycles Per Hr	Unshaded area indicates average work range								
		0.25	240	240	360	480	600	720	840	960
0.30	200	200	300	400	500	600	700	800		
0.35	171	171	257	342	428	513	599	684	769	
0.40	150	150	225	300	375	450	525	600	675	750
0.45	133	133	200	268	332	400	466	530	600	665
0.50	120	120	180	240	300	360	420	480	540	600
0.55	109	109	164	218	272	328	382	436	490	545
0.60	100	100	150	200	250	300	350	400	450	600
0.65	92	92	138	184	230	276	322	368	416	460

Work Tools	939C	953D	963D	973C	973D
Quick Coupler	X	X	X	X	X
General Purpose (GP) bucket	X	X	X	X	X
GP bucket with trash rack		X	X	X	X
MP bucket with trash rack		X	X	X	X
Landfill bucket		X	X	X	X
Landfill Multi-purpose		X	X	X	X
Multi-purpose (MP) bucket	X	X	X	X	X
Trim blade		X	X	X	X
Slag bucket				X	X
Forks (for QC or bucket)		X	X	X	X
Material handling arm		X	X	X	X
Loader rake		X	X	X	X
Top-Clamp bucket		X		X	X
Side Dump bucket		X	X	X	X

## SHOE OPTIONS



① **Double Grouser Shoes**

- **Extreme service shoes** are available which have more hardened wear material for longer wear life and higher impact applications.



② **Trapezoidal Center Hole Shoes**



③ **Single Grouser Shoes**

- **Wider shoes** are also available to reduce ground pressure in soft underfoot conditions.



④ **Chopper Shoes**

Other shoe options are available. Consult a Cat dealer for more information.

## SYSTEMONE SHOES



### Double Grouser Shoes

- Work best in applications that require less penetration and traction.
- Recommended for applications that require better turning capability and less ground disturbance.
- Feature two or three short grousers instead of one tall grouser.



### Center Hole Shoes

- Work best in applications where packing causes the track to tighten. They are recommended for applications with large amounts of debris that tend to pack in the track.
- Reduces extricable packing between the shoe and the bushing since they allow the sprocket to punch out dirt and debris.



# TELESCOPIC HANDLERS

## CONTENTS

Features	14-1
Specifications	14-2
Performance Data	14-6
Shipping Dimensions	14-18
Work Tools	14-19
Compatibility	14-24

### Features:

- **Intuitive control layout** enables efficient and comfortable operation.
- **Hydraulic system** enables the use of work tools requiring both intermittent and continuous auxiliary hydraulic flows.
- **Range of lift heights and load capacities** from 2500 kg (5500 lb) to 5443 kg (12,000 lb) capacity and 5.6 m (10'10") to 17 m (56'0") lift height.
- **Cat® Telehandlers offer extended reach** to easily enable material to be placed over onsite obstacles.
- **Three steering modes and tight turning circles** allow simplified movement onsite and therefore increased productivity.
- **All machines in the telehandler line feature Tier 3 compliant Cat C4.4 engines** ranging in horsepower from 84.1 kW (64 hp) on the TH255 to 106 kW (142 hp) on the TH417. The higher horsepower engines utilize electronic engine management to optimize machine performance while maintaining excellent fuel efficiency.
- **Three transmissions options are available on telehandlers.** A hydrostatic transmission is available on the TH255 to maximize machine versatility while a powershift transmission is available on the TL machines to optimize productivity and a powersychro transmission is offered on the TH machines to provide a heavy duty transmission in demanding Agricultural applications.
- **Three types of quick couplers are offered on the various telehandler models.** The TH255 offers hydraulic and manual style couplers with both a universal skid steer loader style coupler and a universal telehandler style coupler. The TL and TH lines of telehandlers offer hydraulic and manual style IT interface couplers which provide excellent work tool compatibility with older models of telehandlers and other products (for example Backhoe Loaders and Small Wheel Loaders).
- **Three auxiliary hydraulic options** are available: one auxiliary hydraulic service, two auxiliary hydraulic services and continuous hydraulic flow. These options allow maximum work tool utilization.
- **Daily maintenance** consists of only a walk-around inspection, all major components and service points are located at ground level, providing excellent ease of service.
- **Sealed bearings** require no daily or weekly greasing on engine oil, filter changes and routine lubrication are only required every 250 hours.



MODEL	TH255		TH336		TH337	
Flywheel Power (Gross)	63 kW	<b>84 hp</b>	74.5 kW	<b>100 hp</b>	74.5 kW	<b>100 hp</b>
Operating Weight	4899 kg	<b>10,800 lb</b>	6473 kg	<b>14,270 lb</b>	7073 kg	<b>15,593 lb</b>
Engine Model	<b>C4.4 DIT</b>		<b>C4.4 DITAAC</b>		<b>C4.4 DITAAC</b>	
Rated Engine RPM	<b>2200</b>		<b>2400</b>		<b>2400</b>	
No. of Cylinders	<b>4</b>		<b>4</b>		<b>4</b>	
Bore	105 mm	<b>4.13 in</b>	105 mm	<b>4.13 in</b>	105 mm	<b>4.13 in</b>
Stroke	127 mm	<b>4.99 in</b>	127 mm	<b>4.99 in</b>	127 mm	<b>4.99 in</b>
Displacement	4.4 L	<b>269 in³</b>	4.4 L	<b>269 in³</b>	4.4 L	<b>269 in³</b>
Speeds Forward:			<b>km/h</b>	<b>mph</b>	<b>km/h</b>	<b>mph</b>
1st	—		7	<b>4</b>	7	<b>4</b>
2nd	—		12	<b>7.5</b>	12	<b>7.5</b>
3rd	—		21	<b>13</b>	21	<b>13</b>
4th	—		32	<b>20</b>	32	<b>20</b>
5th	—		40	<b>25</b>	40	<b>25</b>
Speeds Reverse:						
1st	—		7	<b>4</b>	7	<b>4</b>
2nd	—		12	<b>7.5</b>	12	<b>7.5</b>
3rd	—		21	<b>13</b>	21	<b>13</b>
Turning Circle Radius						
Over Tires	3.2 m	<b>10'6"</b>	3.58 m	<b>11'9"</b>	3.70 m	<b>12'2"</b>
Over Forks	—		4.74 m	<b>15'6"</b>	4.67 m	<b>15'4"</b>
Tires	<b>12.00 x 16.5 Pneumatic</b>		<b>15.5/80 x 24 – 16PR</b>		<b>15.5/80 x 24 – 16PR</b>	
Service Refill Cap:						
Fuel Tank @ 90% fill	91 L	<b>24 U.S. gal</b>	150 L	<b>39.6 U.S. gal</b>	150 L	<b>39.6 U.S. gal</b>
Hydraulic System	64 L	<b>17 U.S. gal</b>	90 L	<b>23.7 U.S. gal</b>	90 L	<b>23.7 U.S. gal</b>



MODEL	TH406		TH407		TH414	
Flywheel Power (Gross)	74.5 kW	100 hp	74.5 kW	100 hp	74.5 kW	100 hp
Operating Weight	7200 kg	15,870 lb	7700 kg	16,980 lb	9360 kg	20,635 lb
Engine Model	C4.4 DITAAC		C4.4 DITAAC		C4.4 DITAAC	
Rated Engine RPM	2200		2200		2200	
No. of Cylinders	4		4		4	
Bore	105 mm	4.13 in	105 mm	4.13 in	105 mm	4.13 in
Stroke	127 mm	4.99 in	127 mm	4.99 in	127 mm	4.99 in
Displacement	4.4 L	269 in <sup>3</sup>	4.4 L	269 in <sup>3</sup>	4.4 L	269 in <sup>3</sup>
Speeds Forward:	km/h	mph	km/h	mph	km/h	mph
1st	7	4	7	4	7	4
2nd	12	7.5	12	7.5	12	7.5
3rd	21	13	21	13	21	13
4th	32	20	32	20	32	20
5th	40	25	40	25	—	—
Speeds Reverse:						
1st	7	4	7	4	7	4
2nd	12	7.5	12	7.5	12	7.5
3rd	21	13	21	13	21	13
Turning Circle Radius						
Over Tires	3.58 m	11'9"	3.70 m	12'2"	3.90 m	12'8"
Over Forks	4.74 m	15'6"	4.67 m	15'4"	5.40 m	17'8"
Tires	15.5/80 x 24 – 16PR		15.5/80 x 24 – 16PR		15.5/80 x 24 – 16PR	
Service Refill Cap:						
Fuel Tank @ 90% fill	150 L	39.6 U.S. gal	150 L	39.6 U.S. gal	150 L	39.6 U.S. gal
Hydraulic Tank	—	—	—	—	90 L	23.7 U.S. gal
Hydraulic System	90 L	23.7 U.S. gal	90 L	23.7 U.S. gal	—	—



MODEL	TH417		TH514		TL642	
Flywheel Power (Gross)	74.5 kW	100 hp	74.5 kW	100 hp	74.5 kW	99 hp
Operating Weight	12 000 kg	26,455 lb	11 070 kg	24,405 lb	10 470 kg	23,080 lb
Engine Model	C4.4 DITAAC		C4.4 DITAAC		C4.4 EDIT	
Rated Engine RPM	2200		2200		2400	
No. of Cylinders	4		4		4	
Bore	105 mm	4.13 in	105 mm	4.13 in	105 mm	4.13 in
Stroke	127 mm	4.99 in	127 mm	4.99 in	127 mm	4.99 in
Displacement	4.4 L	269 in <sup>3</sup>	4.4 L	269 in <sup>3</sup>	4.4 L	269 in <sup>3</sup>
Speeds Forward:	km/h	mph	km/h	mph	km/h	mph
1st	7	4	7	4	6	3.4
2nd	12	7.5	12	7.5	10	6.1
3rd	21	13	21	13	22	13.7
4th	32	20	32	20	33	20.4
Speeds Reverse:						
1st	7	4	7	4	5	3.2
2nd	12	7.5	12	7.5	10	5.9
3rd	21	13	21	13	22	13.4
Turning Circle Radius						
Over Tires	3.80 m	12'6"	3.90 m	12'2"	3.7 m	12'0"
Over Forks	5.40 m	17'9"	5.40 m	17'9"	—	—
Tires	15.5/80 x 24 – 16PR		15.5/80 x 24 – 16PR		13.00 x 24 – 12PR	
Service Refill Cap:						
Fuel Tank @ 90% fill	150 L	39.6 U.S. gal	150 L	39.6 U.S. gal	136 L	36 U.S. gal
Hydraulic Tank	90 L	23.7 U.S. gal	90 L	23.7 U.S. gal	75.7 L	20 U.S. gal
Hydraulic System	—	—	—	—	113.5 L	30 U.S. gal



<b>MODEL</b>	<b>TL943</b>		<b>TL1055</b>		<b>TL1255</b>	
Flywheel Power (Gross)	74.5 kW	<b>99 hp</b>	93.2 kW	<b>125 hp</b>	106 kW	<b>142 hp</b>
Operating Weight	11 814 kg	<b>26,050 lb</b>	15 740 kg	<b>34,700 lb</b>	16 057 kg	<b>35,400 lb</b>
Engine Model	<b>C4.4 EDIT</b>		<b>C4.4 EDITAAC</b>		<b>C4.4 EDITAAC</b>	
Rated Engine RPM	<b>2400</b>		<b>2400</b>		<b>2400</b>	
No. of Cylinders	<b>4</b>		<b>4</b>		<b>4</b>	
Bore	105 mm	<b>4.13 in</b>	105 mm	<b>4.13 in</b>	105 mm	<b>4.13 in</b>
Stroke	127 mm	<b>4.99 in</b>	127 mm	<b>4.99 in</b>	127 mm	<b>4.99 in</b>
Displacement	4.4 L	<b>269 in<sup>3</sup></b>	4.4 L	<b>269 in<sup>3</sup></b>	4.4 L	<b>269 in<sup>3</sup></b>
Speeds Forward:	km/h	<b>mph</b>	km/h	<b>mph</b>	km/h	<b>mph</b>
1st	5	<b>2.9</b>	5	<b>2.9</b>	5	<b>2.9</b>
2nd	8	<b>5.2</b>	9	<b>5.6</b>	9	<b>5.6</b>
3rd	19	<b>11.9</b>	20	<b>12.6</b>	21	<b>13</b>
4th	28	<b>17.6</b>	29	<b>18.1</b>	30	<b>18.9</b>
Speeds Reverse:						
1st	5	<b>2.9</b>	5	<b>2.9</b>	5	<b>2.9</b>
2nd	8	<b>5.1</b>	9	<b>5.6</b>	9	<b>5.6</b>
3rd	18	<b>11.5</b>	20	<b>12.6</b>	20	<b>12.6</b>
Turning Circle Radius Over Tires	3.7 m	<b>12'0"</b>	4.3 m	<b>14'0"</b>	4.3 m	<b>14'0"</b>
Tires	<b>13.00 x 24 – 12PR</b>		<b>14.00 x 24 – 12PR</b>		<b>17.50 x 25 – 15 PR</b>	
Service Refill Cap:						
Fuel Tank @ 90% fill	136 L	<b>36 U.S. gal</b>	136 L	<b>36 U.S. gal</b>	136 L	<b>36 U.S. gal</b>
Hydraulic Tank	88.2 L	<b>23.3 U.S. gal</b>	43.8 L	<b>38 U.S. gal</b>	43.8 L	<b>38 U.S. gal</b>
Hydraulic System	151.4 L	<b>40 U.S. gal</b>	227.1 L	<b>60 U.S. gal</b>	227.1 L	<b>60 U.S. gal</b>



**TH255**  
**ROW Version**

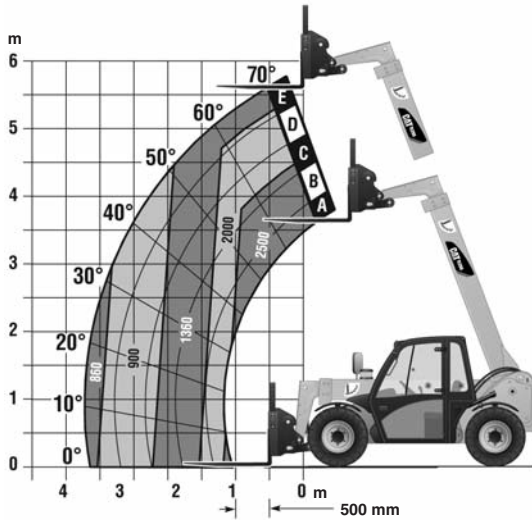

**TH255**  
**North American Version**

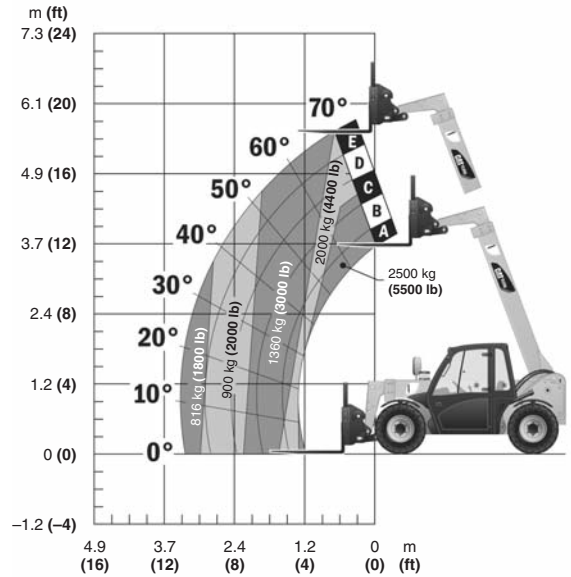

Numbers in chart measured in kilograms.

Maximum lift capacity	2500 kg	<b>5500 lb</b>
Maximum lift height	5.6 m	<b>18'4"</b>
Load at maximum height	2000 kg	<b>4400 lb</b>
Maximum forward reach	3.25 m	<b>10'10"</b>
Load at maximum reach	860 kg	<b>1896 lb</b>

Maximum lift capacity	2500 kg	<b>5500 lb</b>
Maximum lift height	5.6 m	<b>18'4"</b>
Load at maximum height	2000 kg	<b>4400 lb</b>
Maximum forward reach	3.25 m	<b>10'10"</b>
Load at maximum reach	816 kg	<b>1800 lb</b>

TH336

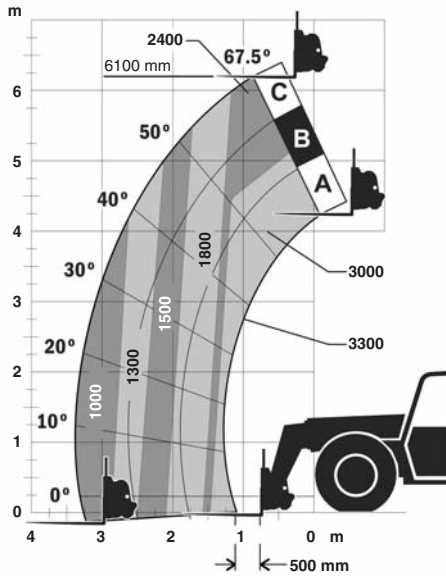

TH337

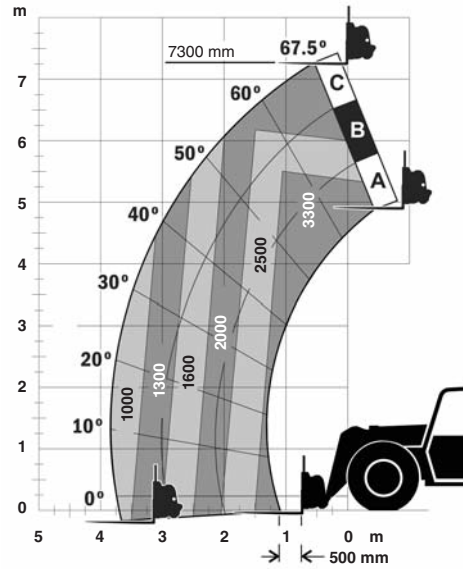

Numbers in chart measured in kilograms.

Numbers in chart measured in kilograms.

Maximum lift capacity	3300 kg	<b>7275 lb</b>
Maximum lift height	6.1 m	<b>20'0"</b>
Load at maximum height	2400 kg	<b>5291 lb</b>
Maximum forward reach	3.11 m	<b>10'2"</b>
Load at maximum reach	1000 kg	<b>2204 lb</b>

Maximum lift capacity	3300 kg	<b>7275 lb</b>
Maximum lift height	7.3 m	<b>24'0"</b>
Load at maximum height	2000 kg	<b>4409 lb</b>
Maximum forward reach	3.76 m	<b>12'4"</b>
Load at maximum reach	1000 kg	<b>2204 lb</b>

**TH406**

**North American Version**

**TH406**

**ROW Version**

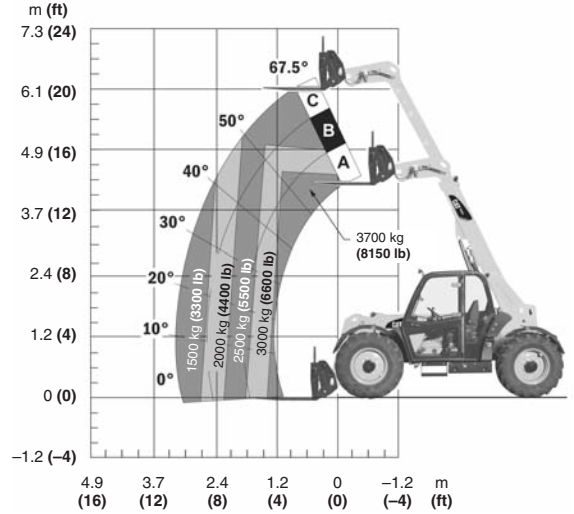
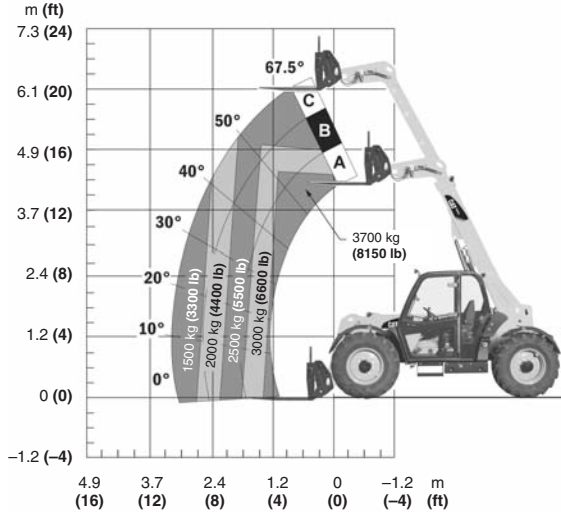

Maximum lift capacity	3700 kg	<b>8150 lb</b>
Maximum lift height	6.1 m	<b>20'0"</b>
Load at maximum height	2500 kg	<b>5511 lb</b>
Maximum forward reach	3.11 m	<b>10'2"</b>
Load at maximum reach	1500 kg	<b>3300 lb</b>

Maximum lift capacity	3700 kg	<b>8150 lb</b>
Maximum lift height	6.1 m	<b>20'0"</b>
Load at maximum height	2500 kg	<b>5511 lb</b>
Maximum forward reach	3.11 m	<b>10'2"</b>
Load at maximum reach	1500 kg	<b>3300 lb</b>

**TH407**  
**ROW Version**

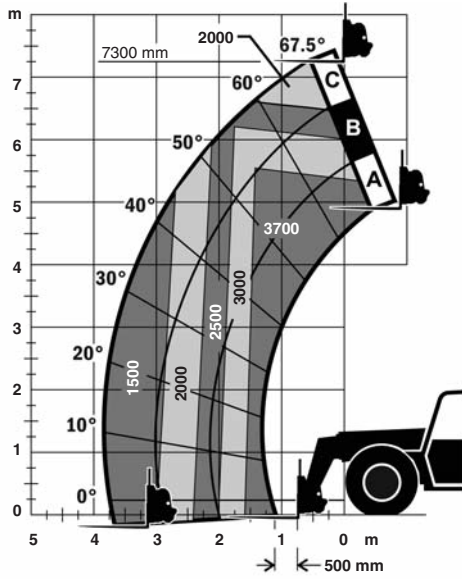

**TH407**  
**North American Version**

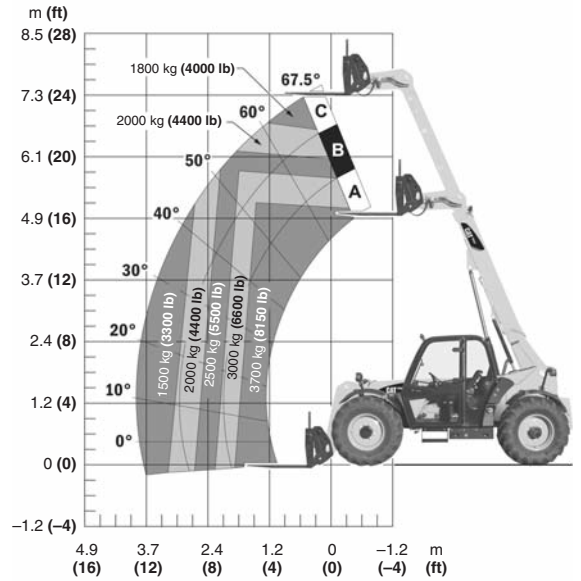

Numbers in chart measured in kilograms.

Maximum lift capacity	3700 kg	<b>8150 lb</b>
Maximum lift height	7.3 m	<b>24'0"</b>
Load at maximum height	2000 kg	<b>4410 lb</b>
Maximum forward reach	3.76 m	<b>12'4"</b>
Load at maximum reach	1500 kg	<b>3300 lb</b>

Maximum lift capacity	3700 kg	<b>8150 lb</b>
Maximum lift height	7.3 m	<b>24'0"</b>
Load at maximum height	1800 kg	<b>4000 lb</b>
Maximum forward reach	3.76 m	<b>12'4"</b>
Load at maximum reach	1500 kg	<b>3300 lb</b>

**TH414**  
**Stabilizers Up**

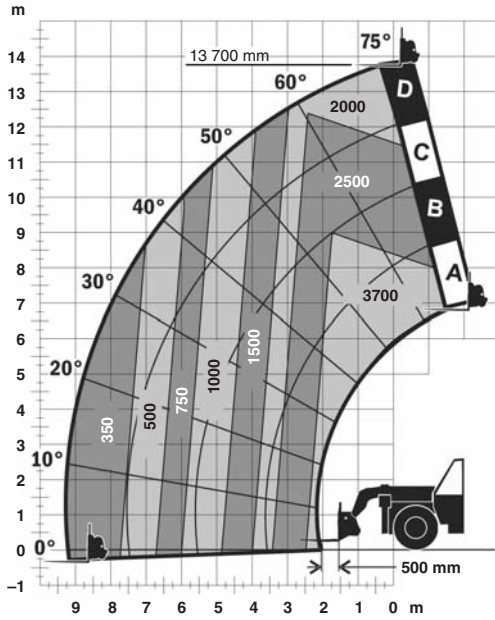

Numbers in chart measured in kilograms.

Maximum lift capacity	3700 kg	<b>8150 lb</b>
Maximum lift height	13.7 m	<b>44'11"</b>
Load at maximum height	2000 kg	<b>4410 lb</b>
Maximum forward reach	9.23 m	<b>30'3"</b>
Load at maximum reach	350 kg	<b>771 lb</b>

**TH414**  
**Stabilizers Down**

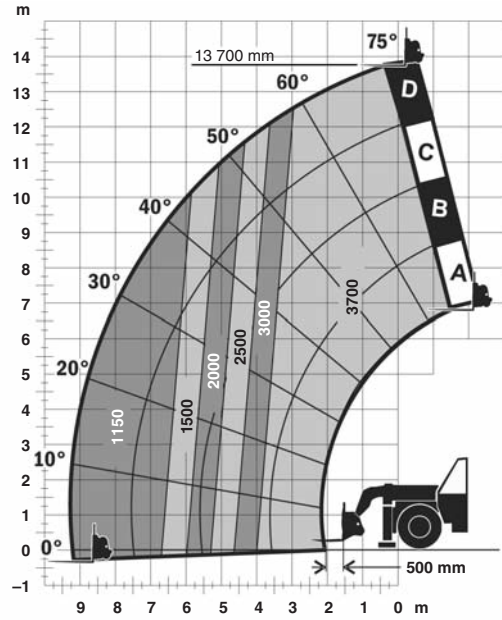

Numbers in chart measured in kilograms.

Maximum lift capacity	3700 kg	<b>8150 lb</b>
Maximum lift height	13.7 m	<b>44'11"</b>
Load at maximum height	3700 kg	<b>8150 lb</b>
Maximum forward reach	9.23 m	<b>30'3"</b>
Load at maximum reach	1150 kg	<b>2535 lb</b>

**TH417**  
**Stabilizers Up**

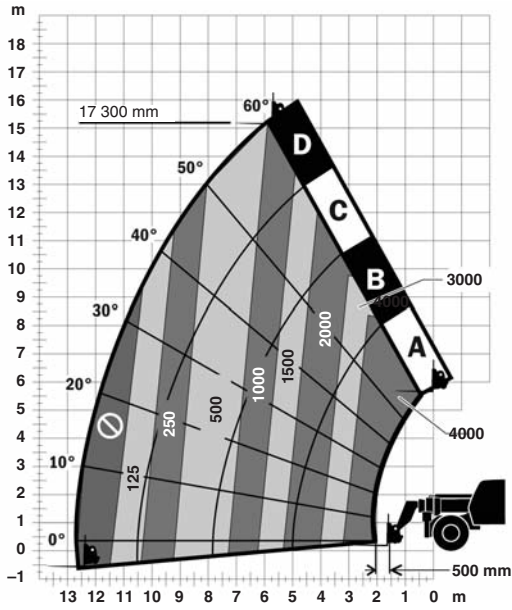

Numbers in chart measured in kilograms.

Maximum lift capacity	4000 kg	<b>8820 lb</b>
Maximum lift height	17.0 m	<b>55'9"</b>
Load at maximum height	1000 kg	<b>2200 lb</b>
Maximum forward reach	12.7 m	<b>41'8"</b>
Load at maximum reach	0 kg	<b>0 lb</b>

**TH417**  
**Stabilizers Down**

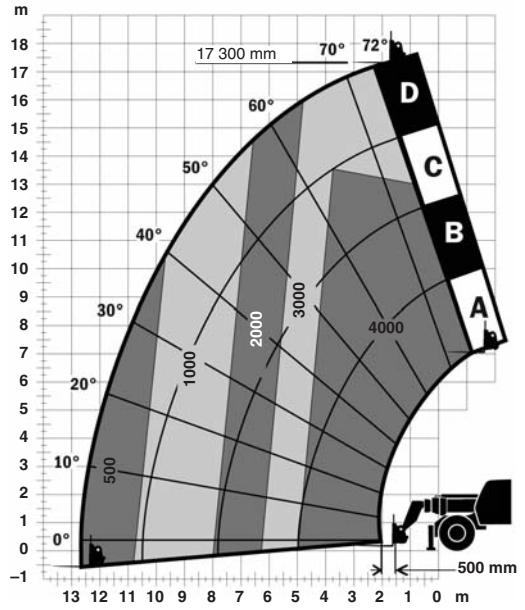

Numbers in chart measured in kilograms.

Maximum lift capacity	4000 kg	<b>8820 lb</b>
Maximum lift height	17.0 m	<b>55'9"</b>
Load at maximum height	3000 kg	<b>6610 lb</b>
Maximum forward reach	12.7 m	<b>41'8"</b>
Load at maximum reach	500 kg	<b>1100 lb</b>

**TH514**  
**Stabilizers Up**

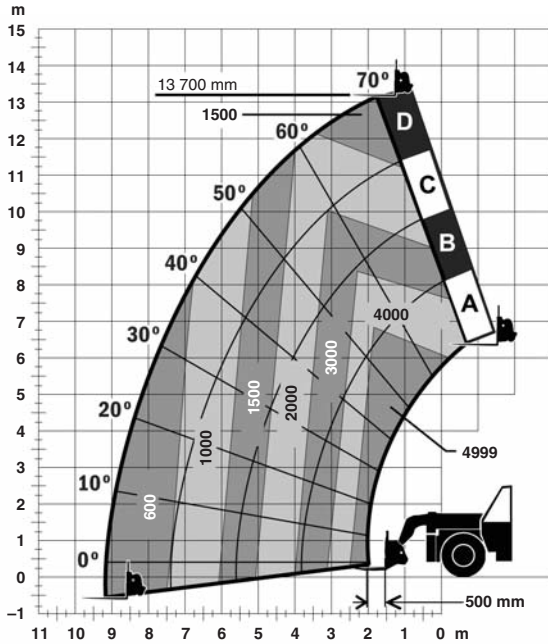

Numbers in chart measured in kilograms.

Maximum lift capacity	4999 kg	<b>11,020 lb</b>
Maximum lift height	13.7 m	<b>44'11"</b>
Load at maximum height	1500 kg	<b>3306 lb</b>
Maximum forward reach	9.22 m	<b>30'3"</b>
Load at maximum reach	600 kg	<b>1322 lb</b>

**TH514**  
**Stabilizers Down**

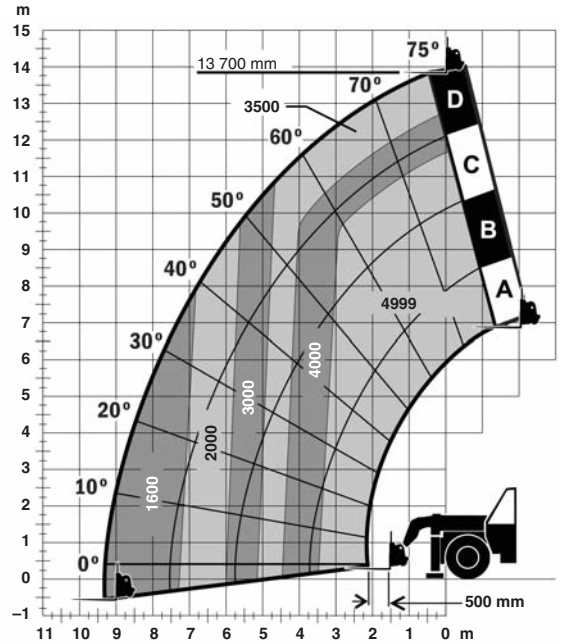

Numbers in chart measured in kilograms.

Maximum lift capacity	4999 kg	<b>11,020 lb</b>
Maximum lift height	13.7 m	<b>44'11"</b>
Load at maximum height	3500 kg	<b>7716 lb</b>
Maximum forward reach	9.22 m	<b>30'3"</b>
Load at maximum reach	1600 kg	<b>3527 lb</b>

**TL642**  
**No Stabilizers**

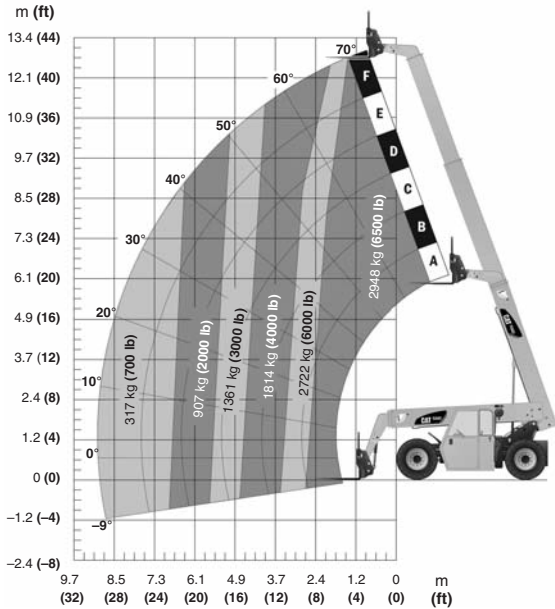

**TL642**  
**Stabilizers Up**

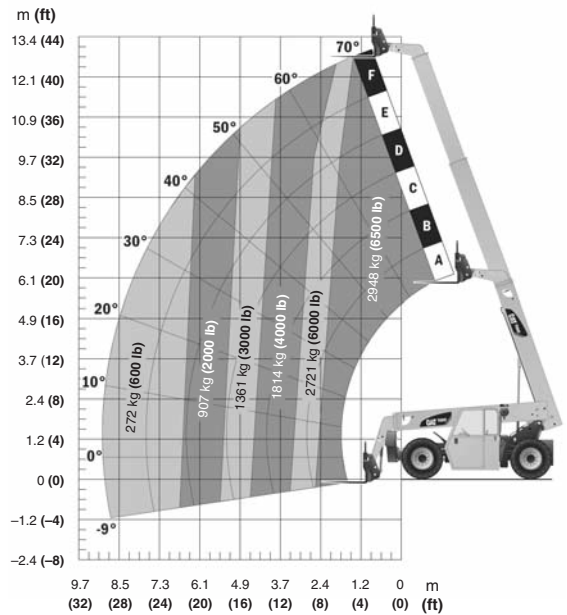

Maximum lift capacity	2948 kg	<b>6500 lb</b>
Maximum lift height	12.8 m	<b>42'0"</b>
Load at maximum height	2948 kg	<b>6500 lb</b>
Maximum forward reach	9.1 m	<b>30'0"</b>
Load at maximum reach	317 kg	<b>700 lb</b>

Maximum lift capacity	2948 kg	<b>6500 lb</b>
Maximum lift height	12.8 m	<b>42'0"</b>
Load at maximum height	2948 kg	<b>6500 lb</b>
Maximum forward reach	9.1 m	<b>30'0"</b>
Load at maximum reach	272 kg	<b>600 lb</b>



**TL642**

**Stabilizers Down**

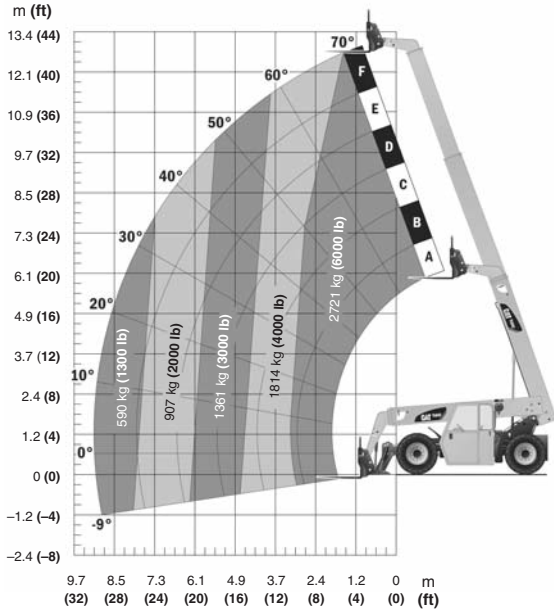

**TL943**

**No Stabilizers**

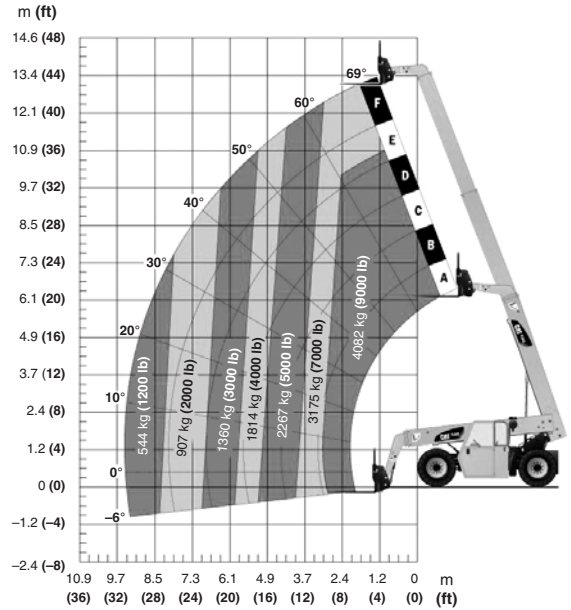

Maximum lift capacity	2948 kg	<b>6500 lb</b>
Maximum lift height	12.8 m	<b>42'0"</b>
Load at maximum height	2948 kg	<b>6500 lb</b>
Maximum forward reach	9.1 m	<b>30'0"</b>
Load at maximum reach	771 kg	<b>1700 lb</b>

Maximum lift capacity	4082 kg	<b>9000 lb</b>
Maximum lift height	13.1 m	<b>43'0"</b>
Load at maximum height	3175 kg	<b>7000 lb</b>
Maximum forward reach	9.6 m	<b>31'5"</b>
Load at maximum reach	544 kg	<b>1200 lb</b>

**TL943**  
**Stabilizers Up**

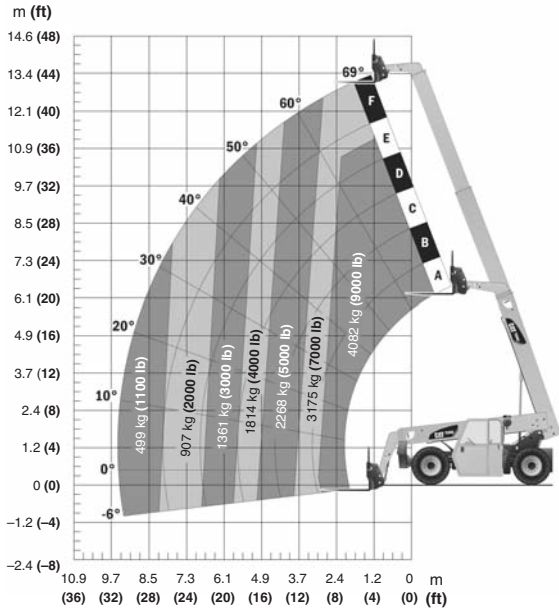

**TL943**  
**Stabilizers Down**

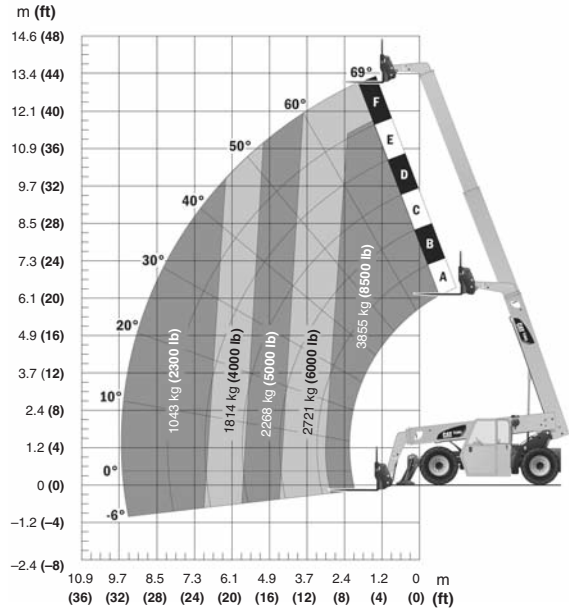

Maximum lift capacity	4082 kg	<b>9000 lb</b>
Maximum lift height	13.1 m	<b>43'0"</b>
Load at maximum height	3175 kg	<b>7000 lb</b>
Maximum forward reach	9.6 m	<b>31'5"</b>
Load at maximum reach	499 kg	<b>1100 lb</b>

Maximum lift capacity	4082 kg	<b>9000 lb</b>
Maximum lift height	13.1 m	<b>43'0"</b>
Load at maximum height	3175 kg	<b>7000 lb</b>
Maximum forward reach	9.6 m	<b>31'5"</b>
Load at maximum reach	1225 kg	<b>2700 lb</b>

**TL1055**  
**Stabilizers Up**

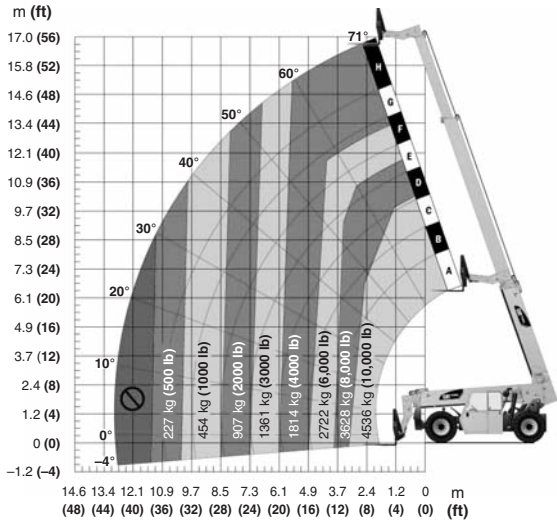

**TL1055**  
**Stabilizers Down**

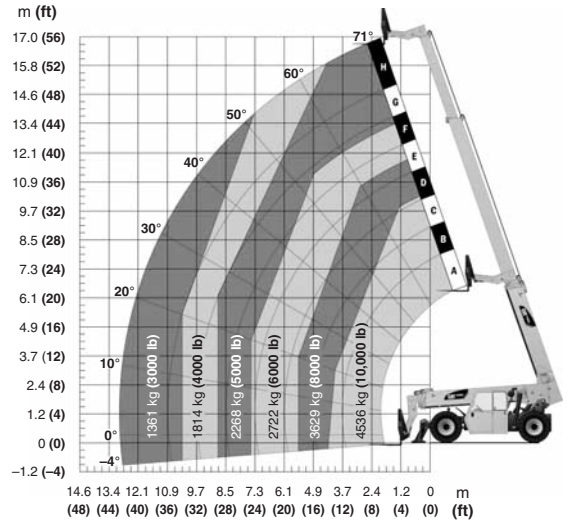

Maximum lift capacity	4536 kg	<b>10,000 lb</b>
Maximum lift height	16.8 m	<b>55'0"</b>
Load at maximum height	1814 kg	<b>4000 lb</b>
Maximum forward reach	13.0 m	<b>42'6"</b>
Load at maximum reach	0 kg	<b>0 lb</b>

Maximum lift capacity	4536 kg	<b>10,000 lb</b>
Maximum lift height	16.8 m	<b>55'1"</b>
Load at maximum height	2268 kg	<b>5000 lb</b>
Maximum forward reach	13.0 m	<b>42'6"</b>
Load at maximum reach	1361 kg	<b>3000 lb</b>

**TL1255**  
**Stabilizers Up**

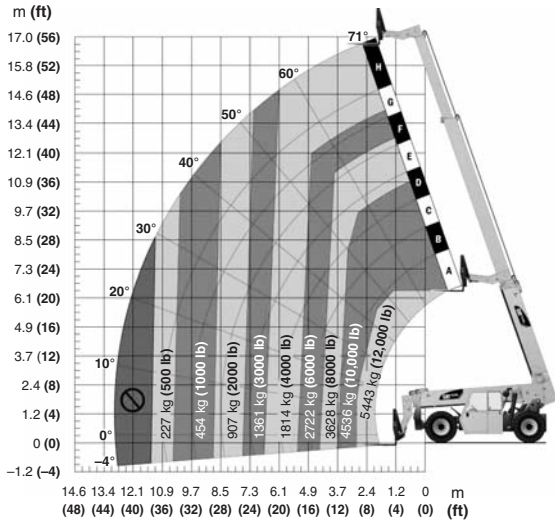

**TL1255**  
**Stabilizers Down**

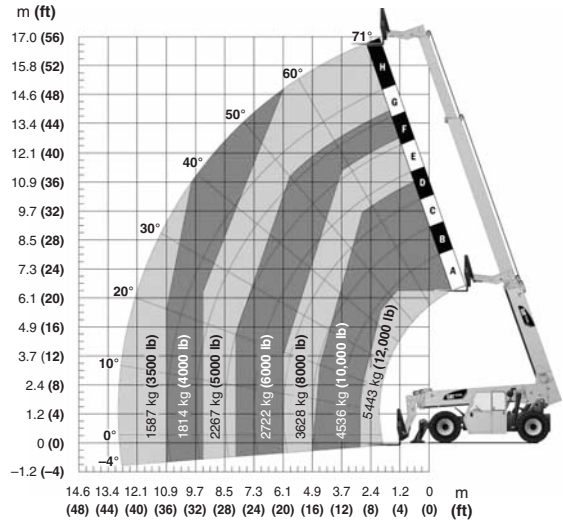

Maximum lift capacity	5443 kg	<b>12,000 lb</b>
Maximum lift height	16.6 m	<b>54'5"</b>
Load at maximum height	1814 kg	<b>4000 lb</b>
Maximum forward reach	13.0 m	<b>42'6"</b>
Load at maximum reach	0 kg	<b>0 lb</b>

Maximum lift capacity	5443 kg	<b>12,000 lb</b>
Maximum lift height	16.6 m	<b>54'5"</b>
Load at maximum height	2267 kg	<b>5000 lb</b>
Maximum forward reach	13.0 m	<b>42'6"</b>
Load at maximum reach	1588 kg	<b>3500 lb</b>

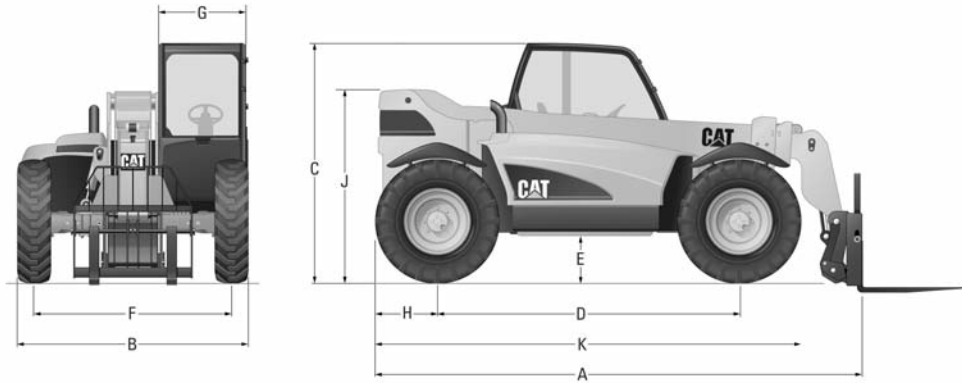

**Dimensions (approx.)**

Model	TH255		TH336		TH337		TH406	
	mm	ft	mm	ft	mm	ft	mm	ft
A) Length to fork face	3658	12'0"	4621	15'2"	4866	16'0"	4621	15'2"
B) Width	1816	5'10"	2400	7'10"	2400	7'10"	2400	7'9"
C) Height	1920	6'3"	2323	7'7"	2385	7'10"	2323	7'6"
D) Wheel base	2286	7'5"	2950	9'8"	3050	10'0"	2950	9'7"
E) Ground clearance	279	11"	430	1'5"	430	1'5"	430	1'5"
F) Wheel track	—		1988	6'6"	1988	6'6"	1988	6'6"
G) Cab width (inside)	864	2'10"	880	2'11"	880	2'11"	880	2'11"

Model	TH407		TH414		TH417		TH514	
	mm	ft	mm	ft	mm	ft	mm	ft
A) Length to fork face	5153	16'11"	6325	20'9"	6612	21'8"	6325	20'9"
B) Width	2400	7'9"	2440	7'11"	2440	8'0"	2480	8'2"
C) Height	2385	7'8"	2592	8'6"	2667	8'9"	2592	8'6"
D) Wheel base	3050	10'0"	3200	10'6"	3200	10'6"	3200	10'6"
E) Ground clearance	441	1'4"	469	1'6"	458	1'6"	458	1'6"
F) Wheel track	1988	6'6"	2030	6'8"	2078	6'10"	2030	6'8"
G) Cab width (inside)	880	2'11"	880	2'11"	880	2'11"	880	2'11"

Model	TL642		TL943		TL1055		TL1255	
	mm	ft	mm	ft	mm	ft	mm	ft
A) Length to fork face	5629	18'5"	6248	20'5"	6325	20'8"	6325	20'8"
B) Width	2426	8'0"	2426	8'0"	2565	8'4"	2565	8'4"
C) Height	2388	7'8"	2426	8'0"	2565	8'4"	2565	8'4"
D) Wheel base	3251	10'7"	3353	11'0"	3658	12'0"	3658	12'0"
E) Ground clearance	417	1'4"	483	1'7"	457	1'6"	483	1'7"
F) Wheel track	2108	6'9"	2108	6'9"	2159	7'1"	2159	7'1"
G) Cab width (inside)	940	3'1"	940	3'1"	940	3'1"	940	3'1"

All carriages are bar type with load backrest to support bulky loads.  
Widespread carriages provide added stability for lifting larger loads.  
Standard and widespread carriages are also available in rotating mode.

**Carriage Type**

<b>Model</b>	<b>Standard</b>		<b>Standard — Framers</b>		<b>Rotate</b>		<b>Rotate — Framers</b>		<b>Side Shift</b>	
<b>TH255</b>										
Weight w/1220 mm (48") forks	261 kg	<b>575 lb</b>	367 kg	<b>810 lb</b>	—	—	—	—	—	—
Width	1219 mm	<b>4'0"</b>	1219 mm	<b>4'0"</b>	1219 mm	<b>4'0"</b>	—	—	—	—
Height	1118 mm	<b>3'7"</b>	1118 mm	<b>3'7"</b>	1168 mm	<b>3'10"</b>	—	—	—	—
Max. fork spread	1067 mm	<b>3'5"</b>	1092 mm	<b>3'6"</b>	1067 mm	<b>3'5"</b>	—	—	—	—
Floating fork movement	76 mm	<b>3"</b>	76 mm	<b>3"</b>	76 mm	<b>3"</b>	—	—	—	—
<b>TH336 through TH417</b>										
Weight w/1220 mm (48") fork	272 kg	<b>600 lb</b>	336 kg	<b>740 kg</b>	408 kg	<b>900 lb</b>	492 kg	<b>1084 lb</b>	422 kg	<b>930 lb</b>
Width	1224 mm	<b>4'0"</b>	1880 mm	<b>6'2"</b>	1224 mm	<b>4'0"</b>	1880 mm	<b>6'2"</b>	1230 mm	<b>4'0"</b>
Height	1039 mm	<b>3'5"</b>	1039 mm	<b>3'5"</b>	1216 mm	<b>4'0"</b>	1216 mm	<b>4'0"</b>	1135 mm	<b>3'8"</b>
Max. fork spread	1200 mm	<b>3'11"</b>	1856 mm	<b>6'1"</b>	1200 mm	<b>3'11"</b>	1856 mm	<b>6'1"</b>	1200 mm	<b>3'11"</b>
Floating fork movement	70 mm	<b>3"</b>	70 mm	<b>3"</b>	70 mm	<b>3"</b>	70 mm	<b>3"</b>	70 mm	<b>3"</b>
Rotation	—	—	—	—	<b>11.5°</b>	<b>11.5°</b>	<b>11.5°</b>	<b>11.5°</b>	—	—
<b>TH514</b>										
Weight w/1220 mm (48") fork	303 kg	<b>600 lb</b>	336 kg	<b>740 lb</b>	408 kg	<b>900 lb</b>	492 kg	<b>1084 lb</b>	422 kg	<b>930 lb</b>
Width	1224 mm	<b>4'0"</b>	1880 mm	<b>6'2"</b>	1224 mm	<b>4'0"</b>	1880 mm	<b>6'2"</b>	1230 mm	<b>4'0"</b>
Height	1039 mm	<b>3'5"</b>	1039 mm	<b>3'5"</b>	1216 mm	<b>4'0"</b>	1216 mm	<b>4'0"</b>	1135 mm	<b>3'8"</b>
Max. fork spread	1200 mm	<b>3'11"</b>	1856 mm	<b>6'1"</b>	1200 mm	<b>3'11"</b>	1856 mm	<b>6'1"</b>	1200 mm	<b>3'11"</b>
Floating fork movement	70 mm	<b>3"</b>	70 mm	<b>3"</b>	70 mm	<b>3"</b>	70 mm	<b>3"</b>	70 mm	<b>3"</b>
Rotation	—	—	—	—	<b>11.5°</b>	<b>11.5°</b>	<b>11.5°</b>	<b>11.5°</b>	—	—
<b>TH580B</b>										
Weight w/1220 mm (48") fork	303 kg	<b>600 lb</b>	336 kg	<b>740 lb</b>	408 kg	<b>900 lb</b>	492 kg	<b>1084 lb</b>	422 kg	<b>930 lb</b>
Width	1224 mm	<b>4'0"</b>	1880 mm	<b>6'2"</b>	1224 mm	<b>4'0"</b>	1880 mm	<b>6'2"</b>	1230 mm	<b>4'0"</b>
Height	1039 mm	<b>3'5"</b>	1039 mm	<b>3'5"</b>	1216 mm	<b>4'0"</b>	1216 mm	<b>4'0"</b>	1135 mm	<b>3'8"</b>
Max. fork spread	1200 mm	<b>3'11"</b>	1856 mm	<b>6'1"</b>	1200 mm	<b>3'11"</b>	1856 mm	<b>6'1"</b>	1200 mm	<b>3'11"</b>
Floating fork movement	70 mm	<b>3"</b>	70 mm	<b>3"</b>	70 mm	<b>3"</b>	70 mm	<b>3"</b>	70 mm	<b>3"</b>
Rotation	—	—	—	—	<b>11.5°</b>	<b>11.5°</b>	<b>11.5°</b>	<b>11.5°</b>	—	—
<b>Capacities:</b>										
<b>TH255</b>	2500 kg	<b>5500 lb</b>	—	—	—	—	—	—	—	—
<b>TH406</b>	3700 kg	<b>8157 lb</b>	—	—	—	—	—	—	—	—
<b>TH407</b>	3700 kg	<b>8157 lb</b>	—	—	—	—	—	—	—	—
<b>TH360B</b>	3000 kg	<b>6600 lb</b>	2830 kg	<b>6240 lb</b>	2780 kg	<b>6120 lb</b>	2780 kg	<b>6120 lb</b>	2690 kg	<b>5930 lb</b>
<b>TH560B</b>	5000 kg	<b>11,000 lb</b>	4850 kg	<b>10,690 lb</b>	4800 kg	<b>10,580 lb</b>	4700 kg	<b>10,360 lb</b>	4700 kg	<b>10,360 lb</b>
<b>TH580B</b>	5000 kg	<b>11,000 lb</b>	4900 kg	<b>10,800 lb</b>	4700 kg	<b>10,360 lb</b>	4600 kg	<b>10,140 lb</b>	4600 kg	<b>10,140 lb</b>

Model	Carriage Type					
	Standard		Standard — Framers		Rotate 1270 mm (50")	
<b>TL642, TL943, TL1055, TL1255</b>						
Weight* w/1220 mm (48") forks (51 mm × 51 mm/2" × 2")	295 kg	<b>650 lb</b>	363 kg	<b>800 lb</b>	454 kg	<b>1000 lb</b>
Width**	1422 mm	<b>56"</b>	1981 mm	<b>78"</b>	1422 mm	<b>56"</b>
Height**	1270 mm	<b>50"</b>	1067 mm	<b>42"</b>	1270 mm	<b>50"</b>
Max. fork spread (out to out)	1270 mm	<b>50"</b>	1829 mm	<b>72"</b>	1270 mm	<b>50"</b>
Floating fork movement	98 mm	<b>3.9"</b>	98 mm	<b>3.9"</b>	98 mm	<b>3.9"</b>
Rotation	—		—		±10°	

\*Weights are for information purposes only. Refer to applicable load charts for specific data.

\*\*Dimensions are approximate.

Model	Carriage Type					
	Rotate — Framers 1830 mm (72")		Side Shift ±102 mm (±4")		Swing	
<b>TL642, TL943, TL1055, TL1255</b>						
Weight* w/1220 mm (48") forks (51 mm × 51 mm/2" × 2")	522 kg	<b>1150 lb</b>	363 kg	<b>800 lb</b>	975 kg	<b>2150 lb</b>
Width**	1981 mm	<b>78"</b>	1245 mm	<b>49"</b>	1772 mm	<b>69.75"</b>
Height**	1067 mm	<b>42"</b>	1041 mm	<b>41"</b>	1194 mm	<b>47"</b>
Max. fork spread (out to out)	1829 mm	<b>72"</b>	1162 mm	<b>45.75"</b>	1854 mm	<b>73"</b>
Floating fork movement	98 mm	<b>3.9"</b>	51 mm	<b>2"</b>	76 mm	<b>3"</b>
Rotation	±10°		—		100°	

\*Weights are for information purposes only. Refer to applicable load charts for specific data.

\*\*Dimensions are approximate.

All carriages are bar type with load backrest to support bulky loads.  
Widespread carriages provide added stability for lifting larger loads.  
Standard and widespread carriages are also available in rotating mode.

Non-U.S. Models					
Fork Type					
Pallet			Block		
Model	Forks/Set	Size	Model	Forks/Set	Size
TH255	2	45 × 100 × 1070 mm 2" × 4" × 42"	TH336 through TH417	2	50 × 50 × 1220 mm 2" × 2" × 48"
	2	50 × 100 × 1525 mm 2" × 4" × 60"			
	2	50 × 100 × 1200 mm 2" × 4" × 47"			
	2	50 × 120 × 1200 mm 2" × 5" × 47"			
TH336, TH406, TH337, TH407, TH414, TH417, TH514	2	45 × 100 × 1070 mm 2" × 4" × 42"			
	2	50 × 100 × 1525 mm 2" × 4" × 60"			
	2	50 × 100 × 1200 mm 2" × 4" × 47"			
	2	50 × 120 × 1200 mm 2" × 5" × 47"			
TH514	2	60 × 100 × 1200 mm 2.36" × 4" × 47"			



North American Models

Fork Type

Pallet			Block		
Model	Forks/Set	Size	Model	Forks/Set	Size
TH255	2	51 × 102 × 1219 mm 2" × 4" × 48"	TH255	2	51 × 51 × 1219 mm 2" × 2" × 48"
	2	38 × 152 × 1524 mm 1.5" × 6" × 60"			
TH406 and TH407	2	50 × 100 × 1525 mm 2" × 4" × 60"	TH406 and TH407	2	51 × 51 × 1219 mm 2" × 2" × 48"
	2	50 × 120 × 1200 mm 2" × 4.7" × 47"			
TL642, TL943, TL1055, TL1255	2	60 × 102 × 1219 mm 2.36" × 4" × 48"	TL642 through TL1255	2	51 × 51 × 1219 mm 2" × 2" × 48"
	2	60 × 152 × 1524 mm 2.36" × 6" × 60"			
	2	51 × 152 × 1829 mm 2" × 6" × 72"			
	2	44 × 178 × 1524 mm 1.75" × 7" × 60"			

**Work Tools**

<b>Truss Boom</b>		
Length	4000 mm	<b>13'0"</b>
Weight	200 kg	<b>441 lb</b>
Capacity	500 kg	<b>1100 lb</b>
<b>Lifting Hook</b>		
Weight	98 kg	<b>216 lb</b>
Capacity	5000 kg	<b>11,020 lb</b>
<b>1.0 m<sup>3</sup> (1.3 yd<sup>3</sup>) GP Bucket</b>		
Capacity	1.0 m <sup>3</sup>	<b>1.3 yd<sup>3</sup></b>
Width	2406 mm	<b>7'11"</b>
Weight	544 kg	<b>1200 lb</b>
<b>1.0 m<sup>3</sup> (1.3 yd<sup>3</sup>) MP Bucket</b>		
Capacity	1.0 m <sup>3</sup>	<b>1.3 yd<sup>3</sup></b>
Width	2406 mm	<b>7'1"</b>
Weight	740 kg	<b>1631 lb</b>
<b>1.5 m<sup>3</sup> (2 yd<sup>3</sup>) Rehandling Bucket</b>		
Capacity	1.5 m <sup>3</sup>	<b>2 yd<sup>3</sup></b>
Width	2406 mm	<b>7'1"</b>
Weight	548 kg	<b>1208 lb</b>
<b>LM Bucket</b>		
<b>1.3 m<sup>3</sup> (1.7 yd<sup>3</sup>)</b>		
Capacity	1.3 m <sup>3</sup>	<b>1.7 yd<sup>3</sup></b>
Width	1829 mm	<b>6'0"</b>
Weight	348 kg	<b>768 lb</b>
<b>2.0 m<sup>3</sup> (2.6 yd<sup>3</sup>)</b>		
Capacity	2.0 m <sup>3</sup>	<b>2.6 yd<sup>3</sup></b>
Width	2500 mm	<b>8'2"</b>
Weight	566 kg	<b>1248 lb</b>
<b>2.5 m<sup>3</sup> (3.25 yd<sup>3</sup>)</b>		
Capacity	2.5 m <sup>3</sup>	<b>3.25 yd<sup>3</sup></b>
Width	2500 mm	<b>8'2"</b>
Weight	628 kg	<b>1384 lb</b>
<b>3.0 m<sup>3</sup> (3.9 yd<sup>3</sup>)</b>		
Capacity	3.0 m <sup>3</sup>	<b>3.9 yd<sup>3</sup></b>
Width	2700 mm	<b>8'10"</b>
Weight	705 kg	<b>1553 lb</b>

<b>HD Manure Fork</b>		
Capacity	1.9 m <sup>3</sup>	<b>2.5 yd<sup>3</sup></b>
Width	2290 mm	<b>7'6"</b>
Weight	560 kg	<b>1234 lb</b>
Tine length	1060 mm	<b>3'6"</b>
No. of tines	<b>9</b>	
<b>HD Manure Fork + Grab</b>		
Capacity	1.9 m <sup>3</sup>	<b>2.5 yd<sup>3</sup></b>
Width	2290 mm	<b>7'6"</b>
Weight	750 kg	<b>1653 lb</b>
Tine length	1060 mm	<b>3'6"</b>
No. of tines	<b>9</b>	
<b>HD Manure Fork, Grab + Pusher</b>		
Capacity	1.7 m <sup>3</sup>	<b>2.26 yd<sup>3</sup></b>
Width	2290 mm	<b>7'6"</b>
Weight	978 kg	<b>2155 lb</b>
Tine length	1060 mm	<b>3'6"</b>
No. of tines	<b>9</b>	
<b>Std. Duty Manure Fork + Grab</b>		
Capacity	1.8 m <sup>3</sup>	<b>2.34 yd<sup>3</sup></b>
Width	2290 mm	<b>7'6"</b>
Weight	560 kg	<b>1234 lb</b>
Tine length	1060 mm	<b>3'6"</b>
No. of tines	<b>9</b>	
<b>Grapple Multi Bucket</b>		
Capacity	0.85 m <sup>3</sup>	<b>1.1 yd<sup>3</sup></b>
Width	2330 mm	<b>7'8"</b>
Weight	765 kg	<b>1686 lb</b>
<b>Bale Handler</b>		
Width	1220 mm	<b>4'0"</b>
Weight	411 kg	<b>906 lb</b>
Tine length	600 mm	<b>2'0"</b>
No. of tines	<b>10</b>	

	TH255	TH336	TH337	TH406	TH407	TH414	TH417	TH514	TL642	TL943	TL1055	TL1255
Truss Boom	N/A	Yes	Yes	Yes	Yes	Yes	Yes	Yes	Yes	Yes	Yes	Yes
Lifting Hook	Yes	Yes	Yes	Yes	Yes	Yes	Yes	Yes	Yes	Yes	Yes	Yes
Rehandling Bucket 1.5 m <sup>3</sup> (2 yd <sup>3</sup> )	N/A	Yes	Yes	Yes	Yes	Yes	Yes	N/A	Yes	Yes	Yes	Yes
Light Material Bucket:												
2.0 m <sup>3</sup> (2.6 yd <sup>3</sup> )	Yes	Yes	Yes	Yes	Yes	N/A	N/A	N/A	N/A	N/A	N/A	N/A
2.5 m <sup>3</sup> (3.25 yd <sup>3</sup> )	N/A	Yes	Yes	Yes	Yes	N/A	N/A	N/A	N/A	N/A	N/A	N/A
3.0 m <sup>3</sup> (3.9 yd <sup>3</sup> )	N/A	Yes	Yes	Yes	Yes	N/A	N/A	N/A	N/A	N/A	N/A	N/A
HD Manure Fork	N/A	Yes	Yes	Yes	Yes	N/A	N/A	N/A	N/A	N/A	N/A	N/A
HD Manure Fork + Grab	N/A	Yes	Yes	Yes	Yes	N/A	N/A	N/A	N/A	N/A	N/A	N/A
HD Manure Fork + Grab + Pusher	N/A	Yes	Yes	Yes	Yes	N/A	N/A	N/A	N/A	N/A	N/A	N/A
LD Manure Fork + Grab	N/A	Yes	Yes	Yes	Yes	N/A	N/A	N/A	N/A	N/A	N/A	N/A
Grapple Multi Bucket	Yes	Yes	Yes	Yes	Yes	N/A	N/A	N/A	N/A	N/A	N/A	N/A
Bale Handler	N/A	Yes	Yes	Yes	Yes	N/A	N/A	N/A	N/A	N/A	N/A	N/A
Standard Carriage	Yes	Yes	Yes	Yes	Yes	Yes	Yes	Yes	Yes	Yes	Yes	Yes
Standard Carriage — (Framers)	N/A	Yes	Yes	Yes	Yes	Yes	Yes	Yes	Yes	Yes	Yes	Yes
Rotate Carriage	Yes	Yes	Yes	Yes	Yes	Yes	Yes	Yes	Yes	Yes	Yes	Yes
Rotate Carriage — (Framers)	N/A	Yes	Yes	Yes	Yes	Yes	Yes	Yes	Yes	Yes	Yes	Yes
Sideshift Carriage	Yes	Yes	Yes	Yes	Yes	Yes	Yes	Yes	Yes	Yes	Yes	Yes
Material Handling Arm	N/A	Yes	Yes	Yes	Yes	Yes	Yes	Yes	Yes	Yes	Yes	N/A
Pallet Fork — 60 mm (2.4") diameter:												
1070 mm (42") long	N/A	Yes	Yes	Yes	Yes	Yes	Yes	Yes	Yes	Yes	Yes	Yes
1220 mm (48") long	N/A	Yes	Yes	Yes	Yes	Yes	Yes	Yes	Yes	Yes	Yes	Yes
1525 mm (60") long	N/A	Yes	Yes	Yes	Yes	Yes	Yes	Yes	N/A	Yes	Yes	Yes
Extended shank												
Pallet Fork — 51 mm (2") diameter:												
1070 mm (42") long	N/A	N/A	N/A	N/A	N/A	N/A	N/A	N/A	Yes	Yes	Yes	Yes
1220 mm (48") long	Yes	N/A	N/A	N/A	N/A	N/A	N/A	N/A	Yes	Yes	Yes	Yes
1525 mm (60") long	N/A	N/A	N/A	N/A	N/A	N/A	N/A	N/A	Yes	Yes	Yes	Yes
Extended shank												
Block Fork — 60 mm (2.4") diameter	N/A	Yes	Yes	Yes	Yes	Yes	Yes	Yes	Yes	Yes	Yes	Yes
Block Fork — 51 mm (2") diameter	Yes	N/A	N/A	N/A	N/A	N/A	N/A	N/A	Yes	Yes	Yes	Yes
General Purpose Bucket:												
1.0 m <sup>3</sup> (1.3 yd <sup>3</sup> )	N/A	Yes	Yes	Yes	Yes	Yes	Yes	Yes	Yes	Yes	Yes	Yes
0.76 m <sup>3</sup> (1.0 yd <sup>3</sup> )	Yes	N/A	N/A	N/A	N/A	N/A	N/A	N/A	N/A	N/A	N/A	N/A
Material Handling Bucket:												
1.5 m <sup>3</sup> (1.96 yd <sup>3</sup> )	N/A	Yes	Yes	Yes	Yes	Yes	N/A	N/A	Yes	Yes	Yes	Yes
Multi-Purpose Bucket:												
1.0 m <sup>3</sup> (1.3 yd <sup>3</sup> )	N/A	Yes	Yes	Yes	Yes	Yes	N/A	N/A	Yes	Yes	Yes	Yes
0.76 m <sup>3</sup> (1.0 yd <sup>3</sup> )	Yes	N/A	N/A	N/A	N/A	N/A	N/A	N/A	N/A	N/A	N/A	N/A

# PAVING PRODUCTS

## CONTENTS

### COLD PLANERS

Sustainability	15-1
Features	15-1
Specifications	15-2
Production Estimating	15-3
Machine Selection	15-5
Cold Planing Fundamentals	15-5
Types of Cutting Rotors	15-6
Applications	15-7
Cold Planer Use by Project Type	15-8

### ROTARY MIXERS

Sustainability	15-9
Features	15-9
Specifications	15-10
Optional Equipment	15-10
Production Estimating	15-11
Weight of Materials	15-12
Stabilization/Reclamation Production	15-12

### ASPHALT PAVERS

Sustainability	15-13
Features	15-13
Specifications	15-14
Barber-Greene	15-18
Screeds	15-21
Production Table	15-22
Slope Conversion Table/ Inches in Decimals Table	15-23

### VIBRATORY AND PNEUMATIC

#### TIRE COMPACTORS

Sustainability	15-24
Features	15-24
Specifications: Vibratory Compactors	15-25
Pneumatic Tire Compactors	15-36
Pneumatic Tires: Inflation Pressures	15-37
Ballast Configurations	15-37
Maximum Ground Pressures	15-38
Production Estimating: Vibratory Compactors	15-39
Pneumatic Tire Compactors	15-43

### Cold Planer

#### Sustainability:

- **Long-lasting lubricants and fluids** extend maintenance intervals, decreasing the amount of waste and filters contributed to environment.
- **Superior Cat cutting tools last longer**, providing higher daily productivity with less fuel burn.
- **Ecology drains** provide a simple means to drain machine fluids with a minimized risk of spillage.
- **Maintenance free Cat batteries** are recyclable.
- **Engines with ACERT Technology** contribute less emissions to the environment.
- **Cold planers recycle aggregate from worn out roads** for use in new roads, reducing the cost and energy needs required for excavating, processing and hauling virgin aggregate.

#### Features:

- **Cat Engines with ACERT Technology.**
- **Up-cutting mandrels** provide cutting efficiency and improved bit life.
- **Short turning radii** for productivity and jobsite flexibility.
- **Front-discharge conveyor** facilitates haul unit movement in congested urban applications.
- **Optimum weight-to-horsepower balance** for delivering maximum available horsepower to the cutter.
- **Computerized Monitoring System (CMS)** provides three warning levels for abnormal operating conditions.
- **Load control system** keeps machine operating at peak efficiency.
- **Water spray system** for dust control and bit cooling.



MODEL	PM102		PM200 — 2.0 m		PM200 — 2.2 m		PM201	
Gross Power	168 kW	<b>225 hp</b>	429 kW	<b>575 hp</b>	429 kW	<b>575 hp</b>	485 kW	<b>650 hp</b>
Operating Weight	17 600 kg	<b>38,810 lb</b>	30 100 kg	<b>66,359 lb</b>	31 500 kg	<b>69,445 lb</b>	35 110 kg	<b>77,420 lb</b>
with Conical Rotor	—	—	—	—	—	—	39 165 kg	<b>86,360 lb</b>
with Breakaway Rotor	—	—	—	—	—	—	38 145 kg	<b>84,105 lb</b>
with Weld-on Rotor	—	—	—	—	—	—	38 050 kg	<b>83,905 lb</b>
Engine Model	<b>C7 with ACERT™ Technology</b>		<b>C18 with ACERT™ Technology</b>		<b>C18 with ACERT™ Technology</b>		<b>C18 with ACERT™ Technology</b>	
Rated Engine RPM	<b>2200</b>		<b>1900</b>		<b>1900</b>		<b>2100</b>	
No. of Cylinders	<b>6</b>		<b>6</b>		<b>6</b>		<b>6</b>	
Bore	110 mm	<b>4.3"</b>	145 mm	<b>5.7"</b>	145 mm	<b>5.7"</b>	145 mm	<b>5.7"</b>
Stroke	127 mm	<b>5.0"</b>	183 mm	<b>7.2"</b>	183 mm	<b>7.2"</b>	183 mm	<b>7.2"</b>
Displacement	7.2 L	<b>442 in³</b>	18.1 L	<b>1105 in³</b>	18.1 L	<b>1105 in³</b>	18.1 L	<b>1105 in³</b>
Drive Systems: Rotor	<b>Mechanical</b>		<b>Mechanical</b>		<b>Mechanical</b>		<b>Mechanical</b>	
Ground	<b>Hydrostatic with 4 track design</b>		<b>Hydrostatic with 4 track design</b>		<b>Hydrostatic with 4 track design</b>		<b>Hydrostatic with 4 track design</b>	
Discharge Conveyor Width	600 mm	<b>23.6"</b>	800 mm	<b>31.5"</b>	800 mm	<b>31.5"</b>	915 mm	<b>36"</b>
Width of Standard Track Shoe	225 mm	<b>8.8"</b>	300 mm	<b>12"</b>	300 mm	<b>12"</b>	348 mm	<b>14"</b>
Track Length on Ground	720 mm	<b>28.3"</b>	1640 mm	<b>64.5"</b>	1640 mm	<b>64.5"</b>	2045 mm	<b>80.5"</b>
Operating Dimensions:								
Height	3400 mm	<b>11'2"</b>	3950 mm	<b>12'7"</b>	3950 mm	<b>12'7"</b>	5040 mm	<b>16'6"</b>
Width	2500 mm	<b>8'2"</b>	2750 mm	<b>9'0"</b>	2970 mm	<b>9'9"</b>	2810 mm	<b>9'2"</b>
Length	10 700 mm	<b>35'1"</b>	13 940 mm	<b>45'7"</b>	13 940 mm	<b>45'7"</b>	15 100 mm	<b>49'5"</b>
Standard Mandrel (Width of Cut)	1000 mm	<b>40"</b>	2010 mm	<b>79"</b>	2235 mm	<b>88"</b>	2100 mm	<b>83"</b>
No. of Teeth	<b>97</b>		<b>178</b>		<b>193</b>		—	
Depth of Cut (Max.)	305 mm	<b>12"</b>	320 mm	<b>12.6"</b>	320 mm	<b>12.6"</b>	305 mm	<b>12"</b>
Speeds: Operating (Max.)								
Track undercarriage	27 m/min	<b>89 ft/min</b>	38 m/min	<b>125 ft/min</b>	38 m/min	<b>125 ft/min</b>	40 m/min	<b>132 ft/min</b>
Wheel undercarriage	46 m/min	<b>151 ft/min</b>	—	—	—	—	—	—
Speeds: Travel (Max.)								
Track undercarriage	4.1 km/h	<b>2.5 mph</b>	5.9 km/h	<b>3.6 mph</b>	5.9 km/h	<b>3.6 mph</b>	6.0 km/h	<b>3.7 mph</b>
Wheel undercarriage	6.4 km/h	<b>3.9 mph</b>	—	—	—	—	—	—
Inside Turning Radius: Right								
Track undercarriage	3450 mm	<b>11'3"</b>	2000 mm	<b>6'5"</b>	2000 mm	<b>6'5"</b>	4660 mm	<b>15'4"</b>
Wheel undercarriage	2100 mm	<b>6'8"</b>	—	—	—	—	—	—
Fuel Capacity	400 L	<b>105 U.S. gal</b>	1100 L	<b>290 U.S. gal</b>	1100 L	<b>290 U.S. gal</b>	946 L	<b>250 U.S. gal</b>
Water Capacity	1060 L	<b>280 U.S. gal</b>	3500 L	<b>925 U.S. gal</b>	3500 L	<b>925 U.S. gal</b>	3787 L	<b>1000 U.S. gal</b>

		<b>Cutter/Drum Width — m<sup>2</sup>/min (yd<sup>2</sup>/min)</b>									
<b>Speed</b>		<b>1000 mm (3'4")</b>		<b>1220 mm (4'0")</b>		<b>1900 mm (6'3")</b>		<b>2010 mm (6'7")</b>		<b>2100 mm (6'11")</b>	
<b>m/min</b>	<b>ft/min</b>	<b>m<sup>2</sup></b>	<b>yd<sup>2</sup></b>	<b>m<sup>2</sup></b>	<b>yd<sup>2</sup></b>	<b>m<sup>2</sup></b>	<b>yd<sup>2</sup></b>	<b>m<sup>2</sup></b>	<b>yd<sup>2</sup></b>	<b>m<sup>2</sup></b>	<b>yd<sup>2</sup></b>
3.0	10	3.0	3.7	3.7	4.4	5.8	6.9	6.1	7.3	6.4	7.7
4.6	15	4.6	5.5	5.6	6.6	8.7	10.4	9.3	11.0	9.7	11.5
6.1	20	6.1	7.3	7.5	8.8	11.6	13.9	12.3	14.6	12.8	15.4
7.6	25	7.6	9.2	9.3	11.1	14.5	17.4	15.4	18.3	16.1	19.2
9.1	30	9.1	11.0	11.1	13.3	17.4	20.8	18.4	22.0	19.2	23.1
10.7	35	10.7	12.8	13.1	15.5	20.3	24.3	21.6	25.6	22.6	26.9
12.2	40	12.2	14.7	15.0	17.8	23.2	27.8	24.6	29.3	25.7	30.7
13.7	45	13.7	16.5	16.8	20.0	26.1	31.2	27.7	33.0	28.9	34.6
15.2	50	15.2	18.3	18.7	22.2	29.0	34.7	30.7	36.6	32.1	38.4
16.8	55	16.8	20.2	20.6	24.4	31.9	38.2	33.9	40.2	35.4	42.3
18.3	60	18.3	22.0	22.5	26.7	34.9	41.7	37.0	43.9	38.7	46.1
<b>Speed</b>		<b>2210 mm (7'3")</b>		<b>3050 mm (10'0")</b>		<b>3500 mm (11'6")</b>		<b>3810 mm (12'6")</b>			
<b>m/min</b>	<b>ft/min</b>	<b>m<sup>2</sup></b>	<b>yd<sup>2</sup></b>	<b>m<sup>2</sup></b>	<b>yd<sup>2</sup></b>	<b>m<sup>2</sup></b>	<b>yd<sup>2</sup></b>	<b>m<sup>2</sup></b>	<b>yd<sup>2</sup></b>		
3.0	10	6.7	8.0	9.3	11.1	10.7	12.8	11.6	13.9		
4.6	15	10.0	12.1	13.9	16.7	16.1	19.2	17.4	20.8		
6.1	20	13.4	16.1	18.6	22.2	21.4	25.5	23.3	27.8		
7.6	25	16.7	20.1	23.2	27.8	26.8	31.9	29.1	34.7		
9.1	30	20.1	24.2	27.9	33.3	32.1	38.3	34.9	41.7		
10.7	35	23.4	28.2	32.5	38.9	37.5	44.7	40.7	48.6		
12.2	40	26.8	32.2	37.1	44.4	42.8	51.1	46.5	55.5		
13.7	45	30.1	36.2	41.8	50.0	48.2	57.5	52.3	62.5		
15.2	50	33.5	40.3	46.4	55.5	53.5	63.9	58.1	69.4		
16.8	55	36.8	44.3	51.1	61.1	58.9	70.3	63.9	76.4		
18.3	60	40.1	48.3	55.7	66.7	64.2	76.7	69.8	83.3		

**NOTE:** Above figures are based on a one-inch depth of cut. For greater depths of cut, multiply the production rate by cutting depth. Based on asphalt density of 68 kg/m<sup>3</sup> (115 lb/yd<sup>3</sup>), one inch thick.

		<b>Cutter/Drum Width — metric tons/min (U.S. tons/min)</b>									
<b>Speed</b>		<b>1000 mm (3'4")</b>		<b>1220 mm (4'0")</b>		<b>1900 mm (6'3")</b>		<b>2010 mm (6'7")</b>		<b>2100 mm (6'11")</b>	
<b>m/min</b>	<b>ft/min</b>	<b>Metric tons</b>	<b>U.S. tons</b>	<b>Metric tons</b>	<b>U.S. tons</b>	<b>Metric tons</b>	<b>U.S. tons</b>	<b>Metric tons</b>	<b>U.S. tons</b>	<b>Metric tons</b>	<b>U.S. tons</b>
3.0	10	0.005	0.006	0.23	0.26	0.36	0.40	0.38	0.42	0.41	0.44
4.6	15	0.008	0.009	0.35	0.38	0.54	0.60	0.57	0.63	0.61	0.66
6.1	20	0.011	0.012	0.46	0.51	0.72	0.80	0.76	0.84	0.82	0.88
7.6	25	0.013	0.013	0.58	0.64	0.91	1.00	0.94	1.04	1.02	1.10
9.1	30	0.016	0.018	0.69	0.77	1.09	1.20	1.14	1.26	1.23	1.33
10.7	35	0.018	0.020	0.81	0.89	1.27	1.40	1.34	1.47	1.44	1.55
12.2	40	0.021	0.023	0.92	1.02	1.45	1.60	1.53	1.68	1.65	1.76
13.7	45	0.024	0.026	1.04	1.15	1.63	1.80	1.71	1.88	1.84	1.99
15.2	50	0.026	0.029	1.16	1.28	1.81	2.00	1.91	2.10	2.05	2.21
16.8	55	0.029	0.032	1.27	1.41	1.99	2.20	2.09	2.31	2.25	2.43
18.3	60	0.032	0.035	1.39	1.53	2.18	2.40	2.28	2.51	2.46	2.65
<b>Speed</b>		<b>2210 mm (7'3")</b>		<b>3050 mm (10'0")</b>		<b>3500 mm (11'6")</b>		<b>3810 mm (12'6")</b>			
<b>m/min</b>	<b>ft/min</b>	<b>Metric tons</b>	<b>U.S. tons</b>	<b>Metric tons</b>	<b>U.S. tons</b>	<b>Metric tons</b>	<b>U.S. tons</b>	<b>Metric tons</b>	<b>U.S. tons</b>		
3.0	10	0.44	0.46	0.58	0.64	0.67	0.74	0.73	0.80		
4.6	15	0.66	0.69	0.87	0.96	1.00	1.10	1.09	1.20		
6.1	20	0.88	0.92	1.16	1.28	1.34	1.47	1.46	1.79		
7.6	25	1.10	1.15	1.45	1.60	1.67	1.83	1.82	1.99		
9.1	30	1.32	1.39	1.74	1.91	2.01	2.20	2.19	2.40		
10.7	35	1.54	1.62	2.03	2.24	2.34	2.57	2.56	2.79		
12.2	40	1.76	1.85	2.32	2.55	2.68	2.94	2.92	3.19		
13.7	45	1.98	2.08	2.61	2.87	3.01	3.31	2.28	3.59		
15.2	50	2.20	2.32	2.90	3.19	3.35	3.67	3.65	3.99		
16.8	55	2.42	2.55	3.19	3.51	3.68	4.04	4.01	4.39		
18.3	60	2.64	2.78	3.48	3.83	4.02	4.41	4.38	4.79		

**NOTE:** Above figures are based on a one-inch depth of cut. For greater depths of cut, multiply the production rate by cutting depth. Based on asphalt density of 68 kg/m<sup>3</sup> (115 lb/yd<sup>3</sup>), one inch thick.

## MACHINE SELECTION

Prime considerations in selecting the proper cold planer model are:

- specifics of work to be done
- type of projects generally done by the contractor
  - City/Urban or Highway/Airport
- desired production capacities

### PM102 Cold Planer

The Cat® PM102 Cold Planer features compact dimensions and excellent maneuverability ideal for easy operation in urban applications. The machine performs controlled, full-depth removal of asphalt layers in a single pass and is also capable of concrete removal. The machine is available with a wheel or track undercarriage and features four steering modes for high maneuverability.

### PM200 Cold Planer

The Cat® PM200 Cold Planer is a high-production, half-lane milling machine with excellent maneuverability and plenty of power to perform controlled full-depth removal of asphalt and concrete pavements in a single pass. The track-driven machine features four steering modes for high maneuverability. The PM200 is available in two configurations. The first configuration features a 2.0 m (79") cutting width and performs well in urban environments or in applications where great maneuverability is required. The second configuration features a 2.2 m (88") cutting width and is ideal for high-production applications such as main line milling.

### PM201 Cold Planer

The Cat® PM201 Cold Planer is a high-production, half-lane milling machine with excellent maneuverability and plenty of power to perform controlled full-depth removal of asphalt and concrete pavements in a single pass. The track-driven machine features four steering modes for high maneuverability.

### Cold Planer Characteristics (Highway/Airport)

Highway/Airport work requires high-volume cold planers. The PM200, PM201 and other high horsepower half-lane cold planers are being used more on Highway/Airport projects. Users like to have one machine that can work successfully on high production jobs then switch to city/urban applications. The PM201 has proven to be a true cross-over cold planer.

### Cold Planer Characteristics (City/Urban)

All Cat cold planers are four-track, front discharge models. Front discharge cold planers make traffic

control easier in congested quarters. The trucks travel forward in the same direction as the cold planer. The trucks move in and out of traffic faster increasing production.

## COLD PLANING FUNDAMENTALS

### Definition

Cold planing is automatically controlled cold milling to restore the pavement surface to a specified grade and slope; remove bumps, ruts, and other imperfections; and leave a textured surface which can be opened immediately to traffic or overlaid with new pavement materials.

### Production and Tooth Wear

Because pavement materials vary, so do production and tooth wear. While predicting the exact production rate and tooth wear on a particular job is difficult, general guidelines are available.

Production depends on the milling rate (the speed at which the cold planer moves forward). The machine's forward speed is determined, primarily, by aggregate type, asphalt bond strength and depth of cut. When milling asphalt pavement, the cold planer's teeth essentially are breaking the bond between asphalt-coated aggregate, not actually fracturing the aggregate itself. A pavement made with a mix containing a high percentage of fine aggregate and a high asphalt content is more difficult to mill than a pavement with a high percentage of coarse aggregate.

A dense or fine mix usually requires more power at the cutting drum, limiting the cold planer's forward speed. Decreased speed lowers production, and the tough bond between the small aggregate particles causes increased cutting-tooth wear. Lower production and higher tooth wear result in increased unit costs.

Cutting depth affects power demand at the drum and helps determine the cold planer's forward speed. However, production increases, to a point, as the depth of cut increases. For example, changing from a 25 mm (1 in) cut to a 51 mm (2 in) cut slows the machine only slightly but doubles the amount of material produced.

As the cut increases beyond the machine's peak-production depth, the reduced forward speed begins to offset the production gains of the deeper cut. For example, production at a 152 mm (6 in) cutting depth and slow speed may be no greater than cutting at a 76 mm (3 in) depth and a much faster speed.



**Low Density Asphalt**

Depth		PM201	
mm	in	m/min	ft/min
51	2	40	130
101	4	32	105
127	5	21	70
178	7	12	40
254	10	6	20
305	12	5	15

**High Density Asphalt**

Depth		PM201	
mm	in	m/min	ft/min
51	2	32	105
101	4	26	85
127	5	18	60
178	7	9	30
254	10	5	15
305	12	4	12

As long as the cold planer maintains a productive forward speed, deeper cuts will yield greater production and tend to lower tooth cost. Tooth wear does not increase in direct proportion to production when the machine is working in an efficient range.

Tooth wear at various depths for a given material is affected by how long the tooth remains in the cut. Because the teeth are mounted on a circular drum, each tooth cuts through the pavement in an arc. The tooth arc at a 102 mm (4 in) cutting depth, however, is not four times longer than at a 25 mm (1 in) cutting depth, even though production may be four times greater. The cutting arc at 102 mm (4 in) is approximately twice as long as that at 25 mm (1 in).

The peak cutting depth for a particular cold planer on a specific job is best determined by examining production, and subsequent costs, of a single deep cut versus multiple passes at a shallow depth.

**TYPES OF CUTTING ROTORS****Weld on Holders**

The holders that retain the cutting bits are welded to the rotor flight. Best used in applications that have little or no obstacles imbedded in the pavement.

**Bolt on Holders**

The holders are bolted to a spacer block that is welded to the rotor flight. No welding is required to replace holders that are broken by obstacles embedded in the pavement.

## APPLICATIONS

Although new applications for cold planers are being discovered, most work can be classified in six general categories:

### Leveling and Bonding

This application removes a layer of pavement to eliminate potholes, ruts, bumps and other surface imperfections. The cold planer leaves a level, textured surface ideal for bonding to a new, thin overlay of asphalt or concrete. The surface has an interlocking texture with double the bonding area of a conventional smooth pavement. The textured surface and overlay form a monolithic bond, eliminating the shear plane that causes pavement layers to move and separate. Thinner overlays can be used, making the technique more economical than traditional overlay methods.

### Surface Refinishing

Rough pavement can also be cold planed to specified grade and slope, providing a new riding surface without adding new paving materials. This application is particularly useful when base and sub-base are in good shape, or when several layers have been added to the roadway over the years. Roads can be cold planed during cold, wet months and reopened immediately. New overlays can be added whenever weather permits. This lengthens the practical working season for many contractors. The cold planer can also be used to correct expansion joint faults and pavement cracks.

### Surface Repair

This category generally requires deeper cutting than leveling. It consists of removing isolated distressed pavement sections down to subbase, if necessary, prior to adding new overlay materials. Since the cutter mandrel on Cat cold planers cuts forward and upward, there's no damaging impact to the underlying base.

### Pavement Removal

Pavement buildup is a problem that plagues most older streets, roads and highways. As overlays are added, curbs and drains are buried — creating drainage problems. Overhead clearances are dangerously reduced ... and additional weight is added to overpasses and bridges. Cold planing is an economical method of curing all these problems.

### Surface Texturing

Serious accidents increase when pavement becomes slick from wear. The textured surface produced by cold planing is highly skid-resistant and has dramatically reduced hydroplaning characteristics.

### Pavement Mining

Cold milling has made it practical to actually "mine" deteriorated pavement materials from existing roads and streets. The cold planer produces an ideally-sized asphalt or concrete material which can be recycled in a variety of ways. Depending on type, age and condition of pavement, the largest cold planer can reclaim up to 900 tons of material per hour.

**COLD PLANER USE BY PROJECT TYPE**

<b>Applications</b>	<b>Highway/Airport</b>	<b>City/Urban</b>
Planing (Milling)	<ul style="list-style-type: none"> <li>● To establish grade and slope.</li> <li>● Remove excess pavement.</li> </ul>	<ul style="list-style-type: none"> <li>● To establish proper grade and slope.</li> <li>● To establish new grade and slope.</li> </ul>
Partial Removal	<ul style="list-style-type: none"> <li>● For use with hot mix recycle.</li> <li>● Remove pavement irregularities.</li> <li>● Texture for skid resistance.</li> </ul>	<ul style="list-style-type: none"> <li>● To correct drainage and curb reveal.</li> <li>● To lower elevation at overpass.</li> <li>● For use with hot recycle.</li> <li>● Eliminate leveling course.</li> </ul>
Full Depth Removal	<ul style="list-style-type: none"> <li>● Total rebuild. RAP used for base or hot recycle.</li> <li>● Cold recycle. This requires additional surface treatment.</li> </ul>	<ul style="list-style-type: none"> <li>● Total rebuild. RAP used for base or hot recycle.</li> <li>● Cold recycle. Requires additional surface treatment.</li> </ul>
Texturing	<ul style="list-style-type: none"> <li>● For skid resistance and improved bond when overlay is applied.</li> </ul>	<ul style="list-style-type: none"> <li>● For skid resistance and improved bond when overlay is applied.</li> </ul>
Leveling		<ul style="list-style-type: none"> <li>● At intersections to remove bumps, shoving and improve drainage.</li> </ul>
Special	<ul style="list-style-type: none"> <li>● Joint and crack repair.</li> <li>● Cut rumble grooves on shoulders of bridge approaches.</li> </ul>	<ul style="list-style-type: none"> <li>● Intersection defect repair.</li> <li>● Pothole repair.</li> <li>● Railroad crossing repair.</li> <li>● Tight radius profiling around manhole covers, etc.</li> <li>● Pavement adjustments (transitions from existing pavements to new overlays).</li> </ul>

**RM300 and RM500:**

The RM300 and the RM500 combine superior performance and reliability to achieve the most demanding job specifications while maximizing machine uptime. With many enhanced features and options, the RM300 and the RM500 are designed to work well in both full depth reclamation and soil stabilization applications.

**Rotary Mixers****Sustainability:**

- Long-lasting lubricants and fluids extend maintenance intervals, decreasing the amount of waste and filters contributed to environment.
- Ecology drains provide a simple means to drain machine fluids with a minimized risk of spillage.
- Maintenance free Cat batteries are recyclable.
- Engines with ACERT Technology contribute less emissions to the environment.
- Rotary Mixers recycle the materials into aggregate on site. That means no fuel consumption or emissions from haul trucks.
- Rotary Mixers and the reclamation process can eliminate the need for an excavator and motor grader at most job sites.
- Rotary Mixers can reclaim and stabilize simultaneously. If stabilization is required, the agent can be placed on top of the reclamation project. The Rotary Mixer then makes a single pass, mixing the stabilizer with the material beneath the surface. At the same time, it reduces the aggregate to its original size. All this is accomplished with one machine — in one pass.
- The reclamation and stabilization process can easily incorporate environmentally sensitive sealants. Now the life of the road bases can be extended without fear of harming wildlife.

- The reclamation process usually is quicker than full replacement, allowing roads to open sooner. This means fewer traffic jams — a quality of life issue as well.
- Reclamation and stabilization dramatically extend the life of roads. Some contractors conservatively estimate that a reclaimed/stabilized base will help a recycled road last 30 to 40 years. Extending that life is an enormous cost-saver, and also results in the use of less energy.

**RM300 Features:**

- **Maximum Production** ... from Cat engines with ACERT Technology.
- **Highly Efficient** ... load-sensing propel system helps prevent overloading while allowing continuous work near rated horsepower.
- **Extremely Versatile** ... interchangeable rotors provide both reclamation and stabilization capabilities.
- **Consistent Blending** ... automatic depth control, mid-mounted mixing chamber and multi-speed rotor drive combine for optimum blending and increased production.

**RM500 Features:**

- **Maximum Production** ... from Cat engines with ACERT Technology.
- **Highly Maneuverable** ... separate hydraulic pump provides hydraulic flow to large displacement motors on each rear wheel.
- **Versatility** ... choice of three rotors for full depth reclamation or soil stabilization.
- **Reliability** ... field proven Cat components maximize machine availability.



MODEL	RM300		RM500	
Gross Power	261 kW	350 hp	403 kW	540 hp
Operating Weight with ROPS, cab and universal rotor	24 454 kg	53,911 lb	28 145 kg	62,060 lb
Engine Model	<b>C11 with ACERT Technology</b>		<b>C15 with ACERT Technology</b>	
Rated Engine RPM	1800		2000	
No. Cylinders	6		6	
Bore	130 mm	5.1"	137 mm	5.4"
Stroke	140 mm	5.5"	171 mm	6.7"
Displacement	11.1 L	680 in <sup>3</sup>	15.1 L	923 in <sup>3</sup>
Drive Systems: Rotor Propel	<b>3 Speed Chain Hydrostatic/Planetary</b>		<b>3 Speed Chain Hydrostatic/Planetary</b>	
Operating Dimensions: Height	3500 mm	11'6"	3480 mm	11'4"
Width	3000 mm	9'10"	2980 mm	9'7"
Length	10 000 mm	32'10"	9680 mm	31'8"
Width of Cut	2438 mm	8'0"	2438 mm	8'0"
Depth of Cut (Max.)	457 mm	18"	508 mm	20"
Rotor Speed	<b>@ 1800 engine rpm</b>		<b>@ 2000 engine rpm</b>	
	First	106 rpm	First	110 rpm
	Second	144 rpm	Second	152 rpm
	Third	216 rpm	Third	205 rpm
Minimum Turning Radius: Standard	3900 mm	12'10"	3700 mm	12'1"
Travel Speed (Max.): Working	4.3 km/h	2.7 mph	3.2 km/h	2.0 mph
Roading	9.7 km/h	6.0 mph	9.2 km/h	5.7 mph
Standard Tires: Front	<b>28.1 × 26 18-ply Lug Type R-1</b>		<b>26.5 × 25 20-ply Lug Type R-1</b>	
Rear	<b>18.4 × 30 12-ply Lug Type R-1</b>		<b>23.1 × 26 26-ply Lug Type R-1</b>	
Fuel Capacity	1056 L	279 U.S. gal	1506 L	279 U.S. gal
Cooling System	62.5 L	16.5 U.S. gal	81 L	21.4 U.S. gal
Crankcase	32 L	8.5 U.S. gal	34 L	8.9 U.S. gal

**Rotor Options for RM300 and RM500**

Rotor	Maximum Depth of Work		No. of Bits/Tools	Direction of Cut	Stabilization	Reclamation
Universal 406 mm (16")*	406 mm	16"	200	Up	X	X
Universal 457 mm (18")**	457 mm	18"	200	Up	X	X
Soil	508 mm	20"	238	Up	X	
Combination	508 mm	20"	114	Up	X	
Spade	457 mm	18"	58	Up	X	

\*Designed to produce maximum breakout force, the Universal Rotor 406 mm (16") performs well in severe asphalt cuts.

\*\*The Universal Rotor 457 mm (18") is designed to provide maximum mixing depth and has lower breakout force compared to the Universal Rotor 406 mm (16").

**Rotor Options:**

*Some rotor options are not available in certain markets.*

- **Soil Rotor** is designed primarily for use in soil stabilization.
- **Combination Rotor** is designed primarily for use in soil stabilization with a secondary application in light cuts of asphalt reclamation.
- **Universal Rotor** can be used for either reclamation or stabilization.
- **Spade Rotor** is designed for soil stabilization applications.

**PRODUCTION ESTIMATING**

The maximum cutting depth is 381 mm (15 in) for the RM300 and 457 mm (18 in) for the RM500. The RM300 can mix up to 457 mm (18 in). In addition, the cutting width of their rotors is 2.4 m (8 ft). The following formulas allow you to determine the production in square yards (yd<sup>2</sup>)/minute or cubic yards (yd<sup>3</sup>)/minute.

Production in square yards (yd<sup>2</sup>) per minute

$$\frac{9 \text{ ft}^2/\text{yd}^2}{8 \text{ ft Cutting width}} = \frac{\text{FPM of travel speed}}{1.125}$$

= 1.125 (This is a constant value for an eight foot wide rotor)

Gallons of additive (for units with pump and metering additive system)

$$\frac{\text{GPM}}{\text{yd}^2/\text{min}} = \text{gal}/\text{yd}^2$$

Or, if required additive amounts are known, you can determine necessary travel speed as shown:

$$\frac{\text{GPM}}{\text{gal}/\text{yd}^2} = \text{yd}^2/\text{min}; \text{yd}^2/\text{min} \times 1.125 = \text{ft}/\text{min}$$

Production in Cubic Yards (yd<sup>3</sup>) per minute

$$\frac{\text{FPM of travel speed}}{1.125} \times \frac{\text{Cutting or mixing depth in inches}}{36} = \frac{\text{yd}^3}{\text{min}}$$

Production in Tons per Minute

$$\text{yd}^3/\text{min} \times \frac{\text{Wt. of Material per yd in lbs}}{2000 \text{ lb}/\text{ton}} = \text{tons}/\text{min}$$

**Abbreviations**

FPM = Feet Per Minute

GPM = Gallons Per Minute

**WEIGHT OF MATERIALS**

Material	LOOSE		IN-PLACE		
	kg/m <sup>3</sup>	lb/yd <sup>3</sup>	kg/m <sup>3</sup>	lb/yd <sup>3</sup>	
Clay	— Dry	1480	2500	1840	3100
	— Wet	1660	2800	2080	3500
Clay and Gravel	— Dry	1420	2400	1660	2800
	— Wet	1540	2600	1840	3100
Sand and Gravel	— Dry	1720	2900	1930	3250
	— Wet	2020	3400	2220	3750
Sand	— Dry	1420	2400	1600	2700
	— Damp	1690	2850	1900	3200
	— Wet	1840	3100	2080	3500
Earth	— Dry Packed	1510	2550	1900	3200
	— Wet Excavated	1600	2700	2020	3400
	— Top Soil	950	1600	1360	2300
	— Loam	1250	2100	1540	2600
Bituminous Concrete	— Windrowed Chunks (25% Voids)	1740	2925	—	—
	— Compacted	—	—	2310	3900

**STABILIZATION/RECLAMATION PRODUCTION**

The following charts list production in square meters per minute, square yards per minute, cubic meters per minute, and cubic yards per minute. The information is based on various travel speeds and cutting depths for the Cat RM500, RM300 and SS-250B equipped with a 2438 mm (8 ft) cutting rotor.

PRODUCTION RATES																		
Travel Speed m/min	m <sup>2</sup> / min	m <sup>3</sup> /minute																
		Cutting Depth — mm																
		100	125	150	175	200	225	250	275	300	325	350	375	400	425	450	475	500
3	7.3	0.73	0.9	1.1	1.3	1.5	1.6	1.8	2.0	2.2	2.4	2.6	2.7	2.9	3.1	3.3	3.5	3.7
6	14.6	1.46	1.8	2.2	2.6	2.9	3.3	3.7	4.0	4.4	4.8	5.1	5.5	5.9	6.2	6.6	6.9	7.3
9	21.9	2.2	2.7	3.3	3.8	4.4	4.9	5.5	6.0	6.6	7.1	7.7	8.2	8.8	9.3	9.9	10.4	11.0
12	29.3	2.9	3.7	4.4	5.1	5.9	6.6	7.3	8.0	8.8	9.5	10.2	11.0	11.7	12.4	13.2	13.9	14.6
15	36.6	3.6	4.6	5.5	6.4	7.3	8.2	9.1	10.0	11.0	11.9	12.8	13.7	14.6	15.5	16.5	17.4	18.3
18	43.9	4.4	5.5	6.6	7.7	8.8	9.9	11.0	12.1	13.2	14.3	15.4	16.5	17.6	18.7	19.7	20.8	21.9
21	51.2	5.1	6.4	7.7	9.0	10.2	11.5	12.8	14.1	15.4	16.6	17.9	19.2	20.5	21.8	23.0	24.3	25.6
24	58.5	5.9	7.3	8.8	10.2	11.7	13.2	14.6	16.1	17.6	19.0	20.5	21.9	23.4	24.9	26.3	27.8	29.3
27	65.8	6.6	8.2	9.9	11.5	13.2	14.8	16.4	18.1	19.7	21.4	23.0	24.7	26.3	28.0	29.6	31.3	32.9

PRODUCTION RATES																		
Travel Speed ft/min	yd <sup>2</sup> / min	yd <sup>3</sup> /minute																
		Cutting Depth — inches																
		4	5	6	7	8	9	10	11	12	13	14	15	16	17	18	19	20
10	8.9	0.98	1.2	1.5	1.7	2.0	2.2	2.5	2.7	3.0	3.2	3.5	3.7	4.0	4.2	4.5	4.7	4.9
20	17.8	1.96	2.5	3.0	3.4	4.0	4.4	4.9	5.5	5.9	6.4	6.9	7.4	7.9	8.4	8.9	9.4	9.9
30	26.7	2.9	3.7	4.5	5.2	5.9	6.7	7.4	8.2	8.9	9.6	10.4	11.1	11.9	12.6	13.4	14.0	14.8
40	35.6	3.9	4.9	5.9	6.9	7.9	8.9	9.9	10.9	11.9	12.8	13.9	14.8	15.8	16.8	17.8	18.7	19.8
50	44.5	4.9	6.2	7.4	8.6	9.9	11.1	12.4	13.6	14.8	16.0	17.3	18.5	19.8	21.0	22.3	23.4	24.7
60	53.4	5.9	7.4	8.9	10.3	11.9	13.3	14.8	16.4	17.8	19.2	20.8	22.2	23.7	25.2	26.7	28.1	29.7
70	62.3	6.8	8.6	10.4	12.0	13.8	15.6	17.3	19.1	20.8	22.4	24.3	25.9	27.7	29.5	31.2	32.8	34.6
80	71.2	7.8	9.9	11.9	13.7	15.8	17.8	19.8	21.8	23.7	25.6	27.7	29.6	31.6	33.7	35.6	37.5	39.6
90	80.1	8.8	11.1	13.4	15.5	17.8	20.0	22.4	24.5	26.7	28.8	31.2	33.3	35.6	37.9	40.1	42.1	44.5

**Asphalt Pavers****Sustainability:**

- Long-lasting lubricants and fluids extend maintenance intervals, decreasing the amount of waste and filters contributed to environment.
- Ecology drains provide a simple means to drain machine fluids with a minimized risk of spillage.
- Maintenance free Cat batteries are recyclable.
- Engines with ACERT Technology contribute less emissions to the environment.
- Automatic speed control reduces fuel consumption and lowers emissions.
- Proprietary undercarriage design on Mobil-trac pavers significantly reduces track belt wear, reducing frequency of replacement.
- Cat electric-heated screeds provide a reduction in emissions, which is not only good for the environment but helps prevent soot build-up on indicators and decals — giving safety a boost as well.
- Electric-heated screeds produce less noise, which is appreciated by the crew as well as those who work and live near the construction sites.
- Electric-heated screeds, unlike their diesel counterparts, don't require a constant flame — another way emissions are reduced, and operators spared some heat.
- Electric-heated screeds are 136 kg (300 lb) lighter, which means the paver consumes less fuel.
- Electric-heated screeds warm up quickly, another energy saver.

**Features:**

- **Variable width screeds** available.
- **Hydrostatic pumps** provide infinitely variable speed ranges.
- **Direct hydrostatic drives** eliminate gear boxes, differentials, final drive chains etc.
- **Self-dumping hydraulic hoppers** are heavy-duty and high capacity.
- **Soldered and molded** electrical connections.
- **Feeder system** designed to eliminate power segregation and manual hand work.
- **Self diagnostics** on propel and feeder systems.





MODEL	AP300*		AP500E		AP500E*	
Gross Power	52 kW	70 hp	106 kW	142 hp	106 kW	144 hp
Rated Engine RPM	2200		2200		2200	
No. Cylinders	4		4		4	
Displacement	4.4 L	269 in <sup>3</sup>	4.4 L	439 in <sup>3</sup>	4.4 L	439 in <sup>3</sup>
Engine Model	3054C DINA		C4.4 with ACERT Technology		C4.4 with ACERT Technology	
Operating Weight:						
Tractor	6000 kg	13,228 lb	12 590 kg	27,760 lb	16 145 kg	35,600 lb
Speeds:						
Paving	0-85 m/min	0-279 ft/min	61 m/min	200 ft/min	61 m/min	200 ft/min
Travel	0-16 km/h	0-26 mph	16 km/h	10 mph	16 km/h	10 mph
Tires:						
Front (4)	455 × 260 Solid Rubber		13 × 22 Solid Rubber		13 × 22 Solid Rubber	
Rear (2)	365/80 R20		17.5 R25		17.5 R25	
Dimensions:						
Standard Paving Width	1700 mm	5'7"	2440 mm	8'0"	2440 mm	8'0"
Shipping Width (maximum)	1730 mm	5'8"	2.72 m	8'11"	2.72 m	8'11"
Height (less exhaust)	2960 mm	9'9"	2.82 m	9'3"	2.82 m	9'3"
Length (with push roller and screed)	4820 mm	15'10"	5.80 m	19'0"	5.80 m	19'0"
Turning Radius	3000 mm	9'10"	0.75 m	2'6"	0.75 m	2'6"
Wheelbase	1610 mm	5'3"	N/A		N/A	
Hopper Capacity	3.8 m <sup>3</sup>	134 ft <sup>3</sup>	6.2 m <sup>3</sup>	219 ft <sup>3</sup>	6.2 m <sup>3</sup>	219 ft <sup>3</sup>
Auger Diameter	260 mm	10"	406 mm	16"	406 mm	16"
Available Screens:						
AS3173		X		—		—
Extend-A-Mat 10-20B		—		—		—
AS2252C		—		X		—
AS2301		—		—		—
AS2302		—		—		—
AS3251C		—		X		—
AS4251		—		—		—
AS4251C		—		—		X
AS4252C		—		—		X
Service Refill Capacities:						
Cooling System	15 L	4 U.S. gal	30 L	7.9 U.S. gal	30 L	7.9 U.S. gal
Fuel Tank	79.5 L	21 U.S. gal	189 L	50 U.S. gal	189 L	50 U.S. gal
Hydraulic Oil Tank	150 L	40 U.S. gal	170 L	45 U.S. gal	170 L	45 U.S. gal

\*Model available in Europe, Africa, Middle East and Asia only.



MODEL	AP600D*		AP600D		AP1000D	
Gross Power	129.5 kW	176 hp	129 kW	174 hp	167 kW	224 hp
Rated Engine RPM	2200		2200		2200	
No. Cylinders	6		6		6	
Displacement	6.6 L	403 in <sup>3</sup>	6.6 L	403 in <sup>3</sup>	7.24 L	441.7 in <sup>3</sup>
Engine Model	C6.6 with ACERT Technology		C6.6 with ACERT Technology		C7 with ACERT Technology	
Operating Weight:						
Tractor	14 000 kg	30,865 lb	14 197 kg	31,299 lb	14 728 kg	32,470 lb
Speeds:						
Paving	0-25 m/min	0-82 ft/min	0-61 m/min	0-200 ft/min	0-91 m/min	0-300 ft/min
Travel	0-18 km/h	0-11 mph	0-18 km/h	0-11.2 mph	0-22 km/h	0-14 mph
Tires:						
Front (4)	13 × 22 Solid Rubber		13 × 22 Solid Rubber		16 × 22 Solid Rubber	
Rear (2)	16 × 25		16 × 25		18.00 × 25 Sand Rib	
Dimensions:						
Standard Paving Width	2500 mm	8'2"	2440 mm	8'0"	3000 mm	10'0"
Shipping Width (maximum)	2500 mm**	8'2"***	2720 mm	8'11"	3330 mm	10'11"
Height (less exhaust)	3019 mm	9'11"	2820 mm	9'3"	2820 mm	9'3"
Length (with push roller and screed)	6160 mm	20'2"	6580 mm	21'7"	6740 mm	22'1"
Turning Radius	1400 mm	4'8"	1400 mm	4'8"	2900 mm	9'6"
Wheelbase	2290 mm	7'6"	2290 mm	7'6"	2560 mm	8'4"
Hopper Capacity	6.5 m <sup>3</sup>	230 ft <sup>3</sup>	6.5 m <sup>3</sup>	230 ft <sup>3</sup>	6100 mm <sup>3</sup>	215 ft <sup>3</sup>
Auger Diameter	406 mm	16"	406 mm	16"	406 mm	16"
Available Screens:						
AS3173	—		—		—	
Extend-A-Mat 10-20B	—		—		X	
AS2252C	—		X		—	
AS2301	—		—		X	
AS2302	—		—		X	
AS3251C	—		X		—	
AS4251	—		—		—	
AS4251C	X		—		—	
AS4252C	X		—		—	
Service Refill Capacities:						
Cooling System	30 L	8 U.S. gal	30 L	8 U.S. gal	36 L	9.5 U.S. gal
Fuel Tank	291 L	77 U.S. gal	291 L	77 U.S. gal	446 L	118 U.S. gal
Hydraulic Oil Tank	218 L	58 U.S. gal	218 L	58 U.S. gal	151 L	39.9 U.S. gal

\*Model available in Europe, Africa, Middle East and Asia only.

\*\*Shipping width with hoppers raised and without end gates.



MODEL	AP555E		AP555E**		AP655D		AP655D**	
Gross Power	106 kW	142 hp	106 kW	1442 hp	129 kW	174 hp	129.5 kW	176 hp
Rated Engine RPM	2200		2200		2200		2200	
No. Cylinders	4		4		6		6	
Displacement	4.4 L	439 in <sup>3</sup>	4.4 L	439 in <sup>3</sup>	6.6 L	403 in <sup>3</sup>	6.6 L	403 in <sup>3</sup>
Engine Model	C4.4 with ACERT Technology		C4.4 with ACERT Technology		C6.6 with ACERT Technology		C6.6 with ACERT Technology	
Operating Weight:								
Tractor								
with Mobil-trac™	13 305 kg	29,335 lb	13 675 kg	30,148 lb	15 320 kg	33,775 lb	19 165 kg	42,259 lb
with Steel Track	N/A		N/A		15 320 kg	33,775 lb	19 165 kg	42,259 lb
Speeds:								
Paving (Mobil-trac™)	61 m/min	200 ft/min	25 m/min	82 ft/min	0-70 m/min	0-230 ft/min	0-25 m/min	0-82 ft/min
(Steel Track)	N/A		N/A		0-78 m/min	0-255 ft/min	0-25 m/min	0-82 ft/min
Travel (Mobil-trac™)	11 km/h	7 mph	11 km/h	7 mph	0-14.5 km/h	0-9 mph	0-14.8 km/h	0-9 mph
(Steel Track)	N/A		N/A		0-8 km/h	0-5 mph	0-5.3 km/h	0-3 mph
Tracks Assemblies:								
Width (Mobil-trac™)	406 mm	16"	406 mm	16"	406 mm	16"	406 mm	16"
(Steel Track)	N/A		N/A		356 mm	14"	356 mm	14"
Length on Ground (Mobil-trac™)	2460 mm	8'1"	2460 mm	8'1"	3020 mm	9'11"	3020 mm	9'11"
(Steel Track)	N/A		N/A		3048 mm	10'0"	2249 mm	7'5"
Total Number of Track Pads (Steel Track)	N/A		N/A		92		92	
Dimensions:								
Standard Paving Width	2440 mm	8'0"	2550 mm	8'4"	2440 mm	8'0"	2550 mm	8'4"
Shipping Width (maximum)*	2440 mm	8'0"	2500 mm	8'2"	2440 mm	8'0"	2500 mm	8'2"
Height (less exhaust)	2820 mm	9'3"	3100 mm	10'2"	2820 mm	9'3"	2920 mm	9'7"
Length (screed, push roller):	5.80 m	19'0"	5.75 m	18'10"	—	—	6160 mm	20'3"
with AS3251C Screed	6.11 m	20'0"	N/A		6800 mm	22'4"	—	
Turning Radius	304 mm	12"	304 mm	12"	304 mm	12"	304 mm	12"
Hopper Capacity	6.2 m <sup>3</sup>	219 ft <sup>3</sup>	6.2 m <sup>3</sup>	219 ft <sup>3</sup>	6.5 m <sup>3</sup>	230 ft <sup>3</sup>	6.5 m <sup>3</sup>	230 ft <sup>3</sup>
Auger Diameter	406 mm	16"	406 mm	16"	406 mm	16"	406 mm	16"
Available Screens:								
Extend-A-Mat 10-20B	—		—		—		—	
AS2252C	X		—		X		—	
AS2301	—		—		—		—	
AS2302	—		—		—		—	
AS3251C	X		—		X		—	
AS4251	—		—		—		—	
AS4251C	—		X		—		X	
AS4252C	—		X		—		X	
Service Refill Capacities:								
Cooling System	30 L	7.9 U.S. gal	30 L	7.9 U.S. gal	30 L	8 U.S. gal	30 L	8 U.S. gal
Fuel Tank	189 L	50 U.S. gal	189 L	50 U.S. gal	291 L	77 U.S. gal	290 L	77 U.S. gal
Hydraulic Oil Tank	170 L	45 U.S. gal	170 L	45 U.S. gal	218 L	58 U.S. gal	218 L	58 U.S. gal

\*Transport width with hoppers raised, without end gates and with screed.

\*\*Model available to Europe, Africa, Middle East, Australia, and Asia only.



MODEL	AP755**		AP1055D	
Gross Power	149 kW	202 hp	167 kW	224 hp
Rated Engine RPM	2200		2200	
No. Cylinders	6		6	
Displacement	7.2 L	439 in <sup>3</sup>	7.24 L	441.7 in <sup>3</sup>
Engine Model	C7 with ACERT Technology		C7 with ACERT Technology	
Operating Weight:				
Tractor	17 260 kg	38,058 lb	—	—
with Mobil-trac™	—	—	17 601 kg	37,580 lb
with Steel Track	—	—	16 601 kg	36,600 lb
Speeds:				
Paving (Mobil-trac™)	—	—	0-67 m/min	0-220 ft/min
(Steel Track)	0-26 m/min	0-85 ft/min	0-78 m/min	0-255 ft/min
Travel (Mobil-trac™)	—	—	0-15 km/h	0-9 mph
(Steel Track)	0-6 km/h	0-4 mph	0-8 km/h	0-5 mph
Tracks Assemblies:				
Width (Mobil-trac™)	—	—	457 mm	18"
(Steel Track)	300 mm	12"	356 mm	14"
Length on Ground (Mobil-trac™)	—	—	3023 mm	9'11"
(Steel Track)	3125 mm	10'3"	3048 mm	10'0"
Dimensions:				
Standard Paving Width	2500 mm	8'2"	3000 mm	10'0"
Shipping Width (maximum)*	2500 mm	8'2"	3380 mm	11'1"
Height (less exhaust)	3000 mm	9'10"	2820 mm	9'3"
Length (screed, push roller):	6500 mm	21'4"	—	—
with 10-20B Extend-A-Mat Screed	—	—	6540 mm	21'6"
with AS2301 Screed	—	—	6540 mm	21'6"
Turning Radius	1000 mm	3'3"	914 mm	3'0"
Hopper Capacity	7 m <sup>3</sup>	247 ft <sup>3</sup>	6.1 m <sup>3</sup>	215 ft <sup>3</sup>
Auger Diameter	360 mm	14"	406 mm	16"
Available Screens:				
Extend-A-Mat 10-20B	—	—	X	X
AS2301	—	—	X	X
AS2302	—	—	X	X
AS3251C	—	—	—	—
AS4251	X	X	—	—
AS4251C	—	—	—	—
Service Refill Capacities:				
Cooling System	54 L	14 U.S. gal	36 L	9.5 U.S. gal
Fuel Tank	295 L	78 U.S. gal	413 L	109 U.S. gal
Hydraulic Oil Tank	200 L	53 U.S. gal	149 L	39.4 U.S. gal

\*Transport width with hoppers raised, without end gates and with screed.

\*\*Model available to Europe, Africa, Middle East, Australia, and Asia only.

### Sustainability

- Long-lasting lubricants and fluids extend maintenance intervals, decreasing the amount of waste and filters contributed to environment.
- Ecology drains provide a simple means to drain machine fluids with a minimized risk of spillage.
- Maintenance free Cat batteries are recyclable.
- Engines with ACERT Technology contribute less emissions to the environment.
- Automatic speed control reduces fuel consumption and lowers emissions.
- Proprietary undercarriage design on Mobil-trac pavers significantly reduces track belt wear, reducing frequency of replacement.
- Cat electric-heated screeds provide a reduction in emissions, which is not only good for the environment but helps prevent soot build-up on indicators and decals — giving safety a boost as well.
- Electric-heated screeds produce less noise, which is appreciated by the crew as well as those who work and live near the construction sites.
- Electric-heated screeds, unlike their diesel counterparts, don't require a constant flame — another way emissions are reduced, and operators spared some heat.
- Electric-heated screeds are 136 kg (300 lb) lighter, which means the paver consumes less fuel.
- Electric-heated screeds warm up quickly, another energy saver.

### Features:

- **Variable width screeds** available for all Barber-Greene paver models.
- **Designed With the Crew In Mind ...** for simplified, more efficient operation and unmatched access to operational controls and service areas.
- **Simplified Drive System ...** variable pump/motor propel system that covers all machine speed ranges required to increase paver productivity.
- **Material Handling System ...** fully hydrostatic drive provides smooth efficient operation with the capability to handle today's varied paving requirements.
- **Service Accessibility ...** swing-out panels and decks provide generous access.
- **Complete Customer Support ...** unmatched in the paving industry.

Specifications  
 ● Barber-Greene  
 ● Rubber Tired Models

Asphalt Pavers



MODEL	BG500E		BG600D		BG-260D	
Gross Power	106 kW	142 hp	129 kW	174 hp	167 kW	224 hp
Rated Engine RPM	2200		2200		2200	
No. Cylinders	4		6		6	
Displacement	4.4 L	439 in <sup>3</sup>	6.6 L	403 in <sup>3</sup>	7.24 L	441.7 in <sup>3</sup>
Engine Model	C4.4 with ACERT Technology		C6.6 with ACERT Technology		C7 with ACERT Technology	
Operating Weight:						
Tractor	12 590 kg	27,760 lb	14 197 kg	31,299 lb	14 728 kg	32,470 lb
Speeds: Paving	61 m/min	200 ft/min	0-61 m/min	0-200 ft/min	0-91 m/min	0-300 ft/min
Travel	16 km/h	10 mph	0-18 km/h	0-11.2 mph	0-22 km/h	0-14 mph
Tires:						
Front (4)	13 × 22 Solid Rubber		13 × 22 Solid Rubber		16 × 22 Solid Rubber	
Rear (2)	17.5 R25		16 × 25		18.00 × 25 Sand Rib	
Dimensions:						
Standard Paving Width	2440 mm	8'0"	2440 mm	8'0"	3000 mm	10'0"
Shipping Width (maximum)*	2.72 m	8'11"	2720 mm	8'11"	3330 mm	10'11"
Height (less exhaust)	2.82 m	9'3"	2820 mm	9'3"	2820 mm	9'3"
Length (screed, push roller)	5.80 m	19'0"	6580 mm	21'7"	6740 mm	22'1"
Turning Radius	0.75 m	2'6"	1400 mm	4'8"	2900 mm	9'6"
Wheelbase	N/A		2290 mm	7'6"	2560 mm	9'4"
Hopper Capacity	6.2 m <sup>3</sup>	219 ft <sup>3</sup>	6.5 m <sup>3</sup>	230 ft <sup>3</sup>	6.1 m <sup>3</sup>	215 ft <sup>3</sup>
Auger Diameter	406 mm	16"	406 mm	16"	406 mm	16"
Available Screens:						
AS3251C	X		X		—	
Extend-A-Mat 10-20B	—		—		X	
AS2252C	X		X		—	
AS2301	—		—		X	
AS2302	—		—		X	
Service Refill Capacities:						
Cooling System	30 L	7.9 U.S. gal	30 L	8 U.S. gal	36 L	9.5 U.S. gal
Fuel Tank	189 L	50 U.S. gal	291 L	77 U.S. gal	446 L	118 U.S. gal
Hydraulic Oil Tank	170 L	45 U.S. gal	218 L	58 U.S. gal	149 L	39.4 U.S. gal

\*Shipping width with hoppers raised and without end gates.

# Asphalt Pavers

## Specifications

- Barber-Greene
- Track Models



MODEL	BG555E		BG655D		BG-2455D	
Gross Power	106 kW	142 hp	129 kW	174 hp	167 kW	224 hp
Rated Engine RPM	2200		2200		2200	
No. Cylinders	4		6		6	
Displacement	4.4 L	439 in <sup>3</sup>	6.6 L	403 in <sup>3</sup>	7.24 L	441.7 in <sup>3</sup>
Engine Model	C4.4 with ACERT Technology		C6.6 with ACERT Technology		C7 with ACERT Technology	
Operating Weight:						
Tractor						
with Mobil-trac™	13 305 kg	29,335 lb	15 320 kg	33,775 lb	17 601 kg	37,580 lb
with Steel Track	N/A		15 320 kg	33,775 lb	16 601 kg	36,600 lb
Speeds:						
Paving (Mobil-trac™)	61 m/min	200 ft/min	0-70 m/min	0-230 ft/min	67 m/min	220 ft/min
(Steel Track)	N/A		0-78 m/min	0-255 ft/min	78 m/min	255 ft/min
Travel (Mobil-trac™)	11 km/h	7 mph	0-14.5 km/h	0-9 mph	15 km/h	9 mph
(Steel Track)	N/A		0-8 km/h	0-5 mph	8 km/h	5 mph
Tracks Assemblies:						
Width (Mobil-trac™)	406 mm	16"	406 mm	16"	457 mm	18"
(Steel Track)	N/A		356 mm	14"	356 mm	14"
Length on Ground (Mobil-trac™)	2460 mm	8'1"	3020 mm	9'11"	3023 mm	9'11"
(Steel Track)	N/A		3048 mm	10'0"	3048 mm	10'0"
Total Number of Track Pads (Steel Track)	N/A		92		—	
Dimensions:						
Standard Paving Width	2440 mm	8'0"	2440 mm	8'0"	3000 mm	10'0"
Shipping Width (maximum)*	2440 mm	8'0"	2440 mm	8'0"	3380 mm	11'1"
Height (less exhaust)	2820 mm	9'3"	2820 mm	9'3"	2820 mm	9'3"
Length (screed, push roller):						
with AS2252C Screed	5.80 m	19'0"	6650 mm	21'7"	6540 mm	21'6"
with AS3251C Screed	6.11 m	20'0"	6800 mm	22'4"	6540 mm	21'6"
Turning Radius	304 mm	12"	—		914 mm	3'0"
Hopper Capacity	6.2 m <sup>3</sup>	219 ft <sup>3</sup>	—		6.1 m <sup>3</sup>	215 ft <sup>3</sup>
Auger Diameter	406 mm	16"	—		406 mm	16"
Available Screens:						
AS2252C	X		X		—	
Extend-A-Mat 10-20B	—		—		X	
AS3251C	X		X		—	
AS2301	—		—		X	
AS2302	—		—		X	
Service Refill Capacities:						
Cooling System	30 L	7.9 U.S. gal	30 L	8 U.S. gal	36 L	9.5 U.S. gal
Fuel Tank	189 L	50 U.S. gal	291 L	77 U.S. gal	413 L	109 U.S. gal
Hydraulic Oil Tank	170 L	45 U.S. gal	218 L	58 U.S. gal	149 L	39.4 U.S. gal

\*Transport width with hoppers raised, without end gates, and with Extend-A-Mat screed.

MODEL	Extend-A-Mat 10-20B		AS2252C		AS2301		AS2302	
	Standard Paving Width	3050 mm	10'0"	2500 mm	8'2"	3050 mm	10'0"	3050 mm
Paving Ranges:								
Hydraulically Extendible (maximum)	5940 mm	19'6"	4400 mm	14'5"	5500 mm	18'0"	5500 mm	18'0"
With Bolt-on Extensions (maximum)	7370 mm	24'2"	5600 mm	18'5"	7300 mm	24'0"	6705 mm	22'0"
With Cutoff Shoes (minimum)	2440 mm	8'0"	1880 mm	6'2"	2440 mm	8'0"	2440 mm	8'0"
Length:								
Without End Gates (front to rear)	1780 mm	5'10"	1300 mm	4'4"	1480 mm	4'10"	1320 mm	4'4"
With End Gates (front to rear)	2260 mm	7'5"	2060 mm	6'9"	1930 mm	6'4"	2057 mm	6'9"
Width:								
Without End Gates	3050 mm	10'0"	2740 mm	8'11"	3230 mm	10'7"	3276 mm	10'9"
With End Gates	3330 mm	10'11"	2760 mm	9'0"	3380 mm	11'1"	3302 mm	10'10"
Height	2260 mm	7'5"	1400 mm	4'7"	2310 mm	7'7"	2286 mm	7'6"
Weights:								
Diesel Heat Screed	3431 kg	7550 lb	—	—	3355 kg	7840 lb	—	—
Electric Heat Screed	3269 kg	7200 lb	2721 kg	6000 lb	3541 kg	7800 lb	3084 kg	6800 lb

MODEL	AS3251C		AS4251*		AS4251C*		AS4252C	
	Standard Paving Width	2440 mm	8'0"	2550 mm	8'4"	2550 mm	8'4"	2550 mm
Paving Ranges:								
Hydraulically Extendible (maximum)	4750 mm	15'6"	5000 mm	16'5"	5000 mm	16'5"	5000 mm	16'5"
With Bolt-on Extensions (maximum)	6150 mm	20'2"	7840 mm	25'9"	8000 mm	26'3"	8000 mm	26'3"
With Cutoff Shoes (minimum)	1830 mm	6'0"	—	—	—	—	—	—
Tamper System	—	—	X	X	X	X	X	X
Vibration System	—	—	X	X	X	X	X	X
Length:								
Without End Gates (front to rear)	1780 mm	5'10"	1580 mm	5'6"	1580 mm	5'6"	1580 mm	5'6"
With End Gates (front to rear)	2080 mm	6'10"	2260 mm	7'5"	2260 mm	7'5"	2260 mm	7'5"
Width:								
Without End Gates	2460 mm	8'0"	2550 mm	8'2"	2550 mm	8'2"	2550 mm	8'2"
With End Gates	2700 mm	8'10"	2730 mm	8'11"	2730 mm	8'11"	2730 mm	8'11"
Height	2150 mm	7'1"	1520 mm	5'0"	1520 mm	5'0"	1520 mm	5'0"
Weights:								
Diesel Heat Screed	—	—	4000 kg	8820 lb	3840 kg	8467 lb	—	—
Electric Heat Screed	2925 kg	6450 lb	4000 kg	8820 lb	3840 kg	8467 lb	3395 kg	7485 lb

\*Model available to Europe, Africa, Middle East, Australia, and Asia only.



**ASPHALT PAVING CHARTS**

These charts will assist you when trying to match plant output with paving speeds. Keep in mind when using these charts, it will be at 100% efficiency. If you know efficiency, multiply T.P. hour × efficiency. (Example: 75% efficiency at 300 T.P.H. – 300 × 0.75 = 225 T.P.H.)

**Production in tons/hr with 1" compacted mat**

Speed	Paving Widths						
ft/min	6'0"	7'0"	8'0"	9'0"	10'0"	11'0"	12'0"
10	22	26	29	33	37	40	44
20	44	51	58	66	73	80	88
30	66	77	87	99	110	120	131
40	88	102	116	131	146	161	175
50	110	129	145	164	183	201	219

**Production in tons/hr with 2" compacted mat**

Speed	Paving Widths						
ft/min	6'0"	7'0"	8'0"	9'0"	10'0"	11'0"	12'0"
10	44	52	58	66	74	80	88
20	88	176	116	132	146	160	176
30	132	154	174	198	220	240	262
40	176	204	232	262	292	322	350
50	220	258	290	328	366	402	438

**Production in tons/hr with 3" compacted mat**

Speed	Paving Widths						
ft/min	6'0"	7'0"	8'0"	9'0"	10'0"	11'0"	12'0"
10	66	78	87	99	111	120	132
20	132	153	174	198	219	240	284
30	198	231	261	297	330	360	393
40	264	306	348	393	438	483	525
50	330	387	435	492	549	603	657

**Production in tons/hr with 4" compacted mat**

Speed	Paving Widths						
ft/min	6'0"	7'0"	8'0"	9'0"	10'0"	11'0"	12'0"
10	88	104	116	132	148	160	176
20	176	204	232	264	292	320	352
30	264	308	348	396	440	480	524
40	352	408	464	524	584	644	700
50	440	516	580	656	732	804	876

**Slope Conversion Table**

Percent	Inches per foot	Inches per 12 foot	Percent	Inches per foot	Inches per 12 foot
0.17%		¼	5.21%	⅝	7½
0.35%		½	5.38%		7¾
0.52%	⅛	¾	5.56%		8
0.70%		1	5.73%	1¼	8¼
0.87%		1¼	5.90%		8½
1.04%	⅜	1½	6.08%		8¾
1.22%		1¾	6.25%	¾	9
1.39%		2	6.42%		9¼
1.56%	⅜	2¼	6.60%		9½
1.74%		2½	6.77%	1⅜	9¾
1.91%		2¾	6.94%		10
2.08%	¼	3	7.12%		10¼
2.26%		3¼	7.29%	⅞	10½
2.43%		3½	7.47%		10¾
2.60%	⅝	3¾	7.64%		11
2.78%		4	7.81%	1⅝	11¼
2.95%		4¼	7.99%		11½
3.13%	⅝	4½	8.16%		11¾
3.30%		4¾	8.33%	1	12
3.47%		5	8.51%		12¼
3.65%	⅞	5¼	8.68%		12½
3.82%		5½	8.85%	1⅞	12¾
3.99%		5¾	9.03%		13
4.17%	½	6	9.20%		13¼
4.34%		6¼	9.38%	1⅞	13½
4.51%		6½	9.55%		13¾
4.69%	⅞	6¾	9.72%		14
4.86%		7	9.90%	1⅞	14¼
5.04%		7¼	10.07%		14½

**Formula:**

$$\text{Percent} = \frac{\text{Inches per foot} \times 100}{12}$$

**Inches in decimals of a foot**

⅛ = .0052	1 = .0833
⅜ = .0078	2 = .1667
⅝ = .0104	3 = .2500
⅞ = .0156	4 = .3333
¼ = .0208	5 = .4167
⅜ = .0260	6 = .5000
⅝ = .0313	7 = .5833
¾ = .0417	8 = .6667
⅞ = .0521	9 = .7500
⅞ = .0625	10 = .8333
⅞ = .0729	11 = .9167

## Vibratory and Pneumatic Tire Compactors

### Sustainability:

- Long-lasting lubricants and fluids extend maintenance intervals, decreasing the amount of waste and filters contributed to environment.
- Ecology drains provide a simple means to drain machine fluids with a minimized risk of spillage.
- Maintenance free Cat batteries are recyclable.
- Models that are equipped with engines featuring ACERT Technology contribute fewer emissions to the environment.
- Biodegradable oil option available.

### General Compactor Features:

- **Routine maintenance** simplified by grouped service points and easy access to service areas.
- **Operator stations** designed for maximum comfort, easy control, and optimal visibility.
- **Direct hydrostatic drive to front (drums or wheels) and rear (drums or wheels)** provides dependable, responsive, propulsion effort and maximum gradeability. (Does not include pneumatic tire compactors.)

### Vibratory Compactor Features:

#### Single Drum

- **Hydraulic flow divider valve (CS323C/CP323C) or dual pump system** delivers positive tractive effort to both drum and rear wheels, regardless of underfooting. This increases the machine's ability to maneuver in a wide variety of soil types and conditions and improves gross gradeability.
- **Limited slip high traction differential** is standard on all units for best traction of rear tires.
- **Optional heavy-duty front-mounted blade** with reversible cutting edge is available to allow backfilling and leveling during compaction.
- **ROPS (Roll Over Protective Structure)** standard on all units. Enclosed cabs with EROPS rating available as an option (except for CS323C/CP323C).
- **Adjustable jaw-type cleaner bar** keeps drums clean between pads during forward and reverse movement.

#### Double Drum and Combi

- **Vibration automatically ceases before machine comes to a stop** to help produce a smooth, flawless mat surface.
- **Close side clearances** allow compactors to work close to curbs, walls and other obstructions.
- **Large, rust-proof water tanks and pressure spray system** provide hours of reliable operation between fill-ups.
- **Emulsion system** available for combi compactor rear tires to prevent materials sticking to tires.
- **ROPS (Roll Over Protective Structure)** available on all models. Enclosed cabs with EROPS rating available on some models.

### Pneumatic Tire Compactor Features:

- **All wheel oscillation.** Front and rear tires provide even wheel loads regardless of evenness underfoot. PF models have front oscillation only.
- **High drive propel system.** Completely hydrostatic with drive motors and brakes located in mainframe away from contamination and damage.
- **Ballast compartments** are easily accessible for quick loading and are located to provide balanced wheel/weight ratio.
- **Single-lever hand control** of forward and reverse movement makes smooth rolling easy.

**NOTE: All models and options are not available in all markets.**

Specifications  
● Single Drum, Smooth

Vibratory Compactors



MODEL	CS323C <sup>1</sup>		CS423E <sup>2,3</sup>		CS433E <sup>1,2,3</sup>		CS44 <sup>2,3,5</sup>	
Gross Power	62 kW	83 hp	62 kW	83 hp	75 kW	100 hp	75 kW	100 hp
Rated Engine RPM	2200		2200		2200		2200	
No. Cylinders	4		4		4		4	
Displacement	4.4 L	269 in <sup>3</sup>	4.4 L	269 in <sup>3</sup>	4.4 L	269 in <sup>3</sup>	4.4 L	269 in <sup>3</sup>
Engine Model	3054C		3054C		3054C		C4.4 with ACERT Technology	
Speeds	1 forward/1 reverse		2 forward/2 reverse		2 forward/2 reverse		—	
Max. Speed (For./Rev.)	8.9 km/h	5.5 mph	11.5 km/h	7.1 mph	11.5 km/h	7.1 mph	12.3 km/h	7.6 mph
Working Speed	8.9 km/h	5.5 mph	5.5 km/h	3.4 mph	5.5 km/h	3.4 mph	5.5 km/h	3.4 mph
Operating Weight <sup>4</sup>	4390 kg	9680 lb	6745 kg	14,875 lb	6745 kg	14,875 lb	6900 kg	15,212 lb
Shipping Weight <sup>4</sup>	4231 kg	9505 lb	6665 kg	14,700 lb	6665 kg	14,700 lb	6820 kg	25,037 lb
Drive	Drum/Rear Wheel		Drum/Rear Wheel		Drum/Rear Wheel		Drum/Rear Wheel	
Steering:								
Inside Radius	2625 mm	8'7"	3050 mm	10'0"	3050 mm	10'0"	3080 mm	10'1"
Outside Radius	3895 mm	12'9"	4730 mm	15'6"	4730 mm	15'6"	4750 mm	15'7"
Steering Angle	±38°		±37°		±37°		±37°	
Vibratory System:								
Ecc. Weight Drive	Hydraulic		Hydraulic		Hydraulic		Hydraulic	
Frequency	35 Hz	2100 vpm	31.9 Hz	1915 vpm	31.9 Hz	1915 vpm	31.9 Hz	1914 vpm
Amplitude:	1		2		2		—	
High Amplitude	1.30 mm	0.05"	1.67 mm	0.066"	1.67 mm	0.066"	1.67 mm	0.066"
Low Amplitude	—		0.84 mm	0.033"	0.84 mm	0.033"	0.84 mm	0.033"
Centrifugal Force:								
Maximum	66.8 kN	15,000 lb	133.5 kN	30,000 lb	133.5 kN	30,000 lb	134 kN	30,000 lb
Minimum	—		66.8 kN	15,000 lb	66.8 kN	15,000 lb	67 kN	15,000 lb
General Dimensions:								
Overall Width w/Blade	1575 mm	5'2"	—		2100 mm	6'11"	2120 mm	6'11"
Overall Width w/o Blade	1393 mm	4'6"	1800 mm	5'11"	1800 mm	5'11"	1800 mm	5'11"
Drum Width	1270 mm	4'2"	1680 mm	5'6"	1680 mm	5'6"	1680 mm	5'6"
Drum Diameter	1016 mm	3'4"	1220 mm	4'0"	1220 mm	4'0"	1221 mm	4'0"
Tires	11.2 × 24–6 ply		14.9 × 24–6 ply		14.9 × 24–6 ply		14.9 × 24–6 ply	
Overall Height	2514 mm	8'2"	2930 mm	9'7"	2930 mm	9'7"	2930 mm	9'7"
Wheel to Drum	2240 mm	7'4"	2600 mm	8'6"	2600 mm	8'6"	2600 mm	8'6"
Overall Length	4095 mm	13'5"	4960 mm	16'3"	4960 mm	16'3"	5080 mm	16'8"
Curb Clearance	335 mm	13.2"	375 mm	14.8"	375 mm	14.8"	380 mm	14.9"
Service Refill Capacities:								
Fuel Tank	144 L	38 U.S. gal	153 L	40.4 U.S. gal	153 L	40.4 U.S. gal	180 L	47.5 U.S. gal
Crankcase	6.8 L	1.8 U.S. gal	6.8 L	1.8 U.S. gal	6.8 L	1.8 U.S. gal	8.5 L	2.2 U.S. gal
Hydraulic Fluid	49.2 L	13 U.S. gal	60 L	16 U.S. gal	60 L	16 U.S. gal	80 L	21.1 U.S. gal

<sup>1</sup>Leveling blade available.

<sup>2</sup>Padfoot shell kit available.

<sup>3</sup>Variable frequency vibration available.

<sup>4</sup>With ROPS/FOPS canopy.

<sup>5</sup>Leveling blade available on machines equipped with padfoot shell kit.

# Vibratory Compactors

## Specifications

- Single Drum, Smooth



MODEL	CS533E <sup>2,3,5</sup>		CS54 <sup>2,3</sup>		CS56 <sup>1,2,3,4</sup>		CS64 <sup>1,2,3,4</sup>	
Gross Power	97 kW	<b>130 hp</b>	97 kW	<b>130 hp</b>	116 kW	<b>156 hp</b>	116 kW	<b>156 hp</b>
Rated Engine RPM	<b>2200</b>		<b>2200</b>		<b>2200</b>		<b>2200</b>	
No. Cylinders	<b>4</b>		<b>4</b>		<b>6</b>		<b>6</b>	
Displacement	4.4 L	<b>269 in<sup>3</sup></b>	4.4 L	<b>269 in<sup>3</sup></b>	6.6 L	<b>403 in<sup>3</sup></b>	6.6 L	<b>403 in<sup>3</sup></b>
Engine Model	<b>3054C</b>		<b>C4.4 with ACERT Technology</b>		<b>C6.6 with ACERT Technology</b>		<b>C6.6 with ACERT Technology</b>	
Speeds	<b>2 forward/2 reverse</b>		<b>2 forward/2 reverse</b>		<b>2 forward/2 reverse</b>		<b>2 forward/2 reverse</b>	
Max. Speed (For./Rev.)	12 km/h	<b>7.5 mph</b>	11.1 km/h	<b>6.9 mph</b>	11.4 km/h	<b>7 mph</b>	11.4 km/h	<b>7 mph</b>
Working Speed	8 km/h	<b>4.9 mph</b>	5.8 km/h	<b>3.6 mph</b>	5.7 km/h	<b>3.5 mph</b>	5.7 km/h	<b>3.5 mph</b>
Operating Weight <sup>4</sup>	10 485 kg	<b>23,120 lb</b>	10 485 kg	<b>23,120 lb</b>	11 414 kg	<b>25,164 lb</b>	14 238 kg	<b>31,389 lb</b>
Shipping Weight	10 405 kg	<b>22,945 lb</b>	10 405 kg	<b>22,945 lb</b>	11 334 kg	<b>24,989 lb</b>	14 158 kg	<b>31,213 lb</b>
Drive	<b>Drum/Rear Wheel</b>		<b>Drum/Rear Wheel</b>		<b>Drum/Rear Wheel</b>		<b>Drum/Rear Wheel</b>	
Steering:								
Inside Radius	3680 mm	<b>12'1"</b>	3680 mm	<b>12'1"</b>	3680 mm	<b>12'1"</b>	3680 mm	<b>12'1"</b>
Outside Radius	5810 mm	<b>19'1"</b>	5810 mm	<b>19'1"</b>	5810 mm	<b>19'1"</b>	5810 mm	<b>19'1"</b>
Steering Angle	<b>±34°</b>		<b>±34°</b>		<b>±34°</b>		<b>±34°</b>	
Vibratory System:								
Ecc. Weight Drive	<b>Hydraulic</b>		<b>Hydraulic</b>		<b>Hydraulic</b>		<b>Hydraulic</b>	
Frequency	31 Hz	<b>1860 vpm</b>	31 Hz	<b>1860 vpm</b>	31.9 Hz	<b>1914 vpm</b>	31.9 Hz	<b>1914 vpm</b>
Amplitude:		<b>2</b>		<b>2</b>		<b>2</b>		<b>2</b>
High Amplitude	1.80 mm	<b>0.071"</b>	1.80 mm	<b>0.071"</b>	1.80 mm	<b>0.07"</b>	1.80 mm	<b>0.07"</b>
Low Amplitude	0.85 mm	<b>0.033"</b>	0.85 mm	<b>0.033"</b>	0.90 mm	<b>0.035"</b>	0.90 mm	<b>0.035"</b>
Centrifugal Force:								
Maximum	234 kN	<b>52,600 lb</b>	234 kN	<b>52,600 lb</b>	282 kN	<b>63,300 lb</b>	282 kN	<b>63,300 lb</b>
Minimum	133 kN	<b>30,000 lb</b>	133 kN	<b>30,000 lb</b>	141 kN	<b>31,600 lb</b>	141 kN	<b>31,600 lb</b>
General Dimensions:								
Overall Width w/Blade	—		—		2500 mm	<b>8'3"</b>	2500 mm	<b>8'3"</b>
Overall Width w/o Blade	2286 mm	<b>7'6"</b>	2286 mm	<b>7'6"</b>	2290 mm	<b>7'6"</b>	2370 mm	<b>7'9"</b>
Drum Width	2130 mm	<b>7'0"</b>	2130 mm	<b>7'0"</b>	2130 mm	<b>7'0"</b>	2130 mm	<b>7'0"</b>
Drum Diameter	1534 mm	<b>5'0"</b>	1534 mm	<b>5'0"</b>	1524 mm	<b>5'0"</b>	1534 mm	<b>5'0"</b>
Tires	<b>23.1 × 26–8 ply flotation</b>		<b>23.1 × 26–8 ply flotation</b>		<b>23.1 × 26–8 ply flotation</b>		<b>23.1 × 26–8 ply flotation</b>	
Overall Height <sup>5</sup>	3070 mm	<b>10'1"</b>	3070 mm	<b>10'1"</b>	3070 mm	<b>10'1"</b>	3070 mm	<b>10'1"</b>
Wheel to Drum	2900 mm	<b>9'6"</b>	2900 mm	<b>9'6"</b>	2900 mm	<b>9'6"</b>	2900 mm	<b>9'6"</b>
Overall Length	5510 mm	<b>18'1"</b>	5.57 m	<b>18'3"</b>	5.86 m	<b>19'3"</b>	5.97 m	<b>19'7"</b>
Curb Clearance	521 mm	<b>20.5"</b>	516 mm	<b>20.3"</b>	490 mm	<b>19.3"</b>	490 mm	<b>19.3"</b>
Service Refill Capacities:								
Fuel Tank	180 L	<b>47 U.S. gal</b>	200 L	<b>53 U.S. gal</b>	345 L	<b>91 U.S. gal</b>	345 L	<b>91 U.S. gal</b>
Crankcase	9 L	<b>2.4 U.S. gal</b>	8.5 L	<b>2.25 U.S. gal</b>	17.4 L	<b>4.6 U.S. gal</b>	17.4 L	<b>4.6 U.S. gal</b>
Hydraulic Fluid	60 L	<b>16 U.S. gal</b>	60 L	<b>16 U.S. gal</b>	90 L	<b>23.8 U.S. gal</b>	90 L	<b>23.8 U.S. gal</b>

<sup>1</sup>Leveling blade available.

<sup>2</sup>Padfoot shell kit available.

<sup>3</sup>Variable frequency vibration available.

<sup>4</sup>AccuGrade compaction available.

<sup>5</sup>With ROPS/FOPS canopy.

Specifications  
 • Single Drum, Smooth

Vibratory Compactors



MODEL	CS74 <sup>1,2,3,4</sup>		CS76 <sup>1,3,4</sup>		CS76 XT <sup>1,3,4</sup>	
Gross Power	116 kW	156 hp	130 kW	174 hp	130 kW	174 hp
Rated Engine RPM	2200		2200		2200	
No. Cylinders	6		6		6	
Displacement	6.6 L	403 in <sup>3</sup>	6.6 L	403 in <sup>3</sup>	6.6 L	403 in <sup>3</sup>
Engine Model	C6.6 with ACERT Technology		C6.6 with ACERT Technology		C6.6 with ACERT Technology	
Speeds	2 forward/2 reverse		2 forward/2 reverse		2 forward/2 reverse	
Max. Speed (For./Rev.)	11.4 km/h	7 mph	11.4 km/h	7 mph	11.4 km/h	7 mph
Working Speed	5.7 km/h	3.5 mph	5.7 km/h	3.5 mph	5.7 km/h	3.5 mph
Operating Weight <sup>2</sup>	15 455 kg	34,072 lb	16 758 kg	36,945 lb	18 611 kg	41,030 lb
Shipping Weight	15 375 kg	33,902 lb	16 678 kg	36,775 lb	18 531 kg	40,854 lb
Drive	Drum/Rear Wheel		Drum/Rear Wheel		Drum/Rear Wheel	
Steering:						
Inside Radius	3680 mm	12'1"	3680 mm	12'1"	3680 mm	12'1"
Outside Radius	5810 mm	19'1"	5810 mm	19'1"	5810 mm	19'1"
Steering Angle	±34°		±34°		±34°	
Vibratory System:						
Ecc. Weight Drive	Hydraulic		Hydraulic		Hydraulic	
Frequency	30 Hz	1800 vpm	30 Hz	1800 vpm	30 Hz	1800 vpm
Amplitude:	2		2		2	
High Amplitude	1.8 mm	0.070"	1.8 mm	0.070"	1.8 mm	0.070"
Low Amplitude	0.9 mm	0.035"	0.9 mm	0.035"	0.9 mm	0.035"
Centrifugal Force:						
Maximum	332 kN	74,600 lb	332 kN	74,600 lb	332 kN	74,600 lb
Minimum	166 kN	37,300 lb	166 kN	37,300 lb	166 kN	37,300 lb
General Dimensions:						
Overall Width w/o Blade	2370 mm	7'9"	2340 mm	7'8"	2370 mm	7'9"
Drum Width	2130 mm	7'0"	2130 mm	7'0"	2130 mm	7'0"
Drum Diameter	1534 mm	5'0"	1534 mm	5'0"	1534 mm	5'0"
Tires	23.1 × 26-8 ply flotation		23.1 × 26-12 ply flotation		23.1 × 26-12 ply flotation	
Overall Height <sup>5</sup>	3070 mm	10'1"	3070 mm	10'1"	3070 mm	10'1"
Wheel to Drum	2900 mm	9'6"	2900 mm	9'6"	2900 mm	9'6"
Overall Length	5970 mm	19'7"	6130 mm	20'1"	6130 mm	20'1"
Curb Clearance	490 mm	19.3"	490 mm	19.3"	490 mm	19.3"
Service Refill Capacities:						
Fuel Tank	345 L	91 U.S. gal	345 L	91 U.S. gal	345 L	91 U.S. gal
Crankcase	17.4 L	4.6 U.S. gal	17.4 L	4.6 U.S. gal	17.4 L	4.6 U.S. gal
Hydraulic Fluid	90 L	23.8 U.S. gal	90 L	23.8 U.S. gal	90 L	23.8 U.S. gal

<sup>1</sup>Variable frequency vibration available.

<sup>2</sup>Leveling blade available.

<sup>3</sup>Padfoot shell kit available.

<sup>4</sup>AccuGrade compaction available.

<sup>5</sup>With ROPS/FOPS canopy.

# Vibratory Compactors

## Specifications

### ● Single Drum, Padded



MODEL	CP323C <sup>1</sup>	CP433E <sup>1,2</sup>	CP441 <sup>1,2</sup>
Gross Power	62 kW    83 hp	75 kW    100 hp	75 kW    100 hp
Rated Engine RPM	2200	2200	2200
No. Cylinders	4	4	4
Displacement	4.4 L    269 in <sup>3</sup>	4.4 L    269 in <sup>3</sup>	4.4 L    269 in <sup>3</sup>
Engine Model	3054C	3054C	C4.4 with ACERT Technology
Speeds	1 forward/1 reverse	2 forward/2 reverse	2 forward/2 reverse
Max. Speed (For./Rev.)	8.9 km/h    5.5 mph	11.5 km/h    7.1 mph	12.3 km/h    7.6 mph
Working Speed	8.9 km/h    5.5 mph	5.5 km/h    3.4 mph	5.5 km/h    3.4 mph
Operating Weight <sup>3</sup>	4620 kg    10,190 lb	7145 kg    15,750 lb	7295 kg    16,083 lb
Shipping Weight <sup>3</sup>	4540 kg    10,015 lb	7065 kg    15,600 lb	7215 kg    15,908 lb
Drive	Drum/Rear Wheel	Drum/Rear Wheel	Drum/Rear Wheel
Steering:			
Inside Radius	2625 mm    8'7"	3050 mm    10'0"	3080 mm    10'1"
Outside Radius	3895 mm    12'9"	4730 mm    15'6"	4750 mm    15'7"
Steering Angle	±38°	±37°	±37°
Vibratory System:			
Ecc. Weight Drive	Hydraulic	Hydraulic	Hydraulic
Frequency	35 Hz    2100 vpm	31.9 Hz    1914 vpm	31.9 Hz    1914 vpm
Amplitude:	1	2	2
High Amplitude	1.30 mm    0.05"	1.55 mm    0.061"	1.59 mm    0.063"
Low Amplitude	—	0.78 mm    0.031"	0.80 mm    0.032"
Centrifugal Force:			
Maximum	66.8 kN    15,000 lb	133.5 kN    30,000 lb	134 kN    30,000 lb
Minimum	—	66.8 kN    15,000 lb	67 kN    15,000 lb
General Dimensions:			
Overall Width w/Blade	1575 mm    5'2"	2100 mm    6'11"	2120 mm    6'11"
Overall Width w/o Blade	1393 mm    4'6"	1800 mm    5'11"	1800 mm    5'11"
Drum Width	1270 mm    4'2"	1680 mm    5'6"	1680 mm    5'6"
Drum Diameter over Pads	1016 mm    3'4"	1227 mm    4'0"	1225 mm    4'0"
Tires	11.2 × 24–6 ply traction	14.9 × 24–8 ply traction	14.9 × 24–8 ply
Overall Height <sup>3</sup>	2514 mm    8'2"	2930 mm    9'7"	2930 mm    9'7"
Wheel to Drum	2240 mm    7'4"	2600 mm    8'6"	2600 mm    8'6"
Overall Length	4120 mm    13'6"	4960 mm    16'3"	5080 mm    16'8"
Curb Clearance	335 mm    13.2"	375 mm    15"	380 mm    14.9"
Service Refill Capacities:			
Fuel Tank	144 L    38 U.S. gal	153 L    40 U.S. gal	180 L    47.5 U.S. gal
Crankcase	6.8 L    1.8 U.S. gal	6.8 L    1.8 U.S. gal	8.5 L    2.2 U.S. gal
Hydraulic Fluid	49.2 L    13 U.S. gal	60 L    16 U.S. gal	80 L    21.1 U.S. gal

<sup>1</sup>Leveling blade available.

<sup>2</sup>Variable frequency vibration available.

<sup>3</sup>With ROPS/FOPS canopy.

Specifications  
● Single Drum, Padded

Vibratory Compactors



MODEL	CP533E <sup>2,3</sup>		CP54 <sup>2,4</sup>		CP56 <sup>1,2</sup>	
Gross Power	97 kW	130 hp	97 kW	130 hp	116 kW	156 hp
Rated Engine RPM	2200		2200		2200	
No. Cylinders	4		4		6	
Displacement	4.4 L	269 in <sup>3</sup>	4.4 L	269 in <sup>3</sup>	6.6 L	403 in <sup>3</sup>
Engine Model	3054C		C4.4 with ACERT Technology		C6.6 with ACERT Technology	
Speeds	2 forward/2 reverse		2 forward/2 reverse		2 forward/2 reverse	
Max. Speed (For./Rev.)	12 km/h	7.5 mph	11.1 km/h	6.9 mph	11.4 km/h	7 mph
Working Speed	8 km/h	4.9 mph	5.8 km/h	3.6 mph	5.7 km/h	3.5 mph
Operating Weight <sup>3</sup>	11 320 kg	24,960 lb	11 320 kg	24,960 lb	11 361 kg	25,047 lb
Shipping Weight <sup>3</sup>	11 240 kg	24,785 lb	11 240 kg	24,785 lb	11 281 kg	24,875 lb
Drive	Drum/Rear Wheel		Drum/Rear Wheel		Drum/Rear Wheel	
Steering:						
Inside Radius	3680 mm	12'1"	3680 mm	12'1"	3680 mm	12'1"
Outside Radius	5810 mm	19'1"	5810 mm	19'1"	5810 mm	19'1"
Steering Angle	±34°		±34°		±34°	
Vibratory System:						
Ecc. Weight Drive	Hydraulic		Hydraulic		Hydraulic	
Frequency	31.9 Hz	1914 vpm	31.9 Hz	1915 vpm	31.9 Hz	1914 vpm
Amplitude:	2		2		2	
High Amplitude	1.70 mm	0.067"	1.80 mm	0.070"	1.80 mm	0.070"
Low Amplitude	0.85 mm	0.033"	0.90 mm	0.035"	0.90 mm	0.035"
Centrifugal Force:						
Maximum	266 kN	60,000 lb	266 kN	60,000 lb	282 kN	63,300 lb
Minimum	133.5 kN	30,000 lb	133 kN	30,000 lb	141 kN	31,600 lb
General Dimensions:						
Overall Width w/Blade	—		—		2500 mm	8'2"
Overall Width w/o Blade	2286 mm	7'6"	2286 mm	7'6"	2290 mm	7'6"
Drum Width	2130 mm	7'0"	2130 mm	7'0"	2130 mm	7'0"
Drum Diameter over Pads	1549 mm	5'1"	1549 mm	5'1"	1549 mm	5'1"
Tires	23.1 × 26–8 ply traction		23.1 × 26–8 ply traction		23.1 × 26–8 ply traction	
Overall Height <sup>3</sup>	3070 mm	10'1"	3070 mm	10'1"	3070 mm	10'1"
Wheel to Drum	2900 mm	9'6"	2900 mm	9'6"	2900 mm	9'6"
Overall Length	5510 mm	18'1"	5570 mm	18'3"	5860 mm	19'3"
Curb Clearance	521 mm	20.5"	521 mm	20.5"	510 mm	20.1"
Service Refill Capacities:						
Fuel Tank	180 L	47.5 U.S. gal	200 L	53 U.S. gal	345 L	91 U.S. gal
Crankcase	9 L	2.4 U.S. gal	8.5 L	2.25 U.S. gal	17.4 L	4.6 U.S. gal
Hydraulic Fluid	60 L	16 U.S. gal	60 L	16 U.S. gal	90 L	23.8 U.S. gal

<sup>1</sup>Leveling blade available.

<sup>2</sup>Variable frequency vibration available.

<sup>3</sup>With ROPS/FOPS canopy.

<sup>4</sup>Not available to the NACD market.



# Vibratory Compactors

## Specifications

### ● Single Drum, Padded



MODEL	CP64 <sup>1,2</sup>		CP74 <sup>1,2</sup>		CP76 <sup>2</sup>	
Gross Power	116 kW	156 hp	116 kW	156 hp	130 kW	174 hp
Rated Engine RPM	2200		2200		2200	
No. Cylinders	6		6		6	
Displacement	6.6 L	403 in <sup>3</sup>	6.6 L	403 in <sup>3</sup>	6.6 L	403 in <sup>3</sup>
Engine Model	C6.6 with ACERT Technology		C6.6 with ACERT Technology		C6.6 with ACERT Technology	
Speeds	2 forward/2 reverse		2 forward/2 reverse		2 forward/2 reverse	
Max. Speed (For./Rev.)	11.4 km/h	7 mph	11.4 km/h	7 mph	11.4 km/h	7 mph
Working Speed	5.7 km/h	3.5 mph	5.7 km/h	3.5 mph	5.7 km/h	3.5 mph
Operating Weight <sup>3</sup>	14 311 kg	31,550 lb	15 333 kg	33,804 lb	16 896 kg	37,249 lb
Shipping Weight <sup>3</sup>	14 231 kg	31,379 lb	15 253 kg	33,633 lb	16 816 kg	37,073 lb
Drive	Drum/Rear Wheel		Drum/Rear Wheel		Drum/Rear Wheel	
Steering:						
Inside Radius	3680 mm	12'1"	3680 mm	12'1"	3680 mm	12'1"
Outside Radius	5810 mm	19'1"	5810 mm	19'1"	5810 mm	19'1"
Steering Angle	±34°		±34°		±34°	
Vibratory System:						
Ecc. Weight Drive	Hydraulic		Hydraulic		Hydraulic	
Frequency	31.9 Hz	1914 vpm	30 Hz	1800 vpm	30 Hz	1800 vpm
Amplitude:	2		2		2	
High Amplitude	1.80 mm	0.070"	1.80 mm	0.070"	1.80 mm	0.070"
Low Amplitude	0.90 mm	0.035"	0.90 mm	0.035"	0.90 mm	0.035"
Centrifugal Force:						
Maximum	282 kN	63,300 lb	332 kN	74,600 lb	332 kN	74,600 lb
Minimum	141 kN	31,600 lb	166 kN	37,300 lb	166 kN	37,300 lb
General Dimensions:						
Overall Width w/Blade	2500 mm	8'2"	2500 mm	8'2"	—	
Overall Width w/o Blade	2370 mm	7'9"	2370 mm	7'9"	2370 mm	7'9"
Drum Width	2130 mm	7'0"	2130 mm	7'0"	2130 mm	7'0"
Drum Diameter over Pads	1549 mm	5'1"	1549 mm	5'1"	1549 mm	5'1"
Tires	23.1 × 26–8 ply traction		23.1 × 26 8–ply traction		23.1 × 26–12 ply traction	
Overall Height <sup>3</sup>	3070 mm	10'1"	3070 mm	10'1"	3070 mm	10'1"
Wheel to Drum	2900 mm	9'6"	2900 mm	9'6"	2900 mm	9'6"
Overall Length	5970 mm	19'7"	5970 mm	19'7"	6130 mm	20'1"
Curb Clearance	510 mm	20.1"	510 mm	20.1"	510 mm	20.1"
Service Refill Capacities:						
Fuel Tank	345 L	91 U.S. gal	345 L	91 U.S. gal	345 L	91 U.S. gal
Crankcase	17.4 L	4.6 U.S. gal	17.4 L	4.6 U.S. gal	17.4 L	4.6 U.S. gal
Hydraulic Fluid	90 L	23.8 U.S. gal	90 L	23.8 U.S. gal	90 L	23.8 U.S. gal

<sup>1</sup>Leveling blade available.

<sup>2</sup>Variable frequency vibration available.

<sup>3</sup>With ROPS/FOPS canopy.

Specifications

Vibratory Compactors

• Double Drum and Combi



MODEL	CB14		CB14 XW		CB14 Full Flush	
Gross Power	16.1 kW	21.6 hp	16.1 kW	21.6 hp	16.1 kW	21.6 hp
Rated Engine RPM	2400		2400		2400	
No. Cylinders	3		3		3	
Displacement	1131 cm <sup>3</sup>	60.8 in <sup>3</sup>	1131 cm <sup>3</sup>	60.8 in <sup>3</sup>	1131 cm <sup>3</sup>	60.8 in <sup>3</sup>
Engine Model	C1.1		C1.1		C1.1	
Speeds	Variable		Variable		Variable	
Max. Speed (For./Rev.)	8.5 km/h	5 mph	8.5 km/h	5 mph	8.5 km/h	5 mph
Working Speed	0-8.5 km/h	0-5 mph	0-8.5 km/h	0-5 mph	0-8.5 km/h	0-5 mph
Operating Weight <sup>1</sup>	1620 kg	3571 lb	1840 kg	4057 lb	1600 kg	3527 lb
Drive	Hydraulic		Hydraulic		Hydraulic	
Steering:						
Inside Radius:	2650 mm	8'8"	2600 mm	8'6"	—	—
Left Side	—	—	—	—	2650 mm	8'8"
Right Side	—	—	—	—	2600 mm	8'6"
Outside Radius:	3050 mm	10'0"	3080 mm	10'1"	—	—
Left Side	—	—	—	—	3100 mm	10'2"
Right Side	—	—	—	—	3050 mm	10'0"
Steering Angle	±32°		±32°		±32°	
Vibratory System:						
Ecc. Weight Drive	Hydraulic		Hydraulic		Hydraulic	
Frequency (Max.)	53.3 Hz	3200 vpm	53.3 Hz	3200 vpm	53.3 Hz	3200 vpm
Amplitude:						
High Amplitude	0.40 mm	0.016"	0.40 mm	0.016"	0.40 mm	0.016"
Centrifugal Force:						
High Amplitude	10.3 kN	2318 lb	11.4 kN	2565 lb	10.3 kN	2318 lb
General Dimensions:						
Overall Width	884 mm	34"	1084 mm	42"	960 mm	37"
Drum Width	800 mm	31"	1000 mm	39"	900 mm	35"
Drum Diameter	575 mm	22.5"	575 mm	22.5"	575 mm	22.5"
Overall Height (ROPS)	2400 mm	7'10"	2400 mm	7'10"	2400 mm	7'10"
Wheelbase	1300 mm	4'3"	1300 mm	4'3"	1300 mm	4'3"
Overall Length	2050 mm	6'8"	2050 mm	6'8"	2050 mm	6'8"
Curb Clearance	370 mm	14.5"	370 mm	14.5"	370 mm	14.5"
Ground Clearance	250 mm	10"	250 mm	10"	250 mm	10"
Service Refill Capacities:						
Fuel Tank	30 L	7.9 U.S. gal	30 L	7.9 U.S. gal	30 L	7.9 U.S. gal
Sprinkler Water	150 L	39.6 U.S. gal	150 L	39.6 U.S. gal	150 L	39.6 U.S. gal

<sup>1</sup>With ROPS.

# Vibratory Compactors

## Specifications

### • Double Drum and Combi



MODEL	CB22		CB24		CB32		CC24	
Gross Power	24.6 kW	33 hp	24.6 kW	33 hp	24.6 kW	33 hp	24.6 kW	33 hp
Rated Engine RPM	2800		2800		2800		2800	
No. Cylinders	3		3		3		3	
Displacement	1.5 L	92 in <sup>3</sup>	1.5 L	92 in <sup>3</sup>	1.5 L	92 in <sup>3</sup>	1.5 L	92 in <sup>3</sup>
Engine Model	C1.5		C1.5		C1.5		C1.5	
Max. Speed (For./Rev.)	10.5 km/h	6.5 mph	10.5 km/h	6.5 mph	10.5 km/h	6.5 mph	10.5 km/h	6.5 mph
Operating Weight <sup>1</sup>	2500 kg	5512 lb	2700 kg	5952 lb	3230 kg	7121 lb	2400 kg	5291 lb
Shipping Weight <sup>1</sup>	2421 kg	5337 lb	2620 kg	5777 lb	3150 kg	6946 lb	2320 kg	5116 lb
Drive	Hydraulic		Hydraulic		Hydraulic		Hydraulic	
Steering:								
Inside Radius	2640 mm	104"	2540 mm	100"	2490 mm	98"	2540 mm	100"
Outside Radius	3640 mm	132"	3740 mm	147"	3790 mm	149"	3740 mm	147"
Steering Angle	±35°		±35°		±35°		±35°	
Vibratory System:								
Ecc. Weight Drive	Hydraulic		Hydraulic		Hydraulic		Hydraulic	
Frequency	55 Hz	3300 vpm	55 Hz	3300 vpm	55 Hz	3300 vpm	55 Hz	3300 vpm
Amplitude:		1		1		1		1
High Amplitude	0.50 mm	0.020"	0.50 mm	0.020"	0.30 mm	0.012"	0.50 mm	0.020"
Centrifugal Force:								
High Amplitude	27.6 kg	6210 lb	31.3 kg	7043 lb	31.3 kg	7043 lb	31.3 kg	7043 lb
General Dimensions:								
Overall Width	1098 mm	43"	1298 mm	51"	1398 mm	55"	1298 mm	51"
Drum Width	1000 mm	39"	1200 mm	47"	1300 mm	51"	1200 mm	47"
Drum Diameter	700 mm	27.6"	700 mm	27.6"	700 mm	27.6"	700 mm	27.6"
Tires	—		—		—		9.5 × 65-15, 6 ply	
Overall Height (ROPS)	2680 mm	106"	2680 mm	106"	2680 mm	106"	2673 mm	105"
Wheelbase	1800 mm	71"	1800 mm	71"	1800 mm	71"	1827 mm	72"
Overall Length	2500 mm	98"	2500 mm	98"	2500 mm	98"	2500 mm	98"
Curb Clearance	520 mm	20"	520 mm	20"	520 mm	20"	520 mm	20"
Ground Clearance	262 mm	10"	262 mm	10"	262 mm	10"	262 mm	10"
Service Refill Capacities:								
Fuel Tank	56 L	14.7 U.S. gal	56 L	14.7 U.S. gal	56 L	14.7 U.S. gal	56 L	14.7 U.S. gal
Crankcase	6 L	1.5 U.S. gal	6 L	1.5 U.S. gal	6 L	1.5 U.S. gal	6 L	1.5 U.S. gal
Hydraulic Tank	36.6 L	9.6 U.S. gal	36.6 L	9.6 U.S. gal	36.6 L	9.6 U.S. gal	36.6 L	9.6 U.S. gal
Sprinkler Water	240 L	83.3 U.S. gal	240 L	83.3 U.S. gal	240 L	83.3 U.S. gal	240 L	83.3 U.S. gal

<sup>1</sup>With ROPS.

Specifications  
 • Double Drum and Combi

Vibratory Compactors



MODEL	CB34		CB34 XW		CC34 <sup>2</sup>		CB434D	
Gross Power	34.1 kW	46 hp	34.1 kW	46 hp	34.1 kW	46 hp	62 kW	83 hp
Rated Engine RPM	2400		2400		2400		2200	
No. Cylinders	4		4		4		4	
Displacement	2216 cm <sup>3</sup>	87 in <sup>3</sup>	2216 cm <sup>3</sup>	87 in <sup>3</sup>	2216 cm <sup>3</sup>	87 in <sup>3</sup>	—	
Engine Model	C2.2		C2.2		C2.2		3054C	
Speeds	—		—		—		1 forward/1 reverse	
Max. Speed (For./Rev.)	12.5 km/h	8 mph	12.5 km/h	8 mph	12.5 km/h	8 mph	11.6 km/h	7 mph
Working Speed	—		—		—		0-11.6 km/h	0-7 mph
Operating Weight <sup>1</sup>	3940 kg	8688 lb	4200 lb	9259 lb	3670 kg	8091 lb	7500 kg	16,535 lb
Shipping Weight <sup>1</sup>	3861 kg	8512 lb	4120 lb	9083 lb	3590 lb	7915 lb	7420 kg	16,360 lb
Drive	Hydraulic		Hydraulic		Hydraulic		Hydraulic	
Steering:	—		—		—		—	
Inside Radius	3000 mm	118"	2950 mm	116"	3000 mm	118"	3500 mm	11'6"
Outside Radius	4300 mm	169"	4350 mm	171"	4300 mm	169"	5000 mm	16'5"
Steering Angle	±35°		±35°		±35°		±35°	
Vibratory System:	—		—		—		—	
Ecc. Weight Drive	Hydraulic		Hydraulic		Hydraulic		Hydraulic	
Frequency	69/ 61 Hz	4140/ 3660 vpm	53/ 48 Hz	3180/ 2880 vpm	69/ 61 Hz	4140/ 3660 vpm	53 Hz	3200 vpm
Amplitude:	—		—		—		5	
High Amplitude	0.37 mm	0.015"	0.50 mm	0.020"	0.37 mm	0.015"	0.68 mm	0.027"
Low Amplitude	—		—		—		0.25 mm	0.010"
Centrifugal Force:	—		—		—		—	
High Amplitude	33.1 kN	7448 lb	29.5 kN	6638 lb	33.1 kN	7448 lb	78 kN	17,550 lb
Low Amplitude	—		—		—		29 kN	6525 lb
General Dimensions:	—		—		—		—	
Overall Width	1390 mm	55"	1490 mm	58"	1390 mm	55"	1670 mm	5'6"
Drum Width	1300 mm	51"	1400 mm	55"	1300 mm	51"	1500 mm	4'11"
Drum Diameter	800 mm	31"	800 mm	31"	800 mm	31"	1100 mm	3'7"
Tires	—		—		6 ply		—	
Overall Height (ROPS)	2560 mm	100"	2560 mm	100"	2560 mm	100"	3010 mm	9'11"
Wheelbase	2320 mm	91"	2320 mm	91"	2320 mm	91"	3100 mm	10'2"
Overall Length	3120 mm	123"	3120 mm	123"	3120 mm	123"	4200 mm	13'9"
Curb Clearance	602 mm	23.5"	602 mm	23.5"	602 mm	23.5"	720 mm	28"
Ground Clearance	284 mm	11"	284 mm	11"	284 mm	11"	255 mm	10"
Service Refill Capacities:	—		—		—		—	
Fuel Tank	57 L	15 U.S. gal	57 L	15 U.S. gal	57 L	15 U.S. gal	132 L	35 U.S. gal
Crankcase	10.6 L	2.8 U.S. gal	10.6 L	2.8 U.S. gal	10.6 L	2.8 U.S. gal	9 L	2.4 U.S. gal
Hydraulic Tank	48 L	12.7 U.S. gal	48 L	12.7 U.S. gal	48 L	12.7 U.S. gal	50 L	13.2 U.S. gal
Sprinkler Water	300 L	79 U.S. gal	300 L	79 U.S. gal	300 L	79 U.S. gal	800 L	211 U.S. gal

<sup>1</sup>With ROPS.

<sup>2</sup>Combi Asphalt Compactor with steel front drum and rubber tires at the rear.

# Vibratory Compactors

## Specifications

### ● Double Drum and Combi



MODEL	CB434D XW		CB54		CB54 XW	
Gross Power	62 kW	83 hp	102 kW	137 hp	102 kW	137 hp
Rated Engine RPM	2200		2200		2200	
No. Cylinders	4		4		4	
Displacement	—		4.4 L	269 in <sup>3</sup>	4.4 L	269 in <sup>3</sup>
Engine Model	3054C		C4.4 with ACERT Technology		C4.4 with ACERT Technology	
Speeds	1 forward/1 reverse		2 forward/2 reverse		2 forward/2 reverse	
Max. Speed (For./Rev.)	11.6 km/h	7 mph	13 km/h	8 mph	13 km/h	8 mph
Working Speed	0-11.6 km/h	0-7 mph	0-13 km/h	0-8 mph	0-13 km/h	0-8 mph
Operating Weight <sup>1</sup>	7700 kg	16,975 lb	10 804 kg	23,818 lb	11 898 kg	26,230 lb
Shipping Weight <sup>1</sup>	7620 kg	16,800 lb	10 724 kg	23,643 lb	11 818 kg	26,055 lb
Drive	Hydraulic		Hydraulic		Hydraulic	
Steering:						
Inside Radius	3400 mm	11'2"	4150 mm	13'7"	4000 mm	13'1"
Outside Radius	5100 mm	16'9"	5850 mm	19'2"	6000 mm	19'8"
Steering Angle	±40°		±40°		±40°	
Vibratory System:						
Ecc. Weight Drive	Hydraulic		Hydraulic		Hydraulic	
Frequency	53 Hz	3200 vpm	42 Hz	2520 vpm	42 Hz	2520 vpm
Amplitude <sup>2</sup> :						
High Amplitude	0.60 mm	0.024"	1.06 mm	0.042"	0.86 mm	0.034"
Low Amplitude	0.22 mm	0.009"	0.33 mm	0.013"	0.30 mm	0.012"
Centrifugal Force:						
High Amplitude	78 kN	17,550 lb	110 kN	24,929 lb	110 kN	24,929 lb
Low Amplitude	29 kN	6525 lb	35 kN	7922 lb	35 kN	7922 lb
General Dimensions:						
Overall Width	1870 mm	6'1"	1905 mm	6'3"	2205 mm	7'3"
Drum Width	1700 mm	5'7"	1700 mm	5'7"	2000 mm	6'7"
Drum Diameter	1100 mm	3'7"	1300 mm	4'3"	1300 mm	4'3"
Overall Height (ROPS)	3010 mm	9'11"	3050 mm	10'1"	3050 mm	10'1"
Wheelbase	3100 mm	10'2"	3640 mm	11'11"	3640 mm	11'11"
Overall Length	4200 mm	13'9"	4934 mm	16'2"	4934 mm	16'2"
Curb Clearance	720 mm	28"	868 mm	34.2"	868 mm	34.2"
Ground Clearance	255 mm	10"	217 mm	8.5"	217 mm	8.5"
Service Refill Capacities:						
Fuel Tank	132 L	35 U.S. gal	191 L	50 U.S. gal	191 L	50 U.S. gal
Crankcase	9 L	2.4 U.S. gal	9 L	2.4 U.S. gal	9 L	2.4 U.S. gal
Hydraulic Tank	50 L	13.2 U.S. gal	58.7 L	15.5 U.S. gal	58.7 L	15.5 U.S. gal
Sprinkler Water	800 L	211 U.S. gal	1100 L	291 U.S. gal	1100 L	291 U.S. gal

<sup>1</sup>With ROPS/FOPS.

<sup>2</sup>Numbers reflect 5 Amplitude vibratory system. Other vibratory system options available.

Specifications  
 ● Double Drum and Combi

Vibratory Compactors



MODEL	CB64		CD54	
Gross Power	102 kW	137 hp	74.5 kW	99.5 hp
Rated Engine RPM	2200		2200	
No. Cylinders	4		4	
Displacement	4.4 L	269 in <sup>3</sup>	4.4 L	269 in <sup>3</sup>
Engine Model	C4.4 with ACERT Technology		3054C DIT	
Speeds	2 forward/2 reverse		Variable	
Max. Speed (For./Rev.)	13 km/h	8 mph	9 km/h	5.5 mph
Working Speed	0-13 km/h	0-8 mph	0-9 km/h	0-5.5 mph
Operating Weight <sup>1</sup>	12 980 kg	28,616 lb	9500 kg	20,944 lb
Shipping Weight <sup>1</sup>	12 901 kg	28,441 lb	—	—
Drive	Hydraulic		Hydraulic	
Steering:				
Inside Radius	3940 mm	12'11"	2800 mm	110"
Outside Radius	6070 mm	19'11"	4500 mm	177"
Steering Angle	±40°		25°	
Vibratory System:				
Ecc. Weight Drive	Hydraulic		Hydraulic	
Frequency	42 Hz	2520 vpm	53 Hz	3180 vpm
Amplitude <sup>2</sup> :				
High Amplitude	1.03 mm	0.041"	0.62 mm	0.024"
Low Amplitude	—	—	0.34 mm	0.013"
Centrifugal Force:				
High Amplitude	138.2 kN	31,100 lb	84 kN	18,900 lb
Low Amplitude	82.6 kN	18,570 lb	74.5 kN	16,762 lb
General Dimensions:				
Overall Width	2335 mm	7'8"	1873 mm	74"
Drum Width	2130 mm	7'0"	1700 mm	67"
Drum Diameter	1300 mm	4'3"	1200 mm	47"
Overall Height (ROPS)	3050 mm	10'1"	3042 mm	120"
Wheelbase	3640 mm	11'11"	3070 mm	121"
Overall Length	4934 mm	16'2"	4270 mm	168"
Curb Clearance	868 mm	34.2"	777 mm	30.5"
Ground Clearance	217 mm	8.5"	372 mm	14.5"
Service Refill Capacities:				
Fuel Tank	191 L	50 U.S. gal	160 L	42.3 U.S. gal
Crankcase	9 L	2.4 U.S. gal	9 L	2.4 U.S. gal
Hydraulic Tank	58.7 L	15.5 U.S. gal	49 L	12.9 U.S. gal
Sprinkler Water	1100 L	291 U.S. gal	750 L	198 U.S. gal

<sup>1</sup>With ROPS/FOPS.

<sup>2</sup>Numbers reflect 5 Amplitude vibratory system. Other vibratory system options available.



**PS150C<sup>1</sup>**

**PS360C<sup>3</sup>**

<b>MODEL</b>	<b>PS150C<sup>1</sup></b>		<b>PS360C<sup>3</sup></b>	
Gross Power	75 kW	100 hp	98 kW	130 hp
Rated Engine RPM	2200		2200	
No. Cylinders	4		4	
Displacement	4.4 L	269 in <sup>3</sup>	4.4 L	269 in <sup>3</sup>
Engine Model	3054C		3054C ATAAC	
Speeds	2 forward/2 reverse		2 forward/2 reverse	
Max. Speed (For./Rev.)	25.6 km/h	15.9 mph	18 km/h	11 mph
Working Speed	11 km/h	6.8 mph	8 km/h	5 mph
Wheel Configuration	5 front/4 rear		3 front/4 rear	
Tires	8.50/90 × 15–6 ply		14/70 × 20–20 ply	
Operating Weight Empty (No ballast) <sup>2</sup>	4885 kg	10,775 lb	8580 kg	18,915 lb
Operating Weight Full (Max. ballast) <sup>2</sup>	12 940 kg	28,535 lb	18 500 kg	40,785 lb
Maximum Weight per Wheel	1440 kg	3180 lb	2645 kg	5830 lb
Shipping Weight	4805 kg	10,580 lb	8500 kg	18,740 lb
Drive	Hydraulic		Hydraulic	
Steering:				
Inside Radius	4648 mm	15'3"	3470 mm	11'5"
Outside Radius	6453 mm	21'2"	6700 mm	22'0"
General Dimensions:				
Overall Width	1740 mm	5'8"	2280 mm	7'6"
Rolling Width	1740 mm	5'8"	2280 mm	7'6"
Tire Width	191 mm	7.5"	368 mm	14.5"
Tire Overlap	13 mm	0.5"	58 mm	2.25"
Overall Height (ROPS)	3000 mm	9'10"	3200 mm	10'6"
Wheelbase	3340 mm	10'11"	3650 mm	12'0"
Overall Length	4290 mm	14'1"	4870 mm	16'0"
Ground Clearance	267 mm	10.5"	252 mm	10"
Service Refill Capacities:				
Fuel Tank	173 L	45.6 U.S. gal	200 L	52 U.S. gal
Crankcase	7.3 L	1.9 U.S. gal	7.3 L	1.9 U.S. gal
Hydraulic Fluid	54.9 L	14.5 U.S. gal	90 L	23.7 U.S. gal
Sprinkler Water	394 L	104 U.S. gal	394 L	104 U.S. gal

<sup>1</sup>11-wheel configuration available.

<sup>2</sup>With ROPS.

<sup>3</sup>Combined ballast available for an operating weight of 25 022 kg (55,115 lb) for PS360C.

**Pneumatic Tires — Bias Ply and Radial**

Model	Tire Size	Ply Rating	Tire Inflation Pressure			
			Minimum Pressure		Maximum Pressure	
			kPa	psi	kPa	psi
PS150C	8.5 × 15	6	275	40	344	50
	7.5 × 15	12	344	50	757	110
	7.5 × 15	14	344	50	862	125
	7.5R15	Radial	296	43	480	70
PS360C	14/70 × 20	20	241	35	757	110

**Ballast Configurations**

Model	Load	Ballast Configuration					
		Empty	Water Only	Steel Only	Wet Sand Only	Steel and Water	Steel and Wet Sand
PS150C	Wheel Load	545 kg <b>1200 lb</b>	970 kg <b>2145 lb</b>	*	1440 kg <b>3180 lb</b>	*	*
	Machine Weight	4885 kg <b>10,775 lb</b>	8710 kg <b>19,205 lb</b>	*	12 940 kg <b>28,535 lb</b>	*	*
PS150C (11-wheel)	Wheel Load	450 kg <b>993 lb</b>	798 kg <b>1760 lb</b>	*	1183 kg <b>2608 lb</b>	*	*
	Machine Weight	4955 kg <b>10,925 lb</b>	8780 kg <b>19,355 lb</b>	*	13 010 kg <b>28,685 lb</b>	*	*
PS150C (Heavy Weight Option)	Wheel Load	457 kg <b>1008 lb</b>	805 kg <b>1775 lb</b>	*	1189 kg <b>2621 lb</b>	*	*
	Machine Weight	5025 kg <b>11,078 lb</b>	8850 kg <b>19,511 lb</b>	*	13 080 kg <b>28,836 lb</b>	*	*
PS360C	Wheel Load	1215 kg <b>2675 lb</b>	1930 kg <b>4250 lb</b>	2285 kg <b>5040 lb</b>	2645 kg <b>5830 lb</b>	2855 kg <b>6300 lb</b>	3570 kg <b>7870 lb</b>
	Machine Weight	8500 kg <b>18,740 lb</b>	13 500 kg <b>29,760 lb</b>	15 995 kg <b>35,265 lb</b>	18 500 kg <b>40,785 lb</b>	20 000 kg <b>44,090 lb</b>	25 000 kg <b>55,115 lb</b>

\*Configuration not available.



**Maximum Ground Pressures**

Model	Ply Rating	Empty	Water Only	Steel Only	Wet Sand Only	Steel and Water	Steel and Wet Sand
PS150C	6	469 kPa <b>68 psi</b>	689 kPa <b>100 psi</b>	*	655 kPa <b>95 psi</b>	*	*
	12	469 kPa <b>68 psi</b>	724 kPa <b>105 psi</b>	*	758 kPa <b>110 psi</b>	*	*
	14	469 kPa <b>68 psi</b>	1041 kPa <b>151 psi</b>	*	972 kPa <b>141 psi</b>	*	*
PS360C	12	655 kPa <b>95 psi</b>	620 kPa <b>90 psi</b>	676 kPa <b>98 psi</b>	662 kPa <b>96 psi</b>	710 kPa <b>103 psi</b>	703 kPa <b>102 psi</b>
	20	896 kPa <b>130 psi</b>	862 kPa <b>125 psi</b>	965 kPa <b>140 psi</b>	917 kPa <b>133 psi</b>	979 kPa <b>142 psi</b>	931 kPa <b>135 psi</b>

\*Configuration not available.  
\*\*Data not available.

**NOTES:**

1. Each tire type has a unique pressure distribution which varies with both tire inflation pressure and wheel load. The distribution of pressure along both transverse and longitudinal profiles is rarely uniform.
2. The measurements in this table represent the peak pressures measured in a transverse profile at each of the ballast conditions at maximum tire inflation pressure.
3. For most applications, it can be assumed that normal operation of the pneumatic compactor will result in the ground being subjected to pressures near the maximum during at least one machine pass.

The tables in this section give production estimates for the following assumed conditions:

Nominal machine travel speed: 6.4 km/h (4.0 mph)

Overlap of rolling width: 15.2 cm (6.0 inches)

Table values give **representative** production rates for three common construction conditions: trenches, roads, and wide areas (> 15 m, or 50 ft).

Model	Drum Width		Lift Thickness		Passes Required	Production Estimates			
	cm	in	cm	in			3.7 m (12 ft) Trench	9.15 m (30 ft) Road Base	Wide Areas
CS323C	127	50	10.2	4	6	m <sup>3</sup> /hr yds <sup>3</sup> /hr	80 104	111 145	122 159
CS423E, CS433E, CS44	167.6	66	10.2	4	4	m <sup>3</sup> /hr yds <sup>3</sup> /hr	159 209	249 326	249 326
CS533E, CS54, CS56	213.4	84	15.2	6	6	m <sup>3</sup> /hr yds <sup>3</sup> /hr	239 313	299 391	324 424
CS64	213.4	84	15.2	6	5	m <sup>3</sup> /hr yds <sup>3</sup> /hr	— —	373 489	405 530
CS74	213.4	84	15.2	6	4	m <sup>3</sup> /hr yds <sup>3</sup> /hr	— —	448 587	486 636
CS76	213.4	84	15.2	12	6	m <sup>3</sup> /hr yds <sup>3</sup> /hr	— —	598 782	648 848
CS76 XT	213.4	84	15.2	12	4	m <sup>3</sup> /hr yds <sup>3</sup> /hr	— —	896 1174	972 1272
CP323C	127	50	15.2	6	6	m <sup>3</sup> /hr yds <sup>3</sup> /hr	120 156	133 174	183 239
CP433E, CP44	167.6	66	15.2	6	6	m <sup>3</sup> /hr yds <sup>3</sup> /hr	159 209	199 261	249 326
CP533E, CP54, CP56	213.4	84	30.5	12	6	m <sup>3</sup> /hr yds <sup>3</sup> /hr	478 626	478 626	647 847
CP76	213.4	84	30.5	12	6	m <sup>3</sup> /hr yds <sup>3</sup> /hr	— —	598 782	648 848

Travel Speed Efficiency

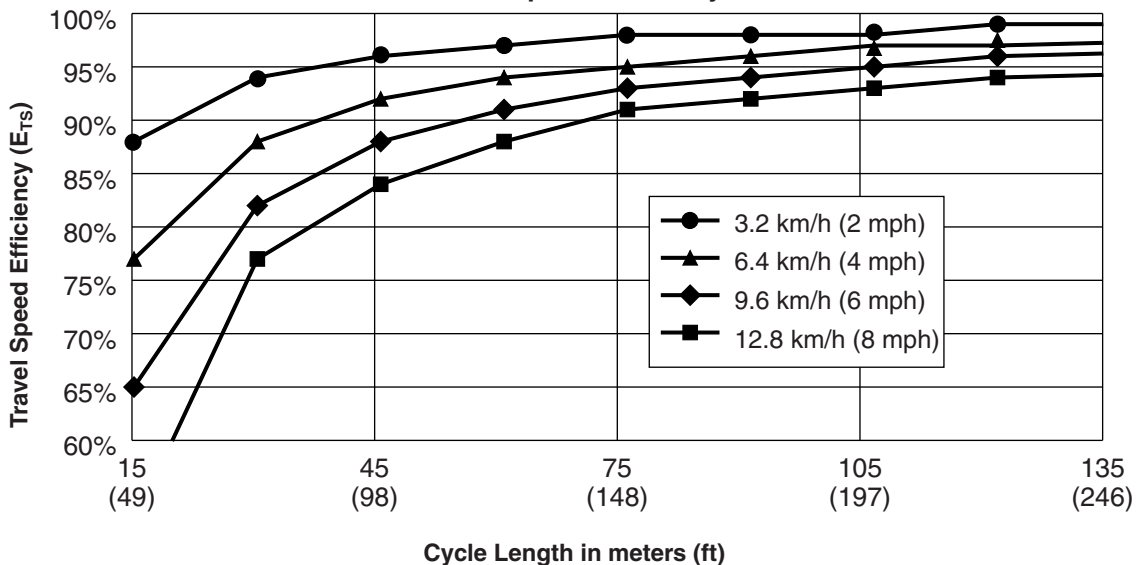

**Adjusting the Production Estimate**

If the assumed conditions are not close to the actual construction conditions, the production estimates should be corrected. The production estimate from the table can be adjusted for 'actual' construction conditions by applying adjustment factors:

$$Q \text{ (actual)} = Q \text{ (assumed)} \times F_s \times F_t \times F_p$$

Where: Q (actual) = adjusted productivity

Q (assumed) = productivity from table based on assumed conditions

F<sub>s</sub> = adjustment for machine speed

F<sub>t</sub> = adjustment for layer thickness

F<sub>p</sub> = adjustment for no. of passes

The adjustment factors are determined by comparing the 'actual' conditions to the 'assumed' ones:

F<sub>s</sub> = actual speed/assumed speed

F<sub>t</sub> = actual thickness/assumed thickness

F<sub>p</sub> = assumed passes/actual passes

Metric example

*Actual Conditions* — An 9.15-meter (full road width) base aggregate job is being completed with a compacted thickness of 15 cm. A CS44 is being used, operating at 4.0 km/h, and making 6 passes to achieve the desired compaction. The roller is overlapping its passes 6 inches.

For a 9.15-meter road base the table gives a CS44 productivity of 249 m<sup>3</sup>/hr. Since the speed, thickness, and passes are *different* from the assumed conditions, we should adjust this estimate:

	Assumed	Actual
Speed	6.4 km/h	4.0 km/h
Thickness	10.2 cm	15 cm
Passes	4 passes	6 passes

$$F_s = 4.0 \text{ km/h} / 6.4 \text{ km/h} = 0.6$$

$$F_t = 15 \text{ cm} / 10.2 \text{ cm} = 1.5$$

$$F_p = 4 \text{ passes} / 6 \text{ passes} = 0.7$$

The estimated production is adjusted using these factors:

$$Q \text{ (actual)} = 249 \text{ m}^3/\text{hr} \times 0.6 \times 1.7 \times 0.7 = 178 \text{ m}^3/\text{hr} \text{ (233 yds}^3/\text{hr)}$$

English example

*Actual Conditions* — An wide area commercial site development job is being compacted in lifts of 8 inches. A CP56 is being used, operating at 4.0 mph, and making 4 passes to achieve the target density.

First, the table gives a CP56 productivity of 847 yds<sup>3</sup>/hr. Since lift thickness and passes required are *different* from the assumed conditions, we should adjust this estimate:

	Assumed	Actual
Speed	4.0 mph	4.0 mph
Thickness	12 inches	8 inches
Passes	6 passes	4 passes

F<sub>s</sub> = no correction necessary

$$F_t = 8 \text{ inches} / 12 \text{ inches} = 0.7$$

$$F_p = 6 \text{ passes} / 4 \text{ passes} = 1.5$$

The estimated production is adjusted using these factors:

$$Q \text{ (actual)} = 847 \text{ yds}^3/\text{hr} \times 0.7 \times 1.5 = 890 \text{ yds}^3/\text{hr} \text{ (680 m}^3/\text{hr)}$$

**Notes on Productivity:**

- For jobs that are relatively narrow, especially road construction jobs, it is important to understand that certain widths of construction will be more productive than others for a given compactor. A productive construction width will make the most use of each side by side pass required by the compactor in order to cover the width.
- Production estimates should be adjusted further if the length of the compaction cycles are shorter than 75 m (250 ft). Refer to the Travel Speed Efficiency chart to determine efficiency E<sub>TS</sub>. For example, a compactor traveling at 6.4 km/h (4 mph) operating at cycle lengths of 150 ft has an E<sub>TS</sub> of 0.91. Multiply Q (actual) by E<sub>TS</sub>.

The table in this section gives production estimates for the following assumed conditions:

Compacted Layer Thickness	51 mm	2 in
Maximum Vibratory Frequency*	—	
Impacts Spacing	33 impacts/m	10 impacts/ft
Passes per Machine Width	2	
Compacted Material Density	2483 kg/m <sup>3</sup>	155 lb/ft <sup>3</sup>
Overlap of Rolling Width	152 mm	6 in
Overhang at Lane Edge	76 mm	3 in
Efficiency	75%	

\*Maximum vibratory frequency varies by machine, refer to table.

Table values give **representative** production rates for common construction widths. If the actual width falls between two assumed widths, use the higher number to estimate production. Minor adjustments can normally be made in the rolling method to reach this higher production: reduce overlap or overhang, increase speed, or increase the cycle time.

Model	Vibration Frequency	Units	PAVING WIDTH						
			1.8 m 6 ft	2.4 m 8 ft	3.0 m 10 ft	3.7 m 12 ft	4.3 m 14 ft	4.9 m 16 ft	5.5 m 18 ft
CB14	53.3 Hz <b>3200 vpm</b>	Tonnes/hr <b>tons/hr</b>	144.6 <b>159.4</b>	150.0 <b>165.3</b>	153.4 <b>169.1</b>	155.8 <b>171.7</b>	—	—	—
CB14 XW (1000 mm/39")	53.3 Hz <b>3200 vpm</b>	Tonnes/hr <b>tons/hr</b>	144.6 <b>159.4</b>	192.9 <b>212.6</b>	187.5 <b>206.7</b>	184.1 <b>202.9</b>	—	—	—
CB14 XW (900 mm/35" and Full Flush)	53.3 Hz <b>3200 vpm</b>	Tonnes/hr <b>tons/hr</b>	144.6 <b>159.4</b>	150.0 <b>165.3</b>	153.4 <b>169.1</b>	184.1 <b>202.9</b>	—	—	—
CB22	63 Hz <b>3780 vpm</b>	Tonnes/hr <b>tons/hr</b>	170.8 <b>188.3</b>	227.8 <b>251.1</b>	221.4 <b>244.1</b>	217.5 <b>239.7</b>	214.6 <b>236.6</b>	245.3 <b>270.4</b>	239.2 <b>263.7</b>
CB24 and CC24	63 Hz <b>3780 vpm</b>	Tonnes/hr <b>tons/hr</b>	239.2 <b>263.7</b>	227.8 <b>251.1</b>	284.8 <b>313.9</b>	265.8 <b>293.0</b>	253.6 <b>279.6</b>	289.9 <b>319.6</b>	276.0 <b>304.2</b>
CB32	63 Hz <b>3780 vpm</b>	Tonnes/hr <b>tons/hr</b>	239.2 <b>263.7</b>	227.8 <b>251.1</b>	284.8 <b>313.9</b>	265.8 <b>293.0</b>	310.1 <b>341.8</b>	289.9 <b>319.6</b>	326.1 <b>359.5</b>
CB34 and CC34	69 Hz <b>4140 vpm</b>	Tonnes/hr <b>tons/hr</b>	262.0 <b>288.8</b>	249.5 <b>275.0</b>	311.9 <b>343.8</b>	291.1 <b>320.9</b>	339.6 <b>374.3</b>	317.5 <b>350.0</b>	357.2 <b>393.8</b>
CB34 XW	53 Hz <b>3180 vpm</b>	Tonnes/hr <b>tons/hr</b>	201.2 <b>221.8</b>	268.3 <b>295.7</b>	239.6 <b>264.1</b>	287.5 <b>316.9</b>	260.8 <b>287.5</b>	298.1 <b>328.6</b>	274.4 <b>302.5</b>
CB434D	70 Hz <b>4200 vpm</b>	Tonnes/hr <b>tons/hr</b>	265.8 <b>293.0</b>	354.3 <b>390.6</b>	316.4 <b>348.8</b>	379.7 <b>418.5</b>	344.5 <b>379.8</b>	393.7 <b>434.0</b>	362.4 <b>399.5</b>
CB434D XW	70 Hz <b>4200 vpm</b>	Tonnes/hr <b>tons/hr</b>	265.8 <b>293.0</b>	354.3 <b>390.6</b>	443.0 <b>488.3</b>	379.7 <b>418.5</b>	442.9 <b>488.3</b>	393.7 <b>434.0</b>	442.9 <b>488.3</b>
CB54	63.3 Hz <b>3800 vpm</b>	Tonnes/hr <b>tons/hr</b>	240.5 <b>265.1</b>	320.6 <b>353.4</b>	400.8 <b>441.8</b>	343.5 <b>378.6</b>	400.8 <b>441.8</b>	356.3 <b>392.7</b>	400.8 <b>441.8</b>
CB54 XW	63.3 Hz <b>3800 vpm</b>	Tonnes/hr <b>tons/hr</b>	400.8 <b>441.8</b>	320.6 <b>353.4</b>	400.8 <b>441.8</b>	480.9 <b>530.1</b>	400.8 <b>441.8</b>	458.0 <b>504.9</b>	515.3 <b>568.0</b>
CB64	63.3 Hz <b>3800 vpm</b>	Tonnes/hr <b>tons/hr</b>	400.8 <b>441.8</b>	320.6 <b>353.4</b>	400.8 <b>441.8</b>	480.9 <b>530.1</b>	400.8 <b>441.8</b>	458.0 <b>504.9</b>	515.3 <b>568.0</b>
CD54	63.3 Hz <b>3800 vpm</b>	Tonnes/hr <b>tons/hr</b>	201.2 <b>221.8</b>	191.6 <b>211.2</b>	239.6 <b>264.1</b>	223.6 <b>246.5</b>	260.8 <b>287.5</b>	243.9 <b>268.9</b>	274.4 <b>302.5</b>

### Example

*Actual Conditions* — A 3.7 m (12 ft) lane is being paved with a compacted asphalt thickness of 10 cm (4 in). A CB54 is operating with a frequency of 42 Hz (2520 vpm) and 46 impacts per meter (14 impacts per ft) and making 4 passes to achieve target density. The roller is overlapping its passes 15 cm (6 in) and is overhanging the edges by 7.5 cm (3 in).

First, the table gives a CB54 productivity of 343 Tonnes/hr (378.6 tons/hr) for a 3.7 m (12 ft) paving width. Since the actual vibratory speed, thickness, impact spacing and passes are different from the assumed conditions, the estimate should be adjusted.

	Assumed		Actual	
<b>Vibratory Speed</b>	63.3 Hz	<b>3800 vpm</b>	42 Hz	<b>2520 vpm</b>
<b>Impact Spacing</b>	33 impacts/m	<b>10 impacts/ft</b>	46 impacts/m	<b>14 impacts/ft</b>
<b>Thickness</b>	5 cm	<b>2 in</b>	10 cm	<b>4 in</b>
<b>Passes</b>		<b>2</b>		<b>4</b>

$$F_s = 42 \text{ Hz (2520 vpm)} / 63.3 \text{ Hz (3800 vpm)} = 0.66$$

$$F_i = 33 \text{ impacts/m (10 impacts/ft)} / 46 \text{ impacts/m (14 impacts/ft)} = 0.71$$

$$F_t = 10 \text{ cm (4 in)} / 5 \text{ cm (2 in)} = 2.0$$

$$F_p = 2 \text{ passes} / 4 \text{ passes} = 0.5$$

The actual, or adjusted, production estimate can then be determined from the following:

$$Q \text{ (actual)} = 343 \text{ Tonnes/hr (378.6 tons/hr)} \\ \times 0.66 \times 0.71 \times 2 \times 0.5 = \\ 161 \text{ Tonnes/hr (177.4 tons/hr)}$$

### Notes on Productivity:

- Higher speed usually results in lower density achieved per pass.
- Productivity on uphill slopes may be reduced.
- Tabulated production estimates assume that 1 pass is used for re-positioning the machine at the beginning of the next run.

The tables in this section give production estimates for the following assumed conditions:

	Hot Mix Asphalt		Soil and Aggregate		Cold In-Place Recycled Asphalt	
Compacted Layer Thickness	51 mm	<b>2 in</b>	152 mm	<b>6 in</b>	203 mm	<b>8 in</b>
Maximum Propelling Speed	8 km/h	<b>5 mph</b>	8 km/h	<b>5 mph</b>	4.8 km/h	<b>3 mph</b>
Passes per Machine Width	<b>4</b>		<b>4</b>		<b>6</b>	
Compacted Material Density	2486 kg/cm <sup>3</sup>	<b>155 lb/ft<sup>3</sup></b>	2085 kg/cm <sup>3</sup>	<b>130 lb/ft<sup>3</sup></b>	2246 kg/cm <sup>3</sup>	<b>140 lb/ft<sup>3</sup></b>
Overlap of Rolling Width	152 mm	<b>6 in</b>	152 mm	<b>6 in</b>	152 mm	<b>6 in</b>
Overhang at Lane Edge	76 mm	<b>3 in</b>	76 mm	<b>3 in</b>	76 mm	<b>3 in</b>
Cycle Time (2 passes)	<b>120 seconds</b>		<b>120 seconds</b>		<b>120 seconds</b>	

Table values give **representative** production rates for common construction widths. If the actual width falls between two assumed widths, use the higher number to estimate production. Minor adjustments can normally be made in the rolling method to reach this higher production: reduce overlap or overhang, increase speed, or increase the cycle time.

<b>Hot Mix Asphalt</b>		<b>PAVING WIDTH</b>						
		1.8 m <b>6 ft</b>	2.4 m <b>8 ft</b>	3.0 m <b>10 ft</b>	3.7 m <b>12 ft</b>	4.3 m <b>14 ft</b>	4.9 m <b>16 ft</b>	5.5 m <b>18 ft</b>
<b>Model</b>	<b>Units</b>							
PS150C	Tonnes/hr <b>tons/hr</b>	195.2 <b>215.1</b>	260.2 <b>286.8</b>	325.3 <b>358.6</b>	270.2 <b>297.9</b>	315.3 <b>347.5</b>	275.5 <b>303.7</b>	310.0 <b>341.7</b>
PS360C	Tonnes/hr <b>tons/hr</b>	351.3 <b>387.2</b>	260.2 <b>286.8</b>	325.3 <b>358.6</b>	390.3 <b>430.3</b>	455.4 <b>502.0</b>	360.3 <b>397.2</b>	405.3 <b>446.8</b>

<b>Soil and Aggregate</b>								
PS150C	Tonnes/hr <b>tons/hr</b>	490.1 <b>540.2</b>	653.4 <b>720.3</b>	816.8 <b>900.4</b>	678.6 <b>748.0</b>	791.7 <b>872.7</b>	691.9 <b>762.7</b>	778.4 <b>858.0</b>
PS360C	Tonnes/hr <b>tons/hr</b>	882.2 <b>972.4</b>	653.4 <b>720.3</b>	816.8 <b>900.4</b>	980.2 <b>1080.4</b>	1143.5 <b>1260.5</b>	904.8 <b>997.3</b>	1017.9 <b>1122.0</b>

<b>Cold In-Place Recycled Asphalt</b>								
PS150C	Tonnes/hr <b>tons/hr</b>	288.0 <b>317.5</b>	384.0 <b>423.3</b>	480.0 <b>529.2</b>	394.1 <b>434.5</b>	459.8 <b>506.9</b>	399.4 <b>440.3</b>	449.3 <b>495.3</b>
PS360C	Tonnes/hr <b>tons/hr</b>	534.9 <b>589.6</b>	384.0 <b>423.3</b>	480.0 <b>529.2</b>	576.1 <b>635.0</b>	672.1 <b>740.8</b>	525.5 <b>579.3</b>	591.2 <b>651.7</b>

Example

*Actual Conditions* — A 7.3 m (23'11") (full road width) base aggregate job is being completed with a compacted thickness of 200 mm (8 in). A PS150C is being used, operating at 6.5 km/h (4 mph), and making 6 passes achieve the desired compaction. The roller is overlapping its passes 152 mm (6 in).

First, the table does not show production for 7.3 m (23'11") so use the greatest width on the table: 5.5 m (18'1"). The table gives a PS150C productivity of 778.4 Tonnes/hr (858.0 tons/hr) for this paving width. We can expect that the actual productivity for 7.3 m (23'11") will be slightly higher than that. Since the speed, thickness, and passes are *different* from the assumed conditions, we should adjust this estimate:

	Assumed		Actual	
<b>Speed</b>	8 km/h	<b>5 mph</b>	6.5 km/h	<b>4 mph</b>
<b>Thickness</b>	152 mm	<b>6 in</b>	200 mm	<b>8 in</b>
<b>Passes</b>	<b>4</b>		<b>6</b>	

$$F_s = 6.5 \text{ km/h} / 8 \text{ km/h} (4 \text{ mph} / 5 \text{ mph}) = 0.8$$

$$F_t = 200 \text{ mm} / 152 \text{ mm} (8 \text{ in} / 6 \text{ in}) = 1.3$$

$$F_p = 4 \text{ passes} / 6 \text{ passes} = 0.7$$

The estimated production is adjusted using these factors:

$$Q (\text{actual}) = 778.4 \text{ Tonnes/hr} (858.0 \text{ tons/hr}) \times 0.8 \times 1.3 \times 0.7 = 567 \text{ Tonnes/hr} (625 \text{ ton/hr})$$

**Notes on Productivity:**

- Ballast weight and tire pressure can significantly affect performance of a pneumatic tire compactor. Refer to machine specifications to choose the best configuration.
- Productivity on uphill grades and very thick layers (>127 mm, or 5 in) may be reduced due to a necessary reduction in speed.
- The 11-tire configuration for the PS150C is designed only for chip-and-seal applications. It is not recommended in other applications.

# UNDERGROUND MINING EQUIPMENT

## Loaders and Haulers for Hard Rock Mining

### CONTENTS

Features .....	16-1
Load-Haul-Dumps (LHDs):	
Specifications .....	16-2
Dimensions and Capacities .....	16-4
Bucket Selection .....	16-5
Turning Dimensions .....	16-5
Curves:	
R1300G Rimpull-Speed-Gradeability .....	16-6
R1600G Rimpull-Speed-Gradeability .....	16-7
R1700G Rimpull-Speed-Gradeability .....	16-8
R2900G Rimpull-Speed-Gradeability .....	16-9
R2900G XTRA Rimpull-Speed-Gradeability .....	16-10
Trucks:	
Articulated Specifications .....	16-11
Dimensions and Capacities .....	16-12
Curves:	
AD30 Rimpull-Speed-Gradeability .....	16-13
AD45B Rimpull-Speed-Gradeability .....	16-14
AD55B Rimpull-Speed-Gradeability .....	16-15
LHD and Truck Systems .....	16-16

### Features, all models:

- Rugged design for underground application.
- Engineered for productivity, reliability, safety and machine rebuildability.
- Extensive use of steel castings and forgings.
- Caterpillar heavy duty diesel engines and power trains.
- Computerized machine function monitoring.
- Four wheel enclosed wet disc brakes.
- Remote control options on loaders.
- Payload control system option on loaders.
- Ride control system optional on loaders.
- Fully enclosed air conditioned operator stations available.
- Operator Stations are ROPS/FOPS certified.

### Product Line:

- Five models of Load-Haul-Dump (LHD) machines, with rated bucket payloads ranging from 6800 kg (14,991 lb) to 20 000 kg (44,100 lb).
- Three models of articulated dump trucks, with payload capacities of 30 000 kg (66,140 lb) to 55 000 kg (121,247 lb).
- Three models of articulated ejector trucks, with payload capacities of 27 000 kg (59,500 lb) to 50 000 kg (110,231 lb).





<b>MODEL</b>	<b>R1300G</b>		<b>R1600G</b>	
Engine Model	<b>3306B DITA</b>		<b>3176C EUI ATAAC</b>	
Engine Power — Gross	123 kW	<b>165 hp</b>	186/201 kW+	<b>249/270 hp+</b>
Engine Power — Net	105 kW	<b>141 hp</b>	165/180 kW+	<b>221/221 hp+</b>
Tire Size	<b>17.5 × R25 VSMS L-5S</b>		<b>18 × R25 VSMS L-5S</b>	
Nominal Payload Capacity — Trimming	6800 kg	<b>14,991 lb</b>	10 200 kg	<b>22,487 lb</b>
Nominal Payload Capacity — Truck Loading	6800 kg	<b>14,991 lb</b>	10 200 kg	<b>22,487 lb</b>
Gross Machine Operating Weight	27 750 kg	<b>61,178 lb</b>	40 000 kg	<b>88,185 lb</b>
Bucket Size — Minimum	2.4 m <sup>3</sup>	<b>3.1 yd<sup>3</sup></b>	4.2 m <sup>3</sup>	<b>5.5 yd<sup>3</sup></b>
Bucket Size — Maximum	3.4 m <sup>3</sup>	<b>4.4 yd<sup>3</sup></b>	5.9 m <sup>3</sup>	<b>7.7 yd<sup>3</sup></b>
Length — Overall Digging	9107 mm	<b>358.5"</b>	10 107 mm	<b>397.9"</b>
— Overall Trimming	8714 mm	<b>343.1"</b>	9711 mm	<b>382.3"</b>
— Wheel Base	3050 mm	<b>120"</b>	3536 mm	<b>139.2"</b>
Width — Overall with Bucket	2318 mm	<b>91.3"</b>	2264 mm	<b>104.9"</b>
— Overall without Bucket	2071 mm	<b>81.5"</b>	2564 mm	<b>100.9"</b>
— Over Tires	1900 mm	<b>74.8"</b>	2400 mm	<b>94.5"</b>
Height — Overall Bucket Raised	4302 mm	<b>169.4"</b>	5168 mm	<b>203.5"</b>
— Maximum Bucket Pin	2918 mm	<b>114.9"</b>	3572 mm	<b>147.7"</b>
— Top of ROPS	2120 mm	<b>83.5"</b>	2400 mm	<b>94.5"</b>
— Dump Clearance	1560 mm	<b>61.4"</b>	2207 mm	<b>86.9"</b>
— Ground Clearance	328 mm	<b>12.9"</b>	344 mm	<b>13.5"</b>
Turning Radius — Outer	5741 mm	<b>226"</b>	6638 mm	<b>261.3"</b>
— Inner	2914 mm	<b>115"</b>	3291 mm	<b>129.6"</b>
Angle — Articulation	<b>±42.5°</b>		<b>±42.5°</b>	
— Rear Axle Oscillation	<b>±10.0°</b>		<b>±10.0°</b>	
— Maximum Bucket Dump	<b>43°</b>		<b>45°</b>	
Hydraulic Cycle Time:				
Raise	<b>5.0 Sec.</b>		<b>7.6 Sec.</b>	
Dump	<b>2.0 Sec.</b>		<b>1.6 Sec.</b>	
Lower	<b>2.3 Sec.</b>		<b>2.0 Sec.</b>	
Total	<b>9.3 Sec.</b>		<b>11.2 Sec.</b>	
Travel Speeds:	<b>km/h</b>	<b>mph</b>	<b>km/h</b>	<b>mph</b>
Forward — 1st	5.0	<b>3.1</b>	5.0	<b>3.1</b>
— 2nd	9.0	<b>5.6</b>	8.7	<b>5.4</b>
— 3rd	17.0	<b>10.6</b>	15.2	<b>9.5</b>
— 4th	24.0	<b>14.9</b>	22.1	<b>13.7</b>
Reverse — 1st	5.0	<b>3.1</b>	5.7	<b>3.5</b>
— 2nd	8.0	<b>5.0</b>	9.9	<b>6.1</b>
— 3rd	15.0	<b>9.3</b>	17.2	<b>10.7</b>
— 4th	23.0	<b>14.3</b>	23.8	<b>14.8</b>
Tilt Break Out Force SAE	12 020 kg	<b>26,500 lb</b>	19 280 kg	<b>42,505 lb</b>
Lift Break Out Force SAE	11 750 kg	<b>25,909 lb</b>	19 270 kg	<b>42,483 lb</b>
Static Tipping Load — Straight* (\$) )	20 575 kg	<b>45,360 lb</b>	28 100 kg	<b>61,950 lb</b>
— Full Turn* (\$) )	17 870 kg	<b>39,397 lb</b>	23 500 kg	<b>51,809 lb</b>
Refill Capacity:				
Fuel	295 L	<b>78 U.S. gal</b>	400/730 L++	<b>106/193 U.S. gal++</b>
Engine Crankcase with Filter	25 L	<b>6.6 U.S. gal</b>	36 L	<b>9.5 U.S. gal</b>
Transmission	45 L	<b>11.9 U.S. gal</b>	36 L	<b>9.5 U.S. gal</b>
Hydraulic Tank	88 L	<b>23.2 U.S. gal</b>	125 L	<b>33 U.S. gal</b>
Cooling System	67 L	<b>17.7 U.S. gal</b>	53 L	<b>14 U.S. gal</b>

\*Static tipping loads shown are for unoptioned standard machines with standard bucket and tires, full fuel tank and operator at 75 kg (165 lb), as per SAE J732 JUN92 5.2.

+Dual Horsepower — Higher horsepower for different gears.

++Standard fuel tank/With secondary fuel tank.



MODEL	R1700G		R2900G		R2900G XTRA	
Engine Model	C11 ACERT ATAAC		C15 ACERT ATAAC		C15 ACERT ATAAC	
Engine Power — Gross	241/262 kW+	<b>323/353 hp+</b>	321/333 kW+	<b>430/477 hp+</b>	321/333 kW+	<b>430/477 hp+</b>
Engine Power — Net	219/241 kW+	<b>294/323 hp+</b>	296/308 kW+	<b>397/413 hp+</b>	296/308 kW+	<b>397/413 hp+</b>
Tire Size	<b>26.5 × R25 VSMS L5S</b>		<b>29.5 × 29 2★VSMS</b>		<b>35/65 R33★*VSDL</b>	
Nominal Payload Capacity:						
— Trimming	14 000 kg	<b>30,865 lb</b>	17 200 kg	<b>37,920 lb</b>	20 000 kg	<b>44,092 lb</b>
— Truck Loading	12 500 kg	<b>27,558 lb</b>	17 200 kg	<b>37,920 lb</b>	17 200 kg	<b>37,920 lb</b>
Gross Machine Operating Weight	52 500 kg	<b>115,745 lb</b>	67 409 kg	<b>148,613 lb</b>	75 575 kg	<b>166,614 lb</b>
Bucket Size — Minimum	4.6 m <sup>3</sup>	<b>6.0 yd<sup>3</sup></b>	6.3 m <sup>3</sup>	<b>8.2 yd<sup>3</sup></b>	8.9 m <sup>3</sup>	<b>11.6 yd<sup>3</sup></b>
Bucket Size — Maximum	8.8 m <sup>3</sup>	<b>11.5 yd<sup>3</sup></b>	8.9 m <sup>3</sup>	<b>11.6 yd<sup>3</sup></b>	11.6 m <sup>3</sup>	<b>15.2 yd<sup>3</sup></b>
Length — Overall Digging	10 973 mm	<b>432.0"</b>	11 302 mm	<b>445.0"</b>	11 524 mm	<b>453.7"</b>
— Overall Trimming	10 588 mm	<b>416.9"</b>	10 949 mm	<b>431.1"</b>	11 083 mm	<b>436.4"</b>
— Wheel Base	3680 mm	<b>144.9"</b>	3780 mm	<b>148.8"</b>	3780 mm	<b>148.8"</b>
Width — Overall with Bucket	2894 mm	<b>113.9"</b>	3176 mm	<b>125.0"</b>	3472 mm	<b>136.7"</b>
— Overall without Bucket	2689 mm	<b>105.8"</b>	3010 mm	<b>118.5"</b>	3200 mm	<b>126.0"</b>
— Over Tires	2650 mm	<b>104.3"</b>	2898 mm	<b>114.1"</b>	3142 mm	<b>123.7"</b>
Height — Overall Bucket Raised	5606 mm	<b>220.7"</b>	6179 mm	<b>243.3"</b>	6235 mm	<b>245.5"</b>
— Maximum Bucket Pin	4104 mm	<b>161.6"</b>	4539 mm	<b>178.7"</b>	4541 mm	<b>178.8"</b>
— Top of ROPS	2557 mm	<b>100.7"</b>	2886 mm	<b>113.6"</b>	2988 mm	<b>117.6"</b>
— Dump Clearance	2477 mm	<b>97.5"</b>	2868 mm	<b>112.9"</b>	2726 mm	<b>107.3"</b>
— Ground Clearance	429 mm	<b>16.9"</b>	465 mm	<b>18.3"</b>	466 mm	<b>18.3"</b>
Turning Radius — Outer	6878 mm	<b>270.8"</b>	7323 mm	<b>288.3"</b>	7511 mm	<b>295.7"</b>
— Inner	3229 mm	<b>127.1"</b>	3383 mm	<b>133.2"</b>	3289 mm	<b>129.5"</b>
Angle — Articulation	<b>±44.0°</b>		<b>±42.5°</b>		<b>±42.5°</b>	
— Rear Axle Oscillation	<b>±8.0°</b>		<b>±8.0°</b>		<b>±8.0°</b>	
— Maximum Bucket Dump	<b>46°</b>		<b>42°</b>		<b>42°</b>	
Hydraulic Cycle Time:						
Raise	<b>6.8 Sec.</b>		<b>9.2 Sec.</b>		<b>9.2 Sec.</b>	
Dump	<b>2.9 Sec.</b>		<b>3.4 Sec.</b>		<b>3.4 Sec.</b>	
Lower	<b>2.4 Sec.</b>		<b>3.1 Sec.</b>		<b>3.1 Sec.</b>	
Total	<b>12.1 Sec.</b>		<b>15.7 Sec.</b>		<b>15.7 Sec.</b>	
Travel Speeds:	<b>km/h</b>	<b>mph</b>	<b>km/h</b>	<b>mph</b>	<b>km/h</b>	<b>mph</b>
Forward — 1st	4.7	<b>2.9</b>	5.0	<b>3.1</b>	5.0	<b>3.1</b>
— 2nd	8.3	<b>5.2</b>	8.8	<b>5.5</b>	8.8	<b>5.5</b>
— 3rd	14.3	<b>8.9</b>	15.2	<b>9.4</b>	15.2	<b>9.4</b>
— 4th	24.1	<b>15.0</b>	25.3	<b>15.7</b>	25.3	<b>15.7</b>
Reverse — 1st	5.4	<b>3.3</b>	6.2	<b>3.8</b>	6.2	<b>3.8</b>
— 2nd	9.4	<b>5.8</b>	10.9	<b>6.8</b>	10.9	<b>6.8</b>
— 3rd	16.4	<b>10.2</b>	18.6	<b>11.6</b>	18.6	<b>11.6</b>
— 4th	25.3	<b>15.7</b>	26.4	<b>16.4</b>	26.4	<b>16.4</b>
Tilt Break Out Force SAE	20 885 kg	<b>46,051 lb</b>	27 346 kg	<b>60,298 lb</b>	27 346 kg	<b>60,298 lb</b>
Lift Break Out Force SAE	10 633 kg	<b>23,446 lb</b>	22 704 kg	<b>50,062 lb</b>	22 704 kg	<b>50,062 lb</b>
Static Tipping Load — Straight* (\$) )	31 781 kg	<b>70,065 lb</b>	39 923 kg	<b>88,015 lb</b>	47 776 kg	<b>105,306 lb</b>
— Full Turn* (\$) )	26 306 kg	<b>57,995 lb</b>	34 069 kg	<b>75,109 lb</b>	40 472 kg	<b>89,225 lb</b>
Refill Capacity:						
Fuel	550/	<b>145/</b>	854/	<b>226/</b>	854/	<b>226/</b>
	1080 L++	<b>185 U.S. gal++</b>	1425 L++	<b>376 U.S. gal++</b>	1425 L++	<b>376 U.S. gal++</b>
Engine Crankcase with Filter	34 L	<b>8.98 U.S. gal</b>	34 L	<b>9.0 U.S. gal</b>	34 L	<b>9.0 U.S. gal</b>
Transmission	47 L	<b>12.4 U.S. gal</b>	62 L	<b>16.4 U.S. gal</b>	62 L	<b>16.4 U.S. gal</b>
Hydraulic Tank	125 L	<b>33 U.S. gal</b>	140 L	<b>37.0 U.S. gal</b>	140 L	<b>37.0 U.S. gal</b>
Cooling System	63 L	<b>16.6 U.S. gal</b>	75 L	<b>19.8 U.S. gal</b>	75 L	<b>19.8 U.S. gal</b>

\*Static tipping loads shown are for unoptioned standard machines with standard bucket and tires, full fuel tank and operator at 75 kg (165 lb), as per SAE J732 JUN92 5.2.

+Dual Horsepower — Higher horsepower for different gears.

++Standard fuel tank/With secondary fuel tank.

Model	R1300G		R1600G		R1700G	
Nominal Payload Capacity:						
— Tramming	6800 kg	<b>14,991 lb</b>	10 200 kg	<b>22,487 lb</b>	14 000 kg	<b>30,865 lb</b>
— Truck Loading	6800 kg	<b>14,991 lb</b>	10 200 kg	<b>22,487 lb</b>	12 500 kg	<b>27,558 lb</b>
Gross Machine Operating Weight	27 750 kg	<b>61,178 lb</b>	40 000 kg	<b>88,185 lb</b>	52 500 kg	<b>115,745 lb</b>
Bucket Capacity — Standard	3.1 m <sup>3</sup>	<b>4.1 yd<sup>3</sup></b>	4.8 m <sup>3</sup>	<b>6.3 yd<sup>3</sup></b>	5.7 m <sup>3</sup>	<b>7.5 yd<sup>3</sup></b>
Overall Width with Bucket	2318 mm	<b>91.3"</b>	2264 mm	<b>104.9"</b>	2894 mm	<b>113.9"</b>
Overall Height — Top of ROPS	2120 mm	<b>83.5"</b>	2400 mm	<b>94.5"</b>	2557 mm	<b>100.7"</b>
Length — Overall Digging	9107 mm	<b>358.5"</b>	10 107 mm	<b>397.9"</b>	10 973 mm	<b>432.0"</b>
— Overall Tramming	8714 mm	<b>343.1"</b>	9711 mm	<b>382.3"</b>	10 588 mm	<b>416.9"</b>
Operating Weight	20 950 kg	<b>46,187 lb</b>	29 800 kg	<b>65,698 lb</b>	38 500 kg	<b>84,878 lb</b>
Loaded Weight	27 750 kg	<b>61,178 lb</b>	40 000 kg	<b>88,185 lb</b>	55 000 kg	<b>121,254 lb</b>
Ground Clearance	328 mm	<b>12.9"</b>	344 mm	<b>13.5"</b>	429 mm	<b>16.9"</b>
Axle Oscillation	<b>± 10.0°</b>		<b>± 10.0°</b>		<b>± 8.0°</b>	

Model	R2900G		R2900G XTRA	
Nominal Payload Capacity:				
— Tramming	17 200 kg	<b>37,920 lb</b>	20 000 kg	<b>44,092 lb</b>
— Truck Loading	17 200 kg	<b>37,920 lb</b>	17 200 kg	<b>37,920 lb</b>
Gross Machine Operating Weight	67 409 kg	<b>148,613 lb</b>	75 575 kg	<b>166,614 lb</b>
Bucket Capacity — Standard	7.2 m <sup>3</sup>	<b>9.4 yd<sup>3</sup></b>	8.9 m <sup>3</sup>	<b>11.6 yd<sup>3</sup></b>
Overall Width with Bucket	3176 mm	<b>125.0"</b>	3472 mm	<b>136.7"</b>
Overall Height — Top of ROPS	2886 mm	<b>113.6"</b>	2988 mm	<b>117.6"</b>
Length — Overall Digging	11 302 mm	<b>445.0"</b>	11 524 mm	<b>453.7"</b>
— Overall Tramming	10 949 mm	<b>431.1"</b>	11 083 mm	<b>436.4"</b>
Operating Weight	50 209 kg	<b>110,692 lb</b>	55 575 kg	<b>122,522 lb</b>
Loaded Weight	70 350 kg	<b>155,095 lb</b>	80 483 kg	<b>177,434 lb</b>
Ground Clearance	465 mm	<b>18.3"</b>	466 mm	<b>18.3"</b>
Axle Oscillation	<b>± 8.0°</b>		<b>± 8.0°</b>	

Model	Bucket Type	SAE Capacity	
		m <sup>3</sup>	yd <sup>3</sup>
<b>R1300G</b>	Standard	2.4	<b>3.1</b>
	Standard	2.8	<b>3.6</b>
	Standard	3.1	<b>4.1</b>
	Standard	3.4	<b>4.5</b>
	Ejector	2.5	<b>3.3</b>
<b>R1600G</b>	Standard	4.2	<b>5.5</b>
	Standard	4.8	<b>6.3</b>
	Standard	5.6	<b>7.3</b>
	Standard	5.9	<b>7.7</b>
	Ejector	4.8	<b>6.3</b>
<b>R1700G</b>	Standard*	4.6	<b>6.0</b>
	Standard*	5.0	<b>6.5</b>
	Standard*	5.7	<b>7.5</b>
	Standard*	6.6	<b>8.6</b>
	Light Materials Ejector	8.8 5.6	<b>11.5 7.3</b>

Model	Bucket Type	SAE Capacity	
		m <sup>3</sup>	yd <sup>3</sup>
<b>R2900G</b>	Standard	6.3	<b>8.2</b>
	Standard*	7.2	<b>9.4</b>
	Standard*	8.3	<b>10.9</b>
	Standard*	8.9	<b>11.6</b>
	Ejector	7.1	<b>9.3</b>
<b>R2900G XTRA</b>	Standard	8.3	<b>10.9</b>
	Standard*	8.9	<b>11.6</b>
	Light Materials	10.5	<b>13.7</b>
	Light Materials	11.6	<b>15.2</b>

\*High Penetration Bucket available.

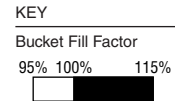
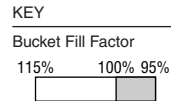
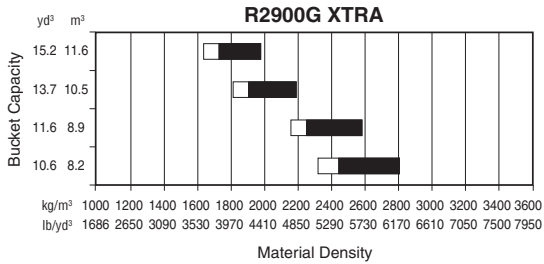
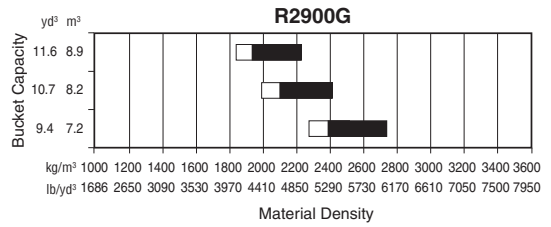
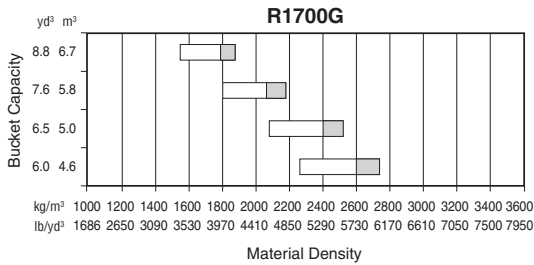
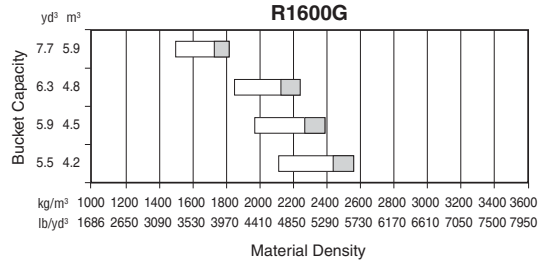
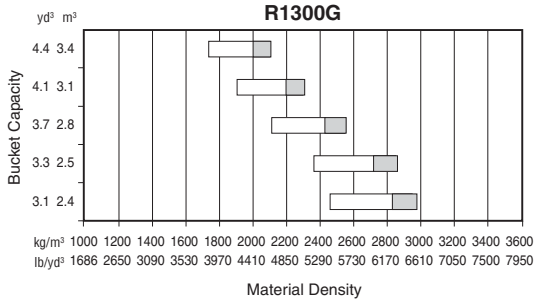

**Turning Dimensions**

Model	R1300G		R1600G		R1700G		R2900G		R2900G XTRA	
Outer Turning Radius	5741 mm	226"	6638 mm	261.3"	6878 mm	270.8"	7323 mm	288.3"	7511 mm	295.7"
Inner Turning Radius	2914 mm	115"	3291 mm	129.6"	3229 mm	127.1"	3383 mm	133.2"	3289 mm	129.5"
Articulation Angle	±42.5°		±42.5°		±44.0°		±42.5°		±42.5°	

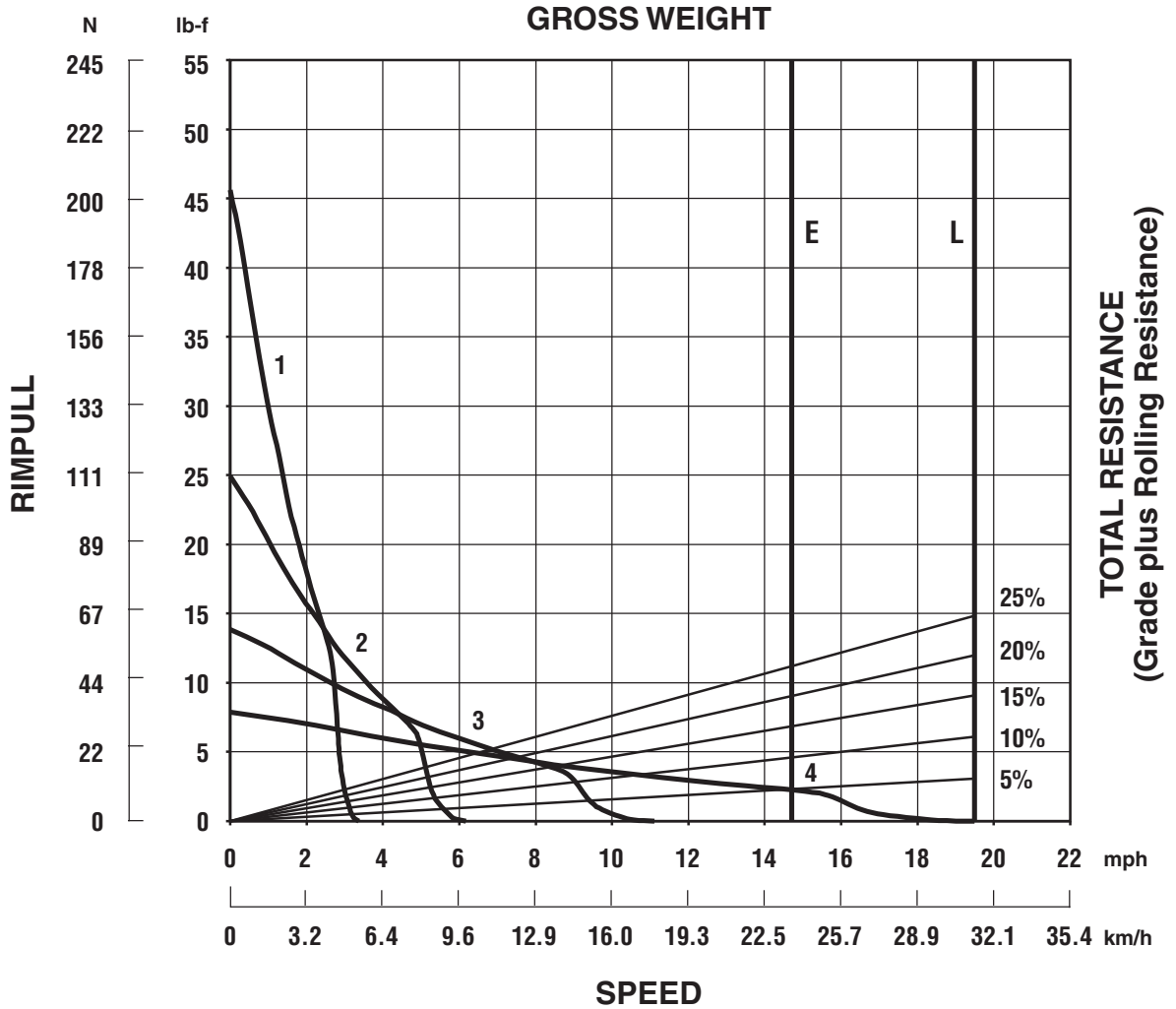

**KEY**

- 1 — 1st Gear
- 2 — 2nd Gear
- 3 — 3rd Gear
- 4 — 4th Gear

**KEY**

- E — Empty 20 950 kg (46,187 lb)
- L — Loaded 27 750 kg (61,178 lb)

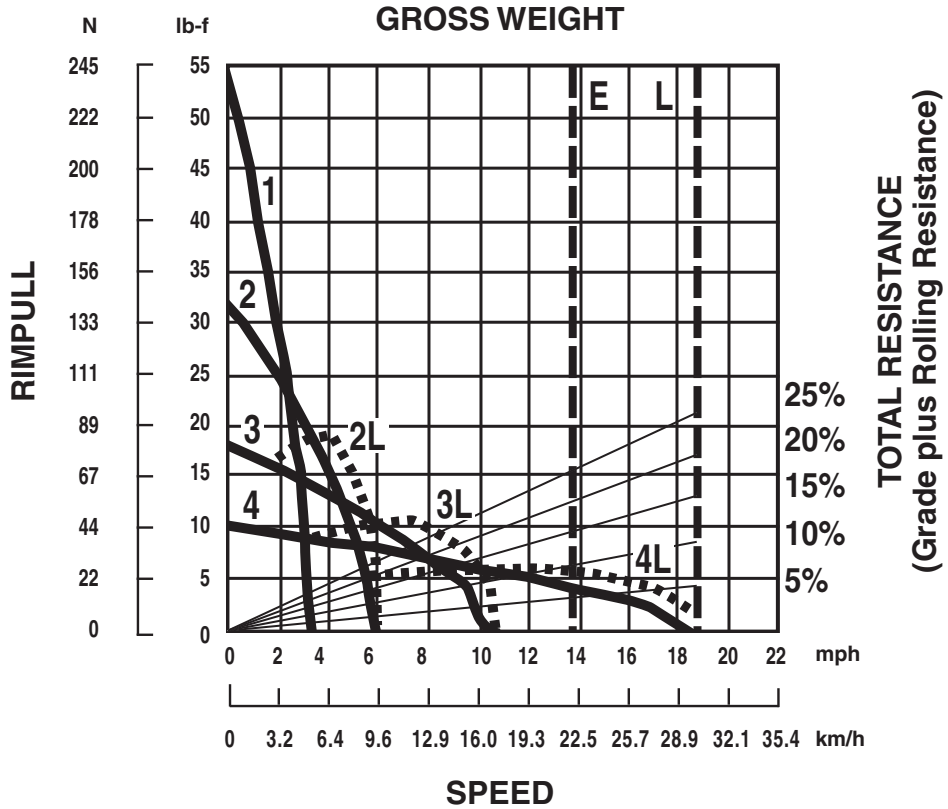

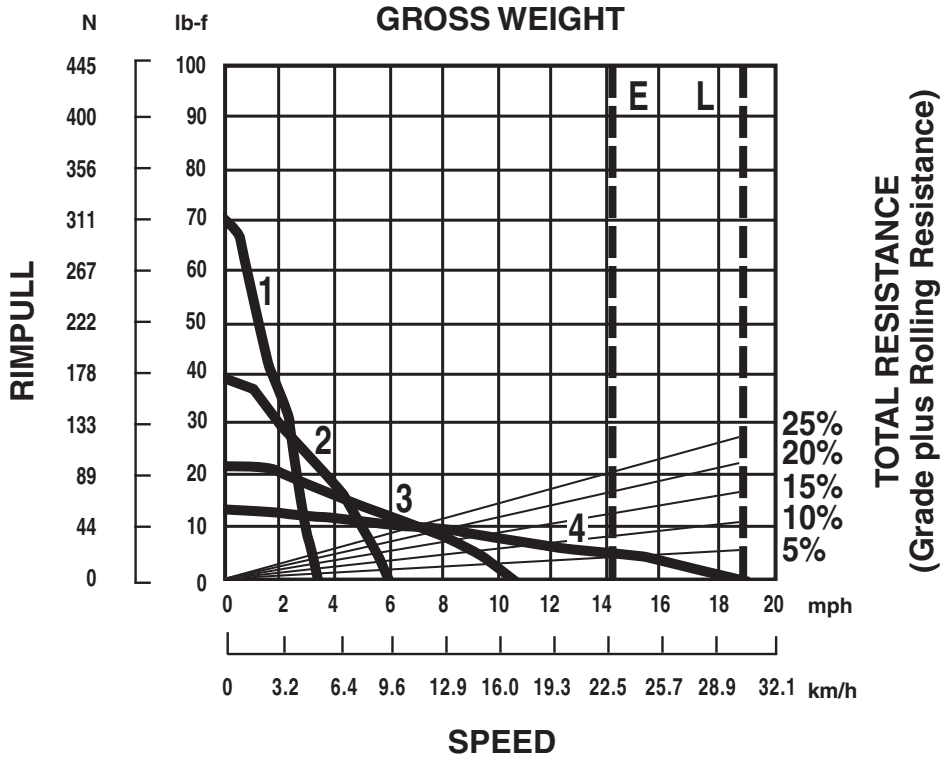

**KEY**

- 1 — 1st Gear
- 2 — 2nd Gear
- 3 — 3rd Gear
- 4 — 4th Gear

**KEY**

- E — Empty 38 500 kg (84,878 lb)
- L — Loaded 51 000 kg (112,436 lb)

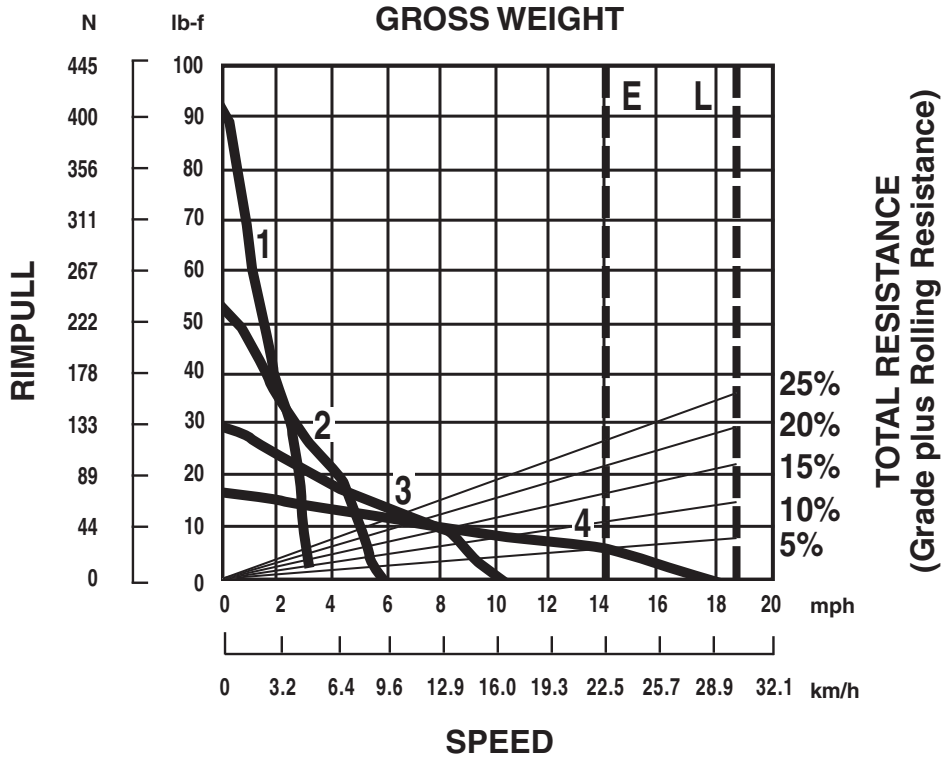

**KEY**

1 — 1st Gear  
 2 — 2nd Gear  
 3 — 3rd Gear  
 4 — 4th Gear

**KEY**

E — Empty 50 209 kg (110,711 lb)  
 L — Loaded 67 409 kg (148,637 lb)



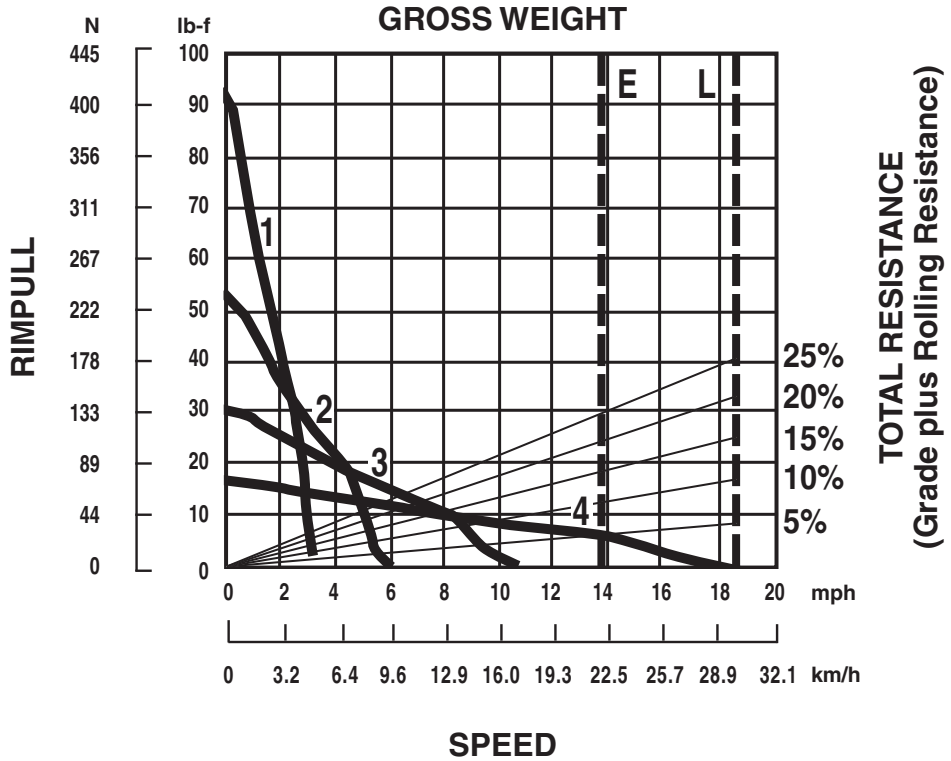

**KEY**

- 1 — 1st Gear
- 2 — 2nd Gear
- 3 — 3rd Gear
- 4 — 4th Gear

**KEY**

- E — Empty 55 575 kg (122,522 lb)
- L — Loaded 75 575 kg (166,614 lb)



MODEL	AD30		AD45B		AD55B	
Engine Model	C15 ACERT ATAAC		C18 ACERT ATAAC		C27 ACERT	
Engine Power:						
— Gross	304 kW	<b>408 hp</b>	438 kW	<b>587 hp</b>	579/600 kW+	<b>776/805 hp+</b>
— Net	281 kW	<b>377 hp</b>	414 kW	<b>555 hp</b>	540/560 kW+	<b>725/751 hp+</b>
Tire Size	<b>26.5 × R25 VSNT E4</b>		<b>29.5 × R29 VSNT E4</b>		<b>35 × 65 R33 VSNT E4</b>	
Nominal Payload Capacity	30 000 kg	<b>66,138 lb</b>	45 000 kg	<b>86,772 lb</b>	55 000 kg	<b>121,254 lb</b>
Gross Machine Operating Weight	60 000 kg	<b>132,277 lb</b>	85 000 kg	<b>187,393 lb</b>	105 000 kg	<b>231,485 lb</b>
Body Capacity* — Dump Body	14.4 m <sup>3</sup>	<b>18.8 yd<sup>3</sup></b>	21.3 m <sup>3</sup>	<b>27.9 yd<sup>3</sup></b>	26.9 m <sup>3</sup>	<b>35.2 yd<sup>3</sup></b>
Weight Distribution:						
— Empty (Front/Rear)	<b>67.50%/32.50%</b>		<b>70.00%/30.00%</b>		<b>68.40%/31.60%</b>	
— Loaded (Front/Rear)	<b>44.20%/55.80%</b>		<b>46.00%/54.00%</b>		<b>50.40%/49.60%</b>	
Length — Overall	10 153 mm	<b>400"</b>	11 194 mm	<b>441"</b>	12 040 mm	<b>474"</b>
Width — Overall	2690 mm	<b>106"</b>	3000 mm	<b>118"</b>	3346 mm	<b>132"</b>
Height:						
— Overall Body Raised	5602 mm	<b>221"</b>	6357 mm	<b>250"</b>	6969 mm	<b>274"</b>
— Top of ROPS	2600 mm	<b>102"</b>	2817 mm	<b>111"</b>	3278 mm	<b>129"</b>
— Loading Height	2385 mm	<b>94"</b>	2925 mm	<b>115"</b>	3045 mm	<b>120"</b>
— Ground Clearance	400 mm	<b>16"</b>	441 mm	<b>17"</b>	393 mm	<b>16"</b>
Clearance Radius:						
— Outer	8571 mm	<b>226"</b>	9291 mm	<b>366"</b>	10 005 mm	<b>394"</b>
— Inner	5030 mm	<b>115"</b>	5310 mm	<b>209"</b>	5540 mm	<b>218"</b>
Angle:						
— Articulation	<b>±42.5°</b>		<b>±42.5°</b>		<b>±42.5°</b>	
— Oscillation	<b>±10.0°</b>		<b>±10.0°</b>		<b>±10.0°</b>	
Body Hoist Cycle Time:						
Raise Time	<b>10.5 Sec.</b>		<b>16.0 Sec.</b>		<b>12.0 Sec.</b>	
Dump Time	<b>11.2 Sec.</b>		<b>21.0 Sec.</b>		<b>24.0 Sec.</b>	
Total Cycle Time	<b>21.7 Sec.</b>		<b>37.0 Sec.</b>		<b>36.0 Sec.</b>	
Travel Speeds:	<b>km/h</b>	<b>mph</b>	<b>km/h</b>	<b>mph</b>	<b>km/h</b>	<b>mph</b>
Forward — 1st	6.8	<b>4.2</b>	8.0	<b>4.9</b>	6.6	<b>4.1</b>
— 2nd	12.3	<b>7.6</b>	10.9	<b>6.8</b>	9.3	<b>5.8</b>
— 3rd	22.3	<b>13.8</b>	15.1	<b>9.4</b>	12.5	<b>7.5</b>
— 4th	40.8	<b>25.4</b>	20.6	<b>12.8</b>	19.8	<b>10.4</b>
— 5th		—	28.1	<b>17.4</b>	22.7	<b>14.1</b>
— 6th		—	38.1	<b>23.7</b>	30.7	<b>19.1</b>
— 7th		—	52.0	<b>32.3</b>	41.5	<b>25.8</b>
Reverse — 1st	7.8	<b>4.8</b>	7.5	<b>4.6</b>	8.7	<b>5.4</b>
— 2nd		—	10.1	<b>6.3</b>		—
Refill Capacity:						
Fuel	500 L	<b>132 U.S. gal</b>	764 L	<b>202 U.S. gal</b>	960 L	<b>254 U.S. gal</b>
Engine Crankcase with Filter	38 L	<b>10 U.S. gal</b>	64 L	<b>17 U.S. gal</b>	99 L	<b>26 U.S. gal</b>
Transmission	67 L	<b>18 U.S. gal</b>	60 L	<b>16 U.S. gal</b>	53 L	<b>14 U.S. gal</b>
Hydraulic Tank	145 L	<b>38 U.S. gal</b>	266 L	<b>70 U.S. gal</b>	258 L	<b>68 U.S. gal</b>
Cooling System	76 L	<b>20 U.S. gal</b>	85 L	<b>23 U.S. gal</b>	138 L	<b>37 U.S. gal</b>

\*Heaped SAE 2:1.

+Dual Horsepower — Higher horsepower for different gears.

**Articulated Trucks**

<b>Model</b>	<b>AD30</b>		<b>AD45B</b>		<b>AD55B</b>	
Nominal Payload Capacity	30 000 kg	<b>66,138 lb</b>	45 000 kg	<b>86,772 lb</b>	55 000 kg	<b>121,254 lb</b>
Gross Machine Operating Weight	60 000 kg	<b>132,277 lb</b>	85 000 kg	<b>187,393 lb</b>	105 000 kg	<b>231,485 lb</b>
Body Capacity* — Dump Body	14.4 m <sup>3</sup>	<b>18.8 yd<sup>3</sup></b>	21.3 m <sup>3</sup>	<b>27.9 yd<sup>3</sup></b>	26.9 m <sup>3</sup>	<b>35.2 yd<sup>3</sup></b>
Overall Length	10 153 mm	<b>400"</b>	11 194 mm	<b>441"</b>	12 040 mm	<b>474"</b>
Overall Width	2690 mm	<b>106"</b>	3000 mm	<b>118"</b>	3346 mm	<b>132"</b>
Overall Height	2600 mm	<b>102"</b>	2817 mm	<b>111"</b>	3278 mm	<b>129"</b>
Ground Clearance	400 mm	<b>16"</b>	441 mm	<b>17"</b>	393 mm	<b>16"</b>
Frame Oscillation	<b>±10.0°</b>		<b>±10.0°</b>		<b>±10.0°</b>	

\*2:1 per SAE.

<b>Model</b>	<b>Body Type</b>	<b>SAE Body Capacity</b>	
		<b>m<sup>3</sup></b>	<b>yd<sup>3</sup></b>
<b>AD30</b>	Dump	11.3	<b>14.8</b>
	Dump	14.4	<b>18.8</b>
	Dump	17.5	<b>22.9</b>
	Wide Body	16.8	<b>21.9</b>
	Ejector Body	15.2	<b>19.9</b>
	Ejector Body	17.3	<b>22.6</b>
<b>AD45B</b>	Dump	18.0	<b>23.6</b>
	Dump	21.3	<b>27.9</b>
	Dump	25.1	<b>32.8</b>
	Ejector Body	22.9	<b>29.9</b>

<b>Model</b>	<b>Body Type</b>	<b>SAE Body Capacity</b>	
		<b>m<sup>3</sup></b>	<b>yd<sup>3</sup></b>
<b>AD55B</b>	Dump	26.9	<b>35.2</b>
	Dump	32.6	<b>42.6</b>
	Dump	33.8	<b>44.2</b>
	Dump	36.6	<b>47.9</b>
	Ejector Body	26.9	<b>35.2</b>
	Ejector Body	29.3	<b>38.4</b>

\*Heaped SAE 2:1.

**Turning Dimensions**

**Articulated Trucks**

<b>Model — Standard Body</b>	<b>AD30</b>		<b>AD45B</b>		<b>AD55B</b>	
Clearance Radius — Outer	8571 mm	<b>226"</b>	9291 mm	<b>366"</b>	10 005 mm	<b>394"</b>
Clearance Radius — Inner	5030 mm	<b>115"</b>	5310 mm	<b>209"</b>	5540 mm	<b>218"</b>
Angle — Articulation	<b>±42.5°</b>		<b>±42.5°</b>		<b>±42.5°</b>	

<b>Model — Ejector Body</b>	<b>AD30</b>		<b>AD45B</b>		<b>AD55B</b>	
Clearance Radius — Outer	8571 mm	<b>226"</b>	9291 mm	<b>366"</b>	10 005 mm	<b>394"</b>
Clearance Radius — Inner	4935 mm	<b>194"</b>	5210 mm	<b>205"</b>	5540 mm	<b>218"</b>
Angle — Articulation	<b>±42.5°</b>		<b>±42.5°</b>		<b>±42.5°</b>	

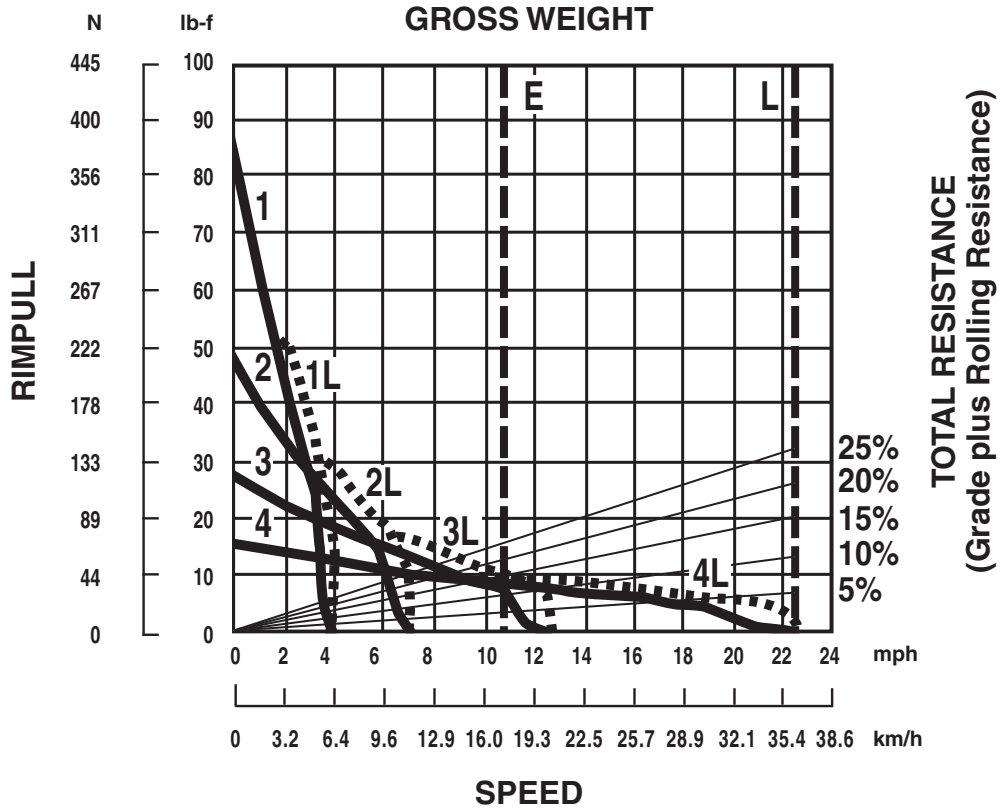

KEY

- 1 — 1st Gear
- 2 — 2nd Gear
- 3 — 3rd Gear
- 4 — 4th Gear

KEY

- E — Empty 28 870 kg (63,647 lb)
- L — Loaded 60 000 kg (132,277 lb)

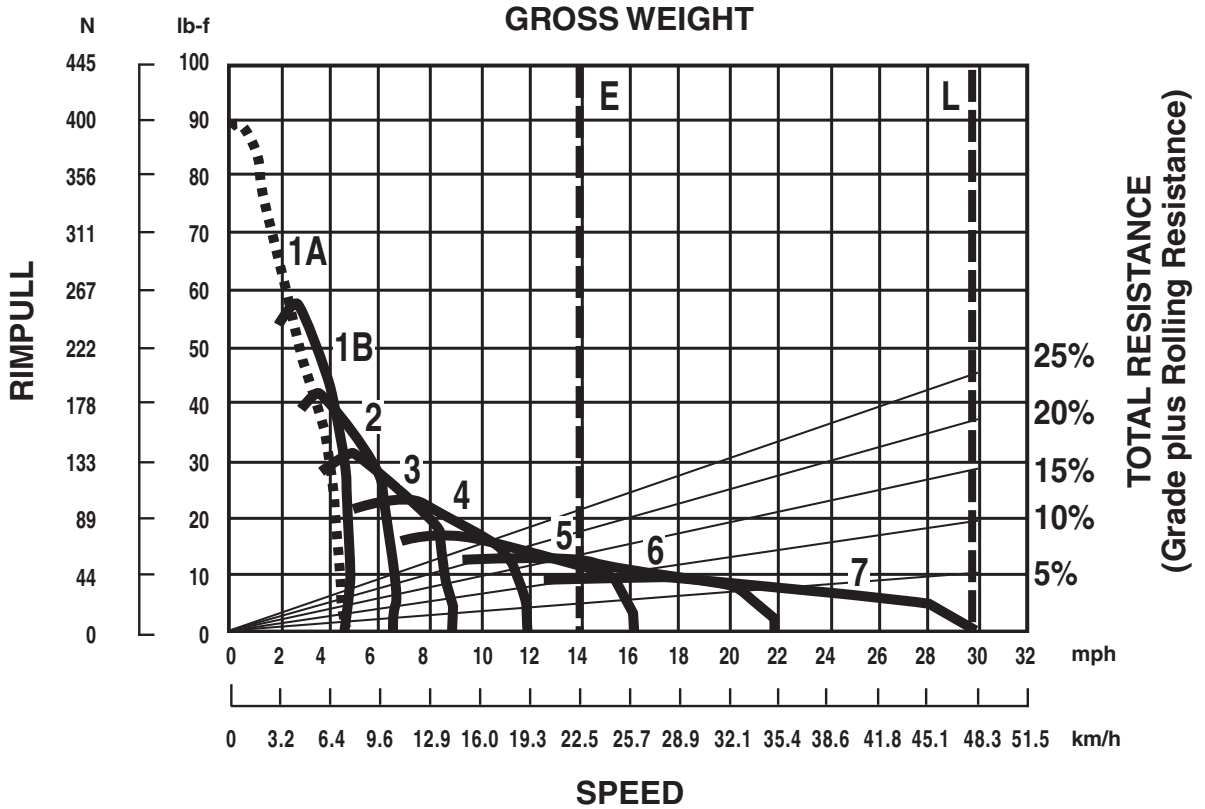

**KEY**

- 1A — 1st Gear Torque Converter Drive
- 1B — 1st Gear Direct Drive
- 2 — 2nd Gear Direct Drive
- 3 — 3rd Gear Direct Drive
- 4 — 4th Gear Direct Drive
- 5 — 5th Gear Direct Drive
- 6 — 6th Gear Direct Drive
- 7 — 7th Gear Direct Drive

**KEY**

- E — Empty 40 000 kg (88,185 lb)
- L — Loaded 85 000 kg (187,393 lb)

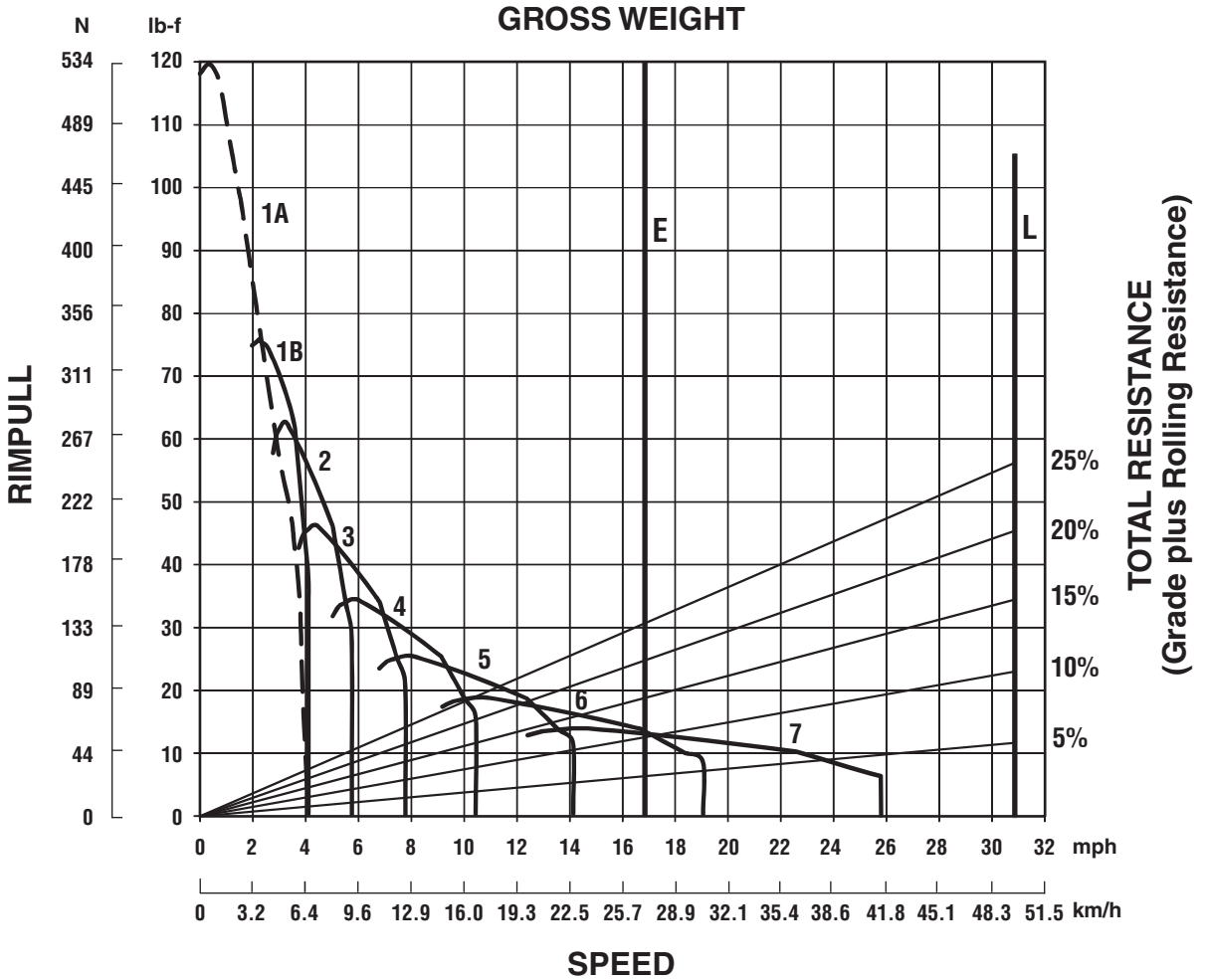

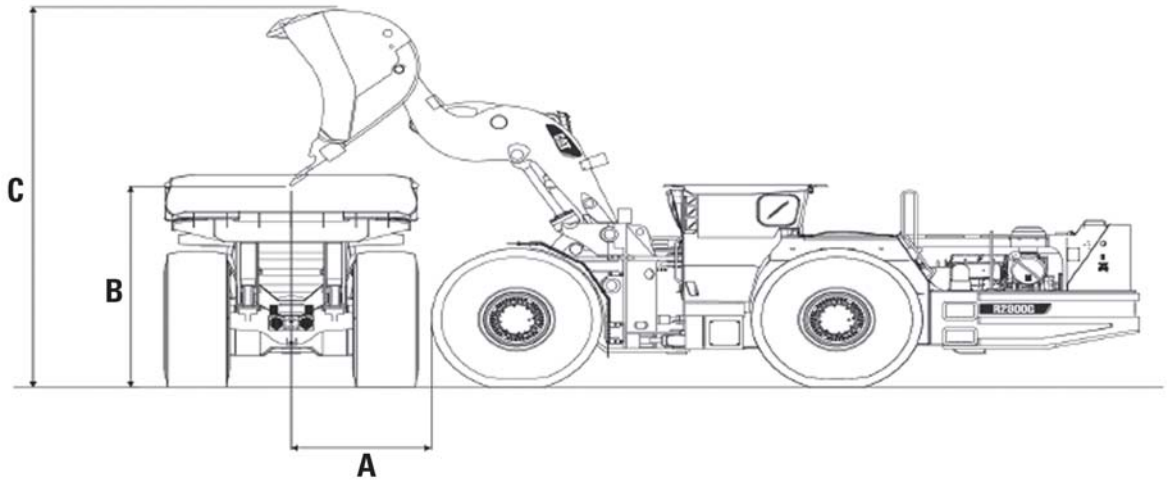

Loader	Target	A		B		C	
R1300G	AD30	1583 mm	62"	1560 mm	61"	4302 mm	169"
R1600G	AD30	1408 mm	55"	2207 mm	87"	5168 mm	204"
R1600G	AD45B	1408 mm	55"	2207 mm	87"	5168 mm	204"
R1700G	AD30	1685 mm	66"	2477 mm	98"	5606 mm	221"
R1700G	AD45B	1685 mm	66"	2477 mm	98"	5606 mm	221"
R1700G	AD55B	1685 mm	66"	2477 mm	98"	5606 mm	221"
R2900G	AD45B	1656 mm	65"	2868 mm	113"	6179 mm	243"
R2900G	AD55B	1656 mm	65"	2868 mm	113"	6179 mm	243"

**NOTE:** R1700G rated payload 14 000 kg (**30,870 lb**) is for tramming only. Truck loading capacity is 12 500 kg (**27,563 lb**).

R2900G XTRA rated payload 20 000 kg (**44,100 lb**) is for tramming only. Truck loading capacity is 17 200 kg (**37,926 lb**).

# HYDROMECHANICAL WORK TOOLS

## CONTENTS

### HYDRAULIC HAMMERS

Features:	
H35D S-H65D S	17-2
H70-H100	17-2
H115 S-H180D S	17-3
Applications	17-3
Tool Selection	17-4
Specifications	17-6
Selection	17-9
Productivity	17-12

### MOBILE SCRAP AND DEMOLITION SHEARS

Applications	17-15
Guarding Recommendation	17-15
Shearing Capability Table	17-16
Specifications	17-17
Matching Guide	17-19

### MULTI-PROCESSORS

Features	17-21
Applications	17-21
Matching Guide	17-21
Jaw Types	17-21
Guarding Recommendation	17-22
Specifications	17-22
Cutting Capacity	17-28

### CONTRACTOR'S GRAPPLES

Features	17-29
Applications	17-29
Guarding Recommendation	17-29
Matching Guide	17-29
Specifications	17-30

### MULTI-GRAPPLES

Features	17-31
Matching Guide	17-31
Specifications	17-31

### ORANGE PEEL GRAPPLES

Features (North America Version)	17-33
Europe, Africa, Middle East Version	17-36
Specifications (North America Version)	17-33
Europe, Africa, Middle East Version	17-37
Matching Guide (North America Version)	17-35
Europe, Africa, Middle East Version	17-41
Guarding Recommendation	17-35

### MULTI-FUNCTIONAL CONCRETE CRUSHERS

Features	17-42
Guarding Recommendation	17-42
Matching Guide	17-42
Specifications and Dimensions	17-43

### HYDRAULIC CONCRETE PULVERIZERS

Features	17-44
Guarding Recommendation	17-44
Matching Guide	17-44
Specifications and Dimensions	17-45



## HYDRAULIC HAMMERS

### H35D S-H65D S Hammer Features:

- **One Piece Body** results in reduced hammer components, which minimizes service time required.
- **Tubular Accumulator** eliminates accumulator retention screws, which improves hammer efficiency while simplifying maintenance.
- **Distributor** provides high oil volume for greater blow frequency.
- **Pressure Adjusting Valve (PAV)** assures that all blows are delivered at a constant blow energy.
- **Long Heavy Piston** delivers maximum impact energy and minimizes recoil forces to carrier.
- **Replaceable Piston Sleeve** reduces the cost to repair in event of catastrophic failure, simplifies serviceability.
- **Shock Isolation** feature significantly reduces shock loads transferred to the machine during hammer operation, improve operator comfort and extend life of critical machine components.
- **Round Tool Retaining Pin with Locking Mechanism** means no loose parts when changing tool.
- **Single Piece Upper & Lower Tool Bushing with Integral Tool Stop** simplifies product maintenance by allowing field replacement of all tool wear components.
- **Dust Seal** helps prevent foreign material from entering the housing, which reduces the wear on the power cell and other major components.
- **Sound Suppressed** version is standard for all D Series small hammer models.

### H70-H100 Hammer Features:

- **Low Pressure Accumulator** provides the energy for the piston power stroke.
- **Custom Side Plates** designed for Cat® carrier geometry. Protects power cell. Allows for complete folding of the boom on side-shift backhoes.
- **High Pressure Accumulator** dampens pressure peaks and pulsation, thus protecting carrier hydraulic system. Recovers rebound energy in hard material for greater impact power.
- **Distributor** has high oil volume for ultra high blow frequency.
- **Pressure Adjusting Valve** assures that all blows are delivered at a constant blow energy.
- **Long Heavy Piston** delivers maximum impact energy and minimizes recoil forces to carrier.
- **Long Front End** ensures proper piston — tool alignment.
- **Slip Fit Thrust Ring** dissipates harmful shock loads in abusive applications and is rotatable for additional life.
- **Slip Fit Upper Tool Bushing** is rotatable for additional life and provides positive tool alignment.
- **Slip Fit Lower Tool Bushing** provides positive tool alignment, is field replaceable and rotatable. Grease retention grooves provide extended lubrication and wear indication.
- **Dust Seal** helps prevent foreign material from entering the housing, which reduces the wear on the power cell and other major components.
- **Sound Suppressed** versions available for all models.

**H115 S-H180D S Hammer Features:**

- **Shock Mount** isolates forces to protect the carrier.
- **Integrally Mounted Accumulator** dampens pressure peaks inside the hammer to protect the carrier hydraulic system, assist the piston in the power stroke, and allows checking/replacing nitrogen without removing the hammer.
- **Pressure Control Valve** allows hammer to strike with maximum fixed energy per blow.
- **Main Valve** directs the firing cycle and blocks the return port to protect the carrier hydraulics from pressure peaks.
- **Check Valve** maintains oil pressure in the accumulator when hammer is repositioned. This helps improve breaking efficiency (reduced waiting time).
- **Tie Rods** are heat torqued for easier tightening without torsion stresses.
- **Long Heavy Piston** minimizes recoil forces to protect hammer components and carrier structures.
- **Slip Fit Thrust Ring** dissipates shock loads in abusive applications and is rotatable for longer life.
- **Plastic Wear Plates** on all four sides guide the power cell within the housing.
- **Blank Fire Protection** aided by auto-shutoff stops operation when no material is present to be broken. It increases hammer reliability and durability by eliminating high stress resulting from blank firing. (Available only in D Series models.)
- **Slip Fit Upper Tool Bushing** is rotatable for longer life and is replaceable. Guides the tool to optimize in-line piston/tool contact.
- **Slip Fit Sealed Lower Tool Bushing** provides positive tool alignment, is field replaceable and rotatable. It has grease retention grooves for extended lubrication and wear indication.
- **Sound Suppression** consists of housing dampening material, plugs and covers.
- **Autolube** available for all hammers.

**Hammer Applications:**

- **Sewer and Water** — The hammer can be used on pockets of rock that slow down production. Also good for breaking up old concrete pipes, manholes, etc.
- **Road Construction** — An essential tool during improvements and upgrading. The hammer works well on removing existing curbs, traffic islands, ramps, or sections of concrete. With correct tool, it can cut asphalt.
- **Bridge Renewal** — Hammers are used to remove old bridge surfaces, railing supports, abutments, retaining walls, etc.
- **Demolition** — The hammer-equipped excavator is often a key helper in industrial demolition. It can break up fallen wall and floor sections as well as foundations, or other brick and concrete structures.
- **Mining and Aggregate** — Hammers can break oversized material to avoid secondary blasting, and size riprap. Hammers can be installed near crushers to prepare material for crushing.
- **Trenching/Primary Excavation** — In soft or layered materials, the hydraulic hammer with amoil or chisel point is an effective tool in excavation.
- **Direct Quarrying** — In many types of limestone, direct quarrying with hydraulic hammers can prove cost effective, especially where blasting is prohibited or restricted.

A hammer need not be full time attachment for these applications. It can be replaced by a bucket in a short time, allowing the machine to be used for digging, loading, lifting, or other tasks.

Consult your Cat dealer for advice on correct sizing, installation and tool selection.

**NOTE:** Internal components of hammers are machined to close tolerances and require clean oil with full lubricating properties. When operating in high ambient temperatures or extreme temperature applications (e.g. foundries), higher viscosities are recommended to extend hammer life and improve performance. Hammers tend to shear multigrade mineral oil so that oil viscosity decreases. Contamination, water in oil, and decreased viscosity lead to earlier oil deterioration and the need for more frequent oil changes than normally recommended for the excavator. Extra care should be taken to avoid the entry of dust or dirt when installing or removing a hammer in the field.

**Standard Tools**

**Special Tools**

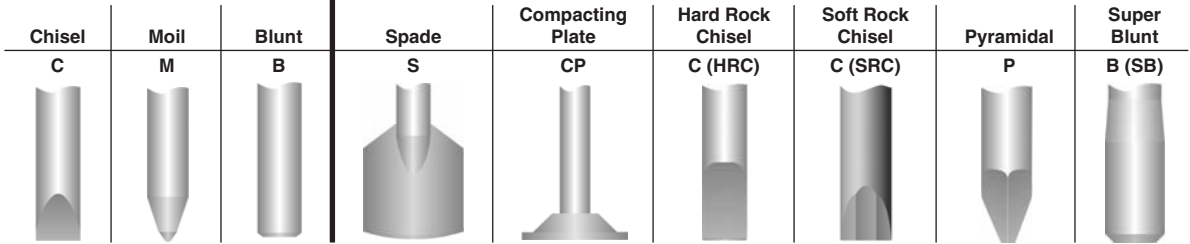

	H35D S		H45D S		H55D S		H65D S		H70 H70 S		H90C H90C S		H100 H100 S		H115 S		H120C S		H130 S		H140D S		H160D S		H180D S			
<b>1. Roadbuilding/Construction</b>																												
Breaking of road surface	C,M,S	C,M,S	C,M,S	C,M,S	C,M,S	C,M,S	C,M,S	C,M,S	C,M,S	C,M,S	C,M,S	C,M,S	C,M,S	C,M,S	C,M,P,S	C,M,P	C,M,P	C,M,P	C,M,P	C,M,P	C,M,P	C,M,P	C,M,P	C,M,P	C,M,P	C,M,P	C,M,P	C,M,P
Breaking uneven bedrock to lay a road														C,M	C,M,P	C,M,P	C,M,P	C,M,P	C,M,P	C,M,P	C,M,P	C,M,P	C,M,P	C,M,P	C,M,P	C,M,P	C,M,P	C,M,P
Primary breaking to prepare road bed																					C,M,P	C,M,P	C,M,P	C,M,P	C,M,P	C,M,P	C,M,P	C,M,P
Asphalt cutting to shape or area	C,S	C,S	C,S	C,S	C,S	C,S	C,S	C,S	C,S	C,S	C,S	C,S	C,S															
Trench excavation for drainage									C,M	C,M	C,M	C,M	C,M,P	C,M,P	C,M,P	C,M,P	C,M,P	C,M,P	C,M,P	C,M,P	C,M,P	C,M,P	C,M,P	C,M,P	C,M,P	C,M,P	C,M,P	C,M,P
Demolition of bridges	C,M	C,M	C,M	C,M	C,M	C,M	C,M	C,M	C,M	C,M	C,M	C,M	C,M	B,C,M,P	B,C,M,P	B,C,M,P	B,C,M,P	B,C,M,P	B,C,M,P	B,C,M,P	B,C,M,P	B,C,M,P	B,C,M,P	B,C,M,P	B,C,M,P	B,C,M,P	B,C,M,P	B,C,M,P
Heavily reinforced bridge pillars																					B	B	B	B	B	B	B	B
Compacting soils	CP	CP	CP	CP	CP	CP	CP	CP	CP	CP	CP	CP	CP	CP	CP	CP	CP	CP	CP	CP	CP	CP	CP	CP	CP	CP	CP	CP
Making holes (for traffic signs, lamp posts)	M	M	M	M	M	M	M	M	M	M	M	M	M	M	M	M	M	M	M	M	M	M	M	M	M	M	M	M
Breaking of frozen ground	C,M,S	C,M,S	C,M,S	C,M,S	C,M,S	C,M,S	C,M,S	C,M,S	C,M,S	C,M,S	C,M,S	C,M,S	C,M,S	C,M,S	C,M,P,S	C,M,P	C,M,P	C,M,P	C,M,P	C,M,P	C,M,P	C,M,P	C,M,P	C,M,P	C,M,P	C,M,P	C,M,P	C,M,P
<b>2. Demolition/housing development</b>																												
Demolition of concrete walls, roofs, floors	C,M	C,M	C,M	C,M	C,M	C,M	C,M	C,M	C,M	C,M	C,M	C,M	C,M	B,C,M,P	B,C,M,P	B,C,M,P	B,C,M,P	B,C,M,P	B,C,M,P	B,C,M,P	B,C,M,P	B,C,M,P	B,C,M,P	B,C,M,P	B,C,M,P	B,C,M,P	B,C,M,P	B,C,M,P
Demolition of light, reinforced concrete foundation [<0.5 m (19.7")]	M	M	M	M	M	M	M	M	M	M	M	M	M	B,M,P	B,M,P	B,M,P												
Brick walls	C,M	C,M	C,M	C,M	C,M	C,M	C,M	C,M	C,M	C,M	C,M	C,M	C,M	B,C,M,P	B,C,M,P	B,C,M,P	B,C,M,P	B,C,M,P	B,C,M,P	B,C,M,P	B,C,M,P	B,C,M,P	B,C,M,P	B,C,M,P	B,C,M,P	B,C,M,P	B,C,M,P	B,C,M,P
Rock trenches for mains/water supply/utilities									C,M	C,M	C,M	C,M	C,M,P	C,M,P	C,M,P	C,M,P	C,M,P	C,M,P	C,M,P	C,M,P	C,M,P	C,M,P	C,M,P	C,M,P	C,M,P	C,M,P	C,M,P	C,M,P
Rock excavation for foundation												C,M	C,M	C,M,P	C,M,P	C,M,P	C,M,P	C,M,P	C,M,P	C,M,P	C,M,P	C,M,P	C,M,P	C,M,P	C,M,P	C,M,P	C,M,P	C,M,P
Mass excavation of rock for industrial building bases																				C,M,P	C,M,P	C,M,P	C,M,P	C,M,P	C,M,P	C,M,P	C,M,P	C,M,P
Massive reinforced concrete foundations																					M,P	M,P	M,P	M,P	M,P	M,P	M,P	M,P
Separating rebar from concrete (for recycling)	C,M	C,M	C,M	C,M	C,M	C,M	C,M	C,M	C,M	C,M	C,M	C,M	C,M	B,C,M,P	B,C,M,P	B,C,M,P	B,C,M,P	B,C,M,P	B,C,M,P	B,C,M,P	B,C,M,P	B,C,M,P	B,C,M,P	B,C,M,P	B,C,M,P	B,C,M,P	B,C,M,P	B,C,M,P

**Standard Tools**

**Special Tools**

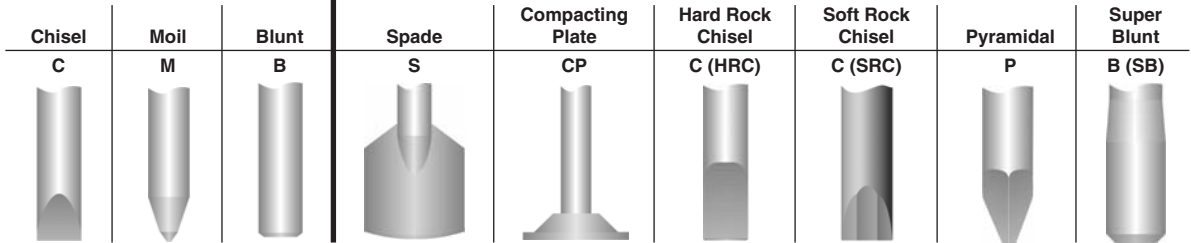

	H35D S	H45D S	H55D S	H65D S	H70 H70 S	H90C H90C S	H100 H100 S	H115 S	H120C S	H130 S	H140D S	H160D S	H180D S
<b>3. Quarrying/open cast mining</b>													
Secondary boulder breaking								B	B	B	B	B	B
Primary breaking of rock										C,M,P	C,M,P	C,M,P	C,M,P
Breaking oversizes on a crusher/ feeder/feed chute						C,M	C,M	B,C,M,P	B,C,M,P	B,C,M,P	B,C,M,P	B,C,M,P	
<b>4. Underground applications</b>													
Scaling					C	C	C	C					
<b>5. Metallurgical applications</b>													
Breaking of slag in casting ladles						C,M	C,M	C,M,P					
Breaking of slag in converter openings							C,M	C,M,P	C,M,P	C,M,P	C,M,P		
Cleaning of castings						C,M	C,M	C,M,P					
Breaking of massive steel slag												C,M,P	C,M,P
Breaking of aluminum electrolyze slag								C,M,P	C,M,P	C,M,P	C,M,P		
Breaking of refractory linings in furnaces	C,M	C,M	C,M	C,M	C,M	C,M	C,M						
<b>6. Other applications</b>													
Demolition/Rock breaking under water								C,M,P	C,M,P	C,M,P	C,M,P	C,M,P	C,M,P

Model	H35D S		H45D S		H55D S		H65D S	
Working weight <sup>1</sup>	103 kg	<b>227 lb</b>	145 kg	<b>320 lb</b>	199 kg*/ 240 kg**	<b>438 lb*/ 529 lb**</b>	271 kg*/ 295 kg**	<b>598 lb*/ 650 lb**</b>
Impact frequency <sup>2</sup>	<b>800-2900 bpm</b>		<b>900-2500 bpm</b>		<b>1022-2300 bpm</b>		<b>700-2000 bpm</b>	
Hammer operating pressure <sup>3</sup>	16 500 kPa	<b>2393 psi</b>	16 500 kPa	<b>2393 psi</b>	17 000 kPa	<b>2465 psi</b>	17 000 kPa	<b>2465 psi</b>
Carrier relief pressure <sup>4</sup>	24 000 kPa	<b>3480 psi</b>	23 000 kPa	<b>3335 psi</b>	23 000 kPa	<b>3335 psi</b>	24 000 kPa	<b>3480 psi</b>
Acceptable oil flow	12-35 L/min	<b>3-9 gpm</b>	25-55 L/min	<b>7-15 gpm</b>	40-85 L/min	<b>11-22 gpm</b>	40-105 L/min	<b>11-28 gpm</b>
Maximum back pressure	3000 kPa	<b>435 psi</b>	3000 kPa	<b>435 psi</b>	2000 kPa	<b>290 psi</b>	2000 kPa	<b>290 psi</b>
Line size (minimum)								
ID pressure	12.9 mm	<b>0.51"</b>	12 mm	<b>0.47"</b>	15 mm	<b>0.59"</b>	15 mm	<b>0.59"</b>
ID return	12.9 mm	<b>0.51"</b>	12 mm	<b>0.47"</b>	15 mm	<b>0.59"</b>	15 mm	<b>0.59"</b>
Carrier weight class	1.1-2.4 t	<b>2430- 5300 lb</b>	1.5-3.2 t	<b>3310- 7060 lb</b>	2.5-4.5 t	<b>5500- 9900 lb</b>	3-6.5 t	<b>6610- 14,300 lb</b>

\*Pin-On Version.

\*\*Flat Top Version.

Model	H70/H70 S		H90C/H90C S		H100/H100 S	
Working weight <sup>1</sup>	430/435 kg	<b>948/959 lb</b>	590/600 kg	<b>1298/1320 lb</b>	820/830 kg	<b>1804/1826 lb</b>
Impact frequency <sup>2</sup>	<b>600-1850 bpm</b>		<b>500-1450 bpm</b>		<b>430-1300 bpm</b>	
Hammer operating pressure <sup>3</sup>	14 000 kPa	<b>2031 psi</b>	13 500 kPa	<b>1960 psi</b>	14 500 kPa	<b>2100 psi</b>
Carrier relief pressure <sup>4</sup>	21 000 kPa	<b>3045 psi</b>	21 000 kPa	<b>3045 psi</b>	21 000 kPa	<b>3045 psi</b>
Acceptable oil flow	50-150 L/min	<b>13-39 gpm</b>	60-150 L/min	<b>16-39 gpm</b>	60-120 L/min	<b>16-31 gpm</b>
Maximum back pressure	3000 kPa	<b>435 psi</b>	2000 kPa	<b>290 psi</b>	1000 kPa	<b>145 psi</b>
Line size (minimum)						
ID pressure	25 mm	<b>1"</b>	25 mm	<b>1"</b>	25 mm	<b>1"</b>
ID return	25 mm	<b>1"</b>	25 mm	<b>1"</b>	25 mm	<b>1"</b>
Carrier weight class	5-8 t	<b>11,000- 17,600 lb</b>	7-12 t	<b>15,400- 26,400 lb</b>	8-14 t	<b>17,600- 30,800 lb</b>

<sup>1</sup> Includes power cell, side plates/housing, average mounting bracket, where required, and standard tool.

<sup>2</sup> Approximate value, actual impact frequency depends on oil flow, oil viscosity, temperature, and hardness of material to be broken.

<sup>3</sup> Approximate value, operating pressure depends on oil flow, oil viscosity, temperature, material to be broken, and back pressure. Operating pressure is the result of correct low pressure adjustment.

<sup>4</sup> Approximate value, exact value depends on installation parameters.

Oil temperature working range for all models: -20° C to +80° C (-4° F to +176° F).

Oil viscosity at operating oil temperature: 15 to 1000 cSt.

Model	H115 S		H120C S		H130 S	
Working weight <sup>1</sup>	1000 kg	<b>2200 lb</b>	1300 kg	<b>2870 lb</b>	1700 kg	<b>3740 lb</b>
Impact frequency <sup>2</sup>	<b>370-800 bpm</b>		<b>350-620 bpm</b>		<b>320-600 bpm</b>	
Hammer operating pressure <sup>3</sup>	14 000 kPa	<b>2031 psi</b>	14 000 kPa	<b>2031 psi</b>	14 000 kPa	<b>2031 psi</b>
Carrier relief pressure <sup>4</sup>	21 000 kPa	<b>3045 psi</b>	21 000 kPa	<b>3045 psi</b>	21 000 kPa	<b>3045 psi</b>
Acceptable oil flow	70-130 L/min	<b>18-34 gpm</b>	100-170 L/min	<b>26-45 gpm</b>	120-220 L/min	<b>31-57 gpm</b>
Maximum back pressure	1000 kPa	<b>145 psi</b>	1000 kPa	<b>145 psi</b>	1000 kPa	<b>145 psi</b>
Line size (minimum)						
ID pressure	25 mm	<b>1"</b>	25 mm	<b>1"</b>	25 mm	<b>1"</b>
ID return	25 mm	<b>1"</b>	25 mm	<b>1"</b>	32 mm	<b>1.25"</b>
Carrier weight class	12-20 t	<b>26,400-44,000 lb</b>	17-26 t	<b>37,400-57,200 lb</b>	19-32 t	<b>41,800-70,400 lb</b>

Model	H140D S		H160D S		H180D S	
Working weight <sup>1</sup>	2350 kg	<b>5170 lb</b>	3150 kg	<b>6946 lb</b>	3900 kg	<b>8600 lb</b>
Impact frequency <sup>2</sup>	<b>350-600 bpm</b>		<b>380-560 bpm</b>		<b>400-505 bpm</b>	
Hammer operating pressure <sup>3</sup>	16 000 kPa	<b>2321 psi</b>	16 000 kPa	<b>2321 psi</b>	16 000 kPa	<b>2321 psi</b>
Carrier relief pressure <sup>4</sup>	21 000 kPa	<b>3045 psi</b>	21 000 kPa	<b>3045 psi</b>	21 000 kPa	<b>3045 psi</b>
Acceptable oil flow	160-230 L/min	<b>42-60 gpm</b>	220-310 L/min	<b>58-82 gpm</b>	250-330 L/min	<b>67-88 gpm</b>
Maximum back pressure	1000 kPa	<b>145 psi</b>	1000 kPa	<b>145 psi</b>	1000 kPa	<b>145 psi</b>
Line size (minimum)						
ID pressure	25 mm	<b>1"</b>	25 mm	<b>1"</b>	32 mm	<b>1.25"</b>
ID return	32 mm	<b>1.25"</b>	32 mm	<b>1.25"</b>	36 mm	<b>1.42"</b>
Carrier weight class	25-40 t	<b>55,000-88,000 lb</b>	32-55 t	<b>70,400-121,000 lb</b>	40-75 t	<b>132,000-166,000 lb</b>

<sup>1</sup> Includes power cell, side plates/housing, average mounting bracket, where required, and standard tool.

<sup>2</sup> Approximate value, actual impact frequency depends on oil flow, oil viscosity, temperature, and hardness of material to be broken.

<sup>3</sup> Approximate value, operating pressure depends on oil flow, oil viscosity, temperature, material to be broken, and back pressure. Operating pressure is the result of correct low pressure adjustment.

<sup>4</sup> Approximate value, exact value depends on installation parameters.

Oil temperature working range for all models: -20° C to +80° C (-4° F to +176° F).

Oil viscosity at operating oil temperature: 15 to 1000 cSt.

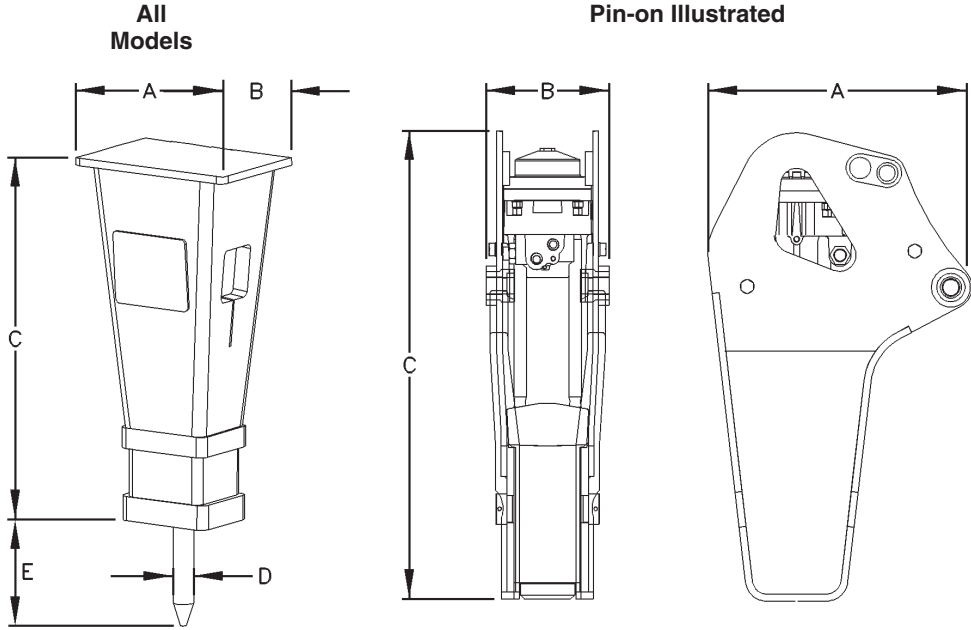

Model	A		B		C		D		E	
	mm	in	mm	in	mm	in	mm	in	mm	in
H180D S	730	28.7	730	28.7	2478	97.4	174	7.0	542	21.0
H160D S	730	28.7	730	28.7	2369	93.3	160	6.3	589	23.2
H140D S	585	23.0	540	21.3	2167	85.3	140	5.5	454	17.9
H130 S	585	23.0	540	21.3	1885	74.1	130	5.1	397	15.6
H120C S	585	23.0	540	21.3	1783	70.1	115	4.5	357	14.1
H115 S	585	23.0	540	21.3	1625	63.9	106	4.2	390	15.4
H100	585	23.0	540	21.3	1397	54.9	95	3.7	459	18.1
H100 S	585	23.0	540	21.3	1394	54.8	95	3.7	459	18.1
H90C	510	20.1	380	15.0	1286	50.6	84	3.3	417	16.4
H90C S	520	20.5	400	15.7	1294	50.9	84	3.3	417	16.4
H90C (pin-on)	749	29.4	348	13.7	1325	52.1	84	3.3	417	16.4
H70	470	18.5	380	15.0	1134	44.6	70	2.8	402	15.8
H70 S	520	20.5	400	15.7	1150	45.3	70	2.8	390	15.3
H70 (pin-on)	690	27.1	348	13.7	1228	48.3	70	2.8	355	14.0
H65D S	535	21.0	415	12.0	895	35.0	65	2.6	330	13.0
H65D S (pin-on)	454	17.9	300	11.8	1055	41.5	65	2.6	330	13.0
H55D S	450	18.0	325	13.0	820	32.0	56	2.2	299	11.8
H55D S (pin-on)	429	16.9	300	11.8	997	39.3	56	2.2	299	11.8
H45D S	330	13.0	280	11.0	713	28.1	48	1.9	233	9.2
H35D S	320	12.6	280	11.0	621	24.4	40	1.6	221	8.7

## Principles of Selection

Key to the successful sale of a hammer is proper hammer selection.

### Background Information

Collection of background information is the first step. The following information will assist in being sure the customer receives the correct hammer and that he has a positive hammer experience. The following issues should be examined.....

1. If any, what brand and model hammer was previously used and how did the hammer perform?
2. What % of time will the hammer be used on the machine?
3. Will the hammer be used in primary breaking or secondary breaking? (mainly an issue for large hammers)
4. What machine will the hammer be used on and what are the hydraulic flow and pressures of this machine?
5. What is the type of material to be broken and production required from the hammer? (best to obtain this from the end user but a table is available at the end of this section)

### Hammer Selection Process

1. Using Cat carrier matching matrix on next page identify 2 or 3 possible hammers for your application (for competitive carriers use carrier weight class as reference).
2. Compare machine/carrier flow and pressures to those of the hammer candidates to validate compatibility. Eliminate hammers outside carrier specs.
3. If hammer is to be used in primary breaking consider larger of hammer candidates.
4. Check productivity guidance tables at the back of this section. Identify hammer most compatible with requirements.
5. Determine if the application requires special hammer modifications, i.e. steel mill, underwater, tunneling, etc.

### Other Issues

Once the hammer has been chosen, other elements need to be considered to have a successful hammer experience.

1. Select the correct hammer tool for the application (see tool application chart in this section).
2. Check to be sure the correct hammer bracket and hoses are specified. Be sure correct carrier oil is specified for hammer use (particularly important in high ambient areas).
3. Consider supplemental carrier cooling in areas of high ambient temperature.

Actual operating pressure and back pressure **MUST** be checked when the hammer is fitted to the carrier (just as important if the hammer goes on a competitive carrier or is installed by the contractor at his shop).

### Guarding Recommendation

Hammers used in hazardous applications like demolition, quarrying, and scaling, can create a need for special operator guarding due to flying objects. When using a hammer, additional protective devices such as a front screen, Falling Object Guarding System (FOGS, includes top and front guarding), thick polycarbonate windshields or a combination of these is recommended by Caterpillar. Contact your Cat dealer for operator guarding options on your machine.



Model		H35D S	H45D S	H55D S (Flat Top)	H55D S (Pin-On)	H65D S (Flat Top)	H65D S (Pin-On)	H70/H70 S	H90C/ H90C S	H100/ H100 S
		kg lb	kg lb	kg lb	kg lb	kg lb	kg lb	kg lb	kg lb	kg lb
Minimum Carrier	kg lb	1100 2430	1500 3310	2500 5500	2500 5500	4500 9900	3000 6610	5000 11,000	7000 15,400	8000 17,600
Maximum Carrier	kg lb	2400 5300	3200 7060	6000 13,200	5200 11,500	9000 19,800	6500 14,300	8000 17,600	12 000 26,400	14 000 30,800
<b>Mini Excavators</b>										
301.6C		●	●							
301.8C		●	●							
302.5C			●	●#	●					
303C CR				●	●		●#			
303.5C CR				●	●		●			
304C CR				●	●	●	●			
305C CR				●	●	●	●			
<b>Skid Steer Loaders</b>										
216B					●		●			
226B					●		●			
232B					●		●			
236B					●		●			
242B					●		●			
246C					●		●			
248B					●		●			
252B					●		●			
256C					●		●			
262C					●		●			
268B					●		●			
272C					●		●			
<b>Multi Terrain Loaders</b>										
247B					●		●			
257B					●		●			
267B					●		●			
277C					●		●			
279C					●		●			
287C					●		●			
289C					●		●			
297C					●		●			
299C					●		●			
<b>Backhoe Loaders</b>										
416E						●*		●	●	
420E						●*		●	●	
422E						●*		●	●	
428E						●*		●	●	
430E						●*		●	●	
432E						●*		●	●	
434E						●*		●	●	
442E						●*		●	●	
444E						●*		●	●	

#Installation of add-on optional, counterweight to machine is required.

\*Special machine configuration required.

Caterpillar recommends the use of a suitable shield/guard system to insure operator has adequate protection from flying debris.

These matches are for general reference purposes for Cat machines only. When special boom and quick coupler arrangements are in use, these matches may not apply. When matching hammers to competitive carriers, selection should be made by carrier weight. Refer to the carrier weight range at the top of the table in order to determine the correct match.

Model		H65D S (Flat-Top)		H70/H70 S		H90C/H90C S		H100/H100 S		H115 S		H120C S		H130 S		H140D S		H160D S		H180D S	
		kg	lb	kg	lb	kg	lb	kg	lb	kg	lb	kg	lb	kg	lb	kg	lb	kg	lb	kg	lb
Minimum Carrier		3000	6610	5000	11,000	7000	15,400	8000	17,600	12 000	26,400	17 000	37,400	19 000	41,800	25 000	55,000	32 000	70,400	40 000	88,200
Maximum Carrier		6500	14,300	8000	17,600	12 000	26,400	14 000	30,800	20 000	44,000	26 000	57,200	32 000	70,400	40 000	88,000	55 000	121,000	75 000	165,000
<b>Hydraulic Excavators</b>																					
307D		●*		●		●															
308D CR		●*		●		●															
311D						●		●													
312D						●		●		●											
314D CR								●		●											
315D								●		●		●									
319D										●		●		●							
320D										●		●		●							
M313D								●		●		●									
M315D								●		●		●									
M316D								●		●		●									
M318D										●		●		●							
M322D										●		●		●							
321D CR												●		●							
323D												●		●							
324D												●		●		●					
328D CR														●		●					
329D												●		●		●					
336D														●		●		●			
345D																		●		●	
365C																				●	●

#Installation of add-on optional, counterweight to machine is required.

\*Special machine configuration required.

Caterpillar recommends the use of a suitable shield/guard system to insure operator has adequate protection from flying debris.

These matches are for general reference purposes for Cat machines only. When special boom and quick coupler arrangements are in use, these matches may not apply. When matching hammers to competitive carriers, selection should be made by carrier weight. Refer to the carrier weight range at the top of the table in order to determine the correct match.

<b>Hammer Models</b>	<b>Non-Reinforced Concrete</b>		<b>Reinforced Concrete</b>		<b>Sedimentary Rock</b>	<b>Volcanic Rock</b>		
H35D S	6-12 m <sup>3</sup>	<b>8-16 yd<sup>3</sup></b>	—	—	—	—	—	
H45D S	8-18 m <sup>3</sup>	<b>10-23 yd<sup>3</sup></b>	—	—	—	—	—	
H55D S	14-23 m <sup>3</sup>	<b>18-30 yd<sup>3</sup></b>	—	—	—	—	—	
H65D S	34-69 m <sup>3</sup>	<b>45-90 yd<sup>3</sup></b>	—	—	—	—	—	
H70/H70 S	65-107 m <sup>3</sup>	<b>85-140 yd<sup>3</sup></b>	19-46 m <sup>3</sup>	<b>25-60 yd<sup>3</sup></b>	—	—	—	
H90C/H90C S	69-122 m <sup>3</sup>	<b>90-160 yd<sup>3</sup></b>	38-61 m <sup>3</sup>	<b>50-80 yd<sup>3</sup></b>	—	—	—	
H100/H100 S	96-214 m <sup>3</sup>	<b>125-280 yd<sup>3</sup></b>	99-134 m <sup>3</sup>	<b>130-175 yd<sup>3</sup></b>	84-191 m <sup>3</sup>	<b>110-250 yd<sup>3</sup></b>	42-99 m <sup>3</sup>	<b>55-130 yd<sup>3</sup></b>
H115 S	115-287 m <sup>3</sup>	<b>150-375 yd<sup>3</sup></b>	107-184 m <sup>3</sup>	<b>140-240 yd<sup>3</sup></b>	126-229 m <sup>3</sup>	<b>165-300 yd<sup>3</sup></b>	57-115 m <sup>3</sup>	<b>75-150 yd<sup>3</sup></b>
H120C S	153-344 m <sup>3</sup>	<b>200-450 yd<sup>3</sup></b>	122-229 m <sup>3</sup>	<b>160-300 yd<sup>3</sup></b>	153-260 m <sup>3</sup>	<b>200-340 yd<sup>3</sup></b>	84-153 m <sup>3</sup>	<b>110-200 yd<sup>3</sup></b>
H130 S	210-375 m <sup>3</sup>	<b>275-490 yd<sup>3</sup></b>	153-268 m <sup>3</sup>	<b>200-350 yd<sup>3</sup></b>	191-306 m <sup>3</sup>	<b>250-400 yd<sup>3</sup></b>	103-210 m <sup>3</sup>	<b>135-275 yd<sup>3</sup></b>
H140D S	—	—	191-497 m <sup>3</sup>	<b>250-650 yd<sup>3</sup></b>	229-535 m <sup>3</sup>	<b>300-700 yd<sup>3</sup></b>	115-268 m <sup>3</sup>	<b>150-350 yd<sup>3</sup></b>
H160D S	—	—	229-650 m <sup>3</sup>	<b>300-850 yd<sup>3</sup></b>	268-688 m <sup>3</sup>	<b>350-900 yd<sup>3</sup></b>	153-459 m <sup>3</sup>	<b>200-600 yd<sup>3</sup></b>
H180D S	—	—	295-1301 m <sup>3</sup>	<b>385-1705 yd<sup>3</sup></b>	337-1345 m <sup>3</sup>	<b>440-1760 yd<sup>3</sup></b>	210-757 m <sup>3</sup>	<b>275-990 yd<sup>3</sup></b>

**Production rates listed are based on 8-hr shift**

The above figures are for general estimation purposes only and must not be used to guarantee any production figure to the customer. The actual working results may vary according to the quality and structure of the material to be broken, required degree of material size reduction, installation, condition of the carrier, conditions at the worksite, haulage of the broken material, skills of the operator etc.

The figures are for comparison and evaluation purposes only. Results will vary depending on operator, carrier and job conditions.

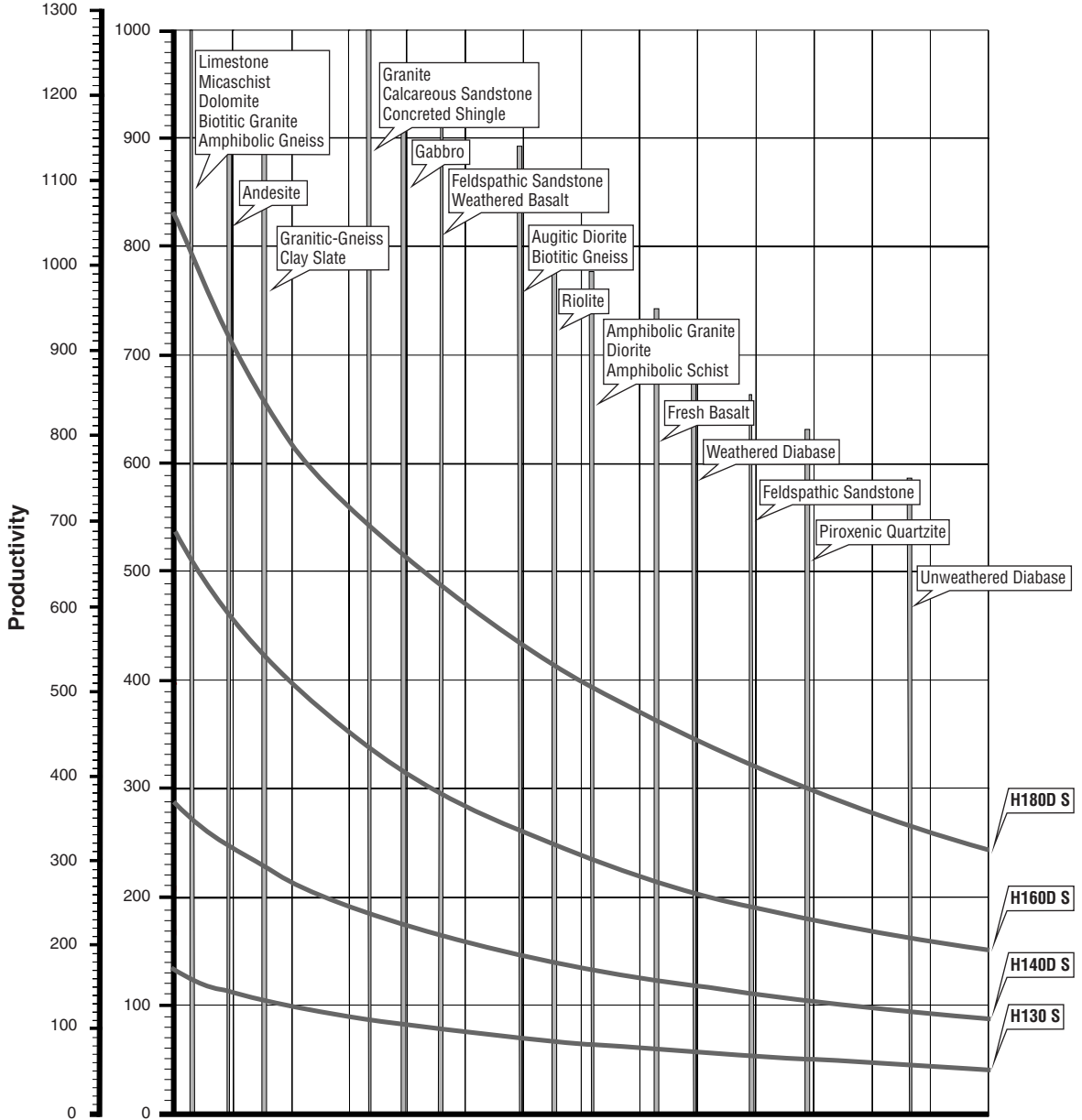

Bedding thickness 100-200 cm (40-80") or closely spaced vertical fractures

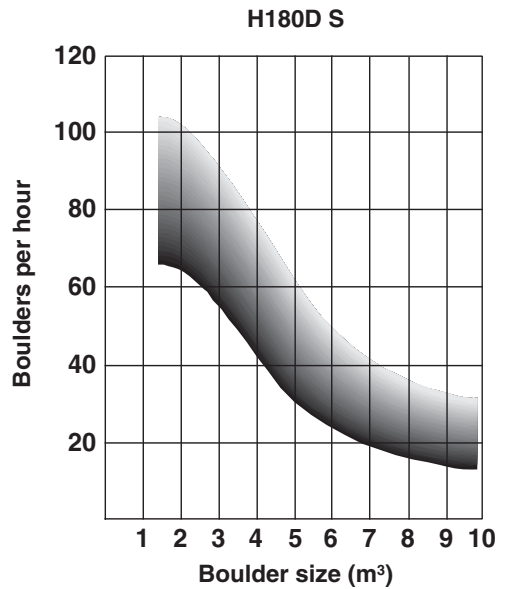
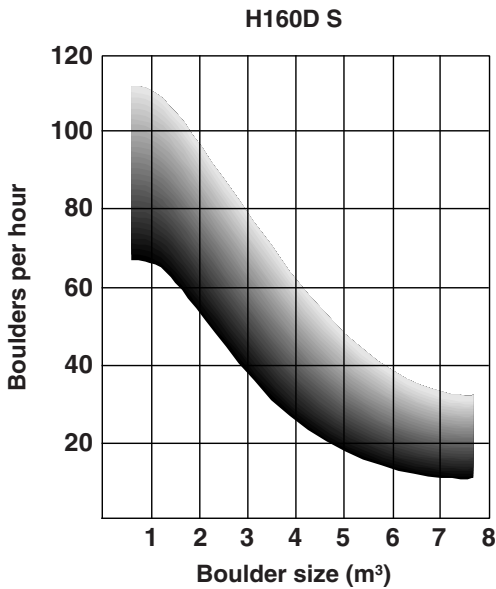
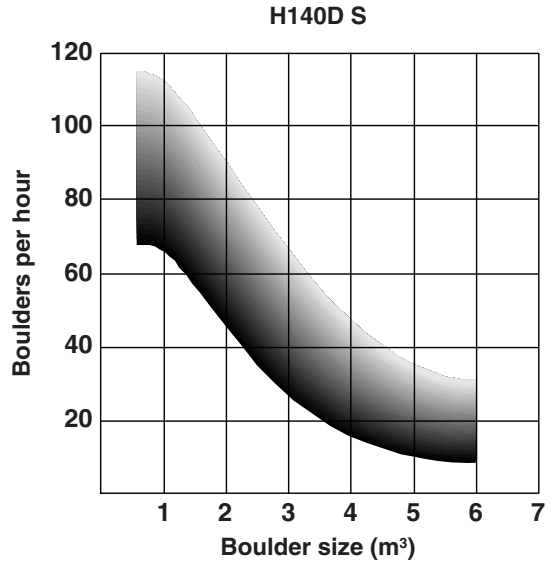
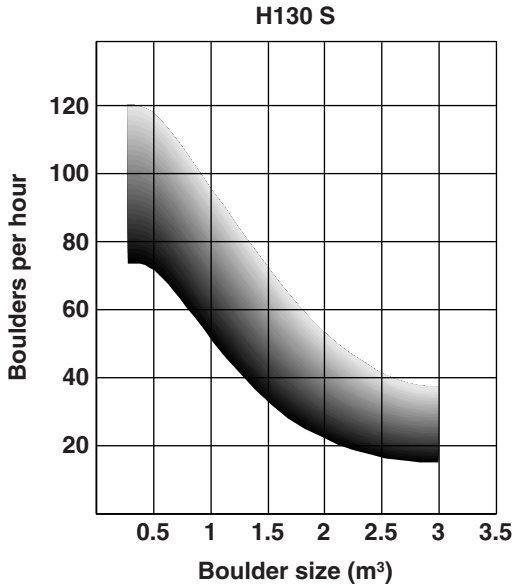

**SOFT ROCK**

**HARD ROCK**

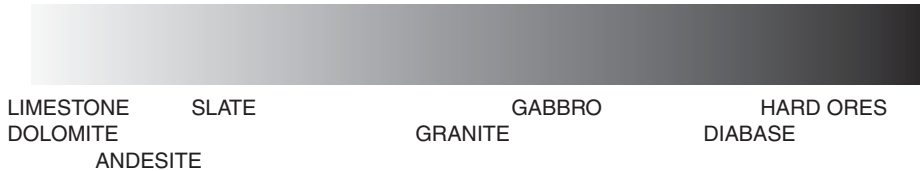

## MOBILE SCRAP AND DEMOLITION SHEARS

C Series Shears incorporate a bolt-on piercing tip — a key feature for enhancing up time for shears.

- Changeable with common hand tools.
- Dual-sided protecting the moving jaw on both sides.
- Fully reversible tip and blades.

Cat Mobile Scrap and Demolition Shears are available in six sizes and feature:

- Straight lower, apex upper jaw design.
- 360 degree bidirectional rotation system.
- Adjustable hub allows users to maintain tolerances between the jaws in the field.
- High force to weight ratio.
- Long wearing alloy steel blades.
- Cutting edges mounted on the side of the shear jaws and are visible to the operator.
- Shears can be mounted on boom or stick.

### Applications:

Cat Mobile Scrap and Demolition Shears are designed to cut and reduce the size of metal items commonly found in scrap yards, buildings, and other structures.

The profiles on the next page approximate shear cutting capacity. The cutting capacities listed on the next page were achieved by cutting the specified steel profiles with a shear operating pressure at 35 000 kPa (5075 psi) and knives in slightly used condition. Lower operating pressures, dull knife edges, and harder steels will obviously reduce cutting capability.

### Guarding Recommendation

Shears used in hazardous applications like demolition, and scrap and material handling can create a need for special operator guarding due to flying or falling objects. When using a shear, additional protective devices such as a front screen, Falling Object Guarding System (FOGS, includes top and front guarding), thick polycarbonate windshields or a combination of these is recommended by Caterpillar. Contact your Cat dealer for operator guarding options on your machine.

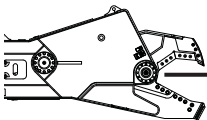
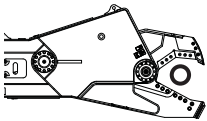
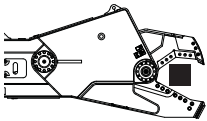
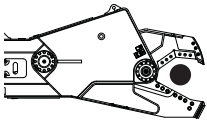
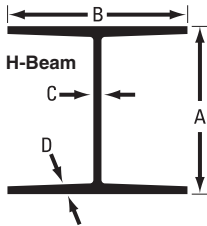
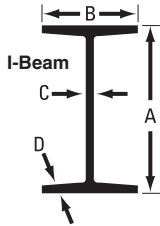

Model		S385C	S365C	S340B	S325B	S320B	S305
<b>I-Beams</b>							
<b>A</b> Height	mm (in)	635 (25)	612 (24.1)	457.2 (18)	407 (16)	358 (14.1)	207 (8.1)
<b>B</b> Flange width	mm (in)	329 (13)	229 (9)	191 (7.5)	178 (7.0)	172 (6.8)	112 (4.4)
<b>C</b> Web thickness	mm (in)	18 (0.7)	12 (0.5)	9.017 (0.4)	7.7 (0.3)	7.8 (0.3)	5.8 (0.2)
<b>D</b> Flange thickness	mm (in)	31 (1.2)	20 (0.8)	15.24 (0.6)	12.7 (0.5)	12.7 (0.5)	8.4 (0.3)
Weight	kg/m (ft-lb)	241 (162)	125 (84)	74.4 (50)	59.5 (40)	56.5 (38)	22.3 (15)
<b>Wide I-Beams</b>				<b>H-Beams</b>			
<b>A</b> Height	mm (in)	476 (18.7)	472 (18.6)	311 (12.2)	256 (10.1)	204 (8)	107 (4.2)
<b>B</b> Flange width	mm (in)	284 (11.2)	284 (11.2)	306 (12)	255 (10)	206 (8.1)	103 (4.1)
<b>C</b> Web thickness	mm (in)	24 (0.9)	13 (0.5)	10.9 (0.4)	9.4 (0.4)	7.9 (0.3)	7.11 (0.3)
<b>D</b> Flange thickness	mm (in)	15 (0.6)	22 (0.9)	10.9 (0.4)	9.4 (0.4)	7.9 (0.3)	8.8 (0.3)
Weight	kg/m (ft-lb)	158 (106)	144 (97)	107 (71.9)	80 (53.8)	52 (34.9)	19.4 (13)

<b>Round</b>							
Diameter	mm (in)	125 (5)	120 (4.75)	115 (4.5)	100 (4)	90 (3.5)	50.8 (2)

<b>Square</b>							
Width	mm (in)	120 (4.75)	100 (4)	90 (3.5)	90 (3.5)	65 (2.5)	40 (1.5)

<b>Pipe (Schedule 40)</b>							
Diameter	mm (in)	508 (20)	458 (18)	406 (16)	356 (14)	325 (12.8)	220 (8.6)
Wall thickness	mm (in)	15 (0.6)	15 (0.6)	13 (0.5)	11 (0.4)	10 (0.4)	8 (0.3)

<b>Piercing</b>							
Thickness	mm (in)	33 (1.38)	27 (1.25)	22 (0.88)	19 (0.75)	16 (0.63)	10 (0.38)

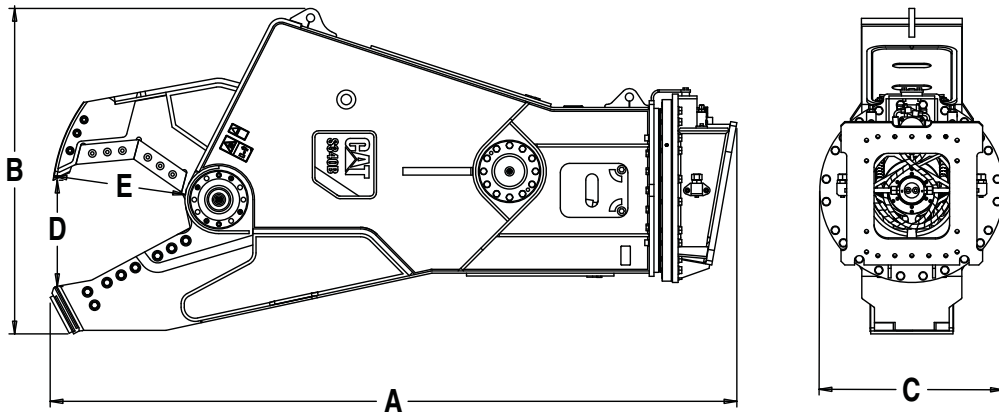

Model		S385C	S365C	S340B	S325B	S320B	S305
Weight*, boom-mount	kg (lb)	8320 (18,345)	6870 (15,145)	4695 (10,351)	3390 (7474)	2570 (5666)	608 (1340)
Weight*, stick-mount	kg (lb)	7975 (17,580)	6700 (14,770)	4386 (9670)	2996 (6604)	2165 (4774)	580 (1280)
<b>Dimensions</b>							
<b>A</b> Length	mm (in)	4260 (168)	3840 (151)	3638 (143)	3177 (125)	2792 (110)	1709 (67.3)
<b>B</b> Height	mm (in)	2121 (84)	1900 (75)	1723 (68)	1525 (60)	1340 (53)	660 (26)
<b>C</b> Width	mm (in)	1400 (55)	1180 (46)	975 (38)	792 (31)	792 (31)	390 (15)
Jaw width, fixed	mm (in)	466 (18)	466 (18)	396 (16)	342 (13)	304 (12)	230 (9)
Jaw width, moving	mm (in)	150 (6)	150 (6)	120 (5)	100 (4)	90 (3)	60 (2)
<b>D</b> Jaw opening	mm (in)	879 (35)	845 (33)	563 (22)	528 (21)	409 (16)	240 (9.4)
<b>E</b> Jaw Depth	mm (in)	903 (35)	840 (33)	703 (28)	571 (22)	459 (18)	290 (11.4)

\*Weight includes mounting bracket.



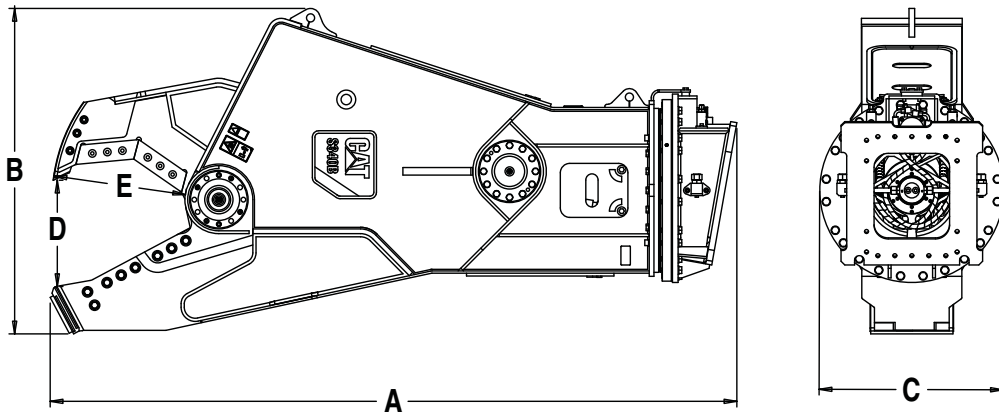

<b>Model</b>		<b>S385C</b>	<b>S365C</b>	<b>S340B</b>	<b>S325B</b>	<b>S320B</b>	<b>S305</b>
<b>Shear Forces*</b>							
Throat**	<b>kN</b> (st)	12 509 (1405)	10 342 (1162)	6818 (766)	5562 (625)	3706 (417)	1812 (204)
Apex	<b>kN</b> (st)	4413 (496)	3576 (402)	2751 (309)	2221 (250)	1583 (178)	653 (73)
Tip	<b>kN</b> (st)	2455 (276)	1975 (222)	1558 (175)	1274 (143)	892 (100)	385 (43)
Shear arm torque	<b>kN·m</b> (ft·lb)	2779 (2,050,000)	2083 (1,536,000)	1374 (1,013,700)	931 (686,900)	534 (394,100)	140 (103,600)
Cycle time, open	<b>seconds</b>	5	5	5	5	4	3.5
Cycle time, close	<b>seconds</b>	3	3	3	3	3	2.5
<b>Hydraulic Requirements, Cutting Circuit</b>							
Maximum relief pressure	<b>kPa</b> (psi)	35 000 (5075)	35 000 (5075)	35 000 (5075)	35 000 (5075)	35 000 (5075)	25 000 (3625)
Maximum recommended flow	<b>L/min</b> (gpm)	690 (182)	530 (140)	300 (79)	200 (53)	150 (40)	60 (16)
<b>Hydraulic Requirements, Rotation Circuit</b>							
Maximum relief pressure	<b>kPa</b> (psi)	14 000 (2030)	14 000 (2030)	14 000 (2030)	14 000 (2030)	14 000 (2030)	10 000 (1450)
Maximum recommended flow	<b>L/min</b> (gpm)	80 (21)	80 (21)	40 (11)	40 (11)	40* (11*)	20 (5)

\*Calculated with a maximum operating pressure of 35 MPa (5075 psi).

\*\*Measured at innermost cutting point of the jaw.

**Matching Guide**

Pin-On matches are shown below.

Matches are based on counterweight and grouser width on standard machines.

Wheeled excavator matches are calculated with all four stabilizers down.

**Stick-Mount**

Cat Excavator	Boom	Stick		S385C	S365C	S340B	S325B	S320B	S305
		m	(ft/in)						
<b>390D L</b>	GP	5.5	(18'1")		X				
		4.4	(14'5")	X	X				
		3.4	(11'2")	X	X				
		3.7	(12'2")	X	X				
		2.92	(9'7")	X	X				
<b>374D L</b>	Reach	4.15	(13'7")		X				
		3.6	(11'10")		X				
		2.84	(9'4")		X				
<b>345D L – VG</b>	Reach	3.9	(12'10")			X			
		3.35	(11'0")			X			
<b>345D – FIX</b>	Reach	3.9	(12'10")			X	X		
		3.3	(11'0")			X	X		
<b>345C – DEM</b>		28	(91'9")					X	
		26	(85'0")					X	
<b>336D L/330D L</b>	Reach	3.9	(12'10")				X	X	
		3.2	(10'6")				X	X	
<b>329D L/325D L</b>	Reach	3.2	(10'6")				X	X	
							X	X	
		2.65	(8'8")				X	X	
<b>328D LCR</b>	Reach	3.76	(12'4")					X	
		3.2	(10'6")				X	X	
		2.65	(8'8")				X	X	
<b>324D L</b>	Reach	3.6	(11'10")					X	
		2.95	(9'8")				X	X	
		2.5	(8'2")				X	X	
<b>321D LCR</b>	Reach	2.92	(9'6")					X	
		2.5	(8'2")					X	
<b>320D L</b>	Reach	2.92	(9'6")					X	
		2.5	(8'2")					X	
<b>320D LRR</b>	Reach	2.92	(9'6")					X	
		2.5	(8'2")					X	
	Reach-HD	2.92	(9'6")					X	
		2.5	(8'3")					X	
<b>319D L</b>	Reach	2.7	(8'10")					X	
		2.25	(7'5")					X	
<b>M322D</b>	One-Piece	2.5	(8'2")					X	
		2.2	(7'3")					X	
<b>M318D</b>	One-Piece	2.8	(9'2")					X	
		2.5	(8'2")					X	
		2.2	(7'3")					X	
<b>M316D</b>	One-Piece	2.4	(7'10")					X	
		2.1	(6'11")					X	
<b>M315D</b>	One-Piece	2.4	(7'10")					X	
		2.1	(6'11")					X	
<b>308D CR</b>	One-Piece	2.2	(7'3")						X
		1.7	(5'6")						X
<b>307D</b>	One-Piece	2.2	(7'3")						X
		1.7	(5'6")						X

Pin-on matches are shown above. Please reference bulletin GEJH0016 for matching information when utilizing a pin-grabber or dedicated coupler.

DEM = Demolition machine

VG = Variable wide gauge undercarriage

FIX = Fixed undercarriage

**Matching Guide**

Matches are based on counterweight and grouser width on standard machines.  
Wheeled excavator matches are calculated with all four stabilizers down.

**Boom-Mount**

Cat Excavator	Boom	S385C	S365C	S340B	S325B	S320B	S305
<b>365C L</b>	Reach	X					
<b>345D L – VG</b>	Reach	X	X				
<b>345D – FIX</b>	Reach	X	X				
<b>336D L/330D L</b>	Reach		X	X			
<b>329D L/325D L</b>	Reach			X			
<b>328D L CR</b>	Reach			X			
<b>324D L</b>	Reach			X			
<b>321D L CR</b>	Reach				X		
<b>320D L</b>	Reach				X		
<b>320D LRR</b>	Reach				X		
	Reach-HD				X		
<b>319D L</b>	Reach				X	X	
<b>315D L</b>	Reach				X	X	
<b>314D CR</b>	Reach					X	
<b>312D L</b>	Reach					X	
<b>311D LRR</b>	Reach					X	
<b>M322D</b>	One-Piece			X			
<b>M318D</b>	One-Piece			X	X		
<b>M316D</b>	One-Piece			X	X		
<b>M315D</b>	One-Piece				X	X	
<b>M313D</b>	One-Piece				X	X	
<b>305D CR</b>	One-Piece						X
<b>304D CR</b>	One-Piece						X
<b>303.5D CR</b>	One-Piece						X

**Cat S305 is a match for all Skid Steer Loaders 236B2 and larger and all Multi-Terrain Loaders.**

Please reference bulletin GEJH0016 for matching information when utilizing a pin-grabber or dedicated coupler.

VG = Variable wide gauge undercarriage

FIX = Fixed undercarriage

## MULTI-PROCESSORS

### Features:

- **Wide selection** of interchangeable jaws.
- **Lifting eye placement** and adjustable stop bolts allow quick jaw changes.
- **Single, large diameter** cross mounted cylinder provides exceptional cutting and crushing force.
- **Jaws are manufactured** of high quality tool steel with outstanding tensile strength.
- **Non impact** tools that work at a relatively low noise level.

### Applications:

The Cat Multi-Processors can be used to accomplish most tasks on a demolition job. One common housing with a wide selection of interchangeable jaws allows the tool to cut, crush or pulverize the toughest of materials. Highly reinforced concrete, structural steel beams, pipes, cable, steel plate and storage tanks.

## Matching Guide

### Stick Mounted/Reach Boom

Multi-Processors Model	Cat Excavator
<b>MP15</b>	315C, 318C, 319C, 319D 320C, 320D, 321C CR, 320D RR, 323D, 324D M315C, M316C, M318C, M322C, M315D, M316D, M318D, M322D 325C UHD, 330C UHD, 345C UHD, 365C UHD, 385C UHD
<b>MP20</b>	320C, 320D, 320D RR, 323D, 324D, 325D, 330D 325C UHD, 330C UHD, 345C UHD, 365C UHD, 385C UHD
<b>MP30</b>	330D 345C 365C UHD, 385C UHD
<b>MP40</b>	365C, 385C

These matches are for general reference purpose for Cat machines only.

Please always check the stability of the machine-tool configuration.

The stability depends on application, tool used and your machine configuration. For questions please contact your Cat dealer.

When choosing between various multi-processor models that can be installed onto the same machine configuration, consider work tool application, productivity requirements, and durability.

## CAT MULTI-PROCESSOR INTERCHANGEABLE JAWS

### Concrete Cutter Jaws (CC)

- For precise demolition/cutting of heavily reinforced concrete structures.
- Cuts structural steel and pipe.
- Equipped with replaceable concrete crusher teeth and reversible steel cutting knives.

### Shear Jaws (S)

- For demolition of steel structures.
- Cuts angle and channel iron, beams, pipe, rebar, cable and tires.
- Knives are reversible.

### Tank Shear Jaws (TS)

- Quickly cuts steel plate on barges, railway cars, grain, water, oil, and fuel tanks. Dual knives on the moving and static jaws produce smooth, straight edges.
- All knives are reversible.
- Available for MP20 and MP30 only.

### Crusher Jaws (CR)

- For demolition of moderately reinforced concrete structures. Capable of crushing concrete and cutting rebar.
- Replaceable crusher teeth and reversible knives.

### Primary Pulverizer Jaws (PP)

- Combines capability to demolish and recycle moderately reinforced concrete structures. Pulverizes concrete, cuts rebar and separates rebar from concrete. (Not available for MP40.)
- Replaceable crusher teeth and reversible knives.

### Secondary Pulverizer Jaws (PS)

- Recycles demolished concrete by pulverizing concrete, separating concrete and rebar, and cutting rebar as needed.

**All jaw sets can be interchanged quickly with the lifting eyes and the adjustable stop-bolts on jaws and body.**

**Guarding Recommendation**

Multi-Processors used in hazardous applications like demolition, and scrap and material handling can create a need for special operator guarding due to flying or falling objects. When using a Multi-Processor, additional protective devices such as a front screen, Falling Object Guarding System (FOGS, includes top and front guarding), thick polycarbonate windshields or a combination of these is recommended by Caterpillar. Contact your Cat dealer for operator guarding options on your machine.

**Specifications** (All dimensions are approximate.)

<b>Model</b>	<b>MP15</b>		<b>MP20</b>		<b>MP30</b>		<b>MP40</b>	
Weight total — housing, jaw and bracket	2020 kg	<b>4450 lb</b>	2660 kg	<b>5864 lb</b>	3850 kg	<b>8190 lb</b>	6370 kg	<b>14,045 lb</b>
Weight of the jaw	640 kg	<b>1410 lb</b>	930 kg	<b>2050 lb</b>	1260 kg	<b>2780 lb</b>	2230 kg	<b>4915 lb</b>
Dimensions:								
Length	2200 mm	<b>86.6"</b>	2400 mm	<b>94.5"</b>	2800 mm	<b>110.2"</b>	3500 mm	<b>137.8"</b>
Height	1510 mm	<b>59.4"</b>	1750 mm	<b>68.8"</b>	1980 mm	<b>78"</b>	2340 mm	<b>92.1"</b>
Width	800 mm	<b>31.5"</b>	800 mm	<b>31.5"</b>	1010 mm	<b>39.8"</b>	1180 mm	<b>46.5"</b>
Jaw width (fixed)	300 mm	<b>11.8"</b>	360 mm	<b>14.2"</b>	380 mm	<b>15"</b>	460 mm	<b>18.1"</b>
Jaw width (moving)	100 mm	<b>3.9"</b>	130 mm	<b>5.1"</b>	130 mm	<b>5.1"</b>	160 mm	<b>6.3"</b>
Jaw opening	670 mm	<b>26.4"</b>	820 mm	<b>32.2"</b>	975 mm	<b>38.4"</b>	1280 mm	<b>50.4"</b>
Jaw depth	670 mm	<b>26.4"</b>	790 mm	<b>31.1"</b>	890 mm	<b>35"</b>	1100 mm	<b>43.3"</b>
Cutter length	400 mm	<b>15.8"</b>	460 mm	<b>18.1"</b>	520 mm	<b>20.5"</b>	600 mm	<b>23.6"</b>
Maximum crushing/shear force:								
Tooth — jaw tip	700 kN	<b>79 st</b>	950 kN	<b>107 st</b>	1250 kN	<b>140 st</b>	1500 kN	<b>168 st</b>
Front cutter tip	1000 kN	<b>112 st</b>	1400 kN	<b>157 st</b>	1850 kN	<b>208 st</b>	2200 kN	<b>247 st</b>
Primary blade center	2200 kN	<b>247 st</b>	3000 kN	<b>337 st</b>	4100 kN	<b>460 st</b>	4400 kN	<b>494 st</b>
Maximum oil flow:								
Hydraulic cylinder	150 L/min	<b>40 gpm</b>	200 L/min	<b>53 gpm</b>	300 L/min	<b>79 gpm</b>	400 L/min	<b>106 gpm</b>
Cycle time (open, close, open)		<b>5 sec</b>		<b>6 sec</b>		<b>6.5 sec</b>		<b>7.5 sec</b>
Rotation	40 L/min	<b>11 gpm</b>	40 L/min	<b>11 gpm</b>	40 L/min	<b>11 gpm</b>	80 L/min	<b>22 gpm</b>
Maximum working pressure:								
Hydraulic cylinder	35 000 kPa	<b>5075 psi</b>	35 000 kPa	<b>5075 psi</b>	35 000 kPa	<b>5075 psi</b>	35 000 kPa	<b>5075 psi</b>
Rotation	14 000 kPa	<b>2030 psi</b>	14 000 kPa	<b>2030 psi</b>	14 000 kPa	<b>2030 psi</b>	14 000 kPa	<b>2030 psi</b>

**Specifications** (All dimensions are approximate.)

<b>Model</b>	<b>MP15</b>		<b>MP20</b>		<b>MP30</b>		<b>MP40</b>	
Weight total — housing, jaw and bracket	1950 kg	<b>4300 lb</b>	2570 kg	<b>5665 lb</b>	3890 kg	<b>8575 lb</b>	6430 kg	<b>14,175 lb</b>
Weight of the jaw	570 kg	<b>1255 lb</b>	840 kg	<b>1850 lb</b>	1300 kg	<b>2865 lb</b>	2200 kg	<b>4850 lb</b>
Dimensions:								
Length	2100 mm	<b>82.7"</b>	2250 mm	<b>88.6"</b>	2700 mm	<b>106.3"</b>	3400 mm	<b>133.9"</b>
Height	1310 mm	<b>51.6"</b>	1510 mm	<b>59.4"</b>	1680 mm	<b>66.1"</b>	1980 mm	<b>78"</b>
Width	800 mm	<b>31.5"</b>	800 mm	<b>31.5"</b>	1010 mm	<b>39.8"</b>	1180 mm	<b>46.5"</b>
Jaw width (fixed)	300 mm	<b>11.8"</b>	320 mm	<b>12.6"</b>	370 mm	<b>14.6"</b>	460 mm	<b>18.1"</b>
Jaw width (moving)	80 mm	<b>3.1"</b>	100 mm	<b>3.9"</b>	120 mm	<b>4.7"</b>	150 mm	<b>5.9"</b>
Jaw opening	390 mm	<b>15.4"</b>	420 mm	<b>16.5"</b>	470 mm	<b>18.5"</b>	630 mm	<b>24.8"</b>
Jaw depth	480 mm	<b>18.9"</b>	580 mm	<b>22.8"</b>	710 mm	<b>28"</b>	880 mm	<b>34.6"</b>
Cutter length	400 mm	<b>15.7"</b>	520 mm	<b>20.5"</b>	600 mm	<b>23.6"</b>	760 mm	<b>29.9"</b>
Maximum shear force:								
At tip	900 kN	<b>101 st</b>	1200 kN	<b>135 st</b>	1600 kN	<b>180 st</b>	1900 kN	<b>213 st</b>
Primary blade center	2100 kN	<b>236 st</b>	2900 kN	<b>326 st</b>	3750 kN	<b>421 st</b>	4750 kN	<b>534 st</b>
At throat	4200 kN	<b>472 st</b>	5800 kN	<b>652 st</b>	7100 kN	<b>798 st</b>	8950 kN	<b>1006 st</b>
Maximum oil flow:								
Hydraulic cylinder	150 L/min	<b>40 gpm</b>	200 L/min	<b>53 gpm</b>	300 L/min	<b>79 gpm</b>	400 L/min	<b>106 gpm</b>
Cycle time (open, close, open)		<b>5 sec</b>		<b>6 sec</b>		<b>6.5 sec</b>		<b>7.5 sec</b>
Rotation	40 L/min	<b>11 gpm</b>	40 L/min	<b>11 gpm</b>	40 L/min	<b>11 gpm</b>	80 L/min	<b>22 gpm</b>
Maximum working pressure:								
Hydraulic cylinder	35 000 kPa	<b>5075 psi</b>	35 000 kPa	<b>5075 psi</b>	35 000 kPa	<b>5075 psi</b>	35 000 kPa	<b>5075 psi</b>
Rotation	14 000 kPa	<b>2030 psi</b>	14 000 kPa	<b>2030 psi</b>	14 000 kPa	<b>2030 psi</b>	14 000 kPa	<b>2030 psi</b>

**Specifications** (All dimensions are approximate.)

<b>Model</b>	<b>MP20</b>		<b>MP30</b>	
Weight total — housing, jaw and bracket	2740 kg	<b>6040 lb</b>	4380 kg	<b>9655 lb</b>
Weight of the jaw	1010 kg	<b>2225 lb</b>	1790 kg	<b>3945 lb</b>
Dimensions:				
Length	2400 mm	<b>94.5"</b>	2800 mm	<b>110.2"</b>
Height	1750 mm	<b>68.9"</b>	2100 mm	<b>82.7"</b>
Width	800 mm	<b>31.5"</b>	1180 mm	<b>46.5"</b>
Jaw width (fixed)	290 mm	<b>11.4"</b>	340 mm	<b>13.4"</b>
Jaw width (moving)	120 mm	<b>4.7"</b>	150 mm	<b>5.9"</b>
Jaw opening	440 mm	<b>17.3"</b>	510 mm	<b>20.1"</b>
Jaw depth	460 mm	<b>18.1"</b>	580 mm	<b>22.8"</b>
Cutter length	460 mm	<b>18.1"</b>	580 mm	<b>22.8"</b>
Maximum shear force:				
At tip	1400 kN	<b>157 st</b>	1900 kN	<b>213 st</b>
At jaw center	2200 kN	<b>247 st</b>	4000 kN	<b>449 st</b>
At throat	4400 kN	<b>494 st</b>	6350 kN	<b>714 st</b>
Cutting capacity plate steel	25 mm	<b>1"</b>	30 mm	<b>1.2"</b>
Maximum oil flow:				
Hydraulic cylinder	200 L/min	<b>53 gpm</b>	200 L/min	<b>53 gpm</b>
Cycle time (open, close, open)		<b>6 sec</b>		<b>6.5 sec</b>
Rotation	40 L/min	<b>11 gpm</b>	40 L/min	<b>11 gpm</b>
Maximum working pressure:				
Hydraulic cylinder	35 000 kPa	<b>5075 psi</b>	35 000 kPa	<b>5075 psi</b>
Rotation	14 000 kPa	<b>2030 psi</b>	14 000 kPa	<b>2030 psi</b>

**Specifications** (All dimensions are approximate.)

<b>Model</b>	<b>MP15</b>		<b>MP20</b>		<b>MP30</b>		<b>MP40</b>	
Weight total — housing, jaw and bracket	2010 kg	<b>4430 lb</b>	2660 kg	<b>5865 lb</b>	3860 kg	<b>8510 lb</b>	6370 kg	<b>14,045 lb</b>
Weight of the jaw	630 kg	<b>1390 lb</b>	930 kg	<b>2050 lb</b>	1270 kg	<b>2800 lb</b>	2230 kg	<b>4915 lb</b>
Dimensions:								
Length	2200 mm	<b>86.6"</b>	2350 mm	<b>92.5"</b>	2770 mm	<b>102"</b>	3500 mm	<b>137.8"</b>
Height	1310 mm	<b>51.6"</b>	1750 mm	<b>68.9"</b>	1980 mm	<b>78"</b>	2380 mm	<b>93.7"</b>
Width	800 mm	<b>31.5"</b>	800 mm	<b>31.5"</b>	1010 mm	<b>39.8"</b>	1180 mm	<b>46.5"</b>
Jaw width (fixed)	300 mm	<b>11.8"</b>	360 mm	<b>14.2"</b>	380 mm	<b>15"</b>	460 mm	<b>18.1"</b>
Jaw width (moving)	100 mm	<b>3.9"</b>	130 mm	<b>5.1"</b>	130 mm	<b>5.1"</b>	160 mm	<b>6.3"</b>
Jaw opening	710 mm	<b>28"</b>	850 mm	<b>33.5"</b>	1050 mm	<b>41.3"</b>	1320 mm	<b>52"</b>
Jaw depth	700 mm	<b>27.6"</b>	770 mm	<b>30.3"</b>	920 mm	<b>36.2"</b>	1100 mm	<b>43.3"</b>
Cutter length	200 mm	<b>7.9"</b>	260 mm	<b>10.2"</b>	260 mm	<b>10.2"</b>	250 mm	<b>9.8"</b>
Maximum crushing/shear force:								
Tooth — jaw tip	700 kN	<b>79 st</b>	950 kN	<b>107 st</b>	1250 kN	<b>140 st</b>	1500 kN	<b>168 st</b>
At 2 <sup>nd</sup> tooth	950 kN	<b>107 st</b>	1350 kN	<b>152 st</b>	1750 kN	<b>197 st</b>	2200 kN	<b>247 st</b>
Primary blade center	2100 kN	<b>236 st</b>	2900 kN	<b>326 st</b>	3800 kN	<b>427 st</b>	4650 kN	<b>523 st</b>
Maximum oil flow:								
Hydraulic cylinder	150 L/min	<b>40 gpm</b>	200 L/min	<b>53 gpm</b>	300 L/min	<b>79 gpm</b>	400 L/min	<b>106 gpm</b>
Cycle time (open, close, open)	<b>5 sec</b>		<b>6 sec</b>		<b>6.5 sec</b>		<b>7.5 sec</b>	
Rotation	40 L/min	<b>11 gpm</b>	40 L/min	<b>11 gpm</b>	40 L/min	<b>11 gpm</b>	80 L/min	<b>22 gpm</b>
Maximum working pressure:								
Hydraulic cylinder	35 000 kPa	<b>5075 psi</b>	35 000 kPa	<b>5075 psi</b>	35 000 kPa	<b>5075 psi</b>	35 000 kPa	<b>5075 psi</b>
Rotation	14 000 kPa	<b>2030 psi</b>	14 000 kPa	<b>2030 psi</b>	14 000 kPa	<b>2030 psi</b>	14 000 kPa	<b>2030 psi</b>



**Specifications** (All dimensions are approximate.)

<b>Model</b>	<b>MP15</b>		<b>MP20</b>		<b>MP30</b>	
Weight total — housing, jaw and bracket	2200 kg	<b>4895 lb</b>	2900 kg	<b>6390 lb</b>	4180 kg	<b>9215 lb</b>
Weight of the jaw	840 kg	<b>1850 lb</b>	1170 kg	<b>2580 lb</b>	1590 kg	<b>3505 lb</b>
Dimensions:						
Length	2220 mm	<b>87.4"</b>	2325 mm	<b>91.5"</b>	2800 mm	<b>110.2"</b>
Height	1590 mm	<b>62.6"</b>	1775 mm	<b>69.9"</b>	1980 mm	<b>78"</b>
Width	800 mm	<b>31.5"</b>	800 mm	<b>31.5"</b>	1010 mm	<b>39.8"</b>
Jaw width (fixed)	480 mm	<b>18.9"</b>	540 mm	<b>21.3"</b>	610 mm	<b>24"</b>
Jaw width (moving)	280 mm	<b>11"</b>	340 mm	<b>13.4"</b>	370 mm	<b>14.6"</b>
Jaw opening	700 mm	<b>27.6"</b>	800 mm	<b>31.5"</b>	960 mm	<b>37.8"</b>
Jaw depth	700 mm	<b>27.6"</b>	800 mm	<b>31.5"</b>	940 mm	<b>37"</b>
Cutter length	200 mm	<b>7.9"</b>	200 mm	<b>7.9"</b>	250 mm	<b>9.8"</b>
Maximum crushing/shear force:						
Tooth — jaw tip	650 kN	<b>73 st</b>	950 kN	<b>107 st</b>	1250 kN	<b>140 st</b>
At 2 <sup>nd</sup> tooth	900 kN	<b>101 st</b>	1300 kN	<b>146 st</b>	1550 kN	<b>174 st</b>
Primary blade center	2100 kN	<b>236 st</b>	2750 kN	<b>309 st</b>	3950 kN	<b>444 st</b>
Maximum oil flow:						
Hydraulic cylinder	150 L/min	<b>40 gpm</b>	200 L/min	<b>53 gpm</b>	300 L/min	<b>79 gpm</b>
Cycle time (open, close, open)		<b>5 sec</b>		<b>6 sec</b>		<b>6.5 sec</b>
Rotation	40 L/min	<b>11 gpm</b>	40 L/min	<b>11 gpm</b>	40 L/min	<b>11 gpm</b>
Maximum working pressure:						
Hydraulic cylinder	35 000 kPa	<b>5075 psi</b>	35 000 kPa	<b>5075 psi</b>	35 000 kPa	<b>5075 psi</b>
Rotation	14 000 kPa	<b>2030 psi</b>	14 000 kPa	<b>2030 psi</b>	14 000 kPa	<b>2030 psi</b>

**Specifications** (All dimensions are approximate.)

<b>Model</b>	<b>MP15</b>		<b>MP20</b>		<b>MP30</b>		<b>MP40</b>	
Weight total — housing, jaw and bracket	2100 kg	<b>4630 lb</b>	2770 kg	<b>6105 lb</b>	4080 kg	<b>8995 lb</b>	6730 kg	<b>14,835 lb</b>
Weight of the jaw	720 kg	<b>1585 lb</b>	1040 kg	<b>2290 lb</b>	1490 kg	<b>3285 lb</b>	2590 kg	<b>5710 lb</b>
Dimensions:								
Length	2250 mm	<b>88.6"</b>	2450 mm	<b>96.5"</b>	2950 mm	<b>116.1"</b>	3650 mm	<b>143.7"</b>
Height	1650 mm	<b>65"</b>	1900 mm	<b>74.8"</b>	2200 mm	<b>86.6"</b>	2550 mm	<b>100.4"</b>
Width	800 mm	<b>31.5"</b>	800 mm	<b>31.5"</b>	1010 mm	<b>39.8"</b>	1180 mm	<b>46.5"</b>
Jaw width (fixed)	440 mm	<b>17.3"</b>	500 mm	<b>19.7"</b>	580 mm	<b>22.8"</b>	700 mm	<b>27.6"</b>
Jaw width (moving)	310 mm	<b>12.2"</b>	360 mm	<b>14.2"</b>	420 mm	<b>16.5"</b>	480 mm	<b>18.9"</b>
Jaw opening	730 mm	<b>28.7"</b>	890 mm	<b>35"</b>	1100 mm	<b>43.3"</b>	1400 mm	<b>55.1"</b>
Jaw depth	670 mm	<b>26.4"</b>	800 mm	<b>31.5"</b>	970 mm	<b>38.2"</b>	1170 mm	<b>46"</b>
Cutter length	200 mm	<b>7.9"</b>	200 mm	<b>7.9"</b>	200 mm	<b>7.9"</b>	250 mm	<b>9.8"</b>
Maximum crushing/shear force:								
Tooth — jaw tip	750 kN	<b>84 st</b>	1000 kN	<b>112 st</b>	1250 kN	<b>141 st</b>	1500 kN	<b>168 st</b>
At 2 <sup>nd</sup> tooth	1000 kN	<b>112 st</b>	1300 kN	<b>146 st</b>	1550 kN	<b>174 st</b>	1900 kN	<b>213 st</b>
Primary blade center	2200 kN	<b>247 st</b>	3000 kN	<b>337 st</b>	4800 kN	<b>539 st</b>	5500 kN	<b>618 st</b>
Maximum oil flow:								
Hydraulic cylinder	150 L/min	<b>40 gpm</b>	200 L/min	<b>53 gpm</b>	300 L/min	<b>79 gpm</b>	400 L/min	<b>106 gpm</b>
Cycle time (open, close, open)	<b>5 sec</b>		<b>6 sec</b>		<b>6.5 sec</b>		<b>7.5 sec</b>	
Rotation	40 L/min	<b>11 gpm</b>	40 L/min	<b>11 gpm</b>	40 L/min	<b>11 gpm</b>	80 L/min	<b>22 gpm</b>
Maximum working pressure:								
Hydraulic cylinder	35 000 kPa	<b>5075 psi</b>	35 000 kPa	<b>5075 psi</b>	35 000 kPa	<b>5075 psi</b>	35 000 kPa	<b>5075 psi</b>
Rotation	14 000 kPa	<b>2030 psi</b>	14 000 kPa	<b>2030 psi</b>	14 000 kPa	<b>2030 psi</b>	14 000 kPa	<b>2030 psi</b>

**Cutting Capacity**

<b>Model</b>	<b>MP15</b>		<b>MP20</b>		<b>MP30</b>		<b>MP40</b>	
Narrow I-beams:								
Height	300 mm	<b>11.8"</b>	400 mm	<b>15.7"</b>	500 mm	<b>19.7"</b>	600 mm	<b>23.6"</b>
Flange width	150 mm	<b>5.9"</b>	180 mm	<b>7.1"</b>	200 mm	<b>7.9"</b>	600 mm	<b>8.7"</b>
Flange thickness	10.7 mm	<b>0.42"</b>	13.5 mm	<b>0.53"</b>	16 mm	<b>0.63"</b>	19 mm	<b>0.75"</b>
Web thickness	7.1 mm	<b>0.28"</b>	8.6 mm	<b>0.34"</b>	10.2 mm	<b>0.4"</b>	12 mm	<b>0.47"</b>
Wide I-beams:								
Height	190 mm	<b>7.5"</b>	250 mm	<b>9.8"</b>	310 mm	<b>12.2"</b>	390 mm	<b>15.4"</b>
Flange width	200 mm	<b>7.9"</b>	260 mm	<b>10.2"</b>	300 mm	<b>11.8"</b>	300 mm	<b>11.8"</b>
Flange thickness	10 mm	<b>0.39"</b>	12.5 mm	<b>0.49"</b>	15.5 mm	<b>0.61"</b>	19 mm	<b>0.75"</b>
Web thickness	6.5 mm	<b>0.26"</b>	7.5 mm	<b>0.3"</b>	9 mm	<b>0.35"</b>	11 mm	<b>0.43"</b>
Solid-round	65 mm	<b>2.6"</b>	80 mm	<b>3.3"</b>	90 mm	<b>3.5"</b>	100 mm	<b>3.9"</b>
Solid-square	60 mm	<b>2.4"</b>	70 mm	<b>2.8"</b>	80 mm	<b>3.1"</b>	90 mm	<b>3.5"</b>

The above profiles provide an indication of the shear's cutting capability. The exact cutting dimensions depend on excavator size, the conditions of the cutters and jaws and the tensile strength of the steel.

## CONTRACTOR'S GRAPPLES

### Features:

- Fits multiple linkages simply by changing the pin group.
- Designed with less curve allowing material to flow easily out of the grapple, simplifying material loading and unloading.
- Large wear areas made entirely of AR400 steel.
- Matches the entire range of small, medium and large excavators.
- Two-over-three tines interlock to securely grasp and retain more material when sorting and loading.
- Sized to match Cat machines making them able to better realize the machine's maximum performance; both break out and lift capacity.
- One grapple can be used with or without a coupler with no modifications.

### Applications:

Contractor's Grapples are built to handle demolition of brick and wood structures, land clearing, sorting and loading of rock, scrap, pipe, waste material and demolition debris.

### Guarding Recommendation

Contractor's Grapples used in hazardous applications like demolition, and scrap and material handling can create a need for special operator guarding due to flying or falling objects. When using a Contractor's Grapple, additional protective devices such as a front screen, Falling Object Guarding System (FOGS, includes top and front guarding), thick polycarbonate windshields or a combination of these is recommended by Caterpillar. Contact your Cat dealer for operator guarding options on your machine.

## Matching Guide

### Contractor's Grapples

Model	Cat Excavator
<b>G107B</b>	307 CR
<b>G112B</b>	312C
<b>G115B</b>	315C
<b>G120B</b>	320D 322C 324D 325D
<b>G125B</b>	320D 322C 324D 325D
<b>G130B</b>	320D 322C 324D 325D 330D
<b>G145B</b>	345C
<b>G165B</b>	345C 350 365C
<b>G185B</b>	385C

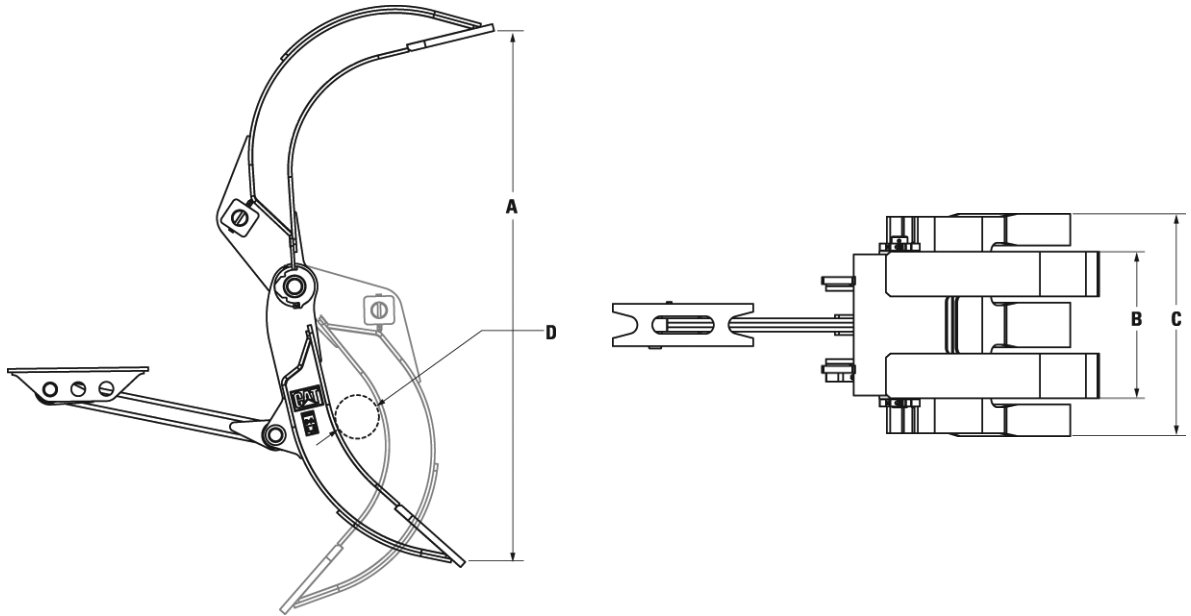

**Specifications** (All dimensions are approximate.)

Model	G107B		G112B		G115B		G120B		G125B	
Weight	360 kg	<b>794 lb</b>	857 kg	<b>1885 lb</b>	1286 kg	<b>2830 lb</b>	1523 kg	<b>3350 lb</b>	1932 kg	<b>4250 lb</b>
<b>A</b> Jaw Opening	1765 mm	<b>69.5"</b>	2195 mm	<b>86.4"</b>	2555 mm	<b>100.6"</b>	2687 mm	<b>105.8"</b>	3128 mm	<b>123.1"</b>
<b>B</b> Upper Tine Width	435 mm	<b>17.1"</b>	550 mm	<b>21.7"</b>	610 mm	<b>24"</b>	617 mm	<b>24.3"</b>	704 mm	<b>27.7"</b>
<b>C</b> Lower Tine Width	735 mm	<b>28.9"</b>	900 mm	<b>35.4"</b>	1020 mm	<b>40.2"</b>	1031 mm	<b>40.6"</b>	1150 mm	<b>45.3"</b>
<b>D</b> Minimum Opening	134 mm	<b>5.3"</b>	186 mm	<b>7.3"</b>	191 mm	<b>7.5"</b>	199 mm	<b>7.8"</b>	245 mm	<b>9.6"</b>
Inner Wrapper Thickness	8 mm	<b>0.3"</b>	12 mm	<b>0.5"</b>	12 mm	<b>0.5"</b>	16 mm	<b>0.6"</b>	16 mm	<b>0.6"</b>
Outer Wrapper Thickness	8 mm	<b>0.3"</b>	12 mm	<b>0.5"</b>	12 mm	<b>0.5"</b>	12 mm	<b>0.5"</b>	16 mm	<b>0.6"</b>
Wear Tip Thickness	12 mm	<b>0.5"</b>	20 mm	<b>0.8"</b>	25 mm	<b>1"</b>	30 mm	<b>1.2"</b>	40 mm	<b>1.6"</b>
Outer Wear Plate Thickness	12 mm	<b>0.5"</b>	16 mm	<b>0.6"</b>	25 mm	<b>1"</b>	20 mm	<b>0.8"</b>	20 mm	<b>0.8"</b>

Model	G130B		G145B		G165B		G185B	
Weight	2332 kg	<b>5130 lb</b>	3050 kg	<b>6724 lb</b>	4055 kg	<b>8940 lb</b>	4800 kg	<b>10,582 lb</b>
<b>A</b> Jaw Opening	3223 mm	<b>126.9"</b>	3433 mm	<b>135.2"</b>	3860 mm	<b>152"</b>	4076 mm	<b>160.5"</b>
<b>B</b> Upper Tine Width	832 mm	<b>32.8"</b>	865 mm	<b>34.1"</b>	937 mm	<b>36.9"</b>	985 mm	<b>38.8"</b>
<b>C</b> Lower Tine Width	1262 mm	<b>49.7"</b>	1335 mm	<b>52.6"</b>	1406 mm	<b>55.4"</b>	1535 mm	<b>60.4"</b>
<b>D</b> Minimum Opening	319 mm	<b>12.6"</b>	271 mm	<b>10.7"</b>	283 mm	<b>11.1"</b>	337 mm	<b>13.3"</b>
Inner Wrapper Thickness	20 mm	<b>0.8"</b>	20 mm	<b>0.8"</b>	25 mm	<b>1"</b>	25 mm	<b>1"</b>
Outer Wrapper Thickness	20 mm	<b>0.8"</b>	20 mm	<b>0.8"</b>	25 mm	<b>1"</b>	25 mm	<b>1"</b>
Wear Tip Thickness	40 mm	<b>1.6"</b>	40 mm	<b>1.6"</b>	40 mm	<b>1.6"</b>	40 mm	<b>1.6"</b>
Outer Wear Plate Thickness	20 mm	<b>0.8"</b>	25 mm	<b>1"</b>	30 mm	<b>1.2"</b>	30 mm	<b>1.2"</b>

**Features:**

- Maintenance free rotator. 360 degrees rotation.
- One fully protected cylinder.
- Standard drill pattern for bolt-on mounting brackets.
- Hydraulic connections positioned at the sides for optimal hydraulic lines protection.
- Standard bolt-on cutting edges.
- High quality bushings with lubrication grooves, hardened pins and dust seals.
- Large inspection covers.
- Two shell types available: Demolition and Recycling.

**Matching Guide**

**Multi-Grapples Europe, Africa, Middle East**

Model	Cat Excavator
<b>G310B</b>	M313D, M315C, M315D, M316C, M316D 311C, 312C, 314C, 315C
<b>G315B</b>	M313D, M315D, M316D, M318C, M318D, M322D 315C, 318C, 319C, 319D, 320C, 320D, 320D RR, 321C CR
<b>G320B</b>	320C, 320D RR, 323D, 324D, 325D

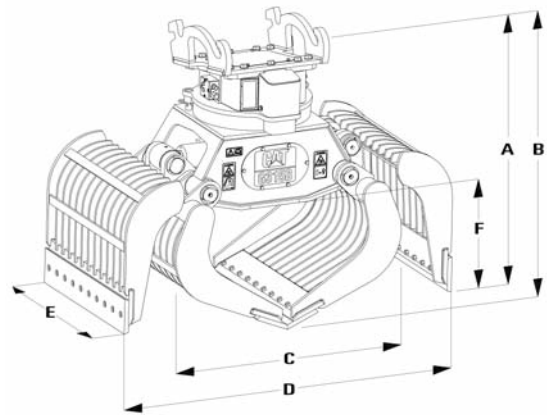

**Specifications** (All dimensions are approximate.)

Model	G310B (Demolition)		G310B (Recycling)		G315B (Demolition)	
Capacity	375 L	0.49 yd <sup>3</sup>	400 L	1.0 yd <sup>3</sup>	550 L	1.3 yd <sup>3</sup>
Weight*	1035 kg	2282 lb	1045 kg	2304 lb	1385 kg	3054 lb
Dimensions:						
<b>A</b> Length	1350 mm	53"	1350 mm	53"	1455 mm	57"
<b>B</b> Length	1440 mm	57"	1440 mm	57"	1550 mm	61"
<b>C</b> Length	1245 mm	49"	1225 mm	48"	1375 mm	54"
<b>D</b> Length	1800 mm	71"	1800 mm	71"	2000 mm	79"
<b>E</b> Width	850 mm	33"	850 mm	33"	1000 mm	39"
<b>F</b> Height	520 mm	20"	520 mm	20"	570 mm	22"
Closing force	36 kN	8100 lb	36 kN	8100 lb	52 kN	11,700 lb
Hydraulic for open/close:						
Maximum pressure	350 bar	5076 psi	350 bar	5076 psi	350 bar	5076 psi
Maximum flow	60 L/min	15.9 gpm	60 L/min	15.9 gpm	90 L/min	23.8 gpm
Connection		-12		-12		-12
Hydraulic for rotation:						
Maximum pressure	140 bar	2030 psi	140 bar	2030 psi	140 bar	2030 psi
Optimum flow	40 L/min	10.6 gpm	40 L/min	10.6 gpm	40 L/min	10.6 gpm
Connection		-8		-8		-8
Excavator — class	9.1-14.5 mt	10-16 st	9.1-14.5 mt	10-16 st	13.6-20.0 mt	15-22 st

\*Weights include standard Quick Coupler mounting brackets.

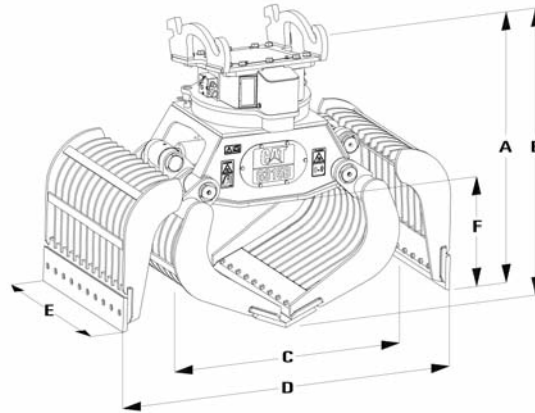

**Specifications** (All dimensions are approximate.)

Model	G315B (Recycling)		G320B (Demolition)		G320B (Recycling)		G325B (Demolition)	
	Capacity	600 L	0.78 yd <sup>3</sup>	750 L	1.11 yd <sup>3</sup>	800 L	1.05 yd <sup>3</sup>	900 L
Weight*	1395 kg	3076 lb	1970 kg	4344 lb	1960 kg	4322 lb	2370 kg	5225 lb
Dimensions:								
<b>A</b> Length	1455 mm	57"	1630 mm	64"	1630 mm	64"	1630 mm	64"
<b>B</b> Length	1550 mm	61"	1725 mm	68"	1725 mm	68"	1725 mm	68"
<b>C</b> Length	1360 mm	54"	1540 mm	61"	1505 mm	59"	1540 mm	61"
<b>D</b> Length	2000 mm	79"	2200 mm	87"	2200 mm	87"	2200 mm	87"
<b>E</b> Width	1000 mm	39"	1100 mm	43"	1100 mm	43"	1350 mm	53"
<b>F</b> Height	570 mm	22"	625 mm	25"	625 mm	25"	625 mm	25"
Closing force	52 kN	11,700 lb	66 kN	14,850 lb	66 kN	14,850 lb	66 kN	14,850 lb
Hydraulic for open/close:								
Maximum pressure	350 bar	5076 psi	350 bar	5076 psi	350 bar	5076 psi	350 bar	5076 psi
Maximum flow	90 L/min	23.8 gpm	120 L/min	31.7 gpm	120 L/min	31.7 gpm	120 L/min	31.7 gpm
Connection	-12		-16		-16		-16	
Hydraulic for rotation:								
Maximum pressure	140 bar	2030 psi	140 bar	2030 psi	140 bar	2030 psi	140 bar	2030 psi
Optimum flow	40 L/min	10.6 gpm	40 L/min	10.6 gpm	40 L/min	10.6 gpm	40 L/min	10.6 gpm
Connection	-8		-8		-8		-8	
Excavator — class	13.6-20.0 mt	15-22 st	18.1-26.3 mt	20-29 st	18.1-26.3 mt	20-29 st	25-38 mt	27.5-41.8 st

\*Weights include standard Quick Coupler mounting brackets.

**Features:**

- Continuous, bi-directional 360° hydraulic rotation.
- Heavy-duty, fully protected cylinders.
- Tines constructed of high-strength wear-resistant steel.

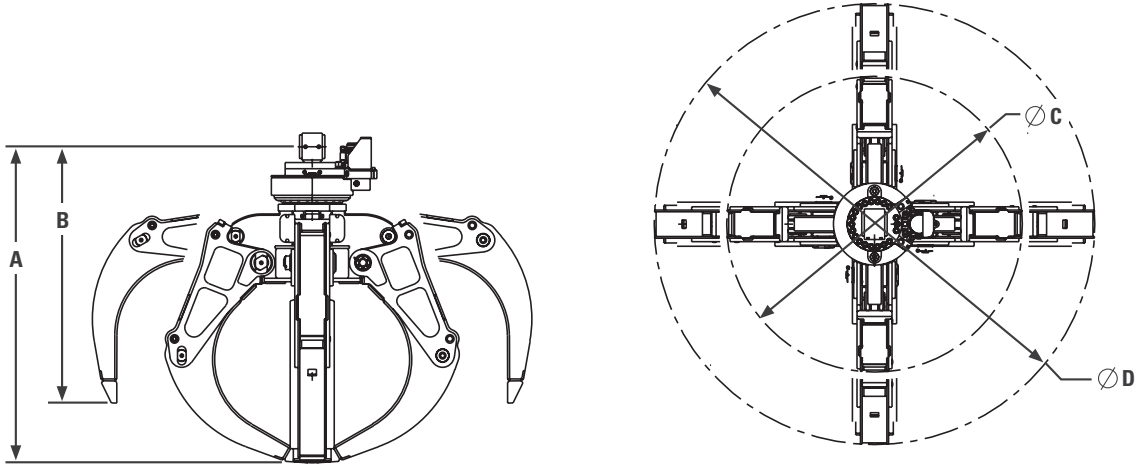

Model		GSH15B	GSH20B		GSH22B		
Part number		293-3202	292-6768	292-7730	292-7743	259-9691	259-9704
Industry capacity class	<b>L</b> (yd <sup>3</sup> )	600 (0.75)	600 (0.75)	800 (1.00)	1000 (1.25)	1000 (1.50)	1500 (2.00)
Operating weight	<b>kg</b> ( <b>lb</b> )	1215 (2679)	1575 (3472)	1615 (3560)	1660 (3660)	2390 (5269)	2410 (5313)
Maximum lift capacity	<b>kg</b> ( <b>lb</b> )	4000 (8818)	8000 (17,637)	8000 (17,637)	8000 (17,637)	12 000 (26,455)	12 000 (26,455)
<b>Dimensions</b>							
<b>A</b> Height — tines closed*	<b>mm</b> ( <b>in</b> )	1740 (68.50)	1720 (67.72)	1860 (73.23)	2010 (79.13)	2175 (85.63)	2265 (89.17)
<b>B</b> Height — tines open*	<b>mm</b> ( <b>in</b> )	1385 (54.53)	1440 (56.69)	1510 (59.45)	1590 (62.60)	1830 (72.05)	1880 (72.36)
<b>C</b> Diameter — tines closed	<b>mm</b> ( <b>in</b> )	1540 (60.63)	1735 (68.31)	1735 (68.31)	1735 (68.31)	2050 (80.71)	2050 (80.71)
<b>D</b> Diameter — tines open	<b>mm</b> ( <b>in</b> )	2415 (95.08)	2390 (94.09)	2595 (101.97)	2855 (102.40)	2950 (116.14)	3050 (120.08)

\*Includes hydraulic rotator, excludes machine link.



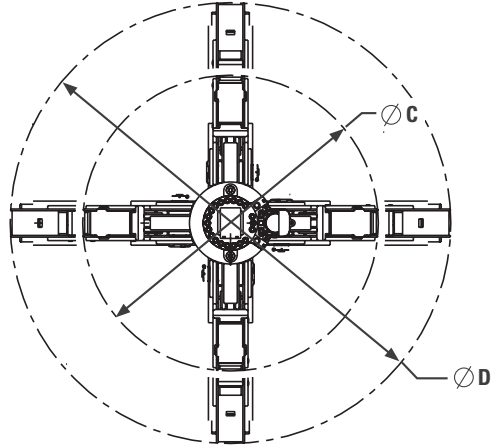
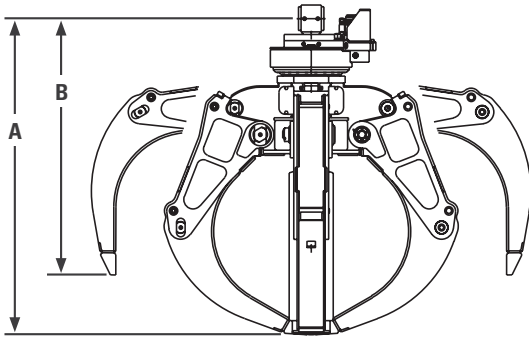

Model	GSH15B		GSH20B		GSH22B		
Part number	293-3202	292-6768	292-7730	292-7743	259-9691	259-9704	
<b>Dimensions</b>							
Ground clearance — tines open	mm (in)	640 (25.20)	645 (25.40)	715 (28.15)	790 (31.10)	900 (35.43)	955 (37.60)
Pin diameter	mm (in)	70 (2.76)	80 (3.15)	80 (3.15)	80 (3.15)	90 (3.54)	90 (3.54)
Width of crosshead	mm (in)	114 (4.49)	150 (5.91)	150 (5.91)	150 (5.91)	200 (7.87)	200 (7.87)
Overall width	mm (in)	1810 (71.26)	1800 (70.87)	1930 (75.98)	2125 (83.66)	2230 (87.80)	2320 (91.34)
Maximum opening	mm (in)	2121 (83.50)	2064 (81.26)	2305 (90.75)	2552 (100.47)	2522 (99.29)	2675 (105.31)
<b>Hydraulic Open/Close</b>							
Maximum pressure	bar (psi)	350 (5076)	350 (5076)	350 (5076)	350 (5076)	350 (5076)	350 (5076)
Optimum flow	L/min (gpm)	100 (26.42)	150 (39.63)	150 (39.63)	150 (39.63)	200 (52.83)	200 (52.83)
<b>Hydraulic Rotation</b>							
Maximum pressure	bar (psi)	180 (2610)	200 (2900)	200 (2900)	200 (2900)	200 (2900)	200 (2900)
Optimum pressure	bar (psi)	140 (2030)	160 (2320)	160 (2320)	160 (2320)	160 (2320)	160 (2320)
Optimum flow	L/min (gpm)	20 (5.28)	20 (5.28)	20 (5.28)	20 (5.28)	20 (5.28)	20 (5.28)

### Matching Guide

	Boom Length		Stick Length		GSH15B	GSH20B			GSH22B	
	m	(ft/in)	m	(ft/in)	0.57 m <sup>3</sup> (0.75 yd <sup>3</sup> )	0.57 m <sup>3</sup> (0.75 yd <sup>3</sup> )	0.76 m <sup>3</sup> (1.00 yd <sup>3</sup> )	0.96 m <sup>3</sup> (1.25 yd <sup>3</sup> )	1.15 m <sup>3</sup> (1.50 yd <sup>3</sup> )	1.53 m <sup>3</sup> (2.00 yd <sup>3</sup> )
M318C MH	6.2	(20'3")	4.9	(16'1")	X					
M318D MH	6.2	(20'3")	4.9	(16'1")	X					
M322C MH	6.8	(22'3")	4.9	(16'1")	X	+	+	+		
			5.9	(19'4")	-	-	X			
M322D MH	6.8	(22'4")	4.9	(16'1")	X	+	+	+		
			5.9	(19'4")	-	-	X			
M325C MH	8.9	(29'0")	6.0	(19'8")		-	X	+		
			7.4	(24'4")		X				
M325C L MH	8.9	(29'0")	6.0	(19'8")		-	X	+		
			7.4	(24'4")		-	X			
M325D MH	8.9	(29'0")	6.0	(19'8")		-	X	+		
			7.4	(24'4")		X				
M325D L MH	8.9	(29'0")	6.0	(19'8")		-	-	X	+	
			7.4	(24'4")		-	X			
320C MH	6.7	(21'10")	5.5	(17'11")	X					
325C MH	8.4	(27'5")	5.5	(17'11")		-	X			
	8.85	(29'0")	6.0	(19'8")		X				
325D MH	8.85	(29'0")	6.0	(19'8")		-	X			
			7.4	(24'4")		X				
330C MH	9.1	(29'10")	6.0	(19'8")		-	X			
330D MH	9.2	(30'2")	6.1	(20'0")		-	-	-	X	
			7.6	(24'11")		-	-	X		
W345C MH	9.9	(32'6")	7.4	(24'4")					-	X
			9.1	(29'10")					-	X
345C MH	9.9	(32'6")	7.4	(24'4")					-	X
			9.1	(29'10")					X	

X

Primary match for good stability in average scrap handling situations. Considers a material density in the 1200 kg/m<sup>3</sup> (2000 lb/yd<sup>3</sup>) range.

+

Secondary match for **less** dense material.

-

Secondary match for **more** dense material.

### Guarding Recommendation

Orange Peel Grapples used in hazardous applications like scrap and material handling can create a need for special operator guarding due to flying objects. When using an Orange Peel Grapple, additional protective devices such as a front screen, Falling

Object Guarding System (FOGS, includes top and front guarding), thick polycarbonate windshields or a combination of these is recommended by Caterpillar. Contact your Cat dealer for operator guarding options on your machine.

**Features:**

- Suitable for a wide range of applications.
- Maximum component protection; lower operating cost.
- Low profile.
- High stability.
- Protected hydraulics.
- Connection lines protection guard.
- Tines constructed of high-strength wear resistant steel.
- Continuous, bi-directional 360° hydraulic rotator.
- Pressure limiting valve for opening and closing.
- Heavy-duty, cushioned cylinders with swing bearings on both sides.
- Maintenance covers for easy access to all maintenance points.
- Weld-on replaceable tips.
- High commonality of parts between 5 and 4 tine configurations.
- Hardened steel-alloy pins.
- High closing force.
- Excellent material penetration.
- Superior lifting capacity.

**Selection by Application**

Grapple Application		4 Tines				5 Tines			
		O	S	C	N	O	S	C	N
Handling Scrap, Iron and Steel	Small-sized pieces (shredded)	x				x			
	Large-sized pieces up to 1000 × 1000 mm (39" × 39") (steel scrap, wrought iron, white goods, motor blocks)								
	Heavy/long-sized pieces (I-beams, pipes, plates)			x				x	
	Car bodies			x				x	
Handling Nonferrous Scrap Metals	Small-sized pieces (beverage cans, electric devices)	x				x			
	Large-sized pieces (car radiators, batteries)								
	Wires and cables (copper, lead)								
Other Nonferrous Materials	Waste								
	Rocks, concrete blocks			x				x	

Very good  
  Good  
 x Not Recommended  
 **O** Open   **S** Semi-closed   **C** Closed   **N** Narrow

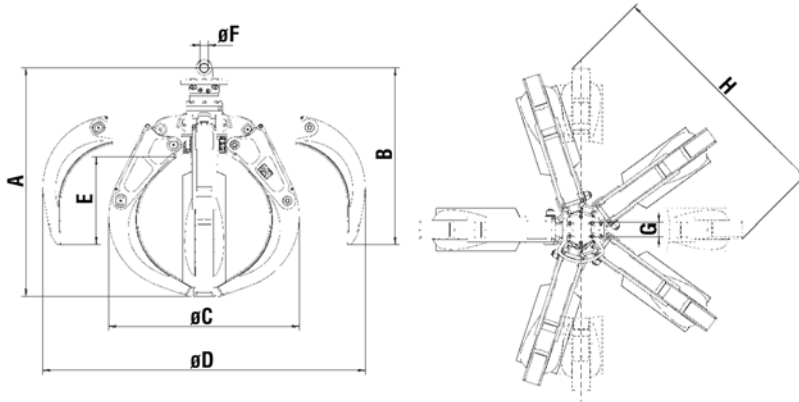

**Specifications** (All dimensions and weights are approximate.)

Model	GSH15B		GSH15B		GSH15B		GSH15B	
	400		500		600		800	
Type								
Recommended carrier weight:								
Excavator	15-21 mt	<b>16.5-23.1 st</b>	15-21 mt	<b>16.5-23.1 st</b>	15-21 mt	<b>16.5-23.1 st</b>	15-21 mt	<b>16.5-23.1 st</b>
Material Handler	18-25 mt	<b>19.8-27.6 st</b>	18-25 mt	<b>19.8-27.6 st</b>	18-25 mt	<b>19.8-27.6 st</b>	18-25 mt	<b>19.8-27.6 st</b>
Capacity	0.4 m <sup>3</sup>	<b>1.0 yd<sup>3</sup></b>	0.5 m <sup>3</sup>	<b>1.0 yd<sup>3</sup></b>	0.6 m <sup>3</sup>	<b>0.75 yd<sup>3</sup></b>	0.8 m <sup>3</sup>	<b>1.0 yd<sup>3</sup></b>
<b>5 Tines</b>								
Operating weight:								
open	1375 kg	<b>3027 lb</b>	1380 kg	<b>3043 lb</b>	1395 kg	<b>3076 lb</b>	1465 kg	<b>3230 lb</b>
semi-closed	1445 kg	<b>3186 lb</b>	1455 kg	<b>3208 lb</b>	1475 kg	<b>3252 lb</b>	1545 kg	<b>3407 lb</b>
closed	1530 kg	<b>3374 lb</b>	1540 kg	<b>3411 lb</b>	1575 kg	<b>3473 lb</b>	1655 kg	<b>3655 lb</b>
narrow	—	—	—	—	1450 kg	<b>3386 lb</b>	1515 kg	<b>3341 lb</b>
<b>4 Tines</b>								
Operating weight:								
open	1155 kg	<b>2538 lb</b>	1160 kg	<b>2558 lb</b>	1175 kg	<b>2591 lb</b>	1210 kg	<b>2668 lb</b>
semi-closed	1225 kg	<b>2701 lb</b>	1235 kg	<b>2723 lb</b>	1250 kg	<b>2756 lb</b>	1300 kg	<b>2867 lb</b>
closed	1355 kg	<b>2988 lb</b>	1375 kg	<b>3032 lb</b>	1410 kg	<b>3109 lb</b>	1495 kg	<b>3296 lb</b>
narrow	—	—	—	—	1215 kg	<b>2679 lb</b>	1260 kg	<b>2778 lb</b>
Dimensions:								
<b>A</b>	1670 mm	<b>66"</b>	1700 mm	<b>67"</b>	1760 mm	<b>69"</b>	1890 mm	<b>74"</b>
<b>B</b>	1350 mm	<b>53"</b>	1370 mm	<b>54"</b>	1400 mm	<b>55"</b>	1460 mm	<b>57"</b>
<b>C</b>	1500 mm	<b>59"</b>	1500 mm	<b>59"</b>	1500 mm	<b>59"</b>	1500 mm	<b>59"</b>
<b>D</b>	2190 mm	<b>86"</b>	2250 mm	<b>89"</b>	2340 mm	<b>92"</b>	2550 mm	<b>100"</b>
<b>E</b>	600 mm	<b>24"</b>	620 mm	<b>24"</b>	650 mm	<b>26"</b>	710 mm	<b>28"</b>
<b>F</b>	70 mm	<b>3"</b>	70 mm	<b>3"</b>	70 mm	<b>3"</b>	70 mm	<b>3"</b>
<b>G</b>	114 mm	<b>4"</b>	114 mm	<b>4"</b>	114 mm	<b>4"</b>	114 mm	<b>4"</b>
<b>H</b>	1440 mm	<b>57"</b>	1480 mm	<b>58"</b>	1540 mm	<b>57"</b>	1670 mm	<b>66"</b>
<b>I</b>	2085 mm	<b>82"</b>	2145 mm	<b>84"</b>	2230 mm	<b>88"</b>	2430 mm	<b>96"</b>
<b>I (4 tines)</b>	1700 mm	<b>67"</b>	1740 mm	<b>69"</b>	1810 mm	<b>71"</b>	1970 mm	<b>78"</b>
Hydraulic open/close:								
Maximum pressure	350 bar	<b>5075 psi</b>	350 bar	<b>5075 psi</b>	350 bar	<b>5075 psi</b>	350 bar	<b>5075 psi</b>
Optimum flow	100 L/min	<b>26 gpm</b>	100 L/min	<b>26 gpm</b>	100 L/min	<b>26 gpm</b>	100 L/min	<b>26 gpm</b>
Hydraulic rotation:								
Maximum pressure	140 bar	<b>2030 psi</b>	140 bar	<b>2030 psi</b>	140 bar	<b>2030 psi</b>	140 bar	<b>2030 psi</b>
Optimum flow	20 L/min	<b>5 gpm</b>	20 L/min	<b>5 gpm</b>	20 L/min	<b>5 gpm</b>	20 L/min	<b>5 gpm</b>

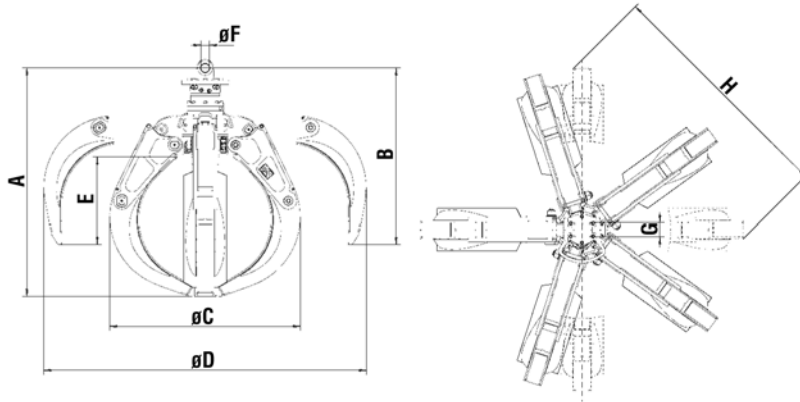

**Specifications** (All dimensions and weights are approximate.)

<b>Model</b>	<b>GSH20B</b>		<b>GSH20B</b>		<b>GSH20B</b>	
	<b>600</b>		<b>800</b>		<b>1000</b>	
Type						
Recommended carrier weight:						
Excavator	20-30 mt	<b>22-33.1 st</b>	20-30 mt	<b>22-33.1 st</b>	20-30 mt	<b>22-33.1 st</b>
Material Handler	25-35 mt	<b>27.6-49.6 st</b>	25-35 mt	<b>27.6-49.6 st</b>	25-35 mt	<b>27.6-49.6 st</b>
Capacity	0.6 m <sup>3</sup>	<b>0.75 yd<sup>3</sup></b>	0.8 m <sup>3</sup>	<b>1.0 yd<sup>3</sup></b>	1.0 m <sup>3</sup>	<b>1.25 yd<sup>3</sup></b>
<b>5 Tines</b>						
Operating weight:						
open	1820 kg	<b>4013 lb</b>	1855 kg	<b>4090 lb</b>	1900 kg	<b>4190 lb</b>
semi-closed	1905 kg	<b>4201 lb</b>	1955 kg	<b>4311 lb</b>	2020 kg	<b>4454 lb</b>
closed	1985 kg	<b>4377 lb</b>	2055 kg	<b>4531 lb</b>	2145 kg	<b>4730 lb</b>
narrow	1870 kg	<b>4123 lb</b>	1920 kg	<b>4234 lb</b>	1975 kg	<b>4355 lb</b>
<b>4 Tines</b>						
Operating weight:						
open	1545 kg	<b>3407 lb</b>	1570 kg	<b>3462 lb</b>	1605 kg	<b>3539 lb</b>
semi-closed	1615 kg	<b>3561 lb</b>	1655 kg	<b>3649 lb</b>	1705 kg	<b>3760 lb</b>
closed	1745 kg	<b>3848 lb</b>	1820 kg	<b>4013 lb</b>	1910 kg	<b>4212 lb</b>
narrow	1575 kg	<b>3473 lb</b>	1615 kg	<b>3561 lb</b>	1660 kg	<b>3660 lb</b>
Dimensions:						
<b>A</b>	1720 mm	<b>68"</b>	1860 mm	<b>73"</b>	2010 mm	<b>79"</b>
<b>B</b>	1440 mm	<b>57"</b>	1510 mm	<b>59"</b>	1590 mm	<b>63"</b>
<b>C</b>	1735 mm	<b>68"</b>	1735 mm	<b>68"</b>	1735 mm	<b>68"</b>
<b>D</b>	2390 mm	<b>94"</b>	2595 mm	<b>102"</b>	2855 mm	<b>112"</b>
<b>E</b>	645 mm	<b>25"</b>	715 mm	<b>28"</b>	790 mm	<b>31"</b>
<b>F</b>	80 mm	<b>3"</b>	80 mm	<b>3"</b>	80 mm	<b>3"</b>
<b>G</b>	150 mm	<b>6"</b>	150 mm	<b>6"</b>	150 mm	<b>6"</b>
<b>H</b>	1530 mm	<b>60"</b>	1640 mm	<b>65"</b>	1800 mm	<b>71"</b>
<b>I</b>	2210 mm	<b>87"</b>	2395 mm	<b>94"</b>	2635 mm	<b>104"</b>
<b>H (4 tines)</b>	1800 mm	<b>71"</b>	1930 mm	<b>76"</b>	2125 mm	<b>84"</b>
Hydraulic open/close:						
Maximum pressure	350 bar	<b>5075 psi</b>	350 bar	<b>5075 psi</b>	350 bar	<b>5075 psi</b>
Optimum flow	150 L/min	<b>40 gpm</b>	150 L/min	<b>40 gpm</b>	150 L/min	<b>40 gpm</b>
Hydraulic rotation:						
Maximum pressure	200 bar	<b>2900 psi</b>	200 bar	<b>2900 psi</b>	200 bar	<b>2900 psi</b>
Optimum flow	20 L/min	<b>5 gpm</b>	20 L/min	<b>5 gpm</b>	20 L/min	<b>5 gpm</b>

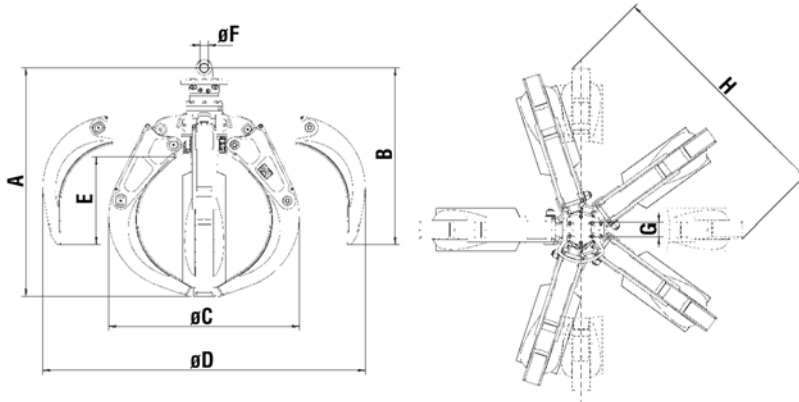

**Specifications** (All dimensions and weights are approximate.)

Model	GSH22B 600		GSH22B 800		GSH22B 1000	
Type						
Recommended carrier weight:						
Excavator	22-50 mt	<b>24.3-55.1 st</b>	22-50 mt	<b>24.3-55.1 st</b>	22-50 mt	<b>24.3-55.1 st</b>
Material Handler	35-60 mt	<b>38.6-66.1 st</b>	35-60 mt	<b>38.6-66.1 st</b>	35-60 mt	<b>38.6-66.1 st</b>
Capacity	0.6 m <sup>3</sup>	<b>0.75 yd<sup>3</sup></b>	0.8 m <sup>3</sup>	<b>1.0 yd<sup>3</sup></b>	1.0 m <sup>3</sup>	<b>1.25 yd<sup>3</sup></b>
<b>5 Tines</b>						
Operating weight:						
open	2660 kg	<b>5865 lb</b>	2715 kg	<b>4796 lb</b>	2740 kg	<b>6042 lb</b>
semi-closed	2770 kg	<b>6108 lb</b>	2855 kg	<b>6295 lb</b>	2890 kg	<b>6372 lb</b>
closed	2860 kg	<b>6306 lb</b>	2980 kg	<b>6571 lb</b>	3030 kg	<b>6681 lb</b>
narrow	—	—	—	—	2855 kg	<b>6295 lb</b>
<b>4 Tines</b>						
Operating weight:						
open	2255 kg	<b>4972 lb</b>	2295 kg	<b>5060 lb</b>	2315 kg	<b>5105 lb</b>
semi-closed	2350 kg	<b>5182 lb</b>	2415 kg	<b>5325 lb</b>	2440 kg	<b>5380 lb</b>
closed	2530 kg	<b>5696 lb</b>	2650 kg	<b>5843 lb</b>	2700 kg	<b>5954 lb</b>
narrow	—	—	—	—	2390 kg	<b>5270 lb</b>
Dimensions:						
<b>A</b>	1970 mm	<b>70"</b>	2100 mm	<b>83"</b>	2175 mm	<b>86"</b>
<b>B</b>	1710 mm	<b>67"</b>	1785 mm	<b>70"</b>	1830 mm	<b>72"</b>
<b>C</b>	2050 mm	<b>81"</b>	2050 mm	<b>81"</b>	2050 mm	<b>81"</b>
<b>D</b>	2640 mm	<b>104"</b>	2840 mm	<b>112"</b>	2950 mm	<b>116"</b>
<b>E</b>	780 mm	<b>31"</b>	860 mm	<b>34"</b>	900 mm	<b>35"</b>
<b>F</b>	90 mm	<b>4"</b>	90 mm	<b>4"</b>	90 mm	<b>4"</b>
<b>G</b>	200 mm	<b>8"</b>	200 mm	<b>8"</b>	200 mm	<b>8"</b>
<b>H</b>	1530 mm	<b>60"</b>	1840 mm	<b>72"</b>	1900 mm	<b>75"</b>
<b>I</b>	2450 mm	<b>96"</b>	2635 mm	<b>104"</b>	2730 mm	<b>107"</b>
<b>H (4 tines)</b>	2010 mm	<b>79"</b>	2160 mm	<b>85"</b>	2230 mm	<b>88"</b>
Hydraulic open/close:						
Maximum pressure	350 bar	<b>5075 psi</b>	350 bar	<b>5075 psi</b>	350 bar	<b>5075 psi</b>
Optimum flow	200 L/min	<b>53 gpm</b>	200 L/min	<b>53 gpm</b>	200 L/min	<b>53 gpm</b>
Hydraulic rotation:						
Maximum pressure	200 bar	<b>2900 psi</b>	200 bar	<b>2900 psi</b>	200 bar	<b>2900 psi</b>
Optimum flow	20 L/min	<b>5 gpm</b>	20 L/min	<b>5 gpm</b>	20 L/min	<b>5 gpm</b>

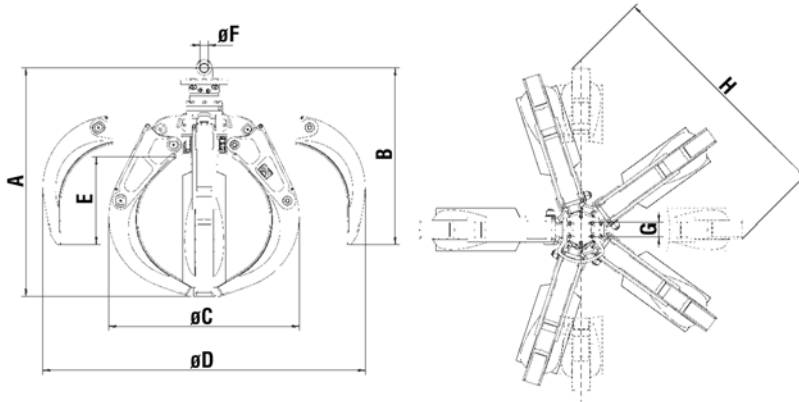

**Specifications** (All dimensions and weights are approximate.)

<b>Model</b>	<b>GSH22B</b>		<b>GSH22B</b>	
	<b>1250</b>		<b>1500</b>	
Type				
Recommended carrier weight:				
Excavator	22-50 mt	<b>24.3-55.1 st</b>	22-50 mt	<b>24.3-55.1 st</b>
Material Handler	35-60 mt	<b>38.6-66.1 st</b>	35-60 mt	<b>38.6-66.1 st</b>
Capacity	1.25 m <sup>3</sup>	<b>1.65 yd<sup>3</sup></b>	1.5 m <sup>3</sup>	<b>2.0 yd<sup>3</sup></b>
<b>5 Tines</b>				
Operating weight:				
open	2780 kg	<b>6130 lb</b>	—	—
semi-closed	2945 kg	<b>6494 lb</b>	—	—
closed	3095 kg	<b>6813 lb</b>	—	—
narrow	—	—	2880 kg	<b>6350 lb</b>
<b>4 Tines</b>				
Operating weight:				
open	2350 kg	<b>5182 lb</b>	—	—
semi-closed	2485 kg	<b>5479 lb</b>	—	—
closed	2760 kg	<b>6086 lb</b>	—	—
narrow	—	—	2410 kg	<b>5314 lb</b>
Dimensions:				
<b>A</b>	2245 mm	<b>88"</b>	2265 mm	<b>89"</b>
<b>B</b>	1870 mm	<b>74"</b>	1880 mm	<b>74"</b>
<b>C</b>	2085 mm	<b>82"</b>	2050 mm	<b>80"</b>
<b>D</b>	3060 mm	<b>120"</b>	3050 mm	<b>120"</b>
<b>E</b>	940 mm	<b>37"</b>	955 mm	<b>38"</b>
<b>F</b>	90 mm	<b>4"</b>	90 mm	<b>4"</b>
<b>G</b>	200 mm	<b>8"</b>	200 mm	<b>8"</b>
<b>H</b>	1980 mm	<b>78"</b>	1980 mm	<b>78"</b>
<b>I</b>	2830 mm	<b>111"</b>	2820 mm	<b>111"</b>
<b>H (4 tines)</b>	2320 mm	<b>91"</b>	2320 mm	<b>91"</b>
Hydraulic open/close:				
Maximum pressure	350 bar	<b>5075 psi</b>	350 bar	<b>5075 psi</b>
Optimum flow	200 L/min	<b>53 gpm</b>	200 L/min	<b>53 gpm</b>
Hydraulic rotation:				
Maximum pressure	200 bar	<b>2900 psi</b>	200 bar	<b>2900 psi</b>
Optimum flow	20 L/min	<b>5 gpm</b>	20 L/min	<b>5 gpm</b>

**Work Tools Matching Guide**

Choosing the proper Orange Peel Grapple can increase productivity and lower your cost per ton.

---

Matching information not available. Please see marketing literature for current matching information.



# Multi-Functional Concrete Crushers Europe, Africa, Middle East

## Features Guarding Recommendation Matching Guide

### Features:

- Multi-functional operation, the crusher combines several demolition operations in one piece of equipment. Breaking out concrete from fixed structures, pulverizing concrete and cutting reinforcement rods and small steel profiles.
- High force-to-weight ratio, the crusher's special cylinder position allows it to maintain the same power with significantly lower weight.
- Enhanced performance, the standard speed valve enables cutting/crushing with great force and in even shorter cycle times.
- Optimized serviceability, the teeth and blades are replaceable and the hydraulics is easy accessible through bolted hatches.

### Guarding Recommendation

Multi-Functional Concrete Crushers used in hazardous applications like breaking out concrete from fixed structures, pulverizing concrete and cutting, can create a need for special operator guarding due to flying objects. When using a Multi-Functional Concrete Crusher, additional protective devices such as a front screen, Falling Object Guarding System (FOGS, includes top and front guarding), thick polycarbonate windshields or a combination of these is recommended by Caterpillar. Contact your Cat dealer for operator guarding options on your machine.

### Matching Guide

#### Multi-Functional Concrete Crushers

Model	Cat Excavator
<b>P315</b>	315C/D, 318C, 319C/D, 320B/C/D, 322B/C, 323D, 324D, 325B/C, 325UHD C/D, 330UHD B/C/D, 345UHD B/C, 385UHD B/C
<b>P325</b>	320D, 322B/C, 324D, 325B/C/D, 329D, 330B/C/D, 336D, 325UHD C/D, 330UHD B/C/D, 345UHD C, 365UHD B/C, 385UHD B/C
<b>P335</b>	325B/C/D, 329D, 330B/C/D, 336D, 345B/C, 365UHD BII/C, 385 UHD B/C
<b>P360</b>	345B/C, 365B/C, 385B/C

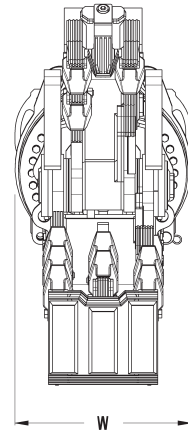
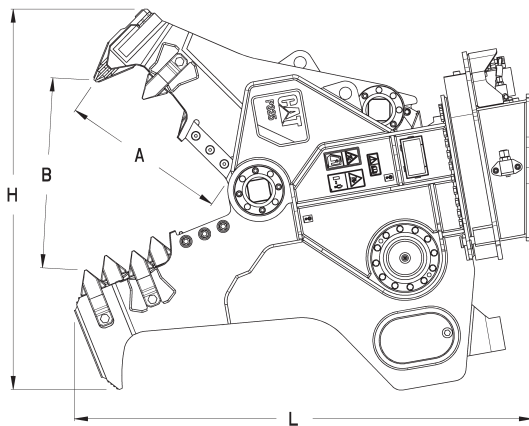

**Specifications and Dimensions**

Model	P315		P325		P335		P360	
Recommended carrier weight, stick mounted	15-25		25-35		35-60		60-85	
Weight* (approximate)	1890 kg	<b>4170 lb</b>	2550 kg	<b>5620 lb</b>	3550 kg	<b>7825 lb</b>	5230 kg	<b>11,530 lb</b>
Closing force:								
at tooth tip	90 mt	<b>99 st</b>	125 mt	<b>138 st</b>	160 mt	<b>176 st</b>	210 mt	<b>231 st</b>
at primary cutter	190 mt	<b>210 st</b>	295 mt	<b>325 st</b>	355 mt	<b>391 st</b>	455 mt	<b>501 st</b>
Dimensions:								
Length	1927 mm	<b>76"</b>	2060 mm	<b>81"</b>	2398 mm	<b>130"</b>	2737 mm	<b>108"</b>
Height	1543 mm	<b>61"</b>	1710 mm	<b>67"</b>	1897 mm	<b>75"</b>	2312 mm	<b>91"</b>
Width	793 mm	<b>31"</b>	793 mm	<b>31"</b>	750 mm	<b>30"</b>	1180 mm	<b>46"</b>
Jaw depth	657 mm	<b>26"</b>	753 mm	<b>30"</b>	877 mm	<b>35"</b>	933 mm	<b>37"</b>
Jaw opening	731 mm	<b>29"</b>	855 mm	<b>34"</b>	983 mm	<b>39"</b>	1201 mm	<b>47"</b>
Cutter length	200 mm	<b>8"</b>	260 mm	<b>10"</b>	350 mm	<b>14"</b>	350 mm	<b>14"</b>
Maximum pressure:								
Crushing circuit	350 bar	<b>5076 psi</b>	350 bar	<b>5076 psi</b>	350 bar	<b>5076 psi</b>	350 bar	<b>5076 psi</b>
Rotation	140 bar	<b>2030 psi</b>	140 bar	<b>2030 psi</b>	140 bar	<b>2030 psi</b>	140 bar	<b>2030 psi</b>
Optimum flow:								
Crushing circuit	150 L/min	<b>40 gpm</b>	200 L/min	<b>53 gpm</b>	300 L/min	<b>79 gpm</b>	400 L/min	<b>105 gpm</b>
Rotation	40 L/min	<b>11 gpm</b>	40 L/min	<b>11 gpm</b>	40 L/min	<b>11 gpm</b>	80 L/min	<b>21 gpm</b>
Time to close	<b>2 sec</b>		<b>2 sec</b>		<b>2.5 sec</b>		<b>3 sec</b>	
Time to open	<b>3 sec</b>		<b>4 sec</b>		<b>4 sec</b>		<b>4 sec</b>	
Crushing capacity:								
Concrete thickness**	550 mm	<b>22"</b>	650 mm	<b>26"</b>	800 mm	<b>31"</b>	950 mm	<b>37"</b>

\*Weight excludes mounting bracket.

\*\*The concrete thickness as published provides an indication of crushing ability. The exact crushing ability depends on proper excavator adjustment, on the tip and amount of rebar, and on the condition of the concrete, jaws and crushers.

**Features:**

- **Ideal for pulverizing from non fixed structures** — The P200 Series is an excellent choice for all those recyclers who need to prepare concrete for fine crushing and is an excellent attachment for secondary demolition. Concrete chunks released during the demolition of concrete structures can be fine-crushed at source. In this process the concrete and the reinforcement are separated. This considerably reduces the transport volume, saving dumping and transportation expenses.
- **Innovative jaw arrangement** — The P200 Series offers wide jaws with pick-up tips, large opening, reversible cutting edges and fast closing times that bring a high return on your investment. This high force-to-weight work tool has been specially developed to reduce the largest possible amount of concrete in the shortest possible time.
- **Enhanced performance** — The hydraulic concrete crusher is a highly productive crusher. The ripper tooth splits concrete instantly and the large number of teeth have a large pulverizing effect. The cylinder of the P200 Series is equipped with a speed valve as standard. This device controls the speed of the cylinder and enables to cut/crush with great force in short cycle times.
- **Optimized serviceability** — Service and repairs are a necessary part of operating any work tool. So the less time and money needed for both, the better. That's why Caterpillar gives major attention to reducing both. The teeth and blades are replaceable and the hydraulics are easily accessible through bolted hatches. Parts commonality is designed into Cat products to significantly benefit owners of several work tools.
- **Long lifetime** — Cat Work Tools are designed to last long. Precision machined and forged parts, wear protection and stress relieving plates as well as fully protected hydraulic cylinder provide a long lifetime of low cost production.

**Guarding Recommendation**

Hydraulic Concrete Pulverizers are used in hazardous applications like breaking out concrete from fixed structures, pulverizing concrete and cutting; creating a need for special operator guarding due to flying objects. When using these tools, additional protective devices such as a front screen, Falling Object Guarding System (FOGS, includes top and front guarding), thick polycarbonate windshields or a combination of these is recommended by Caterpillar. Contact your Cat dealer for operator guarding options on your machine.

**Matching Guide**

**Hydraulic Concrete Pulverizers**

Model	Cat Excavator
<b>P215</b>	315C/D, 318C, 319C/D, 320B/C/D, 322B/C, 323D, 324D, 325B/C/D
<b>P225</b>	320D, 322B/C, 324D, 325B/C/D, 329D, 330B/C/D, 336D
<b>P235</b>	325B/C/D, 329D, 330B/C/D, 336D, 345B/C



**Specifications and Dimensions**

<b>Model</b>	<b>P215</b>		<b>P225</b>		<b>P235</b>	
Recommended carrier weight***:	<b>15-25</b>		<b>25-35</b>		<b>35-60</b>	
Stick mounted						
Weight* (approximate)	1683 kg	<b>3710 lb</b>	2480 kg	<b>5467 lb</b>	3421 kg	<b>7542 lb</b>
Closing force:						
at tooth tip	121 mt	<b>133 st</b>	177 mt	<b>195 st</b>	94 mt	<b>104 st</b>
at primary cutter	235 mt	<b>259 st</b>	338 mt	<b>373 st</b>	401 mt	<b>442 st</b>
Dimensions:						
Length	2414 mm	<b>95"</b>	2615 mm	<b>103"</b>	3046 mm	<b>120"</b>
Height	1372 mm	<b>54"</b>	1645 mm	<b>65"</b>	1918 mm	<b>76"</b>
Width	580 mm	<b>23"</b>	624 mm	<b>25"</b>	708 mm	<b>28"</b>
Jaw depth	722 mm	<b>28"</b>	899 mm	<b>35"</b>	1103 mm	<b>43"</b>
Jaw opening	838 mm	<b>33"</b>	1018 mm	<b>40"</b>	1214 mm	<b>48"</b>
Cutter length	200 mm	<b>8"</b>	260 mm	<b>10"</b>	260 mm	<b>10"</b>
Maximum pressure crushing/cutting	350 bar	<b>5076 psi</b>	350 bar	<b>5076 psi</b>	350 bar	<b>5076 psi</b>
Optimum flow crushing/cutting	150 L/min	<b>40 gpm</b>	200 L/min	<b>53 gpm</b>	300 L/min	<b>79 gpm</b>
Return flow	240 L/min	<b>63 gpm</b>	300 L/min	<b>79 gpm</b>	510 L/min	<b>135 gpm</b>
Time to close		<b>3 sec</b>		<b>3 sec</b>		<b>3.5 sec</b>
Time to open		<b>4 sec</b>		<b>5 sec</b>		<b>4.5 sec</b>
Crushing capacity:						
Concrete thickness**	650 mm	<b>26"</b>	750 mm	<b>30"</b>	900 mm	<b>35"</b>

\*Weight excludes mounting bracket.

\*\*The concrete thickness provides an indication of the crushing capacity. The exact crushing capability depends on excavator operation pressure and performance, on the tip and amount of rebar, and the condition of the concrete, jaws and cutters.

\*\*\*The P200 work tool can also be installed on non-Cat carriers in the listed weight classes by installing a mounting bracket with the right pin-on ears, or with hinges to fit the dedicated CW quick coupler.



# ENGINES

## CONTENTS

Design Data .....	18-2
Rating Explanations .....	18-2
Basic Specifications .....	18-3
Off-Highway Engine Ratings .....	18-5
Olympian Generator Sets .....	18-6
Cat Generator Sets .....	18-10, 18-13
MaK Marine Generator Sets .....	18-12
Cat Marine Engines .....	18-17, 18-19
MaK Marine Engines .....	18-18
Cat Industrial Diesel Applications .....	18-20
Cat Oil and Gas Engines .....	18-25
Cat Railway Power .....	18-30

### Asia

**Caterpillar Asia Pte., Ltd.**  
Jurong, Singapore  
Tel: 65-6828-7118  
Fax: 65-6828-7414

### Australia

**Caterpillar of Australia Pty. Ltd.**  
Victoria, Australia  
Tel: 61-3-9953-9301  
Fax: 61-3-9338-9021

### China

**Caterpillar China Ltd.**  
Beijing, China  
Tel: 86-10-5921-0339  
Fax: 86-10-5921-0022

### Eastern Europe

**Commonwealth of Independent States Caterpillar Overseas S.A.**  
Moscow, Russia  
Tel: 7-095-755-8161  
Fax: 7-095-785-5688

### Europe, Africa,

**Middle East Caterpillar S.A.R.L.**  
Geneva, Switzerland  
Tel: 41-22-849-4444  
Fax: 41-22-849-4139

### Japan

**Caterpillar Power Systems, Inc.**  
Tokyo, Japan  
Tel: 81-3-5786-3800  
Fax: 81-3-5786-3809





**Mexico, The Caribbean, South America Latin America Commercial Division**  
Miami, Florida, U.S.A.  
Tel: 305-476-6800  
Fax: 305-476-6850

**North America Caterpillar Inc.**  
Peoria, Illinois, U.S.A.  
Tel: 309-578-6298  
Fax: 309-578-2559

**E Mail:**  
Cat\_Power@Cat.com

**Web Site/Dealer Locator**  
www. Cat-engines.com

For more information contact your local Cat dealer, or visit the Cat engine and generator set website on [www.cat-engines.com](http://www.cat-engines.com).

	TYPE	NO. OF MODELS	RANGE
	<b>INDUSTRIAL Diesel</b>	33	8.2 to 4920 kW 10.2 to 6598 hp EPA Certified
	<b>Gaseous Fueled</b>	13	56 to 3762 kW 75 to 5045 hp EPA Certified
	<b>GENERATOR SETS</b>		50 Hz kVA w/fan Prime 275-2825 Standby 300-3100
	<b>Diesel High Speed Area</b>		60 Hz ekW w/fan Prime 12-2825 Standby 13-3100
	<b>Gaseous Fueled</b>		50 Hz kVA w/o fan Continuous 80-4825 60 Hz ekW w/o fan Continuous 72-3480
	<b>OLYMPIAN GENERATOR SETS*</b>		50 Hz kVA w/fan Prime 6.8-635 Standby 7.5-700
	<b>Diesel</b>		60 Hz ekW w/fan Prime 8-540 Standby 8.8-600
	<b>Gaseous Fueled</b>		50 Hz kVA w/o fan Standby 13-30 60 Hz ekW w/o fan Continuous 25-300
	<b>MARINE</b>		
	<b>Propulsion</b>	24	93 to 5420 kW 125 to 7268 hp
	<b>Generator Sets</b>	14	50 Hz kVA 10.0 to 5200 Prime 60 Hz kW 12.0 to 4840 Prime

\*Olympian Generator Sets are manufactured exclusively for Cat dealers.

**DESIGN DATA****Diesel Engines**

*Bearings* — Precision-type steel-backed aluminum alloy with lead-tin overlay copper bonded to bearing surface. High load carrying ability and exceptional fatigue strength.

*Block* — Cast from high tensile strength grey iron. Internal ribbing provides added strength.

*Cooling* — Built-in, gear driven centrifugal pump (belt driven for 3116 and 3208) circulates jacket water through engine at all times. Water temperature is thermostatically controlled. Heat exchangers and radiators are available.

*Crankshaft* — Forged steel, dynamically balanced, heat treated and superfinished.

*Cylinder Liners* — Internal surface induction hardened (1.7 L, 3300, 3400, 3500 and 3600 Families) for excellent wear life. Full-length watercooled for efficient heat transfer.

*Fuel System* — Adjustment free for reduced engine maintenance, individual fuel injection pumps have built-in calibration — no adjustment required after fuel nozzle replacement (1.7 L, 1.9 L, 3406E, 3456, 3500 and 3600 families have unit injectors). 3126, 3408E and 3412E use the Cat HEUI system.

*Governor* — Hydra-mechanical (Woodward 3161 on 3500 and 3600 Families) for reliability, good response and smooth, stable load changes. Electronically controlled engines use Caterpillar proprietary software and hardware.

*Lubrication* — Positive displacement gear pump maintains continuous flow of lubricant under pressure to all moving parts. Full-flow filtration is provided by replaceable cellulose filters. Watercooled oil cooler maintains proper oil temperature.

*Pistons* — Three-ring design (two-ring on 3208) reduces friction, provides excellent oil control, and increases engine efficiency.

*Starting* — Electric and air starting systems are offered for most models.

*Valves* — Hardened steel alloy. Valves rotate 3° each time they lift to seat in a new position and allow even heat distribution (except for 3116).

**Gaseous Fueled Engines**

*Combustion System* — The piston design and compression ratios available provide the ability to utilize a wide variety of gaseous fuels as well as provide low emission output (below 2.0 grams/bhp-hr  $\text{NO}_x$ ).

*Fuel System* — Heavy-duty, industrial-type carburetors designed to maintain optimum air-fuel ratio at all loads and speeds.

*Ignition System* — Cat Gaseous Fueled Engines employ a low tension magneto, together with an ignition transformer (one at each cylinder), to provide up to 34 kV to spark plugs. The Cat Electronic Ignition system is also available on certain engines.

**RATING EXPLANATIONS**

All engine ratings listed include such standard accessories as air cleaner and fuel, lube, and jacket water pumps. Power required for auxiliaries such as cooling fans, air compressors, charging alternators, special pumps, etc., must be deducted to arrive at the net power available to drive the load (except as noted). Other ratings are available for specific application and customer requirements, i.e., locomotive, oil field, fire pump, irrigation, etc. Consult your Cat dealer.

**Rating Conditions**

Performance is based on SAE J1995 standard conditions of 100 kPa (29.61 in Hg) and 25° C (77° F). Performance also applies at ISO 3046/1 (except for Spark Ignited Engines), DIN 6271 and BS 5514 standard conditions of 100 kPa (29.61 in Hg), 27° C (81° F) and 60% relative humidity.

Fuel consumption is based on fuel oil having an LHV of 42 780 kJ/kg (18,390 Btu/lb) and weighing 838.9 g/liter (7.001 lb/U.S. gal). All ratings are based on distillate fuel.

**Altitude and Temperature Capabilities**

*Industrial Diesel Engines* — Most intermittent and continuous ratings are applicable to at least 1320 m (5000 ft) elevation without derating. Consult factory for specific applications.

*Gaseous Fueled Engines* — Ratings for turbocharged and aftercooled engines are generally applicable to 1500 m (5000 ft). Naturally aspirated engines are applicable to 150 m (500 ft).

*Diesel Truck Engines* — Refer to specification sheets for altitude capability of individual truck engine ratings.

**Basic Specifications**

Model	Displacement		Config.	Bore x Stroke		Fuel System	Power Range				Elec. Power Gen.	Oil/ Gas	Rail Power
	L	in <sup>3</sup>		mm	in		Marine		Diesel Industrial				
							kW	hp	kW	hp			
C0.5	0.5	30.9	I2	67x72	2.6x2.8	PC			8.2-10.2	11.0-13.7			
C0.7	0.7	46.5	I3	67x72	2.6x2.8	PC			12.2-15.3	16.3-20.5			
C1.1	1.1	69	I3	77x81	3.0x3.2	PC			13.7-21.0	18.4-28.2			
C1.5	1.5	91	I3	84x90	3.3x3.5	PC			20.7-30.0	27.8-40.2			
C1.6	1.5	92	I4	77x81	3.0x3.2	PC			24.6 & 26.5	33.0 & 35.5			
C1.7	1.66	101	I2	84x100	3.3x3.9	PC			24.7 & 26	33.2 & 34.8			
C2.2	2.2	135	I4	84x100	3.3x3.9	PC			27.5-49.2	36.9-66.0			
C3.4	3.3	201	I4	94x120	3.7x4.72	Mech			47-62	63-83			
3054C	4.4	269	I4	105x127	4.1x5.0	Mech			50-97	67-130			
3054E	4.4	269	I4	105x127	4.1x5.0	Elect			64-97	86-130			
C4.4	4.4	269	I4	105x127	4.1x5.0	Mech			54-83	72-111.3			
C4.4 ACERT	4.4	269	I4	105x127	4.1x5.0	Elect			61.5-106	82.5-142			
C6.6 ACERT	6.6	402.8	I6	105x127	4.1x5.0	Elect			89-205	119.4-274.9			
3056	6	365	I6	100x127	3.94x5.0	MUI	93-153	125-205					
3126B	7.24	442	I6	110x127	4.33x5.0	HEUI							
C7	7.24	442	I6	110x127	4.33x5.0	HEUI	187-276	250-270					
C11 ACERT	11.1	677	I6	130x140	5.12x5.51	EUI			242-336	325-450			
C12	12	732	I6	130x150	5.1x5.9	EUI	254-448	340-600					
C12 ACERT	12	732	I6	130x150	5.1x5.9	EUI	492-526	660-705					
3406	14.6	893	I6	137x165	5.4x6.5								
3406C	14.6	893	I6	137x165	5.4x6.5				201-392	270-525			
C15 ACERT	14.6	891	I6	137x165	5.4x6.5	EUI	597-636	800-853					
C16	15.8	964	I6	140x171	5.5x6.75	EUI							
3408	18	1099	V8	137x152	5.4x6.0								
C18	18.1	1106	I6	145x183	5.7x7.2	HEUI	339-747	454-1001					
C18 ACERT	18.1	1106	I6	145x183	5.7x7.2	HEUI	339-847	454-1136	429-597	575-800			
3412	27	1649	V12	137x152	5.4x6.0								
C27 ACERT	27	1648	V12	137.7x152.4	5.42x5.99	MEUI			597-858	800-1150			
C32	32.1	1959	V12	145x162	5.7x6.4	EUI	1156-1232	1550-1652					
C32 ACERT	32.1	1959	V12	145x162	5.71x6.38		492-1342	660-1800	708-1007	950-1350			
3508	34.5	2105	V8	170x190	6.7x7.5	MUI	526-857	705-1150	507-746	680-1000			
3508B	34.5	2105	V8	170x190	6.7x7.5	EUI	578-1118	775-1500	746-820	1000-1100			
3508C	34.5	2107	V8	170x190	6.7x7.5	EUI	578-820	775-1100					
3512	51.8	3158	V12	170x190	6.7x7.5	MUI	900-1305	1207-1750	761-1119	1020-1500			
3512B	51.8	3158	V12	170x190	6.7x7.5	EUI	820-1678	1100-2250	1119-1231	1500-1650			
3512B HD	58.6	3576	V12	170x215	6.7x8.5	MUI	1118-1500	1500-2012					
3512C	51.8	3161	V12	170x190	6.69x7.48	EUI	1119-1230	1500-1650					
3512C HD	58.6	3574	V12	170x215	6.69x8.46	EUI	1350-1902	1810-2551					
3516	69	4210	V16	170x190	6.7x7.5	MUI	1195-1640	1603-2200	1011-1492	1355-2000			
3516B	69	4210	V16	170x190	6.7x7.5	EUI	1230-2237	1650-3000	1492-1566	2000-2100			
3516B HD	78	4766	V16	170x215	6.7x8.5	EUI	1398-2000	1875-2682					
3516C	69	4211	V16	170x190	6.69x7.48	EUI	1492-1641	2000-2200					
3516C HD	78	4765	V16	170x215	6.69x8.46	EUI	1825-2525	2448-3386					
C280-6	111	6773	I6	280x300	11.0x11.8	EUI	1730-2030	2320-2722					
3606	110.8	6774	I6	280x300	11x11.8	MUI			1490-1850	1998-2481			
C280-8	148	9031	I8	280x300	11.0 x 11.8	EUI	2300-2710	3084-3634					
3608	148	9031	I8	280x300	11x11.8	MUI			1980-2460	2655-3300			
C280-12	222	13,546	V12	280x300	11.0x11.8	EUI	3460-4060	4640-5444					
3612	221.7	13,527	V12	280x300	11x11.8	MUI			2980-3700	3996-4962			
C280-16	296	18,062	V16	280x300	11.0x11.8	EUI	4600-5420	6169-7268					
3616	295.6	18,036	V16	280x300	11x11.8	MUI			3960-4920	5310-6598			

Mech — Mechanical pump and line  
 MUI — Mechanical Unit Injection  
 EUI — Electronic Unit Injection  
 \*See Truck Listing for EUR02 Ratings.

PC — Precombustion Chamber  
 Elect — Electronic

See our listings for Generator Sets and Power Modules for complete information.

See our listings for Oil and Gas Engines for complete information.

See our listings for Railway Power for complete information.



## Basic Specifications

MaK Model	Output range		Config.	Speed	Displacement		Bore x Stroke		Fuel System	Electric Power Gen.
	kW	mhp		rpm	L	in <sup>3</sup>	mm	in		
6 M 20 C	1020	1390	inline	900	57	3478	200x300	7.9x11.8	UP	
	1140	1550	inline	1000	57	3478	200x300	7.9x11.8	UP	
8 M 20 C	1360	1850	inline	900	75	4576	200x300	7.9x11.8	UP	
	1520	2070	inline	1000	75	4576	200x300	7.9x11.8	UP	
9 M 20 C	1530	2080	inline	900	85	5187	200x300	7.9x11.8	UP	
	1710	2325	inline	1000	85	5187	200x300	7.9x11.8	UP	
6 M 25 C	1800	2450	inline	720	123	7506	255x400	10x15.75	UP	
	1900	2585	inline	720	123	7506	255x400	10x15.75	UP	
	1850	2525	inline	750	123	7506	255x400	10x15.75	UP	
	2000	2720	inline	750	123	7506	255x400	10x15.75	UP	
8 M 25 C	2320	3155	inline	720	163	9946	255x400	10x15.75	UP	
	2540	3455	inline	720	163	9946	255x400	10x15.75	UP	
	2400	3265	inline	750	163	9946	255x400	10x15.75	UP	
	2660	3620	inline	750	163	9946	255x400	10x15.75	UP	
9 M 25 C	2610	3550	inline	720	184	11,228	255x400	10x15.75	UP	
	2850	3875	inline	720	184	11,228	255x400	10x15.75	UP	
	2700	3670	inline	750	184	11,228	255x400	10x15.75	UP	
	3000	4080	inline	750	184	11,228	255x400	10x15.75	UP	
6 M 32 C	2880	3915	inline	600	232	14,158	320x480	12.6x18.9	UP	
	3000	4080	inline	600	232	14,158	320x480	12.6x18.9	UP	
8 M 32 C	3840	5220	inline	600	309	18,856	320x480	12.6x18.9	UP	
	4000	5440	inline	600	309	18,856	320x480	12.6x18.9	UP	
9 M 32 C	4320	5875	inline	600	347	21,175	320x480	12.6x18.9	UP	
	4500	6120	inline	600	347	21,175	320x480	12.6x18.9	UP	
12 M 32 C	5760	7835	vee	720	405	24,715	320x420	12.6x16.5	UP	
	6000	8160	vee	750	405	24,715	320x420	12.6x16.5	UP	
16 M 32 C	7680	10,445	vee	720	541	33,014	320x420	12.6x16.5	UP	
	8000	10,880	vee	750	541	33,014	320x420	12.6x16.5	UP	
6 M 43 C	5400	7345	inline	500	531	32,404	430x610	16.93x24	UP	
	5400	7345	inline	514	531	32,404	430x610	16.93x24	UP	
	6000	8160	inline	500	531	32,404	430x610	16.93x24	UP	
	6000	8160	inline	514	531	32,404	430x610	16.93x24	UP	
7 M 43 C	6300	8570	inline	500	620	37,835	430x610	16.93x24	UP	
	6300	8570	inline	514	620	37,835	430x610	16.93x24	UP	
	7000	9520	inline	500	620	37,835	430x610	16.93x24	UP	
	7000	9520	inline	514	620	37,835	430x610	16.93x24	UP	
8 M 43 C	7200	9790	inline	500	709	43,266	430x610	16.93x24	UP	
	7200	9790	inline	514	709	43,266	430x610	16.93x24	UP	
	8000	10,880	inline	500	709	43,266	430x610	16.93x24	UP	
	8000	10,880	inline	514	709	43,266	430x610	16.93x24	UP	
9 M 43 C	8100	11,015	inline	500	797	48,636	430x610	16.93x24	UP	
	8100	11,015	inline	514	797	48,636	430x610	16.93x24	UP	
	9000	12,240	inline	500	797	48,636	430x610	16.93x24	UP	
	9000	12,240	inline	514	797	48,636	430x610	16.93x24	UP	
12 M 43 C	10 800	14,690	vee	500	1063	64,868	430x610	16.93x24	UP	
	10 800	14,690	vee	514	1063	64,868	430x610	16.93x24	UP	
	12 000	16,320	vee	500	1063	64,868	430x610	16.93x24	UP	
	12 000	16,320	vee	514	1063	64,868	430x610	16.93x24	UP	
16 M 43 C	14 400	19,585	vee	500	1417	86,471	430x610	16.93x24	UP	
	14 400	19,585	vee	514	1417	86,471	430x610	16.93x24	UP	
	16 000	21,760	vee	500	1417	86,471	430x610	16.93x24	UP	
	16 000	21,760	vee	514	1417	86,471	430x610	16.93x24	UP	

See our listings for Generator Sets for complete information.

UP — Unit Pump

**Off-Highway Engine Ratings**

**C7 ACERT Ratings**

Advertised hp	Maximum hp	Peak Torque lb-ft	Advertised Speed
190	207	520	2500
210 AT	216	520	2500
210	210	520	2500
210	210	605	2500
230	230	540	2400
230	230	660	2400
250	250	660	2400
250	250	800	2400
275	275	800	2400
275	275	860	2400
300	300	800	2400
300	300	860	2400
330	330	860	2400

AT — Automatic Transmission

**C9 ACERT Ratings**

Advertised hp	Maximum hp	Peak Torque lb-ft	Advertised Speed
275	275	860	2100
330	330	1150	2100
335	350	1050	2100
350	350	1100	2100
400	400	1100	2100

**C11 ACERT Ratings**

Advertised hp	Maximum hp	Peak Torque lb-ft	Advertised Speed
305	315	1050	2100
335	350	1250	2100
350	365	1350	2100

**C13 ACERT Ratings**

Advertised hp	Maximum hp	Peak Torque lb-ft	Advertised Speed
335	420	1550	2100
410	425	1450	2100
410	425	1550	2100
430	445	1550	2100
430	445	1650	2100
470	485	1550	2100
525	525	1650	2100
410	425	1450/1550	2100

**C15 ACERT Ratings**

Advertised hp	Maximum hp	Peak Torque lb-ft	Advertised Speed
435	450	1550	2100
435	450	1650	2100
475	490	1650	2100
475	490	1850	2100
500	515	1850	2100
550	550	1850	2100
435/500	515	1550/1650	2100
500	515	1650	2100
500	515	1850	2100
550	550	1850	2100

## Olympian Generator Sets

## Outside North America Diesel Ratings

Model	60 Hz			50 Hz		
	rpm	Standby	Prime	rpm	Standby	Prime
		ekW			kVA	
<b>3-Phase Output*</b>						
GEP9.5	—	—	—	1500	9.5	8.5
GEP13.5	1800	13	12	1500	13.8	12.5
GEP18	1800	17	15.5	1500	18	16.5
GEP22	1800	20	18	1500	22	20
GEP33	1800	30	27	1500	33	30
GEP44	1800	40	36	1500	44	40
GEP50	1800	45	40	1500	50	45
GEP55P	1800	50	45	1500	55	50
GEP65	1800	60	55	1500	65	60
GEP88	1800	80	72	1500	88	80
GEP110	1800	100	90.4	1500	110	100
GEP150	1800	165	150	1500	150	135
GEP165	—	—	—	1500	165	150
GEP200	1800	175	157.5	1500	200	180
GEH220	1800	200	180	1500	220	200
GEH250	—	—	—	1500	250	230
GEH275	—	—	—	1500	275	250
GEP400	—	—	—	1500	400	350
GEP450	—	—	—	1500	450	400
GEP500	—	—	—	1500	500	450
GEP550	—	—	—	1500	550	500
GEP605	—	—	—	1500	605	550
GEP650	—	—	—	1500	650	591
GEP660	—	—	—	1500	660	600
GEP700	—	—	—	1500	700	635
GEP750	1800	600	540	—	—	—

\*Ratings at 0.8 pf and 25° C (77° F).

**Rating Definitions:**

**Standby** — These ratings are applicable for supplying continuous power (at variable load) in the event of a utility power failure. No overload is permitted on these ratings. The alternators on these models are peak continuous rated (as defined in ISO 8523-3) at 25° C (77° F).

**Prime** — These ratings are applicable for supplying continuous electrical power (at variable load) in lieu of commercially purchased power. There is no limitation to the annual hours of operation and models can supply 10% overload power for 1 hour in 12 hours.

**Olympian Generator Sets**  
**Outside North America Diesel Ratings**

Model	60 Hz			50 Hz		
	rpm	Standby	Prime	rpm	Standby	Prime
		ekW			kVA	
<b>Single Phase Output*</b>						
GEP7.5SP	—	—	—	1500	7.5	6.8
GEP11SP	1800	13	12	1500	11	10
GEP14SP	1800	17	15.5	1500	14	13
GEP16SP	1800	20	18	1500	16.5	15
GEP26SP	—	—	—	1500	26	24
GEP35SP	1800	40	36	1500	35	32
GEP50SP	1800	55	50	1500	50	45
GEP80SP	1800	90	82	1500	80	72

\*Ratings at 1.0 pf and 25° C (77° F).

**Rating Definitions:**

**Standby** — These ratings are applicable for supplying continuous power (at variable load) in the event of a utility power failure. No overload is permitted on these ratings. The alternators on these models are peak continuous rated (as defined in ISO 8523-3) at 25° C (77° F).

**Prime** — These ratings are applicable for supplying continuous electrical power (at variable load) in lieu of commercially purchased power. There is no limitation to the annual hours of operation and models can supply 10% overload power for 1 hour in 12 hours.

**Diesel Power Module Rating**

50 Hz			
Model	rpm	Standby	Prime
		kVA	
<b>3-Phase Output</b>			
XQE20	1500	—	20
XQE30	1500	—	30
XQE60	1500	—	60
XQE80	1500	—	80
XQE100	1500	—	100
XQE150	1500	—	150
XQE200	1500	—	200
XQE250	1500	—	250

60 Hz			
Model	rpm	Standby	Prime
		ekW	
XQ20	1800	20	18
XQ30	1800	30	27
XQ45	1800	45	41
XQ60	1800	60	54
XQ80	1800	80	70
XQ100	1800	100	90
XQ230	1800	230	210
XQ300	1800	300	275
XQ400	1800	400	365
XQ600	1800	600	545
XQ1000	1800	1000	910

**Rating Definitions:**

**Standby** — Applicable for supplying continuous electrical power (at variable load) in the event of a utility power failure. No overload is permitted on these ratings.

**Prime** — These ratings are applicable for supplying continuous electrical power (at variable load) in lieu of commercially purchased power. There is no limitation to the annual hours of operation and this model can supply 10 percent overload power for 1 hour in 12 hours.

- Olympian Generator Sets
- North America Gas Ratings
  - Outside North America Gas Ratings

Olympian Generator Sets

North America Gas Ratings (Standard)

60 Hz			
Model	rpm	Standby	
		ekW	
		LP	Natural
<b>Single Phase &amp; 3-Phase Output</b>			
G25LTA	1800	25	25
G55LTA	1800	55	55
G70LTA	1800	70	70
G80LTA	2650	80	80
G100LTA	2300	100	100
G130LTA	3000	130	130
G150LTA	3600	150	150

North America Gas Ratings (Customizable)

60 Hz			
Model	rpm	Standby	
		ekW	
		LP	Natural
<b>Single Phase &amp; 3-Phase Output</b>			
G35LG	1800	35	35
G40LG	1800	40	40
G45LG	1800	45	45
G50LG	1800	50	50
G60LG	1800	60	60
G70LG	1800	70	70
G80LG	2300	80	80
G100LG	2300	100	100
G130LG	3000	130	130
G150LG	3600	150	150
G175LG	1800	175	175
G200LG	1800	200	200
G230LG	2300	230	230
G250LG	2300	250	250
G275LG	2300	275	275
G300LG	2300	300	300

Outside North America Gas Ratings

60 Hz					
Model	rpm	Standby		Prime	
		ekW		ekW	
		LP	Natural	LP	Natural
<b>3-Phase Output*</b>					
GEUG16-1	1800	16	15	13.5	13.5
GEUHG30-1	3600	25	25	—	—
<b>Single Phase Output**</b>					
GEUG13S1	1800	16	15	13.5	13
GEUHG24S1	3600	25	25	—	—
50 Hz					
Model	rpm	Standby		Prime	
		kVA		kVA	
		LP	Natural	LP	Natural
<b>3-Phase Output*</b>					
GEUG16-1	1500	16.5	15	14	12.5
GEUHG30-1	3000	30	30	—	—
<b>Single Phase Output**</b>					
GEUG13S1	1500	13	11.8	11	10
GEUHG24S1	3000	24	24	—	—

\*Ratings at 0.8 pf and 43° C (100° F).

\*\*Ratings at 1.0 pf and 32° C (90° F).

Rating Definitions:

**Standby** — These ratings are applicable for supplying continuous electrical power (at variable load) in the event of a utility power failure. No overload is permitted on these ratings. Natural gas ratings have been established on natural gas with net calorific value of approximately 36.8 mJ/m<sup>3</sup> (988 Btu/ft<sup>3</sup>).

**Prime** — These ratings are applicable for supplying continuous electrical power (at variable load) in lieu of commercially purchased power. There is no limitation to the annual hours of operation and this model can supply 10 percent overload power for 1 hour in 12 hours.

## Cat Generator Sets

## Gas Ratings

Model	60 Hz	
	Standby	Continuous
	ekW	
	1800 rpm	
G3306	—	85
G3306	—	100
G3306	—	135
G3306	—	140
G3406	150	150
G3406	240	190
G3406	260	—
G3406	275	—
G3412	350	—
G3412C	375	—
G3412	410	350
G3412	435	—
G3412	445	—
G3412C	450	375
G3412	460	—
G3412	470	—
G3412	480	—
G3412	495	—
G3412	515	—
G3516	1040	—
G3516B	—	1300
G3516B	—	1400
G3516C	—	1660
G3520C	—	1900
G3520C	—	2055

## Rating Definitions:

**Standby** — These ratings are applicable for supplying continuous electrical power (at variable load) in the event of a utility power failure. No overload is permitted on these ratings. Natural gas ratings have been established on natural gas with net calorific Low Heat Value (LHV) of approximately 36.2 mJ/m<sup>3</sup> (**920 Btu/ft<sup>3</sup>**).

**Continuous** — Output available without varying load for an unlimited time. Continuous power in accordance with ISO 8528, ISO 3046/1, AS2789, DIN6271, and BS5514. Natural gas ratings have been established on natural gas with net calorific Low Heat Value (LHV) of approximately 36.2 mJ/m<sup>3</sup> (**920 Btu/ft<sup>3</sup>**).

Model	60 Hz	
	Standby	Continuous
	ekW	
	1200 rpm	
G3508	—	360
G3508	—	370
G3508	—	375
G3508	—	380
G3508	—	385
G3508	—	390
G3508	—	400
G3512	—	555
G3512	—	560
G3512	—	570
G3512	—	585
G3512	—	600
G3516	—	695
G3516	—	735
G3516	—	750
G3516	—	755
G3516	—	770
G3516	—	795
G3516	—	815
G3516	—	820
G3520C	—	1600
	900 rpm	
G3606	—	1155
G3606	—	1235
G3608	—	1540
G3608	—	1640
G3612	—	2310
G3612	—	2335
G3612	—	2315
G3612	—	2465
G3612	—	2595
G3612	—	2615
G3616	—	3080
G3616	—	3105
G3616	—	3408
G3616	—	3480
	720 rpm	
G16CM34	—	6520

## Cat Generator Sets

### Gas Ratings

Model	50 Hz	
	Continuous	
	kVA	ekW
	1500 rpm	
G3306	80	64
G3306	83	66
G3306	87	70
G3306	106	85
G3406	129	103
G3406	133	106
G3306	138	110
G3306	156	125
G3406	156	125
G3406	200	160
G3412	204	163
G3412	215	172
G3412	350	280
G3412	450	360
G3508	600	480
G3508	619	495
G3508	631	505
G3508	637	510
G3512	906	725
G3512	931	745
G3512	956	765
G3512	963	770
G3512E	1200	1000
G3516	1218	974
G3516	1287	1030
G3516B	1356	1085
G3516B	1380	1104
G3516B	1388	1110
G3516B	1431	1145
G3516B	1456	1165
G3512E	1500	1200
G3516C	1944	1555
G3516C	1975	1580
G3516C	1986	1589
G3516E	2000	1600
G3520C	2438	1950
G3520C	2458	1966
G3520C	2500	2000
G3520E	2500	2000

Model	50 Hz	
	Continuous	
	kVA	ekW
	1000 rpm	
G3606	1606	1285
G3606	1712	1370
G3608	2143	1714
G3608	2281	1825
G3612	3212	2570
G3612	3425	2740
G3612	3593	2874
G3612	3625	2900
G3616	4281	3425
G3616	4562	3650
G3616	4825	3860
	750 rpm	
G16CM34	8150	6520

#### Rating Definitions:

**Standby** — These ratings are applicable for supplying continuous electrical power (at variable load) in the event of a utility power failure. No overload is permitted on these ratings. Natural gas ratings have been established on natural gas with net calorific Low Heat Value (LHV) of approximately 36.2 mJ/m<sup>3</sup> (920 Btu/ft<sup>3</sup>).

**Continuous** — Output available without varying load for an unlimited time. Continuous power in accordance with ISO 8528, ISO 3046/1, AS2789, DIN6271, and BS5514. Natural gas ratings have been established on natural gas with net calorific Low Heat Value (LHV) of approximately 36.2 mJ/m<sup>3</sup> (920 Btu/ft<sup>3</sup>).



**MaK Marine Generator Sets**
**Medium Speed Ratings**

MaK Model	Output range	Output range	Output range	Frequency	Speed	Bore	Stroke
	kW	ekW	kVA	Hz	rpm	mm	mm
<b>6 M 20 C</b>	1020/1140	970/1080	1210/1355	60/50	900/1000	200	300
<b>8 M 20 C</b>	1360/1520	1290/1445	1615/1805	60/50	900/1000	200	300
<b>9 M 20 C</b>	1530/1710	1450/1625	1820/2030	60/50	900/1000	200	300
<b>6 M 25 C</b>	1800/1900	1710/1800	2140/2250	60	720	255	400
	1850/2000	1760/1900	2200/2380	50	750	255	400
<b>8 M 25 C</b>	2320/2540	2200/2400	2750/3000	60	720	255	400
	2400/2660	2280/2530	2850/3160	50	750	255	400
<b>9 M 25 C</b>	2610/2850	2480/2700	3100/3370	60	720	255	400
	2700/3000	2570/2850	3210/3560	50	750	255	400
<b>6 M 32 C</b>	2880/3000	2765/2880	3456/3600*	60/50	600	320	480
<b>8 M 32 C</b>	3840/4000	3686/3840	4608/4800*	60/50	600	320	480
<b>9 M 32 C</b>	4320/4500	4147/4320	5184/5400*	60/50	600	320	480
<b>12 M 32 C</b>	5760/6000	5530/5760	6912/7200*	60/50	720/750	320	420
<b>16 M 32 C</b>	7680/8000	7373/7680	9216/9600*	60/50	720/750	320	420

Generator efficiency: 0.95, cos  $\phi$  0.8.

\*Generator efficiency: 0.96, cos  $\phi$  0.8.

ekW — Electrical Kilowatts = kVA  $\times$  0.8 pf

## Cat Generator Sets

### Diesel Ratings

60 Hz			
Model	rpm	Standby	Prime
		ekW	
<b>3-Phase Output*</b>			
D13	1800	13	12
D20	1800	20	18
D25	1800	25	22.8
D30	1800	30	27
D40	1800	40	36
D50	1800	50	45
D60	1800	60	54.6
D80	1800	80	72
D100	1800	100	90
D125	1800	125	114
D150	1800	150	135
D175	1800	175	157.5
<b>Single Phase Output**</b>			
D13S	1800	13	11.8
D20S	1800	20	18
D25S	1800	25	22.5
D30S	1800	30	27
D40S	1800	40	36
D50S	1800	50	45
D60S	1800	60	55
D80S	1800	80	72
D100S	1800	100	90

\*All ratings at 0.8 pf.

\*\*All ratings at 1.0 pf.

#### Rating Definitions:

**Emergency Standby Power (ESP)** — Output available with varying load for the duration of an emergency outage. Average power output is 70% of the standby power rating. Typical operation is 50 hours per year, with maximum expected usage of 200 hours per year. Standby power in accordance with ISO8528. Fuel stop power in accordance with ISO3046. Standby ambients shown indicate ambient temperature at 100% load which results in a coolant top tank temperature just below the shutdown temperature.

**Standby Power Rating** — Output available with varying load for the duration of the interruption of the normal source power. Average power output is 70% of the standby power rating. Typical operation is 200 hours per year, with maximum expected usage of 500 hours per year.

Standby power in accordance with ISO3046. Standby ambients shown indicate ambient temperature at 100% load which results in a coolant top tank temperature just below the shutdown temperature.

**Prime Power Rating** — Output available with varying load for an unlimited time. Average power output is 70% of the prime power rating. Typical peak demand is 100% of prime rated kW with 10% overload capability for emergency use for a maximum of 1 hour in 12. Overload operation cannot exceed 25 hours per year. Prime power in accordance with ISO3046.

60 Hz			
Model	Standby	Prime	Continuous
	ekW		
<b>1800 rpm</b>			
C9 ACERT	200	180	—
C9 ACERT	250	225	—
C9 ACERT	300	275	—
C15 ACERT	350	320	—
C15 ACERT	400	365	—
C15 ACERT	450	410	—
C15 ACERT	500	455	—
C15 ACERT*	550	—	—
C18 ACERT	550	500	—
C18 ACERT	600	545	—
C27 ACERT	650	591	—
C27 ACERT	700	635	—
C27 ACERT	750	680	—
C27 ACERT	800	725	—
C32 ACERT	1000	910	830
3512	1100	1000	890
3512	1250	1135	1010
3512B	1400	1275	1230
3512C	1500	1360	1230
3516	1750	1600	1450
3516C	1750	—	1650
3516C	2000	1825	1640
3516B	2250	—	—
3516C-HD	2500	2250	2050
3608	2660	2420	—
C175-16	3000	2725	2500
C175-16	3100	2825	2600
3612	4000	3640	3300
3616	5320	4840	4400

\*ESP — Emergency Standby.

Prime ambients shown indicate ambient temperature at 100% load which results in a coolant top tank temperature just below the alarm temperature.

**Continuous Power Rating** — Output available with non-varying load for an unlimited time. Average power output is 70-100% of the continuous power rating. Typical peak demand is 100% of continuous rated kW for 100% of operating hours. Continuous power in accordance with ISO3046.

Continuous ambients shown indicate ambient temperature at 100% load which results in a coolant top tank temperature below the alarm temperature.

**Meets or Exceeds International Specifications: AS1359, CSA, IEC60034-1, ISO3046, ISO8528, NEMA MG 1-22, NEMA MG 1-33, UL508A, 72/23/EEC, 98/37/EC, 2004/108/EC.**

**Fuel rates** are based on fuel oil of 35° API [16° C (60° F)] gravity having an LHV of 42 780 kJ/kg (18,390 Btu/lb) when used at 29° C (85° F) and weighing 838.9 g/liter (7.001 lb/U.S. gal.). Additional ratings may be available for specific customer requirements, contact your Caterpillar representative for details. For information regarding Low Sulfur fuel and Biodiesel capability, please consult your Cat dealer.

## Cat Generator Sets

## Diesel Ratings

60 Hz			
Model	Standby	Prime	Continuous
	ekW		
<b>900 rpm</b>			
3606	2000	1820	1650
3608	2660	2420	2200
3612	4000	3640	3300
3616	5320	4840	4400
<b>720 rpm</b>			
3606	1680	1525	1375
3608	2200	2020	1830
3612	3360	3050	2750
3616	4440	4040	3660
12CM32	—	—	5590
16CM32	—	—	7450
<b>600 rpm</b>			
6CM32	—	—	2765
8CM32	—	—	3725
9CM32	—	—	4190
<b>514 rpm</b>			
6CM43	—	—	5240
7CM43	—	—	6110
8CM43	—	—	6980
9CM43	—	—	7860
12CM43	—	—	10 475
16CM43	—	—	13 970

## Rating Definitions:

**Emergency Standby Power (ESP)** — Output available with varying load for the duration of an emergency outage. Average power output is 70% of the standby power rating. Typical operation is 50 hours per year, with maximum expected usage of 200 hours per year. Standby power in accordance with ISO8528. Fuel stop power in accordance with ISO3046. Standby ambients shown indicate ambient temperature at 100% load which results in a coolant top tank temperature just below the shutdown temperature.

**Standby Power Rating** — Output available with varying load for the duration of the interruption of the normal source power. Average power output is 70% of the standby power rating. Typical operation is 200 hours per year, with maximum expected usage of 500 hours per year.

Standby power in accordance with ISO8528. Fuel stop power in accordance with ISO3046. Standby ambients shown indicate ambient temperature at 100% load which results in a coolant top tank temperature just below the shutdown temperature.

**Prime Power Rating** — Output available with varying load for an unlimited time. Average power output is 70% of the prime power rating. Typical peak demand is 100% of prime rated ekW with 10% overload capability for emergency use for a maximum of 1 hour in 12. Overload operation cannot exceed 25 hours per year. Prime power in accordance with ISO3046.

Prime ambients shown indicate ambient temperature at 100% load which results in a coolant top tank temperature just below the alarm temperature.

**Continuous Power Rating** — Output available with non-varying load for an unlimited time. Average power output is 70-100% of the continuous power rating. Typical peak demand is 100% of continuous rated ekW for 100% of operating hours. Continuous power in accordance with ISO3046.

Continuous ambients shown indicate ambient temperature at 100% load which results in a coolant top tank temperature below the alarm temperature.

**Meets or Exceeds International Specifications: AS1359, CSA, IEC60034-1, ISO3046, ISO8528, NEMA MG 1-22, NEMA MG 1-33, UL508A, 72/23/EEC, 98/37/EC, 2004/108/EC.**

**Fuel rates** are based on fuel oil of 35° API [16° C (60° F)] gravity having an LHV of 42 780 kJ/kg (18,390 Btu/lb) when used at 29° C (85° F) and weighing 838.9 g/liter (7.001 lb/U.S. gal.). Additional ratings may be available for specific customer requirements, contact your Caterpillar representative for details. For information regarding Low Sulfur fuel and Biodiesel capability, please consult your Cat dealer.

Cat Generator Sets

Diesel Ratings

50 Hz			
Model	Standby	Prime	Continuous
	kVA		
1500 rpm			
3406C	300	275	—
3406C	350	320	—
3406C	400	365	—
C15 ACERT	400	365	—
C15 ACERT	450	410	—
C15 ACERT	500	455	—
C15 ACERT	550	500	—
C18 ACERT	550	500	—
C18 ACERT	605	550	—
C18 ACERT	650	591	—
C18 ACERT	660	600	—
C18 ACERT	700	635	—
3412C	750	680	—
3412C	800	725	—
3412C	900	810	—
C32 ACERT	1100	1000	910
3512	1250	1150	1000
3512B	1400	1275	1206
3512B	1500	1360	1320
3512B	1600	1450	—
3512B	1600	1500	—
3512B-HD	1750	1600	1500
3512B-HD	1875	1700	—
3516	2000	1825	1600
3516B	2250	2000	1750
3516B-HD	2500	2275	2000
C175-16	3000	2725	2500
C175-16	3100*	2825*	2600*

\*Rating does not include package mounted radiator.

Rating Definitions:

**Emergency Standby Power (ESP)** — Output available with varying load for the duration of an emergency outage. Average power output is 70% of the standby power rating. Typical operation is 50 hours per year, with maximum expected usage of 200 hours per year. Standby power in accordance with ISO8528. Fuel stop power in accordance with ISO3046. Standby ambients shown indicate ambient temperature at 100% load which results in a coolant top tank temperature just below the shutdown temperature.

**Standby Power Rating** — Output available with varying load for the duration of the interruption of the normal source power. Average power output is 70% of the standby power rating. Typical operation is 200 hours per year, with maximum expected usage of 500 hours per year.

Standby power in accordance with ISO8528. Fuel stop power in accordance with ISO3046. Standby ambients shown indicate ambient temperature at 100% load which results in a coolant top tank temperature just below the shutdown temperature.

**Prime Power Rating** — Output available with varying load for an unlimited time. Average power output is 70% of the prime power rating. Typical peak demand is 100% of prime rated kW with 10% overload capability for emergency use for a maximum of 1 hour in 12. Overload operation cannot exceed 25 hours per year. Prime power in accordance with ISO3046.

Prime ambients shown indicate ambient temperature at 100% load which results in a coolant top tank temperature just below the alarm temperature.

**Continuous Power Rating** — Output available with non-varying load for an unlimited time. Average power output is 70-100% of the continuous power rating. Typical peak demand is 100% of continuous rated kW for 100% of operating hours. Continuous power in accordance with ISO3046.

Continuous ambients shown indicate ambient temperature at 100% load which results in a coolant top tank temperature below the alarm temperature.

**Meets or Exceeds International Specifications: AS1359, CSA, IEC60034-1, ISO3046, ISO8528, NEMA MG 1-22, NEMA MG 1-33, UL508A, 72/23/EEC, 98/37/EC, 2004/108/EC.**

**Fuel rates** are based on fuel oil of 35° API [16° C (60° F)] gravity having an LHV of 42 780 kJ/kg (18,390 Btu/lb) when used at 29° C (85° F) and weighing 838.9 g/liter (7.001 lb/U.S. gal.). Additional ratings may be available for specific customer requirements, contact your Caterpillar representative for details. For information regarding Low Sulfur fuel and Biodiesel capability, please consult your Cat dealer.

## Cat Generator Sets

## Diesel Ratings

50 Hz			
Model	Standby	Prime	Continuous
	kVA		
<b>1000 rpm</b>			
3606	2688	2425	2200
3608	3575	3250	2938
3612	5375	4850	4400
3616	7150	6500	5875
<b>750 rpm</b>			
3606	2163	1963	1775
3608	2863	2600	2363
3612	4325	3925	3550
3616	5725	5200	4725
12CM32	—	—	6988
16CM32	—	—	9313
<b>600 rpm</b>			
6CM32	—	—	3456
8CM32	—	—	4656
9CM32	—	—	5238
<b>500 rpm</b>			
6CM43	—	—	6550
7CM43	—	—	7638
8CM43	—	—	8725
9CM43	—	—	9825
12CM43	—	—	13 094
16CM43	—	—	17 463

## Rating Definitions:

**Emergency Standby Power (ESP)** — Output available with varying load for the duration of an emergency outage. Average power output is 70% of the standby power rating. Typical operation is 50 hours per year, with maximum expected usage of 200 hours per year. Standby power in accordance with ISO8528. Fuel stop power in accordance with ISO3046. Standby ambients shown indicate ambient temperature at 100% load which results in a coolant top tank temperature just below the shutdown temperature.

**Standby Power Rating** — Output available with varying load for the duration of the interruption of the normal source power. Average power output is 70% of the standby power rating. Typical operation is 200 hours per year, with maximum expected usage of 500 hours per year.

Standby power in accordance with ISO8528. Fuel stop power in accordance with ISO3046. Standby ambients shown indicate ambient temperature at 100% load which results in a coolant top tank temperature just below the shutdown temperature.

**Prime Power Rating** — Output available with varying load for an unlimited time. Average power output is 70% of the prime power rating. Typical peak demand is 100% of prime rated kW with 10% overload capability for emergency use for a maximum of 1 hour in 12. Overload operation cannot exceed 25 hours per year. Prime power in accordance with ISO3046.

Prime ambients shown indicate ambient temperature at 100% load which results in a coolant top tank temperature just below the alarm temperature.

**Continuous Power Rating** — Output available with non-varying load for an unlimited time. Average power output is 70-100% of the continuous power rating. Typical peak demand is 100% of continuous rated kW for 100% of operating hours. Continuous power in accordance with ISO3046.

Continuous ambients shown indicate ambient temperature at 100% load which results in a coolant top tank temperature below the alarm temperature.

**Meets or Exceeds International Specifications: AS1359, CSA, IEC60034-1, ISO3046, ISO8528, NEMA MG 1-22, NEMA MG 1-33, UL508A, 72/23/EEC, 98/37/EC, 2004/108/EC.**

**Fuel rates** are based on fuel oil of 35° API [16° C (60° F)] gravity having an LHV of 42 780 kJ/kg (18,390 Btu/lb) when used at 29° C (85° F) and weighing 838.9 g/liter (7.001 lb/U.S. gal.). Additional ratings may be available for specific customer requirements, contact your Caterpillar representative for details. For information regarding Low Sulfur fuel and Biodiesel capability, please consult your Cat dealer.

## Cat Marine Engines

### Propulsion Ratings

Engine Model	bkW Rating Range	mhp Rating Range
C280-16 DITA	4600-5420	6169-7268
C280-12 DITA	3460-4060	4640-5444
C280-8 DITA	2300-2710	3084-3634
C280-6 DITA	1730-2030	2320-2722
3516C DITA	2350-2525	3151-3386
3516B HP DITA	2000-2237	2682-3000
3516B HD DITA	1398-2000	1875-2682
3516B DITA	1230-1640	1650-2200
3516 DITA	1195-1640	1603-2200
3512C DITA	1765-1895	2367-2541
3512B HP DITA	1342-1678	1800-2250
3512B HD DITA	1118-1500	1500-2012
3512B DITA	820-1230	1100-1650
3512 DITA	900-1305	1207-1750
3508B HP DITA	895-1118	1200-1500
3508B DITA	578-820	775-1100
3508 DITA	526-857	705-1150
C32 DITA	820-1232	1100-1652
C32 ACERT DITA	1343	1800
C18 DITTA	651-747	873-1001
C18 DITA	339-533	454-715
C15 ACERT DITA	597-636	800-853
C12 DITA	254-448	340-600
C12 ACERT DITA	492-526	660-705
C9 ACERT DITA	375-423	503-567
C7 DITA	187-276	250-370
C7 ACERT DITA	339	455
3056 DITA	138-153	185-205
3056 DINA	93	125

### Generator Ratings

Engine Model	50 Hz ekW @ rpm	60 Hz ekW @ rpm
C280-16 DITA	4700/5200 @ 1000	4400/4840 @ 900
C280-12 DITA	3520/3880 @ 1000	3300/3640 @ 900
C280-8 DITA	2350/2600 @ 1000	2200/2420 @ 900
C280-6 DITA	1760/1940 @ 1000	1650/1825 @ 900
3516B DITA	1460/1600 @ 1500	1825 @ 1800
3516B DITA	1180 @ 1000	1285 @ 1200
3512B DITA	965/1200 @ 1500	1070/1360 @ 1800
3512B DITA	880 @ 1000	1030 @ 1200
3508B DITA	630/800 @ 1500	715/910 @ 1800
3508B DITA	590 @ 1000	600 @ 1200
3412C DITA	350-500 @ 1500	400-590 @ 1800
C18 DITA	275-450 @ 1500	340-425 @ 1800
C18 DITTA	—	500-550 @ 1800
3406C DITA	200-245 @ 1500	250-320 @ 1800
C9 DITA	150-200 @ 1500	175-250 @ 1800
C4.4 DIT	65-86 @ 1500	72 @ 1800
C2.2 DINA	17.5/18 @ 1500	21/21.5 @ 1800
C1.5 DINA	11/12 @ 1500	14.5/13.5 @ 1800

**For more information on IMO regulations and compliance contact:**

- IMO headquarters for “Annex VI of MARPOL 73/78...” London, phone: 011-44 (0) 171-735-7611
- EPA paper “Frequently Asked Questions about MARPOL 73/78...” download from web site: [epa.gov/oms/marine.htm](http://epa.gov/oms/marine.htm) or call Michigan: (734) 214-4822
- ABS guide “Notes on Prevention of Air Pollution from Ships,” Texas, phone: (281) 877-6306, fax: (281) 877-5801, e-mail: [jpatterson@eagle.org](mailto:jpatterson@eagle.org)

For additional information on Cat Marine Power, see our new marine site: [www.cat-marine.com](http://www.cat-marine.com)

# Engines

## MaK Marine Engines

- Propulsion Ratings
- Generator Ratings

### MaK Marine Engines

#### Propulsion Ratings

MaK Model	kW Rating Range	mhp Rating Range
6 M 20 C	1020	1390
	1140	1550
8 M 20 C	1360	1850
	1520	2070
9 M 20 C	1530	2080
	1710	2325
6 M 25 C	1800	2450
	1900	2585
	1850	2525
	2000	2720
8 M 25 C	2320	3155
	2540	3455
	2400	3265
	2660	3620
9 M 25 C	2610	3550
	2850	3875
	2700	3670
	3000	4080
6 M 32 C	2880	3915
	3000	4080
8 M 32 C	3840	5220
	4000	5440
9 M 32 C	4320	5875
	4500	6120
12 M 32 C	5760	7835
	6000	8160
16 M 32 C	7680	10,445
	8000	10,880
6 M 43 C	5400	7340
	5400	7340
	6000	8160
	6000	8160
7 M 43 C	6300	8570
	6300	8570
	7000	9520
	7000	9520

#### Propulsion Ratings

MaK Model	kW Rating Range	mhp Rating Range
8 M 43 C	7200	9790
	7200	9790
	8000	10,880
	8000	10,880
9 M 43 C	8100	11,015
	8100	11,015
	9000	12,240
	9000	12,240
12 M 43 C	10 800	14,690
	10 800	14,690
	12 000	16,320
	12 000	16,320
16 M 43 C	14 400	19,585
	14 400	19,585
	16 000	21,760
	16 000	21,760

#### Generator Ratings

MaK Model	50 Hz ekW @ rpm	60 Hz ekW @ rpm
6 M 20 C	1080 @ 1000	970 @ 900
8 M 20 C	1445 @ 1000	1290 @ 900
9 M 20 C	1625 @ 1000	1450 @ 900
6 M 25 C	1760/1900 @ 750	1710/1800 @ 720
8 M 25 C	2280/2530 @ 750	2200/2400 @ 720
9 M 25 C	2570/2850 @ 750	2480/2700 @ 720
6 M 32 C	2765/2880 @ 600	2765/2880 @ 600
8 M 32 C	3686/3840 @ 600	3686/3840 @ 600
9 M 32 C	4147/4320 @ 600	4147/4320 @ 600
12 M 32 C	5760 @ 750	5530 @ 720
16 M 32 C	7680 @ 750	7373 @ 720

## Cat Marine Engines

### Auxiliary Ratings

Engine Model	bkW/bhp				
C280-16 DITA	4600-5420/6169-7268				
C280-12 DITA	3460-4060/4640-5444				
C280-8 DITA	2300-2710/3084-3634				
C280-6 DITA	1730-2030/2320-2722				
Engine Model	50 Hz 1500 rpm bkW/bhp	50 Hz 1000 rpm bkW/bhp	60 Hz 1800 rpm bkW/bhp	60 Hz 1200 rpm bkW/bhp	60 Hz 900 rpm bkW/bhp
C280-16 DITA	—	4920-5420/ 6598-7268	—	—	4600-5060/ 6169-6785
C280-12 DITA	—	3700-4060/ 4962-5444	—	—	3460-3800/ 4640-5096
C280-8 DITA	—	2460-2710/ 3299-3634	—	—	2300-2530/ 3084-3393
C280-6 DITA	—	1850-2030/ 2481-2722	—	—	1730-1900/ 2320-2548
3516C DITA	—	—	2095-2350/ 2809-3151	—	—
3512C DITA	—	—	1628-1786/ 2183-2394	—	—
3516B DITA	1566-1717/ 2100-2303	1287/ 1726	1901/ 2549	1383/ 1855	—
3512B DITA	1020-1257/ 1368-1686	933/ 1251	1125-1424/ 1509-1910	1102/ 1478	—
3508B DITA	673-856/903-1148	649/870	760-968/1019-1298	682/915	—
3516 DITA	1355/1817	1100/1475	1511/2026	1230/1650	—
3512 DITA	1020/1368	860/1153	1125/1509	955/1281	—
3508 DITA	673/903	446/598	760/1019	599/804	—
3412C DITA (R)	413-513/ 554-688	—	427-583/573-782	—	—
3408C DITA (R)	332/445	—	396/531	—	—
3406C DITA (R)	224-254/ 300-341	—	267-336/ 358-451	—	—
3412C DITA (HE)	431-534/578-716	—	450-620/603-831	—	—
3408C DITA (HE)	340/456	—	410/550	—	—
3406C DITA (HE)	229-260/307-349	—	228-345/306-462	—	—
C18 DITA	—	—	547-601/ 733-806	—	—
C18 DITA	301-492/ 404-660	—	372-465/ 499-624	—	—
C9 DITA	162-215/ 217-288	—	189-269/ 253-361	—	—

**For more information on  
IMO regulations and compliance contact:**

- IMO headquarters for "Annex VI of MARPOL 73/78..."  
London, phone: 011-44 (0) 171-735-7611
- EPA paper "Frequently Asked Questions about MARPOL 73/78..." download from web site: [epa.gov/oms/marine.htm](http://epa.gov/oms/marine.htm)  
or call Michigan: (734) 214-4822
- ABS guide "Notes on Prevention of Air Pollution from Ships,"  
Texas, phone: (281) 877-6306, fax: (281) 877-5801,  
e-mail: [jpatterson@eagle.org](mailto:jpatterson@eagle.org)

**For additional information on Cat Marine Power,  
see our new marine site: [www.cat-marine.com](http://www.cat-marine.com)**



## Cat Industrial Diesel Applications

Model	Type	“IND A”			“IND B”			“IND C”			“IND D”			“IND E”		
		bkW	bhp	rpm	bkW	bhp	rpm	bkW	bhp	rpm	bkW	bhp	rpm	bkW	bhp	rpm
C0.5	NA	—	—	—	—	—	—	8.2	11.0	2800	—	—	—	—	—	—
		—	—	—	—	—	—	10.2	13.7	3600	—	—	—	—	—	—
C0.7	NA	—	—	—	—	—	—	12.2	16.3	2800	—	—	—	—	—	—
		—	—	—	—	—	—	15.3	20.5	3600	—	—	—	—	—	—
C1.1	NA	—	—	—	—	—	—	14.7/13.7	19.7/18.3	2200	—	—	—	—	—	—
		—	—	—	—	—	—	16.1/14.6	21.6/19.6	2400	—	—	—	—	—	—
		—	—	—	—	—	—	17.3/15.8	23.2/21.2	2600	—	—	—	—	—	—
		—	—	—	—	—	—	18.5/16.8	24.8/22.5	2800	—	—	—	—	—	—
		—	—	—	—	—	—	19.7/17.7	26.4/23.7	3000	—	—	—	—	—	—
		—	—	—	—	—	—	21.0	28.2	3400	—	—	—	—	—	—
C1.5	NA	—	—	—	—	—	—	20.7	27.8	2200	—	—	—	—	—	—
		—	—	—	—	—	—	22.3	29.9	2400	—	—	—	—	—	—
		—	—	—	—	—	—	23.4	31.4	2600	—	—	—	—	—	—
		—	—	—	—	—	—	24.4	32.7	2800	—	—	—	—	—	—
		—	—	—	—	—	—	25.1	33.7	3000	—	—	—	—	—	—
C1.5	T	—	—	—	—	—	—	23.1	31.0	2200	—	—	—	—	—	—
		—	—	—	—	—	—	25.2	33.8	2400	—	—	—	—	—	—
		—	—	—	—	—	—	27.3	36.6	2600	—	—	—	—	—	—
		—	—	—	—	—	—	29.4	39.4	2800	—	—	—	—	—	—
		—	—	—	—	—	—	30.0	40.2	3000	—	—	—	—	—	—
C1.6	NA	—	—	—	—	—	—	24.6	33.0	2800	—	—	—	—	—	—
		—	—	—	—	—	—	26.5	35.5	3000	—	—	—	—	—	—
C1.7	NA	—	—	—	—	—	—	24.7	33.2	2400	—	—	—	—	—	—
		—	—	—	—	—	—	26.0	34.8	2600	—	—	—	—	—	—

C0.5, C0.7, C1.1, C1.5, C1.6, C1.7 — Meets Tier 2, Stage II emissions requirements. Designed to meet Tier 3, Stage IIIA and Tier 4, Stage IIIB emissions requirements. Tier 2, Tier 3, and Tier 4 refer to EPA (U.S.) requirements. Stage IIIA and Stage IIIB refer to European requirements.

**Rating Definitions:**

**NOTE:** Application examples are for reference only. For an exact determination of the appropriate rating, contact the factory or your local Cat dealer.

**Rating Conditions:****Diesel Engines — up to 6.6 liter**

All rating conditions are based on ISO/TR14396, inlet air standard conditions with a total barometric pressure of 100 kPa (29.5 in Hg), with a vapor pressure of 1 kPa (0.295 in Hg), and 25° C (77° F). Performance measured using fuel to specification EPA 2D 89.330-96 with a density of 0.845-0.850 kg/L @ 15° C (59° F) and fuel inlet temperature 40° C (104° F).

**Diesel Engines — 7 liter and higher**

All rating conditions are based on SAE J1995, inlet air standard conditions of 99 kPa (29.31 in Hg) dry barometer and 25° C (77° F) temperature. Performance measured using a standard fuel with fuel gravity of 35° API having a lower heating value of 42,780 kJ/kg (18,390 btu/lb) when used at 29° C (84.2° F) with a density of 838.9 g/L.

**Gas Engines**

Ratings are based on SAE J1349 standard conditions of 100 kPa (29.61 in Hg) and 25° C (77° F). These ratings also apply at ISO3046, DIN6271, and BS5514 standard conditions of 100 kPa (29.61 in Hg) and 27° C (81° F); and API 7B-11C standard conditions of 99 kPa (29.28 in Hg) and 29° C (85° F) also apply.

Ratings are based on dry natural gas having an LHV of 35.54 MJ/N·m<sup>3</sup> (905 btu/ft<sup>3</sup>). Variations in altitude, temperature, and gas composition from standard conditions may require a reduction in engine horsepower. Turbocharged-Aftercooled ratings apply to 1525 m (5000 ft) and 25° C (77° F).

**A Rating (Continuous):**

- For heavy-duty services when engine is operated at rated load and speed up to 100% of the time without interruption or load cycling.
- Time at full load up to 100% of the duty cycle.

**B Rating:**

- For service where power and/or speed are cyclic.
- Time at full load not to exceed 80% of the duty cycle.

**C Rating (Intermittent):**

- For intermittent service where maximum power and/or speed are cyclic.
- Time at full load not to exceed 50% of the duty cycle.

**D Rating:**

- For service where maximum power is required for periodic overloads.
- Time at full load not to exceed 10% of the duty cycle.

**E Rating:**

- For service where rated power is required for a short time for initial starting or sudden overload. For emergency service where standard power is unavailable.
- Time at full load not to exceed 5% of the duty cycle.

NA — Naturally Aspirated  
T — Turbocharged  
TA — Turbocharged-Aftercooled  
ATAAC — Air-to-Air Aftercooled  
DI — Direct Injection  
PC — Precombustion Chamber (Indirect Injection)  
hp — Horsepower  
kW — Metric equivalent of horsepower

Cat Industrial Diesel Applications

Model	Type	"IND A"			"IND B"			"IND C"			"IND D"			"IND E"		
		bkW	bhp	rpm	bkW	bhp	rpm	bkW	bhp	rpm	bkW	bhp	rpm	bkW	bhp	rpm
C2.2	NA	—	—	—	—	—	—	31.0/27.5	<b>41.6/36.9</b>	2200	—	—	—	—	—	—
		—	—	—	—	—	—	34.1/29.7	<b>45.7/39.8</b>	2400	—	—	—	—	—	—
		—	—	—	—	—	—	35.7/31.4	<b>47.9/42.1</b>	2600	—	—	—	—	—	—
		—	—	—	—	—	—	37.3/32.8	<b>50.0/44.0</b>	2800	—	—	—	—	—	—
		—	—	—	—	—	—	38.0/34.0	<b>51.0/45.6</b>	3000	—	—	—	—	—	—
C2.2	T	—	—	—	—	—	—	40.0	<b>53.6</b>	2600	—	—	—	—	—	—
		—	—	—	—	—	—	45.5	<b>61.0</b>	3000	—	—	—	—	—	—
C2.2	TA	—	—	—	—	—	—	49.2	<b>66.0</b>	2800	—	—	—	—	—	—
C3.4	NA	—	—	—	—	—	—	47.0	<b>63.0</b>	2500	—	—	—	—	—	—
C3.4	T	—	—	—	—	—	—	55.0	<b>73.7</b>	2500	—	—	—	—	—	—
		—	—	—	—	—	—	62.0	<b>83.0</b>	2500	—	—	—	—	—	—
3054C	NA	—	—	—	—	—	—	50.0	<b>67.0</b>	2200	—	—	—	—	—	—
		—	—	—	—	—	—	54.0	<b>72.0</b>	2200	—	—	—	—	—	—
		—	—	—	—	—	—	62.0	<b>83.0</b>	2400	—	—	—	—	—	—
		—	—	—	—	—	—	60.0	<b>80.0</b>	2200	—	—	—	—	—	—
		—	—	—	—	—	—	64.0	<b>86.0</b>	2400	—	—	—	—	—	—
3054C	T	—	—	—	—	—	—	60.0	<b>80.0</b>	2200	—	—	—	—	—	—
		—	—	—	—	—	—	64.5	<b>86.0</b>	2200	—	—	—	—	—	—
		—	—	—	—	—	—	72.5	<b>97.0</b>	2200	—	—	—	—	—	—
		—	—	—	—	—	—	72.5	<b>97.0</b>	2400	—	—	—	—	—	—
		—	—	—	—	—	—	74.5	<b>99.5</b>	2400	—	—	—	—	—	—
3054C	TA	—	—	—	—	—	—	78.5	<b>105.0</b>	2400	—	—	—	—	—	—
		—	—	—	—	—	—	83.5	<b>112.0</b>	2200	—	—	—	—	—	—
		—	—	—	—	—	—	87.0	<b>117.0</b>	2200	—	—	—	—	—	—
		—	—	—	—	—	—	95.0	<b>127.0</b>	2200	—	—	—	—	—	—
		—	—	—	—	—	—	97.0	<b>130.0</b>	2200	—	—	—	—	—	—
3054E	NA	—	—	—	—	—	—	64.0	<b>86.0</b>	2400	—	—	—	—	—	—
3054E	T	—	—	—	—	—	—	86.0	<b>115.0</b>	2500	—	—	—	—	—	—
3054E	TA	—	—	—	—	—	—	97.0	<b>130.0</b>	2200	—	—	—	—	—	—
C4.4	NA	—	—	—	—	—	—	54.5	<b>73.0</b>	2200	—	—	—	—	—	—
		—	—	—	—	—	—	56.0	<b>75.0</b>	2200	—	—	—	—	—	—
C4.4	T	—	—	—	—	—	—	55.5-74.5	<b>75.0-99.9</b>	2200-2400	—	—	—	—	—	—
C4.4	TA	—	—	—	—	—	—	74.5-83.0	<b>99.9-111.3</b>	2200-2400	—	—	—	—	—	—
C4.4	T ACERT	—	—	—	—	—	—	61.5-74.5	<b>82.5-99.0</b>	2200	—	—	—	—	—	—
C4.4	TA ACERT	—	—	—	—	—	—	74.5-106.0	<b>99.5-142.0</b>	2200	—	—	—	—	—	—

\*Specific application rating.

C2.2, C3.4, 3054C and E — Meets Tier 2, Stage II emissions requirements. Tier 2 refers to EPA (U.S.) requirements. Stage II refers to European requirements.

C2.2, C3.4 — Designed to meet Tier 3, Stage IIIA and Tier 4, Stage IIIB emissions requirements. Tier 3 and Tier 4 refer to EPA (U.S.) requirements. Stage IIIA and Stage IIIB refer to European requirements.

C4.4 and C4.4 ACERT — Meets Tier 3, Stage IIIA emissions requirements. Tier 3 refers to EPA (U.S.) requirements. Stage IIIA refers to European requirements.

## Cat Industrial Diesel Applications

Model	Type	"IND A"			"IND B"			"IND C"			"IND D"			"IND E"		
		bkW	bhp	rpm	bkW	bhp	rpm	bkW	bhp	rpm	bkW	bhp	rpm	bkW	bhp	rpm
C6.6 ACERT	TA	—	—	—	—	—	—	89.0	<b>119.4</b>	2200	—	—	—	—	—	—
		—	—	—	—	—	—	116.5	<b>156.2</b>	2200	—	—	—	—	—	—
		—	—	—	—	—	—	129.5	<b>173.7</b>	2200	—	—	—	—	—	—
		—	—	—	—	—	—	129.0	<b>173.0</b>	2500	—	—	—	—	—	—
		—	—	—	—	—	—	130.0	<b>174.3</b>	2500	—	—	—	—	—	—
		—	—	—	—	—	—	136.0	<b>182.4</b>	2200	—	—	—	—	—	—
		—	—	—	—	—	—	140.0	<b>187.7</b>	2200	—	—	—	—	—	—
		—	—	—	—	—	—	144.0	<b>193.1</b>	2200	—	—	—	—	—	—
		—	—	—	—	—	—	146.0	<b>195.8</b>	2200	—	—	—	—	—	—
		—	—	—	—	—	—	151.0	<b>202.5</b>	1800	—	—	—	—	—	—
		—	—	—	—	—	—	151.0	<b>202.5</b>	2200	—	—	—	—	—	—
		—	—	—	—	—	—	159.0	<b>213.2</b>	2200	—	—	—	—	—	—
		—	—	—	—	—	—	168.0	<b>225.3</b>	2200	—	—	—	—	—	—
		—	—	—	—	—	—	176.5	<b>236.7</b>	2200*	—	—	—	—	—	—
		—	—	—	—	—	—	186.0	<b>249.4</b>	2200	—	—	—	—	—	—
—	—	—	—	—	—	205.0	<b>274.9</b>	2200*	—	—	—	—	—	—		
C6.6 ACERT	TA IOPU	—	—	—	—	—	—	129.5	<b>173.7</b>	2200	—	—	—	—	—	
		—	—	—	—	—	—	130.0	<b>174.3</b>	2500	—	—	—	—	—	
		—	—	—	—	—	—	151.0	<b>202.5</b>	1800	—	—	—	—	—	
		—	—	—	—	—	—	151.0	<b>202.5</b>	2200	—	—	—	—	—	
		—	—	—	—	—	—	168.0	<b>225.3</b>	2200	—	—	—	—	—	
C7 ACERT	ATAAC	—	—	—	168	<b>225</b>	1800-2200	187.0	<b>250.0</b>	1800-2200	224	<b>300</b>	2100-2200	—	—	—
C9 ACERT	ATAAC	205	<b>275</b>	1800-2200	224	<b>300</b>	1800-2200	242.0	<b>325.0</b>	1800-2200	280	<b>375</b>	1800-2200	—	—	—
		—	—	—	—	—	—	261.0	<b>350.0</b>	1800-2200	—	—	—	—	—	—
C11 ACERT	ATAAC	242	<b>325</b>	1800-2100	261	<b>350</b>	1800-2100	287.0	<b>385.0</b>	1800-2100	313	<b>420</b>	1800-2100	336	<b>450</b>	1800-2100
C13 ACERT	ATAAC	287	<b>385</b>	1800-2100	310	<b>415</b>	1800-2100	328.0	<b>440.0</b>	1800-2100	354	<b>475</b>	1800-2100	388	<b>520</b>	1800-2100
3406C	T	201	<b>270</b>	1800	224	<b>300</b>	2000	242.0	<b>325.0</b>	2100	283	<b>380</b>	2100	291	<b>390</b>	2100
3406C	TA	199	<b>267</b>	1300	—	—	—	199.0	<b>267.0</b>	1300	—	—	—	—	—	—
		205	<b>275</b>	1800	242	<b>325</b>	2000	269.0	<b>360.0</b>	2100	313	<b>420</b>	2100	336	<b>450</b>	2100
		242	<b>325</b>	1800	242	<b>325</b>	2000	242.0	<b>325.0</b>	1800	—	—	—	—	—	—
		—	—	—	—	—	—	242.0	<b>325.0</b>	2100	—	—	—	—	—	—
		242	<b>325</b>	1800	276	<b>370</b>	2000	298.0	<b>400.0</b>	2100	358	<b>480</b>	2100	373	<b>500</b>	2100
		257	<b>345</b>	1800	254	<b>340</b>	2000	250.0	<b>335.0</b>	2100	—	—	—	—	—	—
		—	—	—	—	—	—	257.0	<b>345.0</b>	1800	—	—	—	—	—	—
		—	—	—	—	—	—	269.0	<b>360.0</b>	1800	283	<b>380</b>	2100	291	<b>390</b>	2100
		268	<b>360</b>	1800	268	<b>360</b>	2000	269.0	<b>360.0</b>	2100	298	<b>400</b>	2100	324	<b>435</b>	2100
		—	—	—	—	—	—	280.0	<b>375.0</b>	2000	—	—	—	—	—	—
		—	—	—	—	—	—	280.0	<b>375.0</b>	2100	—	—	—	—	—	—
		—	—	—	—	—	—	298.0	<b>400.0</b>	1800	—	—	—	—	—	—
		—	—	—	—	—	—	298.0	<b>400.0</b>	2000	—	—	—	—	—	—
		280	<b>375</b>	1800	291	<b>390</b>	2000	298.0	<b>400.0</b>	2100	324	<b>435</b>	2100	362	<b>485</b>	2100
		—	—	—	—	—	—	321.0	<b>430.0</b>	2100	—	—	—	—	—	—
		—	—	—	—	—	—	328.0	<b>440.0</b>	1800	—	—	—	—	—	—
		—	—	—	—	—	—	328.0	<b>440.0</b>	1900	366	<b>490</b>	2100	—	—	—
		—	—	—	—	—	—	328.0	<b>440.0</b>	2000	—	—	—	384	<b>515</b>	1900
		287	<b>385</b>	1800	328	<b>440</b>	2000	343.0	<b>460.0</b>	2100	373	<b>500</b>	2100	384	<b>515</b>	2100
313	<b>420</b>	1800	328	<b>440</b>	2000	343.0	<b>460.0</b>	2100	384	<b>515</b>	2100	392	<b>525</b>	2100		

\*Specific application rating.

C6.6 ACERT, C7 ACERT, C9, C9 ACERT, C10, C11, C12, C13 ACERT — Meets Tier 3, Stage IIIA emission requirements. Tier 3 refers to EPA (U.S.) requirements. Stage IIIA refers to European requirements.

Cat Industrial Diesel Applications

Model	Type	“IND A”			“IND B”			“IND C”			“IND D”			“IND E”		
		bkW	bhp	rpm	bkW	bhp	rpm	bkW	bhp	rpm	bkW	bhp	rpm	bkW	bhp	rpm
C15 ACERT	ATAAC	328	440	1800-2100	354.0	475	1800-2100	403	540	1800-2100	433	580	1800-2100	444	595	1800-2100
C18 ACERT	ATAAC	429	575	1800-2100	447.5	600	1800-2100	470	630	1800-2100	—	—	—	—	—	—
C18 ACERT	TTA (ATAAC)	—	—	—	—	—	—	522	700	1800-2100	571	765	1800-2100	597	800	1800-2100
C27 ACERT	TA (ATAAC)	597	800	1800-2100	653.0	875	1800-2100	708	950	1800-2100	783	1050	1800-2100	858	1150	1800-2100
C32 ACERT	TA (ATAAC)	—	—	—	708.0	950	1800-2100	839	1125	1800-2100	895	1200	1800-2100	1007	1350	1800-2100
3508	TA	507	680	1200	—	—	—	612	820	1300	—	—	—	—	—	—
		578	775	1800	—	—	—	634	850	1800	—	—	—	—	—	—
		638	855	1800	—	—	—	746	1000	1800	—	—	—	—	—	—
3508B	TA	746	1000	1800	—	—	—	820	1100	1800	—	—	—	—	—	—
3512	TA	761	1020	1200	—	—	—	858	1150	1300	—	—	—	—	—	—
		877	1175	1800	—	—	—	1007	1350	1800	—	—	—	—	—	—
		955	1280	1800	—	—	—	1119	1500	1800	—	—	—	—	—	—
3512B	TA	1119	1500	1800	—	—	—	1231	1650	1800	—	—	—	—	—	—
3516	TA	1011	1355	1200	—	—	—	1242	1665	1300	—	—	—	—	—	—
		1156	1550	1800	—	—	—	1268	1700	1800	—	—	—	—	—	—
		1275	1710	1800	—	—	—	1492	2000	1800	—	—	—	—	—	—
3516B	TA	1492	2000	1800	—	—	—	1566	2100	1800	—	—	—	—	—	—
3606	TA	1490	1998	750	—	—	—	—	—	—	—	—	—	—	—	—
		1560	2092	800	—	—	—	—	—	—	—	—	—	—	—	—
		1730	2319	900	—	—	—	—	—	—	—	—	—	—	—	—
		1850	2481	1000	—	—	—	—	—	—	—	—	—	—	—	—
3608	TA	1980	2655	750	—	—	—	—	—	—	—	—	—	—	—	—
		2080	2787	800	—	—	—	—	—	—	—	—	—	—	—	—
		2300	3080	900	—	—	—	—	—	—	—	—	—	—	—	—
		2460	3300	1000	—	—	—	—	—	—	—	—	—	—	—	—
3612	TA	2980	3996	750	—	—	—	—	—	—	—	—	—	—	—	—
		3120	4184	800	—	—	—	—	—	—	—	—	—	—	—	—
		3460	4640	900	—	—	—	—	—	—	—	—	—	—	—	—
		3700	4962	1000	—	—	—	—	—	—	—	—	—	—	—	—
3616	TA	3960	5310	750	—	—	—	—	—	—	—	—	—	—	—	—
		4160	5579	800	—	—	—	—	—	—	—	—	—	—	—	—
		4600	6169	900	—	—	—	—	—	—	—	—	—	—	—	—
		4920	6598	1000	—	—	—	—	—	—	—	—	—	—	—	—

C15 ACERT — Meets Tier 3, Stage IIIA emissions requirements. Tier 3 refers to EPA (U.S.) requirements. Stage IIIA refers to European requirements.  
 C18 ACERT — A, B, and C ratings meet Tier 3, Stage IIIA emissions requirements. Tier 3 refers to EPA (U.S.) requirements. Stage IIIA refers to European requirements.  
 D and E ratings meet Tier 2 emissions requirements above 559 bkW (751 bhp). Tier 2 refers to EPA (U.S.) requirements.  
 C27 and C32 — Meets Tier 2 emissions requirements. Tier 2 refers to EPA (U.S.) requirements.

## Cat Industrial Diesel Applications

### Cat Diesel Engines for Fire Pump Packages

Model	No. of Cylinders	1460 rpm		1750 rpm		1900 rpm		2100 rpm		2200 rpm		2300 rpm	
		bkW	bhp	bkW	bhp	bkW	bhp	bkW	bhp	bkW	bhp	bkW	bhp
<b>3406C* T</b>	I6	183	<b>247</b>	218	<b>292</b>	233	<b>312</b>	246	<b>330</b>	—	—	261	<b>350</b>
<b>3406C* T</b>	I6	242	<b>325</b>	276	<b>370</b>	280	<b>375</b>	280	<b>375</b>	—	—	—	—
<b>3406C* TA</b>	I6	224	<b>300</b>	313	<b>420</b>	317	<b>425</b>	321	<b>430</b>	—	—	339	<b>455</b>
<b>3406C* TA</b>	I6	—	—	343	<b>460</b>	343	<b>460</b>	359	<b>482</b>	—	—	—	—
<b>3412C** T</b>	V12	466	<b>625</b>	401	<b>538</b>	507	<b>680</b>	427	<b>573</b>	—	—	466	<b>625</b>
<b>3412C** T</b>	V12	—	—	492	<b>660</b>	—	—	522	<b>700</b>	—	—	—	—
<b>3412C** TA</b>	V12	—	—	476	<b>638</b>	551	<b>739</b>	551	<b>739</b>	—	—	649	<b>870</b>
<b>3412C** TA</b>	V12	—	—	597	<b>800</b>	642	<b>860</b>	649	<b>870</b>	—	—	—	—
<b>3508** TA</b>	V8	709	<b>950</b>	794	<b>1065</b>	—	—	—	—	—	—	—	—
<b>3512** TA</b>	V12	1067	<b>1430</b>	1193	<b>1600</b>	—	—	—	—	—	—	—	—
<b>3516** TA</b>	V16	1417	<b>1900</b>	1480	<b>1985</b>	—	—	—	—	—	—	—	—

\*New Source Performance Standard (NSPS) compliant.

\*\*For export out of the U.S. only.

T — Turbocharged

TA — Turbocharged-Aftercooled

#### Rating Definition:

**Standby:** Fire pump engine ratings represent the output which may be utilized to drive stationary fire pumps where the pumping equipment has been sized according to ULI and FM procedures.

Cat Oil and Gas Engines

Gas Industrial Ratings

Model	900 rpm		1000 rpm		1200 rpm		1400 rpm		1500 rpm		1600 rpm		1800 rpm	
	bkW	bhp	bkW	bhp	bkW	bhp	bkW	bhp	bkW	bhp	bkW	bhp	bkW	bhp
G3304	NA	—	—	—	—	—	56	75	—	—	64	85	71	95
G3306	NA	—	—	—	—	—	—	—	—	—	—	—	108	145
G3306	TA	—	—	—	—	—	—	—	—	—	—	—	157	211
G3306	TA <sup>2</sup>	—	—	—	—	—	—	—	—	—	—	—	151	203
G3306	TA <sup>1</sup>	—	—	—	—	—	—	—	—	—	—	—	164	220
G3406	NA	—	—	—	—	—	131	175	—	—	—	—	160	215
G3406	TA <sup>2,4</sup>	—	—	—	—	—	—	—	—	—	—	—	206	276
G3406	TA <sup>4</sup>	—	—	—	—	—	—	—	—	—	—	—	218	292
G3406	TA <sup>2</sup>	—	—	—	—	—	187	250	—	—	—	—	242	325
G3406	TA <sup>1</sup>	—	—	—	—	—	—	—	—	—	—	—	257	345
G3406	TA <sup>1</sup>	—	—	—	—	—	209	280	—	—	—	—	272	365
G3408	NA	—	—	—	—	—	157	210	—	—	—	—	190	255
G3408	TA <sup>2</sup>	—	—	—	—	—	223	300	—	—	—	—	—	—
G3408	TA <sup>2</sup>	—	—	—	—	—	223	300	—	—	—	—	298	400
G3408	TA <sup>1</sup>	—	—	—	—	—	246	330	—	—	—	—	—	—
G3408	TA <sup>2,4</sup>	—	—	—	—	—	—	—	248	332	—	—	—	—
G3408	TA <sup>1,4</sup>	—	—	—	—	—	261	350	—	—	—	—	302	405
G3408	TA <sup>2,3</sup>	—	—	—	—	—	—	—	—	—	—	—	317	425
G3408	TA <sup>1</sup>	—	—	—	—	—	261	350	—	—	—	—	336	450
G3412	NA	—	—	—	—	—	235	315	—	—	—	—	272	365
G3412	TA <sup>2,4</sup>	—	—	—	—	—	302	405	—	—	—	—	—	—
G3412	TA <sup>2,4</sup>	—	—	—	—	—	—	—	373	500	—	—	—	—
G3412	TA <sup>2</sup>	—	—	—	—	—	335	450	—	—	—	—	—	—
G3412	TA <sup>2</sup>	—	—	—	—	—	347	465	—	—	—	—	448	600
G3412	TA <sup>1,3</sup>	—	—	—	—	—	369	495	—	—	—	—	—	—
G3412	TA <sup>1</sup>	—	—	—	—	—	392	525	—	—	—	—	—	—
G3412	TA <sup>1,4</sup>	—	—	—	—	—	—	—	—	—	—	—	453	607
G3412	TA <sup>2,3</sup>	—	—	—	—	—	—	—	—	—	—	—	475	637
G3412	TA <sup>1,3,4</sup>	—	—	—	—	—	—	—	—	—	—	—	504	675

<sup>1</sup> 32° C (90° F) water to aftercooler.

<sup>2</sup> 54° C (130° F) water to aftercooler.

<sup>3</sup> Low Emissions.

<sup>4</sup> Catalyst Rating.

Ratings listed are for 25° C (77° F) ambient temperature, 152 m (500 ft) altitude, and pipeline quality gas.

NA — Naturally Aspirated

TA — Turbocharged-Aftercooled

bhp — Brake horsepower

bkW — Metric equivalent of brake horsepower

**Rating Definition:**

**Continuous:** Output available without varying load for an unlimited time. Continuous power in accordance with ISO 8528, ISO 3046/1, AS2789, DIN6271, and BS5514.

## Cat Oil and Gas Engines

## Gas Industrial Ratings

Model	900 rpm		1000 rpm		1200 rpm		1400 rpm		1500 rpm		1600 rpm		1800 rpm	
	bkW	bhp	bkW	bhp	bkW	bhp	bkW	bhp	bkW	bhp	bkW	bhp	bkW	bhp
G3508	NA	—	—	—	231	310	—	—	—	—	—	—	—	—
G3508	TA <sup>3,4</sup>	—	—	—	384	515	472	630	—	—	—	—	—	—
G3805	TA <sup>3</sup>	—	—	—	391	524	—	—	—	—	—	—	—	—
G3508	TA <sup>2,4</sup>	—	—	—	395	530	485	650	—	—	—	—	—	—
G3508	TA <sup>2</sup>	—	—	—	399	535	—	—	—	—	—	—	—	—
G3508	TA <sup>1</sup>	—	—	—	406	545	—	—	—	—	—	—	—	—
G3508	TA <sup>1,4</sup>	—	—	—	407	545	500	670	—	—	—	—	—	—
G3512	NA	—	—	—	391	525	—	—	—	—	—	—	—	—
G3512	TA <sup>3</sup>	—	—	—	589	790	—	—	—	—	—	—	—	—
G3512	TA <sup>2</sup>	—	—	—	595	800	—	—	—	—	—	—	—	—
G3512	TA <sup>3,4</sup>	—	—	—	604	810	705	945	—	—	—	—	—	—
G3512	TA <sup>1</sup>	—	—	—	607	815	—	—	—	—	—	—	—	—
G3512	TA <sup>2,4</sup>	—	—	—	623	835	727	975	—	—	—	—	—	—
G3512	TA <sup>3,4</sup>	—	—	—	642	860	749	1005	—	—	—	—	—	—
G3516	NA	—	—	—	492	660	—	—	—	—	—	—	—	—
G3516	TA <sup>3</sup>	—	—	—	783	1050	—	—	—	—	—	—	—	—
G3516	TA <sup>2</sup>	—	—	—	794	1065	—	—	—	—	—	—	—	—
G3516	TA <sup>3,4</sup>	—	—	—	809	1085	943	1265	—	—	—	—	—	—
G3516	TA <sup>2,4</sup>	—	—	—	831	1115	969	1300	—	—	—	—	—	—
G3516	TA <sup>3,4</sup>	—	—	—	858	1150	1000	1340	—	—	—	—	—	—
G3520B	TA	—	—	—	965	1294	1286	1725	—	—	—	—	—	—
G3606	TA <sup>2,3</sup>	1193	1600	1324	1775	—	—	—	—	—	—	—	—	—
G3606	TA <sup>1,3</sup>	1271	1705	1413	1895	—	—	—	—	—	—	—	—	—
G3608	TA <sup>2,3</sup>	1591	2133	1767	2370	—	—	—	—	—	—	—	—	—
G3608	TA <sup>1,3</sup>	1693	2270	1879	2520	—	—	—	—	—	—	—	—	—
G3612	TA <sup>2,3</sup>	2383	3195	2647	3550	—	—	—	—	—	—	—	—	—
G3612	TA <sup>1,3</sup>	2539	3405	2822	3785	—	—	—	—	—	—	—	—	—
G3616	TA <sup>2,3</sup>	3178	4261	3531	4735	—	—	—	—	—	—	—	—	—
G3616	TA <sup>1,3</sup>	3389	4545	3762	5045	—	—	—	—	—	—	—	—	—
G16CM34	TA	—	—	—	—	—	—	—	—	—	—	—	—	—

<sup>1</sup> 32° C (90° F) water to aftercooler.<sup>2</sup> 54° C (130° F) water to aftercooler.<sup>3</sup> Low Emissions.<sup>4</sup> Catalyst Rating.

Ratings listed are for 25° C (77° F) ambient temperature, 152 m (500 ft) altitude, and pipeline quality gas.

NA — Naturally Aspirated

TA — Turbocharged-Aftercooled

bhp — Brake horsepower

bkW — Metric equivalent of brake horsepower

**Rating Definition:****Continuous:** Output available without varying load for an unlimited time. Continuous power in accordance with ISO 8528, ISO 3046/1, AS2789, DIN6271, and BS5514.

- Cat Oil and Gas Engines
- Offshore Power Module Ratings
  - Land Rig Power Module Ratings

## Engines

### Cat Oil and Gas Engines

#### Offshore Power Module Ratings

Model	L with Base		W of Base		H with Base		Approximate Weight with Base	
	m	ft	mm	in	mm	in	kg	lb
3512B	5.44	17'10"	1790	71	2225	90	13 970	30,800
3512B HD	5.44	17'10"	1790	71	2225	90	14 515	32,000
3516B	6.10	20'0"	1790	71	2225	90	16 740	36,900
3516B HD	6.40	21'0"	1790	71	2225	90	17 236	38,000
3606	7.39	24'3"	1905	75	3250	128	37 194	82,000
3608	9.91	32'6"	1905	75	3250	128	44 452	98,000
3612	9.45	31'0"	2085	82	3300	130	55 340	122,000
3616	10.06	33'0"	2085	82	3300	130	65 317	144,000
12CM32	11.05	36'2"	2800	110	5357	211	121 000	266,200
16CM32	12.40	40'8"	2800	110	5357	211	148 000	325,600

#### Land Rig Power Module Ratings

Model	L Bases Available*	W of Base		Radiator Height with Base		Approximate Weight with Base	
	7.85 m (25'9")	mm	in	mm	in	kg	lb
3508	X	2390	94	2896	114	13 155	29,000
3508B	X	2390	94	2896	114	13 155	29,000
3512	X	2390	94	2896	114	15 875	35,000
3512B	X	2390	94	2896	114	15 875	35,000
3512B HD	X	2390	94	2896	114	16 798	37,000
3516	X	2390	94	2896	114	18 600	41,000
3516B	X	2390	94	2896	114	18 600	41,000

\*9.37 m (30'9") and 12.4 m (40'9") bases also available.



## Cat Oil and Gas Engines

## Electric Drive Engine Ratings for SCR and DC Powered Rigs

Model	No. Cyl.	60 Hz								50 Hz					
		720 rpm		900 rpm		1200 rpm		1800 rpm		750 rpm		1000 rpm		1500 rpm	
		bkW	bhp	bkW	bhp	bkW	bhp	bkW	bhp	bkW	bhp	bkW	bhp	bkW	bhp
<b>C16</b>	I-6	—	—	—	—	—	—	410	<b>550<sup>1</sup></b>	—	—	—	—	—	—
<b>3412E</b>	V-12	—	—	—	—	—	—	577	<b>760<sup>1</sup></b>	—	—	—	—	—	—
<b>3412E</b>	V-12	—	—	—	—	354	<b>475<sup>1</sup></b>	—	—	—	—	—	—	—	—
<b>3508</b>	V-8	—	—	—	—	641	<b>860<sup>1</sup></b>	—	—	—	—	—	—	—	—
<b>3508B</b>	V-8	—	—	—	—	682	<b>915<sup>1</sup></b>	—	—	—	—	—	—	880	<b>1180</b>
<b>3512</b>	V-12	—	—	—	—	709	<b>950<sup>1</sup></b>	—	—	—	—	—	—	1090	<b>1462</b>
<b>3512C</b>	V-12	—	—	—	—	1678	<b>2250</b>	—	—	—	—	—	—	—	—
<b>3512C HD</b>	V-12	—	—	—	—	1101	<b>1475</b>	—	—	—	—	—	—	1310	<b>1757</b>
<b>3516C HD</b>	V-16	—	—	—	—	1345	<b>1804<sup>1</sup></b>	—	—	—	—	—	—	—	—
<b>3516C</b>	V-16	—	—	—	—	1384	<b>1855<sup>3</sup></b>	—	—	—	—	—	—	—	—
<b>3516C HD</b>	V-16	—	—	—	—	1604	<b>2150<sup>3</sup></b>	—	—	—	—	—	—	—	—
<b>3606C</b>	I-6	1565	<b>2100<sup>2</sup></b>	1880	<b>2520<sup>2</sup></b>	—	—	—	—	1645	<b>2210<sup>2</sup></b>	2010	<b>2700<sup>2</sup></b>	—	—
<b>3608</b>	I-8	2085	<b>2800<sup>2</sup></b>	2533	<b>3395<sup>2</sup></b>	—	—	—	—	2155	<b>2890<sup>2</sup></b>	2700	<b>3630<sup>2</sup></b>	—	—
<b>3612</b>	V-12	3130	<b>4200<sup>2</sup></b>	3802	<b>5096<sup>2</sup></b>	—	—	—	—	3285	<b>4410<sup>2</sup></b>	4025	<b>5400<sup>2</sup></b>	—	—
<b>3616</b>	V-16	4180	<b>5600<sup>2</sup></b>	4604	<b>6172<sup>2</sup></b>	—	—	—	—	4315	<b>5790<sup>2</sup></b>	5415	<b>7260<sup>2</sup></b>	—	—
<b>12CM32</b>	V-12	5760	<b>7724</b>	—	—	—	—	—	—	6000	<b>8160</b>	—	—	—	—
<b>16CM32</b>	V-16	7680	<b>10,300</b>	—	—	—	—	—	—	8000	<b>10,880</b>	—	—	—	—

<sup>1</sup> EPA certified.<sup>2</sup> IMO certified.<sup>3</sup> EPA and IMO certified.

bhp — Brake horsepower

bkW — Metric equivalent of brake horsepower

Requires Separate Circuit Aftercooling (SCAC), without fan power, when emissions compliant.

**Cat Oil and Gas Engines**

**Mechanical Drill Rig Ratings**

Model	Pumping and Drilling Ratings (B Level)				
	No. Cyl.	1400 rpm		1200 rpm	
		bkW	bhp	bkW	bhp
<b>3412E***</b>	V-12	466	<b>625</b>	—	—
<b>3508**</b>	V-8	—	—	567	<b>760</b>
<b>3508B*</b>	V-8	—	—	567	<b>760</b>
<b>3508B*</b>	V-8	—	—	671	<b>900</b>
<b>3512B</b>	V-12	—	—	783	<b>1050</b>
<b>3512B</b>	V-12	—	—	1044	<b>1400</b>
<b>3516**</b>	V-16	—	—	1044	<b>1400</b>
<b>3516**</b>	V-16	—	—	1230	<b>1649</b>

\*2002 U.S. EPA and IMO certified, Separate Circuit Aftercooling (SCAC), without fan.

\*\*Not U.S. EPA and IMO certified, Jacket Water Aftercooling (JWAC), without fan.

\*\*\*2002 U.S. EPA and IMO certified, Air to Air Aftercooled (ATAAC), without fan.

bhp — Brake horsepower

bkW — Metric equivalent of brake horsepower

**Fracturing/Acidizing/Cementing Ratings**

Dry Manifolds (E Level)				
Model	bkW	bhp	rpm	2002 EPA, Carb & EU 97/68/EC
<b>C10</b>	317	<b>425</b>	2100	X
<b>C12</b>	373	<b>500</b>	2100	X
<b>C15</b>	428	<b>575</b>	2100	X
<b>C16</b>	492	<b>660</b>	2100	X
<b>C32</b>	1119	<b>1500</b>	2100	X
<b>3512B*</b>	1492	<b>2000</b>	1900	X
<b>3512B</b>	1604	<b>2150</b>	1900	X
<b>3512B</b>	1679	<b>2250</b>	1900	X

Water Cooled Manifolds (E Level)				
Model	bkW	bhp	rpm	2002 EPA and IMO
<b>C10*</b>	272	<b>365</b>	2100	X
<b>C15*</b>	373	<b>500</b>	2100	X
<b>3126**</b>	172	<b>230</b>	2600	X
<b>3406*</b>	365	<b>490</b>	2100	X
<b>3412E*</b>	642	<b>860</b>	2100	X
<b>3412E</b>	780	<b>1050</b>	2100	X

\*D Rating Level — cementing.

\*\*C Rating Level.

STA — Series Turbocharged-Aftercooled

bhp — Brake horsepower

bkW — Metric equivalent of brake horsepower

E Rating Level — fracturing.

**Rating Definitions:**

The horsepower and speed capability of the engine which can be used to power high pressure well servicing equipment.

**NOTE:** For a transmission match, consult your transmission supplier.

# Engines

## Cat Railway Power

- Locomotive Traction Engine Ratings
- Auxiliary Electric (Head End) Power Engine Ratings

### Cat Railway Power

#### Locomotive Traction Engine Ratings

Model	Rated Speed	Low Rating		High Rating	
	rpm	kW	hp	kW	hp
<b>C9 ACERT</b>	1800-2200	205	<b>275</b>	280	<b>375</b>
<b>C11 ACERT</b>	1800-2100	242	<b>325</b>	336	<b>450</b>
<b>C13 ACERT</b>	1800-2100	287	<b>385</b>	388	<b>520</b>
<b>3406C</b>	1300-2100	199	<b>267</b>	392	<b>525</b>
<b>C15 ACERT</b>	1800-2100	328	<b>440</b>	444	<b>595</b>
<b>C18 ACERT</b>	1800-2100	429	<b>575</b>	597	<b>800</b>
<b>C18 ACERT-Horizontal*</b>	1800	—	—	522	<b>700</b>
<b>C27 ACERT</b>	1800-2100	597	<b>800</b>	858	<b>1150</b>
<b>C32 ACERT</b>	1800-2100	708	<b>950</b>	1007	<b>1350</b>
<b>C175-16 ACERT</b>	1800	2500	<b>3351</b>	2700	<b>3620</b>
<b>3508</b>	1300-1800	503	<b>675</b>	970	<b>1300</b>
<b>3512</b>	1300-1800	746	<b>1000</b>	1700	<b>2280</b>
<b>3516</b>	1300-1800	1200	<b>1600</b>	2300	<b>3085</b>
<b>3606</b>	750-1000	1640	<b>2200</b>	2030	<b>2720</b>
<b>3608</b>	750-1000	2180	<b>2925</b>	2710	<b>3635</b>
<b>3612</b>	750-1000	3280	<b>4400</b>	4060	<b>5445</b>
<b>3616</b>	750-1000	4360	<b>5850</b>	5420	<b>7270</b>

\*Preliminary rating.

#### Auxiliary Electric (Head End) Power Engine Ratings

Model	Rating (Hz)	Power (ekW)	Emissions Tier
<b>C15 ACERT</b>	50	292	STAGE II
<b>C15 ACERT</b>	50	328	STAGE II
<b>C15 ACERT</b>	50	364	STAGE II
<b>C15 ACERT</b>	50	400	STAGE II
<b>C15 ACERT</b>	60	320	TIER 3
<b>C15 ACERT</b>	60	365	TIER 3
<b>C15 ACERT</b>	60	410	TIER 3
<b>C15 ACERT</b>	60	455	TIER 3
<b>C18 ACERT</b>	50	400	STAGE II
<b>C18 ACERT</b>	50	436	STAGE II
<b>C18 ACERT</b>	50	508	STAGE II
<b>C18 ACERT</b>	50	573	STAGE II
<b>C18 ACERT</b>	60	500	TIER 2
<b>C18 ACERT</b>	60	545	TIER 2
<b>C27 ACERT</b>	60	590	TIER 2
<b>C27 ACERT</b>	60	635	TIER 2
<b>C27 ACERT</b>	60	680	TIER 2
<b>C27 ACERT</b>	60	725	TIER 2

All 60 Hz ratings are EPA Tier 2 or Tier 3 and CARB emission certified (non-road mobile regulations).

All 50 Hz ratings are EU emission certified (non-road mobile regulations).

Maintenance of Way Engine Ratings

Model	Aspiration	Rated Speed	Low Rating		High Rating	
		rpm	kW	hp	kW	hp
C0.5	NA	2800-3600	8.2	11.0	10.2	13.7
C0.7	NA	2800-3600	12.2	16.3	15.3	20.5
C1.1	NA	2200-3400	13.7	18.3	21.0	28.2
C1.5	NA	2200-3000	20.7	27.8	25.1	33.7
C1.5	T	2200-3000	23.1	30.0	30.0	40.2
C1.6	NA	2800-3000	24.6	33.0	26.5	35.5
C1.7	NA	2400-2600	24.7	33.2	26.0	34.8
C2.2	NA	2200-3000	27.5	36.9	38.0	51.0
C2.2	T	2600-3000	40.0	53.6	45.5	61.0
C2.2	TA	2800	—	—	49.2	66.0
C3.4	NA	2500	—	—	47.0	63.0
C3.4	T	2500	55.0	73.7	62.0	83.0
3054C	NA	2200-2400	50.0	67.0	64.0	86.0
3054C	T	2200-2400	60.0	80.0	74.5	99.5
3054C	TA	2200-2400	78.5	105.0	97.0	130.0
3054E	NA	2400	—	—	64.0	86.0
3054E	T	2500	—	—	86.0	115.0
3054E	TA	2200	—	—	97.0	130.0
C4.4	NA	2200	54.5	73.0	56.0	75.0
C4.4	T	2200-2400	55.5	75.0	74.5	99.9
C4.4	TA	2200-2400	74.5	99.9	83.0	111.3
C4.4 ACERT	T	2200	61.5	82.5	74.5	99.0
C4.4 ACERT	TA	2200	74.5	99.5	106.0	142.0
C6.6 ACERT	TA	1800-2500	89.0	119.4	205.0	274.9
C7 ACERT	TA	1800-2200	168.0	225.0	224.0	300.0
C9 ACERT	TA	1800-2200	205.0	275.0	280.0	375.0
C11 ACERT	TA	1800-2100	242.0	325.0	336.0	450.0
C13 ACERT	TA	1800-2100	287.0	385.0	388.0	520.0
3406C	T	1800-2100	201.0	270.0	291.0	390.0
3406C	TA	1300-2100	199.0	267.0	392.0	525.0
C15 ACERT	TA	1800-2100	328.0	440.0	444.0	595.0
C18 ACERT	TA	1800-2100	429.0	575.0	597.0	800.0
C27 ACERT	TA	1800-2100	597.0	800.0	858.0	1150.0
C32 ACERT	TA	1800-2100	708.0	950.0	1007.0	1350.0
3508	TA	1200-1800	507.0	680.0	746.0	1000.0
3512	TA	1200-1800	761.0	1020.0	1119.0	1500.0
3516	TA	1200-1800	1011.0	1355.0	1492.0	2000.0

Ratings meet appropriate non-road mobile emissions regulations.  
 Specific EPA or EU emissions information is available through your Cat dealer.

NA — Naturally Aspirated  
 T — Turbocharged  
 TA — Turbocharged/Aftercooled



# FORMER MODELS



## TRACK-TYPE TRACTORS

Model	Product Ident. No. Prefix	Years Built	Horsepower FW/ Drawbar	Approx. Machine Weight kg (lb)	Gauge m (ft) and Width m (ft)	Length m (ft) and Height m (ft)	Transmission	Rated Drawbar Pull — kg (lb) and Forward Speed — km/h (mph)					
								1st	2nd	3rd	4th	5th	6th
D2	4U	47-58	43/38	3258 (7175)	1.02 (3'4") 1.42 (4'8")	2.74 (9'0") 1.57 (5'2")	DD	3609 (7950)	2588 (5700)	2061 (4540)	1634 (3600)	1067 (2350)	
D2	4U	47-58	42/35	3258 (7175)	1.02 (3'4") 1.57 (5'2")	2.74 (9'0") 1.57 (5'2")	DD	3609 (7950)	2588 (5700)	2061 (4540)	1634 (3600)	1067 (2350)	
D2	5U	57-58	38/32	3119 (5870)	1.27 (4'2") 1.42 (4'8")	2.74 (9'0") 1.57 (5'2")	DD	3033 (6680)	2483 (5420)	2007 (4420)	1703 (3570)	1035 (2280)	
D2	5U	57-58	43/38	3373 (7430)	1.27 (4'2") 1.67 (5'6")	2.74 (9'0") 1.57 (5'2")	DD	3609 (7950)	2588 (5700)	2061 (4540)	1634 (3600)	1067 (2250)	
D3	79U	72-79	62/—	4812 (10,610)	1.42 (4'8") 1.78 (5'10")	2.77 (9'1") 1.70 (5'7")	PS						
D3 LGP	6N	72-79	62/—	5410 (11,925)	1.65 (5'5") 2.29 (7'6")	2.97 (9'10") 1.70 (5'7")	PS						
D3B	23Y	79-87	65	6719 (14,812)	1.42 (4'8") 1.78 (5'10")	2.77 (9'1") 2.67 (8'9")	PS						
D3B	27Y	79-87	65	6877 (15,160)	1.42 (4'8") 1.78 (5'10")	2.77 (9'1") 2.67 (8'9")	PS						
D3B LGP	24Y	79-87	65	7479 (16,488)	1.65 (5'5") 2.29 (7'6")	2.99 (9'10") 2.67 (8'9")	PS						
D3B LGP	28Y	79-87	65	7637 (16,836)	1.65 (5'5") 2.29 (7'6")	2.99 (9'10") 2.67 (8'9")	PS						
D3B	3YC	85-87	65	6719 (14,812)	1.42 (4'8") 1.78 (5'10")	2.77 (9'1") 2.67 (8'9")	DD						
D3B LGP	5MC	85-87	65	7479 (16,488)	1.65 (5'5") 2.29 (7'6")	2.99 (9'10") 2.67 (8'9")	DD						

NOTE: Power Shift models show speeds only, not drawbar pull.

NOTE: Track-Type Tractor weights do not include blades until 1967.

Track-Type Tractors (cont'd)

Model	Product Ident. No. Prefix	Years Built	Horse-power FW/ Drawbar	Approx. Machine Weight kg (lb)	Gauge m (ft) and Width m (ft)	Length m (ft) and Height m (ft)	Transmission	Rated Drawbar Pull — kg (lb) and Forward Speed — km/h (mph)						
								1st	2nd	3rd	4th	5th	6th	
D3C	5KG	87-90	67	7084 <b>(15,618)</b>	1.42 <b>(4'8")</b> 1.79 <b>(5'10.6")</b>	2.8 <b>(9'4")</b> 2.66 <b>(8'8.9")</b>	PS	3.1 <b>(1.9)</b>	5.9 <b>(3.7)</b>	10.8 <b>(6.7)</b>				
D3C Series II		90-93	70	7001 <b>(15,435)</b>	1.42 <b>(4'8")</b> 1.79 <b>(5'11")</b>		PS	3.1 <b>(1.9)</b>	5.9 <b>(3.7)</b>	10.8 <b>(6.7)</b>				
D3C Series III		93-01	70	7110 <b>(15,650)</b>	1.45 <b>(4'9")</b> 1.85 <b>(6'1")</b>	3.98 <b>(13'1")</b> 2.73 <b>(8'11")</b>	HYS		0-9.0 <b>(0-5.6)</b>					
D3C XL Series II		91-93	70	7242 <b>(15,965)</b>	1.42 <b>(4'8")</b> 1.83 <b>(6'0")</b>		PS	3.1 <b>(1.9)</b>	5.9 <b>(3.7)</b>	10.8 <b>(6.7)</b>				
D3C XL Series III		93-01	70	7304 <b>(16,100)</b>	1.45 <b>(4'9")</b> 1.85 <b>(6'1")</b>	3.98 <b>(13'1")</b> 2.73 <b>(8'11")</b>	HYS		0-9.0 <b>(0-5.6)</b>					
D3G XL	CFC	01-03	70	7314 <b>(16,125)</b>	1.45 <b>(4'9")</b> 1.85 <b>(6'1")</b>	4.02 <b>(13'2")</b> 2.72 <b>(8'11")</b>	HYS		0-9.0 <b>(0-5.6)</b>					
D3G XL Tier 2	JMH	03-07	70	7345 <b>(16,193)</b>	1.45 <b>(4'9")</b> 1.85 <b>(6'1")</b>	4.02 <b>(13'2")</b> 2.72 <b>(8'11")</b>	HYS		0-9.0 <b>(0-5.6)</b>					
D3C LGP	1PJ	87-90	67	7788 <b>(17,170)</b>	1.65 <b>(5'4")</b> 2.29 <b>(7'6")</b>	3.0 <b>(9'10.1")</b> 2.66 <b>(8'8.9")</b>	PS	3.1 <b>(1.9)</b>	5.9 <b>(3.7)</b>	10.8 <b>(6.7)</b>				
D3C LGP Series II		90-93	70	7788 <b>(17,170)</b>	1.65 <b>(5'5")</b> 2.29 <b>(7'6")</b>		PS	3.1 <b>(1.9)</b>	5.9 <b>(3.7)</b>	10.8 <b>(6.7)</b>				
D3C LGP Series III		93-01	70	7710 <b>(17,000)</b>	1.68 <b>(5'6")</b> 2.31 <b>(7'7")</b>	3.95 <b>(13'0")</b> 2.73 <b>(8'11")</b>	HYS		0-9.0 <b>(0-5.6)</b>					
D3G LGP	CFF	01-03	70	7723 <b>(17,026)</b>	1.68 <b>(5'6")</b> 2.31 <b>(7'7")</b>	4.02 <b>(13'2")</b> 2.72 <b>(8'11")</b>	HYS		0-9.0 <b>(0-5.6)</b>					
D3G LGP Tier 2	BYR	03-07	70	7768 <b>(17,126)</b>	1.68 <b>(5'6")</b> 2.31 <b>(7'7")</b>	4.02 <b>(13'2")</b> 2.72 <b>(8'11")</b>	HYS		0-9.0 <b>(0-5.6)</b>					

NOTE: Power Shift models show speeds only, not drawbar pull.  
NOTE: Track-Type Tractor weights do not include blades until 1967.

## Track-Type Tractors (cont'd)

Model	Product Ident. No. Prefix	Years Built	Horse-power FW/ Drawbar	Approx. Machine Weight kg (lb)	Gauge m (ft) and Width m (ft)	Length m (ft) and Height m (ft)	Transmission	Rated Drawbar Pull — kg (lb) and Forward Speed — km/h (mph)						
								1st	2nd	3rd	4th	5th	6th	
D4	6U	47-59	48/43	4629 (10,195)	1.12 (3'8") 1.58 (5'2")	3.07 (11'0") 1.54 (5'1")	DD	4531 (9980) 2.7 (1.7)	3496 (7700) 4.2 (2.4)	2656 (5850) 4.8 (3.0)	2089 (4600) 6.0 (3.7)	1339 (2950) 8.7 (5.4)		
D4	6U	47-59	60/48	4847 (10,675)	1.12 (3'8") 1.58 (5'2")	3.16 (10'5") 1.54 (5'1")	DD	4858 (10,700) 3.1 (1.9)	3496 (7700) 4.3 (2.7)	2724 (6000) 5.5 (3.4)	2093 (4610) 6.8 (4.2)	1326 (2920) 9.8 (6.1)		
D4	6U	47-59	63/50	4844 (10,675)	1.12 (3'8") 1.58 (5'2")	3.18 (10'5") 1.76 (5'10")	DD	4858 (10,700) 3.1 (1.9)	3528 (7770) 4.3 (2.7)	2724 (6000) 5.5 (3.4)	2093 (4610) 6.8 (4.2)	1326 (2920) 9.8 (6.1)		
D4	7U	47-59	63/50	5067 (10,970)	1.52 (5'0") 1.98 (6'6")	3.16 (10'5") 1.76 (5'10")	DD	4858 (10,700) 3.1 (1.9)	3528 (7770) 4.3 (2.7)	2724 (6000) 5.5 (3.4)	2093 (4610) 6.8 (4.2)	1326 (2920) 9.8 (6.1)		
D4B	2XF	87	75	7450 (16,420)	1.42 (4'8") 1.78 (5'10")	2.78 (9'1") 2.67 (8'9")	PS	3.2 (2.0)	6.0 (3.7)	11.1 (6.9)				
D4B LGP	1SG	87	75	7800 (17,200)	1.65 (5'5") 2.29 (7'6")	2.99 (9'10") 2.67 (8'9")	PS	3.2 (2.0)	6.0 (3.7)	11.1 (6.9)				
D4C	39A	59-63	65/52	5064 (11,155)	1.12 (3'8") 1.58 (5'2")	3.05 (10'1") 1.76 (5'10")	DD	4858 (10,700) 3.1 (1.9)	3528 (7770) 4.3 (2.7)	2724 (6000) 5.5 (3.4)	2093 (4610) 6.8 (4.2)	1321 (2910) 9.8 (6.1)		
D4C	40A	59-63	65/52	4881 (10,750)	1.52 (5'0") 1.98 (6'6")	3.05 (10'1") 1.76 (5'10")	DD	4858 (10,700) 3.1 (1.9)	3528 (7770) 4.3 (2.7)	2724 (6000) 5.5 (3.4)	2093 (4610) 6.8 (4.2)	1321 (2910) 9.8 (6.1)		
D4C	1RJ	87-90	78	7581 (16,714)	1.42 (4'7") 1.83 (6'0")	3.00 (9'10.1") 2.66 (8'8.9")	PS	3.1 (1.9)	5.9 (3.7)	11.1 (6.9)				
D4C Series II		90-93	80	7557 (16,660)	1.42 (4'8") 1.83 (6'5")		PS	3.2 (2.0)	5.9 (3.7)	11.1 (6.9)				
D4C Series III		93-01	80	7330 (16,150)	1.50 (4'11") 1.91 (6'3")	3.99 (13'1") 2.73 (8'11")	HYS		0-9.0 (0-5.6)					
D4C XL Series III		93-01	80	7520 (16,570)	1.50 (4'11") 1.96 (6'5")	3.99 (13'1") 2.73 (8'11")	HYS		0-9.0 (0-5.6)					

NOTE: Power Shift models show speeds only, not drawbar pull.

NOTE: Track-Type Tractor weights do not include blades until 1967.



Track-Type Tractors (cont'd)

Model	Product Ident. No. Prefix	Years Built	Horse-power FW/ Drawbar	Approx. Machine Weight kg (lb)	Gauge m (ft) and Width m (ft)	Length m (ft) and Height m (ft)	Transmission	Rated Drawbar Pull — kg (lb) and Forward Speed — km/h (mph)						
								1st	2nd	3rd	4th	5th	6th	
D4C LGP	2CJ	87-90	78	7905 <b>(17,427)</b>	1.65 <b>(5'4")</b> 2.29 <b>(7'6")</b>	3.00 <b>(9'10.1")</b> 2.66 <b>(8'8.9")</b>	PS							
D4C LGP Series II		90-93	80	7905 <b>(17,427)</b>	1.65 <b>(5'5")</b> 2.29 <b>(7'6")</b>		PS	3.2 <b>(2.0)</b>	5.9 <b>(3.7)</b>	11.1 <b>(6.9)</b>				
D4C LGP Series III		93-01	80	7790 <b>(17,160)</b>	1.68 <b>(5'6")</b> 2.31 <b>(7'6")</b>	3.99 <b>(13'1")</b> 2.73 <b>(8'11")</b>	HYS		0-9.0 <b>(0-5.6)</b>					
D4D	78A	63-68	65/52	5900 <b>(13,000)</b>	1.52 <b>(5'0")</b> 1.98 <b>(6'6")</b>	3.35 <b>(11'0")</b> 2.41 <b>(7'11")</b>	DD	5300 <b>(11,690)</b>	3700 <b>(8160)</b>	2560 <b>(5640)</b>	1880 <b>(4150)</b>	1350 <b>(2980)</b>		
D4D	22C	67-68	65/—	5900 <b>(13,100)</b>	1.52 <b>(5'0")</b> 1.98 <b>(6'6")</b>	3.38 <b>(11'1")</b> 2.41 <b>(7'11")</b>	PS		3.2 <b>(2.0)</b>	5.8 <b>(3.6)</b>	9.3 <b>(5.8)</b>			
D4D	82J	63	—/65	7910 <b>(17,440)</b>	1.52 <b>(5'0")</b> 1.98 <b>(6'6")</b>	3.38 <b>(11'1")</b> 2.67 <b>(8'9")</b>	DD	6150 <b>(13,550)</b>	4150 <b>(9140)</b>	2820 <b>(6210)</b>	2030 <b>(4480)</b>	1420 <b>(3120)</b>		
D4D	83J	67-71	—/65	8270 <b>(18,240)</b>	1.52 <b>(5'0")</b> 1.98 <b>(6'6")</b>	3.38 <b>(11'1")</b> 2.67 <b>(8'9")</b>	PS		3.2 <b>(2.0)</b>	5.7 <b>(3.6)</b>	9.3 <b>(5.8)</b>			
D4D	83J	72-77	—/75	5900 <b>(13,100)</b>	1.52 <b>(5'0")</b> 1.98 <b>(6'6")</b>	3.38 <b>(11'1")</b> 2.67 <b>(8'9")</b>	DD	6150 <b>(13,550)</b>	4150 <b>(9140)</b>	2820 <b>(6210)</b>	2030 <b>(4480)</b>	1420 <b>(3120)</b>		
D4E	27X	77-84	80/—	9013 <b>(19,820)</b>	1.52 <b>(5'0")</b> 2.44 <b>(8'0")</b>	3.86 <b>(12'8")</b> 2.72 <b>(8'11")</b>	DD	6495 <b>(14,320)</b>	4425 <b>(9756)</b>	3018 <b>(6654)</b>	2172 <b>(4788)</b>	1509 <b>(3327)</b>		
D4E	28X	77-84	80/—	9090 <b>(20,040)</b>	1.52 <b>(5'0")</b> 2.44 <b>(8'0")</b>	3.86 <b>(12'8")</b> 2.72 <b>(8'11")</b>	PS		3.3 <b>(2.1)</b>	5.9 <b>(3.7)</b>	9.5 <b>(5.9)</b>			
D4G XL	CFN	01-03	80	7761 <b>(17,110)</b>	1.50 <b>(4'11")</b> 1.96 <b>(6'5")</b>	4.04 <b>(13'3")</b> 2.72 <b>(8'11")</b>	HYS							
D4G XL Tier 2	HYD	03-07	80	7800 <b>(17,196)</b>	1.50 <b>(4'11")</b> 1.96 <b>(6'5")</b>	4.04 <b>(13'3")</b> 2.72 <b>(8'11")</b>	HYS		0-9.0 <b>(0-5.6)</b>					

NOTE: Power Shift models show speeds only, not drawbar pull.  
NOTE: Track-Type Tractor weights do not include blades until 1967.

## Track-Type Tractors (cont'd)

Model	Product Ident. No. Prefix	Years Built	Horse-power FW/ Drawbar	Approx. Machine Weight kg (lb)	Gauge m (ft) and Width m (ft)	Length m (ft) and Height m (ft)	Transmission	Rated Drawbar Pull — kg (lb) and Forward Speed — km/h (mph)						
								1st	2nd	3rd	4th	5th	6th	
D4G LGP	FDC	01-03	80	8109 (17,877)	1.68 (5'6") 2.31 (7'7")	4.04 (13'3") 2.72 (8'11")	HYS		0-9.0 (0-5.6)					
D4G LGP Tier 2	TLX	03-07	80	8143 (17,952)	1.68 (5'6") 2.31 (7'7")	4.04 (13'3") 2.72 (8'11")	HYS		0-9.0 (0-5.6)					
D4H (JPN)	8PB*	85-89	90/—	9975 (21,991)	1.67 (5'6") 2.13 (7'0")	3.422 (11'3") 2.933 (9'8")	PS			3.5 (2.2)	6.2 (3.9)	10.2 (6.3)		
D4H (JPN)	2AC*	85-89	90/—	10 111 (22,291)	1.67 (5'6") 2.13 (7'0")	3.422 (11'3") 2.933 (9'8")	DD	7618 (16,798)	5843 (12,884)	4333 (9554)	3207 (7071)	2335 (5149)	1640 (3617)	
D4H (JPN)	8PB*	89-90	95/—	10 105 (22,277)	1.67 (5'6") 2.13 (7'0")	3.422 (11'3") 2.933 (9'8")	PS			3.5 (2.2)	6.2 (3.9)	10.2 (6.3)		
D4H (JPN)	8PB	91-96	95/—	11 019 (24,242)	1.67 (5'6") 2.13 (7'0")	3.44 (11'3") 2.939 (9'8")	PS			3.5 (2.2)	6.2 (3.9)	10.2 (6.3)		
D4H (JPN)	2AC*	89-90	95/—	10 231 (22,555)	1.67 (5'6") 2.13 (7'0")	3.422 (11'3") 2.933 (9'8")	DD	7454 (16,434)	5715 (12,599)	4235 (9336)	3132 (6904)	2277 (5020)	1597 (3520)	
D4H (JPN)	2AC	91-96	95/—	11 019 (24,242)	1.67 (5'6") 2.13 (7'0")	3.44 (11'3") 2.939 (9'8")	DD	7454 (16,434)	5715 (12,599)	4235 (9336)	3132 (6904)	2227 (5020)	1597 (3520)	
D4H LGP (JPN)	9DB*	85-89	90/—	11 245 (24,790)	2.00 (6'7") 2.76 (9'1")	3.693 (10'4") 2.986 (9'10")	PS			3.5 (2.2)	6.2 (3.9)	10.2 (6.3)		
D4H LGP (JPN)	3AC*	85-89	90/—	11 381 (25,090)	2.00 (6'7") 2.76 (9'1")	3.693 (10'4") 2.986 (9'10")	DD	7618 (16,798)	5843 (12,884)	4333 (9554)	3207 (7071)	2335 (5149)	1640 (3617)	
D4H LGP (JPN)	9DB*	89-90	95/—	11 350 (25,022)	2.00 (6'7") 2.76 (9'1")	3.693 (10'4") 2.986 (9'10")	PS			3.5 (2.2)	6.2 (3.9)	10.2 (6.3)		
D4H LGP (JPN)	9DB	91-96	105/—	12 440 (27,368)	2.00 (6'7") 2.76 (9'1")	3.718 (12'2") 3.04 (10'0")	PS			3.4 (2.1)	6.0 (3.7)	10.2 (6.4)		

\*D4H models prior to Series II. Product identification number prefix still in use for current product.

**NOTE:** Power Shift models show speeds only, not drawbar pull.

**NOTE:** Track-Type Tractor weights do not include blades until 1967.

Track-Type Tractors (cont'd)

Model	Product Ident. No. Prefix	Years Built	Horse-power FW/ Drawbar	Approx. Machine Weight kg (lb)	Gauge m (ft) and Width m (ft)	Length m (ft) and Height m (ft)	Transmission	Rated Drawbar Pull — kg (lb) and Forward Speed — km/h (mph)					
								1st	2nd	3rd	4th	5th	6th
D4H LGP (JPN)	3AC*	89-90	95/—	11 476 (25,300)	2.00 (6'7") 2.76 (9'1")	3.693 (10'4") 2.986 (9'10")	DD	7454 (16,434) 2.5 (1.6)	5715 (12,599) 3.2 (2.0)	4235 (9336) 4.3 (2.6)	3132 (6904) 5.5 (3.4)	2277 (5020) 7.2 (4.4)	1597 (3520) 9.5 (5.9)
D4H LGP (JPN)	9GJ	92-96	105/—	12 440 (27,368)	2.00 (6'7") 2.76 (9'1")	3.718 (12'2") 3.04 (10'0")	PS	3.4 (2.1)	6.0 (3.7)	10.2 (6.4)			
D4H XL (JPN)	8PS	92-96	105/—	11 786 (25,929)	1.77 (5'10") 2.28 (7'6")	3.446 (11'4") 2.99 (9'10")	PS	3.4 (2.1)	6.0 (3.7)	10.2 (6.4)			
D5	81H	67-67	93/75	8300 (18,200)	1.52 (5'0") 2.02 (6'8")	3.89 (12'9") 2.00 (8'7")	DD	7870 (17,330) 3.8 (2.3)	4910 (10,820) 4.7 (2.9)	3330 (7320) 5.8 (3.6)	2230 (4920) 7.1 (4.4)	1440 (3170) 8.9 (5.5)	
D5	82H	67-67	93/75	8400 (18,600)	1.88 (6'2") 2.38 (7'10")	3.89 (12'9") 2.00 (8'7")	DD	7870 (17,330) 2.7 (1.7)	4910 (10,820) 4.2 (2.6)	3330 (7320) 5.8 (3.6)	2230 (4920) 8.0 (5.0)	1440 (3170) 11.1 (6.9)	
D5	83H	67-67	93/—	8500 (18,800)	1.52 (5'0") 2.02 (6'8")	3.89 (12'9") 2.64 (8'8")	PS	2.7 (1.7)	4.2 (2.6)	5.8 (3.6)	8.0 (5.0)	11.1 (6.9)	
D5	84H	67-67	93/—	8700 (19,200)	1.88 (6'2") 2.38 (7'10")	3.89 (12'9") 2.64 (8'8")	PS	3.6 (2.2)	6.1 (3.8)	10.1 (6.3)			
D5	98J	67-77	105	11 290 (24,400)	1.52 (5'0") 2.02 (6'8")	3.89 (12'9") 2.74 (9'0")	DD	8770 (19,340) 4.0 (2.5)	5500 (12,130) 4.8 (3.0)	3750 (8270) 5.6 (3.5)	2540 (5610) 6.4 (4.0)	1660 (3660) 7.4 (4.6)	9.0 (5.6)
D5	93J	67-77	105	11 290 (24,400)	1.52 (5'0") 2.02 (6'8")	3.89 (12'9") 2.74 (9'0")	DD	8770 (19,340) 2.7 (1.7)	5500 (12,130) 4.2 (2.6)	3750 (8270) 5.8 (3.6)	2540 (5610) 8.0 (5.0)	1660 (3660) 11.1 (6.9)	
D5	94J	66-77	105	11 390 (25,100)	1.88 (6'2") 2.38 (7'10")	3.89 (12'9") 2.74 (9'0")	DD	8770 (19,340) 2.7 (1.7)	5500 (12,130) 4.2 (2.6)	3750 (8270) 5.8 (3.6)	2540 (5610) 8.0 (5.0)	1660 (3660) 11.1 (6.9)	
D5	95J	66-77	105	11 290 (24,900)	1.52 (5'0") 2.02 (6'8")	3.89 (12'9") 2.74 (9'0")	PS						
D5	96J	66-77	105	11 600 (25,600)	1.88 (6'2") 2.38 (7'10")	3.89 (12'9") 2.74 (9'0")	PS						

\*D4H models prior to Series II. Product identification number prefix still in use for current product.

NOTE: Power Shift models show speeds only, not drawbar pull.

NOTE: Track-Type Tractor weights do not include blades until 1967.

## Track-Type Tractors (cont'd)

Model	Product Ident. No. Prefix	Years Built	Horse-power FW/ Drawbar	Approx. Machine Weight kg (lb)	Gauge m (ft) and Width m (ft)	Length m (ft) and Height m (ft)	Transmission	Rated Drawbar Pull — kg (lb) and Forward Speed — km/h (mph)					
								1st	2nd	3rd	4th	5th	6th
D5B	25X	77-84	105/—	11 619 (25,615)	1.88 (6'2") 3.15 (10'4")	4.60 (15'1") 2.77 (9'1")	PS	3.5 (2.2)	6.1 (3.8)	10.1 (6.3)			
D5B	23X	77-82	105/—	11 283 (24,875)	1.88 (6'2") 3.15 (10'4")	4.60 (15'1") 2.77 (9'1")	DD	8060 (17,770)	5030 (11,100)	3410 (7520)	2290 (5060)	1480 (3260)	
D5C		91-93	90	8460 (18,650)	1.54 (5'1") 2.01 (6'7")		PS	3.5 (2.2)	6.3 (3.9)	10.0 (6.2)			
D5C Series III		93-01	90	8490 (18,710)	1.55 (5'1") 2.00 (6'7")	4.07 (13'4") 2.74 (9'0")	HYS		0-9.0 (0-5.6)				
D5C XL Series III		93-01	90	8820 (19,450)	1.55 (5'1") 2.06 (6'9")	4.32 (14'2") 2.74 (9'0")	HYS		0-9.0 (0-5.6)				
D5C LGP		91-93	90	8987 (19,800)	1.72 (5'8") 2.38 (7'10")		PS	3.5 (2.2)	6.3 (3.9)	10.0 (6.2)			
D5C LGP Series III		93-01	90	8970 (19,780)	1.73 (5'8") 2.39 (7'10")	4.07 (13'4") 2.74 (9'0")	HYS		0-9.0 (0-5.6)				
D5E		-99	105	11 700 (25,800)	1.52 (5'0")	3.88 (12'8")	DD	8770 (19,340)	5500 (12,130)	3750 (8270)	2450 (5600)	1660 (3660)	
D5G XL	FDH	01-03	90	8863 (19,540)	1.55 (5'1") 2.06 (6'9")	4.34 (14'3") 2.73 (8'11")	HYS		0-9.0 (0-5.6)				
D5G XL Tier 2	WGB	03-07	90	8919 (19,662)	1.55 (5'1") 2.06 (6'9")	4.34 (14'3") 2.73 (8'11")	HYS		0-9.0 (0-5.6)				
D5G LGP	FDW	01-03	90	9207 (20,298)	1.73 (5'8") 2.39 (7'10")	4.25 (13'11") 2.73 (8'11")	HYS		0-9.0 (0-5.6)				
D5G LGP Tier 2	RKG	03-07	90	9269 (20,434)	1.73 (5'8") 2.39 (7'10")	4.25 (13'11") 2.73 (8'11")	HYS		0-9.0 (0-5.6)				

**NOTE:** Power Shift models show speeds only, not drawbar pull.

**NOTE:** Track-Type Tractor weights do not include blades until 1967.

Track-Type Tractors (cont'd)

Model	Product Ident. No. Prefix	Years Built	Horse-power FW/ Drawbar	Approx. Machine Weight kg (lb)	Gauge m (ft) and Width m (ft)	Length m (ft) and Height m (ft)	Transmission	Rated Drawbar Pull — kg (lb) and Forward Speed — km/h (mph)						
								1st	2nd	3rd	4th	5th	6th	
D5H (FR)	8RC*	85-90	120/—	12 144 (26,772)	1.8 (5'11") 2.21 (7'3")	3.6 (11'10") 2.93 (9'7")	PS	— 3.3 (2.1)	— 5.9 (3.7)	— 10.0 (6.2)				
D5H (FR)	8RC	91-96	120/—	13 250 (29,200)	1.8 (5'11") 2.31 (7'7")	3.6 (11'10") 3.0 (9'10")	DD		3.3 (2.1)	5.9 (3.7)	10.0 (6.2)			
D5H (FR)	7NC*	85-90	120/—	12 212 (26,922)	1.8 (5'11") 2.21 (7'3")	3.6 (11'10") 2.93 (9'7")	DD	9140 (20,150)	7005 (15,440)	5190 (11,440)	3835 (8450)	2785 (6140)	1950 (4300)	
D5H (FR)	7NC	91-96	120/—	13 250 (29,200)	1.8 (5'11") 2.31 (7'7")	3.6 (11'10") 3.0 (9'10")	DD	9140 (20,150)	7005 (15,440)	5190 (11,440)	3835 (8450)	2785 (6140)	1950 (4300)	
D5H LGP (FR)	1DD*	86-90	120/—	14 685 (32,380)	2.16 (7'1") 3.02 (9'11")	4.129 (13'7") 3.069 (10'1")	PS		3.3 (2.1)	5.9 (3.7)	10.0 (6.2)			
D5H LGP (FR)	1DD	91-96	130/—	16 200 (35,700)	2.16 (7'1") 3.02 (9'11")	4.133 (13'7") 3.135 (10'3")	PS		3.3 (2.1)	5.9 (3.7)	10.0 (6.2)			
D5H LGP (FR)	9HC*	85-90	120/—	14 878 (32,800)	2.16 (7'1") 3.02 (9'11")	4.129 (13'7") 3.069 (10'1")	DD	9140 (20,150)	7005 (15,440)	5190 (11,440)	3835 (8450)	2785 (6140)	1950 (4300)	
D5H LGP (FR)	9HC	91-96	130/—	16 200 (35,700)	2.16 (7'1") 3.02 (9'11")	4.133 (13'7") 3.135 (10'3")	DD	10 061 (22,181)	7725 (17,031)	5738 (12,650)	4256 (9384)	3109 (6855)	2195 (4840)	
D5H (JPN)	3MD*	86-90	120/—	12 144 (26,772)	1.8 (5'11") 2.21 (7'3")	3.6 (11'10") 2.93 (9'7")	PS		3.3 (2.1)	5.9 (3.7)	10.0 (6.2)			
D5H (JPN)	3MD	91-96	120/—	13 250 (29,200)	1.8 (5'11") 2.31 (7'7")	3.6 (11'10") 3.0 (9'10")	PS		3.3 (2.1)	5.9 (3.7)	10.0 (6.2)			
D5H (JPN)	1YD*	86-90	120/—	12 212 (26,922)	1.8 (5'11") 2.21 (7'3")	3.6 (11'10") 2.93 (9'7")	DD	9140 (20,150)	7005 (15,440)	5190 (11,440)	3835 (8450)	2785 (6140)	1950 (4300)	
								2.7 (1.7)	3.4 (2.1)	4.5 (2.8)	5.8 (3.6)	7.6 (4.7)	10.0 (6.2)	

\*D5H models prior to Series II. Product identification number prefix still in use for current product.

NOTE: Power Shift models show speeds only, not drawbar pull.

NOTE: Track-Type Tractor weights do not include blades until 1967.

## Track-Type Tractors (cont'd)

Model	Product Ident. No. Prefix	Years Built	Horse-power FW/ Drawbar	Approx. Machine Weight kg (lb)	Gauge m (ft) and Width m (ft)	Length m (ft) and Height m (ft)	Transmission	Rated Drawbar Pull — kg (lb) and Forward Speed — km/h (mph)					
								1st	2nd	3rd	4th	5th	6th
D5H (JPN)	1YD*	91-96	120/—	13 250 (29,200)	1.8 (5'11") 2.31 (7'7")	3.6 (11'10") 3.0 (9'10")	DD	9140 (20,150) 2.7 (1.7)	7005 (15,440) 3.4 (2.1)	5190 (11,440) 4.5 (2.8)	3835 (8450) 5.8 (3.6)	2785 (6140) 7.6 (4.7)	1950 (4300) 10.0 (6.2)
D5H LGP (JPN)	4KD*	86-90	120/—	14 685 (32,380)	2.16 (7'1") 3.02 (9'11")	4.129 (13'7") 3.069 (10'1")	PS	3.3 (2.1)	5.9 (3.6)	10.0 (6.2)			
D5H LGP (JPN)	4KD	91-96	130/—	16 200 (35,700)	2.16 (7'1") 3.02 (9'11")	4.133 (13'7") 3.135 (10'3")	PS	3.3 (2.1)	5.9 (3.7)	10.0 (6.2)			
D5H LGP (JPN)	2SD*	86-90	120/—	14 878 (32,800)	2.16 (7'1") 3.02 (9'11")	4.129 (13'7") 3.069 (10'1")	DD	9140 (20,150) 2.7 (1.7)	7005 (15,440) 3.4 (2.1)	5190 (11,440) 4.5 (2.8)	3835 (8450) 5.8 (3.6)	2785 (6140) 7.6 (4.7)	1950 (4300) 10.0 (6.2)
D5H LGP (JPN)	2SD	91-96	130/—	16 200 (35,700)	2.16 (7'1") 3.02 (9'11")	4.133 (13'7") 3.135 (10'3")	DD	10 061 (22,181) 2.6 (1.6)	7725 (17,031) 3.4 (2.1)	5738 (12,650) 4.5 (2.7)	4256 (9384) 5.8 (3.6)	3109 (6855) 7.5 (4.7)	2195 (4840) 9.9 (6.2)
D5H XL (FR)	8RJ	92-96	130/—	13 900 (30,600)	1.89 (6'2") 2.49 (8'2")	3.606 (11'10") 3.08 (9'11")	PS	3.3 (2.1)	5.9 (3.7)	10.0 (6.2)			
D5M XL (FR)	4BR	96-02	82/110	12 250 (27,006)	1.77 (5'10") 2.33** (7'8")**	3.544 (11'8") 3.002*** (9'10")***	PS	22 347 (49,264) 3.27 (2.03)	12 166 (26,821) 5.81 (3.61)	6745 (14,870) 9.93 (6.17)			
D5M XL (FR)	6GN	96-02	82/110	12 250 (27,006)	1.77 (5'10") 2.33** (7'8")**	3.544 (11'8") 3.002*** (9'10")***	PS	22 347 (49,264) 3.27 (2.03)	12 166 (26,821) 5.81 (3.61)	6745 (14,870) 9.93 (6.17)			
D5M LGP (FR)	3DR	96-02	82/110	13 100 (28,880)	2.00 (6'7") 2.76** (9'1")**	3.72 (12'2") 3.046*** (10'0")***	PS	22 347 (49,264) 3.27 (2.03)	12 166 (26,821) 5.81 (3.61)	6745 (14,870) 9.93 (6.17)			
D5M LGP (FR)	3CR	96-02	82/110	13 100 (28,880)	2.00 (6'7") 2.76** (9'1")**	3.72 (12'2") 3.046*** (10'0")***	PS	22 347 (49,264) 3.27 (2.03)	12 166 (26,821) 5.81 (3.61)	6745 (14,870) 9.93 (6.17)			

\*D5H models prior to Series II. Product identification number prefix still in use for current product.

\*\*Width without blade and with standard shoes.

\*\*\*Height with ROPS cab.

NOTE: Power Shift models show speeds only, not drawbar pull.

NOTE: Track-Type Tractor weights do not include blades until 1967.

Track-Type Tractors (cont'd)

Model	Product Ident. No. Prefix	Years Built	Horse-power FW/ Drawbar	Approx. Machine Weight kg (lb)	Gauge m (ft) and Width m (ft)	Length m (ft) and Height m (ft)	Transmission	Rated Drawbar Pull — kg (lb) and Forward Speed — km/h (mph)						
								1st	2nd	3rd	4th	5th	6th	
D6	4R	47-59	85	8042 <b>(17,730)</b>	1.88 <b>(6'2")</b> 1.52 <b>(5'0")</b>	3.75 <b>(12'4")</b> 1.91 <b>(6'3")</b>	DD	8618 <b>(19,000)</b> 2.7 <b>(1.7)</b>	5534 <b>(12,200)</b> 4.2 <b>(2.6)</b>	3837 <b>(8460)</b> 5.8 <b>(3.6)</b>	2617 <b>(5770)</b> 8.0 <b>(5.0)</b>	1842 <b>(4060)</b> 10.6 <b>(6.6)</b>		
D6	9U	47-59	93/75	8153 <b>(17,975)</b>	1.88 <b>(6'2")</b> 1.52 <b>(5'0")</b>	3.75 <b>(12'4")</b> 1.91 <b>(6'3")</b>	DD	8618 <b>(19,000)</b> 2.7 <b>(1.7)</b>	5534 <b>(12,200)</b> 4.2 <b>(2.6)</b>	3837 <b>(8460)</b> 5.8 <b>(3.6)</b>	2617 <b>(5770)</b> 8.0 <b>(5.0)</b>	1842 <b>(4060)</b> 10.6 <b>(6.6)</b>		
D6B	37A	59-67	93/75	8130 <b>(17,930)</b>	1.52 <b>(5'0")</b> 2.02 <b>(6'8")</b>	3.85 <b>(12'9")</b> 1.91 <b>(6'3")</b>	DD							
D6B	44A	59-67	93/75	8300 <b>(18,300)</b>	1.88 <b>(6'2")</b> 2.38 <b>(7'10")</b>	3.85 <b>(12'9")</b> 1.91 <b>(6'3")</b>	DD	7820 <b>(16,240)</b> 2.7 <b>(1.7)</b>	4940 <b>(10,900)</b> 4.2 <b>(2.6)</b>	3220 <b>(7090)</b> 6.0 <b>(3.7)</b>	2120 <b>(4670)</b> 8.4 <b>(5.2)</b>	1450 <b>(3190)</b> 10.9 <b>(6.8)</b>		
D6C	74A	63-67	120	10 400 <b>(23,000)</b>	1.88 <b>(6'2")</b> 2.38 <b>(7'9")</b>	3.95 <b>(13'0")</b> 1.92 <b>(6'4")</b>	DD	12 050 <b>(26,540)</b> 2.4 <b>(1.5)</b>	8020 <b>(17,670)</b> 3.4 <b>(2.1)</b>	5300 <b>(11,690)</b> 4.8 <b>(3.0)</b>	3360 <b>(7400)</b> 6.8 <b>(4.2)</b>	2030 <b>(4470)</b> 9.5 <b>(5.9)</b>		
D6C	76A	63-67	120	10 700 <b>(23,500)</b>	1.88 <b>(6'2")</b> 2.38 <b>(7'9")</b>	3.95 <b>(13'0")</b> 1.92 <b>(6'4")</b>	PS							
D6C	10K	67-76	140	13 880 <b>(30,600)</b>	1.88 <b>(6'2")</b> 2.38 <b>(7'9")</b>	3.73 <b>(12'3")</b> 2.87 <b>(9'5")</b>	PS							
D6 LGP	69U	72-77	140	17 010 <b>(37,500)</b>	2.11 <b>(6'11")</b> 3.02 <b>(9'11")</b>	3.94 <b>(12'11")</b> 2.97 <b>(9'9")</b>	PS							
D6C	99J	67-76	140	14 243 <b>(31,400)</b>	1.88 <b>(6'2")</b> 2.38 <b>(7'9")</b>	3.73 <b>(12'3")</b> 2.87 <b>(9'5")</b>	DD	11 500 <b>(25,360)</b> 2.7 <b>(1.7)</b>	7750 <b>(17,090)</b> 4.0 <b>(2.5)</b>	5180 <b>(11,420)</b> 5.6 <b>(3.5)</b>	3350 <b>(7380)</b> 7.9 <b>(4.9)</b>	2090 <b>(4610)</b> 11.1 <b>(6.9)</b>		
D6C LGP	69U	72-77	140	13 835 <b>(30,500)</b>	2.11 <b>(6'11")</b> 3.02 <b>(9'11")</b>	2.97 <b>(9'9")</b> 3.94 <b>(12'11")</b>	PS							

NOTE: Power Shift models show speeds only, not drawbar pull.  
NOTE: Track-Type Tractor weights do not include blades until 1967.

## Track-Type Tractors (cont'd)

Model	Product Ident. No. Prefix	Years Built	Horse-power FW/ Drawbar	Approx. Machine Weight kg (lb)	Gauge m (ft) and Width m (ft)	Length m (ft) and Height m (ft)	Transmission	Rated Drawbar Pull — kg (lb) and Forward Speed — km/h (mph)						
								1st	2nd	3rd	4th	5th	6th	
D6D	3X	77-86	140	14 290 (31,500)	1.88 (6'2") 2.36 (7'9")	3.73 (12'3") 3.06 (10'0")	DD	11 500 (25,360)	7750 (17,090)	5180 (11,420)	3350 (7380)	2090 (4610)		
D6D	4X	77-86	140	14 290 (31,500)	1.88 (6'2")	3.73 (12'3")	PS	4.0 (2.5)	6.9 (4.3)	10.8 (6.7)				
D6D LGP	6X	77-86	140	17 370 (38,300)	2.1 (6'11") 3.02 (9'11")	3.94 (12'1") 3.06 (10'0")	PS	4.0 (2.5)	6.9 (4.3)	10.8 (6.7)				
D6H	4RC*	85-90	165/—	16 950 (37,367)	1.88 (6'2") 2.64 (8'8")	4.069 (13'4") 3.114 (10'3")	PS	3.8 (2.4)	6.5 (4.0)	11.3 (7.0)				
D6H	8KB	85-88	165/—	16 954 (37,377)	1.88 (6'2") 2.64 (8'8")	4.069 (13'4") 3.114 (10'3")	DD	12 500 (27,560)	9520 (20,990)	7140 (15,740)	5440 (11,990)	4010 (8840)	2820 (6220)	
D6H	3ZF*	88-90	165/—	17 055 (37,599)	1.88 (6'2") 2.64 (8'8")	4.069 (13'4") 3.114 (10'3")	PS/DS	3.8 (2.4)	6.5 (4.0)	11.3 (7.0)				
D6H LGP	6FC*	87-90	165/—	19 555 (43,111)	2.225 (7'4") 3.43 (11'3")	4.493 (14'9") 3.164 (10'5")	PS	3.8 (2.4)	6.5 (4.0)	11.3 (7.0)				
D6H LGP	3YG*	88-90	165/—	19 527 (43,049)	2.225 (7'4") 3.43 (11'3")	4.493 (14'9") 3.164 (10'5")	PS/DS	3.8 (2.4)	6.5 (4.0)	11.3 (7.0)				
D6H (JPN)	2KD*	86-90	165/—	16 950 (37,367)	1.88 (6'2") 2.64 (8'8")	4.069 (13'4") 3.114 (10'3")	PS	3.8 (2.4)	6.5 (4.0)	11.3 (7.0)				
D6H (DS)	32F (E. Peoria) 4YF (Sagami) 6CF (Grenoble)	92-96	123/165	18 111 (39,928)	1.88 (6'2") 3.36 (11'0")	4.07 (13'4") 3.12 (10'3")	PS	3.8 (2.3)	6.6 (4.1)	11.4 (7.1)				

\*D6H models prior to Series II. Product identification number prefix still in use for current product.

**NOTE:** Power Shift models show speeds only, not drawbar pull.

**NOTE:** Track-Type Tractor weights do not include blades until 1967.



Track-Type Tractors (cont'd)

Model	Product Ident. No. Prefix	Years Built	Horse-power FW/ Drawbar	Approx. Machine Weight kg (lb)	Gauge m (ft) and Width m (ft)	Length m (ft) and Height m (ft)	Transmission	Rated Drawbar Pull — kg (lb) and Forward Speed — km/h (mph)						
								1st	2nd	3rd	4th	5th	6th	
D6H (CB)	4RC	92-96	123/165	17 997 <b>(39,676)</b>	1.88	4.07	PS	3.8 <b>(2.3)</b>	6.6 <b>(4.1)</b>	11.4 <b>(7.1)</b>				
	(E. Peoria) 2KD				(6'2")	(13'4")					3.36	3.12		
	(Sagami) 4LG (Grenoble)				(11'0")	(10'3")								
D6H XL (DS)	9KJ	92-96	130/175	19 080 <b>(42,063)</b>	1.88	4.07	PS	3.8 <b>(2.3)</b>	6.6 <b>(4.1)</b>	11.4 <b>(7.1)</b>				
	(E. Peoria) 8SK				(6'2")	(13'4")					3.36	3.12		
	(Sagami) 9LK (Grenoble)				(11'0")	(10'3")								
D6H XL (CB)	8ZJ	92-96	130/175	18 966 <b>(41,811)</b>	1.88	4.07	PS	3.8 <b>(2.3)</b>	6.6 <b>(4.1)</b>	11.4 <b>(7.1)</b>				
	(E. Peoria) 9RK				(6'2")	(13'4")					3.36	3.12		
	(Sagami) 8KK (Grenoble)				(11'0")	(10'3")								
D6H XR (DS)	6CK	92-96	130/175	18 799 <b>(41,444)</b>	1.88	4.22	PS	3.8 <b>(2.3)</b>	6.6 <b>(4.1)</b>	11.4 <b>(7.1)</b>				
	(E. Peoria) 2TL				(6'2")	(13'10")					3.36	3.12		
	(Sagami) 1YL (Grenoble)				(11'0")	(10'3")								
D6H XR (CB)	5KK	92-96	130/175	18 799 <b>(41,444)</b>	1.88	4.22	PS	3.8 <b>(2.3)</b>	6.6 <b>(4.1)</b>	11.4 <b>(7.1)</b>				
	(E. Peoria) 7ZK				(6'2")	(13'10")					3.36	3.12		
	(Sagami) 2BL (Grenoble)				(11'0")	(10'3")								
D6H LGP (DS)	3YG	92-96	134/180	20 486 <b>(45,163)</b>	2.24	4.49	PS	3.8 <b>(2.3)</b>	6.6 <b>(4.1)</b>	11.4 <b>(7.1)</b>				
	(E. Peoria) 4GG				(7'3")	(14'9")					4.0	3.17		
	(Sagami) 5HF (Grenoble)				(13'1")	(10'5")								
D6H LGP (CB)	6FC	92-96	134/180	20 486 <b>(45,163)</b>	2.24	4.49	PS	3.8 <b>(2.3)</b>	6.6 <b>(4.1)</b>	11.4 <b>(7.1)</b>				
	(E. Peoria) 1KD				(7'3")	(14'9")					4.0	3.17		
	(Sagami) 2TG (Grenoble)				(13'1")	(10'5")								
D6H (JPN)	3ED*	86-92	165/—	16 954 <b>(37,377)</b>	1.88	4.069	DD	12 500 <b>(27,560)</b>	9520 <b>(20,990)</b>	7140 <b>(15,740)</b>	5440 <b>(11,990)</b>	4010 <b>(8840)</b>	2820 <b>(6220)</b>	
					2.64 <b>(8'8")</b>	3.114 <b>(10'3")</b>		2.7 <b>(1.7)</b>	3.5 <b>(2.2)</b>	4.6 <b>(2.9)</b>	5.8 <b>(3.6)</b>	7.6 <b>(4.7)</b>	10.0 <b>(6.2)</b>	
D6H (JPN)	4YF*	88-90	165/—	17 055 <b>(37,599)</b>	1.88	4.069	PS/DS	3.8 <b>(2.4)</b>	6.5 <b>(4.0)</b>	11.3 <b>(7.0)</b>				
					2.64 <b>(8'8")</b>	3.114 <b>(10'3")</b>								

\*D6H models prior to Series II. Product identification number prefix still in use for current product.

NOTE: Power Shift models show speeds only, not drawbar pull.

NOTE: Track-Type Tractor weights do not include blades until 1967.

## Track-Type Tractors (cont'd)

Model	Product Ident. No. Prefix	Years Built	Horse-power FW/ Drawbar	Approx. Machine Weight kg (lb)	Gauge m (ft) and Width m (ft)	Length m (ft) and Height m (ft)	Transmission	Rated Drawbar Pull — kg (lb) and Forward Speed — km/h (mph)						
								1st	2nd	3rd	4th	5th	6th	
D6H LGP (JPN)	1KD*	86-90	165/—	19 555 (43,111)	2.225 (7'4") 3.43 (11'3")	4.493 (14'9") 3.164 (10'5")	PS	3.8 (2.4)	6.5 (4.0)	11.3 (7.0)				
D6H LGP (JPN)	8FC*	86-90	165/—	19 676 (43,380)	2.225 (7'4") 3.43 (11'3")	4.485 (14'9") 3.164 (10'5")	DD	12 500 (27,560)	9520 (20,990)	7140 (15,740)	5440 (11,990)	4010 (8840)	2820 (6220)	
D6H LGP (JPN)	4GG*	88-90	165/—	19 527 (43,049)	2.225 (7'4") 3.43 (11'3")	4.493 (14'9") 3.164 (10'5")	PS/DS	3.8 (2.4)	6.5 (4.0)	11.3 (7.0)				
D6H (FR)	4LG*	87-90	165/—	16 950 (37,367)	1.88 (6'2") 2.64 (8'8")	4.069 (13'4") 3.114 (10'3")	PS	3.8 (2.4)	6.5 (4.0)	11.3 (7.0)				
D6H (FR)	1FJ*	88-90	165/—	16 954 (37,377)	1.88 (6'2") 2.64 (8'8")	4.069 (13'4") 3.114 (10'3")	DD	12 500 (27,560)	9520 (20,990)	7140 (15,740)	5440 (11,990)	4010 (8840)	2820 (6220)	
D6H (FR)	6CF*	88-90	165/—	17 055 (37,599)	1.88 (6'2") 2.64 (8'8")	4.069 (13'4") 3.114 (10'3")	PS/DS	3.8 (2.4)	6.5 (4.0)	11.3 (7.0)				
D6H LGP (FR)	2TG*	87-90	165/—	19 555 (43,111)	2.225 (7'4") 3.43 (11'3")	4.493 (14'9") 3.164 (10'5")	PS	3.8 (2.4)	6.5 (4.0)	11.3 (7.0)				
D6H LGP (FR)	5HF*	88-90	165/—	19 527 (43,049)	2.225 (7'4") 3.43 (11'3")	4.493 (14'9") 3.164 (10'5")	PS/DS	3.8 (2.4)	6.5 (4.0)	11.3 (7.0)				
D6H (SCOT)	7PC	86-87	165/—	16 950 (37,367)	1.88 (6'2") 2.64 (8'8")	4.069 (13'4") 3.114 (10'3")	PS	3.8 (2.4)	6.5 (4.0)	11.3 (7.0)				
D6H LGP (SCOT)	8YC	86-87	165/—	19 555 (43,111)	2.225 (7'4") 3.43 (11'3")	4.493 (14'9") 3.164 (10'5")	PS	3.8 (2.4)	6.5 (4.0)	11.3 (7.0)				
D6R STD CB (US)	2YN	95-02	165/—	18 100 (40,000)	1.88 (6'2") 2.64 (8'8")	4.08 (13'4") 3.20 (10'6")	PS	4.0 (2.5)	7.1 (4.4)	12.4 (7.7)				
D6R STD CB (BRAZIL)	9ZS	97-02	165/—	18 100 (40,000)	1.88 (6'2") 2.64 (8'8")	4.08 (13'4") 3.20 (10'6")	PS	4.0 (2.5)	7.1 (4.4)	12.4 (7.7)				

\*D6H models prior to Series II. Product identification number prefix still in use for current product.

**NOTE:** Power Shift models show speeds only, not drawbar pull.

**NOTE:** Track-Type Tractor weights do not include blades until 1967.

Track-Type Tractors (cont'd)

Model	Product Ident. No. Prefix	Years Built	Horse-power FW/ Drawbar	Approx. Machine Weight kg (lb)	Gauge m (ft) and Width m (ft)	Length m (ft) and Height m (ft)	Transmission	Rated Drawbar Pull — kg (lb) and Forward Speed — km/h (mph)						
								1st	2nd	3rd	4th	5th	6th	
D6R STD CB (FRANCE)	2HM	96-01	165/—	18 100 (40,000)	1.88 (6'2")	4.08 (13'4")	PS	4.0 (2.5)	7.1 (4.4)	12.4 (7.7)				
					2.64 (8'8")	3.20 (10'6")								
D6R STD CB (JAPAN)	6FR	96-02	165/—	18 100 (40,000)	1.88 (6'2")	4.08 (13'4")	PS	4.0 (2.5)	7.1 (4.4)	12.4 (7.7)				
					2.64 (8'8")	3.20 (10'6")								
D6R STD DS (US)	3ZN	95-02	165/—	18 300 (40,400)	1.88 (6'2")	4.08 (13'4")	PS	3.9 (2.4)	6.8 (4.2)	11.9 (7.6)				
					2.64 (8'8")	3.20 (10'6")								
D6R STD DS (BRAZIL)	1RW	97-02	165/—	18 300 (40,400)	1.88 (6'2")	4.08 (13'4")	PS	3.9 (2.4)	6.8 (4.2)	11.9 (7.6)				
					2.64 (8'8")	3.20 (10'6")								
D6R STD DS (FRANCE)	4FM	96-01	165/—	18 300 (40,400)	1.88 (6'2")	4.08 (13'4")	PS	3.9 (2.4)	6.8 (4.2)	11.9 (7.6)				
					2.64 (8'8")	3.20 (10'6")								
D6R STD DS (JAPAN)	5PR	97-02	165/—	18 300 (40,400)	1.88 (6'2")	4.08 (13'4")	PS	3.9 (2.4)	6.8 (4.2)	11.9 (7.6)				
					2.64 (8'8")	3.20 (10'6")								
D6R XL CB (US)	4MN	96-02	175/—	19 000 (41,900)	1.88 (6'2")	4.08 (13'4")	PS	4.0 (2.5)	7.1 (4.4)	12.4 (7.7)				
					2.64 (8'8")	3.20 (10'6")								
D6R XL CB (BRAZIL)	6MR	97-02	175/—	19 000 (41,900)	1.88 (6'2")	4.08 (13'4")	PS	4.0 (2.5)	7.1 (4.4)	12.4 (7.7)				
					2.64 (8'8")	3.20 (10'6")								
D6R XL CB (FRANCE)	4JR	96-01	175/—	19 000 (41,900)	1.88 (6'2")	4.08 (13'4")	PS	4.0 (2.5)	7.1 (4.4)	12.4 (7.7)				
					2.64 (8'8")	3.20 (10'6")								
D6R XL CB (JAPAN)	4WR	97-02	175/—	19 000 (41,900)	1.88 (6'2")	4.08 (13'4")	PS	4.0 (2.5)	7.1 (4.4)	12.4 (7.7)				
					2.64 (8'8")	3.20 (10'6")								
D6R XL DS (US)	5LN	95-02	175/—	19 200 (42,300)	1.88 (6'2")	4.08 (13'4")	PS	3.9 (2.4)	6.8 (4.2)	11.9 (7.6)				
					2.64 (8'8")	3.20 (10'6")								
D6R XL DS (BRAZIL)	7GR	96-02	175/—	19 200 (42,300)	1.88 (6'2")	4.08 (13'4")	PS	3.9 (2.4)	6.8 (4.2)	11.9 (7.6)				
					2.64 (8'8")	3.20 (10'6")								

NOTE: Power Shift models show speeds only, not drawbar pull.  
 NOTE: Track-Type Tractor weights do not include blades until 1967.

## Track-Type Tractors (cont'd)

Model	Product Ident. No. Prefix	Years Built	Horse-power FW/ Drawbar	Approx. Machine Weight kg (lb)	Gauge m (ft) and Width m (ft)	Length m (ft) and Height m (ft)	Transmission	Rated Drawbar Pull — kg (lb) and Forward Speed — km/h (mph)					
								1st	2nd	3rd	4th	5th	6th
D6R XL DS (FRANCE)	9BM	96-01	175/—	19 200 (42,300)	1.88 (6'2") 2.64 (8'8")	4.08 (13'4") 3.20 (10'6")	PS	3.9 (2.4)	6.8 (4.2)	11.9 (7.6)			
D6R XL DS (JAPAN)	5RR	97-02	175/—	19 200 (42,300)	1.88 (6'2") 2.64 (8'8")	4.08 (13'4") 3.20 (10'6")	PS	3.9 (2.4)	6.8 (4.2)	11.9 (7.6)			
D6R XR CB (US)	6JN	95-02	175/—	18 780 (41,400)	1.88 (6'2") 2.64 (8'8")	4.22 (13'10") 3.19 (10'5")	PS	4.0 (2.5)	7.1 (4.4)	12.4 (7.7)			
D6R XR CB (FRANCE)	8XN	97-01	175/—	18 780 (41,400)	1.88 (6'2") 2.64 (8'8")	4.22 (13'10") 3.19 (10'5")	PS	4.0 (2.5)	7.1 (4.4)	12.4 (7.7)			
D6R XR CB (JAPAN)	6HR	97-02	175/—	18 780 (41,400)	1.88 (6'2") 2.64 (8'8")	4.22 (13'10") 3.19 (10'5")	PS	4.0 (2.5)	7.1 (4.4)	12.4 (7.7)			
D6R XR DS (US)	7KN	95-02	175/—	18 910 (41,700)	1.88 (6'2") 2.64 (8'8")	4.22 (13'10") 3.19 (10'5")	PS	3.9 (2.4)	6.8 (4.2)	11.9 (7.6)			
D6R XR DS (FRANCE)	9MN	97-01	175/—	18 910 (41,700)	1.88 (6'2") 2.64 (8'8")	4.22 (13'10") 3.19 (10'5")	PS	3.9 (2.4)	6.8 (4.2)	11.9 (7.6)			
D6R XR DS (JAPAN)	7DR	97-02	175/—	18 910 (41,700)	1.88 (6'2") 2.64 (8'8")	4.22 (13'10") 3.19 (10'5")	PS	3.9 (2.4)	6.8 (4.2)	11.9 (7.6)			
D6R LGP CB (US)	8LN	95-02	185/—	20 500 (45,200)	2.23 (7'3") 3.43 (11'3")	4.24 (13'11") 3.19 (10'5")	PS	4.0 (2.5)	7.1 (4.4)	12.4 (7.7)			
D6R LGP CB (FRANCE)	4HN	97-01	185/—	20 500 (45,200)	2.23 (7'3") 3.43 (11'3")	4.24 (13'11") 3.19 (10'5")	PS	4.0 (2.5)	7.1 (4.4)	12.4 (7.7)			
D6R LGP CB (JAPAN)	7AR	97-01	185/—	20 500 (45,200)	2.23 (7'3") 3.43 (11'3")	4.24 (13'11") 3.19 (10'5")	PS	4.0 (2.5)	7.1 (4.4)	12.4 (7.7)			
D6R LGP DS (US)	9PN	95-02	185/—	20 680 (45,600)	2.23 (7'3") 3.43 (11'3")	4.24 (13'11") 3.19 (10'5")	PS	3.9 (2.4)	6.8 (4.2)	11.9 (7.6)			

NOTE: Power Shift models show speeds only, not drawbar pull.

NOTE: Track-Type Tractor weights do not include blades until 1967.

Track-Type Tractors (cont'd)

Model	Product Ident. No. Prefix	Years Built	Horse-power FW/ Drawbar	Approx. Machine Weight kg (lb)	Gauge m (ft) and Width m (ft)	Length m (ft) and Height m (ft)	Transmission	Rated Drawbar Pull — kg (lb) and Forward Speed — km/h (mph)					
								1st	2nd	3rd	4th	5th	6th
D6R LGP DS (FRANCE)	8TM	96-01	185/—	20 680 (45,600)	2.23 (7'3") 3.43 (11'3")	4.24 (13'11") 3.19 (10'5")	PS	3.9 (2.4)	6.8 (4.2)	11.9 (7.6)			
D6R LGP DS (JAPAN)	4TR	96-02	185/—	20 680 (45,600)	2.23 (7'3") 3.43 (11'3")	4.24 (13'11") 3.19 (10'5")	PS	3.9 (2.4)	6.8 (4.2)	11.9 (7.6)			
D6R LGP DD (JAPAN)	6GR	95-02	185/—	20 680 (45,600)	2.23 (7'3") 3.43 (11'3")	4.24 (13'11") 3.19 (10'5")	PS	3.4 (2.1)	5.9 (3.7)	10.4 (6.5)			
D6M XL (FR)	9ZM	96-02	104/140	15 530 (34,240)	1.89 (6'2") 2.49* (8'2")*	3.74 (12'3") 3.08** (10'1")**	PS	30 493 (67,222)	16 643 (36,689)	9211 (20,306)			
D6M XL (FR)	3WN	96-02	104/140	15 530 (34,240)	1.89 (6'2") 2.49* (8'2")*	3.74 (12'3") 3.08** (10'1")**	PS	30 493 (67,222)	16 643 (36,689)	9211 (20,306)			
D6M LGP (FR)	2RN	96-02	104/140	16 930 (37,320)	2.16 (7'1") 3.02* (9'11")*	4.146 (13'7") 3.194** (10'6")**	PS	30 493 (67,222)	16 643 (36,689)	9211 (20,306)			
D6M LGP (FR)	4JN	96-02	104/140	16 930 (37,320)	2.16 (7'1") 3.02* (9'11")*	4.146 (13'7") 3.194** (10'6")**	PS	30 493 (67,222)	16 643 (36,689)	9211 (20,306)			
D6R SII STD CB (FTC) (US)	AEM	02-05	123/165	17 826 (39,300)	1.88 (6'2") 2.64 (8'8")	3.86 (12'8") 3.2 (10'6")	PS	3.8 (2.4)	6.6 (4.1)	11.5 (7.2)			
D6R SII STD CB (FTC) (BRAZIL)	BRJ	02-06	123/165	17 826 (39,300)	1.88 (6'2") 2.64 (8'8")	3.86 (12'8") 3.2 (10'6")	PS	3.8 (2.4)	6.6 (4.1)	11.5 (7.2)			
D6R SII STD CB (FTC) (FRANCE)	BLE	01-05	123/165	17 826 (39,300)	1.88 (6'2") 2.64 (8'8")	3.86 (12'8") 3.2 (10'6")	PS	3.8 (2.4)	6.6 (4.1)	11.5 (7.2)			
D6R SII STD CB (FTC) (JAPAN)	BMK	01-06	123/165	17 826 (39,300)	1.88 (6'2") 2.64 (8'8")	3.86 (12'8") 3.2 (10'6")	PS	3.8 (2.4)	6.6 (4.1)	11.5 (7.2)			
D6R SII STD DS (US)	AFM	01-05	123/165	18 099 (39,900)	1.88 (6'2") 2.64 (8'8")	3.86 (12'8") 3.2 (10'6")	PS	3.8 (2.3)	6.6 (4.1)	11.4 (7.1)			

\*Width without blade and with standard shoes.

\*\*Height with ROPS cab.

NOTE: Power Shift models show speeds only, not drawbar pull.

NOTE: Track-Type Tractor weights do not include blades until 1967.

## Track-Type Tractors (cont'd)

Model	Product Ident. No. Prefix	Years Built	Horse-power FW/ Drawbar	Approx. Machine Weight kg (lb)	Gauge m (ft) and Width m (ft)	Length m (ft) and Height m (ft)	Transmission	Rated Drawbar Pull — kg (lb) and Forward Speed — km/h (mph)					
								1st	2nd	3rd	4th	5th	6th
D6R SII STD DS (BRAZIL)	BPM	03-06	123/165	18 099 (39,900)	1.88 (6'2") 2.64 (8'8")	3.86 (12'8") 3.2 (10'6")	PS	3.8 (2.3)	6.6 (4.1)	11.4 (7.1)			
D6R SII STD DS (FRANCE)	BLT	02-05	123/165	18 099 (39,900)	1.88 (6'2") 2.64 (8'8")	3.86 (12'8") 3.2 (10'6")	PS	3.8 (2.3)	6.6 (4.1)	11.4 (7.1)			
D6R SII STD DS (JAPAN)	BNL	01-06	123/165	18 099 (39,900)	1.88 (6'2") 2.64 (8'8")	3.86 (12'8") 3.2 (10'6")	PS	3.8 (2.3)	6.6 (4.1)	11.4 (7.1)			
D6R SII XL CB (FTC) (US)	AGM	00-05	138/185	18 711 (41,250)	1.88 (6'2") 2.64 (8'8")	3.86 (12'8") 3.2 (10'6")	PS	3.8 (2.4)	6.6 (4.1)	11.5 (7.2)			
D6R SII XL CB (FTC) (BRAZIL)	CAD	02-06	138/185	18 711 (41,250)	1.88 (6'2") 2.64 (8'8")	3.86 (12'8") 3.2 (10'6")	PS	3.8 (2.4)	6.6 (4.1)	11.5 (7.2)			
D6R SII XL CB (FTC) (FRANCE)	BMJ	02-05	138/185	18 711 (41,250)	1.88 (6'2") 2.64 (8'8")	3.86 (12'8") 3.2 (10'6")	PS	3.8 (2.4)	6.6 (4.1)	11.5 (7.2)			
D6R SII XL CB (FTC) (JAPAN)	BPS	01-06	138/185	18 711 (41,250)	1.88 (6'2") 2.64 (8'8")	3.86 (12'8") 3.2 (10'6")	PS	3.8 (2.4)	6.6 (4.1)	11.5 (7.2)			
D6R SII XL DS (US)	AAX	00-05	138/185	18 847 (41,550)	1.88 (6'2") 2.64 (8'8")	3.86 (12'8") 3.2 (10'6")	PS	3.8 (2.3)	6.6 (4.1)	11.4 (7.1)			
D6R SII XL DS (BRAZIL)	FDT	02-06	138/185	18 847 (41,550)	1.88 (6'2") 2.64 (8'8")	3.86 (12'8") 3.2 (10'6")	PS	3.8 (2.3)	6.6 (4.1)	11.4 (7.1)			
D6R SII XL DS (FRANCE)	BMJ	01-05	138/185	18 847 (41,550)	1.88 (6'2") 2.64 (8'8")	3.86 (12'8") 3.2 (10'6")	PS	3.8 (2.3)	6.6 (4.1)	11.4 (7.1)			
D6R SII XL DS (JAPAN)	BRZ	01-06	138/185	18 847 (41,550)	1.88 (6'2") 2.64 (8'8")	3.86 (12'8") 3.2 (10'6")	PS	3.8 (2.3)	6.6 (4.1)	11.4 (7.1)			
D6R SII XW DS (US)	AEP	2001	138/185	19 550 (43,100)	2.03 (6'8") 2.95 (9'8")	3.86 (12'8") 3.2 (10'6")	PS	3.8 (2.3)	6.6 (4.1)	11.4 (7.1)			

NOTE: Power Shift models show speeds only, not drawbar pull.

NOTE: Track-Type Tractor weights do not include blades until 1967.

Track-Type Tractors (cont'd)

Model	Product Ident. No. Prefix	Years Built	Horse-power FW/ Drawbar	Approx. Machine Weight kg (lb)	Gauge m (ft) and Width m (ft)	Length m (ft) and Height m (ft)	Transmission	Rated Drawbar Pull — kg (lb) and Forward Speed — km/h (mph)						
								1st	2nd	3rd	4th	5th	6th	
D6R SII XW DS (FRANCE)	DAE	02-05	138/185	19 550 (43,100)	2.03 (6'8")	3.86 (12'8")	PS	3.8 (2.3)	6.6 (4.1)	11.4 (7.1)				
					2.95 (9'8")	3.2 (10'6")								
D6R SII XW DS (JAPAN)	BRE	01-06	138/185	19 550 (43,100)	2.03 (6'8")	3.86 (12'8")	PS	3.8 (2.3)	6.6 (4.1)	11.4 (7.1)				
					2.95 (9'8")	3.2 (10'6")								
D6R SII LGP CB (FTC) (US)	ACJ	01-05	138/185	20 865 (46,000)	2.23 (7'3")	4.24 (13'11")	PS	3.8 (2.4)	6.6 (4.1)	11.5 (7.2)				
					3.43 (11'3")	3.25 (10'8")								
D6R SII LGP CB (FTC) (JAPAN)	BPP	01-06	138/185	20 865 (46,000)	2.23 (7'3")	4.24 (13'11")	PS	3.8 (2.4)	6.6 (4.1)	11.5 (7.2)				
					3.43 (11'3")	3.25 (10'8")								
D6R SII LGP DS (US)	ADE	00-05	138/185	21 047 (46,400)	2.23 (7'3")	4.24 (13'11")	PS	3.8 (2.3)	6.6 (4.1)	11.4 (7.1)				
					3.43 (11'3")	3.25 (10'8")								
D6R SII LGP DS (FRANCE)	BNC	01-05	138/185	21 047 (46,400)	2.23 (7'3")	4.24 (13'11")	PS	3.8 (2.3)	6.6 (4.1)	11.4 (7.1)				
					3.43 (11'3")	3.25 (10'8")								
D6R SII LGP DS (JAPAN)	BPZ	01-06	138/185	21 047 (46,400)	2.23 (7'3")	4.24 (13'11")	PS	3.8 (2.3)	6.6 (4.1)	11.4 (7.1)				
					3.43 (11'3")	3.25 (10'8")								
D6R SIII (US) (BRAZIL) (FRANCE)	HCD GMT TBC	05-07 06-07 06-07	138/185	18 326 (40,400)	1.88 (6'2")	3.86 (12'8")	PS	3.8 (2.3)	6.6 (4.1)	11.4 (7.1)				
						3.20 (10'6")								
D6R SIII XL (US) (BRAZIL) (FRANCE)	GJB JDL LFM	05-07 05-07 06-07	149/200	20 081 (44,270)	1.88 (6'2")	3.86 (12'8")	PS	3.8 (2.3)	6.6 (4.1)	11.4 (7.1)				
					2.13 (7'0")	3.20 (10'6")								
D6R SIII XL PAT (US) (FRANCE)	HKE RFC	05-07 06-07	149/200	20 081 (44,270)	1.88 (6'2")	3.86 (12'8")	PS	3.8 (2.3)	6.6 (4.1)	11.4 (7.1)				
					2.13 (7'0")	3.20 (10'6")								
D6R SIII XW (US) (BRAZIL)	MRT DPS	05-07 06-07	149/200	20 672 (45,573)	2.03 (6'8")	3.86 (12'8")	PS	3.8 (2.3)	6.6 (4.1)	11.4 (7.1)				
					2.29 (7'6")	3.20 (10'6")								
D6R SIII XW PAT (US) (FRANCE)	HDC MTJ	05-07 05-07	149/200	20 672 (45,573)	2.03 (6'8")	3.86 (12'8")	PS	3.8 (2.3)	6.6 (4.1)	11.4 (7.1)				
					2.29 (7'6")	3.20 (10'6")								

NOTE: Power Shift models show speeds only, not drawbar pull.  
 NOTE: Track-Type Tractor weights do not include blades until 1967.

## Track-Type Tractors (cont'd)

Model	Product Ident. No. Prefix	Years Built	Horse-power FW/ Drawbar	Approx. Machine Weight kg (lb)	Gauge m (ft) and Width m (ft)	Length m (ft) and Height m (ft)	Transmission	Rated Drawbar Pull — kg (lb) and Forward Speed — km/h (mph)					
								1st	2nd	3rd	4th	5th	6th
D6R SIII LGP (US) (FRANCE)	WRG DMK	05-07	149/200	21 716 (47,874)	2.29 (7'6")	4.25 (13'11")	PS	3.8 (2.3)	6.6 (4.1)	11.4 (7.1)			
		06-07			2.29 (7'6")	3.25 (10'8")							
D6R SIII LGP PAT (US) (FRANCE)	WCB DLM	05-07	149/200	21 716 (47,874)	2.29 (7'6")	4.25 (13'11")	PS	3.8 (2.3)	6.6 (4.1)	11.4 (7.1)			
		05-07			2.29 (7'6")	3.25 (10'8")							
D7	3T	54-55	108/90	11 770 (25,925)	1.88 (6'2") 2.64 (8'1")	4.27 (14'0") 2.06 (6'10")	DD						
D7C	17A	55-59	128/102	11 954 (26,355)	1.88 (6'2")	4.26 (14'0")	DD	11 759 (25,900)	8045 (17,720)	4521 (11,960)	3428 (7550)	2397 (5280)	
					2.64 (8'1")	2.06 (6'10")		2.4 (1.5)	3.5 (2.2)	5.2 (3.2)	7.4 (4.6)	9.5 (5.9)	
D7D	17A	59-61	140/112	12 056 (26,555)	1.88 (6'2")	4.26 (14'0")	DD	12 300 (27,100)	8600 (18,900)	5700 (12,550)	3650 (8080)	2600 (5720)	
					2.64 (8'1")	2.06 (6'10")		2.4 (1.5)	3.5 (2.2)	5.2 (3.2)	7.4 (4.6)	9.5 (5.9)	
D7E	47A	61-68	160/128	14 787 (32,590)	1.98 (6'6")	4.47 (14'8")	DD	14 741 (32,500)	10 296 (22,700)	6803 (15,000)	4259 (9390)	3070 (6770)	
					2.56 (8'5")	2.30 (7'7")		2.4 (1.5)	3.5 (2.2)	4.9 (3.1)	7.4 (4.6)	9.4 (5.9)	
D7E	48A	61-66	160/128	14 787 (32,590)	1.98 (6'6")	4.47 (14'8")	PS						
					2.56 (8'5")	2.30 (7'7")		3.3 (2.1)	5.7 (3.6)	9.3 (5.8)			
D7E	47A	66-69	180/144	15 200 (33,500)	1.98 (6'6")	4.47 (14'8")	DD	17 140 (37,750)	11 350 (25,000)	7420 (16,340)	4540 (9990)	3180 (7010)	
					2.56 (8'5")	2.18 (7'2")		2.4 (1.5)	3.5 (2.2)	5.0 (3.1)	7.4 (4.6)	9.5 (5.9)	
D7E	48A	66-69	180	15 500 (34,000)	1.98 (6'6")	4.47 (14'8")	PS						
					2.56 (8'5")	2.18 (7'2")		3.7 (2.3)	6.4 (4.0)	10.1 (6.3)			
D7F	94N	69-74	180	14 700 (32,400)	1.98 (6'6")	4.15 (13'8")	PS						
					2.56 (8'5")	2.26 (7'5")		3.5 (2.2)	6.3 (3.9)	9.5 (5.9)			
D7F	93N	69-74	180	14 700 (32,400)	1.98 (6'6")	4.15 (13'8")	DD	17 100 (37,600)	11 350 (25,000)	7450 (16,400)	4580 (10,000)	3240 (7140)	
					2.56 (8'5")	2.26 (7'5")		2.4 (1.5)	3.5 (2.2)	5.0 (3.4)	7.4 (4.6)	9.5 (5.9)	

NOTE: Power Shift models show speeds only, not drawbar pull.

NOTE: Track-Type Tractor weights do not include blades until 1967.



Track-Type Tractors (cont'd)

Model	Product Ident. No. Prefix	Years Built	Horse-power FW/ Drawbar	Approx. Machine Weight kg (lb)	Gauge m (ft) and Width m (ft)	Length m (ft) and Height m (ft)	Transmission	Rated Drawbar Pull — kg (lb) and Forward Speed — km/h (mph)					
								1st	2nd	3rd	4th	5th	6th
D7G	92V	77-86	200	20 090 <b>(44,300)</b>	1.98 <b>(6'6")</b> 2.62 <b>(8'7")</b>	4.19 <b>(13'9")</b> 3.35 <b>(11'0")</b>	PS	3.7 <b>(2.3)</b>	6.4 <b>(4.0)</b>	10.0 <b>(6.2)</b>			
D7G	91V	77-86	200	20 090 <b>(44,300)</b>	1.98 <b>(6'6")</b> 2.62 <b>(8'7")</b>	4.19 <b>(13'9")</b> 3.35 <b>(11'0")</b>	DD	17 690 <b>(39,010)</b>	11 730 <b>(25,860)</b>	7680 <b>(16,940)</b>	4700 <b>(10,370)</b>	3320 <b>(7320)</b>	
D7G LGP	72W	77-86	200	22 630 <b>(52,100)</b>	2.18 <b>(7'2")</b> 3.3 <b>(10'11")</b>	4.22 <b>(13'9")</b> 3.28 <b>(10'9")</b>	PS	3.7 <b>(2.3)</b>	6.4 <b>(4.0)</b>	10.0 <b>(6.2)</b>			
D7H (CB)	79Z (E. Peoria) 4AB (Sagami)	92-96	171/230	24 778 <b>(54,635)</b>	1.98 <b>(6'6")</b> 3.9 <b>(12'10")</b>	4.74 <b>(15'6")</b> 3.5 <b>(11'6")</b>	PS	3.5 <b>(2.2)</b>	6.2 <b>(3.8)</b>	10.6 <b>(6.6)</b>			
D7H (DS)	5BF (E. Peoria) 2RG (Sagami)	92-96	171/230	25 077 <b>(55,295)</b>	1.98 <b>(6'6")</b> 3.9 <b>(12'10")</b>	4.74 <b>(15'6")</b> 3.5 <b>(11'6")</b>	PS	3.5 <b>(2.2)</b>	6.2 <b>(3.8)</b>	10.6 <b>(6.6)</b>			
D7H LGP (CB)	80Z (E. Peoria) 5WB (Sagami)	92-96	171/230	27 065 <b>(59,678)</b>	2.24 <b>(7'4")</b> 4.50 <b>(14'9")</b>	4.74 <b>(15'6")</b> 3.58 <b>(11'9")</b>	PS	3.5 <b>(2.2)</b>	6.2 <b>(3.8)</b>	10.6 <b>(6.6)</b>			
D7H LGP (DS)	4FG (E. Peoria) 3XG (Sagami)	92-96	171/230	27 065 <b>(59,678)</b>	2.24 <b>(7'4")</b> 4.50 <b>(14'9")</b>	4.74 <b>(15'6")</b> 3.58 <b>(11'9")</b>	PS	3.5 <b>(2.2)</b>	6.2 <b>(3.8)</b>	10.6 <b>(6.6)</b>			
D7H XR (CB)	79Z (E. Peoria) 4AB (Sagami)	92-96	171/230	25 193 <b>(55,551)</b>	1.98 <b>(6'6")</b> 3.9 <b>(12'10")</b>	4.74 <b>(15'6")</b> 3.5 <b>(11'6")</b>	PS	3.5 <b>(2.2)</b>	6.2 <b>(3.8)</b>	10.6 <b>(6.6)</b>			
D7H XR (DS)	5BF (E. Peoria) 2RG (Sagami)	92-96	171/230	25 492 <b>(56,211)</b>	1.98 <b>(6'6")</b> 3.9 <b>(12'10")</b>	4.74 <b>(15'6")</b> 3.5 <b>(11'6")</b>	PS	3.5 <b>(2.2)</b>	6.2 <b>(3.8)</b>	10.6 <b>(6.6)</b>			
D7H	77Z	85-86	215	19 680 <b>(43,380)</b>	1.98 <b>(6'6")</b> 2.54 <b>(8'5")</b>	4.73 <b>(15'6")</b>	DD	16 834 <b>(37,113)</b> 2.7 <b>(1.7)</b>	12 861 <b>(28,353)</b> 3.5 <b>(2.2)</b>	9703 <b>(21,390)</b> 4.5 <b>(2.8)</b>	7436 <b>(16,394)</b> 5.8 <b>(3.6)</b>	5522 <b>(12,173)</b> 7.6 <b>(4.7)</b>	3940 <b>(8686)</b> 10.0 <b>(6.2)</b>
D7H (US)	79Z*	85-90	215/—	23 647 <b>(52,134)</b>	1.981 <b>(6'6")</b> 2.869 <b>(9'5")</b>	4.619 <b>(15'2")</b> 3.421 <b>(11'3")</b>	PS	3.9 <b>(2.4)</b>	6.8 <b>(4.2)</b>	11.9 <b>(7.4)</b>			
D7H (US)	77Z	85-90	215/—	23 570 <b>(51,960)</b>	1.981 <b>(6'6")</b> 2.869 <b>(9'5")</b>	4.619 <b>(15'2")</b> 3.421 <b>(11'3")</b>	DD	16 834 <b>(37,113)</b> 2.7 <b>(1.7)</b>	12 861 <b>(28,353)</b> 3.5 <b>(2.2)</b>	9703 <b>(21,390)</b> 4.6 <b>(2.8)</b>	7436 <b>(16,394)</b> 5.8 <b>(3.6)</b>	5522 <b>(12,173)</b> 7.6 <b>(4.7)</b>	3940 <b>(8686)</b> 10.0 <b>(6.2)</b>
D7H (US)	5BF*	88-90	215/—	24 351 <b>(53,683)</b>	1.981 <b>(6'6")</b> 2.871 <b>(9'5")</b>	4.624 <b>(15'2")</b> 3.429 <b>(11'3")</b>	PS/DS	3.7 <b>(2.3)</b>	6.4 <b>(4.0)</b>	11.1 <b>(6.9)</b>			

\*D7H models prior to Series II. Product identification number prefix still in use for current product.

NOTE: Power Shift models show speeds only, not drawbar pull.

NOTE: Track-Type Tractor weights do not include blades until 1967.

## Track-Type Tractors (cont'd)

Model	Product Ident. No. Prefix	Years Built	Horsepower FW/ Drawbar	Approx. Machine Weight kg (lb)	Gauge m (ft) and Width m (ft)	Length m (ft) and Height m (ft)	Transmission	Rated Drawbar Pull — kg (lb) and Forward Speed — km/h (mph)							
								1st	2nd	3rd	4th	5th	6th		
D7R STD (US)	2HR	95-01	171 (230)	27 413 (60,436)	2.0 (6'6")	6.04 (19'9")	PS/FTC	3.5 (2.3)	6.4 (4.0)	10.8 (6.8)					
D7R STD	3ZR	96-02	171 (230)	27 413 (60,436)	2.0 (6'6")	6.04 (19'9")	PS/FTC	3.5 (2.3)	6.4 (4.0)	10.8 (6.8)					
D7R XR (US)	2EN	95-01	171 (230)	27 776 (61,236)	2.0 (6'6")	6.04 (19'9")	PS/DS	3.5 (2.3)	6.4 (4.0)	10.8 (6.8)					
D7R XR	5MR	97-02	171 (230)	27 776 (61,236)	2.0 (6'6")	6.04 (19'9")	PS/DS	3.5 (2.3)	6.4 (4.0)	10.8 (6.8)					
D7H LGP (US)	80Z*	85-90	215/—	25 237 (55,638)	2.235 (7'4")	4.619 (15'2")	PS								
					3.371 (11'1")	3.503 (11'6")		3.9 (2.4)	6.8 (4.2)	11.9 (7.4)					
D7R LGP	4SR	96-02	179 (240)	29 500 (65,036)	2.24 (7'4")	5.8 (19'0")	PS/FTC	3.5 (2.3)	6.4 (4.0)	10.8 (6.8)					
D7H LGP (US)	4FG*	87-90	230/—	25 894 (57,086)	2.235 (7'4")	4.624 (15'2")	PS/DS								
					3.377 (11'1")	3.505 (11'6")		3.7 (2.3)	6.4 (4.0)	11.1 (6.9)					
D7R LGP (US)	3DN	95-01	179 (240)	30 605 (67,472)	2.24 (7'4")	5.8 (19'0")	PS/DS	3.5 (2.3)	6.4 (4.0)	10.8 (6.8)					
D7R LGP (US)	9HM	95-01	179 (240)	29 500 (65,036)	2.24 (7'4")	5.8 (19'0")	PS/FTC	3.5 (2.3)	6.4 (4.0)	10.8 (6.8)					
D7H (JPN)	4AB*	86-90	215/—	23 647 (52,134)	1.981 (6'6")	4.619 (15'2")	PS								
					2.869 (9'5")	3.421 (11'3")		3.9 (2.4)	6.8 (4.2)	11.9 (7.4)					
D7H (JPN)	2SB*	86-91	215/—	23 570 (51,960)	1.981 (6'6")	4.619 (15'2")	DD	16 834 (37,113)	12 861 (28,353)	9703 (21,390)	7436 (16,394)	5522 (12,173)	3940 (8686)		
					2.869 (9'5")	3.421 (11'3")		2.7 (1.7)	3.5 (2.2)	4.6 (2.8)	5.8 (3.6)	7.6 (4.7)	10.0 (6.2)		
D7H (JPN)	2RG*	88-90	215/—	24 351 (53,683)	1.981 (6'6")	4.624 (15'2")	PS/DS								
					2.871 (9'5")	3.429 (11'3")		3.7 (2.3)	6.4 (4.0)	11.1 (6.9)					
D7R LGP (JPN)	6ER	96-02	179 (240)	30 605 (67,472)	2.24 (7'4")	5.8 (19'0")	PS/DS	3.5 (2.3)	6.4 (4.0)	10.8 (6.8)					
D7H LGP (JPN)	5WB*	86-90	215/—	25 237 (55,638)	2.235 (7'4")	4.619 (15'2")	PS								
					3.371 (11'1")	3.503 (11'6")		3.9 (2.4)	6.8 (4.2)	11.9 (7.4)					
D7H LGP (JPN)	82Z*	86-91	215/—	25 445 (56,096)	2.235 (7'4")	4.619 (15'2")	DD	16 834 (37,113)	12 861 (28,353)	9703 (21,390)	7436 (16,394)	5522 (12,173)	3940 (8686)		
					3.371 (11'1")	3.503 (11'6")		2.7 (1.7)	3.5 (2.2)	4.6 (2.8)	5.8 (3.6)	7.6 (4.7)	10.0 (6.2)		
D7H LGP (JPN)	3XG*	88-90	230/—	25 894 (57,086)	2.235 (7'4")	4.624 (15'2")	PS/DS								
					3.377 (11'1")	3.505 (11'6")		3.7 (2.3)	6.4 (4.0)	11.1 (6.9)					

\*D7H models prior to Series II. Product identification number prefix still in use for current product.

NOTE: Power Shift models show speeds only, not drawbar pull.

NOTE: Track-Type Tractor weights do not include blades until 1967.

Track-Type Tractors (cont'd)

Model	Product Ident. No. Prefix	Years Built	Horse-power FW/ Drawbar	Approx. Machine Weight kg (lb)	Gauge m (ft) and Width m (ft)	Length m (ft) and Height m (ft)	Transmission	Rated Drawbar Pull — kg (lb) and Forward Speed — km/h (mph)						Remarks
								1st	2nd	3rd	4th	5th	6th	
D8	1H	35-41	110/95	14 790 (32,600)	1.98 (6'6") 2.64 (8'8")	4.64 (15'3") 2.28 (7'6")	*	9680 (21,350)	6870 (15,150)	5720 (12,610)	4800 (10,590)	3860 (8520)	2740 (6050)	RD-8 with 192 cm (78") gauge
D8	8R	41-45	131/113	15 490 (34,160)	1.98 (6'6") 2.64 (8'8")	4.64 (15'3") 1.85 (6'1")	**	13 060 (28,800)	9750 (21,500)	7940 (17,500)	6800 (15,000)	5620 (12,400)	3990 (8800)	
D8	2U	45-53	148/130	16 470 (36,310)	1.98 (6'6") 2.64 (8'8")	4.85 (15'10") 2.18 (7'2")	DD	13 560 (29,900)	9840 (21,700)	7120 (15,700)	5400 (11,900)	3900 (8600)		HP increase, DD transmission
D8	13A	53-55	185/150	16 866 (37,150)	1.98 (6'6") 2.64 (8'8")	4.88 (16'1") 2.18 (7'2")	DD	20 358 (44,840)	12 939 (28,500)	8926 (19,660)	6955 (15,320)	4935 (10,870)		
D8D, G	15A	55-57	191/155	16 310 (35,925)	1.98 (6'6") 2.58 (8'6")	5.23 (17'2") 2.23 (7'8")	TC		5.8 (3.6)	8.5 (5.3)	11.9 (7.4)			
D8E, F	14A	55-57	191/155 Belt	17 734 (39,060)	1.98 (6'6") 2.64 (8'8")	4.88 (16'1") 2.26 (7'6")	DD	20 439 (45,020)	16 135 (35,540)	10 964 (24,150)	7373 (16,240)	4953 (10,910)		
D8H	35A	59-61	235	20 924 (46,032)	2.13 (7'0") 2.87 (9'1")	5.20 (17'1") 2.39 (7'10")	TC		5.6 (3.5)	8.2 (5.1)	12.2 (7.6)			
D8H	36A	58-66	235/185	21 400 (47,180)	2.13 (7'0") 2.87 (9'1")	5.20 (17'1") 2.39 (7'10")	DD	19 958 (44,400)	15 648 (34,500)	10 931 (24,100)	8051 (17,750)	5869 (13,000)	3832 (8450)	
D8H	46A	58-74	270	21 863 (48,210)	2.13 (7'0") 2.87 (9'1")	5.20 (17'1") 2.39 (7'10")	PS		3.8 (2.4)	6.7 (4.2)	10.4 (6.5)			
D8K	76V	74-82	300	31 980 (69,300)†	2.13 (7'0") 3.05 (10'0")	5.26 (17'3") 2.44 (8'0")	DD	25 400 (56,000)	18 930 (41,740)	12 990 (28,640)	9370 (20,650)	6610 (14,580)	4090 (9010)	Turbocharged, Sealed and Lubricated Track
D8K	77V	74-82	300	31 430 (70,500)*	2.13 (7'0") 3.05 (10'0")	5.26 (17'3") 2.44 (8'0")	PS		2.7 (1.7)	3.5 (2.2)	4.8 (3.0)	6.3 (3.9)	8.2 (5.1)	
D8L	53Y 7JC 7YB	82-86 84-90 85-92	335	37 305 (82,243)	2.2 (7'3") 2.84 (9'4")	4.95 (16'2") 3.79 (12'5")	PS		3.9 (2.4)	6.8 (4.2)	11.9 (7.4)			Turbocharged, Sealed and Lubricated Track
D8L SA	4FB	84-87	400/325	36 650 (80,820)	2.54 (8'4") 3.11 (10'3")		DD	31 679 (69,840)	23 115 (50,960)	17 196 (37,910)	12 388 (27,310)	9154 (20,180)	6428 (14,170)	

\* Power transmitted through dry tape flywheel clutch to selective type hinge speed gear set.

\*\* Power transmitted through flexible and over center engagement, dry flywheel clutch with metallic friction surfaces. Selective type change speed gear set.

† Approximate operating weight. Includes lubricants, coolant, full fuel tank, hydraulic control, 8S Bulldozer, ROPS canopy and operator.

All other weights listed in this column are shipping weights.

NOTE: Power Shift models show speeds only, not drawbar pull.

NOTE: Track-Type Tractor weights do not include blades until 1967.

## Track-Type Tractors (cont'd)

Model	Product Ident. No. Prefix	Years Built	Horse-power FW/ Drawbar	Approx. Machine Weight kg (lb)	Gauge m (ft) and Width m (ft)	Length m (ft) and Height m (ft)	Transmission	Rated Drawbar Pull — kg (lb) and Forward Speed — km/h (mph)							
								1st	2nd	3rd	4th	5th	6th		
D8N	9TC 5TJ	87-92	285	37 462	2.08	4.95	PS								
		92-95	285	<b>(82,590)</b>	<b>(6'10")</b>	<b>(16'3")</b>		3.05	3.43	3.5	6.2	10.8			
D8R Series II (US)	6YZ	00-04	310	37 830 <b>(83,400)</b>	2.08	6.91	PS								
					<b>(6'10")</b>	<b>(22'8")</b>		3.05	3.51	3.4	6.0	10.6			
D8R Series II (BRAZIL)	AKA	2000	231/310	37 830 <b>(83,400)</b>	2.08	6.91	PS								
					<b>(6'10")</b>	<b>(22'8")</b>		3.05	3.51	3.4	6.0	10.6			
D9D	18A	55-56	286/230	25 772 <b>(56,765)</b>	2.29	5.46	DD	27 631	21 207	15 423	10 706	7658	4958		
					<b>(7'6")</b>	<b>(17'11")</b>		<b>(60,860)</b>	<b>(46,710)</b>	<b>(33,970)</b>	<b>(23,580)</b>	<b>(16,670)</b>	<b>(10,920)</b>		
					3.03	2.67		2.6	3.4	4.7	6.3	8.1	10.9		
D9D	18A	56-59	320/260	26 125 <b>(57,543)</b>	2.29	5.46	DD	28 603	23 835	16 617	12 167	9171	6106		
					<b>(7'6")</b>	<b>(17'11")</b>		<b>(63,000)</b>	<b>(52,500)</b>	<b>(36,600)</b>	<b>(26,800)</b>	<b>(20,200)</b>	<b>(13,450)</b>		
					3.03	2.67		1.6	2.1	2.9	3.9	5.0	6.8		
D9D	19A	55-56	286/230	25 729 <b>(56,670)</b>	2.29	5.46	TC								
					<b>(7'6")</b>	<b>(17'11")</b>		3.03	2.67	6.6	9.0	12.6			
					<b>(10'0")</b>	<b>(8'9")</b>		4.1	5.6	7.8					
D9D	19A	56-59	320/260	26 238 <b>(57,990)</b>	2.29	5.46	TC								
					<b>(7'6")</b>	<b>(17'11")</b>		3.03	2.68	6.6	9.5	13.0			
					<b>(10'0")</b>	<b>(8'9")</b>		4.1	5.9	8.1					
D9E	50A	59-60	335	27 016 <b>(59,506)</b>	2.29	5.50	TC								
					<b>(7'6")</b>	<b>(18'1")</b>		3.03	2.70	6.8	9.7	13.2			
					<b>(10'0")</b>	<b>(8'11")</b>		4.2	6.0	8.2					
D9D	34A	59-61	335	27 167 <b>(59,837)</b>	2.29	5.50	PS								
					<b>(7'6")</b>	<b>(18'1")</b>		3.03	2.70	4.2	7.2	11.2			
					<b>(10'0")</b>	<b>(8'11")</b>		2.6	4.5	7.0					
D9E	49A	59-60	335/268	26 957 <b>(59,375)</b>	2.29	5.50	DD								
					<b>(7'6")</b>	<b>(18'1")</b>		3.03	2.70	2.7	3.5	4.8	6.4	8.2	11.4
					<b>(10'0")</b>	<b>(8'11")</b>		1.7	2.2	3.0	4.0	5.1	7.1		
D9G	66A	61-74	385	31 072 <b>(68,500)</b>	2.29	5.50	PS								
					<b>(7'6")</b>	<b>(18'1")</b>		3.10	2.10	3.9	6.8	10.5			
					<b>(10'0")</b>	<b>(8'7")</b>		2.4	4.2	6.5					
D9R (CB) (US)	ACL	00-04	410	49 147 <b>(108,350)</b>	2.25	6.84	PS								
					<b>(7'5")</b>	<b>(22'5")</b>		3.30	3.99	3.8	6.8	11.9			
					<b>(10'10")</b>	<b>(13'1")</b>		2.4	4.2	7.4					
D9R (DS) (US)	ABK	00-04	410	49 510 <b>(109,150)</b>	2.25	6.84	PS								
					<b>(7'5")</b>	<b>(22'5")</b>		3.30	3.99	3.8	6.8	11.9			
					<b>(10'10")</b>	<b>(13'1")</b>		2.4	4.2	7.4					

NOTE: Power Shift models show speeds only, not drawbar pull.

NOTE: Track-Type Tractor weights do not include blades until 1967.

Track-Type Tractors (cont'd)

Model	Product Ident. No. Prefix	Years Built	Horse-power FW/ Drawbar	Approx. Machine Weight kg (lb)	Gauge m (ft) and Width m (ft)	Length m (ft) and Height m (ft)	Transmission	Rated Drawbar Pull — kg (lb) and Forward Speed — km/h (mph)						Remarks
								1st	2nd	3rd	4th	5th	6th	
S × S D9G	29N	69-74	770	86 200* (190,000)	5.8* (19'0")	8.0◀ (25'0")	PS	3.9 (2.4)	6.8 (4.2)	10.0 (6.2)				L.H. of S × S D9G
	30N				7.3** (24'0")	2.8◀◀ (9'2")					R.H. of S × S D9G			
Dual D9G	90J	69-74	770	79 470* (175,200)	2.3* (7'6")	12.9◀ (42'6")	PS	3.9 (2.4)	6.8 (4.2)	10.5 (6.5)				Front of Dual D9G
	91J				3.3** (10'9")	3.1◀◀ (9'11")					Rear of Dual D9G			
S × S D9H	99V	74-77	820	83 400* (183,900)	5.8* (19'0")	9.0◀ (26'1")	PS	4.0 (2.5)	6.9 (4.3)	10.8 (6.7)				L.H. of S × S D9H
	12U				7.3** (24'0")	2.9◀◀ (9'6")					R.H. of S × S D9H			
Dual D9H	97V	74-80	820	81 100* (178,800)	2.3* (7'6")	12.9◀ (42'6")	PS	4.0 (2.5)	6.9 (4.3)	10.8 (6.7)				Front of Dual D9H
	98V				3.3** (10'9")	3.1◀◀ (9'11")					Rear of Dual D9H			
D9H	90V	74-81	410	32 840 (72,400)	2.3* (7'6")	5.6 (18'5")	PS	4.0 (2.5)	6.9 (4.3)	10.8 (6.7)				Standard Model
					3.0 (9'11")	2.7◀◀ (8'10")								
D9L	14Y	80-87	460	52 055 (114,656)	2.5 (8'2")	5.32 (17'5")	PS							
					3.11 (10'2")	4.41 (14'6")		3.9 (2.4)	7.2 (4.5)	12.4 (7.7)				
D9N	1JD	86-94	370	42 816 (96,196)	2.55 (7'5")	5.17 (16'11.5")	PS	3.9 (2.4)	6.9 (4.3)	12.1 (7.5)				
	6XJ	93-95		2.43 (9'7")	3.91 (12'10")									
D10	84W	78-86	700	88 245 (194,140)	2.9 (9'6")	5.92 (19'8")	PS	3.9 (2.4)	6.8 (4.2)	11.6 (7.2)				Width 2.2 m (7'0") 2.9 m (9'6") gauge 1.9 × 2.7 m (6'4" × 8'10") gauge Width 3.45 m (11'4")
	76X				3.65 (12'0")	4.63◀◀ (15'2")								
D10N	2YD	87-93	520	66 400 (147,405)	2.55 (8'4")	5.89 (18'4")	PS							
	3SK	93-96		3.30 (10'10")	4.45 (14'7")	4.0 (2.5)		7.1 (4.4)	12.5 (7.7)					
D10R	AKT	01-04	580	65 400 (144,200)	2.55 (8'4")	9.16 (30'0")	PS							
				3.74 (12'3")	4.27 (14'0")	4.0 (2.5)		7.1 (4.4)	12.5 (7.7)					
D11N	74Z	86-93	770	95 900 (211,000)	2.90 (9'6")	6.16 (20'3")	PS							
	4HK	93-96		3.65 (12'0")	4.65 (15'3")	3.9 (2.4)		6.8 (4.4)	11.6 (7.2)					
D11R	7PZ	96-07	850	104 600 (230,100)	2.89 (9'6")	5.21 (17'1")	PS							
					3.60 (11'10")	4.57 (15'0")		3.9 (2.4)	6.8 (4.2)	11.8 (7.3)				
D11R CD	AAF	96-07	850	113 000 (248,600)	2.89 (9'6")	5.21 (17'1")	PS							
				3.81 (12'6")	4.57 (15'0")	3.9 (2.4)		6.8 (4.2)	11.8 (7.3)					

\* Gauge of both tractors combined.

\*\* Width to outside of dozer blade.

\* Approximate weight of both machines plus Bulldozer, hydraulic controls, coolant and 5% fuel. (D10, D11N, D11R includes SS ripper)

NOTE: Power Shift models show speeds only, not drawbar pull.

NOTE: Track-Type Tractor weights do not include blades until 1967.

◀ Length including dozer blade.

◀◀ Overall height excluding stack and canopy.

**TRACK-TYPE TRACTORS MANUFACTURED OUTSIDE U.S.A.**

Source	Model	Product Ident. No. Prefix	Years Built	Horsepower Flywheel/ Drawbar	Transmission	Gauge m (ft)
U.K.	D4C	24A	60-64	63/50	DD	1.52 (5'0")
	D4D	88A	64-67	65/52	DD	1.52 (5'0")
	D6C	82A	64-68	120/93	DD	1.88 (6'2")
	D6C	83A	64-68	120/—	PS	1.88 (6'2")
	D6C	46J	71-77	140/—	DD	1.88 (6'2")
	D6C	47J	71-77	140/—	PS	1.88 (6'2")
	D8H	52A	59-61	235/—	PS	2.13 (7'0")
	D8H	22A	59-66	235/185	DD	2.13 (7'0")
	D8H	68A	60-66	235/—	PS	2.13 (7'0")
	D8K	66V	74-82	300/—	PS	2.13 (7'0")
Brazil	D4D	97F	69-78	75/—	DD	1.52 (5'0")
	D4D	74U	71-78	75/—	PS	1.52 (5'0")
	D6C	24U	71-77	120/93	PS	1.88 (6'2")
	D6C	23U	73-77	120/93	DD	1.88 (6'2")
	D6D	74W	77-92	140/—	DD	1.88 (6'2")
	D6D	75W	77-92	140/—	PS	1.88 (6'2")
	D6D	9FK	92-96	140/—	PS	1.88 (6'2")
	D6E	2MJ	92-96	155/—	PS	1.88 (6'2")
	D6D	19B	85-91	140/—	PS	1.88 (6'2")
	D6M XL	5WR	96-02	104/140	PS	1.89 (6'2")
	D6M XL	6LR	96-02	104/140	PS	1.89 (6'2")
	D8L	7JC	84-90	335/—	PS	2.2 (7'3")
	D8L	7YB	85-92	335/—	PS	2.2 (7'3")
	D8N	7TK	93-95	285/—	PS	2.08 (6'10")
	D8R	9EM	95-	305/—		
D8R Series II	AKA	00-04	310	PS	2.08 (6'10")	
D8R Series II	AKA	00-04	310	PS	3.05 (10'0")	
Australia	D4	29A	59-61	63/50	DD	1.12 (3'8")
	D4	30A	59-60	63/50	DD	1.52 (5'0")
	D4C	54A	60-62	63/52	DD	1.12 (3'8")
	D4C	55A	60-62	65/52	DD	1.52 (5'0")
	D4D	85A	63-68	65/52	DD	1.52 (5'0")
	D5	51H	68-68	93/75	DD	1.88 (6'2")
	D5	52H	68-69	93/—	PS	1.88 (6'2")
	D6	31A	58-60	93/75	DD	1.52 (5'0")
	D6	32A	58-60	93/75	DD	1.18 (6'2")
	D6B	56A	60-66	90/73	DD	1.52 (5'0")
	D6B	57A	60-68	90/73	DD	1.88 (6'2")
	D6C	71A	63-68	120/93	DD	1.88 (6'2")
	D6C	73A	63-68	120/—	PS	1.88 (6'2")
	D6C	55J	69-72	125/—	DD	1.88 (6'2")
	D6C	56J	69-72	125/—	PS	1.88 (6'2")
China	D6G Series 2	C6G	06-10	160	PS	1.88 (6'2")
	D7G Series 2	C7G	06-10	200	PS	1.98 (6'6")

## TRACK-TYPE TRACTORS MANUFACTURED OUTSIDE U.S.A. (cont'd)

Source	Model	Product Ident. No. Prefix	Years Built	Horsepower Flywheel/ Drawbar	Transmission	Gauge m (ft)	
France	D4C	69A	61-63	63/50	DD	1.52 (5'0")	
	D4D	86A	63-68	65/52	DD	1.52 (5'0")	
	D4D LGP	18J	66-68	65/52	DD	1.79 (5'10")	
	D4D	58J	67-68	65/—	PS	1.52 (5'0")	
	D4E	68X	78-86	80/—	DD	1.52 (5'0")	
	D4E	69X	78-85	80/—	PS	1.52 (5'0")	
	D4E LGP	71X	78-85	80/—	DD	1.77 (5'10")	
	D4E LGP	72X	78-86	80/—	PS	1.77 (5'10")	
	D5	62J	69-77	105/—	DD	1.88 (6'2")	
	D5	63J	69-77	105/—	PS	1.88 (6'2")	
	D5 LGP	6R	70-77	105/—	PS	2.06 (6'9")	
	D5 LGP	12R	70-77	105/—	DD	2.06 (6'9")	
	D5B	43X	77-85	105/—	DD	1.88 (6'2")	
	D5B	44X	77-86	105/—	PS	1.88 (6'2")	
	D5B LGP	45X	77-86	105/—	DD	2.06 (6'9")	
	D5B LGP	46X	77-86	105/—	PS	2.06 (6'9")	
	D5B	8MB	84-86	105/—	PS	1.52 (5'0")	
	D5H	8RC	85-96	120/—	PS	1.80 (5'11")	
	D5H LGP	1DD	86-96	130/—	PS	2.16 (7'1")	
	D5H XL	8RJ	86-96	130/—	PS	1.89 (6'2")	
	D5H	7NC	85-96	120/—	DD	1.80 (5'11")	
	D5H LGP	9HC	85-96	130/—	DD	2.16 (7'1")	
	D5M XL	4BR	96-02	82/110	PS	1.77 (5'10")	
	D5M XL	6GN	96-02	82/110	PS	1.77 (5'10")	
	D5M LGP	3DR	96-02	82/110	PS	2.00 (6'7")	
	D5M LGP	3CR	96-02	82/110	PS	2.00 (6'7")	
	D6M XL	9ZM	96-02	104/140	PS	1.89 (6'2")	
	D6M XL	3WN	96-02	104/140	PS	1.89 (6'2")	
	D6M LGP	2RN	96-02	104/140	PS	2.16 (7'1")	
	D6M LGP	4JN	96-02	104/140	PS	2.16 (7'1")	
	Scotland	D6D	19X	78-86	140/—	DD	1.88 (6'2")
		D6D	20X	78-86	140/—	PS	1.88 (6'2")
		D6D	0IY	79-87	125/—	PS	1.88 (6'2")
Glasgow	D6H	7PC	86-87	165/—	PS	1.88 (6'2")	
	D6H LGP	8YC	86-87	165/—	PS	2.23 (7'4")	
Japan	D3	79U	73-79	62/—	PS	1.42 (4'8")	
	D3	82U	73-78	62/—	PS	1.42 (4'8")	
	D3 LGP	6N	73-79	62/—	PS	1.65 (5'5")	
	D3 LGP	83U	73-79	62/—	PS	1.65 (5'5")	
	D3B	23Y	79-87	65/—	PS	1.42 (4'8")	
	D3B LGP	24Y	79-87	65/—	PS	1.65 (5'5")	
	D3B	27Y	79-87	65/—	PS	1.42 (4'8")	
	D3B LGP	28Y	79-87	65/—	PS	1.65 (5'5")	
	D3B	3YC	85-87	65/—	DD	1.42 (4'8")	
	D3B LGP	5MC	85-87	65/—	DD	1.65 (5'5")	
	D3C	5KG	87-90	67/—	PS	1.42 (4'7")	
	D3C Series II	7JG/4HJ	90-93	70/—	PS	1.42 (4'7")	
	D3C LGP	1PJ	87-90	67/—	PS	1.65 (5'4")	
	D3C LGP Series II	8GD/5CJ	90-93	70/—	PS	1.65 (5'4")	
	D3G XL	CFC	01-03	70	HYS	1.45 (4'9")	
	D3G XL Tier 2	JMH	03-07	70	HYS	1.45 (4'9")	
	D3G LGP	CFF	01-03	70	HYS	1.68 (5'6")	
	D3G LGP Tier 2	BYR	03-07	70	HYS	1.68 (5'6")	
	D4D LGP	67A	65-68	65/52	DD	1.79 (5'10")	
	D4D	91A	65-68	65/52	DD	1.52 (5'0")	
	D4E	50X	77-86	80/—	DD	1.52 (5'0")	
	D4E	51X	77-86	80/—	PS	1.52 (5'0")	
	D4E LGP	52X	77-86	80/—	DD	1.77 (5'10")	

**TRACK-TYPE TRACTORS MANUFACTURED OUTSIDE U.S.A. (cont'd)**

Source	Model	Product Ident. No. Prefix	Years Built	Horsepower Flywheel/ Drawbar	Transmission	Gauge m (ft)
Japan (cont'd)	D4C	1RJ	87-90	78/—	PS	1.42 (4'7")
	D4C Series II	7KG	90-93	80/—	PS	1.42 (4'7")
	D4C LGP	2CJ	87-90	78/—	PS	1.65 (5'4")
	D4C LGP Series II	98G	90-93	80/—	PS	1.65 (5'4")
	D4G XL	CFN	01-03	80	HYS	1.50 (4'11")
	D4GXL Tier 2	HYD	03-07	80	HYS	1.50 (4'11")
	D4G LGP	FDC	01-03	80	HYS	1.68 (5'6")
	D4G LGP Tier 2	TLX	03-07	80	HYS	1.68 (5'6")
	D4H	8PB	85-96	90/95	PS	1.67 (5'5")
	D4H LGP	9DB	85-96	105/—	PS	2.0 (6'7")
	D4H	2AC	85-92	90/95	DD	1.67 (5'5")
	D4H LGP	3AC	85-90	90/95	DD	2.0 (6'7")
	D4H XL	8PJ	92-96	105/—	PS	1.77 (5'10")
	D4H LGP	9GJ	92-96	105/—	PS	2.0 (6'7")
	D4H LGP	4NK	92-93	105/—	DD	2.0 (6'7")
	D5	37J	67-68	93/75	DD	1.88 (6'2")
	D5 LGP	98A	67-68	93/75	DD	2.06 (6'9")
	D5	67J	68-77	105/—	DD	1.88 (6'2")
	D5	97J	71-76	105/—	PS	1.88 (6'2")
	D5 LGP	68J	68-77	105/—	DD	2.06 (6'9")
	D5B	47X	77-86	105/—	DD	1.88 (6'2")
	D5B	48X	77-86	105/—	PS	1.88 (6'2")
	D5B LGP	49X	77-86	105/—	DD	2.06 (6'9")
	D5C	6PJ	91-93	90/—	PS	1.54 (5'1")
	D5C LGP	3MK	91-93	90/—	PS	1.72 (5'8")
	D5G XL	FDH	01-03	90	HYS	1.55 (5'1")
	D5GXL Tier 2	WGB	03-07	90	HYS	1.55 (5'1")
	D5G LGP	FDW	01-03	90	HYS	1.73 (5'8")
	D5G LGP Tier 2	RKG	03-07	90	HYS	1.73 (5'8")
	D5H	3MD	86-96	120/—	PS	1.80 (5'11")
	D5H LGP	4KD	86-96	130/—	PS	2.16 (7'1")
	D5H	1YD	86-96	120/—	DD	1.80 (5'11")
	D5H LGP	2SD	86-96	130/—	DD	2.16 (7'1")
	D5M XL	4JS	96-	82/110	PS	1.77 (5'10")
	D5M XL	5ES	96-02	82/110	PS	1.77 (5'10")
	D5M LGP	5FS	96-	82/110	PS	2.00 (6'7")
	D5M LGP	6AS	96-02	82/110	PS	2.00 (6'7")
	D5M LGP	7LR	97-02	78/105	DDPS	2.00 (6'7")
	D6B	37H	66-67	93/75	DD	1.88 (6'2")
	D6B LGP	38H	66-67	93/75	DD	2.06 (6'9")
	D6C	41A	66-68	120/93	DD	1.88 (6'2")
	D6C	96A	66-68	120/93	PS	1.88 (6'2")
	D6C	26K	68-77	125/—	DD	1.88 (6'2")
	D6C	69C	68-77	125/—	PS	1.88 (6'2")
	D6C LGP	90B	71-77	140/—	DD	2.11 (6'11")
	D6D LGP LS	6HC	86-96	160/—	DD	1.88 (6'2")
	D6D	31X	86-98	140/—	PS	1.88 (6'2")
D6D	30X	85-96	140/—	DD	1.88 (6'2")	
D6D PTNR	5YB	88-96	160/—	PS	1.88 (6'2")	
D6M XL	2YS	96-	104/140	PS	1.89 (6'2")	
D6M XL	4HS	96-02	104/140	PS	1.89 (6'2")	
D6M LGP	4GS	96-	104/140	PS	2.16 (7'1")	
D6M LGP	5NR	96-02	104/140	PS	2.16 (7'1")	
D7H	25B	85-92	215/—	DD	1.98 (6'6")	
					2.54 (8'5")	
D7H LGP	82Z	85-92	215/—	DD	2.23 (7'4")	
					3.15 (10'4")	





AGRICULTURAL TRACTORS

Model	Product Ident. No. Prefix	Years Built	Horse-power FW/ Drawbar	Approx. Machine Weight kg (lb)	Height m (ft) Gauge	Drawbar Pull kg (lb)* and Forward Speed km/h (mph)							
						1st	2nd	3rd	4th	5th	6th	7th	8th
						Challenger® 35	8DN	94-98	175/150	9838 - 12 133 (21,690 - 26,750)	3.05 (10'0")	8604 (18,968)	8499 (18,737)
Challenger 35	8RD	99-01	175/150	9838 - 12 133 (21,690 - 26,750)	3.05 (10'0")	8604 (18,968)	8499 (18,737)	8314 (18,329)	7851 (17,307)	7161 (15,787)	6694 (14,757)	5949 (13,116)	5147 (11,348)
Challenger 35	ADK	99-01	175/150	9838 - 12 133 (21,690 - 26,750)	3.05 (10'0")	8604 (18,968)	8499 (18,737)	8314 (18,329)	7851 (17,307)	7161 (15,787)	6694 (14,757)	5949 (13,116)	5147 (11,348)
Challenger MT735		01-02	235/185	10 977 - 20 400 (24,200 - 45,000)	3.37 (11'1")	12 680 (27,900)	12 680 (27,900)	12 680 (27,900)	10 890 (23,950)	9130 (20,090)	8105 (17,830)	7187 (15,810)	6388 (14,050)
Challenger 45	1DR	94-98	200/170	9838 - 12 133 (21,690 - 26,750)	3.05 (10'0")	8675 (19,125)	8675 (19,125)	8675 (19,125)	8255 (18,199)	7710 (16,997)	7318 (16,134)	6757 (14,897)	5891 (12,987)
Challenger 45	ABF	99-01	200/170	9838 - 12 133 (21,690 - 26,750)	3.05 (10'0")	8675 (19,125)	8675 (19,125)	8675 (19,125)	8255 (18,199)	7710 (16,997)	7318 (16,134)	6757 (14,897)	5891 (12,987)
Challenger 45	3BK	99-01	200/170	9838 - 12 133 (21,690 - 26,750)	3.05 (10'0")	8675 (19,125)	8675 (19,125)	8675 (19,125)	8255 (18,199)	7710 (16,997)	7318 (16,134)	6757 (14,897)	5891 (12,987)
Challenger MT745		01-02	255/205	10 977 - 20 400 (24,200 - 45,000)	3.37 (11'1")	12 680 (27,900)	12 680 (27,900)	12 680 (27,900)	11 828 (26,020)	9920 (21,820)	8806 (19,370)	7808 (17,180)	6941 (15,270)
Challenger 55	7DM	96-98	225/191	9838 - 12 133 (21,690 - 26,750)	3.05 (10'0")	8675 (19,125)	8675 (19,125)	8675 (19,125)	8675 (19,125)	8255 (18,200)	7802 (17,200)	7188 (15,848)	6593 (14,535)
Challenger 55	AEN	99-01	225/191	9838 - 12 133 (21,690 - 26,750)	3.05 (10'0")	8675 (19,125)	8675 (19,125)	8675 (19,125)	8675 (19,125)	8255 (18,200)	7802 (17,200)	7188 (15,848)	6593 (14,535)
Challenger 55	6NN	99-01	225/191	9838 - 12 133 (21,690 - 26,750)	3.05 (10'0")	8675 (19,125)	8675 (19,125)	8675 (19,125)	8675 (19,125)	8255 (18,200)	7802 (17,200)	7188 (15,848)	6593 (14,535)
Challenger MT755		01-02	290/235	10 097 - 20 400 (24,200 - 45,000)	3.37 (11'1")	12 682 (27,900)	12 682 (27,900)	12 682 (27,900)	12 682 (27,900)	11 302 (24,865)	10 032 (22,070)	8896 (19,570)	7908 (17,397)
Challenger MT765		01-02	306/255	10 977 - 20 411 (24,200 - 45,000)	3.37 (11'1")	12 682 (27,900)	12 682 (27,900)	12 682 (27,900)	12 682 (27,900)	11 894 (26,168)	10 558 (23,228)	9362 (20,597)	8322 (18,308)

\*Base gauge (no spacers) of 1.47 m (60") available on 8DN1-849, 1DR1-1699, 7DM1-849. Base gauges (no spacers) of 1.47 m (60") and 2.03 m (80") available on 8DN850-Up, 1DR1700-Up, and 7DM850-Up.

## Agricultural Tractors (cont'd)

Model	Product Ident. No. Prefix	Years Built	Horse-power FW/ Drawbar	Approx. Machine Weight kg (lb)	Height m (ft) Gauge m (ft)	Drawbar Pull kg (lb)* and Forward Speed km/h (mph)							
						9th	10th	11th	12th	13th	14th	15th	16th
						Challenger 35	8DN	94-98	175/150	9838 - 12 133 (21,690 - 26,750)	3.05 (10'0")	4436 (9779)	3740 (8244)
				1.47* (60")*	9.39 (5.8)	11.11 (6.9)	12.70 (7.9)	15.04 (9.3)	17.60 (10.9)	20.70 (12.9)	24.49 (15.2)	28.64 (17.8)	
Challenger 35	8RD	99-01	175/150	9838 - 12 133 (21,690 - 26,750)	3.05 (10'0")	4436 (9779)	3740 (8244)	3171 (6991)	2601 (5735)	2154 (4749)	1771 (3904)	1449 (3194)	1196 (2637)
				1.47 (60")	9.39 (5.8)	11.11 (6.9)	12.70 (7.9)	15.04 (9.3)	17.60 (10.9)	20.70 (12.9)	24.49 (15.2)	28.64 (17.8)	
Challenger 35	ADK	99-01	175/150	9838 - 12 133 (21,690 - 26,750)	3.05 (10'0")	4436 (9779)	3740 (8244)	3171 (6991)	2601 (5735)	2154 (4749)	1771 (3904)	1449 (3194)	1196 (2637)
				2.03 (80")	9.39 (5.8)	11.11 (6.9)	12.70 (7.9)	15.04 (9.3)	17.60 (10.9)	20.70 (12.9)	24.49 (15.2)	28.64 (17.8)	
Challenger MT735		01-02	235/185	10 977 - 20 400 (24,200 - 45,000)	3.37 (11'1")	5678 (12,490)	5047 (11,100)	4476 (9850)	3974 (8742)	3339 (7346)	2628 (5782)	2077 (4568)	1635 (3598)
						10.4 (6.5)	11.7 (7.3)	13.2 (8.2)	14.9 (9.3)	17.7 (11.0)	22.5 (14.0)	28.5 (17.7)	39.7 (24.6)
Challenger 45	1DR	94-98	200/170	9838 - 12 133 (21,690 - 26,750)	3.05 (10'0")	5063 (11,162)	4170 (9193)	3547 (7821)	2920 (6438)	2427 (5351)	2003 (4416)	1646 (3629)	1365 (3010)
				1.47* (60")*	9.39 (5.8)	11.11 (6.9)	12.70 (7.9)	15.04 (9.3)	17.60 (10.9)	20.70 (12.9)	24.49 (15.2)	28.64 (17.8)	
Challenger 45	ABF	99-01	200/170	9838 - 12 133 (21,690 - 26,750)	3.05 (10'0")	5063 (11,162)	4170 (9193)	3547 (7821)	2920 (6438)	2427 (5351)	2003 (4416)	1646 (3629)	1365 (3010)
				1.47 (60")	9.39 (5.8)	11.11 (6.9)	12.70 (7.9)	15.04 (9.3)	17.60 (10.9)	20.70 (12.9)	24.49 (15.2)	28.64 (17.8)	
Challenger 45	3BK	99-01	200/170	9838 - 12 133 (21,690 - 26,750)	3.05 (10'0")	5063 (11,162)	4170 (9193)	3547 (7821)	2920 (6438)	2427 (5351)	2003 (4416)	1646 (3629)	1365 (3010)
				2.03 (80")	9.39 (5.8)	11.11 (6.9)	12.70 (7.9)	15.04 (9.3)	17.60 (10.9)	20.70 (12.9)	24.49 (15.2)	28.64 (17.8)	
Challenger MT745		01-02	255/205	10 977 - 20 400 (24,200 - 45,000)	3.37 (11'1")	6169 (13,573)	5484 (12,065)	4864 (10,700)	4317 (9498)	3628 (7981)	2856 (6282)	2256 (4963)	1777 (3909)
						10.4 (6.5)	11.7 (7.3)	13.2 (8.2)	14.9 (9.3)	17.7 (11.0)	22.5 (14.0)	28.5 (17.7)	39.7 (24.6)
Challenger 55	7DM	96-98	225/191	9838 - 12 133 (21,690 - 26,750)	3.05 (10'0")	5663 (12,484)	4676 (10,310)	3990 (8796)	3295 (7264)	2747 (6056)	2275 (5015)	1876 (4135)	1562 (3443)
				1.47* (60")*	9.39 (5.8)	11.11 (6.9)	12.70 (7.9)	15.04 (9.3)	17.60 (10.9)	20.70 (12.9)	24.49 (15.2)	28.64 (17.8)	
Challenger 55	AEN	99-01	225/191	9838 - 12 133 (21,690 - 26,750)	3.05 (10'0")	5663 (12,484)	4676 (10,310)	3990 (8796)	3295 (7264)	2747 (6056)	2275 (5015)	1876 (4135)	1562 (3443)
				2.03 (80")	9.39 (5.8)	11.11 (6.9)	12.70 (7.9)	15.04 (9.3)	17.60 (10.9)	20.70 (12.9)	24.49 (15.2)	28.64 (17.8)	
Challenger 55	6NN	99-01	225/191	9838 - 12 133 (21,690 - 26,750)	3.05 (10'0")	5663 (12,484)	4676 (10,310)	3990 (8796)	3295 (7264)	2747 (6056)	2275 (5015)	1876 (4135)	1562 (3443)
				1.47 (60")	9.39 (5.8)	11.11 (6.9)	12.70 (7.9)	15.04 (9.3)	17.60 (10.9)	20.70 (12.9)	24.49 (15.2)	28.64 (17.8)	
Challenger MT755		01-02	290/235	10 097 - 20 400 (24,200 - 45,000)	3.37 (11'1")	7029 (15,464)	6248 (13,745)	5541 (12,190)	4919 (10,821)	4133 (9093)	3253 (7157)	2570 (5655)	2024 (4454)
						10.4 (6.5)	11.7 (7.3)	13.2 (8.2)	14.9 (9.3)	17.7 (11.0)	22.5 (14.0)	28.5 (17.7)	39.7 (24.6)
Challenger MT765		01-02	306/255	10 977 - 20 411 (24,200 - 45,000)	3.37 (11'1")	7397 (16,274)	6575 (14,466)	5831 (12,829)	5176 (11,388)	4350 (9569)	3424 (7533)	2705 (5951)	2130 (4687)
						10.4 (6.5)	11.7 (7.3)	13.2 (8.2)	14.9 (9.3)	17.7 (11.0)	22.5 (14.0)	28.5 (17.7)	39.7 (24.6)

\*Base gauge (no spacers) of 1.47 m (60") available on 8DN1-849, 1DR1-1699, 7DM1-849. Base gauges (no spacers) of 1.47 m (60") and 2.03 m (80") available on 8DN850-Up, 1DR1700-Up, and 7DM850-Up.

**Agricultural Tractors (cont'd)**

Model	Product Ident. No. Prefix	Years Built	Horse-power FW/ Drawbar	Approx. Machine Weight kg (lb)	Height m (ft) Gauge m (ft)	Drawbar Pull kg (lb)* and Forward Speed km/h (mph)									
						1st	2nd	3rd	4th	5th	6th	7th	8th	9th	10th
Challenger 65	7YC	86-90	270/200	14 061 (31,000)	3.24 (10'8")	14 825	10 393	8880	7701	6656	5708	4950	4245	2858	1725
						<b>(32,684)</b>	<b>(22,912)</b>	<b>(19,577)</b>	<b>(16,978)</b>	<b>(14,674)</b>	<b>(12,583)</b>	<b>(10,912)</b>	<b>(9358)</b>	<b>(6300)</b>	<b>(3803)</b>
						2.15 (7'1")	4.2 (2.6)	6.4 (4.0)	7.5 (4.7)	8.6 (5.3)	9.9 (6.1)	11.3 (7.0)	13.0 (8.1)	14.9 (9.3)	19.3 (12.0)
Challenger 65B	7YC	91-92	285/225	14 060 (31,000)	3.24 (10'8")	14 893	11 074	9492	8252	7138	6109	5294	4545	3057	1851
						<b>(32,914)</b>	<b>(24,413)</b>	<b>(20,926)</b>	<b>(18,193)</b>	<b>(15,737)</b>	<b>(13,467)</b>	<b>(11,672)</b>	<b>(10,019)</b>	<b>(6740)</b>	<b>(4080)</b>
						2.15 (7'1")	4.2 (2.6)	6.4 (4.0)	7.5 (4.7)	8.6 (5.3)	9.9 (6.1)	11.3 (7.0)	13.0 (8.1)	14.9 (9.3)	19.3 (12.0)
Challenger 65C	2ZJ	93-95	285/225	14 330 (31,530)	3.24 (10'8")	12 587	9574	8186	7156	6147	5230	4497	3855	2701	1637
						<b>(27,750)</b>	<b>(21,106)</b>	<b>(18,046)</b>	<b>(15,775)</b>	<b>(13,551)</b>	<b>(11,530)</b>	<b>(9914)</b>	<b>(8498)</b>	<b>(5955)</b>	<b>(3610)</b>
						2.29 (7'5")	4.2 (2.6)	6.4 (4.0)	7.5 (4.7)	8.6 (5.3)	9.9 (6.1)	11.3 (7.0)	13.0 (8.1)	14.9 (9.3)	19.3 (12.0)
Challenger 65D	2ZJ	95-97	300	14 909 (32,875)	3.24 (10'8")	12 689	10 706	9161	7934	6837	5843	5005	4256	3119	2030
						<b>(27,975)</b>	<b>(23,603)</b>	<b>(20,197)</b>	<b>(17,492)</b>	<b>(15,072)</b>	<b>(12,881)</b>	<b>(11,034)</b>	<b>(9382)</b>	<b>(6875)</b>	<b>(4475)</b>
						2.29 (7'5")	4.2 (2.6)	6.4 (4.0)	7.5 (4.7)	8.6 (5.3)	9.9 (6.1)	11.3 (7.0)	13.0 (8.1)	14.9 (9.3)	19.3 (12.0)
Challenger 65E	97-02	310/277	15 186 (33,480)	3.4 (11'2")	15 098	10 808	9265	8096	6964	6017	5247	4469	3396	2279	
					<b>(33,284)</b>	<b>(23,827)</b>	<b>(20,425)</b>	<b>(17,849)</b>	<b>(15,352)</b>	<b>(13,265)</b>	<b>(11,567)</b>	<b>(9853)</b>	<b>(7488)</b>	<b>(5025)</b>	
					4.3 (2.7)	6.4 (4.0)	7.6 (4.7)	8.7 (5.4)	10.0 (6.2)	11.3 (7.0)	12.9 (8.0)	14.8 (9.2)	19.3 (12.0)	29.0 (18.0)	
Challenger 70C	2YL	93-95	1st Gear 215/154 2nd & up 285/225	16 201 (35,685)	3.24 (10'8")	12 621	9574	8186	7156	6147	5230	4497	3855	2701	1637
						<b>(27,825)</b>	<b>(21,106)</b>	<b>(18,046)</b>	<b>(15,775)</b>	<b>(13,551)</b>	<b>(11,530)</b>	<b>(9914)</b>	<b>(8498)</b>	<b>(5955)</b>	<b>(3610)</b>
						2.29 (7'5")	4.2 (2.6)	6.4 (4.0)	7.5 (4.7)	8.6 (5.3)	9.9 (6.1)	11.3 (7.0)	13.0 (8.1)	14.9 (9.3)	19.3 (12.0)
Challenger 75	4CJ	91-92	325/256	14 060 (31,000)	3.24 (10'8")	15 391	12 371	10 753	9382	8073	6923	6017	5162	3588	2181
						<b>(33,931)</b>	<b>(27,273)</b>	<b>(23,706)</b>	<b>(20,684)</b>	<b>(17,797)</b>	<b>(15,263)</b>	<b>(13,264)</b>	<b>(11,379)</b>	<b>(7910)</b>	<b>(4830)</b>
						2.15 (7'1")	4.2 (2.6)	6.4 (4.0)	7.5 (4.7)	8.6 (5.3)	9.9 (6.1)	11.3 (7.0)	13.0 (8.1)	14.9 (9.3)	19.3 (12.0)
Challenger 75C	4KK	92-97	325/268	15 158 (33,419)	3.24 (10'8")	12 689	10 761	9329	8106	6932	5944	5095	4380	3075	1878
						<b>(27,975)</b>	<b>(23,724)</b>	<b>(20,567)</b>	<b>(17,871)</b>	<b>(15,282)</b>	<b>(13,105)</b>	<b>(11,232)</b>	<b>(9657)</b>	<b>(6780)</b>	<b>(4140)</b>
						2.29 (7'5")	4.2 (2.6)	6.4 (4.0)	7.5 (4.7)	8.6 (5.3)	9.9 (6.1)	11.3 (7.0)	13.0 (8.1)	14.9 (9.3)	19.3 (12.0)
Challenger 75D	5AR	96-97	330	14 878 (32,800)	3.24 (10'8")	12 884	12 562	10 919	9526	8197	7030	6109	5241	3643	2225
						<b>(28,406)</b>	<b>(27,693)</b>	<b>(24,071)</b>	<b>(21,003)</b>	<b>(18,071)</b>	<b>(15,498)</b>	<b>(13,468)</b>	<b>(11,554)</b>	<b>(8031)</b>	<b>(4904)</b>
						2.29 (7'5")	4.2 (2.6)	6.4 (4.0)	7.5 (4.7)	8.6 (5.3)	9.9 (6.1)	11.3 (7.0)	13.0 (8.1)	14.9 (9.3)	19.3 (12.0)
Challenger 75E	97-02	340/301	15 186 (33,480)	3.4 (11'2")	15 174	11 696	9402	8155	7015	6412	5543	4798	3502	2447	
					<b>(33,452)</b>	<b>(25,785)</b>	<b>(20,728)</b>	<b>(17,979)</b>	<b>(15,466)</b>	<b>(14,135)</b>	<b>(12,221)</b>	<b>(10,578)</b>	<b>(7722)</b>	<b>(5395)</b>	
					2.29 (7'6")	4.5 (2.8)	6.4 (4.0)	7.9 (4.9)	9.0 (5.6)	10.3 (6.4)	11.3 (7.0)	12.9 (8.0)	14.8 (9.2)	20.1 (12.5)	29.0 (18.0)
Challenger 85C	9TK	92-97	1-2 Gears 325/216 3-10 Gears 355/272	15 286 (33,700)	3.24 (10'8")	12 689	11 596	9544	8302	7089	6406	5490	4720	3146	2024
						<b>(27,975)</b>	<b>(25,565)</b>	<b>(21,042)</b>	<b>(18,304)</b>	<b>(15,629)</b>	<b>(14,122)</b>	<b>(12,104)</b>	<b>(10,406)</b>	<b>(6935)</b>	<b>(4461)</b>
						2.29 (7'5")	4.5 (2.8)	6.4 (4.0)	7.9 (4.9)	9.0 (5.6)	10.5 (6.5)	11.3 (7.0)	13.0 (8.1)	14.9 (9.3)	20.3 (12.6)
Challenger 85D	4GR	96-97	Gears 1-2 330 3-5 360 6-10 370	15 286 (33,700)	3.24 (10'8")	15 529	10 684	9599	8247	7175	6590	5705	4887	3825	2461
						<b>(34,234)</b>	<b>(23,520)</b>	<b>(21,162)</b>	<b>(18,181)</b>	<b>(15,819)</b>	<b>(14,528)</b>	<b>(12,578)</b>	<b>(10,774)</b>	<b>(8432)</b>	<b>(5425)</b>
						2.29 (7'5")	4.0 (2.5)	6.25 (3.9)	7.75 (4.8)	8.9 (5.5)	10.2 (6.4)	11.2 (7.0)	12.8 (8.0)	14.7 (9.2)	20.3 (12.6)
Challenger 85E	97-02	375/339	15 413 (33,980)	3.4 (11'2")	15 454	11 576	10 566	9177	7997	7268	6323	5417	3954	2763	
					<b>(34,070)</b>	<b>(25,520)</b>	<b>(23,294)</b>	<b>(20,232)</b>	<b>(17,629)</b>	<b>(16,022)</b>	<b>(13,940)</b>	<b>(11,942)</b>	<b>(8718)</b>	<b>(6090)</b>	
					2.29 (7'6")	4.5 (2.8)	6.4 (4.0)	7.9 (4.9)	9.0 (5.6)	10.3 (6.4)	11.3 (7.0)	12.9 (8.0)	14.8 (9.2)	20.1 (12.5)	29.0 (18.0)

\*Drawbar pull figures for SA and SR models are max. at lug.

NOTE: Drawbar pull figures for the Challenger 65 is at max. power as found in University of Nebraska Tractor Test no. 1268.

This test was performed on concrete. Therefore, usable drawbar pull may be less depending upon soil conditions.

## Agricultural Tractors (cont'd)

Model	Product Ident. No. Prefix	Years Built	Horse-power FW/ Drawbar	Approx. Machine Weight kg (lb)	Height m (ft) Gauge m (ft)	Drawbar Pull kg (lb)* and Forward Speed km/h (mph)									
						1st	2nd	3rd	4th	5th	6th	7th	8th	9th	10th
						Challenger 95E	97-02	410/375	15 413 (33,980)	3.4 (11'2") 2.29 (7'6")	15 968 (35,202)	11 506 (25,366)	10 505 (23,159)	10 085 (22,234)	8729 (19,244)
D3B SA	2PC	85-87	101 (14,670)	2.71 (8'11")	7634 (16,830)	6226 (13,725)	5306 (11,700)	4531 (9990)	3888 (8573)						
D3C SA	7JF	87-92	101 (15,846)	2.71 (8'11") 1.52 (5'0")	5552 (12,250)	4521 (9960)	3827 (8450)	3235 (7130)	2755 (6070)						
D4D SA	20J	66-68	—/68 (14,900)	2.44 (8'0") 1.52 (5'0")	4590 (10,120)	3928 (8660)	3098 (6830)	2631 (5800)	2232 (4920)						
D4D SA	84J	66	—/68 (14,270)	2.67 (8'9") 1.52 (5'0")	4880 (10,750)	4170 (9200)	3310 (7300)	2840 (6260)	2420 (5330)						
D4E SA	7PB 2CB	84-89 84-91	97 (16,760)	2.71 (8'11")	5901 (13,102)	5148 (11,349)	5831 (12,859)	5002 (11,027)	4433 (9773)						
D4E SA	29X	77-84	—/74 (16,722)	2.72 (8'11") 1.52 (5'0")	5802 (12,791)	4986 (10,993)	4007 (8835)	3814 (8408)	2896 (6384)						
D4E SR		84-99	125/— (20,730)	1.93 (6'4") 1.52 (5'0")	5450 (12,010)	3744 (8250)	5068 (11,170)	4408 (9715)	3832 (8450)						
D5 SA	21J	67-67	—/90 (20,400)	2.64 (8'8") 1.88 (6'2")	6620 (14,580)	5160 (11,360)	3990 (8740)	3080 (6790)	2290 (5030)						
D5 SA	98J	67-77	—/90 (21,300)	2.95 (9'8") 1.88 (6'2")	6120 (13,500)	5180 (11,410)	4110 (9950)	3640 (7620)	2950 (6500)	2250 (4970)					
D5B SA	26X	77-84	—/90	2.77 (9'1") 1.88 (6'2")	6409 (14,130)	5384 (11,870)	4323 (9530)	3688 (8130)	3180 (7010)	2486 (5480)					
D5B SA	22X	77-82	105/— (24,875)	2.77 (9'1") 1.52 (5'0")	8060 (17,770)	5030 (11,100)	3410 (7520)	2290 (5060)	1480 (3260)						
D5B SA	24X	77-84	105/— (25,615)	2.77 (9'1") 1.52 (5'0")											
					3.5 (2.2)	6.1 (3.8)	10.1 (6.3)								

\*Drawbar pull figures for SA and SR models are max. at lug.

NOTE: Drawbar pull figures for the Challenger 65 is at max. power as found in University of Nebraska Tractor Test no. 1268.

This test was performed on concrete. Therefore, usable drawbar pull may be less depending upon soil conditions.

**Agricultural Tractors (cont'd)**

Model	Product Ident. No. Prefix	Years Built	Horse-power FW/ Drawbar	Approx. Machine Weight kg (lb)	Height m (ft) Gauge m (ft)	Drawbar Pull kg (lb)* and Forward Speed km/h (mph)											
						1st	2nd	3rd	4th	5th	6th	7th	8th	9th	10th		
D6C SA	17R	70-76	140	13 064 <b>(28,800)</b>	2.67 <b>(8'9")</b>	850 <b>(18,750)</b>	6970 <b>(15,370)</b>	5880 <b>(12,780)</b>	4810 <b>(10,610)</b>	4080 <b>(9000)</b>	3190 <b>(7030)</b>						
						4.0 <b>(2.5)</b>	4.8 <b>(3.0)</b>	5.6 <b>(3.5)</b>	6.4 <b>(4.0)</b>	7.4 <b>(4.6)</b>	8.8 <b>(5.5)</b>						
D6D SR	7XF	89-91	140	15 200 <b>(33,500)</b>	2.87 <b>(9'5")</b>	14 358 <b>(31,645)</b>	12 429 <b>(27,394)</b>	11 721 <b>(25,833)</b>	7067 <b>(15,576)</b>	6096 <b>(13,436)</b>	4931 <b>(10,868)</b>						
						2.0 <b>(1.2)</b>	2.9 <b>(1.8)</b>	4.1 <b>(2.5)</b>	6.5 <b>(4.0)</b>	7.4 <b>(4.6)</b>	8.9 <b>(5.5)</b>						
D6D SA 123-161 kW (165-215 HP)	38C	83-91	165	14 500 <b>(32,000)</b>	2.87 <b>(9'5")</b>	10 098 <b>(22,243)</b>	8510 <b>(18,744)</b>	9210 <b>(20,287)</b>	7789 <b>(17,156)</b>	6732 <b>(14,828)</b>	5456 <b>(12,017)</b>						
						4.5 <b>(2.8)</b>	5.3 <b>(3.3)</b>	6.1 <b>(3.8)</b>	7.1 <b>(4.4)</b>	8.2 <b>(5.1)</b>	9.8 <b>(6.1)</b>						
D6D SA 123-179 kW (165-240 HP)	19B	83-91	165	14 500 <b>(32,000)</b>	2.87 <b>(9'5")</b>	10 098 <b>(22,243)</b>	8510 <b>(18,744)</b>	7181 <b>(15,817)</b>	8732 <b>(19,234)</b>	7560 <b>(16,651)</b>	6144 <b>(13,532)</b>						
						4.5 <b>(2.8)</b>	5.3 <b>(3.3)</b>	6.1 <b>(3.8)</b>	7.1 <b>(4.4)</b>	8.2 <b>(5.1)</b>	9.8 <b>(6.1)</b>						
D6E SR	8FJ	91-96	155/216 121/170	14 960 <b>(32,987)</b>	2.03 <b>(6'8")</b> 1.88 <b>(6'2")</b>	11 308 <b>(24,878)</b>	7771 <b>(17,097)</b>	8130 <b>(17,887)</b>	6866 <b>(15,105)</b>	5926 <b>(13,037)</b>	3135 <b>(6987)</b>						
						3.0 <b>(1.9)</b>	4.3 <b>(2.7)</b>	5.8 <b>(2.6)</b>	6.8 <b>(4.3)</b>	7.7 <b>(4.8)</b>	9.3 <b>(5.8)</b>						
Ag 6 Generation One	05X	77-86	165/240	14 787 <b>(32,600)</b>	3.43 <b>(11'3")</b>	10 034 <b>(22,120)</b>	8455 <b>(18,639)</b>	7134 <b>(15,727)</b>	9041 <b>(19,931)</b>	7830 <b>(17,268)</b>							
						4.5 <b>(2.8)</b>	5.3 <b>(3.3)</b>	6.1 <b>(3.8)</b>	7.1 <b>(4.4)</b>	8.2 <b>(5.1)</b>							
Ag 6 Generation Two	05X	77-86	200/240	14 787 <b>(32,600)</b>	3.48 <b>(11'5")</b>	12 407 <b>(27,353)</b>	10 482 <b>(23,110)</b>	10 667 <b>(23,514)</b>	9091 <b>(19,931)</b>	7830 <b>(17,263)</b>							
						4.5 <b>(2.8)</b>	5.3 <b>(3.3)</b>	6.1 <b>(3.8)</b>	7.1 <b>(4.4)</b>	8.2 <b>(5.1)</b>							
D7G SA std. trans.	35N	80-86	250	18 462 <b>(40,700)</b>	3.2 <b>(10'6")</b>	19 101 <b>(42,110)</b>	13 622 <b>(30,030)</b>	11 358 <b>(25,040)</b>	10 015 <b>(22,080)</b>	8627 <b>(19,020)</b>	7584 <b>(16,720)</b>						
						3.5 <b>(2.2)</b>	4.8 <b>(3.0)</b>	5.6 <b>(3.5)</b>	6.4 <b>(4.0)</b>	7.2 <b>(4.5)</b>	8.2 <b>(5.1)</b>						
D7G SA std. trans. 168-186 kW (225-250 HP)		77-86	250	18 462 <b>(40,700)</b>	3.2 <b>(10'6")</b>	16 990 <b>(37,424)</b>	12 090 <b>(26,631)</b>	11 358 <b>(25,040)</b>	10 015 <b>(22,080)</b>	8627 <b>(19,020)</b>	7584 <b>(16,720)</b>						
						3.5 <b>(2.2)</b>	4.8 <b>(3.0)</b>	5.6 <b>(3.5)</b>	6.4 <b>(4.0)</b>	7.2 <b>(4.5)</b>	8.2 <b>(5.1)</b>						
D8L SA		84-87	400	36 650 <b>(80,820)</b>	3.87 <b>(12'8")</b> 2.2 <b>(7'3")</b>	40 252 <b>(88,740)</b>	39 466 <b>(64,960)</b>	22 013 <b>(48,530)</b>	15 953 <b>(35,170)</b>	11 880 <b>(26,190)</b>	8446 <b>(18,620)</b>						
						2.9 <b>(1.8)</b>	3.9 <b>(2.4)</b>	5.0 <b>(3.1)</b>	6.8 <b>(4.2)</b>	8.9 <b>(5.5)</b>	11.9 <b>(7.4)</b>						

\*Drawbar pull figures for SA and SR models are max. at lug.

**NOTE:** Drawbar pull figures for the Challenger 65 is at max. power as found in University of Nebraska Tractor Test no. 1268.

This test was performed on concrete. Therefore, usable drawbar pull may be less depending upon soil conditions.



## MOTOR GRADERS

Model	Product Ident. No. Prefix	Years Built	Horsepower, Rated	Approx. Ship Wt. kg (lb)	Wheel-base m (ft)	Length m (ft)	Width m (ft)	Mold-board Length m (ft)	Turning Radius m (ft)	Controls	Maximum Speed km/h (mph)	
											Forward	Rev.
212TD	79C	54-57	50	6030 <b>(13,290)</b>	5.03 <b>(16'6")</b>	6.68 <b>(21'11")</b>	2.07 <b>(6'10")</b>	3.05 <b>(10'0")</b>	11.10 <b>(36'5")</b>	Mech.	18.1 <b>(11.2)</b>	4.2 <b>(2.6)</b>
112	3U	47-59	70	8770 <b>(19,330)</b>	5.72 <b>(18'9")</b>	7.59 <b>(24'11")</b>	2.39 <b>(7'10")</b>	3.66 <b>(12'0")</b>	10.87 <b>(35'8")</b>	Mech.	25.7 <b>(16.0)</b>	6.4 <b>(4.0)</b>
112	81C	55-59	75	9435 <b>(20,805)</b>	5.72 <b>(18'9")</b>	7.59 <b>(24'11")</b>	2.39 <b>(7'10")</b>	3.66 <b>(12'0")</b>	10.74 <b>(35'3")</b>	Mech.	25.7 <b>(16.0)</b>	6.4 <b>(4.0)</b>
112E	68E(U.S.) 91G(U.S.)	59-64 64-68	85	9500 <b>(20,900)</b>	5.72 <b>(18'9")</b>	7.62 <b>(25'0")</b>	2.36 <b>(7'9")</b>	3.66 <b>(12'0")</b>	10.74 <b>(35'3")</b>	Mech.	29.3 <b>(18.2)</b>	9.3 <b>(5.8)</b>
112F	82F(U.S.) 46D(U.S.) 74H(U.S.) 89J(U.S.) 80J(AUSTL)	60-64 64-68 67-68 68-74 69-84	100	9800 <b>(21,600)</b>	5.72 <b>(18'9")</b>	7.82 <b>(25'8")</b>	2.36 <b>(7'9")</b>	3.66 <b>(12'0")</b>	10.70 <b>(35'3")</b>	Mech.	29.9 <b>(18.6)</b>	9.7 <b>(6.0)</b>
120	89G(U.S.)	64-67	115	10 480 <b>(23,100)</b>	5.71 <b>(18'9")</b>	7.62 <b>(25'0")</b>	2.36 <b>(7'9")</b>	3.66 <b>(12'0")</b>	10.74 <b>(35'3")</b>	Mech.	32.2 <b>(20.0)</b>	10.3 <b>(6.4)</b>
120	14K(U.S.)	67-69	125	10 600 <b>(23,500)</b>	5.71 <b>(18'9")</b>	7.80 <b>(25'8")</b>	2.36 <b>(7'9")</b>	3.66 <b>(12'0")</b>	10.74 <b>(35'3")</b>	Mech.	32.2 <b>(20.0)</b>	41.5 <b>(25.8)</b>
120	10R(U.S.)	69-74	125	10 700 <b>(23,700)</b>	5.85 <b>(19'2")</b>	7.95 <b>(26'1")</b>	2.36 <b>(7'9")</b>	3.66 <b>(12'0")</b>	10.90 <b>(35'9")</b>	Mech.	32.2 <b>(20.0)</b>	6.6 <b>(4.1)</b>
120	13U(U.S.)	71-74	125	11 000 <b>(24,300)</b>	5.85 <b>(19'2")</b>	7.95 <b>(26'1")</b>	2.36 <b>(7'9")</b>	3.66 <b>(12'0")</b>	10.90 <b>(35'9")</b>	Mech.	32.2 <b>(20.0)</b>	6.6 <b>(4.1)</b>
120B	64U(BRAZ)	72-89	125	12 000 <b>(26,460)</b>	5.85 <b>(19'2")</b>	7.92 <b>(26'0")</b>	2.36 <b>(7'9")</b>	3.66 <b>(12'0")</b>	10.90 <b>(35'9")</b>	Mech.	35.4 <b>(22.0)</b>	23.8 <b>(14.8)</b>
120G	87V(U.S.) 4HD(BRAZ) 11W(AUSTL) 82V(CAN)	73-95 86-95 75-95 74-80	125	12 859 <b>(28,350)</b>	5.69 <b>(18'8")</b>	7.92 <b>(26'0")</b>	2.45 <b>(8'0")</b>	3.66 <b>(12'0")</b>	6.7 <b>(22'0")</b>	Hyd.	40.9 <b>(25.4)</b>	40.9 <b>(25.4)</b>
120H	4MK(U.S.) 6NM(U.S.) 9YR(BRAZ) 2AN(AUSTL) 3GR(S.AFRICA) 124 (AUSTL) ALZ(U.S.) CAF(BRAZ)	95-02 03-05 02-04 03-07	125/140	12 520 <b>(27,600)</b>	5.86 <b>(19'3")</b>	8.26 <b>(27'1")</b>	2.44 <b>(7'11")</b>	3.66 <b>(12'0")</b>	7.2 <b>(23'8")</b>	Hyd.	42.6 <b>(26.5)</b>	33.7 <b>(20.9)</b>
120H	ALZ(U.S.) CAF(BRAZ) 124(AUSTL)	02-03 02-07 03-05	125/140	12 650 <b>(27,880)</b>	5.92 <b>(19'5")</b>	8.31 <b>(27'3")</b>	2.44 <b>(8'0")</b>	3.66 <b>(12'0")</b>	7.3 <b>(23'7")</b>	Hyd.	42.6 <b>(26.5)</b>	33.7 <b>(20.9)</b>
120H STD	6TM(U.S.) 5FM(BRAZ) 9FN(INDO)	96-99 96-09 96-04	125/140	12 466 <b>(27,483)</b>	5.87 <b>(19'3")</b>	8.15 <b>(26'9")</b>	2.44 <b>(8'0")</b>	3.66 <b>(12'0")</b>	7.2 <b>(23'8")</b>	Hyd.	42.6 <b>(26.5)</b>	33.7 <b>(20.9)</b>

## Motor Graders (cont'd)

Model	Product Ident. No. Prefix	Years Built	Horsepower, Rated	Approx. Ship Wt. kg (lb)	Wheel-base m (ft)	Length m (ft)	Width m (ft)	Mold-board Length m (ft)	Turning Radius m (ft)	Controls	Maximum Speed km/h (mph)	
											Forward	Rev.
130G	74V(U.S.) 12W(AUSTL)	73-95 75-89	135	13 050 (28,770)	5.92 (19'5")	8.30 (27'3")	2.45 (8'0")	3.66 (12'0")	7.3 (24'0")	Hyd.	39.4 (24.5)	39.4 (24.5)
135H	3YK(U.S.) AMX(U.S.) CBC(BRAZ)	95-02 02-04 03-07	135/155	12 950 (28,550)	5.86 (19'3")	8.26 (27'1")	2.44 (7'11")	3.66 (12'0")	7.2 (23'8")	Hyd.	41.9 (26.0)	33.1 (20.6)
135H	AMX(U.S.) CBC(BRAZ)	02-04 02-07	135/155	13 080 (28,840)	5.92 (19'5")	8.31 (27'3")	2.44 (8'0")	3.66 (12'0")	7.3 (23'7")	Hyd.	41.9 (26.1)	33.1 (20.6)
12	6M(U.S.)	39-42	66	9440 (20,820)	5.72 (18'9")	7.62 (25'0")	2.39 (7'10")	3.66 (12'0")	10.87 (35'8")	Mech.	24.5 (15.2)	6.1 (3.8)
12	9K(U.S.)	38-45	70	9590 (21,140)	5.72 (18'9")	7.62 (25'0")	2.39 (7'10")	3.66 (12'0")	10.87 (35'8")	Mech.	24.5 (15.2)	6.1 (3.8)
12	7T(U.S.)	45-47	75	9750 (21,500)	5.72 (18'9")	7.62 (25'0")	2.39 (7'10")	3.66 (12'0")	10.87 (35'8")	Mech.	24.5 (15.2)	6.1 (3.8)
12	8T(U.S.) 94C(AUSTL)	47-55 55-58	100	10 100 (22,375)	5.72 (18'9")	7.62 (25'0")	2.39 (7'10")	3.66 (12'0")	10.87 (35'8")	Mech.	31.1 (19.3)	6.6 (4.1)
12	70D-71D(U.S.) 80C(U.S.) 38E(AUSTL)	57-59 55-67 58-60	115	10 200 (22,410)	5.72 (18'9")	7.62 (25'0")	2.37 (7'10")	3.66 (12'0")	10.87 (35'8")	Mech.	31.1 (19.3)	10.1 (6.3)
12E	99E(U.S.) 21F(AUSTL) 17K(AUSTL)	59-65 60-68 68-75	115	11 100 (24,400)	5.72 (18'9")	8.03 (26'4")	2.36 (7'9")	3.66 (12'0")	10.90 (35'9")	Mech.	32.0 (19.9)	22.2 (13.8)
12F	73G(U.S.)	65-67	115	12 973 (28,600)	6.0 (19'8")	8.20 (26'10")	2.36 (7'9")	3.66 (12'0")	11.40 (37'5")	Hyd. Mech.	32.0 (19.9)	22.2 (13.8)
12F	89H(U.S.) 13K(U.S.)	69-73 67-73	125	12 973 (28,600)	6.00 (19'8")	8.20 (26'10")	2.36 (7'9")	3.65 (12'0")	11.40 (37'5")	Hyd. Mech.	34.3 (21.3)	41.5 (25.8)
12G	61M(U.S.) 3PL(BRAZ) 3WC(AUSTL)	73-95 93-95 85-95	135	13 554 (29,860)	5.92 (19'5")	8.30 (27'3")	2.45 (8'0")	3.66 (12'0")	7.30 (24'0")	Hyd.	39.4 (24.5)	39.4 (24.5)
12H	4XM(U.S.) 2LR(U.S.) 8MN(BRAZ) 2GS(BRAZ) 2WR(AUSTL)	95-02	140	14 247 (31,410)	6.10 (20'0")	8.57 (28'1")	2.44 (7'11")	3.66 (12'0")	7.40 (24'3")	Hyd.	39.7 (24.7)	31.3 (19.5)
12H	AMZ(U.S.) CBK(BRAZ) 125(AUSTL)	02-07 02-07 03-05	145/185	14 200 (31,320)	6.09 (20'0")	8.57 (28'1")	2.44 (8'0")	3.66 (12'0")	7.40 (24'3")	Hyd.	44.0 (27.4)	34.7 (21.6)
12H STD	5ZM(U.S.) 4ER(BRAZ) XZJ(CHINA)	97-98 96-09 06-10	140	14 185 (31,273)	6.09 (20'0")	8.45 (27'9")	2.44 (8'0")	3.66 (12'0")	7.4 (24'3")	Hyd.	41.7 (25.9)	32.9 (20.5)

## Motor Graders (cont'd)

Model	Product Ident. No. Prefix	Years Built	Horsepower, Rated	Approx. Ship Wt. kg (lb)	Wheel-base m (ft)	Length m (ft)	Width m (ft)	Mold-board Length m (ft)	Turning Radius m (ft)	Controls	Maximum Speed km/h (mph)	
											Forward	Rev.
140	14U(U.S.) 11R(U.S.) 55F(AUSTL) 24R(CAN)	71-74 70-74 71-75 71-74	150	13 109 (28,900)	5.84 (19'2")	7.95 (26'1")	2.44 (8'0")	3.66 (12'0")	10.97 (36'0")	Mech.	38.8 (24.1)	47.0 (29.2)
140B	61S(BRAZ)	81-87	150	13 620 (30,003)	6.14 (20'2")	8.07 (26'6")	2.39 (7'10")	3.96 (13'0")	11.60 (38'0")	Mech.	37.6 (23.4)	25.6 (15.9)
140G	72V(U.S.) 5MD(BRAZ) 13W(AUSTL) 81V(CAN)	73-95 87-95 75-95 74-80	150	14 102 (31,090)	5.92 (19'5")	8.33 (27'4")	2.45 (8'0")	3.66 (12'0")	7.30 (24'0")	Hyd.	41.0 (25.5)	41.0 (25.5)
140G AWD	72V(U.S.)	73-95	150	14 914 (32,880)	5.92 (19'5")	8.33 (27'4")	2.45 (8'0")	3.66 (12'0")	7.30 (24'0")	Hyd.	41.0 (25.5)	41.0 (25.5)
140H	2ZK(U.S.) 8KM(U.S.) 9TN(BRAZ) 3AS(BRAZ) 9ZN(AUSTL) APM(U.S.) CCA(BRAZ) 126(AUSTL)	95-02     02-07 02-07 03-05	165/185	14 724 (32,460)	6.10 (20'0")	8.60 (28'3")	2.46 (8'1")	3.66 (12'0")	7.40 (24'3")	Hyd.	41.1 (25.5)	32.4 (20.2)
140H	APM(U.S.) CCA(BRAZ) 126(AUSTL)	02-07 02-07 03-05	165/205	14 677 (32,357)	6.17 (20'3")	8.71 (28'7")	2.46 (8'1")	3.66 (12'0")	7.5 (24'7")	Hyd.	44.0 (27.4)	34.7 (21.6)
140H STD	8JM(U.S.) 5HM(BRAZ) XZH(CHINA)	96-99 96-09 05-10	165/185	14 661 (32,321)	6.09 (20'0")	8.60 (28'3")	2.46 (8'1")	3.66 (12'0")	7.4 (24'3")	Hyd.	41.1 (25.5)	32.4 (20.2)
143H	1AL(U.S.) APN(U.S.)	95-02 02-07	165/185	15 023 (33,120)	6.10 (20'0")	8.60 (28'3")	2.46 (8'1")	3.66 (12'0")	7.40 (24'3")	Hyd.	41.1 (25.5)	32.4 (20.2)
143H	APN(U.S.)	02-07	165/205	15 270 (33,670)	6.17 (20'3")	8.71 (28'7")	2.55 (8'5")	3.66 (12'0")	7.5 (24'7")	Hyd.	44.0 (27.4)	34.7 (21.6)
14B	78E(U.S.) 64C(U.S.)	59-59 59-69	150	13 300 (29,280)	5.84 (19'2")	8.03 (26'4")	2.44 (8'0")	3.66 (12'0")	10.97 (36'0")	Mech.	34.8 (21.6)	11.3 (7.0)
14C	35F(U.S.)	59-61	150	12 973 (28,600)	5.84 (19'2")	8.03 (26'4")	2.44 (8'0")	3.66 (12'0")	10.97 (36'0")	Mech.	34.8 (21.6)	11.3 (7.0)
14D	96F(U.S.)	61-65	150	13 700 (30,300)	6.15 (20'2")	8.33 (27'4")	2.44 (8'0")	3.96 (13'0")	11.58 (38'0")	Mech.	34.1 (21.2)	23.5 (14.6)
14E	99G(U.S.)	65-68	150	13 699 (30,200)	6.15 (20'2")	8.33 (27'4")	2.44 (8'0")	3.96 (13'0")	11.58 (38'0")	Hyd. Mech.	36.4 (22.6)	24.9 (15.5)
14E	12K(U.S.) 72G(U.S.)	67-73 69-73	150	14 300 (31,600)	6.10 (20'2")	8.30 (27'4")	2.44 (8'0")	3.96 (13'0")	11.60 (38'0")	Hyd. Mech.	39.1 (24.3)	47.3 (29.4)
14G	96U(U.S.)	73-95	200	20 688 (45,610)	6.45 (21'2")	9.21 (30'3")	2.83 (9'3")	4.27 (14'0")	7.90 (25'11")	Hyd.	43.0 (26.8)	50.1 (31.1)
14H	7WJ(U.S.) ASE(U.S.)	95-02 02-07	215	18 784 (41,410)	6.45 (21'2")	9.21 (30'2")	2.70 (8'10")	4.27 (14'0")	7.90 (25'11")	Hyd.	42.7 (26.5)	47.3 (29.4)
14H	ASE(U.S.)	02-07	220/240	18 809 (41,465)	6.56 (21'6")	9.34 (30'8")	2.82 (9'3")	4.27 (14'0")	8.0 (26'4")	Hyd.	46.1 (28.7)	51.1 (31.8)



## Motor Graders (cont'd)

Model	Product Ident. No. Prefix	Years Built	Horsepower, Rated	Approx. Ship Wt. kg (lb)	Wheel-base m (ft)	Length m (ft)	Width m (ft)	Mold-board Length m (ft)	Turning Radius m (ft)	Controls	Maximum Speed km/h (mph)	
											Forward	Rev.
160H	9EJ(U.S.) 6WM(U.S.) 3GM(BRAZ) 2HS(BRAZ) ASD(U.S.) CCP(BRAZ)	95-02    02-07 02-07	180/200	15 586 <b>(34,360)</b>	6.10 <b>(20'0")</b>	8.60 <b>(28'3")</b>	2.46 <b>(8'1")</b>	4.27 <b>(14'0")</b>	7.40 <b>(24'3")</b>	Hyd.	40.7 <b>(25.3)</b>	32.1 <b>(20.0)</b>
160H	ASD(U.S.) CCP(BRAZ)	02-07 03-07	180/220	15 676 <b>(34,560)</b>	6.17 <b>(20'3")</b>	8.71 <b>(28'7")</b>	2.48 <b>(8'2")</b>	4.27 <b>(14'0")</b>	7.5 <b>(24'7")</b>	Hyd.	43.6 <b>(27.1)</b>	34.4 <b>(21.4)</b>
160H	9JM(U.S.) STD	96-99 96-98	180/200	15 524 <b>(34,225)</b>	6.09 <b>(20'0")</b>	8.49 <b>(27'10")</b>	2.46 <b>(8'1")</b>	4.27 <b>(14'0")</b>	7.4 <b>(24'3")</b>	Hyd.	40.7 <b>(25.3)</b>	32.1 <b>(20.0)</b>
	XZK(CHINA)	06-10										
163H	5AK(U.S.) ARL(U.S.)	95-02 02-07	180/200	16 538 <b>(36,460)</b>	6.10 <b>(20'0")</b>	8.60 <b>(28'3")</b>	2.46 <b>(8'1")</b>	4.27 <b>(14'0")</b>	7.40 <b>(24'3")</b>	Hyd.	40.7 <b>(25.3)</b>	32.1 <b>(20.0)</b>
163H	ARL(U.S.)	02-07	180/220	16 280 <b>(35,890)</b>	6.17 <b>(20'3")</b>	8.71 <b>(28'7")</b>	2.55 <b>(8'5")</b>	4.27 <b>(14'0")</b>	7.5 <b>(24'7")</b>	Hyd.	43.6 <b>(27.1)</b>	34.4 <b>(21.4)</b>
16	49G(U.S.)	63-73	225	22 499 <b>(49,600)</b>	6.86 <b>(22'6")</b>	9.50 <b>(31'2")</b>	3.00 <b>(9'10")</b>	4.27 <b>(14'0")</b>	13.56 <b>(44'6")</b>	Hyd. Mech.	49.7 <b>(30.9)</b>	49.7 <b>(30.9)</b>
16G	93U(U.S.)	73-95	275	27 284 <b>(60,150)</b>	6.96 <b>(22'10")</b>	9.99 <b>(32'8")</b>	3.08 <b>(10'1")</b>	4.88 <b>(16'0")</b>	8.20 <b>(27'0")</b>	Hyd.	43.6 <b>(27.1)</b>	43.6 <b>(27.1)</b>
16H	6ZJ(U.S.) ATS(U.S.)	95-02 02-07	275	24 748 <b>(54,560)</b>	6.96 <b>(22'10")</b>	9.99 <b>(32'9")</b>	2.99 <b>(9'10")</b>	4.88 <b>(16'0")</b>	8.20 <b>(27'0")</b>	Hyd.	44.5 <b>(27.7)</b>	42.3 <b>(26.3)</b>
16H	ATS(U.S.)	02-07	265/285	24 740 <b>(54,550)</b>	6.96 <b>(22'10")</b>	9.99 <b>(32'9")</b>	3.08 <b>(10'1")</b>	4.88 <b>(16'0")</b>	8.2 <b>(26'11")</b>	Hyd.	48.1 <b>(29.9)</b>	45.7 <b>(28.4)</b>
24H	7KK(U.S.)	96-07	500	61 955 <b>(136,611)</b>	10.23 <b>(33'7")</b>	14.16 <b>(46'6")</b>	4.23 <b>(13'10")</b>	7.3 <b>(24'0")</b>	12.0 <b>(39'11")</b>	Hyd.	37.7 <b>(23.4)</b>	36.1 <b>(22.4)</b>



**SKID STEER LOADERS**

Model	Product Ident. No. Prefix	Years Built	Approx. Machine Weight kg (lb)	Net Power kW (hp)	Length to Coupler mm (in)	Width over Tires mm (in)**	Height to Top of Cab mm (in)	Engine Model	Top Travel Speed km/h (mph)	Rated Operating Capacity	
										Rated Operating Capacity at 50% kg (lb)	Rated Operating Capacity at 50% with counter-weight kg (lb)
216	4NZ	99-03	2490 (5490)	36 (48)	2519 (99)	1525 (60)	1950 (77)	3024C	11.5 (7.0)	635 (1400)	680 (1500)
216B	RLL	04-07	2589 (5709)	37 (49)	2519 (99)	1525 (60)	1950 (77)	3024C	12.7 (7.9)	635 (1400)	680 (1500)
226	5FZ	99-03	2560 (5645)	41 (54)	2519 (99)	1525 (60)	1950 (77)	3034	11.5 (7.0)	680 (1500)	726 (1600)
226B	MJH	04-07	2646 (5834)	42 (57)	2519 (99)	1525 (60)	1950 (77)	3024C T	12.7 (7.9)	680 (1500)	726 (1600)
228	6BZ	99-03	2650 (5843)	41 (54)	2519 (99)	1525 (60)	1950 (77)	3034	11.5 (7.0)	680 (1500)	726 (1600)
232	CAB	02-04	3005 (6627)	36 (48)	2776 (110)	1525 (60)	1953 (77)	3024C	11.1 (7.0)	793 (1750)	815 (1795)
232B	SCH	04-07	3021 (6661)	37 (49)	2760 (109)	1525 (60)	1953 (77)	3024C	11.1 (6.9)	793 (1750)	815 (1795)
236	4YZ	99-03	3134 (6810)	44 (59)	2800 (110)	1676 (66)	2092 (82)	3034	12.1 (7.5)	793 (1750)	839 (1850)
236B	HEN	04-07	3178 (7007)	52 (70)	2800 (110)	1676 (66)	2092 (82)	3044C DIT	12.2/18.6* (7.6/11.6*)	793 (1750)	815 (1850)
242	CMB	02-04	3060 (6748)	41 (54)	2776 (110)	1676 (66)	1986 (78)	3034	11.3 (7.0)	907 (2000)	930 (2045)
242B	BXM	04-07	3085 (6805)	42 (57)	2760 (109)	1676 (66)	1986 (78)	3024C T	12.0 (7.4)	907 (2000)	930 (2045)
246	5SZ	99-03	3214 (7087)	55 (74)	2800 (110)	1676 (66)	2092 (82)	3034 T	12.1 (7.5)	907 (2000)	952 (2100)
246B	PAT	04-07	3239 (7142)	58 (78)	2800 (110)	1676 (66)	2092 (82)	3044C T	12.5/19.1* (7.7/11.8*)	907 (2000)	952 (2100)
248	6LZ	99-03	3328 (7338)	55 (74)	2800 (110)	1676 (66)	2092 (82)	3034 T	12.1 (7.5)	907 (2000)	952 (2100)
248B	SCL	04-07	3320 (7321)	57 (76)	2800 (110)	1676 (66)	2092 (82)	3044C DIT	12.5/19.1* (7.7/11.8*)	907 (2000)	952 (2100)
252	FDG	01-03	3454 (7615)	44 (59)	2776 (110)	1829 (72)	1968 (78)	3034	12.1 (7.5)	1020 (2250)	1043 (2300)
252B	SCP	04-07	3552 (7832)	52 (70)	2902 (114)	1829 (72)	2063 (81)	3044C DIT	11.2/17.8* (6.9/11.0*)	1134 (2500)	1134 (2500)
262	CED	01-03	3472 (7655)	55 (74)	2902 (114)	1829 (72)	2098 (83)	3034 T	12.1 (7.5)	1134 (2500)	1156 (2550)
262B	PDT	04-07	3565 (7861)	58 (78)	2902 (114)	1829 (72)	2063 (81)	3044C DIT	11.6/17.8* (7.2/11.0*)	1225 (2700)	1247 (2750)
268B	LBA	04-07	3626 (7995)	57 (76)	2902 (114)	1829 (72)	2063 (81)	3044C DIT	11.6/17.8* (7.2/11.0*)	1225 (2700)	1247 (2750)

\*With two-speed option.

\*\*Models 216-236B with 254 mm (10") wide tires, 242-268B with 305 mm (12") wide tires.



## MULTI TERRAIN LOADERS

Model	Product Ident. No. Prefix	Years Built	Approx. Machine Weight kg (lb)	Net Power kW (hp)	Length to Coupler mm (in)	Width over Tracks mm (in)*	Height to Top of Cab mm (in)	Engine Model	Top Travel Speed km/h (mph)	Rated Operating Capacity at 50% kg (lb)
247	CML	02-04	3023 <b>(6665)</b>	41 <b>(54)</b>	2518 <b>(99)</b>	1676 <b>(66)</b>	1990 <b>(78)</b>	3034	12.1 <b>(7.5)</b>	877 <b>(1933)</b>
247B	MTL	04-07	3024 <b>(6668)</b>	42 <b>(57)</b>	2518 <b>(99)</b>	1676 <b>(66)</b>	1990 <b>(78)</b>	3024C T	12.2 <b>(7.6)</b>	885 <b>(1950)</b>
257	CMM	02-04	3460 <b>(7628)</b>	44 <b>(59)</b>	2701 <b>(106)</b>	1676 <b>(66)</b>	2022 <b>(80)</b>	3034 T	12.1 <b>(7.5)</b>	1046 <b>(2306)</b>
257B	SLK	04-07	3428 <b>(7559)</b>	42 <b>(57)</b>	2701 <b>(106)</b>	1676 <b>(66)</b>	2022 <b>(80)</b>	3024C T	11.4 <b>(7.1)</b>	1047 <b>(2310)</b>
267	CMP	01-04	4134 <b>(9088)</b>	44 <b>(59)</b>	2923 <b>(115)</b>	1898 <b>(75)</b>	2074 <b>(82)</b>	3034	9.7 <b>(6.0)</b>	1315 <b>(2900)</b>
267B	CYC	04-07	4250 <b>(9371)</b>	52 <b>(70)</b>	2923 <b>(115)</b>	1898 <b>(75)</b>	2074 <b>(82)</b>	3044C DIT	11.2 <b>(7.0)</b>	1315 <b>(2900)</b>
277	CNC	01-04	4148 <b>(9126)</b>	55 <b>(74)</b>	2923 <b>(115)</b>	1898 <b>(75)</b>	2074 <b>(82)</b>	3034 T	9.7 <b>(6.0)</b>	1338 <b>(2950)</b>
277B	MDH	04-07	4269 <b>(9411)</b>	58 <b>(78)</b>	2923 <b>(115)</b>	1898 <b>(75)</b>	2074 <b>(82)</b>	3044C DIT	11.2 <b>(7.0)</b>	1338 <b>(2950)</b>
287	CNY	03-04	4471 <b>(9870)</b>	55 <b>(74)</b>	2900 <b>(114)</b>	1962 <b>(77)</b>	2122 <b>(84)</b>	3034 T	11.0 <b>(7.0)</b>	1587 <b>(3500)</b>
287B	ZSA	04-07	4660 <b>(10,275)</b>	58 <b>(78)</b>	2900 <b>(114)</b>	1962 <b>(77)</b>	2122 <b>(84)</b>	3044C DIT	11.2 <b>(7.0)</b>	1632 <b>(3600)</b>

\*With 457 mm (18") wide track.



## HYDRAULIC EXCAVATORS (Track)

Model	Product Ident. No. Prefix COSA (US)	Years Built	Flywheel Horsepower	Approx. Operating Weight kg (lb)	Track Gauge m (ft)	Height* m (ft)	Length* m (ft)	Width m (ft)	Max. Reach** m (ft)	Lift Capacity*** kg (lb)
205 LC	(3HC) (4DC)	84-89	Deutz-67 Perkins-71	13 135 (28,957)	1.895 (6'2.5")	3.00 (9'10")	7.30 (23'11")	2.40 (7'10")	8.17 (26'10")	3290 (7300)
205B	5ZF	90-92	80	12 900 (28,443)	1.895 (6'2.5")	2.976 (9'9")	7.67 (25'2")	2.495 (8'2")	8.9 (29'2")	3740 (8250)
211 LC	(4EC) (5CC)	84-89	Deutz-84 Perkins-94	15 540 (34,260)	2.08 (6'9.9")	3.02 (9'11")	8.01 (26'3")	2.49 (8'2")	9.88 (32'5")	4240 (9340)
213 LC	3ZC	83-87	102	17 300 (38,140)	2.08 (6'10")	3.08 (10'1")	8.34 (27'4")	2.49 (8'2")	10.30 (33'9.5")	5127 (11,305)
215	(96L) (57Z) (14Z)	76-80 79-84	85 90	17 450 (38,480)	1.92 (6'4")	3.10 (10'1")	8.94 (29'4")	2.47 (8'0")	9.25 (30'4")	5090 (11,200)
215 SA	(57Y) (14Z)	82-84	90	19 440 (42,860)	2.18 (7'2")	3.22 (10'6")	8.94 (29'4")	2.73 (8'11")	9.23 (30'3")	5130 (11,300)
215B LC	(9YB)	84-87	105	18 510 (40,806)	1.92 (6'4")	3.10 (10'2")	8.94 (29'4")	2.44 (8'0")	9.25 (30'4")	5760 (12,700)
215C LC	(4HG)	87-89	115	19 570 (43,150)	1.92 (6'4")	3.1 (10'2")	8.94 (29'4")	2.42 (7'11")	9.29 (30'6")	7070 (15,200)
215D LC	(9TF)	89-92	125	19 900 (43,900)	1.92 (6'4")	3.2 (10'6")	9.0 (24'6")	2.44 (8'0")	9.23 (30'3")	6830 (14,700)
219	(5CF)	87-89	130	21 120 (46,550)	2.18 (7'2")	3.12 (10'3")	8.94 (29'4")	2.73 (8'11")	10.39 (34'1")	7080 (15,300)
219D	(5XG)	89-92	140	21 600 (47,500)	2.18 (7'2")	3.12 (10'3")	9.41 (30'10")	2.73 (8'11")	9.75 (32'0")	7670 (16,500)
219 LC	(5CF)	87-89	130	22 020 (48,550)	2.18 (7'2")	3.12 (10'3")	8.94 (29'4")	2.73 (8'11")	10.39 (34'1")	7080 (15,300)
219D LC	(5XG)	89-92	140	22 400 (49,300)	2.18 (7'2")	3.12 (10'3")	9.41 (30'10")	2.73 (8'11")	9.75 (32'0")	7670 (16,500)
225 LC	(51U)	72-86	135	23 900 (52,700)	2.64 (8'8")	3.17 (10'5")	9.83 (32'3")	2.99 (9'10")	9.58 (31'5")	7300 (15,600)
225 SA	(51U)	77-86	135	27 125 (59,800)	2.64 (8'8")	3.17 (10'5")	9.83 (32'3")	3.35 (11'0")	9.55 (31'4")	7340 (15,700)
225B	(2ZD) (3YD)	86-89 87-89	145	24 960 (55,030)	2.44 (8'0")	3.17 (10'5")	9.83 (32'3")	2.99 (9'10")	10.16 (33'4")	11 040 (26,100)
225D	(6RG)	89-91	150	25 400 (55,900)	2.44 (8'0")	3.23 (10'7")	9.94 (32'7")	2.99 (9'10")	10.13 (33'3")	—
225B LC	(2ZD) (3YD)	86-89 87-89	145	26 140 (58,230)	2.44 (8'0")	3.17 (10'5")	9.83 (32'3")	2.99 (9'10")	10.16 (33'4")	11 040 (26,100)
225D LC	(2SJ)	89-91	165	26 700 (58,900)	2.44 (8'0")	3.23 (10'7")	9.94 (32'7")	2.99 (9'10")	10.13 (33'3")	12 450 (26,900)

\*When shipped with medium stick and bucket curled under.

\*\*Maximum reach at ground level, one-piece boom, longest stick.

\*\*\*Lift capacity at 4.6 m (15'0") over front, one-piece boom, longest stick.

## Hydraulic Excavators (Track) (cont'd)

Model	Product Ident. No. Prefix COSA (US)	Years Built	Flywheel Horsepower	Approx. Operating Weight kg (lb)	Track Gauge m (ft)	Height* m (ft)	Length* m (ft)	Width m (ft)	Max. Reach** m (ft)	Lift Capacity*** kg (lb)
229	(1GF) (1AF)	86-89 86-89	145	29 140 <b>(64,830)</b>	2.64 <b>(8'8")</b>	3.38 <b>(11'1")</b>	9.83 <b>(32'3")</b>	3.45 <b>(11'4")</b>	10.11 <b>(33'2")</b>	—
229 LC Custom 180	(1GF)	86-89	180	33 540 <b>(73,940)</b>	2.64 <b>(8'8")</b>	3.38 <b>(11'1")</b>	11.02 <b>(36'2")</b>	3.45 <b>(11'4")</b>	11.35 <b>(37'3")</b>	7940 <b>(17,100)</b>
229D	(2LJ)	89-91	157	31 700 <b>(69,900)</b>	2.64 <b>(8'8")</b>	3.52 <b>(11'7")</b>	10.9 <b>(35'9")</b>	3.25 <b>(10'8")</b>	10.76 <b>(35'4")</b>	8300 <b>(18,300)</b>
231D		90-92	200	34 300 <b>(75,600)</b>	2.64 <b>(8'8")</b>	3.45 <b>(11'4")</b>	10.83 <b>(35'6")</b>	3.45 <b>(11'4")</b>	11.20 <b>(36'9")</b>	15 300 <b>(33,000)</b>
231D LC		90-92	200	35 500 <b>(78,100)</b>	2.64 <b>(8'8")</b>	3.45 <b>(11'4")</b>	10.83 <b>(35'6")</b>	3.45 <b>(11'4")</b>	11.20 <b>(36'9")</b>	15 300 <b>(33,000)</b>
235	(32K) (64R)	73-86	195	39 320 <b>(86,700)</b>	2.69 <b>(8'10")</b>	3.40 <b>(11'2")</b>	11.27 <b>(37'0")</b>	3.45 <b>(11'4")</b>	11.23 <b>(36'10")</b>	7050 <b>(17,300)</b>
235B	(7WC) (9PC)	86-88	215	40 960 <b>(89,700)</b>	2.69 <b>(8'10")</b>	3.40 <b>(11'2")</b>	11.27 <b>(37'0")</b>	3.45 <b>(11'4")</b>	11.23 <b>(36'10")</b>	9934 <b>(21,900)</b>
235C	(4DG) (5AF) (2PG) (3WG)	88-92	250	42 140 <b>(92,800)</b>	2.69 <b>(8'10")</b>	3.50 <b>(11'4")</b>	11.50 <b>(37'7")</b>	3.45 <b>(11'4")</b>	12.00 <b>(39'5")</b>	14 720 <b>(35,000)</b>
235D	(8KJ) (8TJ)	92-93	250	46 270 <b>(103,780)</b>	2.69 <b>(8'10")</b>	3.50 <b>(11'5")</b>	11.50 <b>(37'7")</b>	3.45 <b>(11'4")</b>	12.00 <b>(39'5")</b>	14 840 <b>(35,200)</b>
235D LC	(8KJ) (8TJ)	92-93	250	49 270 <b>(108,620)</b>	3.30 <b>(10'10")</b>	3.60 <b>(11'9")</b>	11.60 <b>(38'1")</b>	3.79 <b>(12'5")</b>	11.97 <b>(39'3")</b>	15 070 <b>(35,700)</b>
245	(82X) (84X)	74-88	325	65 745 <b>(144,941)</b>	3.24 <b>(10'7")</b>	4.62 <b>(15'2")</b>	13.18 <b>(43'3")</b>	3.71 <b>(12'2")</b>	14.02 <b>(46'0")</b>	14 930 <b>(32,920)</b>
245B	6MF 1SJ	88-92	360	65 200 <b>(143,500)</b>	3.24 <b>(10'7")</b>	4.78 <b>(15'8")</b>	13.13 <b>(43'1")</b>	3.61 <b>(11'10")</b>	14.02 <b>(46'0")</b>	—
245D	(4LK) (7ZJ)	92-93	385	68 420 <b>(150,520)</b>	3.24 <b>(10'7")</b>	5.46 <b>(17'11")</b>	12.82 <b>(42'0")</b>	3.61 <b>(11'10")</b>	13.84 <b>(45'9")</b>	14 640† <b>(31,600)</b>
E70	3BG 3CG	87-89 87-89	52	6500 <b>(14,300)</b>	1.65 <b>(5'5")</b>	2.59 <b>(8'6")</b>	6.02 <b>(19'9")</b>	2.25 <b>(7'5")</b>	6.67 <b>(21'10")</b>	1300 <b>(2750)</b>
E70B	7YF(JPN) 5TG(OSJ) 6AK(OSJ)	89-94 89-94 92-94	54	6760 <b>(14,900)</b>	1.75 <b>(5'9")</b>	2.56 <b>(8'5")</b>	6.09 <b>(20'0")</b>	2.32 <b>(7'7")</b>	6.72 <b>(22'1")</b>	1315 <b>(2900)</b>
E110	3FG 3GG	87-89 87-89	74	10 700 <b>(23,600)</b>	1.9 <b>(6'3")</b>	2.73 <b>(8'11")</b>	7.345 <b>(24'0")</b>	2.5 <b>(8'2")</b>	7.93 <b>(26'0")</b>	2700 <b>(5750)</b>
E110B	9HF(OSJ) 8MF(JPN) 5GK(OSJ)	90-92 90-92 90-92	79	11 600 <b>(25,600)</b>	1.99 <b>(6'6")</b>	2.70 <b>(8'10")</b>	7.25 <b>(23'9")</b>	2.495 <b>(8'2")</b>	8.10 <b>(26'7")</b>	3350 <b>(7200)</b>
E120	1LF(OSJ) 1MF(JPN)	87-89 87-89	84	12 200 <b>(26,800)</b>	1.99 <b>(6'6")</b>	2.775 <b>(9'1")</b>	7.66 <b>(25'1")</b>	2.490 <b>(8'2")</b>	8.58 <b>(28'2")</b>	3850 <b>(8300)</b>
E120B	7NF(OSJ) 6JF(JPN) 4XK(OSJ)	90-92 90-92 90-92	84	12 680 <b>(28,200)</b>	1.99 <b>(6'6")</b>	2.70 <b>(8'10")</b>	7.62 <b>(25'10")</b>	2.495 <b>(8'2")</b>	8.74 <b>(28'8")</b>	4310 <b>(9250)</b>
E140	1PF(JPN) 1NF(OSJ)	87-94	89	13 970 <b>(30,800)</b>	1.99 <b>(6'6")</b>	2.89 <b>(9'6")</b>	8.29 <b>(27'6")</b>	2.55 <b>(8'4")</b>	5.49 <b>(18'0")</b>	4380 <b>(9650)</b>

\*When shipped with medium stick and bucket curled under.

\*\*Maximum reach at ground level, one-piece boom, longest stick.

\*\*\*Lift capacity at 4.6 m (15'0") over front, one-piece boom, longest stick.

†Lift capacity at 7.5 m (25'0") over front, one-piece boom, longest stick.

## Hydraulic Excavators (Track) (cont'd)

Model	Product Ident. No. Prefix COSA (US)	Years Built	Flywheel Horsepower	Approx. Operating Weight kg (lb)	Track Gauge m (ft)	Height* m (ft)	Length* m (ft)	Width m (ft)	Max. Reach** m (ft)	Lift Capacity*** kg (lb)
E200B	6KF(OSJ) 4SG(JPN)	87-91 87-91	118	18 800 <b>(41,400)</b>	2.20 <b>(7'3")</b>	2.97 <b>(9'9")</b>	9.48 <b>(31'11")</b>	2.83 <b>(9'4")</b>	10.63 <b>(34'10")</b>	8100 <b>(17,350)</b>
EL200B	7DF(OSJ) 5EG(JPN)	87-91 87-91	118	20 100 <b>(44,300)</b>	2.38 <b>(7'10")</b>	2.97 <b>(9'9")</b>	9.48 <b>(31'11")</b>	3.18 <b>(10'5")</b>	10.63 <b>(34'10")</b>	8150 <b>(17,600)</b>
E240	1FG(OSJ) 2HF(JPN)	87-89 87-89	148	23 000 <b>(50,700)</b>	2.39 <b>(7'10")</b>	3.02 <b>(9'11")</b>	9.73 <b>(31'11")</b>	3.19 <b>(10'6")</b>	10.6 <b>(34'9")</b>	9800 <b>(21,600)</b>
E240B	8SF(OSJ) 9PF(JPN)	89-92	148	23 000 <b>(50,700)</b>	2.39 <b>(7'10")</b>	3.02 <b>(9'11")</b>	9.73 <b>(31'11")</b>	3.19 <b>(10'6")</b>	10.6 <b>(34'9")</b>	9800 <b>(21,600)</b>
E240C	2RL(OSJ) 8MK(JPN)	92-93	148	23 000 <b>(50,700)</b>	2.39 <b>(7'10")</b>	3.02 <b>(9'11")</b>	9.73 <b>(31'11")</b>	3.19 <b>(10'6")</b>	10.6 <b>(34'9")</b>	9800 <b>(21,600)</b>
EL240	4JF(OSJ) 4MF(JPN)	87-89 87-89	148	23 600 <b>(52,000)</b>	2.58 <b>(8'6")</b>	3.02 <b>(9'11")</b>	9.73 <b>(31'11")</b>	3.38 <b>(11'1")</b>	10.6 <b>(34'9")</b>	11 300 <b>(24,300)</b>
EL240B	5WG(OSJ) 6MG(JPN)	89-92	148	23 600 <b>(52,000)</b>	2.58 <b>(8'6")</b>	3.02 <b>(9'11")</b>	9.73 <b>(31'11")</b>	3.38 <b>(11'1")</b>	10.6 <b>(34'9")</b>	10 320 <b>(22,750)</b>
EL240C	9PK(OSJ) 9NK(JPN)	92-93	148	23 600 <b>(52,000)</b>	2.58 <b>(8'6")</b>	3.02 <b>(9'11")</b>	9.73 <b>(31'11")</b>	3.38 <b>(11'1")</b>	10.6 <b>(34'9")</b>	10 320 <b>(22,750)</b>
E300	2CF(OSJ) 1KG(JPN)	87-89 87-89	187	30 500 <b>(67,300)</b>	2.6 <b>(8'6")</b>	3.22 <b>(10'7")</b>	10.94 <b>(35'11")</b>	3.4 <b>(11'2")</b>	11.84 <b>(38'9")</b>	12 550 <b>(27,650)</b>
E300B	1WJ(OSJ) 2HJ(JPN)	90-91 90-91	206	30 200 <b>(66,580)</b>	2.6 <b>(8'6")</b>	3.22 <b>(10'7")</b>	10.94 <b>(35'11")</b>	3.4 <b>(11'2")</b>	11.84 <b>(38'9")</b>	12 450 <b>(26,850)</b>
EL300	4NF(OSJ) 4SF(JPN)	87-89 87-89	187	31 600 <b>(69,700)</b>	2.6 <b>(8'6")</b>	3.22 <b>(10'7")</b>	10.94 <b>(35'11")</b>	3.4 <b>(11'2")</b>	11.84 <b>(38'9")</b>	12 550 <b>(27,650)</b>
EL300B	3FJ(OSJ) 1GK(JPN)	90-91 90-91	206	31 200 <b>(68,780)</b>	2.6 <b>(8'6")</b>	3.22 <b>(10'7")</b>	10.94 <b>(35'11")</b>	3.4 <b>(11'2")</b>	11.84 <b>(38'9")</b>	12 450 <b>(26,850)</b>
E450	3HG(OSJ) 3JG(JPN)	87-93 87-93	276	46 000 <b>(101,430)</b>	2.89 <b>(9'6")</b>	3.49 <b>(11'5")</b>	11.96 <b>(39'3")</b>	3.15 <b>(10'4")</b>	13.08 <b>(42'11")</b>	10 900 <b>(23,500)</b>
E650	3KG(OSJ) 3LG(JPN)	87-92 87-92	375	62 600 <b>(138,000)</b>	3.25 <b>(10'8")</b>	4.84 <b>(15'11")</b>	14.0 <b>(45'11")</b>	3.49 <b>(11'5")</b>	13.33 <b>(43'9")</b>	15 850 <b>(34,000)</b>
301.5	3YW	98-05	17.4	1650 <b>(3640)</b>	0.75 <b>(2'6")</b>	2.19 <b>(7'2")</b>	3.69 <b>(12'1")</b>	0.98 <b>(3'3")</b>	3.8 <b>(12'6")</b>	380† <b>(830)</b>
301.6	BDH	00-05	17.4	1690 <b>(3726)</b>	0.75 <b>(2'6")</b>	2.19 <b>(7'2")</b>	3.69 <b>(12'1")</b>	0.98 <b>(3'3")</b>	3.8 <b>(12'6")</b>	370† <b>(810)</b>
301.8	BFA	00-05	17.4	1725 <b>(3803)</b>	0.75 <b>(2'6")</b>	2.19 <b>(9'8")</b>	3.69 <b>(12'1")</b>	0.98 <b>(3'3")</b>	3.8 <b>(12'6")</b>	370† <b>(810)</b>
302.5	4AZ	99-05	22.9	2730 <b>(6020)</b>	1.15 <b>(3'9")</b>	2.3 <b>(7'7")</b>	4.52 <b>(14'10")</b>	1.45 <b>(4'9")</b>	4.83 <b>(15'10")</b>	870† <b>(1910)</b>
303 CR	DMA	01-05	26.1	3210 <b>(7077)</b>	1.25 <b>(4'1")</b>	2.48 <b>(8'2")</b>	4.68 <b>(15'4")</b>	1.55 <b>(5'1")</b>	5.39 <b>(17'8")</b>	1200† <b>(2646)</b>
303.5	AFW DCH	99-02 01-02	25	7430 <b>(7546)</b>	1.25 <b>(4'1")</b>	2.44 <b>(8'0")</b>	5.07 <b>(16'6")</b>	1.55 <b>(5'1")</b>	5.54 <b>(18'2")</b>	1030† <b>(2270)</b>

\*When shipped with medium stick and bucket curled under.

\*\*Maximum reach at ground level, one-piece boom, longest stick.

\*\*\*Lift capacity at 4.6 m (15'0") over front, one-piece boom, longest stick.

†Lift capacity at 7.5 m (25'0") over front, one-piece boom, longest stick.

## Hydraulic Excavators (Track) (cont'd)

Model	Product Ident. No. Prefix COSA (US)	Years Built	Flywheel Horsepower	Approx. Operating Weight kg (lb)	Track Gauge m (ft)	Height* m (ft)	Length* m (ft)	Width m (ft)	Max. Reach** m (ft)	Lift Capacity*** kg (lb)
304 CR	NAD	02-05	35.5	4300 (9480)	1.58 (5'2")	2.6 (8'6")	5.18 (17'0")	1.98 (6'6")	5.95 (19'6")	2250† (5000)
304.5	ANK WAK	99-02 01-02	38	4475 (9866)	1.5 (4'11")	2.5 (8'4")	5.7 (18'8")	1.9 (6'6")	6.05 (19'10")	1600† (3630)
305 CR	DSA	01-03	42	4800 (10,582)	1.58 (5'2")	2.6 (8'6")	5.37 (17'7")	1.98 (6'6")	6.14 (20'2")	2550† (5622)
	DGT	03-05	42	4800 (10,582)	1.58 (5'2")	2.6 (8'6")	5.37 (17'7")	1.98 (6'6")	6.14 (20'2")	2550† (5622)
307	2WM	94-98	54	7600 (16,760)	1.75 (5'9")	2.61 (8'7")	6.3 (20'8")	2.4 (7'11")	6.38 (20'11")	2450 (5400)
	2PM(OSJ)	94-98	54	6740 (14,860)	1.75 (5'9")	2.63 (8'8")	6.08 (19'11")	2.28 (7'6")	6.72 (22'1")	1350 (3000)
	9ZL(JPN)	94-97	54	6650 (14,660)	1.75 (5'9")	2.63 (8'8")	6.08 (19'11")	2.28 (7'6")	6.72 (22'1")	1350 (3000)
307B	5CW(OSJ)	98-00	54	6960 (15,340)	1.75 (5'9")	2.63 (8'8")	6.08 (19'11")	2.28 (7'6")	6.72 (22'1")	1350 (3000)
	4RW(JPN)	97-00	54	6500 (14,330)	1.75 (5'9")	2.64 (8'8")	6.08 (19'11")	2.28 (7'6")	6.72 (22'1")	1350 (3000)
307B SB	AFB	99-00	40/54	7500 (16,530)	1.75 (5'9")	2.9 (9'6")	6.75 (22'2")	2.28 (7'6")	7.01 (23'0")	1410 (3100)
	6KZ(OSJ) 7DZ(JPN)	98-01	40/54	8040 (17,730)	1.75 (5'9")	2.64 (8'8")	6.73 (22'1")	2.28 (7'6")	7.42 (24'4")	1500 (3300)
307C	(BCM)	00-	54	7210 (15,900)	1.75 (5'9")	2.78 (9'1")	6.07 (19'11")	2.29 (7'6")	6.85 (22'6")	947 (2100)
	BAJ	00-	54	6450 (14,220)	1.75 (5'9")	2.63 (8'8")	6.07 (19'11")	2.29 (7'6")	6.34 (20'10")	1052 (2300)
307C SB	(BNE)	00-07	54	8390 (18,500)	1.75 (5'9")	2.63 (8'8")	6.79 (22'3")	2.29 (7'6")	7.55 (24'9")	822 (1800)
308B CR	3YS(JPN)	99-02	54	7650 (16,870)	1.85 (6'1")	2.61 (8'7")	5.77 (18'11")	2.3 (7'7")	6.9 (22'8")	1600 (3500)
308C CR	(KCX)	02-07	54	8040 (17,730)	1.87 (6'2")	2.61 (8'7")	5.83 (19'2")	2.47 (8'1")	6.9 (22'8")	947 (2100)
	CPE	01-	54	7390 (16,290)	1.87 (6'2")	2.61 (8'7")	5.83 (19'2")	2.32 (7'7")	6.39 (21'0")	1135 (2500)
311	9LJ(OSJ)	93-96	79	11 100 (24,470)	1.99 (6'6")	2.76 (9'1")	7.25 (23'9")	2.49 (8'2")	8.1 (26'7")	3100 (6800)
	5PK(JPN)	93-96	79	11 050 (24,360)	1.99 (6'6")	2.76 (9'1")	7.25 (23'9")	2.49 (8'2")	8.10 (26'7")	3100 (6800)

\*When shipped with medium stick and bucket curled under.

\*\*Maximum reach at ground level, one-piece boom, longest stick.

\*\*\*Lift capacity at 4.6 m (15'0") over front, one-piece boom, longest stick.

†Lift capacity at 3 m (10'0") over front, blade down, one-piece boom, longest stick.

## Hydraulic Excavators (Track) (cont'd)

Model	Product Ident. No. Prefix COSA (US)	Years Built	Flywheel Horsepower	Approx. Operating Weight kg (lb)	Track Gauge m (ft)	Height* m (ft)	Length* m (ft)	Width m (ft)	Max. Reach** m (ft)	Lift Capacity*** kg (lb)
311B	2LS(blade) (OSJ)	96-01	79	11 890 (26,210)	1.99 (6'6")	2.76 (9'1")	7.25 (23'9")	2.495 (8'2")	8.1 (26'7")	3080 (6800)
	2MS(blade) (JPN)	96-01	79	11 900 (26,230)	1.99 (6'6")	2.76 (9'1")	7.25 (23'9")	2.5 (8'2")	8.1 (26'7")	3100 (6800)
	8GR(OSJ)	96-01	79	11 130 (24,540)	1.99 (6'6")	2.76 (9'1")	7.25 (23'9")	2.495 (8'2")	8.1 (26'7")	3120 (6900)
	8HR(JPN)	96-01	79	11 200 (24,690)	1.99 (6'6")	2.76 (9'1")	7.25 (23'9")	2.49 (8'2")	8.1 (26'7")	3100 (6800)
311C U	(CKE)	01-07	79	11 980 (26,410)	1.99 (6'6")	2.77 (9'1")	6.92 (22'8")	2.49 (8'2")	8.225 (27'0")	1295 (2900)
	CLK	01-07	79	11 500 (25,350)	1.99 (6'6")	2.765 (9'1")	6.88 (22'7")	2.49 (8'2")	7.7 (25'3")	1453 (3200)
311D LRR	(DDW)CLA	08-	80	12 710 (28,021)	1.99 (6'6")	3.16 (10'4")	6.83 (22'5")	2.49 (8'2")	8.10 (26'7")	4000 (8550)
312	6BL	93-97	84	12 600 (27,780)	1.99 (6'6")	2.76 (9'1")	7.6 (24'11")	2.49 (8'2")	8.63 (28'4")	4200 (9300)
	6GK(OSJ)	93-96								
	7DK(JPN)	93-96	84	12 000 (26,460)	1.99 (6'6")	2.76 (9'1")	7.6 (24'11")	2.49 (8'2")	8.63 (28'4")	4050 (8900)
312B	6SW	98-01	84	13 000 (28,660)	1.99 (6'6")	2.91 (9'7")	7.59 (24'11")	2.49 (8'2")	8.3 (27'3")	4590 (10,110)
	9GR(OSJ)	98-01	84	12 440 (27,430)	1.99 (6'6")	2.76 (9'1")	7.595 (24'11")	2.495 (8'2")	8.625 (28'4")	4170 (9200)
	9HR(JPN)	98-00	84	12 150 (26,790)	1.99 (6'6")	2.76 (9'1")	7.595 (24'11")	2.49 (8'2")	8.625 (28'4")	4050 (8900)
	9NW(blade)	98-01	66/88	13 785 (30,390)	1.99 (6'6")	2.91 (9'7")	7.59 (24'11")	2.49 (8'2")	8.3 (27'3")	4940 (10,900)
	2NS(blade) (OSJ)	98-01	66/88	13 200 (29,100)	1.99 (6'6")	2.76 (9'1")	7.595 (24'11")	2.495 (8'2")	8.625 (28'4")	4230 (9300)
	3ES(blade) (JPN)	98-00	84	12 900 (28,440)	1.99 (6'6")	2.76 (9'1")	7.595 (24'11")	2.49 (8'2")	8.625 (28'4")	4200 (9300)
	312B L	9FS	97-01	84	13 270 (29,260)	1.99 (6'6")	2.91 (9'7")	7.59 (24'11")	2.59 (8'6")	8.3 (27'3")
8JR(OSJ)		98-01	66/88	12 940 (28,530)	1.99 (6'6")	2.76 (9'1")	7.595 (24'11")	2.59 (8'6")	8.625 (28'4")	4930 (10,900)
2KW(blade)		97-01	84	14 055 (30,990)	1.99 (6'6")	2.91 (9'7")	7.59 (24'11")	2.59 (8'6")	8.3 (27'3")	5050 (11,100)
3FS(blade) (OSJ)		98-01	66/88	13 720 (30,250)	1.99 (6'6")	2.76 (9'1")	7.595 (24'11")	2.59 (8'6")	8.625 (28'4")	4920 (10,800)

\*When shipped with medium stick and bucket curled under.

\*\*Maximum reach at ground level, one-piece boom, longest stick.

\*\*\*Lift capacity at 4.6 m (15'0") over front, one-piece boom, longest stick.



## Hydraulic Excavators (Track) (cont'd)

Model	Product Ident. No. Prefix COSA (US)	Years Built	Flywheel Horsepower	Approx. Operating Weight kg (lb)	Track Gauge m (ft)	Height* m (ft)	Length* m (ft)	Width m (ft)	Max. Reach** m (ft)	Lift Capacity*** kg (lb)
312C	BNN(FDS)	01-07	90	12 860 <b>(28,350)</b>	1.99 <b>(6'6")</b>	2.76 <b>(9'1")</b>	7.57 <b>(24'10")</b>	2.59 <b>(8'6")</b>	8.74 <b>(28'8")</b>	1402 <b>(3100)</b>
	CAE	00-	90	12 200 <b>(26,900)</b>	1.99 <b>(6'6")</b>	2.75 <b>(9'0")</b>	7.57 <b>(24'10")</b>	2.49 <b>(8'2")</b>	8.3 <b>(27'3")</b>	1448 <b>(3200)</b>
	BNN	01-	71/96	13 000 <b>(28,665)</b>	1.99 <b>(6'6")</b>	2.91 <b>(9'6")</b>	7.59 <b>(24'11")</b>	2.49 <b>(8'2")</b>	8.3 <b>(27'3")</b>	4350 <b>(10,120)</b>
312C L	CBT(CBA)	01-07	90	13 140 <b>(28,970)</b>	1.99 <b>(6'6")</b>	2.76 <b>(9'1")</b>	7.57 <b>(24'10")</b>	2.59 <b>(8'6")</b>	8.74 <b>(28'8")</b>	1439 <b>(3200)</b>
	CBT	01-	71/96	13 270 <b>(29,260)</b>	1.99 <b>(6'6")</b>	2.91 <b>(9'6")</b>	7.59 <b>(24'11")</b>	2.59 <b>(8'6")</b>	8.3 <b>(27'3")</b>	5040 <b>(11,025)</b>
312D	(HCW)	08-	90	13 150 <b>(29,000)</b>	1.99 <b>(6'6")</b>	2.83 <b>(9'3")</b>	7.61 <b>(25'0")</b>	2.59 <b>(8'6")</b>	8.62 <b>(28'3")</b>	4400 <b>(9400)</b>
312D L	(JBC)	08-	90	13 450 <b>(29,650)</b>	1.99 <b>(6'6")</b>	2.83 <b>(9'3")</b>	7.61 <b>(25'0")</b>	2.59 <b>(8'6")</b>	8.62 <b>(28'3")</b>	5100 <b>(10,950)</b>
313B CR	BAS(OSJ)	00-02	89	13 225 <b>(29,160)</b>	1.99 <b>6'6"</b>	2.82 <b>9'3"</b>	7.17 <b>23'6"</b>	2.49 <b>8'2"</b>	8.55 <b>28'1"</b>	3900 <b>(8600)</b>
	AEX(JPN)	99-02	89	12 750 <b>(28,110)</b>	1.99 <b>6'6"</b>	2.82 <b>9'3"</b>	7.17 <b>23'6"</b>	2.49 <b>8'2"</b>	8.24 <b>27'0"</b>	3900 <b>(8600)</b>
314C CR	(KJA)	02-02	90	14 610 <b>(32,210)</b>	1.99 <b>6'6"</b>	2.81 <b>9'3"</b>	7.28 <b>23'11"</b>	2.59 <b>8'6"</b>	8.765 <b>28'9"</b>	1351 <b>(3000)</b>
	KHB	01-	90	13 500 <b>(29,760)</b>	1.99 <b>6'6"</b>	2.81 <b>9'3"</b>	7.28 <b>23'11"</b>	2.49 <b>8'2"</b>	8.32 <b>27'4"</b>	1527 <b>(3400)</b>
314C LCR	(PCA)	02-02	90	14 810 <b>(32,650)</b>	1.99 <b>6'6"</b>	2.73 <b>9'0"</b>	7.41 <b>24'4"</b>	2.59 <b>8'6"</b>	8.765 <b>28'9"</b>	1372 <b>(3000)</b>
314D CR	(PDP)	08-	90	14 200 <b>(31,310)</b>	1.99 <b>(6'6")</b>	2.91 <b>(9'7")</b>	7.28 <b>(23'11")</b>	2.49 <b>(8'2")</b>	8.63 <b>(28'4")</b>	4350 <b>(9300)</b>
314D LCR	(BYJ)	08-	90	14 400 <b>(31,750)</b>	1.99 <b>(6'6")</b>	2.91 <b>(9'7")</b>	7.41 <b>(24'4")</b>	2.49 <b>(8'2")</b>	8.63 <b>(28'4")</b>	5050 <b>(10,800)</b>
315	3ZM	95-98	99	15 920 <b>(35,100)</b>	1.99 <b>(6'6")</b>	2.88 <b>(9'5")</b>	8.5 <b>(27'11")</b>	2.49 <b>(8'2")</b>	8.21 <b>(26'11")</b>	5300 <b>(11,700)</b>
	4YM(OSJ)	94-97	99	16 330 <b>(36,000)</b>	1.99 <b>(6'6")</b>	2.88 <b>(9'5")</b>	8.5 <b>(27'11")</b>	2.49 <b>(8'2")</b>	9.14 <b>(30'0")</b>	5290 <b>(11,700)</b>
	6XM(JPN)	94-97	99	15 330 <b>(33,800)</b>	1.99 <b>(6'6")</b>	2.88 <b>(9'5")</b>	8.5 <b>(27'11")</b>	2.49 <b>(8'2")</b>	9.14 <b>(30'0")</b>	—
315 L	6YM(OSJ)	94-97	99	15 920 <b>(35,100)</b>	1.99 <b>(6'6")</b>	2.88 <b>(9'5")</b>	8.5 <b>(27'11")</b>	2.59 <b>(8'6")</b>	8.74 <b>(28'8")</b>	6320 <b>(13,900)</b>

\*When shipped with medium stick and bucket curled under.

\*\*Maximum reach at ground level, one-piece boom, longest stick.

\*\*\*Lift capacity at 4.6 m (15'0") over front, one-piece boom, longest stick.

## Hydraulic Excavators (Track) (cont'd)

Model	Product Ident. No. Prefix COSA (US)	Years Built	Flywheel Horsepower	Approx. Operating Weight kg (lb)	Track Gauge m (ft)	Height* m (ft)	Length* m (ft)	Width m (ft)	Max. Reach** m (ft)	Lift Capacity*** kg (lb)
315B	1SW(OSJ)	97-01	99	16 300 <b>(35,940)</b>	1.99 <b>(6'6")</b>	2.88 <b>(9'5")</b>	8.5 <b>(27'11")</b>	2.49 <b>(8'2")</b>	9.14 <b>(30'0")</b>	5500 <b>(12,100)</b>
	2DW(JPN)	97-01	99	15 850 <b>(34,940)</b>	1.99 <b>(6'6")</b>	2.88 <b>(9'5")</b>	8.5 <b>(27'11")</b>	2.49 <b>(8'2")</b>	9.14 <b>(30'0")</b>	—
315B L	5SW	98-	99	16 700 <b>(36,820)</b>	1.995 <b>(6'7")</b>	3.0 <b>(9'10")</b>	8.41 <b>(27'7")</b>	2.49 <b>(8'2")</b>	9.02 <b>(29'7")</b>	6720 <b>(14,800)</b>
	3AW(OSJ) 7RZ(forest) (OSJ)	97-01	80/107	16 700 <b>(36,820)</b>	1.99 <b>(6'6")</b>	2.88 <b>(9'5")</b>	8.47 <b>(27'10")</b>	2.59 <b>(8'6")</b>	9.14 <b>(30'0")</b>	6600 <b>(14,600)</b>
315C	(CFB)	01-02	110	16 400 <b>(36,160)</b>	1.99 <b>(6'6")</b>	2.99 <b>(9'10")</b>	8.52 <b>(27'11")</b>	2.59 <b>(8'6")</b>	9.29 <b>(30'6")</b>	1675 <b>(3700)</b>
	CFL	01-	110	16 000 <b>(35,270)</b>	1.99 <b>(6'6")</b>	2.95 <b>(9'8")</b>	8.52 <b>(27'11")</b>	2.49 <b>(8'2")</b>	8.9 <b>(29'2")</b>	1840 <b>(4100)</b>
	AKE	03-07	110	16 399 <b>(36,160)</b>	1.99 <b>(6'6")</b>	2.88 <b>(9'5")</b>	8.5 <b>(27'11")</b>	2.49 <b>(8'2")</b>	9.14 <b>(30'0")</b>	5650 <b>(12,100)</b>
315C L	(CFT)	01-02	110	16 750 <b>(36,930)</b>	1.99 <b>(6'6")</b>	2.99 <b>(9'10")</b>	8.52 <b>(27'11")</b>	2.59 <b>(8'6")</b>	9.29 <b>(30'6")</b>	1719 <b>(3800)</b>
	CJC	03-07	110	16 748 <b>(36,930)</b>	1.99 <b>(6'6")</b>	2.88 <b>(9'5")</b>	8.5 <b>(27'11")</b>	2.59 <b>(8'6")</b>	9.14 <b>(30'0")</b>	6750 <b>(14,450)</b>
	ANF	03	83/111	16 770 <b>(36,970)</b>	1.99 <b>(6'6")</b>	2.76 <b>(9'0")</b>	8.39 <b>(27'6")</b>	2.49 <b>(8'2")</b>	9.09 <b>(29'9")</b>	7110 <b>(15,675)</b>
315D L	(CJN)	07-	115	17 280 <b>(38,100)</b>	1.99 <b>(6'6")</b>	3.36 <b>(11'0")</b>	8.54 <b>(28'0")</b>	2.59 <b>(8'6")</b>	9.24 <b>(30'3")</b>	7150 <b>(15,350)</b>
317	4MM	95-98	99	17 260 <b>(38,050)</b>	2.15 <b>(7'1")</b>	2.88 <b>(9'5")</b>	8.5 <b>(27'11")</b>	2.75 <b>(9'0")</b>	8.62 <b>(28'3")</b>	4210 <b>(9300)</b>
317B L	9WW	98-	81/109	17 300 <b>(38,146)</b>	2.2 <b>(7'3")</b>	3.04 <b>(9'10")</b>	8.41 <b>(27'6")</b>	2.8 <b>(9'2")</b>	9.1 <b>(29'8")</b>	7100 <b>(15,655)</b>
317 N	9SR	96-98	99	17 220 <b>(37,960)</b>	1.99 <b>(6'6")</b>	2.88 <b>(9'5")</b>	8.5 <b>(27'11")</b>	2.75 <b>(9'0")</b>	8.62 <b>(28'3")</b>	6450 <b>(14,200)</b>
317B LN	6DZ	98-	81/110	17 300 <b>(38,146)</b>	1.995 <b>(6'5")</b>	3.04 <b>(9'10")</b>	8.41 <b>(27'6")</b>	2.49 <b>(8'2")</b>	9.1 <b>(29'8")</b>	7100 <b>(15,655)</b>
318B L	9WW	98-	86/115	17 700 <b>(39,020)</b>	2.2 <b>(7'3")</b>	3.02 <b>(9'11")</b>	8.67 <b>(28'5")</b>	2.8 <b>(9'2")</b>	8.94 <b>(29'4")</b>	8440 <b>(18,600)</b>
	3LR(OSJ)	99-02	86/115	18 390 <b>(40,540)</b>	2.2 <b>(7'3")</b>	3.05 <b>(10'0")</b>	8.72 <b>(28'7")</b>	2.8 <b>(9'2")</b>	9.77 <b>(32'0")</b>	7650 <b>(16,900)</b>
	ADC	99-	86/115	18 500 <b>(40,792)</b>	2.2 <b>(7'3")</b>	3.04 <b>(9'10")</b>	8.69 <b>(28'6")</b>	2.8 <b>(9'2")</b>	9.6 <b>(31'6")</b>	7600 <b>(16,760)</b>
	(3LR)	01-02	86/115	18 360 <b>(40,480)</b>	2.2 <b>(7'3")</b>	2.83 <b>(9'3")</b>	8.69 <b>(28'6")</b>	2.8 <b>(9'2")</b>	9.78 <b>(32'1")</b>	2200 <b>(4900)</b>

\*When shipped with medium stick and bucket curled under.

\*\*Maximum reach at ground level, one-piece boom, longest stick.

\*\*\*Lift capacity at 4.6 m (15'0") over front, one-piece boom, longest stick.

## Hydraulic Excavators (Track) (cont'd)

Model	Product Ident. No. Prefix COSA (US)	Years Built	Flywheel Horsepower	Approx. Operating Weight kg (lb)	Track Gauge m (ft)	Height* m (ft)	Length* m (ft)	Width m (ft)	Max. Reach** m (ft)	Lift Capacity*** kg (lb)
318B LN	6DZ	98-	86/115	17 160 (37,830)	1.995 (6'7")	3.02 (9'11")	8.67 (28'5")	2.495 (8'2")	8.94 (29'4")	7590 (16,700)
	7KZ(OSJ)	99-02	86/115	18 260 (40,260)	2.2 (7'3")	3.05 (10'0")	8.72 (28'7")	2.59 (8'6")	9.77 (32'1")	7600 (16,800)
	AEJ	99-	86/115	18 500 (40,792)	1.995 (6'7")	3.04 (9'10")	8.69 (28'6")	2.49 (8'2")	9.6 (31'6")	7580 (16,710)
	(7KZ)	01-02	86/115	17 990 (39,660)	1.995 (6'7")	3.05 (10'0")	8.72 (28'7")	2.49 (8'2")	9.78 (32'1")	2200 (4900)
318C	BTG	03	94/127	19 560 (43,120)	2.2 (7'2")	2.9 (9'9")	8.9 (29'2")	2.8 (9'2")	9.66 (31'8")	7850 (17,305)
318C L	DAH(MDY)	02-07	94/127	20 160 (44,445)	2.2 (7'2")	2.9 (9'9")	8.9 (29'2")	2.8 (9'2")	9.66 (31'8")	8950 (19,730)
318C N	FAA(GPA)	02-07	94/127	19 280 (42,505)	1.99 (6'6")	2.9 (9'9")	8.9 (29'2")	2.49 (8'2")	9.66 (31'8")	7730 (17,040)
319C LN	KGL	04	94/127	20 080 (44,269)	1.99 (6'6")	2.9 (9'9")	8.9 (29'2")	2.49 (9'2")	9.66 (31'8")	7730 (17,040)
320	7WK(OSJ)	91-96	128	19 120 (42,150)	2.2 (7'3")	2.93 (9'7")	9.37 (30'9")	2.8 (9'2")	10.63 (34'9")	6200 (17,700)
	2DL(OSJ)									
	8LG(OSJ)									
	7GJ(JPN)									
	3XM(JPN)									
320 L	4ZJ(GOS)	91-96	128	20 370 (44,910)	2.38 (7'10")	2.93 (9'7")	9.37 (30'9")	3.18 (10'5")	10.63 (34'9")	8150 (17,600)
	1TL(OSJ)									
	9KK(OSJ)									
	8HJ(JPN)									
	4JM(JPN)									
320 N	3XK(GOS)	94-96	128	20 050 (44,150)	1.90 (6'6")	2.93 (9'7")	9.37 (30'9")	2.59 (8'6")	10.63 (34'9")	8150 (17,600)
	1XM(OSJ)									
320 S	9WG(GOS)	96-00	128	19 400 (42,770)	2.2 (7'2.6")	3.01 (9'10.5")	9.46 (31'4")	2.8 (9'2.2")	10.77 (35'4")	8600 (19,000)
320B	6KM									
320B L	3MR									
	5BR									
320B N	1XS	96-00	128	20 720 (45,680)	2.38 (7'9.7")	3.01 (9'10.5")	9.46 (31'4")	3.18 (10'5.2")	10.77 (35'4")	9200 (20,300)
	4MR									
320B LN	6CR	96-00	128	19 930 (43,940)	2.2 (7'2.6")	3.01 (9'10.5")	9.46 (31'4")	2.5 (8'2.4")	10.77 (35'4")	9100 (20,100)
	7JR									
321B CR	4NR	98-01	128	19 400 (42,770)	2.2 (7'3")	3.1 (10'2")	8.6 (28'3")	2.98 (9'9")	9.68 (31'9")	8250 (18,200)
321B LCR	2AS									
	3YZ									
321B LCR	9CZ(JPN)	98-01	128	22 500 (49,600)	2.38 (7'10")	3.1 (10'2")	8.8 (28'11")	2.98 (9'9")	9.68 (31'9")	10 300 (22,700)
	KGA(OSJ)			02-02	128	23 100 (50,930)	2.38 (7'10")	3.1 (10'2")	8.8 (28'11")	2.98 (9'9")

\*When shipped with medium stick and bucket curled under.

\*\*Maximum reach at ground level, one-piece boom, longest stick.

\*\*\*Lift capacity at 4.6 m (15'0") over front, one-piece boom, longest stick.

## Hydraulic Excavators (Track) (cont'd)

Model	Product Ident. No. Prefix COSA (US)	Years Built	Flywheel Horsepower	Approx. Operating Weight kg (lb)	Track Gauge m (ft)	Height* m (ft)	Length* m (ft)	Width m (ft)	Max. Reach** m (ft)	Lift Capacity*** kg (lb)
322*	7WL(OSJ) 7WL(JPN)	93-96	153	22 650 <b>(50,000)</b>	2.39 <b>(7'10")</b>	3.12 <b>(10'3")</b>	9.95 <b>(32'8")</b>	2.99 <b>(9'10")</b>	10.47 <b>(34'4")</b>	10 400 <b>(22,500)</b>
322B	8MR 3NR	96-01 96-00	153	22 760 <b>(50,180)</b>	2.39 <b>(7'10")</b>	3.28 <b>(10'9")</b>	10.0 <b>(32'10")</b>	2.99 <b>(9'10")</b>	10.47 <b>(34'4")</b>	10 650 <b>(23,500)</b>
322 L*	8CL(OSJ) 8CL(JPN)	93-96	153	23 950 <b>(52,800)</b>	2.59 <b>(8'6")</b>	3.12 <b>(10'3")</b>	9.95 <b>(32'8")</b>	3.39 <b>(11'1")</b>	10.47 <b>(34'4")</b>	10 400 <b>(22,500)</b>
322B L	8NR 5CR	96-01 96-00	153	23 990 <b>(52,890)</b>	2.59 <b>(8'6")</b>	3.28 <b>(10'9")</b>	10.0 <b>(32'10")</b>	3.39 <b>(11'1")</b>	10.47 <b>(34'4")</b>	11 600 <b>(25,600)</b>
322C L	BGR BFK	01-02 02-06	165	24 200 <b>(53,400)</b>	2.59 <b>(8'6")</b>	3.12 <b>(10'3")</b>	9.96 <b>(32'8")</b>	3.39 <b>(11'1")</b>	10.47 <b>(34'4")</b>	11 500 <b>(24,900)</b>
325*	5WK(OSJ) 8NL(OSJ) 8JG(JPN) 5WK(JPN)	91-95 91-95	168 168	25 520 <b>(56,270)</b> 25 520 <b>(56,270)</b>	2.39 <b>(7'10")</b> 2.39 <b>(7'10")</b>	3.24 <b>(10'8")</b> 3.24 <b>(10'8")</b>	10.27 <b>(33'8")</b> 10.27 <b>(33'8")</b>	2.99 <b>(9'10")</b> 2.99 <b>(9'10")</b>	11.50 <b>(37'7")</b> 11.50 <b>(37'7")</b>	11 100 <b>(24,000)</b> 11 000 <b>(24,000)</b>
325 L*	6KK(OSJ) 9KL(OSJ) 7CJ(JPN) 6KK(JPN)	91-95 91-95	168 168	27 010 <b>(59,560)</b> 27 010 <b>(59,560)</b>	2.59 <b>(8'6")</b> 2.59 <b>(8'6")</b>	3.24 <b>(10'8")</b> 3.24 <b>(10'8")</b>	10.27 <b>(33'8")</b> 10.27 <b>(33'8")</b>	3.39 <b>(11'1")</b> 3.39 <b>(11'1")</b>	11.50 <b>(37'7")</b> 11.50 <b>(37'7")</b>	11 650 <b>(25,150)</b> 11 650 <b>(25,150)</b>
325B L	6DN(GOS)	96-01	168	28 890 <b>(63,690)</b>	2.59 <b>(8'6")</b>	3.21 <b>(10'6")</b>	10.35 <b>(33'11")</b>	3.39 <b>(11'1")</b>	10.57 <b>(34'8")</b>	15 460 <b>(34,080)</b>
325B LN	8FN(GOS)	96-01	168	27 670 <b>(61,000)</b>	2.39 <b>(7'10")</b>	3.21 <b>(10'6")</b>	10.35 <b>(33'11")</b>	2.99 <b>(9'10")</b>	10.57 <b>(34'8")</b>	15 030 <b>(33,140)</b>
325C L	CBR CSJ	01-06	188	28 600 <b>(63,100)</b>	2.59 <b>(8'6")</b>	3.26 <b>(10'8")</b>	10.34 <b>(33'11")</b>	3.39 <b>(11'1")</b>	10.51 <b>(34'6")</b>	15 600 <b>(33,750)</b>
325D L	A3R	06-08	204	29 240 <b>(64,460)</b>	2.59 <b>(8'6")</b>	3.04 <b>(10'0")</b>	10.42 <b>(34'2")</b>	3.39 <b>(11'1")</b>	11.15 <b>(36'7")</b>	15 450 <b>(33,400)</b>
330*	9PJ(OSJ) 8RL(OSJ) 9NG(JPN) 9PJ(JPN)	92-95 92-95	222 222	32 130 <b>(70,830)</b> 32 130 <b>(70,830)</b>	2.59 <b>(8'6")</b> 2.59 <b>(8'6")</b>	3.29 <b>(10'10")</b> 3.29 <b>(10'10")</b>	11.01 <b>(36'2")</b> 11.01 <b>(36'2")</b>	3.19 <b>(10'6")</b> 3.19 <b>(10'6")</b>	12.37 <b>(40'6")</b> 12.37 <b>(40'6")</b>	15 550 <b>(33,650)</b> 15 550 <b>(33,650)</b>
330 L*	6SK(OSJ) 9ML(OSJ) 6WJ(JPN) 6SK(JPN)	92-95 92-95	222 222	33 510 <b>(73,880)</b> 33 510 <b>(70,830)</b>	2.59 <b>(8'6")</b> 2.59 <b>(8'6")</b>	3.29 <b>(10'10")</b> 3.29 <b>(10'10")</b>	11.01 <b>(36'2")</b> 11.01 <b>(36'2")</b>	3.34 <b>(10'11")</b> 3.34 <b>(10'11")</b>	12.37 <b>(40'6")</b> 12.37 <b>(40'6")</b>	14 600 <b>(31,500)</b> 14 600 <b>(31,500)</b>
330B L	3YR(GOS)	96-01	222	34 020 <b>(75,000)</b>	2.59 <b>(8'6")</b>	3.56 <b>(11'8")</b>	11.06 <b>(36'3")</b>	3.34 <b>(10'11")</b>	11.62 <b>(38'1")</b>	17 070 <b>(37,630)</b>
330B LN	5LR(GOS)	96-01	222	33 860 <b>(74,650)</b>	2.39 <b>(7'10")</b>	3.56 <b>(11'8")</b>	11.06 <b>(36'3")</b>	2.99 <b>(9'10")</b>	11.62 <b>(38'1")</b>	17 070 <b>(37,630)</b>
330C L	CAP CGZ	01-06	247	35 100 <b>(77,400)</b>	2.59 <b>(8'6")</b>	3.63 <b>(11'11")</b>	11.19 <b>(36'9")</b>	3.44 <b>(11'3")</b>	11.64 <b>(38'2")</b>	17 450 <b>(37,750)</b>
330D L	MWP	06-08	268	36 150 <b>(79,700)</b>	2.59 <b>(8'6")</b>	3.14 <b>(10'4")</b>	11.20 <b>(36'9")</b>	3.44 <b>(11'3")</b>	11.71 <b>(38'5")</b>	17 610 <b>(38,100)</b>

\*When shipped with medium stick and bucket curled under.

\*\*Maximum reach at ground level, one-piece boom, longest stick.

\*\*\*Lift capacity at 4.6 m (15'0") over front, one-piece boom, longest stick (6.1 m (20'0") over front for 375/375 L).

Hydraulic Excavators (Track) (cont'd)

Model	Product Ident. No. Prefix COSA (US)	Years Built	Flywheel Horsepower	Approx. Operating Weight kg (lb)	Track Gauge m (ft)	Height* m (ft)	Length* m (ft)	Width m (ft)	Max. Reach** m (ft)	Lift Capacity*** kg (lb)
345B	4SS	97-00	290	44 050 <b>(97,100)</b>	2.74 <b>(9'0")</b>	3.76 <b>(12'4")</b>	11.79 <b>(33'8")</b>	3.49 <b>(11'5")</b>	13.0 <b>(42'8")</b>	20 850 <b>(45,000)</b>
345B L	7KS(GOS) 2SW(GOS)	98-00	290	47 665 <b>(105,080)</b>	2.39 <b>(7'10")</b>	3.68 <b>(12'1")</b>	11.74 <b>(38'6")</b>	2.99 <b>(9'10")</b>	12.97 <b>(42'6")</b>	21 000 <b>(46,300)</b>
345B L Series II	CCC(VG) FEE(FG) DET(MH)	01-05	321	48 960 <b>(107,960)</b>	2.39 <b>(7'10")</b>	3.87 <b>(12'8")</b>	11.46 <b>(37'7")</b>	2.99 <b>(9'10")</b>	11.69 <b>(38'4")</b>	19 250 <b>(42,450)</b>
345C L Tier 2	ELS(FG) GCL(VG)	05-08	325	50 500 <b>(111,350)</b>	2.39 <b>(7'10")</b>	3.74 <b>(12'3")</b>	11.84 <b>(38'10")</b>	2.99 <b>(9'10")</b>	11.70 <b>(38'5")</b>	20 100 <b>(44,320)</b>
345C L Tier 3	LYS(FG) GPH(VG) FPC(VG)	05-08	325	50 500 <b>(111,350)</b>	2.39 <b>(7'10")</b>	3.74 <b>(12'3")</b>	11.84 <b>(38'10")</b>	2.99 <b>(9'10")</b>	11.70 <b>(38'5")</b>	20 100 <b>(44,320)</b>
350	7RK	93-99	286	48 040 <b>(105,910)</b>	2.55 <b>(8'4.4")</b>	3.75 <b>(12'3.6")</b>	12.2 <b>(40'3")</b>	3.2 <b>(10'6")</b>	13.45 <b>(44'1.5")</b>	17 750 <b>(39,100)</b>
	2ZL	93-99	286	50 094 <b>(110,210)</b>	2.55 <b>(8'4.4")</b>	3.75 <b>(12'4")</b>	12.2 <b>(40'0")</b>	3.3 <b>(10'10")</b>	13.49 <b>(44'3")</b>	17 750 <b>(39,100)</b>
350 L	9DK	93-99	286	49 010 <b>(108,050)</b>	2.55 <b>(8'4.4")</b>	3.75 <b>(12'3.6")</b>	12.2 <b>(40'3")</b>	3.3 <b>(10'9.9")</b>	13.45 <b>(44'1.5")</b>	17 750 <b>(39,100)</b>
	3ML	93-99	286	51 126 <b>(112,450)</b>	2.55 <b>(8'4.4")</b>	3.75 <b>(12'4")</b>	12.2 <b>(40'0")</b>	3.3 <b>(10'10")</b>	13.49 <b>(44'3")</b>	17 600 <b>(40,900)</b>
365B L	9PZ(GOS)	99-02	385	66 245 <b>(146,050)</b>	2.75 <b>(9'0")</b>	4.57 <b>(15'0")</b>	12.17 <b>(39'11")</b>	3.50 <b>(11'6")</b>	14.04 <b>(46'1")</b>	29 200 <b>(64,370)</b>
365B L Series II	JMB(EAME) DER(NACD) PEG(FS) SDL(MH)	02-04	404	70 250 <b>(154,900)</b>	2.75 <b>(9'0")</b>	4.7 <b>(15'5")</b>	12.54 <b>(41'2")</b>	3.42 <b>(11'3")</b>	14.09 <b>(16'3")</b>	13 040 <b>(28,750)</b>
375	8WJ	92-01	428	81 190 <b>(178,800)</b>	2.75 <b>(9'0")</b>	5.24 <b>(17'2")</b>	14.3 <b>(46'11")</b>	3.5 <b>(11'6")</b>	15.96 <b>(52'4")</b>	30 300 <b>(65,600)</b>
	6NK(GOS)	92-02	428	79 807 <b>(175,940)</b>	2.75 <b>(9'0")</b>	5.24 <b>(17'2")</b>	13.14 <b>(43'1")</b>	3.48 <b>(11'5")</b>	15.67 <b>(51'5")</b>	23 620 <b>(52,070)</b>
375 L	1JM	93-01	428	82 380 <b>(181,500)</b>	2.94 <b>(9'7")</b>	5.24 <b>(17'2")</b>	14.3 <b>(46'11")</b>	3.84 <b>(12'7")</b>	15.96 <b>(52'4")</b>	29 550 <b>(64,400)</b>
	9WL(GOS)	92-02	428	80 700 <b>(177,910)</b>	2.75 <b>(9'0")</b>	5.24 <b>(17'2")</b>	14.29 <b>(46'11")</b>	3.48 <b>(11'5")</b>	15.67 <b>(51'5")</b>	23 620 <b>(52,070)</b>
385B L	FDL(EAME) RCD(NACD) CLS(EAME) MYA(NACD)	01-04	513	89 130 <b>(196,530)</b>	2.75 <b>(9'0")</b>	5.16 <b>(16'11")</b>	14.6 <b>(47'11")</b>	3.73 <b>(12'3")</b>	15.61 <b>(51'2")</b>	13 810 <b>(30,450)</b>
5090B	CLD EAME SJY NACD	01-04	512	87 500 <b>(192,937)</b>	3.5 <b>(11.51)</b>	4.63 <b>(15.19)</b>	14.26 <b>(46.77)</b>	3.47 <b>(11.38)</b>	10.35 <b>(33.95)</b>	— —

\*When shipped with medium stick and bucket curled under.

\*\*Maximum reach at ground level, one-piece boom, longest stick.

\*\*\*Lift capacity at 4.6 m (15'0") over front, one-piece boom, longest stick (6.1 m (20'0") over front for 375/375 L).



## HYDRAULIC EXCAVATORS (Wheel)

Model	Product Ident. No. Prefix (USA)	Years Built	Flywheel Horsepower	Approx. Operating Weight kg (lb)	Height* m (ft)	Length* m (ft)	Width m (ft)	Max. Reach** m (ft)	Lift Capacity*** kg (lb)	Standard Tire Size
206	(2RC) (3GC)	84-89	Deutz-67 Perkins-71	12 185 (26,863)	3.11 (10'2")	7.38 (24'2.5")	2.40 (7'10")	8.14 (26'9")	3360 (7400)	Dual 9.00-20 12PR
212	(3JC) (5DC)	84-89	Deutz-84 Perkins-94	13 700 (30,423)	3.15 (10'4")	8.00 (26'3")	2.49 (8'2")	9.86 (32'4")	3850 (8490)	Dual 10.00-20 12PR
212B	(3PJ)	90-95	110	14 000 (30,870)	3.04 (10'0")	8.28 (27'2")	2.49 (8'2")	9.48 (31'1")	3900 (8600)	Dual 10.00-20 12PR
214	(9MB) (1KB)	84-89	Deutz-101 Perkins-102	15 600 (34,175)	3.06 (10'0")	8.28 (27'2")	2.49 (8'2")			Dual 10.00-20 12PR
214B	4CF	87-94	110	18 700 (41,230)	3.06 (10'0")	8.28 (27'2")	2.49 (8'2")	10.41 (34'2")	4200 (9260)	Dual 10.00-20 12PR
214B FT	9NF	87-94	135	18 700 (41,230)	3.06 (10'0")	8.28 (27'2")	2.49 (8'2")	10.41 (34'2")	4200 (9260)	Dual 10.00-20 12PR
224	(2JC) (5TC)	84-89	Deutz-143 Perkins-124	19 000 (41,890)	3.42 (11'3")	8.98 (29'6")	2.49 (8'2")	10.61 (34'10")	4800 (10,600)	Dual 10.00-20 12PR

\*When shipped with medium stick and bucket curled under.

\*\*Maximum reach at ground level, one-piece boom, longest stick.

\*\*\*Lift capacity at 4.6 m (15'0") over front, one-piece boom, longest stick.

Model	Product Ident. No. Prefix (USA)	Years Built	Flywheel Horsepower	Approx. Operating Weight kg (lb)	Height* m (ft)	Length* m (ft)	Width m (ft)	Max. Reach** m (ft)	Lift Capacity*** kg (lb)	Standard Tire Size
M312	6TL	96-02	114	13 425 (29,602)	3.07 (10'1")	8.62 (28'3")	2.5 (8'2")	8.9 (29'2")	4300 (9482)	10-20.00 14PR
M315	7ML	95-02	117	15 570 (34,332)	3.08 (10'1")	8.84 (29'0")	2.5 (8'2")	9.26 (30'5")	5100 (11,246)	10-20.00 14PR
M318	8AL	95-02	131	17 870 (39,403)	3.1 (10'2")	8.97 (29'5")	2.6 (8'6")	10.55 (34'7")	6400 (14,112)	10-20.00 14PR
M318 MH	6ES	98-02	133	20 300 (44,762)	3.37 (11'1")	8.89 (29'2")	2.69 (8'10")	10.5 (34'5")	4600 (10,143)	11-20.00
	8SS	98-02	133	20 300 (44,762)	3.37 (11'1")	8.89 (29'2")	2.69 (8'10")	10.5 (34'5")	4600 (10,143)	11-20.00
M320	6WL	97-02	131	20 200 (44,541)	3.21 (10'6")	9.55 (31'4")	2.75 (9'0")	11.18 (36'8")	7500 (16,538)	11-20.00 14PR
M320 MH	9PS	98-02	133	22 300 (49,172)	3.35 (11'0")	9.92 (32'7")	2.69 (8'10")	11.6 (38'1")	6600 (14,553)	11-20.00

\*When shipped with medium stick and bucket curled under, one-piece boom.

\*\*Maximum reach at ground level, one-piece boom, longest stick.

\*\*\*Lift capacity at 4.6 m (15'0") over front, rear dozer up, one-piece boom, longest stick.

## Hydraulic Excavators (Wheel) (cont'd)

Model	Product Ident. No. Prefix (USA)	Years Built	Flywheel Horsepower	Approx. Operating Weight kg (lb)	Height* m (ft)	Length* m (ft)	Width m (ft)	Max. Reach** m (ft)	Lift Capacity*** kg (lb)	Standard Tire Size
M313C	H2A BDR	05-06 02-05	118	13 100-14 750 <b>(28,886-35,524)</b>	3.12 <b>(10'2")</b>	8.08 <b>(26'6")</b>	2.55 <b>(8'4")</b>	8.77 <b>(28'9")</b>	4800 <b>(10,584)</b>	10.00-20 16PR
M315C	H2B BDM	05-06 02-05	129	15 000-16 650 <b>(33,075-36,713)</b>	3.15 <b>(10'4")</b>	8.33 <b>(27'4")</b>	2.55 <b>(8'4")</b>	9.17 <b>(30'1")</b>	5600 <b>(12,348)</b>	10.00-20 16PR
M316C	H2C BDX	05-06 02-05	138	16 300-18 200 <b>(35,942-40,131)</b>	3.17 <b>(10'5")</b>	8.40 <b>(27'7")</b>	2.55 <b>(8'4")</b>	9.17 <b>(30'1")</b>	6500 <b>(14,330)</b>	10.00-20 16PR
M318C	H2D BCZ	05-06 02-05	151	17 800-19 700 <b>(39,249-43,439)</b>	3.21 <b>(10'6")</b>	8.96 <b>(29'5")</b>	2.55 <b>(8'4")</b>	9.60 <b>(31'6")</b>	6600 <b>(14,550)</b>	10.00-20 16PR
M322C	H2E BDK	05-06 02-05	164	20 500-22 700 <b>(45,203-50,054)</b>	3.25 <b>(10'8")</b>	9.64 <b>(31'7")</b>	2.75 <b>(9'0")</b>	10.32 <b>(33'10")</b>	7300 <b>(16,093)</b>	11.00-20 16PR
M318C MH	H2F BEB	05-06 02-05	151	21 460 <b>(47,319)</b>	3.48 <b>(11'5")</b>	9.06 <b>(29'9")</b>	2.99 <b>(9'10")</b>	11.00 <b>(36'1")</b>	6800 <b>(14,991)</b>	10.00-20 16PR
M322C MH	H2G BDY	05-06 02-05	164	24 690 <b>(54,441)</b>	3.49 <b>(11'5")</b>	9.88 <b>(32'5")</b>	2.99 <b>(9'10")</b>	12.50 <b>(36'11")</b>	8700 <b>(19,180)</b>	11.00-20 16PR

\*When shipped with medium stick and bucket curled under, one-piece boom.

\*\*Maximum reach at ground level, one-piece boom, longest stick.

\*\*\*Lift capacity at 4.6 m (15'0") over front, rear dozer up, one-piece boom, longest stick.



## 5000 SERIES EXCAVATORS AND FRONT SHOVELS

Model	Product Ident. No. Prefix COSA (US)	Years Built	Flywheel Horsepower	Approx. Operating Weight kg (lb)	Track Gauge	Height*	Length*	Width	Max. Reach**	Lift Capacity***
					m (ft)	m (ft)	m (ft)	m (ft)	m (ft)	kg (lb)
5080	6XK(GOS)	94-02	428	83 800 (184,750)	2.75 (9'0")	4.73 (15'6")	13.76 (45'2")	3.48 (11'5")	9.76 (32'0")	—
5090B	CLD(EAME) SJY(NACD)	01-04	512	87 500 (192,940)	3.51 (11'6")	4.63 (15'2")	14.26 (46'9")	3.47 (11'5")	10.35 (33'11")	—

\*When shipped with medium stick and bucket curled under.

\*\*Maximum reach at ground level, one-piece boom, longest stick.

\*\*\*Lift capacity at 4.6 m (15'0") over front, one-piece boom, longest stick.

Model	Product Ident. No. Prefix (USA)	Years Built	Flywheel Horsepower	Approx. Operating Weight kg (lb)	Rated*	Breakout	Crowd	Track Gauge	Max. Reach*	Max. Load Height	Max. Digging Depth
					Capacity m <sup>3</sup> (yd <sup>3</sup> )	Force kN (lb)	Force kN (lb)	m (ft)	m (ft)	m (ft)	m (ft)
5110B ME	AAA	00-03	696	127 000 (280,000)	7.6 (9.9)	501 (112,600)	439 (98,800)	4.1 (13.4')	13.9 (45.7')	8.6 (28.0')	7.9 (25.9')
5110B L	AAK	02-03	696	129 000 (284,000)	4.6 (6.0)	463 (104,175)	377 (84,825)	4.1 (13.4')	16.39 (53.8')	10.06 (33.0')	10.51 (34.5')
5130 ME	5ZL	92-97	755	180 000 (397,000)	10.0 (13.0)	615 (138,400)	624 (140,300)	4.72 (15'6")	14.9 (48'11")	9.1 (29'10")	8.4 (27'7")
5130 FS	5ZL	92-97	755	179 000 (395,000)	10.5 (13.7)	715 (161,000)	770 (173,000)	4.72 (15'6")	12.4 (40'8")	9.1 (29'10")	—
5130B ME	4CS	97-03	800	182 000 (401,000)	10.5 (13.7)	672 (151,100)	624 (140,300)	4.72 (15.5')	14.9 (48.9')	9.1 (29.8')	8.4 (27.6')
5130B FS	4CS	97-03	800	181 000 (399,000)	11.0 (14.5)	715 (161,000)	770 (173,000)	4.72 (15.5')	12.4 (40.7')	9.1 (29.8')	—
5230 ME	7LL	94-00	1470	316 600 (698,000)	16.0 (21.0)	873 (196,260)	874 (196,480)	5.2 (17'0")	17.7 (58'0")	9.8 (32'2")	9.4 (30'10")
5230 FS	7LL	94-00	1470	318 422 (702,000)	17.0 (22.2)	1125 (253,000)	1250 (281,000)	5.2 (17'0")	14.8 (48'7")	10.3 (33'10")	—
5230B ME	4HZ	01-04	1550	328 100 (723,400)	16.0 (21.0)	855 (192,083)	885 (198,848)	5.196 (17.0')	17.8 (58.4')	9.8 (32.0')	9.5 (31.3')
5230B FS	4HZ	01-04	1550	327 000 (721,000)	17.0 (22.2)	1162 (261,145)	1145 (257,324)	5.196 (17.0')	14.9 (48.8')	10.4 (34.1')	—

\*Standard boom and stick.





## LOGGING AND FOREST PRODUCT MACHINES

Model	Product Ident. No. Prefix	Years Built	Flywheel Power kW (hp)	Overall Track Length m (ft)	Overall Length m (ft)	Overall Width m (ft)	Operating Weight kg (lb)
320B Stroke Delimber			96 (128)		11.96 (39'3")	3.66 (12'0")	30 390 (67,000)
FB221	8XD	1986	147 (197)	4.47 (14'8")	9.78 (32'1")	3.20 (10'6")	28 180 (62,000)
FB227	10W	1983-93	100/134 (135/180)	4.55 (14'11")	11.88 (39'0")	3.35 (11'0")	31 769 (69,892)
DL221	8YD	1987	98 (132)	4.47 (14'8")	—	—	22 816 (50,300)
LL216	8JD	1986	95 (128)	—	10.70 to 11.23 (35'1" to 36'10")	2.64 (8'8")	17 577 (38,750)
LL228	8MD	1986	131 (176)	—	9.7 to 11.6 (32'0" to 38'0")	2.62 (8'7")	30 391 (67,000)
LL231	8PD	1986	175 (235)	5.03 (16'6")	10.6 to 11.6 (35'0" to 38'0")	3.56 (11'8")	39 146 (86,300)
320B LL	6LS/9JS	96-01	96 (128)	4.48 (14'8")	—	3.29 (10'10")	28 610 (63,100)
322B LL	1YS	96-02	114 (153)	4.66 (15'3")	—	3.72 (12'3")	32 970 (72,686)
322C FM GF (HD/LC)	—	01-06	125 (168)	4.66 (15'4")	9.96 (32'8")	3.29 (10'10")	28 229 (62,245)*
322C FM GF (HW)	—	01-06	125 (168)	4.69 (15'5")	9.91 (32'6")	3.62 (11'11")	30 710 (67,716)*
322C FM LL (U/U)	—	01-06	125 (168)	4.69 (15'5")	14.10 (46'3")	3.62 (11'11")	33 607 (74,103)*
322C FM LL (O/U)	—	01-06	125 (168)	4.69 (15'5")	15 (49'3")	3.62 (11'11")	33 896 (74,741)*
325B LL	2JR	96-01	124 (166)	4.66 (15'3")	—	3.62 (11'11")	36 916 (81,400)
325C FM GF (HD/LC)	—	02-06	140 (188)	4.70 (15'5")	10.34 (33'11")	3.44 (11'3")	31 942 (70,432)*
325C FM GF (HW)	—	02-06	140 (188)	4.70 (15'5")	10.29 (33'9")	3.62 (11'11")	33 078 (72,937)*
325C FM LL (U/U)	—	02-06	140 (188)	4.70 (15'5")	14.87 (48'9")	3.62 (11'11")	37 644 (83,005)*
325C FM LL (O/U)	—	02-06	140 (188)	4.70 (15'5")	15.75 (51'8")	3.62 (11'11")	38 219 (84,273)*
330B LL	6DR	96-02	160 (214)	5.02 (16'6")	—	3.62 (11'11")	44 172 (97,400)
330C FM GF (HD/LC)	—	02-06	184 (247)	5.08 (16'8")	11.19 (36'9")	3.52 (11'6")	39 347 (86,760)*
330C FM GF (HW)	—	02-06	184 (247)	5.07 (16'7")	11.19 (36'9")	3.62 (11'11")	40 778 (89,915)*
330C FM LL (U/U)	—	02-06	184 (247)	5.07 (16'7")	16.67 (54'8")	3.62 (11'11")	44 430 (97,968)*
330C FM LL (O/U)	—	02-06	184 (247)	5.07 (16'7")	17.36 (57'0")	3.62 (11'11")	44 965 (99,148)*

\*Operating Weight without bucket or grapple and with the new FM Cab/Riser with integrated guarding (available in July 2004).



## WHEEL SKIDDERS

Model	Product Ident. No. Prefix	Years Built	Flywheel Horsepower kW (hp)	Operating Weight kg (lb)	Ground Clearance mm (in)	Wheel Base m (ft/in)
508 Cable	9NC	87-89	71 (95)	7770 (17,130)	521 (20.5")	2.8 (9'2")
508 Grapple	2HD	87-89	71 (95)	8766 (19,308)	521 (20.5")	2.8 (9'2")
518 FB	8ZC	86-89	96 (130)	11 612 (25,600)	587 (23.1")	3.25 (10'8")
518 PS Cable	50S	71-83	90 (120)	7718 (17,000)	505.4 (19.8976")	2895.6 (9'6")
518 PS Grapple	55U	1-80/81-83	90/97 (120/130)	9307 (20,500)	505.4 (19.8976")	2895.6 (9'6")
518 Cable	94U	3-84/85-92	90/97 (120/130)	9988 (22,000)	470 (18.5039")	3251 (10'8.4")
518 Grapple	95U	81-90	97 (130)	11 259 (24,800)	470 (18.5039")	3251 (10'8.4")
518 Series II Cable	94U	91-92	dual 97/108 dual (130/145)	10 260 (22,600)	470 (18.5039")	3251 (10'8.4")
518 Series II Grapple	95U	91-92	dual 97/108 dual (130/145)	12 031 (26,500)	470 (18.5039")	3251 (10'8.4")
518C Cable	1CL	93-95	115 (154)	11 528 (25,391)	450.7 (17.74406")	3251 (10'8.4")
518C Grapple	9HJ	93-95	115 (154)	12 587 (27,725)	463.4 (18.24406")	3251 (10'8.4")
525	—	—	119 (160)	13 558 (29,891)	527 (20.7)	3.5 (11.5)
525B	—	02-06	119 (160)	18 325 (40,400)	463 (18.2)	3.5 (11.5)
535B	—	6-Feb	134 (180)	19 006 (41,900)	463 (18.2)	3.5 (11.5)
545 Grapple	—	6-Feb	149.1 (225)	20 230 (44,600)	606.4 (23.9)	3.8 (12.5)



**TRACK SKIDDERS**

Model	Product Ident. No. Prefix	Years Built	Flywheel Horsepower kW (hp)	Operating Weight kg (lb)	Gauge m (ft/in)
D4 TSK Series II	8ZF	90-92	78 <b>(105)</b>	12 909 <b>(28,400)</b>	2.00 <b>(6'6")</b>
D4 TSK Series III	7PK	92-96	78 <b>(105)</b>	14 000 <b>(30,900)</b>	2.00 <b>(6'6")</b>
D5H TSK Series II	7EG	92-96	97 <b>(130)</b>	18 800 <b>(41,360)</b>	2.16 <b>(7'11")</b>



**BACKHOE LOADERS**

Model	Product Ident. No. Prefix	Years Built	Flywheel Horsepower kW (hp)	Operating Weight kg (lb)	Digging Depth mm (ft/in)	GP Bucket Capacity m³ (yd³)	MP Bucket Capacity m³ (yd³)
416	5PC	85-90	46 <b>(62)</b>	6156 <b>(13,574)</b>	4420 <b>(14'6")</b>	0.76 <b>(1.0)</b>	0.76 <b>(1.0)</b>
416 Series II	5PC	90-92	46 <b>(62)</b>	6217 <b>(13,708)</b>	4420 <b>(14'6")</b>	0.76 <b>(1.0)</b>	0.76 <b>(1.0)</b>
416B	8ZK(8SG)	92-95	59 <b>(79)</b>	6227 <b>(13,700)</b>	4420 <b>(14'6")</b>	0.76 <b>(1.0)</b>	0.96 <b>(1.25)</b>
416C	4ZN(5YN)	96-00	56 <b>(75)</b>	6330 <b>(13,957)</b>	4420 <b>(14'6")</b>	0.76 <b>(1.0)</b>	0.96 <b>(1.25)</b>
416C (IT)	1WR(1XR)	96-00	56 <b>(75)</b>	6666 <b>(14,698)</b>	4420 <b>(14'6")</b>	0.96 <b>(1.25)</b>	0.96 <b>(1.25)</b>
416D	BFP, BKG, BGJ, CXP	00-05	58 <b>(78)</b>	6900 <b>(15,257)</b>	4390 <b>(14'5")</b>	0.76 <b>(1.0)</b>	0.96 <b>(1.25)</b>
420D	FDP, BKC	00-05	69 <b>(93)</b>	7150 <b>(15,772)</b>	4390 <b>(14'5")</b>	0.96 <b>(1.25)</b>	0.96 <b>(1.25)</b>
420D (IT)	BLN, BMC, MBH	00-05	69 <b>(93)</b>	7150 <b>(15,772)</b>	4390 <b>(14'5")</b>	0.96 <b>(1.25)</b>	0.96 <b>(1.25)</b>
424D	RXA, CJZ	01-05	56 <b>(75)</b>	7502 <b>(16,539)</b>	4854 <b>(15'9")</b>	1.0 <b>(1.31)</b>	0.96 <b>(1.25)</b>
426	7BC	86-90	52 <b>(70)</b>	6549 <b>(14,626)</b>	4720 <b>(15'6")</b>	0.96 <b>(1.25)</b>	0.76 <b>(1.0)</b>
426 Series II	7BC	90-92	52 <b>(70)</b>	7315 <b>(15,126)</b>	4720 <b>(15'6")</b>	0.96 <b>(1.25)</b>	0.76 <b>(1.0)</b>
426B	6KL(5YJ)	92-95	59 <b>(79)</b>	6790 <b>(14,970)</b>	4720 <b>(15'6")</b>	0.96 <b>(1.25)</b>	0.96 <b>(1.25)</b>
426C	6XN(7WN)	96-98	60 <b>(80)</b>	7051 <b>(15,548)</b>	4721 <b>(15'6")</b>	0.96 <b>(1.25)</b>	0.96 <b>(1.25)</b>
426C	6XN3616 and up (7WN939 and up)	99-00	63 <b>(85)</b>	7051 <b>(15,548)</b>	4721 <b>(15'6")</b>	0.96 <b>(1.25)</b>	0.96 <b>(1.25)</b>

## Backhoe Loaders (cont'd)

Model	Product Ident. No. Prefix	Years Built	Flywheel Horsepower kW (hp)	Operating Weight kg (lb)	Digging Depth mm (ft/in)	GP Bucket Capacity m <sup>3</sup> (yd <sup>3</sup> )	MP Bucket Capacity m <sup>3</sup> (yd <sup>3</sup> )
(AWS) 426C	1CR(1ER)	96-98	60 <b>(80)</b>	7051 <b>(15,548)</b>	4721 <b>(15'6")</b>	0.96 <b>(1.25)</b>	0.96 <b>(1.25)</b>
(AWS) 426C	1CR864 and up (1ER864 and up)	99-00	63 <b>(85)</b>	7051 <b>(15,548)</b>	4721 <b>(15'6")</b>	0.96 <b>(1.25)</b>	0.96 <b>(1.25)</b>
426C (IT)	1YR(1ZR)	96-98	60 <b>(80)</b>	7387 <b>(16,289)</b>	4721 <b>(15'6")</b>	0.96 <b>(1.25)</b>	0.96 <b>(1.25)</b>
426C (IT)	1YR1517 and up (1ZR926 and up)	99-00	63 <b>(85)</b>	7387 <b>(16,289)</b>	4721 <b>(15'6")</b>	0.96 <b>(1.25)</b>	0.96 <b>(1.25)</b>
(AWS) 426C (IT)	1MR(1NR)	96-98	60 <b>(80)</b>	7387 <b>(16,289)</b>	4721 <b>(15'6")</b>	0.96 <b>(1.25)</b>	0.96 <b>(1.25)</b>
(AWS) 426C (IT)	1MR956 and up (1NR954 and up)	99-00	63 <b>(85)</b>	7387 <b>(16,289)</b>	4721 <b>(15'6")</b>	0.96 <b>(1.25)</b>	0.96 <b>(1.25)</b>
428	6TC	86-90	52 <b>(70)</b>	6963 <b>(15,350)</b>	4790 <b>(15'9")</b>	1.0 <b>(1.31)</b>	0.92 <b>(1.2)</b>
428 Series II	6TC	90-92	52 <b>(70)</b>	7143 <b>(15,750)</b>	4750 <b>(15'7")</b>	1.0 <b>(1.31)</b>	0.92 <b>(1.2)</b>
428B	7EJ	92-95	60 <b>(80)</b>	7254 <b>(15,992)</b>	4810 <b>(15'9")</b>	1.0 <b>(1.31)</b>	0.92 <b>(1.2)</b>
428C	8RN	96-00	56 <b>(75)</b>	7279 <b>(16,047)</b>	4811 <b>(15'9")</b>	1.0 <b>(1.31)</b>	1.03 <b>(1.35)</b>
428C (IT)	2CR	96-00	56 <b>(75)</b>	7615 <b>(16,788)</b>	4811 <b>(15'9")</b>	1.0 <b>(1.31)</b>	1.03 <b>(1.35)</b>
428D	DSX, BXC, MBM	01-05	61 <b>(82)</b>	7738 <b>(17,059)</b>	4854 <b>(15'9")</b>	1.0 <b>(1.31)</b>	1.03 <b>(1.35)</b>
430D	BNK	00-05	75 <b>(101)</b>	7355 <b>(16,217)</b>	4639 <b>(15'3")</b>	1.0 <b>(1.31)</b>	0.96 <b>(1.25)</b>
430D (IT)	BML	00-05	75 <b>(101)</b>	7355 <b>(16,217)</b>	4639 <b>(15'3")</b>	1.0 <b>(1.31)</b>	0.96 <b>(1.25)</b>
432D	TDR, WEP	01-05	69 <b>(93)</b>	7809 <b>(17,216)</b>	4854 <b>(15'9")</b>	1.0 <b>(1.31)</b>	1.03 <b>(1.35)</b>
436	5KF	88-90	57 <b>(77)</b>	6831 <b>(15,062)</b>	4960 <b>(16'3")</b>	0.76 <b>(1.0)</b>	0.76 <b>(1.0)</b>
436 Series II	5KF	90-92	57 <b>(77)</b>	6878 <b>(15,166)</b>	4950 <b>(16'3")</b>	0.76 <b>(1.0)</b>	0.76 <b>(1.0)</b>
436B	7FL(6MJ)	92-95	63 <b>(84)</b>	6857 <b>(15,086)</b>	4950 <b>(16'3")</b>	0.96 <b>(1.25)</b>	0.96 <b>(1.25)</b>
436C	8TN(9JN)	96-98	63 <b>(85)</b>	7118 <b>(15,694)</b>	4953 <b>(16'3")</b>	1.0 <b>(1.31)</b>	0.96 <b>(1.25)</b>
436C	8TN925 and up (9JN884 and up)	99-00	70 <b>(93)</b>	7118 <b>(15,694)</b>	4953 <b>(16'3")</b>	1.0 <b>(1.31)</b>	0.96 <b>(1.25)</b>
(AWS) 436C	1FR(1GR)	96-98	63 <b>(85)</b>	7118 <b>(15,694)</b>	4953 <b>(16'3")</b>	1.0 <b>(1.31)</b>	0.96 <b>(1.25)</b>
(AWS) 436C	1FR1416 and up (1GR916 and up)	99-00	70 <b>(93)</b>	7118 <b>(15,694)</b>	4953 <b>(16'3")</b>	1.0 <b>(1.31)</b>	0.96 <b>(1.25)</b>

## Backhoe Loaders (cont'd)

Model	Product Ident. No. Prefix	Years Built	Flywheel Horsepower kW (hp)	Operating Weight kg (lb)	Digging Depth mm (ft/in)	GP Bucket Capacity m <sup>3</sup> (yd <sup>3</sup> )	MP Bucket Capacity m <sup>3</sup> (yd <sup>3</sup> )
436C (IT)	2AR(2BR)	96-98	63 <b>(85)</b>	7454 <b>(16,435)</b>	4953 <b>(16'3")</b>	1.0 <b>(1.31)</b>	0.96 <b>(1.25)</b>
436C (IT)	2AR1604 and up (2BR911 and up)	99-00	70 <b>(93)</b>	7454 <b>(16,435)</b>	4953 <b>(16'3")</b>	1.0 <b>(1.31)</b>	0.96 <b>(1.25)</b>
(AWS) 436C (IT)	1PR(1RR)	96-98	63 <b>(85)</b>	7454 <b>(16,435)</b>	4953 <b>(16'3")</b>	1.0 <b>(1.31)</b>	0.96 <b>(1.25)</b>
(AWS) 436C (IT)	1PR1599 and up (1RR998 and up)	99-00	70 <b>(93)</b>	7454 <b>(16,435)</b>	4953 <b>(16'3")</b>	1.0 <b>(1.31)</b>	0.96 <b>(1.25)</b>
438	3DJ	88-90	63 <b>(84)</b>	7900 <b>(17,420)</b>	4810 <b>(15'9")</b>	1.0 <b>(1.31)</b>	0.92 <b>(1.2)</b>
438 Series II	3DJ	90-92	57 <b>(77)</b>	7364 <b>(16,237)</b>	4810 <b>(15'9")</b>	1.0 <b>(1.31)</b>	0.92 <b>(1.2)</b>
438B	3KK	92-95	62.7 <b>(84)</b>	8331 <b>(18,367)</b>	4870 <b>(16'0")</b>	1.0 <b>(1.31)</b>	0.92 <b>(1.2)</b>
438C	9KN	96-98	63 <b>(85)</b>	7384 <b>(16,279)</b>	4873 <b>(16'0")</b>	1.0 <b>(1.31)</b>	1.03 <b>(1.35)</b>
438C	9KN1061 and up	99-00	70 <b>(93)</b>	7384 <b>(16,279)</b>	4873 <b>(16'0")</b>	1.0 <b>(1.31)</b>	1.03 <b>(1.35)</b>
(AWS) 438C	1JR	96-98	63 <b>(85)</b>	7384 <b>(16,279)</b>	4873 <b>(16'0")</b>	1.0 <b>(1.31)</b>	1.03 <b>(1.35)</b>
(AWS) 438C	1JR1107 and up	99-00	70 <b>(93)</b>	7384 <b>(16,279)</b>	4873 <b>(16'0")</b>	1.0 <b>(1.31)</b>	1.03 <b>(1.35)</b>
438C (IT)	2DR	96-98	63 <b>(85)</b>	7720 <b>(17,020)</b>	4873 <b>(16'0")</b>	1.0 <b>(1.31)</b>	1.03 <b>(1.35)</b>
438C (IT)	2DR2717 and up	99-00	70 <b>(93)</b>	7720 <b>(17,020)</b>	4873 <b>(16'0")</b>	1.0 <b>(1.31)</b>	1.03 <b>(1.35)</b>
(AWS) 438C (IT)	1TR	96-98	63 <b>(85)</b>	7720 <b>(17,020)</b>	4873 <b>(16'0")</b>	1.0 <b>(1.31)</b>	1.03 <b>(1.35)</b>
(AWS) 438C (IT)	1TR1284 and up	99-00	70 <b>(93)</b>	7720 <b>(17,020)</b>	4873 <b>(16'0")</b>	1.0 <b>(1.31)</b>	1.03 <b>(1.35)</b>
442D	SMJ, TBD	01-05	75 <b>(101)</b>	7809 <b>(17,216)</b>	4854 <b>(15'9")</b>	1.0 <b>(1.31)</b>	1.03 <b>(1.35)</b>
446	6XF	89-95	71 <b>(95)</b>	8892 <b>(19,603)</b>	5220 <b>(17'2")</b>	1.15 <b>(1.5)</b>	1.10 <b>(1.5)</b>
446B			76 <b>(102)</b>	8890 <b>(19,600)</b>	5220 <b>(17'2")</b>	1.15 <b>(1.5)</b>	1.05 <b>(1.375)</b>
446D	DBL	04-06	76 <b>(102)</b>	8939 <b>(19,666)</b>	5142 <b>(16'10")</b>	1.15 <b>(1.5)</b>	1.25 <b>(1.63)</b>



**PIPELAYERS**

Model	Tractor Product Ident. No. Prefix	Years Built	Engine HP	Approx. Weight kg (lb)	Counterweight kg (lb)	Max. Lift Capacity 1.2 m (4'0") Overhang kg (lb)	Speed Range km/h (mph)		Ground Clearance mm (in)	Ground Contact m <sup>2</sup> (sq. in.)
							Forward	Reverse		
MD6	9U39C	52-57	93	12 375 <b>(27,820)</b>	1590 <b>(3500)</b>	12 035 <b>(26,530)</b>	2.7—10.6 <b>(1.7—6.6)</b>	3.2—10.0 <b>(2.0—6.2)</b>	321 <b>(13")</b>	1.77 <b>(2744)</b>
561B	62A	59-66	90	14 560 <b>(32,100)</b>	2270 <b>(5000)</b>	17 500 <b>(38,800)</b>	2.7—10.6 <b>(1.7—6.6)</b>	1.8—9.9 <b>(2.0—6.2)</b>	267 <b>(11")</b>	2.02 <b>(3130)</b>
561B	62A	66-67	93	14 350 <b>(31,637)</b>	2270 <b>(5000)</b>	17 600 <b>(38,800)</b>	2.7—10.9 <b>(1.7—6.8)</b>	3.4—10.3 <b>(2.1—6.4)</b>	267 <b>(11")</b>	2.02 <b>(3130)</b>
561C	85H	66-67	93	14 700 <b>(32,500)</b>	2450 <b>(5400)</b>	18 000 <b>(40,000)</b>	2.7—11.1 <b>(1.7—6.9)</b>	3.4—10.1 <b>(2.1—6.3)</b>	395 <b>(16")</b>	2.02 <b>(3130)</b>
561C	92J	67-77	105	14 700 <b>(32,500)</b>	2450 <b>(5400)</b>	18 100 <b>(40,000)</b>	2.7—11.1 <b>(1.7—6.9)</b>	3.4—10.1 <b>(2.1—6.3)</b>	395 <b>(16")</b>	2.02 <b>(3130)</b>
561D	54X	78-89	105	15 800 <b>(35,000)</b>	2990 <b>(6600)</b>	18 100 <b>(40,000)</b>	3.5—10.1 <b>(2.2—6.3)</b>	4.2—12.2 <b>(2.6—7.6)</b>	395 <b>(16")</b>	2.02 <b>(3130)</b>
561H	6NL	93-97	105	15 700 <b>(34,600)</b>	2128 <b>(4690)</b>	18 100 <b>(40,000)</b>	3.4—10.2 <b>(2.1—6.4)</b>	4.1—12.4 <b>(2.6—7.7)</b>	363 <b>(14.3")</b>	2.67 <b>(4120)</b>
561M		01	110	16 240 <b>(35,800)</b>	3260 <b>(7200)</b>	18 100 <b>(40,000)</b>	3.3—9.9 <b>(2.0—6.2)</b>	4.0—12.1 <b>(2.5—7.5)</b>	438 <b>(17.2")</b>	2.67 <b>(4120)</b>
561M CB* (US)	1KW	97-02	110	16 240 <b>(35,800)</b>						
561N	CPH	03-08	123	16 851 <b>(37,150)</b>	3270 <b>(7210)</b>	18 145 <b>(40,000)</b>	3.1—9.1 <b>(1.9—5.6)</b>	3.8—11.3 <b>(2.3—6.9)</b>	422 <b>(16.6")</b>	2.93 <b>(4542)</b>
561N	TAD	03-08	123	16 851 <b>(37,150)</b>	3270 <b>(7210)</b>	18 145 <b>(40,000)</b>	3.1—9.1 <b>(1.9—5.6)</b>	3.8—11.3 <b>(2.3—6.9)</b>	422 <b>(16.6")</b>	2.93 <b>(4542)</b>
571E PS	64A	61-67	160	22 680 <b>(50,000)</b>	2360 <b>(5200)</b>	7 490 <b>(60,600)</b>	3.7—10.3 <b>(2.3—6.4)</b>	4.3—12.1 <b>(2.7—7.5)</b>	400 <b>(16")</b>	3.04 <b>(4710)</b>
571E PS	64A	66-72	180	23 100 <b>(51,000)</b>	2360 <b>(5200)</b>	27 500 <b>(60,600)</b>	3.7—10.1 <b>(2.3—6.3)</b>	4.3—11.9 <b>(2.7—7.4)</b>	400 <b>(16")</b>	3.04 <b>(4710)</b>
571F	95N	72-74	180	22 800 <b>(50,300)</b>	4350 <b>(9600)</b>	27 500 <b>(60,600)</b>	3.5—9.7 <b>(2.2—6.0)</b>	4.2—11.4 <b>(2.6—7.1)</b>	400 <b>(16")</b>	3.04 <b>(4710)</b>
571G	16W 52D(JPN)	75-81 87-96	200 200	23 040 <b>(50,800)</b>	4350 <b>(9600)</b>	27 500 <b>(60,600)</b>	3.7—10.0 <b>(2.3—6.2)</b>	4.5—11.9 <b>(2.8—7.9)</b>	399 <b>(15.7")</b>	3.04 <b>(4710)</b>
MD7	17A	51-57	140	16 200 <b>(35,815)</b>	3400 <b>(7500)</b>	24 585 <b>(54,200)</b>	2.4—9.5 <b>(1.5—5.9)</b>	2.9—8.7 <b>(1.8—5.4)</b>	394 <b>(16")</b>	3.12 <b>(4840)</b>

\*Gauge 2.0 m (6'7"), Width 3.19 m (10'5"), Length 3.73 m (12'3"), Height 3.12 m (10'3"), PS Transmission.  
 Forward Speed: 1st gear 3.27 km/h (2.03 mph)  
 2nd gear 5.81 km/h (3.61 mph)  
 3rd gear 9.93 km/h (6.17 mph)

## Pipelayers (cont'd)

Model	Tractor Product Ident. No. Prefix	Years Built	Engine HP	Approx. Weight kg (lb)	Counterweight kg (lb)	Max. Lift Capacity 1.2 m (4'0") Overhang kg (lb)	Speed Range km/h (mph)		Ground Clearance mm (in)	Ground Contact m <sup>2</sup> (sq. in.)
							Forward	Reverse		
572C	21A	57-61	128	26 200 (57,820)	4720 (10,405)	39 000 (86,000)	3.2—7.7 (2.0—4.8)	3.9—6.1 (2.4—3.8)	483 (19")	3.30 (5109)
572D	21A	59	140	26 500 (58,520)	4940 (10,900)	39 000 (86,000)	4.2—9.7 (2.6—6.0)	4.8—7.7 (3.0—4.8)	483 (19")	3.30 (5109)
572E PS	65A	61-69	180	28 000 (62,000)	6000 (13,000)	40 800 (90,000)	3.7—10.1 (2.3—6.3)	4.3—11.9 (2.7—7.4)	480 (19")	3.45 (5345)
572F PS	96N	70-74	180	27 600 (61,000)	6440 (14,200)	40 800 (90,000)	3.5—9.7 (2.2—6.0)	4.2—11.4 (2.6—7.1)	480 (19")	3.45 (5345)
572G	40U	75-86	200	27 800 (61,300)	6400 (14,200)	40 800 (90,000)	3.7—10.0 (2.3—6.2)	4.5—11.9 (2.8—7.4)	480 (19")	3.45 5345
572G	8PC	84-89	200	27 800 (61,300)	6400 (14,200)	40 800 (90,000)	3.7—10.0 (2.3—6.2)	4.5—11.9 (2.8—7.4)	480 (19")	3.45 5345
572R	2HZ	98-04	230	30 110 (66,250)	5055 (11,150)	40 825 (90,000)	3.5—11.1 (2.3—6.9)	4.8—14.2 (3.0—8.8)	414 (16.3")	4.19 6500
578	8HB	89-97	300	46 580 (102,690)	11 777 (25,963)	70 307 (155,000)	3.8—10.8 (2.35—6.7)	4.7—13.8 (2.9—8.6)	452 (17.8")	5.17 (8020)
583C	16A	55-58	190	35 440 (78,132)	8470 (18,676)	58 970 (130,000)	3.9—8.7 (2.4—5.4)	3.9—8.7 (2.4—5.4)	533 (21")	4.24 (6580)
583H TC	38A	59-60	235	38 000 (83,840)	9030 (19,900)	62 140 (137,000)	4.5—10.3 (2.8—6.4)	4.5—10.3 (2.8—6.4)	537 (22")	4.66 (7220)
583H PS	61A	60-74	191	35 600 (78,500)	8470 (18,676)	58 970 (130,000)	3.9—8.7 (2.4—5.4)	3.9—8.7 (2.4—5.4)	533 (21")	4.55 (7050)
583H PS	61A	60-67	225	38 200 (84,270)	9000 (19,900)	62 140 (137,000)	4.1—11.1 (2.5—6.9)	4.6—12.8 (8.9—8.0)	537 (22")	4.66 (7220)
583H PS	61A	61	235	38 900 (85,720)	10 400 (22,880)	62 140 (137,000)	3.9—10.1 (2.4—6.3)	4.8—12.6 (3.0—7.8)	537 (22")	4.66 (7220)
583H	61A	74	270	40 600 (89,500)	10 300 (22,700)	63 500 (140,000)	3.9—10.5 (2.4—6.5)	4.8—13.0 (3.0—8.1)	533 (21")	4.65 (7220)
583K	78V	74-89	300	40 960 (90,300)	7840 (17,290)	63 500 (140,000)	4.0—10.9 (2.5—6.8)	5.0—13.5 (3.1—8.4)	530 (21")	4.65 (7220)
583R	2XS	98-05	228 kW (305)	44 748 (98,650)	9036 (19,920)	63 504 (140,000)	3.5—10.8 (2.3—6.8)	4.7—3.8 (2.9—8.6)	537 (21.1")	5.10 (7896)
589	31Z	82-06	313 kW (420)	65 366 (151,212)	11 854 (26,134)	104 330 (230,000)	3.5—10.9 (2.2—6.8)	4.3—13.7 (2.7—8.5)	625 (24.6")	6.96 (12,148)
594	62H	74	385	55 400 (122,000)	12 600 (27,800)	90 700 (200,000)	3.9—10.5 (2.4—6.5)	4.8—12.7 (3.0—7.9)	640 (25")	5.72 (8865)
594H	96V	74-82	410	56 065 (123,600)	12 555 (27,680)	90 700 (200,000)	4.0—10.8 (2.5—6.7)	5.0—13.2 (3.1—8.2)	630 (25")	6.48 (10,050)



## WHEEL TRACTOR-SCRAPERS

Model	Product Ident. No. Prefix	Years Built	Horse-power Max/ Rated	Capacity Struck/ Heaped m <sup>3</sup> (yd <sup>3</sup> )	Approx. Shipping Weight kg (lb)	Dimensions m (ft)				Tire Size (Standard) & ply rating Tractor & Scraper	Approx. % Weight on Drivers Loaded/ Empty	Turning Circle m (ft)
						Length	Width	Height	Width of Tread			
DW10 Tractor	1N	41-46	100/*	—	6550 (14,350)	4.57 (15'0")	2.24 (7'4")	1.93 (6'4")	1.73 (5'8")	10.0 × 20-12 18.0 × 24-16	—	—
DW10 Tractor	6V	46-47	100/*	—	6850 (15,100)	4.57 (15'0")	2.24 (7'4")	1.93 (6'4")	1.73 (5'8")	10.0 × 20-12 18.0 × 24-16	—	—
DW10 Tractor	1V	47-53	115/*	—	7540 (16,610)	4.70 (15'5")	2.34 (7'8")	1.93 (6'4")	1.79 (5'10")	12.0 × 20-14 21.0 × 25-20	—	—
DW10 & No. 10 Scraper	1V 3C	47-51	115/*	6.7/8.4 (8.7/11)	15 980 (35,240)	11.23 (37'0")	3.02 (9'11")	2.69 (8'10")	1.88 (6'2")	12.0 × 20-14 21.0 × 25-20	39/44	7.92 (26'0")
DW10 & No. 10 Scraper	1V 19C	52-53	115/*	5.3/6.9 (7/9)	15 130 (33,365)	10.72 (35'2")	2.87 (9'5")	2.36 (7'9")	1.80 (5'11")	12.0 × 20-14 21.0 × 25-20 16.0 × 21-20 Scraper	42/46	11.23 (37'0")
DW15 & No. 10 Scraper	45C 19C	54-55	/150	5.3/6.9 (7/9)	15 960 (35,180)	11.10 (36'5")	2.87 (9'5")	2.36 (7'9")	1.80 (5'11")	12.0 × 20-14 21.0 × 25-20 16.0 × 21-20 Scraper	42/46	10.36 (34'0")
DW15 & No. 15 Scraper	45C 4W	54-55	/150	7.7/9.2 (10/12)	9400 (20,720)	11.84 (38'10")	3.18 (10'5")	2.69 (8'10")	1.93 (6'4")	12.0 × 20-14 21.0 × 25-20	40/42	11.23 (37'0")
DW15 Tractor	45C	54-55	/150	—	9510 (20,960)	5.08 (16'8")	2.39 (7'10")	2.69 (8'10")	1.98 (6'6")	12.0 × 20-14 21.0 × 25-20	—	—
DW15C & No. 15 Scraper	59C or 70C	55-57	186/*	7.7/9.5 (10/12.5)	19 220 (42,370)	11.84 (38'10")	3.18 (10'5")	2.69 (8'10")	1.98 (6'6")	12.0 × 12-14 21.0 × 25-20	40/42	10.36 (34'0")
DW15E & No. 428 Scraper	75D or 76D	57-59	200/172	10/14 (13/18)	20 280 (44,711)	12.22 (40'1")	3.30 (10'10")	3.05 (10'0")	1.98 (6'6")	12.0 × 20-14 26.5 × 25-20	37/41	—
DW15F & No. 428 Scraper	75D or 76D	58-59	200/172	10/14 (13/18)	20 280 (44,711)	12.22 (40'1")	3.30 (10'10")	3.05 (10'0")	1.98 (6'6")	12.0 × 20-14 26.5 × 25-20	37/41	—
DW20 & No. 20 Scraper	21C 11C	51-55	225/*	14/7.6 (18/23)	12 750 (28,100)	13.23 (43'5")	3.53 (11'7")	3.10 (10'2")	2.29 (7'6")	24.0 × 29-4	37/41	11.23 (37'0")
DW20 Tractor (For W20 Wagon)	6W	51-55	225/*	—	11 620 (25,610)	5.39 (17'8")	2.79 (9'2")	2.41 (7'11")	2.18 (7'2")	14.0 × 24-16 24.0 × 29-24	—	—
DW20E & No. 456 Scraper	57C 67C	55-57	300/*	14/19 (18/25)	26 040 (57,400)	13.36 (43'10")	3.58 (11'9")	3.45 (11'4")	2.24 (7'4")	14.0 × 24-16 29.5 × 29-22	34/42	11.58 (38'0")
DW20F & No. 456 Scraper	87E 88E	58-60	320/*	14/19 (18/25)	26 870 (59,240)	13.36 (43'10")	3.58 (11'9")	3.45 (11'4")	2.24 (7'4")	14.0 × 24-16 29.5 × 29-22	38/42	11.58 (38'0")
DW20G & No. 456 Scraper	87E 88E	58-60	345/*	15/21 (19.5/27)	27 200 (59,960)	13.36 (43'10")	3.58 (11'9")	3.45 (11'4")	2.24 (7'4")	14.0 × 24-16 29.5 × 29-28	38/42	11.58 (38'0")
DW20G & No. 482 Scraper	87E 88E	58-60	345/*	18.5/26 (24/34)	31 070 (68,500)	14.05 (46'1")	3.91 (12'10")	3.81 (12'6")	2.39 (7'10")	14.0 × 24-16 29.5 × 29-28	37/40	11.58 (38'0")

\*Maximum HP only available.



## Wheel Tractor-Scrapers (cont'd)

Model	Product Ident. No. Prefix	Years Built	Horsepower Max/ Rated	Capacity Struck/ Heaped m <sup>3</sup> (yd <sup>3</sup> )	Approx. Shipping Weight kg (lb)	Dimensions m (ft)				Tire Size (Standard) & ply rating Tractor & Scraper	Approx. % Weight on Drivers Loaded/ Empty	Turning Circle m (ft)
						Length	Width	Height	Width of Tread			
DW21 & No. 21 Scraper	8W 8	51-55	225/*	11.5/15 (15/20)	24 790 (54,650)	12.37 (40'7")	3.53 (11'7")	3.28 (10'9")	2.13 (7'0")	24.0 × 29-24	—	10.67 (35'0")
DW21C & No. 470 Scraper	58C 69C	55-58	300/*	14/19 (18/25)	26 610 (58,670)	12.67 (41'7")	3.58 (11'9")	3.35 (11'0")	2.24 (7'4")	29.5 × 29-22	52/67	11.00 (36'0")
DW21D & No. 470 Scraper	85E 86E	58-58	320/*	14/19 (18/25)	26 310 (58,010)	12.78 (41'11")	3.58 (11'9")	3.35 (11'0")	2.24 (7'4")	29.5 × 29-22	52/67	11.00 (36'0")
DW21G & No. 470 Scraper	85E 86E	58-60	345/*	14.9/20.6 (19.5/27)	27 210 (59,980)	12.78 (41'11")	3.58 (11'9")	3.48 (11'5")	2.24 (7'4")	29.5 × 29-28	52/67	11.00 (36'0")
611	6SZ	99-03	265	11 (15)	23 900 (52,640)	12.02 (39'5")	3.27 (10'9")	3.24 (10'8")	2.06 (6'9")	29.5R25	66/51	10.2 (33'5")
613A	71M	69-76	/150	8.4 (11)	13 334 (29,395)	9.67 (31'9")	2.44 (8'0")	2.85 (9'4.5")	1.89 (6'2.5")	18.0 × 25-12	49/63	9.04 (29'8")
613B	38W	76-84	/150	8.4 (11)	14 155 (31,210)	9.78 (32'1")	2.44 (8'0")	2.85 (9'4.5")	1.89 (6'2.5")	18.0 × 25-12	49/64	8.94 (29'4")
613C		84-93	175	8.4 (11)	14 670 (32,340)	10.0 (32'9")	2.44 (8'0")	3.06 (10'0")	1.89 (6'2.5")	18.00-25, 16 PR (E-2)	49/63	8.9 (29'4")
613C Series II	8LJ	93-08	175	6.8/8.4 (8.9/11)	15 264 (33,650)	10.14 (33'3")	2.44 (8'0")	3.01 (9'10")	1.80 (5'11")	23.5R25★	49/63	9.0 (29'6")
613G	ESB	08-10	181	6.8/8.4 (8.9/11)	16 887 (37,229)	10.41 (34'2")	2.43 (8'0")	3.01 (9'11")	1.80 (5'11")	23.5R25★	52/66	9.0 (29'6")
615	46Z	81-87	/250	12.23 (16)	23 400 (51,590)	11.6 (38'1")	3.048 (10'0")	3.590 (11'8")	2.21 (7'3")	26.5-25, 26 PR (E-2)	53/65	9.63 (31'7")
615C		87-93	265	12.23 (16)	23 860 (52,600)	11.6 (38'1")	3.048 (10'0")	3.59 (11'9")	2.21 (7'3")	26.5-25, 26 PR (E-2)	53/79	9.63 (31'7")
615C Series II	9XG	93-08	265	11/13 (14/17)	25 605 (56,450)	11.6 (38'1")	3.05 (10'0")	3.5 (11'0")	2.1 (6'9")	29.5R25★	51/66	10.8 (35'6")
619B DD	89E 90E	59-60	/225							Turbocharged, Electric start Turbocharged, Gas start		
619C PS	61F 62F	60-66	280/250	10.8/14 (14/18)	21 550 (47,500)	11.05 (36'3")	3.30 (10'11")	3.76 (12'2")	2.00 (6'7")	26.5 × 29-22	55/69	9.14 (30'0")
619**	43F	64-65	/250	15.3/12.6 (20/16.5)	27 400 (60,390)	11.89 (40'0")	3.60 (11'10")	3.45 (11'4")	2.30 (7'7")	26.5 × 29-26	53/65.8	10.20 (33'6")

\*Maximum HP only available.

\*\*Johnson Manufacturing Company built the J619 Elevating Scraper for Caterpillar in 1964.

## Wheel Tractor-Scrapers (cont'd)

Model	Product Ident. No. Prefix	Years Built	Horsepower Max/ Rated	Capacity Struck/ Heaped m <sup>3</sup> (yd <sup>3</sup> )	Approx. Shipping Weight kg (lb)	Dimensions m (ft)				Tire Size (Standard) & ply rating Tractor & Scraper	Approx. % Weight on Drivers Loaded/ Empty	Turning Circle m (ft)
						Length	Width	Height	Width of Tread			
621	43H	65-72	/300	10.7/15.3 (14/20)	28 400 (62,600)	12.00 (39'5")	3.60 (11'10")	3.45 (11'4")	2.19 (7'3")	29.5 × 29-22	53/68	11.50 (37'8")
621	23H	65-74	/300	10.7/15.3 (14/20)	24 900 (55,000)	11.60 (38'1")	3.50 (11'7")	3.40 (11'2")	2.10 (6'10")	29.5 × 29-22	53/68	13.00 (42'6")
621B	45P	73-86	/330	10.7/15.3 (14/20)	30 205 (66,590)	12.7 (41'7")	3.45 (11'4")	3.63 (11'11")	2.21 (7'3")	29.5-29, 28 PR (E-3)	53/68	11.10 (36'6")
621E	6AB 2PD	86-93	/330	10.7/15.3 (14/20)	30 480 (67,195)	12.93 (42'5")	3.47 (11'4")	3.71 (12'2")	2.21 (7'3")	33.25-29, 26 PR (E-3)	53/68	10.9 (35'8")
621F	4SK	93-00	330	10.7/15.3 (14/20)	32 090 (70,740)	12.93 (42'5")	3.47 (11'4")	3.71 (12'2")	2.21 (7'3")	33.25-29 ★★ (E-2/E-3)	53/68	10.2 (33'5")
621G	ALP	00-03	330/365	10.7/15.3 (14/20)	32 250 (71,090)	12.93 (42'5")	3.47 (11'4")	3.71 (12'2")	2.20 (7'3")	33.25R29	68/53	11.7 (38'5")
621G	CEN	03-05	330/365	12/17 (15.7/22)	32 563 (71,790)	12.93 (42'5")	3.47 (11'4")	3.71 (12'2")	2.20 (7'3")	33.25R29	68/53	11.7 (38'5")
623	52U	72-74	/300	16.8 (22)	29 900 (66,000)	11.90 (39'0")	3.50 (11'7")	3.70 (12'1")	2.20 (7'3")	29.5 × 29-28	53/68	13.70 (44'11")
623B	46P	73-86	/330	16.8 (22)	32 546 (71,750)	12.5 (41'1")	3.55 (11'8")	3.81 (12'6")	2.18 (7'2")	29.5-29, 28 PR (E-2)	53/68	8.90 (29'4")
623E	6CB	86-89	/330	16.8 (22)	33 317 (73,450)	12.61 (41'4")	3.55 (11'8")	3.81 (12'6")	2.21 (7'3")	29.5-29, 34 PR (E-2)	52/65	10.9 (35'9")
623E	6YF	89-93	/365	13.8/17.6 (18/23)	35 290 (77,800)	12.61 (41'4")	3.55 (11'8")	3.94 (12'11")	2.18 (7'2")	29.5R25	51/66	10.9 (35'8")
623F	6BK	93-98	365	13.8/17.6 (18/23)	35 305 (77,830)	12.61 (41'4")	3.55 (11'8")	3.94 (12'11")	2.18 (7'2")	29.5-29, 34 PR (E-2)	51/66	10.9 (35'8")
623F Series II	5EW	98-00	365	13.8/17.6 (18/23)	37 122 (81,840)	13.28 (43'7")	3.55 (11'8")	3.55 (11'8")	2.21 (7'3")	33.25-R29 ★★ (E-2)	50/64	8.6 (28'5")
623G	ARW	00-02	330/365	13.8/17.6 (18/23)	37 120 (81,840)	13.21 (43'4")	3.55 (11'8")	3.68 (12'1")	2.2 (7'3")	33.25R29	64/50	10.9 (35'8")
623G	CES	03-05	330/365	13.8/17.6 (18/23)	37 120 (81,840)	13.21 (43'4")	3.55 (11'8")	3.68 (12'1")	2.2 (7'3")	33.25R29	64/50	10.9 (35'8")

Wheel Tractor-Scrapers (cont'd)

Model	Product Ident. No. Prefix	Years Built	Horsepower Max/ Rated	Capacity Struck/ Heaped m <sup>3</sup> (yd <sup>3</sup> )	Approx. Shipping Weight kg (lb)	Dimensions m (ft)				Tire Size (Standard) & ply rating Tractor & Scraper	Approx. % Weight on Drivers Loaded/ Empty	Turning Circle m (ft)
						Length	Width	Height	Width of Tread			
627	54K	68-74	T/225 S/225	10.7/15.3 (14/20)	29 900 (66,000)	12.00 (36'9")	3.50 (11'7")	3.60 (11'8")	2.20 (7'3")	29.5 × 29-28	47/56	13.30 (43'9")
627B	14S	73-86	T/225 S/225	10.7/15.3 (14/20)	34 610 (76,300)	13.3 (43'9")	3.45 (11'4")	3.63 (11'11")	2.18 (7'2")	29.5-29, 28 PR (E-3)	49/58	11.10 (36'6")
627E	6EB	86-90	T/225 S/225	10.7/15.3 (14/20)	34 670 (76,435)	12.89 (42'3")	3.47 (11'4")	3.71 (12'2")	2.21 (7'3") 2.18 (7'2")	33.25-29, 26 PR (E-3)	48/59	10.90 (35'9")
627E	7CG	90-93	T/330 S/225	10.7/15.3 (14/20)	35 160 (77,500)	12.93 (42'5")	3.47 (11'4")	3.71 (12'2")	2.21 (7'3")	33.25-29, 26 PR (E-3)	48/59	10.9 (35'8")
627F Series II	1DL	93-00	T/330 S/225	10.7/15.3 (14/20)	37 060 (81,640)	12.9 (42'5")	3.47 (11'4")	3.71 (12'2")	2.21 (7'3")	33.25-R29 ★★ (E-2/E-3)	49/60	10.9 (35'9")
627B/PP	15S	73-86	T/225 S/225	10.7/15.3 (14/20)	35 660 (78,620)	14.91 (48'11")	3.45 (11'4")	3.63 (11'11")	2.18 (7'2")	29.5-29, 28 PR (E-3)	51/60	11.1 (36'6")
627E/PP	6GB	86-89	T/225 S/225	10.7/15.3 (14/20)	36 130 (79,655)	12.89 (42'3")	3.47 (11'4")	3.71 (12'2")	2.21 (7'3") 2.18 (7'2")	33.25-29, 26 PR (E-3)	49/60	10.90 (35'9")
627E/PP	7CG	90-93	T/330 S/225	10.7/15.3 (14/20)	36 620 (80,735)	15.2 (49'7")	3.47 (11'4")	3.71 (12'2")	2.21 (7'3")	33.25-29, 26 PR (E-3)	49/60	10.9 (35'8")
627F/PP Series II	1DL	93-00	T/330 S/225	10.7/15.3 (14/20)	38 103 (84,000)	15.2 (49'7")	3.47 (11'4")	3.71 (12'2")	2.21 (7'3")	33.25-R29 ★★ (E-2/E-3)	50/60	10.9 (35'9")
627G/PP	AXF	00-02	T/330/365 S/225	10.7/15.3 (14/20)	38 140 (84,075)	15.2 (49'7")	3.47 (11'4")	3.71 (12'2")	2.20 (7'3")	33.25R29	60/49	11.7 (38'5")
627G/PP	CEX	02-05	T/330/365 S/225/249	12/17 (15.7/22)	39 186 (86,390)	15.2 (49'7")	3.47 (11'4")	3.71 (12'2")	2.20 (7'3")	33.25R29	60/49	11.7 (38'5")
630A & 482C Scraper	52F	60-62	420/335	21/27 (27/35)	35 830 (79,000)	14.63 (48'0")	3.91 (12'10")	4.01 (13'2")	2.39 (7'10") Scraper	16.0 × 25-16 29.5 × 35-28 33.5 × 33-26	37/42	11.89 (39'0")
630A	52F	60-62	420/335	16/21.4 (21/28)	31 430 (69,300)	13.82 (45'4")	3.58 (11'9")	3.73 (12'3")	2.21 (7'3")	16.0 × 25-16 29.5 × 35-28	39/45	11.89 (39'0")
630B	14G	62-63	420/335	16/23 (21/30)	33 520 (73,900)	14.12 (46'4")	3.81 (12'6")	3.71 (12'2")	2.41 (7'11")	16.0-25, 16 29.5-35, 28	38/42	13.36 (43'10")
630B	14G	63-66	400/360	16/23 (21/30)	33 570 (74,000)	14.30 (46'11")	3.81 (12'6")	3.94 (12'11")	2.41 (7'11")	16.0-25, 16 29.5-35, 34	37/42	13.36 (43'10")
630B	10G	62-69	/400	16/23 (21/30)	35 750 (78,800)	14.35 (47'1")	3.81 (12'6")	3.94 (12'11")	2.40 (7'10")	16.0-25, 16 29.5-35, 34	38/44	13.36 (43'10")

## Wheel Tractor-Scrapers (cont'd)

Model	Product Ident. No. Prefix	Years Built	Horse-power Max/ Rated	Capacity Struck/ Heaped m <sup>3</sup> (yd <sup>3</sup> )	Approx. Shipping Weight kg (lb)	Dimensions m (ft)				Tire Size (Standard) & ply rating Tractor & Scraper	Approx. % Weight on Drivers Loaded/ Empty	Turning Circle m (ft)
						Length	Width	Height	Width of Tread			
631A	51F	60-62	420/335	16/21.4 (21/28)	30 250 (66,700)	12.88 (42'3")	3.58 (11'9")	3.56 (11'8")	2.21 (7'3")	29.5-35, 28	54/69	11.00 (36'0")
631B	13G	62-62	420/335	16/23 (21/30)	31 620 (69,700)	13.05 (42'10")	3.81 (12'6")	3.45 (11'5")	2.39 (7'10")	29.5-35, 28	51/67	11.31 (37'5")
631B	13G	62-66	420/360	16/23 (21/30)	31 840 (70,200)	13.29 (43'7")	3.81 (12'6")	3.63 (11'11")	2.41 (7'11")	29.5-35, 34	52/67	11.31 (37'5")
631C	67M	69-75	/415	16/23 (21/30)	36 350 (80,150)	13.54 (44'5")	3.45 (11'4")	3.91 (12'10")	2.39 (7'10")	29.5-35, 34	52/67	11.45 (37'7")
631D	24W	75-85	473/450	16/23.7 (21/31)	42 370 (93,410)	14.25 (46'9")	3.96 (13'0")	4.17 (13'8")	2.46 (8'1")	33.25-35, 38 PR (E-3)	52/68	12.2 (40'1")
631E	1AB	85-91	473/450	16.1/23.7 (21/31)	43 365 (95,600)	14.28 (46'10")	3.94 (12'11")	4.29 (14'1")	2.46 (8'1")	37.25-35, 30	53/67	12.2 (40'1")
631E Series II	1AB	91-01	473/450	16.1/23.7 (21/31)	44 210 (97,460)	14.56 (47'9")	3.94 (12'11")	4.29 (14'1")	2.46 (8'1")	37.25R35	53/67	12.2 (40'1")
631G	AWK	00-02	450/485	16.1/23.7 (21/31)	46 475 (102,460)	14.56 (47'9")	3.94 (12'11")	4.29 (14'1")	2.46 (8'1")	37.25R35	67/53	12.2 (40'1")
631G	CLR	03-05	450/485	18.3/26 (24/34)	46 475 (102,460)	14.56 (47'9")	3.94 (12'11")	4.29 (14'1")	2.46 (8'1")	37.25R35	67/53	12.2 (40'1")
632	14G	62-63	420/335	21.4/29 (28/38)	37 650 (83,000)	15.21 (49'11")	4.04 (13'3")	4.00 (13'1")	2.44 (8'0")	16.0-25, 16 29.5-35, 34	37/41	13.36 (43'10")
632	14G	63-66	420/360	21.4/29 (28/38)	39 420 (86,910)	15.30 (50'2")	4.04 (13'3")	4.00 (13'1")	2.44 (8'0")	16.0-25, 16 29.5-35, 34	37/41	13.36 (43'10")
633C	66M	69-75	/415	24.5 (32)	41 750 (92,050)	13.36 (43'10")	3.45 (11'4")	3.96 (13'0")	2.39 (7'10")	33.2-35, 32	52/66	11.78 (38'8")
633D	25W	75-85	450	17.7/23 (23/34)	47 570 (104,870)	14.40 (47'3")	3.96 (13'0")	4.24 (13'11")	2.46 (8'1")	33.25-35, 38 PR (E-3)	51/66	12.4 (40'7")
633E	1AB	92-96	475	17.7/23 (23/34)	50 800 (112,000)	14.40 (47'3")	3.96 (13'0")	4.24 (13'11")	2.46 (8'1")	37.25R35	51/64	13.15 (43'2")
633E Series II	2PS	96-00	490	17.7/23 (23/34)	51 100 (112,670)	14.8 (48'7")	3.96 (13'0")	4.24 (13'11")	2.46 (8'1")	37.25R35	51/64	13.15 (43'2")
637	65M	70-75	T/415 S/225	16/23 (21/30)	41 300 (91,050)	13.65 (44'9.5")	3.45 (11'4")	3.93 (12'11")	2.39 (7'10")	33.25-35, 32	49/60	11.68 (38'4")
637/PP	79P	70-75	T/415 S/225	16/23 (21/30)	43 700 (96,350)	15.82 (51'11")	3.45 (11'4")	3.93 (12'11")	2.39 (7'10")	33.25-35, 32	51/63	11.68 (38'4")
637D	26W	75-85	T/450 S/250	16/23 (21/31)	46 987 (103,590)	14.8 (48'8")	3.96 (13'0")	4.17 (13'8")	2.46 (8'1")	33.25-35, 38 PR (E-3)	50/61	12.2 (40'1")
637D/PP	27W	75-85	T/450 S/250	16/23 (21/31)	48 531 (106,990)	14.8 (48'8")	3.96 (13'0")	4.17 (13'8")	2.46 (8'1")	33.25-35, 38 PR (E-3)	50/61	12.2 (40'1")
637E	1FB	85-91	T/450 S/250	16/23 (21/31)	49 940 (110,100)	14.28 (46'10")	3.94 (12'11")	4.29 (14'1")	2.46 (8'1")	37.25-35, 30	49/59	12.2 (40'1")
637E Series II	1FB	91-01	T/450 S/250	16/23 (21/31)	50 990 (112,320)	14.56 (47'9")	3.94 (12'11")	4.29 (14'1")	2.46 (8'1")	37.25R35	49/59	12.2 (40'1")
637E/PP	1FB	85-91	T/450 S/250	16/23 (21/31)	51 485 (113,500)	15.88 (52'1")	3.94 (12'11")	4.29 (14'1")	2.46 (8'1")	37.25-35, 30	50/60	12.2 (40'1")
637E Series II/PP	1FB	91-01	T/450 S/250	16/23 (21/31)	52 385 (115,490)	16.49 (54'1")	3.94 (12'11")	4.29 (14'1")	2.46 (8'1")	37.25R35	50/60	12.2 (40'1")
637G/PP	AXT	00-02	T/450/485 S/249	16.1/23.7 (21/31)	53 590 (118,150)	16.49 (54'1")	3.94 (12'11")	4.29 (14'1")	2.46 (8'1")	37.25R35	61/50	12.2 (40'1")
637G/PP	CEH	02-05	T/450/485 S/249/274	18.3/26 (24/34)	53 562 (118,084)	16.49 (54'1")	3.94 (12'11")	4.29 (14'1")	2.46 (8'1")	37.25R35	61/50	12.2 (40'1")

## Wheel Tractor-Scrapers (cont'd)

Model	Product Ident. No. Prefix	Years Built	Horsepower Max/ Rated	Capacity Struck/ Heaped m <sup>3</sup> (yd <sup>3</sup> )	Approx. Shipping Weight kg (lb)	Dimensions m (ft)				Tire Size (Standard) & ply rating Tractor & Scraper	Approx. % Weight on Drivers Loaded/ Empty	Turning Circle m (ft)
						Length	Width	Height	Width of Tread			
639D	99X	79-84	T/450 S/250	26 (34)	55 030 (121,318)	14.53 (47'8")	3.96 (13'0")	4.06 (13'4")	2.46 (8'1")	37.25-35, 42 37.25-35, 42	51/59	12.4 (40'7")
641	64F	62-65	560/450	21.4/29 (28/38)	43 200 (95,300)	14.73 (48'4")	4.04 (13'3")	4.00 (13'1")	2.44 (8'0")	33.5-39, 38	52/67	12.68 (41'7")
641B	65K	69-81	/550	21.4/29 (28/38)	53 070 (117,000)	14.96 (49'1")	4.04 (13'3")	4.24 (13'11")	2.55 (8'4")	37.5-39, 36	54/69	13.00 (42'9")
650	63F	62-64	560/450	24.5/33.6 (32/44)	45 130 (99,500)	16.31 (53'6")	4.24 (13'11")	4.01 (13'2")	2.54 (8'4")S	18.0-25, 20 33.5-39, 32 37.5-39, 36	37/41	13.87 (45'6")
650B	22G	62-72	/550	24.5/33.6 (32/44)	46 100 (101,700)	17.00 (55'10")	3.80 (12'6")	4.30 (14'1")	2.65 (8'9")S	18.0-25, 20 37.5-39, 28 37.5-30, 36	40/46	14.00 (46'0")
651	33G	62-68	560/450	24.5/33.6 (32/44)	43 730 (96,400)	14.93 (49'0")	4.24 (13'11")	4.01 (13'2")	2.54 (8'4")	37.5-39, 36	51/65	13.29 (43'7")
651B	67K	69-84	/550	24.5/33.6 (32/44)	56 340 (124,200)	15.34 (51'4")	4.32 (14'2")	4.29 (14'1")	2.72 (8'11")S	37.5-39, 36 37.5-39, 36	52/67	13.5 (44'2")
651E	89Z	82-96	550	24.5/33.6 (32/44)	59 420 (131,000)	16.13 (52'11")	4.37 (14'4")	4.7 (15'5")	2.64 (8'8")	37.5R39	69/54	14.5 (47'7")
651E	4YR	96-06	550/605	24.5/33.6 (32/44)	61 126 (134,760)	16.18 (53'1")	4.37 (14'4")	4.7 (15'5")	2.64 (8'8")	40.5/75R39	66/47	15.1 (49'8")
657	31G	62-68	T/450 S/335	24.5/33.6 (32/44)	56 550 (124,700)	15.39 (50'6")	4.24 (13'11")	4.09 (13'5")	2.62 (8'7")	37.5-39, 44	48/55	13.29 (43'7")
657	46M	68-69	T/500 S/400	24.5/33.6 (32/44)	56 820 (125,155)	15.39 (50'6")	4.24 (13'11")	4.09 (13'5")	2.67 (8'8")	37.5-39, 44	48/55	14.57 (47'10")
657B	68K	69-84	T/550 S/400	24.5/33.6 (32/44)	63 100 (139,100)	15.7 (51'8")	4.32 (14'2")	4.21 (13'10")	2.67 (8'9")S	37.5-39, 44 37.5-39, 44	49/57	13.7 (45'1")
657E	90Z	82-95	T/550 S/400	24.5/33.6 (32/44)	68 720 (151,500)	17 (55'10")	4.37 (14'4")	4.7 (15'5")	2.64 (8'8")	37.5R39	61/50	14.5 (47'7")
657E	6TR	96-06	T/550/605 S/400/440	24.5/33.6 (32/44)	69 078 (152,290)	16.2 (53'1")	4.37 (14'4")	4.7 (15'5")	2.64 (8'8")	40.5/75R39	60/51	15.1 (49'8")
657E/PP	91Z	82-95	T/550 S/400	24.5/33.6 (32/44)	72 120 (159,000)	18.01 (59'1")	4.37 (14'4")	4.7 (15'5")	2.64 (8'8")	37.5R39	61/52	14.5 (47'7")
657E/PP	5YR	96-06	T/550/605 S/400/440	24.5/33.6 (32/44)	72 857 (160,623)	18.01 (59'1")	4.37 (14'4")	4.7 (15'5")	2.64 (8'8")	40.5/75R39	60/51	15.1 (49'8")
660	90F	62-64	560/450	30.6/41.3 (40/54)	49 130 (108,300)	17.04 (55'11")	4.24 (13'11")	4.37 (14'4")	2.59 (8'6") Scrapper	18.0 × 25-20 37.5 × 39-28 37.5 × 51-36	37/40	13.87 (45'6")
660B	58K	70-78	/550	30.6/41.3 (40/54)	59 875 (132,000)	17.27 (56'8")	3.81 (14'2")	4.37 (14'4")		18.0 × 25-20 37.5 × 39-28	40/45	14.00 (46'0")
666	77F	63-69	T/450 S/335	30.6/41.3 (40/54)	56 700 (125,000)	17.04 (55'11")	4.24 (13'11")	4.37 (14'4")	2.59 (8'6") Scrapper	18.0 × 25-20 37.5 × 39-28 37.5 × 51-36	35/34	13.87 (45'6")
666	64H	67-69	T/500 S/400	30.6/41.3 (40/54)	58 800 (129,645)	17.27 (56'8")	4.24 (13'11")	4.37 (14'4")	2.59 (8'6") Scrapper	18.0 × 25-20 37.5 × 39-28 37.5 × 51-51	36/35	13.87 (45'6")
666B	66K	69-78	T/550 S/400	30.6/41.3 (40/54)	67 630 (149,500)	17.27 (56'8")	4.31 (14'4")	4.37 (14'4")	2.59 (8'9")	18.0 × 25-20 37.5 × 39-28	37/42	14.00 (46'0")



## TRACTOR-TOWED SCRAPERS

Model	Product Ident. No. Prefix	Years Built	Capacity Struck/Heaped m <sup>3</sup> (yd <sup>3</sup> )	Weight kg (lb)	Width m (ft)	Length m (ft)	Height m (ft)	Width of Cut m (ft)
40	1W	49-59	2.8/3.4 <b>(3.6/4.5)</b>	3348 <b>(7380)</b>	2.27 <b>(7'6")</b>	6.40 <b>(21'0")</b>	1.68 <b>(5'6")</b>	1.82 <b>(6'0")</b>
60	1D	47-53	4.6/6.1 <b>(6.0/8.0)</b>	5579 <b>(12,300)</b>	2.65 <b>(8'9")</b>	8.43 <b>(27'8")</b>	2.36 <b>(7'9")</b>	2.13 <b>(7'0")</b>
60	2W	52-72	5.4/7.0 <b>(7.0/9.0)</b>	6100 <b>(13,500)</b>	2.85 <b>(9'5")</b>	8.52 <b>(28'3")</b>	2.36 <b>(7'9")</b>	2.40 <b>(7'11")</b>
70	8C	46-53	6.7/8.4 <b>(8.7/11.0)</b>	8527 <b>(18,800)</b>	3.02 <b>(10'0")</b>	9.50 <b>(31'2")</b>	2.56 <b>(8'5")</b>	2.43 <b>(8'0")</b>
70	3W	51-57	7.8/9.9 <b>(10.2/13.0)</b>	9140 <b>(20,150)</b>	3.16 <b>(10'5")</b>	9.53 <b>(31'4")</b>	2.61 <b>(8'7")</b>	2.59 <b>(8'6")</b>
80	2D	46-52	10.3/13.8 <b>(13.5/18.0)</b>	11 793 <b>(26,000)</b>	3.38 <b>(11'2")</b>	10.82 <b>(35'6")</b>	2.92 <b>(9'7")</b>	2.74 <b>(9'0")</b>
80	5W	50-56	11.5/15.3 <b>(15.0/20.0)</b>	13 533 <b>(29,836)</b>	3.50 <b>(11'6")</b>	10.92 <b>(35'0")</b>	3.09 <b>(10'2")</b>	2.89 <b>(9'6")</b>
90	9V	51-55	16.2/20.6 <b>(21.2/27.0)</b>	17 208 <b>(37,937)</b>	3.65 <b>(12'0")</b>	12.19 <b>(40'0")</b>	3.20 <b>(10'6")</b>	3.04 <b>(10'0")</b>
435C	45D	56-61	9.9/13.8 <b>(13.0/18.0)</b>	10 659 <b>(23,500)</b>	3.28 <b>(10'10")</b>	10.16 <b>(33'4")</b>	3.01 <b>(9'11")</b>	2.84 <b>(9'4")</b>
435D	45D	59-61	11.5/14.5 <b>(15.0/19.0)</b>	11 521 <b>(25,400)</b>	3.29 <b>(10'10")</b>	10.16 <b>(33'4")</b>	3.01 <b>(9'11")</b>	2.84 <b>(9'4")</b>
435E	85F	61-72	9.2/13.0 <b>(12.0/17.0)</b>	10 400 <b>(22,900)</b>	3.29 <b>(10'10")</b>	10.06 <b>(33'1")</b>	3.07 <b>(10'1")</b>	2.84 <b>(9'4")</b>
435F	45D	62-72	10.7/13.8 <b>(14.0/18.0)</b>	11 300 <b>(24,900)</b>	3.29 <b>(10'10")</b>	10.06 <b>(33'1")</b>	3.02 <b>(9'11")</b>	2.84 <b>(9'4")</b>
435G	27G	63-73	9.2/13.0 <b>(12.0/17.0)</b>	10 400 <b>(22,900)</b>	3.27 <b>(10'9")</b>	10.08 <b>(33'1")</b>	2.97 <b>(9'9")</b>	2.84 <b>(9'4")</b>
463	62C	55-60	13.8/29.1 <b>(18.0/25.0)</b>	14 061 <b>(31,000)</b>	3.58 <b>(11'9")</b>	11.58 <b>(38'0")</b>	3.39 <b>(11'2")</b>	3.15 <b>(10'4")</b>
463C	62C	59-60	16.8/21.4 <b>(22.0/28.0)</b>	15 785 <b>(34,800)</b>	3.58 <b>(11'9")</b>	11.58 <b>(38'0")</b>	3.39 <b>(11'2")</b>	3.15 <b>(10'4")</b>
463E	86F	60-71	13.8/20.0 <b>(18.0/26.0)</b>	15 600 <b>(34,400)</b>	3.58 <b>(11'9")</b>	11.65 <b>(38'3")</b>	3.28 <b>(10'10")</b>	3.15 <b>(10'4")</b>
463F	62C	63-71	16.0/21.4 <b>(21.0/28.0)</b>	15 700 <b>(34,600)</b>	3.58 <b>(11'9")</b>	11.65 <b>(38'3")</b>	3.28 <b>(10'10")</b>	3.15 <b>(10'4")</b>
463G	28G	63-71	13.8/20.0 <b>(18.0/26.0)</b>	13 200 <b>(29,200)</b>	3.58 <b>(11'9")</b>	11.52 <b>(37'10")</b>	3.14 <b>(10'4")</b>	3.15 <b>(10'4")</b>
491	98C	56-64	20.6/26.0 <b>(27.0/34.0)</b>	16 964 <b>(37,400)</b>	3.65 <b>(12'0")</b>	12.13 <b>(39'10")</b>	3.96 <b>(13'0")</b>	3.16 <b>(10'5")</b>
491B	9A	61-63	20.6/26.8 <b>(27.0/35.0)</b>	20 902 <b>(46,060)</b>	3.91 <b>(12'10")</b>	12.49 <b>(41'0")</b>	3.96 <b>(13'0")</b>	3.30 <b>(10'10")</b>
491C	47E	63-70	20.6/26.8 <b>(27.0/35.0)</b>	21 600 <b>(47,500)</b>	3.91 <b>(12'10")</b>	12.64 <b>(41'6")</b>	3.96 <b>(13'0")</b>	3.30 <b>(10'10")</b>



CONSTRUCTION & MINING TRUCKS/TRACTORS

Model	Product Ident. No. Prefix	Years Built	Flywheel Kilowatts (Horsepower)	Capacity Metric Tons (U.S. Tons)	Approx. Weight kg (lb)	Dimensions m (ft)						Tire Size
						Width	Length	Height	Loading Height	Dumping Height (55°)	Turning Circle	
768B	79S	71-78	309 (415)	— —	22 000 (48,500)	3.61 (11'10")	6.55 (21'6")	3.48 (11'5")	— —	— —	18.0 (59'1")	18.00 × 33—24 PR
768C	02X	78-95	336 (450)	— —	24 624 (54,285)	4.70 (15'5")	8.00 (26'3")	3.56 (11'8")	— —	— —	18.5 (60'8")	18.00R33 E-4
769	99F	62-67	298 (400)	31.8 (35.0)	25 365 (55,870)	3.63 (11'11")	7.64 (25'1")	4.05 (13'4")	3.07 (10'1")	7.18 (26'7")	16.5 (54'5")	18.00 × 25—32 PR
769B	99F	67-78	309 (415)	32.0 (35.0)	28 000 (61,800)	3.64 (11'11.5")	7.85 (25'9")	3.89 (12'9")	3.15 (10'4")	7.24 (23'9")	18.0 (59'1")	18.00 × 25—32 PR E-3
769C	01X	78-95	336 (450)	36.9 (40.6)	30 675 (67,855)	4.70 (15'5")	8.00 (26'3")	3.85 (12'8")	3.24 (10'7")	7.68 (25'2")	18.5 (60'8")	18.00R33 E-4
769D	5TR, 5SS, BBB	95-06	363 (487)	36.4 (40.0)	33 875 (74,682)	5.07 (16'8")	8.24 (27'0")	4.03 (13'3")	3.14 (10'4")	7.71 (25'4")	17 (55'9")	18.00R33
771C	3BJ	92-95	336 (450)	40.0 (44.0)	34 170 (75,345)	4.74 (15'7")	8.20 (26'11")	4.00 (13'1")	3.30 (10'10")	7.68 (25'2")	18.5 (60'8")	18.00R33 E-4
771D	6JR, 6YS, BCA	96-06	363 (487)	41 (45)	33 784 (74,482)	5.07 (16'8")	8.40 (27'7")	4.02 (13'2")	3.40 (11'1")	7.74 (25'5")	17 (55'9")	18.00R33
772	80S	71-78	447 (600)	— —	32 100 (70,800)	4.06 (13'4")	7.11 (23'4")	3.68 (12'1")	— —	— —	22.1 (72'6")	24.00 × 35—36 PR
772B	64W	78-95	485 (650)	— —	32 909 (72,550)	4.86 (15'11")	9.12 (29'11")	4.52 (14'10")	— —	— —	23.5 (77'0")	24.00R35 E-4
773	63G	70-78	447 (600)	45.4 (50.0)	37 800 (83,360)	4.06 (13'4")	8.71 (28'7")	4.27 (14'0")	3.61 (11'10")	8.36 (27'5")	22.1 (72'6")	21.00 × 35—32 PR E-3
773B	63W	78-95	485 (650)	54.3 (59.8)	38 321 (84,500)	4.86 (15'11")	9.12 (29'11")	4.31 (14'2")	3.77 (12'5")	8.72 (28'7")	23.5 (77'0")	24.00R35 E-4
773D	7CS, 7ER	96-01	485 (650)	52.9 (58.4)	43 600 (96,000)	5.08 (16'8")	9.21 (29'11")	4.42 (14'6")	3.79 (12'5")	8.82 (28'11")	22.0 (72'2")	24.00R35
773E	BDA (U.S.)	01-06	501 (671)	54.4 (60.0)	45 480 (100,180)	5.08 (16'8")	9.21 (29'11")	4.42 (14'6")	3.79 (12'5")	8.82 (28'11")	22.0 (72'2")	24.00R35
775B	7XJ	92-95	485 (650)	59.5 (65.5)	42 324 (93,325)	4.91 (16'2")	9.33 (30'7")	4.31 (14'2")	3.86 (12'8")	8.72 (28'8")	23.5 (77'7")	24.00R35 E-4
775D	6KR, 8AS	95-01	517 (693)	63.4 (69.9)	43 200 (95,300)	5.08 (16'8")	9.30 (30'6")	4.42 (14'6")	3.91 (12'10")	8.82 (28'11")	22.0 (72'2")	24.00R35
775E	BEC	01-06	544 (730)	63.5 (70.0)	43 470 (95,810)	5.08 (16'8")	9.21 (29'11")	4.42 (14'6")	3.91 (12'10")	8.82 (28'11")	22.0 (72'2")	24.00R35
776	14H	75-84	649 (870)	— —	49 686 (109,540)	3.51 (11'6")	8.06 (26'5.5")	3.40 (11'2")	— —	— —	26.8 (88'0")	27.00 × 49—36 PR E-3
776B	6JC	84-92	649 (870)	— —	49 896 (110,000)	3.51 (11'6")	8.06 (26'6")	3.40 (11'2")	— —	— —	25.8 (84'6")	27.00 × 49—36 PR E-3
776C	2TK	92-96	649 (870)	— —	49 896 (110,000)	3.51 (11'6")	8.06 (26'5.5")	4.55 (14'11")	— —	— —	25.8 (84'6")	27.00R49

## Construction &amp; Mining Trucks/Tractors (cont'd)

Model	Product Ident. No. Prefix	Years Built	Flywheel Kilowatts (Horsepower)	Capacity Metric Tons (U.S. Tons)	Approx. Weight kg (lb)	Dimensions m (ft)						Tire Size
						Width	Length	Height	Loading Height	Dumping Height (55°)	Turning Circle	
777	84A	74-84	649 (870)	77.1 (85.0)	58 886 (129,820)	5.463 (17'11")	9.78 (32'1")	4.90 (16'1")	4.14 (13'7")	9.29 (30'6")	26.8 (88'0")	24.00 × 49—42 PR E-3
777B	4YC	84-92	649 (870)	86.2 (95.0)	60 055 (132,422)	5.463 (17'11")	9.79 (32'1")	4.97 (16'4")	4.17 (13'8")	9.42 (30'11")	25.8 (84'6")	24.00 × 49—48 PR E-3
777C	4XJ	92-96	649 (870)	86.2 (95.0)	61 790 (136,227)	5.463 (17'11")	9.79 (32'1")	4.97 (16'4")	4.17 (13'8")	9.42 (30'11")	25.8 (84'6")	27.00R49
777D (Decatur)	2YW, AGC (U.S.)	96-06	699 (938)	90.9 (100.0)	72 575 (160,000)	6.11 (20'0")	9.78 (32'1")	5.15 (16'10")	4.38 (14'4")	10.06 (33'0")	25.3 (83'0")	27.00R49
784B	5RK	93-98	962 (1290)	— (—)	89 280 (196,825)	6.74 (22'2")	9.34 (30'8")	5.47 (17'1")	— (—)	— (—)	33.5 (109'10")	36.00R51 E-3
784C	2PZ	98-09	1005 (1348)	— (—)	88 746 (195,651)	7.00 (23'0")	9.34 (30'8")	5.47 (17'1")	— (—)	— (—)	33.8 (110'11")	36.00R51
785	8GB	85-92	962 (1290)	136.0 (150.0)	96 353 (212,458)	6.64 (21'9")	11.02 (36'2")	5.77 (18'11")	4.98 (16'4")	11.20 (36'9")	30.5 (100'4")	33.00 × 51
785B	6HK	92-98	962 (1290)	136.0 (150.0)	96 353 (212,458)	6.64 (21'9")	11.02 (36'2")	5.77 (18'11")	4.98 (16'4")	11.20 (36'9")	30.2 (99'2")	33.00R51
789	9ZC	86-92	1272 (1705)	177.0 (195.0)	121 922 (268,837)	7.67 (25'2")	12.18 (39'11")	6.15 (20'2")	5.21 (17'1")	11.91 (39'1")	30.2 (99'2")	37.00R57
789B	7EK	92-98	1272 (1705)	177.0 (195.0)	121 922 (268,837)	7.67 (25'2")	12.18 (39'11")	6.15 (20'2")	5.21 (17'1")	11.91 (39'1")	30.2 (99'2")	37.00R57
793	3SJ	90-92	1534 (2057)	218.0 (240.0)	376 482 (830,000)	7.60 (24'11")	12.86 (42'3")	6.43 (21'1")	5.86 (19'3")	13.21 (43'4")	30.2 (99'2")	40.00-57
793B	1HL	92-96	1534 (2057)	218.0 (240.0)	376 482 (830,000)	7.60 (24'11")	12.86 (42'3")	6.43 (21'1")	5.86 (19'3")	13.21 (43'4")	30.2 (99'2")	40.00R57
793C	4AR, 4GZ, ATY	96-04	1615 (2166)	218.0 (240.0)	383 739 (846,000)	7.41 (24'4")	12.87 (42'3")	6.43 (21'1")	5.86 (19'3")	13.21 (43'4")	32.4 (106'4")	40.00R57
797	5YW	98-02	2395 (3211)	326.0 (360.0)	557 820 (1,230,000)	9.14 (30'0")	14.63 (48'0")	7.24 (27'6")	7.05 (26'10")	14.94 (49'0")	32.86 (104'10")	55/80R63
797B	JSM	02-09	2513 (3370)	354.0 (394.0)	623 583 (1,375,000)	9.66 (31'9")	14.4 (47'3")	7.72 (25'4")	7.15 (23'6")	15.34 (50'4")	40.5 (132'10")	59/80/R63





## ARTICULATED TRUCKS

Model	Product Ident. No. Prefix	Years Built	Flywheel Kilowatts (Horsepower)	Capacity Metric Tons (U.S. Tons)	Approx. Weight kg (lb)	Dimensions m (ft)						Tire Size
						Width	Length	Height	Loading Height	Dumping Height (55°)	Turning Circle	
D20D	9MG	92-94	134 (180)	18.0 (20.0)	15 000 (33,070)	2.75 (9'0")	8.43 (27'8")	3.30 (10'10")	2.40 (7'11")	5.00 (16'5")	7.25 (24'0")	23.5R25
D22	*	80-82	175 (235)	20.0 (22.0)	17 700 (39,000)	3.00 (9'10")	7.85 (25'9")	3.09 (10'2")	2.44 (8'0")	5.03 (16'6")	7.87 (25'10")	26.5R25
D25	*	80	175 (235)	22.7 (25.0)	17 300 (38,000)	3.00 (9'10")	7.85 (25'9")	3.09 (10'2")	2.44 (8'0")	5.03 (16'6")	7.87 (25'10")	26.5R25
D25B	*	80-83	190 (255)	22.7 (25.0)	17 900 (39,400)	3.00 (9'10")	7.99 (26'2")	3.25 (10'8")	2.44 (8'0")	5.03 (16'6")	7.87 (25'10")	26.5R25
D25C	9YC	85-89	194 (260)	22.7 (25.0)	19 233 (42,400)	3.00 (9'10")	8.73 (28'8")	3.27 (10'9")	2.56 (8'5")	5.28 (17'4")	16.14 (52'11")	26.5R25
D25D	1HK	89-01	194 (260)	22.7 (25.0)	19 450 (42,880)	3.00 (9'10")	8.79 (28'10")	3.34 (10'11")	2.63 (8'8")	5.19 (17'0")	7.95 (26'1")	26.5R25
D30C	7ZC	85-89	194 (260)	27.2 (30.0)	21 320 (47,000)	3.30 (10'10")	8.86 (29'1")	3.33 (10'11")	2.85 (9'4")	5.46 (17'11")	16.33 (53'7")	29.5R25
D30D	3AJ	89-01	213 (285)	27.2 (30.0)	21 690 (47,320)	3.30 (10'10")	8.89 (29'2")	3.40 (11'2")	2.83 (9'3")	5.46 (17'11")	8.20 (26'11")	29.5R25
D35	*	81-83	190 (255)	31.8 (35.0)	20 000 (44,000)	3.27 (10'9")	8.44 (27'8")	3.25 (10'8")	2.91 (9'7")	5.46 (17'11")	7.87 (25'10")	26.5R25 33.25R29
D35C	2GD	85-89	194 (260)	31.8 (35.0)	23 860 (52,600)	3.50 (11'6")	9.44 (31'0")	3.34 (10'11")	2.93 (9'7")	5.32 (17'5")	16.00 (52'5")	Front 29.5R25 Rear 33.5R29
D35 HP	3FD	85-89	287 (385)	31.8 (35.0)	24 950 (55,000)	3.50 (11'6")	9.80 (32'2")	3.51 (11'6")	2.93 (9'7")	5.32 (17'5")	15.78 (51'9")	Front 29.5R25 Rear 33.5R29
D40D	2JJ	89-94	287 (385)	36.3 (40.0)	28 027 (61,800)	3.48 (11'5")	9.76 (32'0")	3.56 (11'8")	3.20 (10'7")	6.00 (19'8")	7.90 (25'11")	Front 29.5R25 Rear 33.25R29
D44	*	81-86	336 (450)	40.0 (44.0)	28 000 (61,600)	3.66 (12'0")	10.05 (33'0")	3.86 (12'8")	2.90 (9'6")	6.35 (20'10")	9.96 (32'8")	33.25R29
D44B	4LD	86-87	343 (460)	40.0 (44.0)	32 296 (71,200)	3.73 (12'3")	10.05 (33'0")	3.98 (13'1")	2.98 (9'9")	6.40 (21'0")	9.08 (29'9")	33.25R29
D250	*	75-78	175 (235)	25.0 (27.5)	18 500 (40,700)	2.66 (8'9")	8.82 (29'0")	3.04 (10'0")	2.61 (8'7")	6.22 (20'5")	7.67 (25'2")	23.5R25
D250B	5WD	85-91	163 (218)	22.7 (25.0)	17 963 (39,600)	2.50 (8'2.5")	9.60 (31'8.5")	3.18 (10'5")	2.55 (8'4.5")	6.23 (20'5")	7.65 (25'1")	20.5R25
D250D	6NG	92-94	160 (214)	22.8 (25.0)	17 300 (38,150)	2.50 (8'2")	9.60 (31'6")	3.21 (10'7")	2.59 (8'6")	6.22 (20'5")	7.61 (25'0")	20.5R25
D250E	5TN	95-98	194 (260)	22.7 (25.0)	20 135 (44,397)	2.74 (9'0")	9.94 (32'7")	3.35 (11'0")	2.7 (8'10")	6.2 (20'4")	7.44 (24'5")	23.5R25
D250E Series II	4PS	98-00	201 (270)	22.7 (25.0)	21 600 (47,628)	2.88 (9'5")	10.0 (32'10")	3.35 (11'0")	2.75 (9'0")	6.39 (20'11")	7.44 (24'5")	23.5R25
725	AFX	2000/05	209 (280)	23.6 (26)	22 730 (50,120)	2.88 (9'5")	9.92 (32'7")	3.44 (11'3")	2.75 (9'0")	6.43 (21'1")	7.26 (23'10")	23.5R25
D275	*	78-80	175 (235)	25.0 (27.5)	18 700 (41,000)	2.66 (8'9")	8.82 (29'0")	3.17 (10'7")	2.61 (8'7")	6.22 (20'5")	7.75 (25'3")	23.5R25
D275B	*	80-82	190 (255)	25.0 (27.5)	19 200 (42,400)	2.66 (8'9")	8.96 (29'5")	3.21 (10'7")	2.61 (8'7")	6.22 (20'5")	7.75 (25'5")	23.5R25

\*Information not available — DJB models.

## Articulated Trucks (cont'd)

Model	Product Ident. No. Prefix	Years Built	Flywheel Kilowatts (Horsepower)	Capacity Metric Tons (U.S. Tons)	Approx. Weight kg (lb)	Dimensions m (ft)						Tire Size
						Width	Length	Height	Loading Height	Dumping Height (55°)	Turning Circle	
D300	*	76-78	190 (255)	30.0 (33.0)	19 500 (42,900)	2.80 (9'2")	8.82 (29'0")	3.04 (10'0")	2.68 (8'10")	6.22 (20'5")	7.67 (25'2")	23.5R25
D300B	4SD	85-91	194 (260)	27.2 (30.0)	19 800 (43,520)	2.50 (8'2.5")	9.60 (31'8.5")	3.18 (10'5")	2.55 (8'4.5")	6.23 (20'5")	7.76 (25'6")	23.5R25
D300D	5MG	92-95	213 (285)	27.2 (30.0)	20 680 (45,600)	2.88 (9'6")	9.87 (32'5")	3.28 (10'9")	2.66 (8'9")	6.42 (21'1")	7.76 (25'5")	23.5R25
D300E	7FN	95-98	212 (285)	27.2 (30.0)	21 940 (48,369)	2.89 (9'6")	9.94 (32'7")	3.35 (11'0")	2.85 (9'4")	6.26 (20'6")	7.6 (24'10")	23.5R25
D300E Series II	5KS	98-00	212 (285)	27.2 (30.0)	22 793 (50,235)	2.91 (9'7")	10.0 (32'10")	3.35 (11'0")	2.89 (9'6")	6.44 (21'2")	7.6 (24'10")	23.5R25
730	AGF	2000/05	228 (305)	28.1 (31.5)	23 230 (51,222)	2.88 (9'5")	9.92 (32'7")	3.44 (11'3")	2.89 (9'6")	6.50 (21'4")	7.26 (23'10")	23.5R25
D330	*	78-80	190 (255)	30.0 (33.0)	20 000 (43,000)	2.80 (9'2")	8.82 (28'11")	3.17 (10'5")	2.68 (8'9")	6.22 (20'5")	7.80 (25'7")	23.5R25
D330B	*	80-83	190 (255)	30.0 (33.0)	20 200 (44,400)	2.76 (9'1")	9.08 (29'9")	3.25 (10'8")	2.68 (8'9")	6.33 (20'9")	7.92 (26'0")	23.5R25
D350	*	78-80	190 (255)	31.8 (35.0)	21 000 (46,000)	3.00 (9'10")	8.95 (29'4")	3.21 (10'7")	2.82 (9'3")	6.35 (20'10")	7.95 (26'1")	26.5R25
D350B	*	80-83	190 (255)	31.8 (35.0)	21 400 (47,200)	3.00 (9'10")	9.09 (29'10")	3.25 (10'8")	2.85 (9'4")	6.40 (21'0")	7.95 (26'1")	26.5R25
D350C	8XC	85-89	194 (260)	31.8 (35.0)	23 315 (51,400)	3.00 (9'10")	9.93 (32'7")	3.27 (10'9")	2.91 (9'6")	6.52 (21'5")	16.16 (53'0")	26.5R25
D350D	9RF	89-94	213 (285)	31.8 (35.0)	24 595 (54,221)	3.00 (9'10")	9.95 (32'7")	3.34 (11'0")	2.93 (9'7")	6.52 (21'5")	16.06 (52'8")	26.5R25
D350E	9LR	96-99	253 (340)	31.7 (35.0)	27 871 (61,455)	3.26 (10'8")	10.38 (34'1")	3.51 (11'6")	2.94 (9'8")	6.6 (21'8")	8.21 (26'11")	26.5R25
D350E Series II	2XW	99-01	265 (355)	31.8 (35.0)	30 190 (66,560)	3.26 (10'8")	10.65 (35'1")	3.51 (11'6")	2.92 (9'7")	6.83 (20'5")	8.45 (27'8")	26.5R25
735	AWR	2002/05	272 (365)	32.7 (36)	29 858 (65,825)	3.31 (10'10")	10.89 (35'9")	3.70 (12'2")	2.97 (9'10")	6.96 (22'10")	8.14 (26'9")	26.5R25
735	B1N	05-10	324 (435)	32.7 (36)	31 391 (69,206)	3.43 (11'3")	10.89 (35'7")	3.7 (12'1")	2.98 (9'8")	6.81 (22'3")	16.27 (53'4")	26.5R25
D400	IMD	85-89	287 (385)	36.3 (40.0)	25 765 (56,800)	3.00 (9'10")	10.42 (34'2")	3.45 (11'4")	3.00 (9'10")	6.53 (21'5")	16.07 (52'9")	26.5R25
D400D	8TF	89-95	287 (385)	36.3 (40.0)	28 027 (61,800)	3.30 (10'8")	10.62 (34'10")	3.56 (11'8")	2.98 (9'9")	6.60 (21'8")	8.26 (27'2")	29.5R25
D400E	2YR	96-99	302 (405)	36.3 (40.0)	29 263 (64,495)	3.3 (10'10")	10.52 (34'6")	3.58 (11'9")	3.07 (10'1")	6.58 (21'7")	8.26 (27'1")	29.5R25
D400E Series II	8PS	99-01	302 (405)	36.3 (40.0)	31 650 (69,760)	3.43 (11'2")	10.65 (35'1")	3.58 (11'9")	3.10 (10'2")	6.92 (23'0")	8.45 (27'8")	29.5R25
D400E II Ejector	APF	99-01	302 (405)	36.3 (40.0)	32 840 (72,380)	3.5 (11'6")	11.0 (36'1")	3.58 (11'9")	3.07 (10'1")	N/A	8.45 (27'8")	29.5R25
740	AXM	2001/05	309 (415)	38.1 (42)	32 693 (72,075)	3.43 (11'3")	10.89 (35'9")	3.75 (12'4")	3.18 (10'5")	7.07 (23'2")	8.14 (26'9")	29.5R25
740	B1P	05-10	350 (469)	39.5 (43.5)	33 100 (72,973)	3.52 (11'5")	10.89 (35'7")	3.75 (12'3")	3.24 (10'6")	7.09 (23'4")	16.27 (53'4")	29.5R25
740 Ejector	AZZ	2001/05	309 (415)	38.1 (42)	35 270 (77,770)	3.50 (11'6")	11.59 (38'0")	3.75 (12'4")	3.07 (10'0")	3.07 (10'0")	8.63 (28'4")	29.5R25
740 Ejector	B1R	05-10	350 (469)	42 (38)	35 610 (78,507)	3.52 (11'5")	11.59 (38'0")	3.75 (12'3")	3.07 (10'0")	— (53'4")	17.28 (53'4")	29.5R25
D550	*	78-86	336 (450)	50.0 (55.0)	37 800 (83,400)	3.66 (12'0")	11.35 (37'3")	3.86 (12'8")	3.30 (10'10")	7.83 (25'8")	9.65 (31'8")	33.25R29
D550B	8SD	86-87	343 (460)	50.0 (55.0)	40 370 (89,000)	3.72 (12'2.5")	11.74 (38'6")	3.97 (13'0")	3.22 (10'6")	8.28 (27'2")	8.73 (28'8")	33.25R29

\*Information not available — DJB models.



WHEEL DOZERS

Model	Product Ident. No. Prefix	Years Built	Flywheel Kilowatts (Horsepower)	Approx. Oper. Wt. kg (lb)	Length (Dozer on ground)		Wheelbase m (ft)	Ground Clearance mm (in)	Transmission	Maximum Speeds		
					Tread m (ft)	m (ft)				Fwd. km/h (mph)	Rev. km/h (mph)	
814B	90P	70-81	127 (170)	18 780 (41,400)	6.49 (21'3")	2.16 (7'1")	3.10 (10'2")	356 (14")	PS 4F-4R	32.7 (20.3)	39.3 (24.4)	*
814B	16Z	81-95	161 (216)	20 927 (46,137)	6.82 (22'5")			459 (18")	PS 4F-4R	29.9 (18.6)	34.1 (21.2)	*
814F	9DM	96-02	164 (220)	22 780 (50,115)		2.2 (7'3")	3.35 (11'0")	448 (18")	PS 4F-4R	29.9 (18.6)	34.1 (21.2)	
814F	BGF	03-06	179 (240)	21 713 (47,877)	6.82 (22'5")	2.2 (7'3")	3.35 (11'0")	448 (18")	PS 4F-4R	29.9 (18.6)	34.1 (21.2)	
814F II	BXG	06	173 (232)	20 755 (45,765)	6.9 (22'6")	2.2 (7'3")	3.6 (11'8")	366 (12")	PS 4F-4R	31 (19.3)	34.9 (21.8)	
824	29G	63-65	224 (300)	31 700 (70,000)	7.04 (23'1")	2.37 (7'10")	3.35 (11'8")	470 (18.2")	PS 3F-3R	34.1 (21.2)	34.1 (21.2)	
824B	36H	65-78	224 (300)	33 330 (73,480)	7.40 (24'3.5")	2.32 (7'7.5")	3.55 (11'8")	490 (19.4")	PS 3F-3R	29.8 (18.5)	29.8 (18.5)	
824C	85X	78-95	235 (315)	30 380 (66,975)	7.69 (25'2")	2.36 (7'7.5")	3.53 (11'7")	477 (18.8")	PS 4F-4R	33.2 (20.6)	37.8 (23.5)	
824G	4SN	96-02	235 (315)	26 620 (58,697)	8.02 (26'4")	2.44 (8'0")	3.7 (12'2")	383 (15")	PS 4F-4R	33 (20.4)	37.8 (23.5)	
824G II	AXB	03-04	253 (339)	28 724 (63,325)	8.02 (26'4")	2.44 (8'0")	3.7 (12'2")	383 (15")	PS 4F-4R	32.1 (20)	36.6 (22.7)	
824H	ASX	05	264 (354)	28 724 (63,325)	8.2 (26'9")	2.44 (8'0")	3.7 (12'2")	358 (12")	PS 4F-4R	32.1 (20)	36.6 (22.7)	
834	43E	63-74	298 (400)	40 300 (88,800)	7.75 (25'5")	2.54 (8'4")	3.80 (12'6")	510 (20.0")	PS 3F-3R	32.8 (20.4)	35.7 (22.2)	
834B	7BR	74-00	336 (450)	46 350 (102,200)	8.72 (28'7")			466 (18")	PS 4F-4R	34.1 (21.2)	41.8 (25.9)	
834G	6GZ	98-01	359 (481)	44 680 (98,500)	10.4 (34'2")	2.59 (8'6")	4.55 (14'11")	541 (21")	PS 4F-3R	38.5 (23.9)	23.0 (14.3)	**
834G	BPC	02-04	359 (481)	47 106 (103,849)	10.4 (34'2")	2.59 (8'6")	4.55 (14'11")	541 (21")	PS 4F-3R	38.5 (23.9)	23.0 (14.3)	
834H	BTX	05	372 (489)	47 106 (103,849)	10.42 (34'2")	2.59 (8'6")	4.55 (14'11")	531 (19")	PS 4F-3R	35.4 (22)	21.4 (13.3)	
844	2KZ	98-01	466 (625)	69 230 (152,620)	10.9 (35'9")	3.1 (10'0")	4.6 (15'1")	552 (22")	PS 3F-3R	22.5 (14.0)	25.0 (15.5)	***
844	BBN	01-05	466 (625)	70 815 (156,120)	10.9 (35'9")	3.1 (10'0")	4.6 (15'1")	552 (22")	PS 3F-3R	22.5 (14.0)	25.0 (15.5)	
844H	BTW	05	468 (627)	70 815 (156,120)	10.94 (35'9")	3.1 (10'0")	4.6 (15'1")	475 (17")	PS 3F-3R	21 (13)	23 (14.3)	
854G	1JW	97-99	597 (800)	99 400 (219,125)	13.4 (44'0")	3.3 (10'10")	5.89 (19'3")	691 (27")	PS 3F-3R	20.5 (12.7)	22.7 (14.1)	****
854G	AMP	00-04	597 (800)	99 400 (219,125)	13.4 (44'0")	3.3 (10'10")	5.39 (19'3")	691 (27")	PS 3F-3R	20.5 (12.7)	22.7 (14.1)	
854K	221	08	597 (801)	98 100 (216,273)	13.45 (44'0")	3.3 (10'10")	5.89 (19'3")	691 (27")	PS 3F-3R	21.2 (13.2)	23.5 (14.6)	

\*Turbocharged, Articulated Steering.

\*\*Move to "G" Series.

\*\*\*New model from Tiger (590).

\*\*\*\*New model from Tiger (790).



## COMPACTORS

Model	Product Ident. No. Prefix	Years Built	Flywheel Kilowatts (Horsepower)	Approx. Oper. Wt. kg (lb)	Drum Width m (ft)	Articulated Steering Angle, Maximum	Transmission	Maximum Speeds Fwd. km/h (mph)	Rev. km/h (mph)	
815	91P	70-81	127 (170)	17 300 (38,200)	0.97 (3'2")	44° Either Side	Power Shift 4F-4R	30.1 (18.7)	35.7 (22.2)	*
815B	17Z	81-95	161 (216)	20 035 (44,175)	0.98 (3'2")	45° Either Side	Power Shift 4F-4R	37.5 (23.3)	42.9 (26.6)	*
815F	1GN	96-02	164 (220)	20 952 (46,096)	0.98 (3'2")	36° Either Side	Power Shift 4F-4R	37.6 (23.3)	43.0 (26.7)	
815F	BKL	03-06	179 (240)	20 755 (45,765)	0.98 (3'2")	36° Either Side	Power Shift 3F-3R	17.9 (11.1)	19.5 (12.1)	
815F II	BYN	06	173 (232)	20 755 (45,756)	0.99 (3'3")	42° Either side	Power Shift 3F-3R	17.6 (11)	19.5 (12.2)	
816	57U	72-81	127 (170)	18 550 (40,900)	1.02 (3'4")	44° Either Side	Power Shift 4F-4R	30.1 (18.6)	35.7 (22.4)	**
816B	15Z	81-95	161 (216)	20 628 (45,477)	1.02 (3'4")		Power Shift 4F-4R	35.3 (22.0)	40.4 (25.1)	**
816F	5FN	96-02	164 (220)	20 879 (45,934)	1.02 (3'4")	42° Either Side	Power Shift 4F-4R	36.3 (22.5)	41.4 (25.7)	
816F II	BZR	06	173 (232)	23 748 (52,364)	1.016 (3'4")	42° Either side	Power Shift 2F-2R	9.5 (5.9)	10.6 (6.6)	
825B	43N	70-78	224 (300)	30 075 (66,300)	1.13 (3'8")	44° Either Side	Power Shift	29.8 (18.5)	29.8 (18.5)	
825C	86X	78-96	231 (310)	32 400 (71,432)	1.13 (3'8")	42° Either Side	Power Shift 4F-4R	29.8 (18.5)	33.9 (21.1)	
825G	6RN	96-02	235 (315)	31 740 (69,828)	1.13 (3'8")	42° Either Side	Power Shift 3F-3R	15.6 (9.7)	17.2 (10.7)	
825G II	AXB	03-04	253 (339)	32 734 (72,164)	1.13 (3'8")	42° Either Side	Power Shift 3F-3R	15.6 (9.7)	17.2 (10.7)	
825H	AZW	05	264 (354)	32 734 (72,164)	1.125 (3'7")	42° Either side	Power Shift 3F-3R	15.6 (9.7)	17.2 (10.7)	
826C	87X	78-95	235 (315)	34 920 (76,990)	1.20 (3'11")	42° Either Side	Power Shift 4F-4R	32.5 (20.2)	37.2 (23.1)	
826G	7LN	96-02	235 (315)	33 350 (73,537)	1.2 (3'11")	42° Either Side	Power Shift 2F-2R	11.2 (6.9)	13.5 (8.4)	
826H	AWF	05	264 (354)	36 967 (81,498)	1.2 (3'11")	42° Either side	Power Shift 2F-2R	9.7 (6.03)	10.6 (6.59)	
835	44N	70-74	298 (400)	35 900 (79,100)	1.22 (4'0")	44° Either Side	Power Shift 3F-3R	32.2 (20.0)	34.8 (21.6)	
836	3RL	93-95	336 (450)	45 450 (100,000)	1.4 (4'7")	35° Either Side	Power Shift 2F-2R	11.3 (7.0)	14.0 (8.7)	*
836G	7MZ	98-01	351 (471)	53 680 (118,348)	1.4 (4'7")	35° Either Side	Power Shift 2F-2R	6.0 (3.7)	10.2 (6.3)	
836H	BXD	05	372 (499)	53 682 (118,348)	1.4 (4'7")	35° Either side	Power Shift 2F-2R	10.9 (6.8)	11.4 (7.1)	

\*Turbocharged, Articulated Steering.

\*\*Turbocharged, ROPS Cab, Sleeve Metering Fuel System.



WHEEL LOADERS

Model	Product Ident. No. Prefix	Years Built	Flywheel Horse-power	Approx. Shipping Wt. kg (lb)	Rated Capacity m <sup>3</sup> (yd <sup>3</sup> )	Breakout Force kg (lb)	Width Over Tires m (ft)	Ground Clearance mm (in)	Max. Reach at max. height mm (ft)	Dump Clearance at max. height m (ft)	Maximum Speeds km/h (mph)		Remarks
											Fwd.	Rev.	
904B	B4L	05-08	52	4368 (9630)	0.6 (0.8)	3633 (8009)	1.7 (5'7")	218 (8.6")	664 (2'2")	2.38 (7'10")	20 (12.4)	20 (12.4)	
910	80V	73-79	65	6100 (13,400)	1.0 (1.25)	4530 (10,000)	2.07 (6'10")	405 (16")	860 (2'10")	2.46 (8'1")	24.1 (15.0)	10.6 (6.6)	
910	40Y	79-89	65	6658 (14,679)	1.0 (1.25)	5838 (12,870)	2.07 (6'10")	405 (16")	930 (3'0.6")	2.40 (7'10")	23.9 (14.8)	10.6 (6.6)	
910	41Y	79-89	65	6658 (14,679)	1.0 (1.25)	5838 (12,870)	2.07 (6'10")	405 (16")	930 (3'0.6")	2.40 (7'10")	23.5 (14.6)	24.9 (15.5)	
910E	1SF	89-92	78	7298 (16,062)	1.3 (1.7)	6503 (14,339)	2.15 (7'0")	343 (13.5")	1000 (3'3.4")	2.57 (8'5")	34.0 (21.1)	22.4 (13.9)	3114 Engine Z Bar Linkage
910F	1SF	92-95	80	7009 (15,452)	1.3 (1.7)	6443 (14,207)	2.15 (7'0")	370 (14.6")	981 (3'3")	2.60 (8'6")	34.0 (21.1)	22.4 (13.9)	3114 Engine Z Bar Linkage
916	2XB	86-92	85	8554 (18,857)	1.4 (1.75)	9124 (20,115)	2.33 (7'8")	322 (12.7")	926 (3'0.5")	2.65 (8'9")	24.8 (15.4)	25.0 (15.5)	3204 Engine Z Bar Linkage
918F	3TJ	92-94	98	8973 (19,785)	1.5 (2.0)	9795 (21,598)	2.33 (91.6")	318 (13")	802 (2'8")	2.78 (9'1")	37.0 (23.0)	24.5 (15.2)	3114 Engine Z Bar Linkage
920	62K	69-84	80	8440 (18,600)	1.2 (1.5)	7901 (17,419)	2.16 (7'1")	335 (13")	740 (2'5")	2.77 (9'1")	43.8 (27.2)	23.2 (14.4)	
922A	59A	60-62	80	7350 (16,200)	0.93 (1.25)	6850 (15,100)	2.12 (7'0")	368 (15")	655 (2'2")	2.60 (8'7")	30.4 (18.9)	32.8 (20.4)	
922B	88J	62-68	80	7670 (16,900)	1.15 (1.50)	9000 (19,900)	2.25 (7'5")	390 (16")	680 (2'3")	2.60 (8'7")	33.6 (20.9)	42.9 (26.7)	
924F	5NN	94-99	105	9025 (19,900)	1.7 (2.25)	9553 (21,067)	2.33 (7'6")	318 (12.5")	855 (2'8")	2.70 (8'10")	38.2 (23.6)	23.6 (14.8)	
924G	9SW	99-02	120	9615 (21,197)	1.8 (2.3)	9876 (21,772)	2.36 (7'9")	370 (15)	1318 (4'4")	2.828 (9'4")	38.5 (23.9)	21.8 (13.5)	
924G	3PZ	99-02	120	9615 (21,197)	1.8 (2.3)	9876 (21,772)	2.36 (7'9")	370 (15)	1318 (4'4")	2.828 (9'4")	38.5 (23.9)	21.8 (13.5)	
924G	AAN	99-02	120	9615 (21,197)	1.8 (2.3)	9876 (21,772)	2.36 (7'9")	370 (15)	1318 (4'4")	2.828 (9'4")	38.5 (23.9)	21.8 (13.5)	
924G	DDA	02-07	129	9977 (21,996)	1.8 (2.3)	11 452 (25,247)	2.36 (7'9")	370 (15)	1451 (4'10")	2.918 (9'7")	38.5 (23.9)	21.8 (13.5)	
924G	RBB	02-07	129	9977 (21,996)	1.8 (2.3)	11 452 (25,247)	2.36 (7'9")	370 (15)	1451 (4'10")	2.918 (9'7")	38.5 (23.9)	21.8 (13.5)	
924G	WMB	02-07	129	9977 (21,996)	1.8 (2.3)	11 452 (25,247)	2.36 (7'9")	370 (15)	1451 (4'10")	2.918 (9'7")	38.5 (23.9)	21.8 (13.5)	
924Gz	6YW	99-02	120	9615 (21,197)	1.8 (2.3)	9876 (21,772)	2.36 (7'9")	370 (15)	1318 (4'4")	2.828 (9'4")	38.5 (23.9)	21.8 (13.5)	
924Gz	3DZ	99-03	120	9615 (21,197)	1.8 (2.3)	9876 (21,772)	2.36 (7'9")	370 (15)	1318 (4'4")	2.828 (9'4")	38.5 (23.9)	21.8 (13.5)	
924Gz	AAB	99-04	120	9615 (21,197)	1.8 (2.3)	9876 (21,772)	2.36 (7'9")	370 (15)	1318 (4'4")	2.828 (9'4")	38.5 (23.9)	21.8 (13.5)	
924Gz	DFZ	02-04	129	9615 (21,197)	1.8 (2.3)	9876 (21,772)	2.36 (7'9")	370 (15)	1318 (4'4")	2.828 (9'4")	38.5 (23.9)	21.8 (13.5)	
924Gz	RTA	02-07	129	9615 (21,197)	1.8 (2.3)	9876 (21,772)	2.36 (7'9")	370 (15)	1318 (4'4")	2.828 (9'4")	38.5 (23.9)	21.8 (13.5)	
924Gz	WGX	02-07	129	9615 (21,197)	1.8 (2.3)	9876 (21,772)	2.36 (7'9")	370 (15)	1318 (4'4")	2.828 (9'4")	38.5 (23.9)	21.8 (13.5)	

## Wheel Loaders (cont'd)

Model	Product Ident. No. Prefix	Years Built	Flywheel Horse-power	Approx. Shipping Wt. kg (lb)	Rated Capacity m <sup>3</sup> (yd <sup>3</sup> )	Breakout Force kg (lb)	Width Over Tires m (ft)	Ground Clearance mm (in)	Max. Reach at max. height mm (ft)	Dump Clearance at max. height m (ft)	Maximum Speeds km/h (mph)		Remarks
											Fwd.	Rev.	
926	94Z	84-87	105	8800 (19,400)	1.21 (1.75)	5070 (11,179)	2.33 (7'8")	341 (13.5")	924 (3'0")	2.67 (8'9")	30.3 (18.8)	32.3 (20.0)	3204 Engine Z Bar Linkage
926E	94Z	87-92	110	9432 (20,794)	1.7 (2.25)	10 044 (22,143)	2.33 (7'8")	341 (13.5")	1003 (3'3.5")	2.75 (9'0")	34.2 (21.2)	36.8 (22.9)	
928F	2XL	93-96	120	10 870 (23,920)	2.1 (2.75)	10 090 (22,200)	2.43 (8'0")	318 (13")	956 (3'2")	2.74 (9'0")	36.5 (22.6)	21.1 (13.1)	3116 Engine Z Bar Linkage
928G	6XR	96-02	125	11 250 (24,802)	2.0 (2.6)	11 723 (25,849)	2.44 (8'0")	408 (16")	1455 (4'9")	2.879 (9'5")	37.7 (23.4)	25.8 (16)	
928G	7SR	96-02	125	11 250 (24,802)	2.0 (2.6)	11 723 (25,849)	2.44 (8'0")	408 (16")	1455 (4'9")	2.879 (9'5")	37.7 (23.4)	25.8 (16)	
928Gz	DJD	02-07	143	11 250 (24,802)	2.0 (2.6)	11 723 (25,849)	2.44 (8'0")	408 (16")	1455 (4'9")	2.879 (9'5")	37.7 (23.4)	25.8 (16)	
928Gz	WLG	02-07	143	11 250 (24,802)	2.0 (2.6)	11 723 (25,849)	2.44 (8'0")	408 (16")	1455 (4'9")	2.879 (9'5")	37.7 (23.4)	25.8 (16)	
930	41K	68-85	100	9660 (21,300)	1.7 (2.25)	7900 (17,410)	2.39 (7'10")	348 (13.7")	1350 (3'9")	2.79 (9'2")	44.2 (27.5)	23.3 (14.5)	
930G	TWR	05-07	149	12 756 (28,122)	2.3 (3.0)	14 567 (32,115)	2.41 (7'11")	421 (16")	1542 (5'1")	2917 (9'7")	38.3 (23.8)	24.1 (15)	
930G	TFR	05-07	149	12 756 (28,122)	2.3 (3.0)	14 567 (32,115)	2.41 (7'11")	421 (16")	1542 (5'1")	2917 (9'7")	38.3 (23.8)	24.1 (15)	
936	33Z	83-87	125	11 884 (26,200)	2.1 (2.75)	12 514 (28,708)	2.56 (8'4.5")	329 (13")	1055 (3'0")	2.80 (9'2")	34.4 (21.4)	38.4 (23.9)	3304 Engine Box Frame
936E	33Z	87-92	135	12 300 (27,000)	2.3 (3.00)	12 920 (28,483)	2.56 (8'5")	379 (14.9")	1026 (2'11")	2.87 (9'2")	40.6 (25.2)	45.3 (28.2)	
936F	8AJ	92-94	140	12 300 (27,060)	2.3 (3.00)	12 920 (28,483)	2.58 (8'5")	379 (14.9")	997 (3'3")	2.84 (9'4")	42.3 (26.3)	46.7 (29.6)	
938F		94-97	140	13 030 (28,730)	2.5 (3.25)	12 330 (27,180)	2.61 (8'7")	400 (16")	1004 (3'4")	2.85 (9'4")	37.9 (23.6)	22.0 (13.7)	3116 Engine Wet Disc Brakes Z Bar Linkage
938G	4YS	97-02	160	12 962 (28,578)	2.8 (3.65)	11 227 (24,770)	2.60 (8'6")	400 (16")	1055 (3'6")	2.72 (8'11")	39.4 (24.5)	23.4 (14.5)	
938G Series II	CRD	02-07	160	13 452 (29,656)	2.8 (3.66)	11 156 (24,594)	2.6 (102)	400 (16)	1068 (42)	2771 (109)	38.8 (24.1)	23.3 (14.5)	
944	87J	59-68	100	10 100 (22,000)	1.53 (2.0)	9800 (21,700)	2.40 (7'10")	450 (18")	905 (3'0")	2.96 (9'9")	38.5 (23.9)	46.6 (28.9)	
950	81J	68-81	130	12 930 (28,500)	1.53 (2.07)	10 320 (22,760)	2.41 (7'11")	381 (15")	740 (2'5")	2.82 (9'3")	35.9 (22.3)	42.5 (26.4)	Articulated Steering, 4 Wheel Drive Z Bar Linkage
950B	22Z	81-87	155	14 650 (32,300)	2.9 (3.75)	15 680 (35,895)	2.67 (5'9")	427 (16.8")	1125 (3'8")	2.95 (9'8")	36.4 (22.6)	39.4 (24.5)	
950E	22Z	87-91	160	15 856 (34,883)	3.1 (4.0)	13 586 (29,925)	2.76 (9'0")	400 (15.7")	1160 (3'10")	2.85 (9'4")	36.2 (22.4)	39.9 (24.7)	23.5-25 Std. Tires
950F	7ZF	90-92	170	16 086 (35,463)	3.1 (4.0)	14 954 (32,974)	2.76 (9'0")	474 (18.7")	1160 (3'10")	2.85 (9'4")	39.3 (24.4)	43.0 (26.7)	3116 Engine Wet Disc Brakes Integral ROPS Electronic Shift
950F Series II	5SK	93-98	170	16 880 (37,220)	3.1 (4.0)	14 960 (32,980)	2.76 (9'0")	460 (18.1")	1180 (3'10")	2.83 (9'3")	38.7 (24.0)	42.7 (26.5)	
950G	3JW 4BS	98-02	183	16 904 (37,266)	3.5 (4.5)	14 888 (32,810)	2.89 (9'6")	400 (16")	1270 (4'2")	2.89 (9'6")	37.0 (23.0)	40.7 (25.3)	

Wheel Loaders (cont'd)

Model	Product Ident. No. Prefix	Years Built	Flywheel Horse-power	Approx. Shipping Wt. kg (lb)	Rated Capacity m <sup>3</sup> (yd <sup>3</sup> )	Breakout Force kg (lb)	Width Over Tires m (ft)	Ground Clearance mm (in)	Max. Reach at max. height mm (ft)	Dump Clearance at max. height m (ft)	Maximum Speeds km/h (mph)		Remarks
											Fwd.	Rev.	
960F	9ZJ	94-98	200	18 070 <b>(39,840)</b>	3.5 <b>(4.5)</b>	14 500 <b>(31,970)</b>	2.77 <b>(9'1")</b>	454 <b>(17.9")</b>	1030 <b>(3'5")</b>	2.92 <b>(9'6")</b>	39.4 <b>(24.5)</b>	43.2 <b>(26.8)</b>	Material Handler
962G	4PW 5AS	98-02	200	17 941 <b>(39,553)</b>	3.8 <b>(5.0)</b>	14 480 <b>(31,950)</b>	2.90 <b>(9'8")</b>	400 <b>(16")</b>	1250 <b>(4'2")</b>	2.77 <b>(9'2")</b>	37.0 <b>(23.0)</b>	40.7 <b>(25.3)</b>	
966A	33A	60-63	140	13 060 <b>(28,800)</b>	2.10 <b>(2.75)</b>	13 470 <b>(29,700)</b>	2.70 <b>(8'10")</b>	450 <b>(18")</b>	900 <b>(3'0")</b>	2.95 <b>(9'8")</b>	43.0 <b>(26.7)</b>	51.5 <b>(32.3)</b>	
966B	75A	63-68	150	14 300 <b>(31,500)</b>	2.29 <b>(3.0)</b>	14 000 <b>(31,000)</b>	2.70 <b>(8'10")</b>	400 <b>(16")</b>	900 <b>(3'0")</b>	2.95 <b>(9'8")</b>	38.5 <b>(23.9)</b>	46.3 <b>(28.8)</b>	
966C	76J	68-81	170	16 730 <b>(36,890)</b>	3.1 <b>(4.0)</b>	11 600 <b>(25,578)</b>	2.77 <b>(9'1")</b>	400 <b>(15.7")</b>	1420 <b>(4'8")</b>	2.95 <b>(9'8")</b>	38.0 <b>(23.6)</b>	45.1 <b>(28.0)</b>	3306 Engine
966D	99Y	80-87	200	19 730 <b>(43,500)</b>	3.3 <b>(4.25)</b>	20 972 <b>(48,150)</b>	2.86 <b>(9'4.8")</b>	451 <b>(17.8")</b>	1230 <b>(4'0")</b>	3.14 <b>(10'3.5")</b>	34.3 <b>(21.3)</b>	38.1 <b>(23.7)</b>	3306 Engine Z Bar Linkage
966E	99Y	87-90	216	20 324 <b>(44,767)</b>	3.8 <b>(5.0)</b>	18 939 <b>(41,715)</b>	2.94 <b>(9'8")</b>	476 <b>(18.7")</b>	1290 <b>(4'3")</b>	2.97 <b>(9'9")</b>	38.2 <b>(23.7)</b>	43.6 <b>(27.0)</b>	26.5-25 Std. Tires
966F	4YG	90-93	220	20 466 <b>(45,119)</b>	3.8 <b>(5.0)</b>	20 493 <b>(45,187)</b>	2.94 <b>(9'8")</b>	476 <b>(18.7")</b>	1280 <b>(4'2")</b>	2.98 <b>(9'9")</b>	37.6 <b>(23.4)</b>	42.6 <b>(26.4)</b>	Wet Disc Brakes
966F Series II	1SL	93-98	220	21 290 <b>(46,950)</b>	3.8 <b>(5.0)</b>	20 490 <b>(45,180)</b>	2.94 <b>(9'8")</b>	476 <b>(18.7")</b>	1277 <b>(4'2")</b>	2.98 <b>(9'9")</b>	38.8 <b>(24.1)</b>	43.9 <b>(27.3)</b>	Integral ROPS Electronic Shift
966G	3SW 3ZS	98-02	235	22 068 <b>(48,651)</b>	4.0 <b>(5.25)</b>	19 986 <b>(44,120)</b>	2.97 <b>(9'9")</b>	565 <b>(22")</b>	1295 <b>(4'3")</b>	3.1 <b>(10'2")</b>	37.1 <b>(23.1)</b>	42.2 <b>(26.2)</b>	
970F	7SK	93-98	250	23 690 <b>(52,240)</b>	4.7 <b>(6.0)</b>	16 510 <b>(36,400)</b>	2.94 <b>(9'8")</b>	482 <b>(19")</b>	1357 <b>(4'5")</b>	3.22 <b>(10'6")</b>	37.3 <b>(23.2)</b>	42.7 <b>(26.5)</b>	Material Handler New Model
972G	4WW 7LS	98-02	265	24 468 <b>(53,942)</b>	4.7 <b>(6.0)</b>	21 618 <b>(47,580)</b>	2.97 <b>(9'9")</b>	565 <b>(22")</b>	1255 <b>(4'1")</b>	3.15 <b>(10'4")</b>	37.0 <b>(22.9)</b>	41.9 <b>(26.0)</b>	
980	42H	66-70	235	20 000 <b>(44,000)</b>	3.06 <b>(4.0)</b>	18 860 <b>(41,570)</b>	2.87 <b>(9'5")</b>	399 <b>(16")</b>	1190 <b>(3'11")</b>	3.07 <b>(10'1")</b>	42.0 <b>(26.1)</b>	26.7 <b>(16.6)</b>	
980B	89P	70-78	260	23 360 <b>(51,500)</b>	3.44-4.21 <b>(4.5-5.5)</b>	15 900 <b>(35,100)</b>	3.11 <b>(10'2")</b>	— <b>(—)</b>	1120 <b>(3'8")</b>	3.20 <b>(10'6")</b>	43.0 <b>(26.7)</b>	27.4 <b>(17.0)</b>	
980C	63X	79-91	270	27 559 <b>(60,755)</b>	5.2 <b>(6.75)</b>	23 188 <b>(51,121)</b>	3.15 <b>(10'4")</b>	417 <b>(16.4")</b>	1480 <b>(4'10")</b>	3.19 <b>(10'6")</b>	34.6 <b>(21.5)</b>	39.6 <b>(24.5)</b>	Dual Z Bar Linkage
980F 980F Series II	8CJ	91-92 92-95	275	27 580 <b>(60,800)</b>	5.3 <b>(7.0)</b>	23 188 <b>(51,121)</b>	3.15 <b>(10'4")</b>	469 <b>(18.5")</b>	1500 <b>(4'11")</b>	3.16 <b>(10'5")</b>	37.4 <b>(23.2)</b>	42.8 <b>(26.6)</b>	Electronic Shift
980G	2KR	95-01	300	29 480 <b>(65,000)</b>	5.4 <b>(7.0)</b>	23 760 <b>(52,390)</b>	3.25 <b>(10'8")</b>	467 <b>(18.4")</b>	1540 <b>(5'1")</b>	3.27 <b>(10'8")</b>	37.4 <b>(23.2)</b>	42.8 <b>(26.6)</b>	

## Wheel Loaders (cont'd)

Model	Product Ident. No. Prefix	Years Built	Flywheel Horse-power	Approx. Shipping Wt. kg (lb)	Rated Capacity m <sup>3</sup> (yd <sup>3</sup> )	Breakout Force kg (lb)	Width Over Tires m (ft)	Ground Clearance mm (in)	Max. Reach at max. height mm (ft)	Dump Clearance at max. height m (ft)	Maximum Speeds km/h (mph)		Remarks
											Fwd.	Rev.	
988	87A	63-76	325	35 800 (79,000)	4.6-5.4 (6.0-7.0)	21 380 (47,130)	3.20 (10'7")	570 (22.5")	1450 (4'9")	3.33 (10'11")	30.6 (19.0)	30.6 (19.0)	
988B	50W	76-93	375	43 365 (95,600)	5.4-6.3 (7.0-8.25)	36 330 (80,100)	3.52 (11'7")	474 (18")	2150 (7'1")	3.19 (10'5")	36.2 (22.5)	41.4 (25.7)	3408 Engine Z Bar Linkage
988F	8YG	93-95	400	43 540 (95,900)	5.4-6.1 (7.0-8.0)	37 363 (82,371)	3.52 (11'7")	496 (19")	1830 (6'0")	3.21 (10'6")	35.1 (21.8)	23.5 (14.6)	Bucket/HP increase STIC Steer
988F Series II	2ZR	95-00	475	45 678 (100,492)	6.1-6.9 (8.0-9.0)	37 400 (82,282)	3.52 (11'7")	496 (1'7")	1611 (5'3")	3.22 (10'7")	35.1 (21.8)	23.5 (14.6)	3048E HEUI Engine Axle Shaft Brakes
988G	2TW	01	475	50 040 (110,320)	6.3-7.0 (8.2-9.2)	46 950 (103,500)	3.47 (11'5")	549 (21.6")	2113 (6'11")	4.0 (13'1")	38.7 (24.0)	22.3 (13.8)	6 Bar Linkage "G" Series
988G	BNH	01-05	475	50 040 (110,320)	6.3-7.0 (8.2-9.2)	46 950 (103,500)	3.47 (11'5")	549 (21.6")	2113 (6'11")	4.0 (13'1")	38.6 (24.0)	25.1 (15.6)	6 Bar Linkage "G" Series
988H	BXY	05	501	49 546 (109,249)	6.4-7.0 (8.33-9.2)	378.4 (85,068)	3.47 (11'5")	549 (22")	5.85 (19'2")	3466 (11'37")	36 (22.3)	23.7 (14.7)	3.88 Meter Linkage
990	7HK	93-95	610	72 910 (160,600)	8.6 (11.2)	59 776 (131,784)	4.13 (13'6")	552 (21.7")	2070 (6'10")	3.99 (13'1")	22.5 (14.0)	25.0 (15.5)	ICTC & New Model
990 Series II	4FR	96-05	625	72 200 (159,170)	8.4-9.2 (11-12)	63 100 (138,800)	4.0 (13'1")	490 (19.3")	1990 (6'6")	4.05 (13'3")	22.5 (14.0)	25.0 (15.5)	HEUI Engine
990H	BWX	05	627	77 842 (171,642)	8.6-9.2 (11.25-12)	602 (135,429)	4.16 (13'3")	478 (18'8")	8.07 (26'6")	4220 (13'10")	22.4 (13.92)	24.8 (15.41)	Standard Lift 8.6 m <sup>3</sup> /11.2 yd <sup>3</sup> Bucket
992	25K	68-73	550	47 670 (105,100)	7.65 (10.0)	36 900 (81,360)	3.93 (12'11")	530 (21")	2820 (8'3")	4.52 (14'10")	35.6 (22.1)	38.5 (23.8)	
992B	25K	73-77	550	64 320 (141,800)	7.65 (10.0)	29 330 (84,660)	— —	— —	1930 (6'4")	4.34 (14'3")	40.2 (25.0)	43.6 (27.1)	
992C	42X	77-81	690	85 640 (188,800)	9.6 (12.5)	66 240 (146,030)	4.55 (14'11")	533 (21")	2310 (7'7")	4.17 (13'8")	21.1 (13.1)	23.3 (14.5)	3412 PCT Engine Z Bar Linkage
992C	49Z	81-92	690	88 430 (194,950)	10.4 (13.5)	66 285 (146,132)	4.50 (14'9")	544 (21")	2310 (7'7")	4.17 (13'8")	21.0 (13.0)	22.9 (14.2)	3412 DIT Engine
992D	7MJ	92-97	710	88 690 (195,125)	10.7 (14.0)	62 670 (137,870)	4.50 (14'9")	544 (21")	2300 (7'7")	4.17 (13'8")	21.0 (13.0)	22.9 (14.2)	
992G	7HR	98-00	800	91 540 (201,810)	11.5-12.3 (15-16)	62 650 (137,840)	4.5 (14'9")	691 (27.2")	2300 (7'7")	4.6 (15'3")	20.2 (12.5)	22.7 (14.1)	6 Bar Linkage "G" Series
992K	H4C	07	801	97 294 (214,535)	10.7-12.3 (14-16)	584.66 (128,917)	— —	682 (2'2")	9313 (30'6")	4480 (14'8")	20.6 (12.8)	22.4 (13.9)	10.7 m <sup>3</sup> /14 yd <sup>3</sup> Bucket
993K	Z9K	07	945	133 637 (294,800)	12.8-14.5 (16.7-19)	709 (159,500)	4.93 (16'2")	783 (30'8")	9313 (30'7")	4849 (15'11")	20.1 (12.5)	12.5 (7.8)	12.8 m <sup>3</sup> /16.7 yd <sup>3</sup> Bucket
994	9YF	90-98	1250	177 000 (390,300)	10.3 (13.4)	103 420 (228,000)	5.20 (17'1")	662 (26")	2692 (8'10")	6.20 (20'4")	24.7 (15.0)	26.6 (16.5)	





## TRACK LOADERS

Model	Product Ident. No. Prefix	Years Built	Flywheel Horsepower	Approx. Operating Weight kg (lb)	Rated Capacity m <sup>3</sup> (yd <sup>3</sup> )	Dimensions			Remarks
						Length** m (ft)	Width m (ft)	Height m (ft)	
931	78U	72-79	62	6940 <b>(15,300)</b>	0.77 <b>(1.0)</b>	2.74 <b>(9'0")</b>	1.78 <b>(5'10")</b>	1.96 <b>(6'5")</b>	
931 LGP	10N	75-79	62	7498 <b>(16,530)</b>	1.15 <b>(1.5)</b>	2.74 <b>(9'0")</b>	2.29 <b>(7'6")</b>	1.98 <b>(6'6")</b>	
931B	29Y	79-88	65	7362 <b>(16,230)</b>	0.8 <b>(1.0)</b>	4.13 <b>(13'9")</b>	1.84 <b>(6'0.5")</b>	2.68 <b>(8'10")</b>	
931B LGP	30Y	79-88	65	8089 <b>(17,834)</b>	0.8 <b>(1.0)</b>	3.84 <b>(12'7")</b>	2.41 <b>(7'11")</b>	2.68 <b>(8'10")</b>	
931C	2BJ1 7HF		67	7595 <b>(16,743)</b>	0.77 <b>(1.0)</b>	2.74 <b>(9'0")</b>	1.78 <b>(5'10")</b>	2.68 <b>(8'10")</b>	
931C LGP	6RF1 8AF		67	8170 <b>(18,012)</b>	0.77 <b>(1.0)</b>	2.74 <b>(9'0")</b>	1.78 <b>(5'10")</b>	2.68 <b>(8'10")</b>	
931C Series II	9AG 6AJ	90-93	70	8047 <b>(17,742)</b>	0.83 <b>(1.08)</b>	4.14 <b>(13'1")</b>	1.97 <b>(6'5")</b>	2.68 <b>(8'10")</b>	
933C	11A	55-58	50	7030 <b>(15,500)</b>	0.77 <b>(1.0)</b>	4.22 <b>(13'10")</b>	1.77 <b>(5'10")</b>	1.91 <b>(6'4")</b>	Integral loader
933E	11A	58-65	50	7640 <b>(16,850)</b>	0.77 <b>(1.0)</b>	4.22 <b>(13'10")</b>	1.77 <b>(5'10")</b>	1.40 <b>(6'3")</b>	Integral loader
933G	42A	65-68	60	7900 <b>(17,500)</b>	0.86 <b>(1.125)</b>	4.31 <b>(14'2")</b>	1.77 <b>(5'10")</b>	2.15 <b>(7'1")</b>	Patented Sealed Track
935B	30F	87-88	75	7899 <b>(17,414)</b>	1.0 <b>(1.25)</b>	4.19 <b>(13'9")</b>	1.96 <b>(6'5")</b>	2.68 <b>(8'10")</b>	
935C	8CF		78	8205 <b>(18,089)</b>	1.0 <b>(1.3)</b>	4.19 <b>(13'9")</b>	1.96 <b>(6'5")</b>	2.68 <b>(8'10")</b>	
935C Series II	SDJ	90-93	80	8759 <b>(19,311)</b>	1.0 <b>(1.3)</b>	4.37 <b>(14'4")</b>	1.97 <b>(6'5")</b>	2.68 <b>(8'10")</b>	
941	80H	68-72	70	8900 <b>(19,700)</b>	0.96 <b>(1.25)</b>	4.50 <b>(14'10")</b>	1.86 <b>(6'1")</b>	2.75 <b>(9'0")*</b>	Electric Start
941B	80H	68-81	80	11 294 <b>(24,900)</b>	1.15 <b>(1.5)</b>	4.50 <b>(14'10")</b>	1.98 <b>(6'6")</b>	2.75 <b>(9'0")*</b>	HP Increase, Hydraulic Track Adjusters
943	31Y	80-85	80	11 750 <b>(25,900)</b>	1.15 <b>(1.5)</b>	5.426 <b>(17'10")</b>	2.21 <b>(8'7")</b>	3.02 <b>(9'11")</b>	Hydrostatic drive
943	19Z	80-92	80	11 750 <b>(25,900)</b>	1.15 <b>(1.5)</b>	5.426 <b>(17'10")</b>	2.21 <b>(8'7")</b>	3.02 <b>(9'11")</b>	Hydrostatic drive made in France

\*Height to top of stack. Others to top of seat back.

\*\*Overall length to tip of smallest General Purpose bucket.

## Track Loaders (cont'd)

Model	Product Ident. No. Prefix	Years Built	Flywheel Horsepower	Approx. Operating Weight kg (lb)	Rated Capacity m <sup>3</sup> (yd <sup>3</sup> )	Dimensions			Remarks
						Length** m (ft)	Width m (ft)	Height m (ft)	
951B	79H	67-71	85	10 025 <b>(22,100)</b>	1.14 <b>(1.5)</b>	4.70 <b>(15'6")</b>	1.98 <b>(6'6")</b>	2.75 <b>(9'0")*</b>	Pedal Steering HP Increase, Sealed & Lubricated Track
951C	86J	71-81	95	12 338 <b>(27,200)</b>	1.34 <b>(1.75)</b>	4.77 <b>(15'8")</b>	1.98 <b>(6'6")</b>	2.75 <b>(9'0")*</b>	
953	5Z	81-85	110	14 050 <b>(31,000)</b>	1.5 <b>(2.0)</b>	5.87 <b>(19'3")</b>	2.38 <b>(7'10")</b>	3.08 <b>(10'1")</b>	Hydrostatic drive
953	20Z	81-92	110	14 050 <b>(31,000)</b>	1.5 <b>(2.0)</b>	5.87 <b>(19'3")</b>	2.38 <b>(7'10")</b>	3.08 <b>(10'1")</b>	Hydrostatic drive
953	76Y	81-85	110	13 800 <b>(30,500)</b>	1.5 <b>(2.0)</b>	5.87 <b>(19'3")</b>	2.38 <b>(7'10")</b>	3.08 <b>(10'1")</b>	Hydrostatic drive
953	77Y	81-85	110	13 800 <b>(30,500)</b>	1.5 <b>(2.0)</b>	5.87 <b>(19'3")</b>	2.38 <b>(7'10")</b>	3.08 <b>(10'1")</b>	Hydrostatic drive
953B	5MK	92-96	120	14 400 <b>(31,800)</b>	1.75 <b>(2.25)</b>	4.23 <b>(13'4")</b>	2.38 <b>(7'10")</b>	3.08 <b>(10'1")</b>	Hydrostatic drive
953C	2ZN	96-03	121	14 680 <b>(32,360)</b>	2.3 <b>(3.0)</b>	4.35 <b>(14'3")</b>	2.30 <b>(7'7")</b>	3.08 <b>(10'1")</b>	SystemOne U/C
953C Tier 2	BBX	03-07	128	15 145 <b>(33,389)</b>	1.75 <b>(2.25)</b>	4.35 <b>(14'3")</b>	2.30 <b>(7'7")</b>	3.16 <b>(10'4")</b>	
HT4	7U	50-55	54	2607 <b>(5748)</b>	0.96 <b>(1.25)</b>	4.32 <b>(14'2")</b>	2.03 <b>(6'8")</b>	1.83 <b>(6'0")</b>	Integral loader
955C	12A	55-60	70	9590 <b>(21,145)</b>	1.15 <b>(1.5)</b>	4.60 <b>(15'2")</b>	2.03 <b>(6'8")</b>	2.08 <b>(6'11")</b>	
955E	12A	58-60	70	10 160 <b>(22,400)</b>	1.15 <b>(1.5)</b>	4.60 <b>(15'2")</b>	2.03 <b>(6'8")</b>	2.09 <b>(6'11")</b>	Improved undercarriage
955H	60A	60-66	100	11 320 <b>(24,950)</b>	1.34 <b>(1.75)</b>	4.79 <b>(15'9")</b>	1.90 <b>(6'3")</b>	2.65 <b>(8'8")*</b>	Power shift, Turbo, oil cooled brakes
955K	61H	66-71	115	12 700 <b>(28,000)</b>	1.34 <b>(1.75)</b>	5.00 <b>(16'6")</b>	2.06 <b>(6'9")</b>	2.80 <b>(9'3")*</b>	Horsepower and bucket capacity increase
955L	85J	71-75	130	15 330 <b>(33,800)</b>	1.53 <b>(2.0)</b>	5.30 <b>(16'1")</b>	2.18 <b>(7'2")</b>	2.95 <b>(9'8")*</b>	ROPS Cab, Sealed & Lubricated Track
955L	13X	75-81	130	15 853 <b>(34,950)</b>	1.72 <b>(2.25)</b>	5.26 <b>(17'3")</b>	2.18 <b>(7'2")</b>	2.95 <b>(9'8")</b>	

\*Height to top of stack. Others to top of seat back.

\*\*Overall length to tip of smallest General Purpose bucket.

## Track Loaders (cont'd)

Model	Product Ident. No. Prefix	Years Built	Flywheel Horsepower	Approx. Operating Weight kg (lb)	Rated Capacity m <sup>3</sup> (yd <sup>3</sup> )	Dimensions			Remarks
						Length** m (ft)	Width m (ft)	Height m (ft)	
963	6Z	81-85	150	18 250 <b>(40,250)</b>	2.0 <b>(2.6)</b>	6.35 <b>(20'10")</b>	2.50 <b>(8'2")</b>	3.30 <b>(10'10")</b>	Hydrostatic drive
963	11Z	81-85	150	18 370 <b>(40,490)</b>	2.0 <b>(2.6)</b>	6.35 <b>(20'10")</b>	2.50 <b>(8'2")</b>	3.30 <b>(10'10")</b>	Hydrostatic drive
963	18Z	82-86	150	18 250 <b>(40,250)</b>	2.0 <b>(2.6)</b>	6.35 <b>(20'10")</b>	2.50 <b>(8'2")</b>	3.30 <b>(10'10")</b>	Hydrostatic drive made in France
963	21Z	82-95	150	18 370 <b>(40,490)</b>	2.0 <b>(2.6)</b>	6.35 <b>(20'10")</b>	2.50 <b>(8'2")</b>	3.30 <b>(10'10")</b>	Hydrostatic drive made in France
963B	9BL	95-99	160	19 620 <b>(43,270)</b>	2.45 <b>(3.2)</b>	6.60 <b>(21'8")</b>	2.50 <b>(8'2")</b>	3.31 <b>(10'10")</b>	3116 engine
963C	2DS	99-03	160	19 020 <b>(41,940)</b>	1.75 <b>(2.25)</b>	4.61 <b>(15'2")</b>	2.40 <b>(7'11")</b>	3.32 <b>(10'11")</b>	
963C Tier 2	BBD	03-07	158	19 589 <b>(43,096)</b>	2.45 <b>(3.2)</b>	4.61 <b>(15'2")</b>	2.40 <b>(7'11")</b>	3.39 <b>(11'2")</b>	SystemOne U/C
973	86G	81-00	210	25 040 <b>(55,200)</b>	3.2 <b>(4.2)</b>	7.12 <b>(23'4")</b>	2.85 <b>(9'4")</b>	3.42 <b>(11'3")</b>	
No. 6	10A	53-55	80	13 229 <b>(29,165)</b>	1.5 <b>(2.0)</b>	4.90 <b>(16'1")</b>	2.44 <b>(8'1")</b>	2.11 <b>(6'11")</b>	
977D	20A	55-60	100	14 430 <b>(31,795)</b>	1.72 <b>(2.25)</b>	5.19 <b>(18'0")</b>	2.44 <b>(8'0")</b>	2.22 <b>(7'4")</b>	
977E	20A	58-60	100	15 850 <b>(34,910)</b>	1.72 <b>(2.25)</b>	5.19 <b>(18'0")</b>	2.44 <b>(8'0")</b>	2.29 <b>(7'7")</b>	Improved undercarriage
977H	53A	60-66	150	17 000 <b>(37,500)</b>	1.90 <b>(2.5)</b>	5.28 <b>(17'4")</b>	2.44 <b>(8'0")</b>	2.29 <b>(7'7")</b>	Power shift, Turbo, oil cooled brakes
977K	46H	66-78	170	19 100 <b>(42,000)</b>	1.90 <b>(2.5)</b>	5.50 <b>(18'0")</b>	2.38 <b>(7'10")</b>	3.05 <b>(10'0")*</b>	Walk-through compartment, longer roller frame
977L	14X	78-82	190	21 780 <b>(48,010)</b>	2.10 <b>(2.75)</b>	5.59 <b>(18'4")</b>	2.38 <b>(7'10")</b>	3.32 <b>(10'11")*</b>	Horsepower and bucket capacity increase
983	38K	69-78	275	34 460 <b>(75,980)</b>	3.82 <b>(5.0)</b>	6.78 <b>(22'3")</b>	2.90 <b>(9'6")</b>	2.79 <b>(11'10")*</b>	
983B	58X	78-82	275	35 620 <b>(78,530)</b>	3.82 <b>(5.0)</b>	6.78 <b>(22'3")</b>	2.90 <b>(9'6")</b>	3.68 <b>(12'1")*</b>	DI engine

\*Height to top of stack. Others to top of seat back.

\*\*Overall length to tip of smallest General Purpose bucket.



## INTEGRATED TOOLCARRIERS

Model	Product Ident. No. Prefix	Years Built	Flywheel Horsepower	Approx. Operating Weight kg (lb)	Rated Capacity m <sup>3</sup> (yd <sup>3</sup> )	Breakout Force kg (lb)	Width Over Tires m (ft)	Ground Clearance mm (in)	Max. Reach at Max. Height mm (in)	Dump Clearance at Max. Height m (ft)	Maximum Speeds km/h (mph)	
											Fwd.	Rev.
IT12	2YC	84-89	65	7393 <b>(16,299)</b>	1.0 <b>(1.25)</b>	7193 <b>(15,858)</b>	2.3 <b>(7'8")</b>	405 <b>(15.9")</b>	873 <b>(34")</b>	2.84 <b>(9'4")</b>	23.6 <b>(14.6)</b>	24.9 <b>(15.4)</b>
IT12B	1KF	89-93	78	7950 <b>(17,530)</b>	1.2 <b>(1.6)</b>	6160 <b>(13,583)</b>	2.15 <b>(7'1")</b>	343 <b>(13.5")</b>	958 <b>(37.7")</b>	2.69 <b>(8'10")</b>	34 <b>(21.1)</b>	22.4 <b>(13.9)</b>
IT12F	1KF	93-95	80	7893 <b>(17,401)</b>	1.3 <b>(1.7)</b>	6479 <b>(14,247)</b>	2.15 <b>(7'1")</b>	365 <b>(1'2")</b>	917 <b>(3'1")</b>	2.74 <b>(8'11.8")</b>	34 <b>(21.1)</b>	22.4 <b>(13.9)</b>
IT14B	3NJ	89-93	85	8333 <b>(18,374)</b>	1.2 <b>(1.6)</b>	7525 <b>(16,593)</b>	2.15 <b>(7'1")</b>	344 <b>(13.6")</b>	958 <b>(37.7")</b>	2.70 <b>(8'11")</b>	37.3 <b>(23.2)</b>	24.4 <b>(15.2)</b>
IT14F	4EL	93-95	85	7999 <b>(17,635)</b>	1.3 <b>(1.7)</b>	7170 <b>(15,808)</b>	2.15 <b>(7'1")</b>	365 <b>(1'2")</b>	918 <b>(3'1")</b>	2.74 <b>(9'0")</b>	37.3 <b>(23.2)</b>	24.4 <b>(15.2)</b>
IT18	9NB	84-86	85	8660 <b>(19,092)</b>	1.2 <b>(1.5)</b>	9105 <b>(20,108)</b>	2.4 <b>(7'10")</b>	285 <b>(11.2")</b>	990 <b>(39")</b>	2.84 <b>(9'4")</b>	25 <b>(15.5)</b>	25 <b>(15.5)</b>
IT18B	4ZD	86-92	95	9770 <b>(21,540)</b>	1.3 <b>(1.75)</b>	10 500 <b>(21,350)</b>	2.28 <b>(7'6")</b>	324 <b>(12.8")</b>	993 <b>(39")</b>	2.89 <b>(9'6")</b>	26.4 <b>(16.4)</b>	27.7 <b>(17.2)</b>
IT18F	6ZF	92-94	105	9959 <b>(21,960)</b>	1.6 <b>(2.0)</b>	8880 <b>(19,580)</b>	2.33 <b>(7'8")</b>	321 <b>(1'1")</b>	1089 <b>(3'7")</b>	2.75 <b>(9'0")</b>	37 <b>(23)</b>	24.5 <b>(15.2)</b>
IT24F	4NN	94-99	105	9989 <b>(20,022)</b>	1.7 <b>(2.5)</b>	8782 <b>(19,361)</b>	2.33 <b>(7'6")</b>	321 <b>(12.6")</b>	1088 <b>(3'6")</b>	2.75 <b>(9'0")</b>	38.0 <b>(23.6)</b>	23.4 <b>(14.8)</b>
IT28	2KC	84-86	105	9560 <b>(21,076)</b>	1.5 <b>(2.0)</b>	9505 <b>(20,955)</b>	2.4 <b>(7'10")</b>	285 <b>(11.2")</b>	1044 <b>(41")</b>	2.82 <b>(9'3")</b>	30.8 <b>(18.8)</b>	32.3 <b>(20.0)</b>
IT28B	1HF	86-93	110	10 580 <b>(23,325)</b>	1.7 <b>(2.25)</b>	10 456 <b>(23,050)</b>	2.32 <b>(7'7")</b>	324 <b>(12.8")</b>	1091 <b>(43")</b>	2.73 <b>(8'11")</b>	34.4 <b>(21.4)</b>	37.2 <b>(23.1)</b>
IT28F	3CL	93-96	125	11 430 <b>(25,200)</b>	2.0 <b>(2.6)</b>	9840 <b>(21,700)</b>	2.43 <b>(8'0")</b>	317 <b>(12")</b>	1093 <b>(43")</b>	2.72 <b>(8'11")</b>	35.4 <b>(21.9)</b>	21.4 <b>(13.5)</b>
IT28G	DBT	02-04	146	12 640 <b>(27,860)</b>	2.0 <b>(2.6)</b>	10 631 <b>(23,437)</b>	2.54 <b>(8'4")</b>	407 <b>(16")</b>	958 <b>(38")</b>	2.97 <b>(9'9")</b>	37.7 <b>(23.4)</b>	25.8 <b>(16)</b>
IT28G	EWB	02-05	131	11 250 <b>(24,802)</b>	2.0 <b>(2.6)</b>	11 723 <b>(25,849)</b>	2.44 <b>(8'0")</b>	408 <b>(16")</b>	1455 <b>(4'9")</b>	2.879 <b>(9'5")</b>	37.7 <b>(23.4)</b>	25.8 <b>(16)</b>
IT28G	WAC	02-05	131	11 250 <b>(24,802)</b>	2.0 <b>(2.6)</b>	11 723 <b>(25,849)</b>	2.44 <b>(8'0")</b>	408 <b>(16")</b>	1455 <b>(4'9")</b>	2.879 <b>(9'5")</b>	37.7 <b>(23.4)</b>	25.8 <b>(16)</b>
IT38G Series II	CSX	02-07	160	14 583 <b>(32,156)</b>	2.8 <b>(3.66)</b>	11 216 <b>(24,729)</b>	2.6 <b>(102)</b>	400 <b>(16)</b>	1224 <b>(48)</b>	2733 <b>(108)</b>	38.8 <b>(24.1)</b>	23.3 <b>(14.5)</b>
950F CT	5SK	94-98	170	16 600 <b>(36,580)</b>	3.1 <b>(4.0)</b>	13 590 <b>(29,950)</b>	2.87 <b>(9'5")</b>	460 <b>(18")</b>	1714 <b>(68")</b>	2.845 <b>(9'4")</b>	38.7 <b>(24.0)</b>	42.7 <b>(26.5)</b>



## TELEHANDLERS

Model	Product Ident. No. Prefix	Years Built	Flywheel Horsepower kW (hp)	Operating Weight kg (lb)	Engine	Maximum Lift Height m (ft/in)	Maximum Reach m (ft/in)	Maximum Lift Capacity kg (lb)
TH62	4TM	00-02	72 <b>(105)</b>	6840 <b>(15,080)</b>	3054T	7.6 <b>(25'0")</b>	4.2 <b>(13'9")</b>	2725 <b>(6000)</b>
TH63	5WM	00-02	72 <b>(105)</b>	9260 <b>(20,420)</b>	3054T	12.5 <b>(41'0")</b>	8.1 <b>(26'7")</b>	3000 <b>(6615)</b>
TH82	3JN	00-02	72 <b>(105)</b>	7470 <b>(16,470)</b>	3054T	7.6 <b>(25'0")</b>	4.2 <b>(13'9")</b>	3635 <b>(8000)</b>
TH83	3RN	00-02	72 <b>(105)</b>	10 000 <b>(22,050)</b>	3054T	12.5 <b>(41'0")</b>	8.2 <b>(27'0")</b>	3635 <b>(8000)</b>
TH103	3PN	00-02	72 <b>(105)</b>	12 500 <b>(27,500)</b>	3054T	13.5 <b>(44'0")</b>	8.8 <b>(28'9")</b>	4536 <b>(10,000)</b>
TH210	MHT	03-06	60 <b>(80)</b>	5000 <b>(11,023)</b>	3054B DI	5.18 <b>(17'0")</b>	2.8 <b>(9'2")</b>	2200 <b>(4840)</b>
TH215	MHS	03-06	60 <b>(80)</b>	5500 <b>(12,100)</b>	3054B DI	5.54 <b>(18'2")</b>	3.1 <b>(10'2")</b>	2500 <b>(5500)</b>
TH220B	SLA/TBF	03-07	74.5 <b>(100)</b>	6700 <b>(14,774)</b>	Cat 3054E	6.1 <b>(20'0")</b>	3.3 <b>(10'9")</b>	3500 <b>(7718)</b>
TH330B	SLB/TBG	03-07	74.5 <b>(100)</b>	7200 <b>(15,876)</b>	Cat 3054E	7.2 <b>(23'7")</b>	3.8 <b>(12'6")</b>	3600 <b>(7938)</b>
TH340B	SLC	03-06	74.5 <b>(99.9)</b>	7700 <b>(17,000)</b>	3054E	9.0 <b>(29'6")</b>	6.5 <b>(21'4")</b>	3000 <b>(6600)</b>
TH350B	SLD	03-06	74.5 <b>(99.9)</b>	8480 <b>(18,100)</b>	3054E	11.0 <b>(36'0")</b>	7.4 <b>(24'0")</b>	3000 <b>(6600)</b>
TH360B	SLE/TBH	03-07	74.5 <b>(100)</b>	9970 <b>(21,984)</b>	Cat 3054E	13.5 <b>(44'3")</b>	9.2 <b>(30'2")</b>	3500 <b>(7718)</b>
TH460B	SLF	03-06	74.5 <b>(99.9)</b>	10 500 <b>(21,600)</b>	3054E	13.5 <b>(44'4")</b>	9.2 <b>(30'0")</b>	4000 <b>(8800)</b>
TH560B	SLG/TBP	03-07	74.5 <b>(99.9)</b>	12,000 <b>(26,500)</b>	Cat 3054E	13.5 <b>(44'0")</b>	9.2 <b>(30'0")</b>	5000 <b>(11,000)</b>
TH580B	SLH/TBJ	03-07	74.5 <b>(99.9)</b>	13,670 <b>(30,100)</b>	Cat 3054E	17 <b>(56'0")</b>	12.7 <b>(42'0")</b>	5000 <b>(11,000)</b>



**PAVING PRODUCTS — COLD PLANERS**

Model	Product Ident. No. Prefix	Years Built	kW Flywheel (Horsepower)	Approximate Operating Weight kg (lb)	General Dimensions (Shipping)		
					Height mm (ft)	Length mm (ft)	Width mm (ft)
PR-75		85-92	52 (77)	5900 (13,000)	2690 (8'10")	3050 (10'0")	2130 (7'0")
PR-105		85-92	67 (90)	7711 (17,000)	2921 (9'7")	3581 (11'9")	2515 (8'3")
PR-275	6RC	—	201 (270)	17 237 (38,000)	2896 (9'6")	5740 (18'10")	2438 (8'0")
PR-450		85-92	336 (450)	28 308 (58,000)	4270 (14'0")	13 280 (43'8")	2870 (9'5")
PR-450C		92-97	336 (450)	28 308 (58,000)	3810 (12'6")	13 200 (43'6")	2490 (8'2")
PR-750B		85-92	559 (750)	42 638 (94,000)	3734 (12'3")	16 500 (54'0")	3575 (11'9")
PR-1000			Cutter 559 (750) Track 186 (250)	46 780 (103,130)	3810 (12'6")	16 590 (54'5")	4877 (16'0")
PM-465	5ZS	97-03	353 (473)	14 333 (31,600)	2820 (9'3")	13 716 (45'0")	2489 (8'2")
PM-565		xx-05	466 (625)	38 595 (85,100)	5040 (16'6")	15 100 (49'5")	2790 (9'2")



**PAVING PRODUCTS — RECLAIMERS & STABILIZERS**

Model	Product Ident. No. Prefix	Years Built	kW Flywheel (Horsepower)	Approximate Operating Weight kg (lb)	General Dimensions (Shipping)		
					Height mm (ft)	Length mm (ft)	Width mm (ft)
SS-250	6DD	85-96	250 (335)	13 300 (29,300)	3220 (10'7")	8780 (28'10")	2900 (9'7")
SS-250B	5GR	96-01	250 (335)	14 340 (31,600)	2600 (8'6")	8560 (28'1")	2900 (9'6")
RR-250	6ED	85-96	250 (335)	17 876 (39,300)	3220 (10'7")	8780 (28'10")	2900 (9'7")
RR-250B	3RR	96-01	250 (335)	19 260 (42,470)	2600 (8'6")	8560 (28'1")	2900 (9'6")
RM-250C			250 (335)	16 780 (37,000)	3220 (10'7")	8780 (28'10")	2921 (9'7")
RM-350	5FK	92-97	321 (430)	21 440 (47,200)	3404 (11'2")	9577 (31'5")	2997 (9'10")
SM-350	1RM	92-97	321 (430)	18 440 (40,600)	3404 (11'2")	9577 (31'5")	2997 (9'10")
RM-350B			373 (500)	24 040 (53,000)	3404 (11'2")	9980 (32'9")	2997 (9'10")



**PAVING PRODUCTS — UNITIZED VENTURI-MIXERS & UNITIZED DRUM-MIXERS**

Drum Dimensions			Performance		
Model	Diameter mm (ft)	Length m (ft)	Gross Volume m <sup>3</sup> (ft <sup>3</sup> )	Production Range/hr. metric tons (tons)	Air Flow m <sup>3</sup> /min (ft <sup>3</sup> /min)
UVM-500	1829/1524 (6'0"/5'0")	7.9 (26'0")	14.17 (500)	68-109 (75-120)	300-481 (10,600-17,000)
UDM-600	1829 (6'0")	6.7 (22'0")	17.00 (600)	82 (89)	354.25 (12,500)
UDM-900	2134/1829 (7'0"/6'0")	9.1 (30'0")	25.48 (900)	68-227 (75-250)	311-793 (11,000-28,000)
UVM-1000	2134 (7'0")	9.754 (32'0")	28.34 (1000)	82-272 (90-300)	425-1076 (15,000-38,000)
UVM-1400	2286 (7'6")	10.973 (36'0")	39.64 (1400)	100-358 (110-395)	481-1274 (17,000-45,000)
UVM-1700	2591 (8'6")	11.582 (38'0")	48.14 (1700)	122-480 (135-450)	651-1614 (23,000-57,000)



**PAVING PRODUCTS — PORTABLE VENTURI-MIXERS**

Drum Dimensions			Performance		
Model	Diameter mm (ft)	Length m (ft)	Gross Volume m <sup>3</sup> (ft <sup>3</sup> )	Production Range/hr. metric tons (tons)	Air Flow m <sup>3</sup> /min (ft <sup>3</sup> /min)
PVM-1100	2134 (7'0")	10.97 (36'0")	31.15 (1100)	82-295 (90-325)	425-1133 (15,000-40,000)
PVM-1500	2286 (7'6")	12.19 (40'0")	42.48 (1500)	100-363 (110-400)	510-1274 (18,000-45,000)
PVM-2000	2591 (8'6")	12.80 (42'0")	56.64 (2000)	122-454 (135-500)	680-1699 (24,000-60,000)
PVM-2500	2896 (9'6")	12.80 (42'0")	70.79 (2500)	136-499 (150-550)	793-2110 (28,000-74,500)
PVM-2900	3048 (10'0")	13.41 (44'0")	82.12 (2900)	168-553 (185-610)	906-2265 (32,000-80,000)
PVM-3300	3200 (10'6")	13.41 (44'0")	93.45 (3300)	181-612 (200-675)	991-2464 (35,000-87,000)

**PAVING PRODUCTS — STATIONARY VENTURI-MIXERS**

Drum Dimensions			Performance		
Model	Diameter mm (ft)	Length m (ft)	Gross Volume m <sup>3</sup> (ft <sup>3</sup> )	Production Range/hr. metric tons (tons)	Air Flow m <sup>3</sup> /min (ft <sup>3</sup> /min)
SVM-1100	2134 (7'0")	10.97 (36'0")	31.15 (1100)	82-295 (90-325)	425-1133 (15,000-40,000)
SVM-1500	2286 (7'6")	12.19 (40'0")	42.48 (1500)	100-363 (110-400)	510-1274 (18,000-45,000)
SVM-2000	2591 (8'6")	12.80 (42'0")	56.64 (2000)	122-454 (135-500)	680-1699 (24,000-60,000)
SVM-2500	2896 (9'6")	12.80 (42'0")	70.79 (2500)	136-499 (150-550)	793-2110 (28,000-74,500)
SVM-2900	3048 (10'0")	13.41 (44'0")	82.12 (2900)	168-553 (185-610)	906-2265 (32,000-80,000)
SVM-3600	3200 (10'6")	14.63 (48'0")	101.94 (3600)	190-623 (210-685)	1020-2565 (36,000-90,000)

**PAVING PRODUCTS — SLIPFORM PAVERS**

Model	Product Ident. No. Prefix	Years Built	Flywheel Horsepower	Approx. Operating Weight kg (lb)	Standard Paving Width m (ft)	Shipping Dimensions (Min.)			Remarks
						Length m (ft)	Width m (ft)	Height m (ft)	
SF-175	5ZC	—	142	9072 (20,000)	2.1 (7'0")	6.6 (21'6")	2.4 (8'0")	2.8 (9'4")	
SF-250	6XC	—	208	24 494 (54,000)	3.6 (12'0")	3.0 (10'0")	3.7 (12'0")		
SF-250B	—	—	250	27 216 (60,000)	3.7-7.3 (12'0"-24'0")	1.5 (5'0")	3.66 (12'0")	3.20 (10'6")	
SF-350	—	—	290	40 824 (90,000)	3.6-7.3 (12'0"-24'0")	1.04 (3'5")	3.0 (10'0")	2.9 (9'8")	
SF-450	7GC	73-83	400	43 546* (96,000) 53 525** (118,000)	3.66-7.62 (12'0"-25'0")	9.35 (30'8")	3.05 (10'0")	2.90 (9'6")	
SF-500	8DC	—	400	52 164 (115,000)	7.6 (25'0")	8.9 (29'2½")	3.0 (10'0")	3.0*** (10'2")	
SF-550	5PD	—	400	52 164 (115,000)	5.5-8.5 (18'0"-28'0")	7.0 (23'0")	3.7 (12'0")	2.9 (9'8")	

\*Weight of 7.62 m (25'0") machine.

\*\*Weight of 11.58 m (38'0") machine.

\*\*\*Machine legs and track shipped separately.



## Former Models

### Paving Products

- Placer-Spreader-Trimmer ● Belt Placer
- Tube Finisher ● Texturing/Curing
- Trimmer-Reclaimer



### PAVING PRODUCTS — PLACER-SPREADER-TRIMMER, BELT PLACER

Model	Product Ident. No. Prefix	Years Built	Flywheel Horsepower	Approximate Operating Weight kg (lb)	General Dimensions		
					Height m (ft)	Length m (ft)	Width m (ft)
PST-300	8EC	—	250	38 193 (84,200)	2.64 (8'8")	10.57 (34'8")	9.02 (29'7")
BP-100	1EF	—	102	11 340 (22,000)	3.27 (10'9")	2.49 (8'2")	2.49 (8'2")



### PAVING PRODUCTS — TUBE FINISHER, TEXTURING/CURING

Model	Product Ident. No. Prefix	Years Built	Flywheel Horsepower	Approximate Operating Weight kg (lb)	General Dimensions (Shipping)		
					Height mm (ft)	Length mm (ft)	Width mm (ft)
TF-250	6YC	—	52	5897 (13,000)	2489 (8'2")	8484 (27'10")	2438 (8'0")
TC-250	7HC	—	56	5897 (13,000)	2489 (8'2")	8484 (27'10")	2438 (8'0")

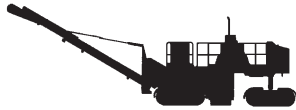

### PAVING PRODUCTS — TRIMMER-RECLAIMER

Model	Product Ident. No. Prefix	Years Built	Flywheel Horsepower	Approximate Operating Weight kg (lb)	General Dimensions (Shipping)		
					Height mm (ft)	Length m (ft)	Width mm (ft)
TR-225B	6WC	—	250	21 319 (47,000)	3200 (10'6")	13.9 (45'9.5")	2896 (9'6")
TR-500	8CC	—	375	46 267 (102,000)	3099 (10'2")	8.9 (29'2¾")	3048 (10'0")



**PAVING PRODUCTS — ASPHALT PAVERS & WINDROW ELEVATORS**

Model	Product Ident. No. Prefix	Years Built	Flywheel kW (hp)	Approx. Op. Weight kg (lb)	Drive	Screed Width mm (ft)	Hopper Capacity m <sup>3</sup> (ft <sup>3</sup> )	Maximum Op. Speed m/min (ft/min)
AP-200	2NK	86-01	26 (35)	4080 (9000)	Track	2743 (9'0")	5.4 t (6 T)	53.6 (176)
AP-200	6AD	85-91	26 (35)	4080 (9000)	Track	2743 (9'0")	5.4 t (6 T)	0-54 (0-177)
AP-650B		-08	97 (130)	13 917 (30,655)		2400 (8'0")	5 t (177 T)	67 (220)
AP-800	1BF	86-89	76 (102)	11 903 (26,350)	Wheel	2438 (8'0")	5.8 (206)	95 (312)
AB-800B	1BF	89-93	76 (102)	11 903 (26,350)	Wheel	2438 (8'0")	5.8 (206)	95 (312)
AP-800C			80 (107)	12 115 (26,700)	Wheel	2438 (8'0")	5.5 (195)	76 (250)
AP-800D			80 (107)	12 115 (26,700)	Wheel	2400 (8'0")	5.5 (195)	76 (250)
AP-900		-06	114 (153)	14 445 (31,850)	Wheel	3000 (10'0")	6.1 (215)	122 (400)
AP-1000B		-05	130 (174)	15 490 (34,150)	Wheel	3000 (10'0")	6.1 (215)	114 (374)
AP-1050	1JG	89-96	116 (155)	14 878 (32,800)	Track	3048 (10'0")	6.2 (215)	57 (186)
AP-1050B			130 (174)	16 015 (35,300)	Track	3048 (10'0")	6.1 (215)	61 (200)
AP-1055B			130 (174)	16 556 (36,500)	Track	3048 (10'0")	6.1 (215)	61 (200)
AP-1200	2JD	85-89	108 (145)	13 608 (30,000)	Wheel	3048 (10'0")	6.2 (220)	21.4 (13.3)
WE601B	TEC	85-91	78 (102)	3856 (8500)	N/A	1524 (5'0")	N/A	N/A
BG-200A	N/A	89-91	35 (47)	6750 (14,900)	Wheel	1803 (5'11")	3.26 (116)	56 (180)
BG-210	N/A	90-91	79 (106)	10 192 (22,500)	Wheel	2438 (8'0")	4.76 (170)	84 (275)
BG-210B	N/A	91-01	80 (107)	11 793 (26,000)	Wheel	2438 (8'0")	4.8 (170)	0-21.7 (0-13.5)
BG-220	N/A	84-87	58 (78)	9752 (21,500)	Wheel	2438 (8'0")	3.7 (130)	88 (289)
BG-220B	4ZM	91-94	80 (108)	12 483 (27,525)	Wheel	2438 (8'0")	4.3 (155)	88 (289)
BG-225	N/A	84-87	58 (78)	11 339 (25,000)	Track	2438 (8'0")	3.7 (130)	58 (188)
BG-225B	N/A		118 (158)	16 400 (36,200)	Track	2438 (8'0")	4.3 (155)	57 (189)
BG-225C			97 (130)	13 917 (30,655)	Track	2400 (8'0")	5 (177)	67 (220)

## Former Models

- Paving Products
- Asphalt Pavers
  - Windrow Elevators

### Paving Products — Asphalt Pavers & Windrow Elevators (cont'd)

Model	Product Ident. No. Prefix	Years Built	Flywheel kW (hp)	Approx. Op. Weight kg (lb)	Drive	Screed Width mm (ft)	Hopper Capacity m <sup>3</sup> (ft <sup>3</sup> )	Maximum Op. Speed m/min (ft/min)
BG-230			80 (107)	12 111 (26,700)	Wheel	2438 (8'0")	5.5 (195)	76 (250)
BG-230D			97 (130)	13 307 (29,310)	Wheel	2400 (8'0")	5.5 (195)	76 (250)
BG-240	N/A	85-86	72 (96)	13 154 (29,000)	Wheel	3048 (10'0")	3.7 (130)	81 (265)
BG-240B	7RL	87-99	86 (115)	15 200 (33,500)	Wheel	3048 (10'0")	6.5 (230)	81 (265)
BG-245	N/A	85-87	72 (96)	14 514 (32,000)	Track	3048 (10'0")	5.8 (206)	58 (189)
BG-245B	3XL	87-96	116 (155)	16 080 (35,450)	Track	3048 (10'0")	5.8 (206)	55 (182)
BG-245C	N/A		130 (174)	16 015 (35,300)	Track	3048 (10'0")	6.1 (215)	60.1 (200)
BG-2455C	N/A		130 (174)	16 555 (36,500)	Track	3048 (10'0")	6.1 (215)	61 (200)
BG-260	N/A	85-87	106 (142)	14 514 (32,000)	Wheel	3048 (10'0")	5.8 (206)	77 (253)
BG-260B	N/A		116 (155)	14 740 (32,500)	Wheel	3048 (10'0")	5.8 (206)	90 (296)
BG-265	N/A	85-87	106 (142)	16 782 (37,000)	Track	3048 (10'0")	5.8 (206)	50 (164)
BG-265B	7XK	87-98	145 (195)	18 380 (40,570)	Track	3048 (10'0")	5.8 (206)	50 (164)
BG-270B	N/A		145 (195)	15 510 (34,200)	Wheel	3048 (10'0")	6.5 (230)	90 (296)
BG-610	N/A	85	58 (78)	4394 (9700)	N/A	1524 (5'0")	N/A	N/A
BG-610A	N/A	86-90	58 (78)	4911 (10,840)	N/A	1524 (5'0")	N/A	N/A
BG-650	N/A		80 (107)	7984 (17 600)	N/A	N/A	N/A	N/A
BG-710	N/A		111 (149)	13 380 (29,500)	Wheel	3048 (10'0")	10.0 (80)	98 (320)
BG-730	N/A	87-02	114 (153)	14 061 (31,000)	Wheel	3048 (10'0")	10.0 (80)	0-24.1 (0-15.0)
BG-750	N/A	87-97	116 (155)	17 010 (37,500)	Wheel	4270 (14'0")	10.0 (80)	0-24.1 (0-15.0)
MTP-1260	N/A	86-90	58 (78)	4911 (10,840)	N/A	3048 (10'0")	7.7 (275)	58 (189)
MTP-1265	N/A	88-91	167 (224)	25 368 (56,000)	N/A	3048 (10'0")	11.2 (400)	50 (164)



PAVING PRODUCTS — SINGLE DRUM VIBRATORY COMPACTORS

Model	Product Ident. No. Prefix	Years Built	Flywheel kW (hp)	Approx. Op. Weight kg (lb)	Drive	Drum Width mm (in)	Centrifugal Force kg (lb)	Maximum Op. Speed km/h (mph)
CS-323	1TM	85-95	57 <b>(77)</b>	4173 <b>(9200)</b>	Wheel/ Drum	1219 <b>(48")</b>	5760 <b>(12,700)</b>	0-10.9 <b>(0-6.8)</b>
CP-323	6JD	85-95	57 <b>(77)</b>	4218 <b>(9300)</b>	Wheel/ Drum	1219 <b>(48")</b>	5760 <b>(12,700)</b>	0-10.9 <b>(0-6.8)</b>
CS-431	6MD	85-87	52 <b>(70)</b>	6110 <b>(13,480)</b>	Wheel	1680 <b>(66")</b>	7260 <b>(16,000)</b>	21 <b>(13)</b>
CS-431B	1XF	88-94	76.5 <b>(102)</b>	6312 <b>(13,915)</b>	Wheel	1680 <b>(66")</b>	11 235 <b>(24,746)</b>	12.8 <b>(8.0)</b>
CS-431C	9XL	94-01	78 <b>(105)</b>	6509 <b>(14,349)</b>	Wheel/ Drum	1680 <b>(66")</b>	13 609 <b>(30,000)</b>	12.8 <b>(8.0)</b>
CS-433	6ND	85-87	60 <b>(80)</b>	6720 <b>(14,820)</b>	Wheel/ Drum	1524 <b>(60")</b>	7260 <b>(16,000)</b>	10 <b>(6)</b>
CP-433	6NP	85-87	60 <b>(80)</b>	6750 <b>(14,870)</b>	Wheel/ Drum	1524 <b>(60")</b>	7260 <b>(16,000)</b>	10 <b>(6)</b>
CS-433B	4FK	88-94	76.5 <b>(102)</b>	6448 <b>(14,215)</b>	Wheel/ Drum	1680 <b>(66")</b>	11 235 <b>(24,746)</b>	12.8 <b>(8.0)</b>
CS-433C	3TM	94-01	78 <b>(105)</b>	6773 <b>14,931</b>	Wheel/ Drum	1680 <b>(66")</b>	13 609 <b>(30,000)</b>	12.8 <b>(8.0)</b>
CP-433B	1MG	88-94	76.5 <b>(102)</b>	6668 <b>(15,225)</b>	Wheel/ Drum	1680 <b>(66")</b>	11 235 <b>(24,746)</b>	12.8 <b>(8.0)</b>
CP-433C	2JM	94-01	78 <b>(105)</b>	7075 <b>(15,597)</b>	Wheel/ Drum	1680 <b>(66")</b>	13 609 <b>(30,000)</b>	12.8 <b>(8.0)</b>
CS-531	3WM	93-95	108 <b>(145)</b>	9310 <b>(20,500)</b>	Wheel	2134 <b>(84")</b>	22 680 <b>(50,000)</b>	12.8 <b>(8.0)</b>
CS-531C	5ZN	95-00	108 <b>(145)</b>	9300 <b>(20,450)</b>	Wheel	2134 <b>(84")</b>	24 091 <b>(53,000)</b>	12.8 <b>(8.0)</b>
CS-531D	3AZ 4MZ AGH	98-99 99-04 01-03	108 <b>(145)</b>	9650 <b>(21,230)</b>	Rear Wheel	2130 <b>(84")</b>	27 124 <b>(60,000)</b>	12.7 <b>(7.8)</b>
CS-533	3BL	93-95	108 <b>(145)</b>	10 110 <b>(22,500)</b>	Wheel/ Drum	2134 <b>(84")</b>	22 680 <b>(50,000)</b>	12.8 <b>(8.0)</b>
CS-533C	2WN	95-00	108 <b>(145)</b>	9500 <b>(20,900)</b>	Wheel/ Drum	2134 <b>(84")</b>	24 091 <b>(53,000)</b>	12.8 <b>(8.0)</b>
CS-533D	AET 5CZ	00-03 00-04	108 <b>(145)</b>	9960 <b>(21,912)</b>	Drum/ Rear Wheel	2130 <b>(84")</b>	27 124 <b>(60,000)</b>	12.7 <b>(7.8)</b>
CP-533	3ZL	93-95	108 <b>(145)</b>	11 470 <b>(25,250)</b>	Wheel/ Drum	2134 <b>(84")</b>	22 680 <b>(50,000)</b>	12.8 <b>(8.0)</b>
CP-533C	3XN	95-00	108 <b>(145)</b>	10 180 <b>(22,400)</b>	Wheel/ Drum	2134 <b>(84")</b>	24 091 <b>(53,000)</b>	12.8 <b>(8.0)</b>
CP-533D	6AZ AFC	01-04 00-03	108 <b>(145)</b>	10 240 <b>(22,528)</b>	Drum/ Rear Wheel	2130 <b>(84")</b>	27 124 <b>(60,000)</b>	13.2 <b>(8.1)</b>

## Paving Products — Single Drum Vibratory Compactors (cont'd)

Model	Product Ident. No. Prefix	Years Built	Flywheel kW (hp)	Approx. Op. Weight kg (lb)	Drive	Drum Width mm (in)	Centrifugal Force kg (lb)	Maximum Op. Speed km/h (mph)
CS-551	6ZD 8AD	85-89	115 (155)	10 428 (22,990)	Wheel	2130 (84")	18 150 (40,000)	12.1 (7.5)
CS-553	7AD	85-89	115 (155)	10 782 (23,770)	Wheel/ Drum	2130 (84")	18 150 (40,000)	10.5 (6.5)
CP-553	7BD	85-89	115 (155)	12 247 (27,000)	Wheel/ Drum	2130 (84")	22 680 (50,000)	10.5 (6.5)
CS-563	8XF	89-95	108 (145)	11 130 (24,500)	Wheel/ Drum	2134 (84")	22 680 (50,000)	12.8 (8.0)
CS-563C	4KN	95-00	108 (145)	11 215 (24,700)	Wheel/ Drum	2134 (84")	24 091 (53,000)	12.8 (8.0)
CS-563D	9MW	98-02	108 (145)	10 875 (23,975)	Wheel/ Drum	2130 (84")	27 216 (60,000)	12.7 (7.8)
CP-563	1YJ	89-95	108 (145)	11 580 (25,800)	Wheel/ Drum	2134 (84")	22 680 (50,000)	12.8 (8.0)
CP-563C	5JN	95-00	108 (145)	11 670 (25,700)	Wheel/ Drum	2134 (84")	24 091 (53,000)	12.8 (8.0)
CP-563D	9ZW	98-02	108 (145)	11 275 (24,856)	Wheel/ Drum	2130 (84")	27 216 (60,000)	13.2 (8.1)
CS-573C	6LN	95-00	108 (145)	13 800 (30,360)	Wheel/ Drum	2134 (84")	24 091 (53,000)	12.8 (8.0)
CS-573D	CMK	00-02	108 (145)	12 180 (29,060)	Wheel/ Drum	2130 (84")	27 216 (60,000)	12.7 (7.8)
CS-583	8YJ	91-95	108 (145)	15 040 (33,090)	Wheel/ Drum	2134 (84")	22 680 (50,000)	12.8 (8.0)
CS-583C	7MN	95-00	108 (145)	15 230 (33,500)	Wheel/ Drum	2134 (84")	24 091 (53,000)	12.8 (8.0)
CS-583D	2CZ	98-02	108 (145)	14 850 (32,740)	Wheel/ Drum	2130 (84")	31 751 (70,000)	12.7 (7.8)
CS-643	7FD	85-87	100 (134)	14 900 (32,855)	Wheel/ Drum	2200 (86")	16 800 (37,044)	15.5 (9.6)
CP-643	7GD	85-87	100 (134)	16 300 (35,942)	Wheel/ Drum	2200 (86")	12 600 (27,783)	15.5 (9.6)
CS-653	7HD	85-91	100 (134)	17 100 (37,690)	Wheel/ Drum	2200 (86")	22 230 (48,995)	15.5 (9.6)
CP-653	7JD	85-91	100 (134)	18 500 (40,774)	Wheel/ Drum	2200 (86")	22 230 (48,995)	15.5 (9.6)
TSF-54	7KD	85-88	26 (35)	2131 (4700)	Towed	1370 (54")	6810 (15,000)	Towed
TSM-54	7LD	86-88	26 (35)	2160 (4760)	Towed	1370 (54")	6810 (15,000)	Towed



**PAVING PRODUCTS — DOUBLE DRUM, COMBI AND PNEUMATIC TIRE COMPACTORS**

Model	Product Ident. No. Prefix	Years Built	Flywheel kW (hp)	Approx. Op. Weight kg (lb)	Drive	Drum Width mm (in)	Centrifugal Force kg (lb)	Maximum Op. Speed km/h (mph)
CB-214	6FD	85-88	24 <b>(33)</b>	2300 <b>(5070)</b>	Drum (2)	1000 <b>(39.4")</b>	2041 <b>(4500)</b>	10.6 <b>(6.6)</b>
CB-214B	6LF	88-93	24 <b>(33)</b>	2300 <b>(5072)</b>	Drum (2)	990 <b>(39")</b>	2018 <b>(4450)</b>	10.4 <b>(6.5)</b>
CB-214C	6LF	93-00	25 <b>(33)</b>	2320 <b>(5115)</b>	Drum (2)	1000 <b>(39.4")</b>	2592 <b>(5715)</b>	10.5 <b>(6.5)</b>
CB-214D	1TZ	99-03	23.5 <b>(31.5)</b>	2430 <b>(5355)</b>	Hydraulic	1000 <b>(39.4")</b>	2590 <b>(5710)</b>	10 <b>(6.2)</b>
CB-214E		-08	24.4 <b>(32.7)</b>	2450 <b>(5400)</b>	Hydraulic	1000 <b>(3'3")</b>	27.6 <b>(6075)</b>	10 <b>(6)</b>
CB-224	6GD	85-88	24 <b>(33)</b>	2450 <b>(5400)</b>	Drum (2)	1200 <b>(47.2")</b>	2450 <b>(5400)</b>	10.6 <b>(6.6)</b>
CB-224B	6LF	88-93	24 <b>(33)</b>	2450 <b>(5402)</b>	Drum (2)	1199 <b>(47.2")</b>	2449 <b>(5400)</b>	10.4 <b>(6.5)</b>
CB-224C	6LF	93-00	25 <b>(33)</b>	2420 <b>(5335)</b>	Drum (2)	1200 <b>(47.2")</b>	2920 <b>(6570)</b>	10.5 <b>(6.5)</b>
CB-224D	8RZ	99-03	23.5 <b>(31.5)</b>	2610 <b>(5750)</b>	Hydraulic	1200 <b>(47.2")</b>	3039 <b>(6700)</b>	10 <b>(6.2)</b>
CB-224E		-08	24.4 <b>(32.7)</b>	2630 <b>(5800)</b>	Hydraulic	1200 <b>(3'11")</b>	31.4 <b>(6975)</b>	10 <b>(6)</b>
CB-225D	9FZ	99-03	23.5 <b>(31.5)</b>	2390 <b>(5270)</b>	Hydraulic	1200 <b>(47.2")</b>	3039 <b>(6700)</b>	10 <b>(6.2)</b>
CB-225E		-08	24.4 <b>(32.7)</b>	2300 <b>(5070)</b>	Hydraulic	1200 <b>(3'11")</b>	31.4 <b>(6975)</b>	10 <b>(6)</b>
CB-314	6HD	85-89	41 <b>(55)</b>	3357 <b>(7400)</b>	Drum	1120 <b>(44")</b>	2770 <b>(6100)</b>	8 <b>(5)</b>
CB-334D	3JZ 4CZ DCZ	98-03 98-02 02-04	32 <b>(43)</b>	3850 <b>(8490)</b>	Hydraulic	1300 <b>(51")</b>	3263 <b>(7250)</b>	11 <b>(7)</b>
CB-334E		-08	34.1 <b>(46)</b>	3940 <b>(8688)</b>	Hydraulic	1300 <b>(4'3")</b>	33.1 <b>(7448)</b>	12.5 <b>(8)</b>
CB-335D	5PZ BBW D4E	98-03 00-03 02-03	32 <b>(43)</b>	3620 <b>(7980)</b>	Hydraulic	1300 <b>(51")</b>	3263 <b>(7250)</b>	11 <b>(7)</b>
CB-335E		-08	34.1 <b>(46)</b>	3670 <b>(8092)</b>	Hydraulic	1300 <b>(4'3")</b>	33.1 <b>(7448)</b>	12.5 <b>(8)</b>
CB-414	6KD	85-89	52 <b>(70)</b>	5780 <b>(12,750)</b>	Drum	1397 <b>(55")</b>	6350 <b>(14,000)</b>	13.7 <b>(8.5)</b>
CB-424	6LD	85-89	54 <b>(73.5)</b>	6220 <b>(13,710)</b>	Drum (2)	1397 <b>(55")</b>	4485 <b>(9885)</b>	11.0 <b>(6.8)</b>
CB-434	3TF	89-94	60 <b>(80)</b>	6610 <b>(14,540)</b>	Drum (2)	1422 <b>(56")</b>	7620 <b>(16,800)</b>	11.6 <b>(7.2)</b>
CB-434B	6AL	94-95	60 <b>(80)</b>	6577 <b>(14,500)</b>	Drums	1422 <b>(56")</b>	7620 <b>(16,800)</b>	0-11.6 <b>(0-7.2)</b>
CB-434C	4DN	95-03	52 <b>(70)</b>	6485 <b>(14,300)</b>	Hydraulic	1422 <b>(56")</b>	7620 <b>(16,800)</b>	11.6 <b>(7.2)</b>
CB-514	6YD	85-88	68 <b>(91)</b>	9730 <b>(21,450)</b>	Drum (2)	1730 <b>(68")</b>	9073 <b>(20,000)</b>	11 <b>(7)</b>
CB-521	6RD	85-87	61 <b>(82)</b>	8800 <b>(19,404)</b>	Wheel	1700 <b>(67")</b>	5300 <b>(11,687)</b>	15 <b>(9.3)</b>

**Paving Products — Double Drum, Combi and Pneumatic Tire Compactors (cont'd)**

Model	Product Ident. No. Prefix	Years Built	Flywheel kW (hp)	Approx. Op. Weight kg (lb)	Drive	Drum Width mm (in)	Centrifugal Force kg (lb)	Maximum Op. Speed km/h (mph)
CB-522	6SD	85-87	45 (62)	10 100 (22,271)	Drum (2)	1700 (67")	10 350 (22,822)	8 (5)
CB-523	6TD	85-87	61 (82)	8800 (19,404)	Wheel/ Drum	1700 (67")	5300 (11,687)	13 (8)
CB-524	6WD	85-87	61 (82)	9500 (20,948)	Drum (2)	1700 (67")	10 350 (22,822)	11 (6.8)
CB-534	6EG2YF	87-93	93 (125)	9117 (20,100)	Drum (2)	1700 (67")	11 800 (26,019)	11.2 (7)
CB-534B	4JL	93-95	80 (107)	9117 (20,100)	Drums	1676 (66")	12 043 (26,550)	0-11.3 (0-7.0)
CB-534C	5HN	95-02	75 (100)	9195 (20,270)	Drums	1700 (67")	11 975 (26,400)	11.3 (7.0)
CB-534D			97 (130)	10 380 (22,836)	Drums	1700 (67")	11 434 (25,208)	13 (8)
CB-534D XW			97 (130)	11 300 (24,860)	Drums	2000 (79")	11 434 (25,208)	13 (8)
CB-544	8FM	94-01	60 (80)	10 700 (23,593)	Drums	1700 (67")	8850 (19,510)	8.9 (5.5)
CB-545	2FS	96-01	60 (80)	9410 (20,750)	Wheel/ Drum	1700 (67")	8850 (19,510)	8.9 (5.5)
CB-564D			97 (130)	12 600 (27,783)	Drums	2130 (84")	10 085 (22,234)	13 (8)
CB-614	7CD	85-93	115 (155)	11 340 (25,000)	Drum (2)	1980 (78")	9525 (21,000)	11.2 (7)
CB-634	5CL	94-95	108 (145)		Drums	2134 (84")	12 043 (26,550)	0-9.2 (0-5.7)
CB-634C	3BR	95-01	108 (145)	11 680 (25,750)	Drums	2134 (84")	12 043 (26,550)	12.2 (7.6)
PF-200		85-92	49 (66)	7000 (15,430)	Wheel Pneumatic	1700 (67")	N/A	24 (14.9)
PS-110	7MD	85-96	57 (77)	12 500 (27,550)	Wheel Pneumatic	2134 (84")	N/A	38.6 (24)
PS-130	7ND	85-96	57 (77)	12 500 (27,550)	Wheel Pneumatic	1700 (67")	N/A	38.6 (24)
PS-150	7PD	85-96	57 (77)	15 050 (37,300)	Wheel Pneumatic	1700 (67")	N/A	38.6 (24)
PS-150B	3XR	95-04	52 (70)	12 940 (28,535)	Hydraulic	1743 (69")	N/A	25.6 (15.9)
PS-180	7PD	85-96	57 (77)	16 950 (37,000)	Wheel Pneumatic	1727 (68")	N/A	38.6 (24)
PS-200B	5JR	95-04	78 (105)	13 010 (28,685)	Hydraulic	1743 (69")	N/A	19.3 (12)
PS-300	7TD	85-95	77 (102)	21 000 (46,200)	Wheel Pneumatic	1900 (75")	N/A	26.5 (16.4)
PS-300B	7WD	85-95	74 (105)	14 000 (30,860)	Wheel Pneumatic	1920 (77")	N/A	19 (11.8)
PF-300B			75 (100)	21 000 (46,200)	Wheel Pneumatic	1900 (75")		13 (8)
PS-360B			78 (105)	8500 (18,740)	Wheel Pneumatic	2275 (90")	N/A	18 (11)



## UNDERGROUND MINING

LHD Model	Product Ident. No. Prefix (USA)	Years Built	Flywheel Power kW (hp)	Approx. Operating Weight kg (lb)	Max. Capacity kg (lb)	Length m (ft)	Height m (ft)	Bucket Width mm (ft)	Breakout Force kg (lb)	Maximum Speeds km/h (mph)	
										Forward	Reverse
R1300	6QW	96-03	123 (165)	20 150 (44,430)	6500 (14,330)	8.66 (28'5")	2.00 (6'7")	2000 (6'7")	12 020 (26,500)	26.1 (16.2)	23.8 (14.6)
R1300GII	RSL	04-08	136 (182)	20 875 (46,021)	6800 (14,991)	8.71 (28'7")	2.12 (6'11")	2200 (7'3")	15 350 (33,841)	26.1 (16.2)	25.9 (16.1)
R1500	BAY	86-00	178 (239)	25 100 (55,360)	9000 (19,850)	9.19 (30'2")	2.30 (7'7")	2480 (8'2")	18 460 (40,700)	30.4 (18.9)	33.0 (20.5)
R1600	9XP	01-03	201 (270)	29 800 (65,710)	10 200 (22,490)	9.71 (31'10")	2.40 (7'10")	2600 (8'6")	19 280 (42,510)	30.6 (19.0)	34.0 (21.1)
R1600G	9PP	03-08	201 (270)	29 800 (65,698)	10 200 (22,487)	9.71 (31'10")	2.40 (7'10")	2600 (8'6")	19 000 (41,888)	22.9 (14.2)	23.81 (14.8)
R1700 Series II	4LZ	94-00	231 (310)	34 500 (76,100)	12 000 (26,460)	10.42 (34'2")	2.53 (8'4")	2820 (9'3")	23 430 (51,660)	29.3 (18.2)	33.3 (20.7)
R1700G	8XZ	99-06	262/241 (351/323)	38 500 (84,878)	14 000* (30,865)	10.59 (34'9")	2.56 (8'5")	2894 (9'6")	20 100 (44,313)	24.13 (15.0)	25.28 (15.7)
R2800	BBR	88-98	231 (310)	42 660 (94,070)	16 200 (35,720)	10.70 (35'1")	2.68 (8'10")	3000 (9'10")	26 540 (68,530)	29.3 (18.2)	33.3 (20.7)
R2900	5TW	95-03	269 (361)	48 850 (107,710)	17 200 (37,930)	10.97 (36'0")	2.888 (9'6")	3100 (10'2")	28 600 (63,060)	26.7 (16.6)	32.5 (20.2)
R2900G	GLK	02-05	306 (410)	50 100 (110,451)	17 200 (39,930)	11.302 (37'1")	2.886 (9'6")	3176 (10'5")	27 346 (60,298)	25.3 (15.7)	26.4 (16.4)
R2900G XTRA	GLK	02-05	306 (410)	53 100 (117,065)	20 000 (44,092)	11.302 (37'1")	2.886 (9'6")	3400 (11'2")	27 346 (60,298)	25.3 (15.7)	26.4 (16.4)

\*14 000 kg (30,865 lb) tramping only, 12 500 kg (27,558 lb) truck loading.



## Former Models

## Underground Mining

- Articulated Trucks
- Rigid Frame Trucks



## UNDERGROUND MINING

### Articulated Trucks

UADT Model	Product Ident. No. Prefix (USA)	Years Built	Flywheel Power kW (hp)	Approx. Operating Weight kg (lb)	Max. Capacity kg (lb)	Length m (ft)	Height m (ft)	Bucket Width mm (ft)	Maximum Speeds km/h (mph)	
									Forward	Reverse
AD30	CXR	02-05	304 (408)	28 870 (63,647)	30 000 (66,139)	10.15 (33'4")	2.60 (8'6")	2690* (8'10")	40.8 (25.4)	7.8 (4.8)
AD40	1YZ	94-02	380 (510)	38 100 (84,000)	40 000 (88,200)	10.66 (35'0")	2.70 (8'10")	3000 (9'10")	48.1 (29.9)	10.6 (6.6)
AD40 Series II	N/A	N/A	380 (510)	41 800 (92,170)	40 000 (88,200)	11.265 (37'0")	2.89 (9'6")	3200 (10'5")	41.7 (25.9)	9.6 (6.0)
AD45	BKZ	01-05	439 (589)	39 359 (86,772)	45 000 (99,208)	11.19 (36'9")	2.82 (9'5")	3000* (9'10")	52.0 (32.3)	10.7 (6.6)
AD55	DNW	04-07	485 (650)	47 000 (103,617)	55 000 (121,254)	11.55 (37'11")	3.20 (10'6")	3346* (11'0")	42.29 (26.3)	9.02 (5.6)

### Underground Mining — Rigid Frame Trucks

69D Dump	9XS	00-04	380 (510)	30 100 (66,371)	38 000 (83,790)	8.127 (26'8")	3.442 (11'4")	3665 (12'0")	76.6 (47.6)	76.6 (47.6)
69D Ejector	9XS	00-04	380 (510)	34 700 (78,514)	36 200 (79,821)	7.83 (25'8")	3.442 (11'4")	3665 (12'0")	13.5 (8.4)	13.5 (8.4)

\*Overall width less body.

# ESTIMATING OWNING & OPERATING COSTS

## Owning & Operating (O&O) Baseline Cost Estimate Solutions

The O&O web site provides information related to O&O baseline cost estimate development for both commercial engine products and machines. Approved O&O baseline cost estimate ranges for machines, and links related to O&O baseline cost development are also available. **NOTE:** Access to the web sites indicated below is restricted to Caterpillar and Cat dealer personnel.

For information about O&O costs, enter the appropriate link for your location.

**For Asia Pacific Division (APD):** <http://apdnet.cat.com>

Select "Product Support," "Equipment Management Solutions," "Owning and Operating Costs."

**For Corporate Global Mining (CGM):** <http://catminer.cat.com>

Select "Product Support," "Equipment Management," "MARC's," "BUILDER Downloads."

**For Europe, Africa, Middle East (EAME):** (O&O link not supported).

**For Latin America Commercial Division (LACD):** <http://lacd.cat.com>

Select "Product Support," "Equipment Management Solutions," "Owning and Operating Costs."

**For North American Commercial Division (NACD):** <https://nacd.cat.com/infocast/frames/home>

Select "Product Support Service Fulfillment (Parts and Service)," "Equipment Management Solutions," "Owning and Operating Cost Information," "Link to O&O Baseline Cost Estimate Solutions."

## CONTENTS

Estimating Form . . . . .	20-2
Explanation of Form:	
Estimating Owning Costs . . . . .	20-5
Typical Application Descriptions . . . . .	20-5
① Delivered Price to the Customer . . . . .	20-6
② Residual Value at Replacement . . . . .	20-6
③ Value to be Recovered through Work . . . . .	20-7
④ Interest . . . . .	20-7
⑤ Insurance . . . . .	20-7
⑥ Taxes . . . . .	20-7
⑧ Fuel Consumption, Fuel Tables . . . . .	20-8
⑨ Planned Maintenance Costs . . . . .	20-31
⑩ Tires:	
Tire Life Estimator Curves . . . . .	20-32
Goodyear Life Estimating System . . . . .	20-35
⑩ Undercarriage . . . . .	20-36
Basic Factors, "Z" Factors, Conditions and Multipliers . . . . .	20-36
⑪ Repair Costs . . . . .	20-38
⑫ Special Wear Items . . . . .	20-40
⑮ Operator's Hourly Wage . . . . .	20-40
O&O Cost Examples	
Example I: Track-Type Tractor . . . . .	20-40
Example II: Wheel Loader . . . . .	20-42
O&O Form with Example Figures . . . . .	20-43

## General

Machine users must balance productivity and costs to achieve optimum performance ... that is, achieve the desired production at the lowest possible cost. The approach most often used to measure machine performance is this simple equation:

$$\frac{\text{Lowest Possible Hourly Costs}}{\text{Highest Possible Hourly Productivity}} = \frac{\text{Top Machine Performance}}{\text{Performance}}$$

Most sections of this Handbook deal with the productivity of Cat machines. This section considers the cost aspect of performance.

Hourly Owning and Operating Costs for a given machine can vary widely because they are influenced by many factors: the type of work the machine does, the ownership period, local prices of fuel and labor, the repair and maintenance costs, shipping costs from the factory, interest rates, etc. No attempt is made in this handbook to provide precise hourly costs for each model. Users must be able to estimate with a reasonable degree of accuracy what a machine will cost per hour to own and operate in a given application and locality. Therefore, this section provides a suggested method of estimating hourly owning and operating costs. When this method is coupled with local conditions and dealer input, it will result in reasonable estimates.

The method suggested follows several basic principles:

- Repair and Planned Maintenance cost per hour are developed jointly by the customer and local Cat dealer.
- In the examples, labor is assumed @ \$60.00 per hour, fuel @ \$1.25 per gallon. For reliable estimates, these costs must always be obtained locally.
- Because of different standards of comparison, what may seem a high application to one machine owner may appear only medium to another.
- Unless otherwise specified, the word "hour" when used in this section means clock or operating hours, not Service Meter Units.

**HOURLY OWNING AND OPERATING COST ESTIMATE**

DATE \_\_\_\_\_

Estimate #1                      Estimate #2

A—Machine Designation . . . . . \_\_\_\_\_  
 B—Estimated Ownership Period (Years) . . . . . \_\_\_\_\_  
 C—Estimated Usage (Hours/Year) . . . . . \_\_\_\_\_  
 D—Ownership Usage (Total Hours)(B × C) . . . . . \_\_\_\_\_

**OWNING COSTS**

1. a. Delivered Price (P), to the Customer (including attachments) . . . . . \_\_\_\_\_  
 b. Less Tire Replacement Cost if desired . . . . . \_\_\_\_\_  
 c. Delivered Price Less Tires . . . . . \_\_\_\_\_

2. Less Residual Value at Replacement (S) . . . . . (\_\_\_\_%) \_\_\_\_\_ (\_\_\_\_%) \_\_\_\_\_  
 (See subsection 2A on back)

3. a. Net Value to be recovered through work . . . . . \_\_\_\_\_  
 (line 1c less line 2)

b. Cost Per Hour:  

$$\frac{\text{Net Value}}{\text{Total Hours}} \quad (1) \text{ _____ } (2) \text{ _____}$$

4. Interest Costs  $\frac{P(N + 1) + S(N - 1)}{2N} \times \text{Simple Int. \% Rate}$   
 N = No. Yrs. \_\_\_\_\_ Hours/Year = \_\_\_\_\_  
 (1)  $\frac{\text{____} + 1 + \text{____} - 1}{2} \times \text{____ \%}$  (2)  $\frac{\text{____} + 1 + \text{____} - 1}{2} \times \text{____ \%}$   
 \_\_\_\_\_ = \_\_\_\_\_ = \_\_\_\_\_  
 \_\_\_\_\_ Hours/Yr.                      \_\_\_\_\_ Hours/Yr.

5. Insurance  $\frac{P(N + 1) + S(N - 1)}{2N} \times \text{Insurance \% Rate}$   
 N = No. Yrs. \_\_\_\_\_ Hours/Year = \_\_\_\_\_  
 (1)  $\frac{\text{____} + 1 + \text{____} - 1}{2} \times \text{____ \%}$  (2)  $\frac{\text{____} + 1 + \text{____} - 1}{2} \times \text{____ \%}$   
 \_\_\_\_\_ = \_\_\_\_\_ = \_\_\_\_\_  
 \_\_\_\_\_ Hours/Yr.                      \_\_\_\_\_ Hours/Yr.

(Optional method when Insurance cost per year is known)

Ins. \$ \_\_\_\_\_ Per Yr. ÷ \_\_\_\_\_ Hours/Yr. = \_\_\_\_\_

Estimate #1

Estimate #2

6. Property Tax  $\frac{P(N + 1) + S(N - 1)}{2N} \times \text{Tax Rate \%}$   
 N = No. Yrs. \_\_\_\_\_ =  
 Hours/Year

(1)  $\frac{\text{___} + 1}{\text{___}} + \frac{\text{___} - 1}{\text{___}} \times \text{___ \%}$  (2)  $\frac{\text{___} + 1}{\text{___}} + \frac{\text{___} - 1}{\text{___}} \times \text{___ \%}$   
 \_\_\_\_\_ = \_\_\_\_\_ =  
 \_\_\_\_\_ Hours/Yr. \_\_\_\_\_ Hours/Yr.

(Optional method when Property Tax cost per year is known)

Property Tax \$ \_\_\_\_\_ Per Yr.  $\div$  \_\_\_\_\_ Hours/Yr. =

7. TOTAL HOURLY OWNING COST  
 (add lines 3b, 4, 5 and 6) .....

**OPERATING COSTS**

8. Fuel: Unit Price  $\times$  Consumption  
 (1) \_\_\_\_\_  $\times$  \_\_\_\_\_ =  
 (2) \_\_\_\_\_  $\times$  \_\_\_\_\_ =

9. Planned Maintenance (PM)-Lube Oils, Filters, Grease, Labor:  
 (contact your local Cat dealer) .....

10. a. Tires: Replacement Cost  $\div$  Life in Hours  
 $\frac{\text{Cost}}{\text{Life}}$  (1) \_\_\_\_\_ (2) \_\_\_\_\_ .....

b. Undercarriage  
 (Impact + Abrasiveness + Z Factor)  $\times$  Basic Factor  
 (1) ( \_\_\_\_\_ + \_\_\_\_\_ + \_\_\_\_\_ ) = \_\_\_\_\_  $\times$  \_\_\_\_\_ =  
 (2) ( \_\_\_\_\_ + \_\_\_\_\_ + \_\_\_\_\_ ) = \_\_\_\_\_  $\times$  \_\_\_\_\_ =  
 (Total) (Factor)

11. Repair Cost (Per Hour)  
 (contact your local Cat dealer) .....

12. Special Wear Items: Cost  $\div$  Life .....    
 (See subsection 12A on back)

13. TOTAL OPERATING COSTS  
 (add lines 8, 9, 10a (or 10b), 11 and 12) .....

14. MACHINE OWNING PLUS OPERATING  
 (add lines 7 and 13) .....

15. OPERATOR'S HOURLY WAGE (include fringes) .....

16. TOTAL OWNING AND OPERATING COST .....

**SUBSECTION 2A: Residual Value at Replacement**

Gross Selling Price	(est. #1) (___%) _____	(est. #2) (___%) _____
Less: a. Commission	_____	_____
b. Make-ready costs	_____	_____
c. Inflation during ownership period*	_____	_____
Net Residual Value	_____ (___%)	_____ (___%) of original delivered price
(Enter on line 2)		

\*When used equipment auction prices are used to estimate residual value, the effect of inflation during the ownership period should be removed to show in constant value what part of the asset must be recovered through work.

**SUBSECTION 12A: Special Items (cutting edges, ground engaging tools, bucket teeth, etc.)**

(1)	Cost	Life	Cost/Hour	(2)
1.	_____ ÷ _____	= _____	1.	_____ ÷ _____ = _____
2.	_____ ÷ _____	= _____	2.	_____ ÷ _____ = _____
3.	_____ ÷ _____	= _____	3.	_____ ÷ _____ = _____
4.	_____ ÷ _____	= _____	4.	_____ ÷ _____ = _____
5.	_____ ÷ _____	= _____	5.	_____ ÷ _____ = _____
6.	_____ ÷ _____	= _____	6.	_____ ÷ _____ = _____
	Total	(1) _____	(2) _____	

(Enter total on line 12)

1-7

**ESTIMATING OWNING COSTS***(Line Items 1 through 7)*

To protect their equipment investment and be able to replace it, the machine owner must recover over the ownership period an amount equal to the loss in resale value plus the other costs of owning the equipment including interest, insurance and taxes.

The machine owner, for accounting purposes, estimates resale value loss in advance, and recovers his original equipment investment by establishing depreciation schedules according to the various uses of the equipment. Proper financial and tax assistance is highly recommended when establishing depreciation schedules.

Considering today's economic conditions worldwide and the trend toward larger, more expensive equipment, many users choose to keep these units on the job well after they have been fully depreciated for tax purposes. On the other hand, tax incentives in many areas may favor trading a machine well before that occurs.

The ownership period in years, the hours per year, and the total number of hours on a machine, are significant factors in determining O&O costs. Additionally, since the ownership period and machine hours can vary widely for different customers for a given model, it is not practical to calculate O&O costs using an assumed ownership period. The customer must provide that information for each situation.

These same factors will be used to develop the Repair costs and Planned Maintenance costs by your local Cat dealer.

**The machine depreciation method suggested in this handbook is not based on or related to any tax considerations, but rather is a simple straight line write-off based solely on the number of years and hours the owner expects to use during the ownership period.**

**Accordingly, it is imperative that careful consideration be given the selection of depreciation periods, and that for owning and operating cost calculations they be based on actual ownership periods and hours on the machine rather than tax write-off life.**

**Typical Application Descriptions**

The following tables show typical descriptions for work performed by each product family for three different application levels. It is only a guide and can be used along with the fuel and tire charts to help determine fuel and tire cost factors. Additionally, many times the ownership period and the number of hours per year a machine is used, is related to application.

- ① Delivered Price To Customer
- ② Residual Value at Replacement

1

### DELIVERED PRICE TO CUSTOMER

*(Line Item 1a, b and c)*

Delivered price should include all costs of putting a machine on the user's job including transportation and any applicable sales taxes.

On rubber tired machines, tires are considered a wear item and covered as an operating expense. Accordingly, some users may wish to deduct tire costs from the delivered price particularly for larger machines.

2

### RESIDUAL VALUE AT REPLACEMENT

*(Line Item 2 and Subsection 2A)*

Any piece of earthmoving machinery will have some residual value at trade-in. While many owners prefer to depreciate their equipment to zero value, others recognize the residual resale or trade-in value. This is at the estimator's option, but as in the discussion of depreciation, today's higher equipment costs almost dictate that resale value be considered in determining the net depreciable investment. And if machines are traded early for tax incentive purposes, resale value becomes even more significant.

For many owners, potential resale or trade-in value is a key factor in their purchasing decisions, since this is a means of reducing the investment they must recover through depreciation charges. The high resale value of Caterpillar built machines can reduce hourly depreciation charges, lower total hourly owning costs and improve the owner's competitive position.

When resale or trade-in value is used in estimating hourly owning and operating costs, local conditions must be considered, as used equipment values vary widely around the world. However, in any given used equipment business, factors which have greatest influence on resale or trade-in value are: age of machine (years), the number of hours on the machine at the time of sale or trade, the type of jobs and operating conditions in which it worked, and the physical condition of the machine. Your local Cat dealer is your best source for determining current used equipment values.

Subsection 2A can be used to calculate the estimated residual value. If recent auction prices for used machines are used as a guide, then the value (or percentage) should be adjusted downward to remove the effect of inflation. Governmental indices on construction equipment costs or Dealer price records can be used to calculate the amount of inflation for the appropriate useful life. Another way to estimate residual value is comparing the current used machine value to the current new machine price provided major product changes haven't occurred.

③ Value to be Recovered Through Work

④ Interest

⑤ Insurance

⑥ Taxes

Owning & Operating Costs

**3** VALUE TO BE RECOVERED THROUGH WORK

(Line Item 3a and b)

The delivered price (P) less the estimated residual value (S) results in the value to be recovered through work, divided by the total usage hours, gives the hourly cost to protect the asset's value.

**4** INTEREST

(Line Item 4)

Many owners charge interest as part of hourly owning and operating costs, others consider it as general overhead in their overall operation. When charged to specific machines, interest is usually based on the owner's average annual investment in the unit.

Interest is considered to be the cost of using capital. The interest on capital used to purchase a machine must be considered, whether the machine is purchased outright or financed.

If the machine will be used for N years (where N is the number of years of use), calculate the average annual investment during the use period and apply the interest rate and expected annual usage:

$$\frac{\left[ \frac{P(N + 1) + S(N - 1)}{2N} \right] \times \text{Simple Int. \% Rate}}{\text{Hours/Year}}$$

**5-6** INSURANCE AND TAXES

(Line Items 5 and 6)

Insurance cost and property taxes can be calculated in one of two ways. If the specific annual cost is known, this figure should be divided by the estimated usage (hours/years) and used. However, when the specific interest and tax costs for each machine are not known, the following formulas can be applied:

$$\frac{\frac{\text{Insurance}}{N = \text{No. Years}} \times \frac{\left[ \frac{P(N + 1) + S(N - 1)}{2N} \right] \times \text{Insurance \% Rate}}{\text{Hours/Year}}}{\text{Hours/Year}}$$

$$\frac{\frac{\text{Property Tax}}{N = \text{No. Years}} \times \frac{\left[ \frac{P(N + 1) + S(N - 1)}{2N} \right] \times \text{Tax Rate \%}}{\text{Hours/Year}}}{\text{Hours/Year}}$$



8-13

**ESTIMATING OPERATING COSTS***(Line Items 8 through 13)*

8

**FUEL CONSUMPTION***(Line Item 8)*

Actual fuel consumption should be measured in the field. However, if no opportunity exists to do this, consumption can be estimated when the machine application is known.

Application determines engine load factor and engine fuel consumption. Engine load factor refers to the instantaneous loading of the engine relative to its maximum capability. An engine continuously producing full rated horsepower is operating at a load factor of 100%. Earthmoving machines may reach a 100% load factor intermittently, but seldom operate at this level for extended periods of time. Periods spent at idle, dozer and pusher travel in reverse, haul units traveling empty, close maneuvering at part throttle and operating downhill are examples of conditions which reduce load factor.

The following tables provide hourly fuel consumption estimates at various load factors. Engine load factors are to be used as a general guide and will vary by model and application. Since machine uses vary, application guides are also provided to aid in estimating load factor.

To estimate hourly fuel cost, select the load factor based on application and find hourly consumption. Then:

$$\text{Hourly consumption} \times \text{Local Unit Price of Fuel} = \text{Hourly Fuel Cost}$$

**When using these tables, keep in mind the many variables which can affect fuel consumption. Two operators of different temperament or attitude operating identical machines side by side in the same material can have as much as 10-12% difference in their consumption rates. Actual results may vary from the ranges shown because they are created to cover a wide spectrum of operating conditions. Your Cat dealer representative can help select the most reasonable estimate for your specific situation; we suggest you call on him.**

**Keep in mind also that a fuel consumption study measured over a short period of operation will give higher fuel consumption than shown here because: (1) the study will be at 100% productivity, without breaks or idle time, and (2) the operators will know they're being measured and therefore may not use their normal operating techniques. On the other hand, these tables allow for "normal" inefficiencies in the working cycle and will more closely relate to "normal" day to day operation.**

FUEL CONSUMPTION TABLES AND LOAD FACTOR GUIDES

TRACK-TYPE TRACTORS

Model	Low		Medium		High	
	liter	U.S. gal	liter	U.S. gal	liter	U.S. gal
D3K	—	—	7.9	2.1	—	—
D4K	—	—	8.6	2.3	—	—
D5K	—	—	9.0	2.4	—	—
D5N	6.5-11.5	1.5-3.5	11.5-16.0	3.5-4.5	13.75-18.5	3.75-5.0
D6G	12.0-17.0	3.2-4.5	17.0-22.0	4.5-5.8	22.0-27.6	5.8-7.3
D6K	9.9-14.9	2.6-3.9	14.9-21.5	3.9-5.7	19.8-26.4	5.2-7.0
D6N	12.1-16.5	3.2-4.3	13.8-21.4	3.6-5.6	18.7-26.4	4.9-6.9
D6R Series 3 (138 kW/185 hp)	13.6-19.7	3.6-5.2	19.7-25.7	5.2-6.8	25.7-31.4	6.8-8.3
D6R Series 3 (149 kW/200 hp)	15.5-22.3	4.1-5.9	22.3-29.1	5.9-7.7	29.1-35.6	7.7-9.4
D6T (138 kW/185 hp)	15.5-22.3	4.1-5.9	22.3-28.8	5.9-7.6	28.8-35.6	7.6-9.4
D6T (149 kW/200 hp)	15.9-22.7	4.2-6.0	22.7-29.5	6.0-7.8	29.5-36.3	7.8-9.6
D7E	14.8-20.8	3.9-5.5	20.8-27.2	5.5-7.2	27.2-34.5	7.2-9.1
D7G	16.0-22.5	4.5-6.0	22.5-29.0	6.0-8.0	29.0-35.5	8.0-9.5
D7R Series 2	—	—	24.6-31.4	6.5-8.3	31.4-39.0	8.3-10.3
D8R	22.5-32.0	6.0-8.5	32.0-41.5	8.5-11.0	41.5-51.0	11.0-13.5
D8T Tier 3	23.5-33.7	6.2-8.9	33.7-43.5	8.9-11.5	43.9-53.7	11.6-14.2
D9T Tier 3	30.3-43.1	8.0-11.4	43.1-56.4	11.4-14.9	56.4-69.3	14.9-18.3
D10T	42.8-60.1	11.3-16.1	60.1-79.5	16.1-21.0	79.5-97.7	21.0-25.8
D11R	61.0-87.0	16.5-23.0	87.0-113.0	23.0-30.0	113.0-139.5	30.0-37.0
D11T	59.0-84.4	15.6-22.3	84.4-109.8	22.3-29.0	109.8-135.1	29.0-35.7

\*D7G fuel consumption data is based on a precombustion chamber equipped engine. Fuel consumption for a direct injection equipped D7G should be approximately 10% less.

**Typical Application Description**

(relative to work application)

- Low Pulling scrapers, most agricultural drawbar, stockpile, coal pile and finish grade applications. No impact. Intermittent full throttle operation.
- Medium Production dozing in clays, sands, gravels. Push loading scrapers, borrow pit ripping, most land clearing applications. Medium impact conditions. Production landfill work.
- High Heavy rock ripping. Push loading and dozing in hard rock. Working on rock surfaces. Continuous high impact conditions.

**Load Factor Guide**

(average engine load factor based on application description for each range)

- Low 35%-50%
- Medium 50%-65%
- High 65%-80%

**Product Link Information** — Product link measured over hundreds of Track-Type Tractors shows that more than 90% of the machines experience an average fuel consumption equal to or lower than those shown in the Medium Application profile.

**MOTOR GRADERS**

Model	Low		Medium		High	
	liter	U.S. gal	liter	U.S. gal	liter	U.S. gal
120K	9.0-12.9	2.4-3.4	12.9-16.7	3.4-4.4	16.7-20.6	4.4-5.4
120M	10.2-14.6	2.7-3.9	14.6-19.0	3.9-5.0	19.0-23.3	5.0-6.2
12K	10.9-15.2	2.9-4.1	15.5-20.2	4.1-5.3	20.2-24.8	5.3-6.6
12M	11.0-15.7	2.9-4.2	15.7-20.4	4.2-5.4	20.4-25.1	5.4-6.6
140K	12.3-17.6	3.3-4.7	17.6-23.0	4.7-6.1	23.0-28.2	6.1-7.5
140M	13.5-16.4	3.6-4.3	16.4-21.3	4.3-5.6	21.3-30.9	5.6-8.2
160K	14.0-20.0	3.7-5.3	20.0-26.0	5.3-6.9	26.0-32.0	6.9-8.5
160M	14.6-17.8	3.9-4.7	17.8-23.1	4.7-6.1	23.1-33.5	6.1-8.8
14M	15.7-22.4	4.1-5.9	22.4-29.1	5.9-7.7	29.1-39.8	7.7-10.5
16M	20.4-29.1	5.4-7.7	29.1-37.9	7.7-10.0	37.9-46.6	10.0-12.3
24M	36.0-49.2	9.5-13.0	49.2-68.1	13.0-18.0	68.1-83.3	18.0-22.0

**Typical Application Description**

(relative to work application)

- Low Light road maintenance. Finish grading. Plant and road mix work. Large amounts of traveling. Light snow plowing.
- Medium Haul road maintenance. Average road maintenance, road mix work, scarifying. Road construction, ditching, loose fill spreading. Land forming, land leveling and elevating grader use. Medium to heavy snow removal.
- High Heavy maintenance of hard packed roads with embedded rock. Heavy fill spreading, base material spreading and ditching. Ripping/scarifying of asphalt or concrete. Continuous high load factor. High impact. Heavy snow plowing.

**Load Factor Guide**

(average engine load factor based on application description for each range)

- Low 35%-50%
- Medium 50%-65%
- High 65%-80%

**SKID STEER LOADERS, MULTITERRAIN LOADERS AND COMPACT TRACK LOADERS**

Model	Low		Medium		High	
	liter	U.S. gal	liter	U.S. gal	liter	U.S. gal
216B2	3.98-5.69	<b>1.05-1.50</b>	5.69-7.40	<b>1.50-1.95</b>	7.40-9.11	<b>1.95-2.41</b>
226B2	5.89-8.42	<b>1.56-2.22</b>	8.42-10.94	<b>2.22-2.89</b>	10.94-13.47	<b>2.89-3.56</b>
232B2	5.89-8.42	<b>1.56-2.22</b>	8.42-10.94	<b>2.22-2.89</b>	10.94-13.47	<b>2.89-3.56</b>
236B2	5.59-7.98	<b>1.48-2.11</b>	7.98-10.37	<b>2.11-2.74</b>	10.37-12.77	<b>2.74-3.37</b>
242B2	5.89-8.42	<b>1.56-2.22</b>	8.42-10.94	<b>2.22-2.89</b>	10.94-13.47	<b>2.89-3.56</b>
246C	5.59-7.98	<b>1.48-2.11</b>	7.98-10.37	<b>2.11-2.74</b>	10.37-12.77	<b>2.74-3.37</b>
247B2	5.89-8.42	<b>1.56-2.22</b>	8.42-10.94	<b>2.22-2.89</b>	10.94-13.47	<b>2.89-3.56</b>
256C	6.12-8.74	<b>1.62-2.31</b>	8.74-11.36	<b>2.31-3.00</b>	11.36-13.98	<b>3.00-3.69</b>
257B2	5.89-8.42	<b>1.56-2.22</b>	8.42-10.94	<b>2.22-2.89</b>	10.94-13.47	<b>2.89-3.56</b>
262C	6.12-8.74	<b>1.62-2.31</b>	8.74-11.36	<b>2.31-3.00</b>	11.36-13.98	<b>3.00-3.69</b>
272C	6.78-9.69	<b>1.79-2.56</b>	9.69-12.59	<b>2.56-3.33</b>	12.59-15.50	<b>3.33-4.09</b>
277C	6.12-8.74	<b>1.62-2.31</b>	8.74-11.36	<b>2.31-3.00</b>	11.36-13.98	<b>3.00-3.69</b>
279C	6.12-8.74	<b>1.62-2.31</b>	8.74-11.36	<b>2.31-3.00</b>	11.36-13.98	<b>3.00-3.69</b>
287C	6.12-8.74	<b>1.62-2.31</b>	8.74-11.36	<b>2.31-3.00</b>	11.36-13.98	<b>3.00-3.69</b>
289C	6.12-8.74	<b>1.62-2.31</b>	8.74-11.36	<b>2.31-3.00</b>	11.36-13.98	<b>3.00-3.69</b>
297C	6.78-9.69	<b>1.79-2.56</b>	9.69-12.59	<b>2.56-3.33</b>	12.59-15.50	<b>3.33-4.09</b>
299C	6.78-9.69	<b>1.79-2.56</b>	9.69-12.59	<b>2.56-3.33</b>	12.59-15.50	<b>3.33-4.09</b>

**Typical Application Description**

(relative to work application)

- Low Light utility, construction, nursery and landscaping applications. Load and carry of free flowing, low density materials on firm, smooth surfaces for short distances with minimal grades. Light snow removal.
- Medium Industrial and construction job site applications. Loading from bank or load and carry of low to medium density materials on normal surfaces with low to medium rolling resistance and slight adverse grades. Occasional use of various attachments under normal loading conditions.
- High Continuous industrial, construction and batch plant applications. Loading from tight banks or load and carry of high density materials on rough or very soft surfaces with high rolling resistance and adverse grades. Maximum use of high flow attachments under high loading conditions.

**Load Factor Guide**

(average engine load factor based on application description for each range)

- Low 35%-50%
- Medium 50%-65%
- High 65%-80%

## Owning & Operating Costs

- ⑧ Hourly Fuel Consumption Tables
- Articulated Trucks (Underground)
- Load Haul Dump Units (LHD'S) (Underground)

### ARTICULATED TRUCKS (Underground)

Model	Low		Medium		High	
	liter	U.S. gal	liter	U.S. gal	liter	U.S. gal
AD30	27.0-38.0	7.1-10.0	38.0-45.0	10.0-11.9	45.0-56.0	11.9-14.8
AD45B	35.0-45.0	9.2-11.9	45.0-55.0	11.9-14.5	55.0-65.0	14.5-17.2
AD55B	45.0-55.0	11.9-14.5	55.0-65.0	14.5-17.2	65.0-80.0	17.2-21.1

#### Typical Application Description

(relative to work application)

- Low Continuous operation at <80% of maximum recommended gross weight. Short to medium haul distances: 300-1000 m (**990-3300 feet**). Well maintained, level haul roads. Considerable amount of idling. Very few tray impacts. Low load factor.
- Medium Intermittent operation at less than maximum recommended gross weight. Medium to longer haul distances: 1000-5000 m (**3300-16,000 feet**). Varying haul road conditions with some adverse grades. Occasional tray impacts. Medium load factor.
- High Continuous operation at maximum recommended gross weight. Long haul distances: >5000 m (**>16,000 feet**). Poor haul road conditions with adverse/steep grades. Frequent tray impacts. High load factor.

#### Load Factor Guide

(average engine load factor based on application description for each range)

- Low 20%-40%
- Medium 40%-60%
- High 60%-80%

### LOAD HAUL DUMP UNITS (LHD'S) (Underground)

Model	Low		Medium		High	
	liter	U.S. gal	liter	U.S. gal	liter	U.S. gal
R1300G	11.3-15.1	3.0-4.0	15.1-18.9	4.0-5.0	18.9-30.2	5.0-6.0
R1600G	15.1-22.7	4.0-6.0	22.7-28.3	6.0-7.5	28.3-39.7	7.5-10.5
R1700G	22.7-26.4	6.0-7.0	26.4-34.0	7.0-9.0	34.0-45.4	9.0-12.0
R2900G	30.2-37.8	8.0-10.0	37.8-45.4	10.0-12.0	45.4-56.7	12.0-15.0
R2900G XTRA	33.0-40.0	8.7-10.5	40.0-47.0	10.5-12.4	47.0-59.0	12.4-15.6

#### Typical Application Description

(relative to work application)

- Low Dig and carry operation from stockpiles to ground level transfer station. Low density, free flowing ore and waste. Excellent draw point floor surfaces. Short haul distances: 25-100 m (**80-330 feet**). Level roads with good surface conditions. Low load factor.
- Medium Intermittent development/production loading into trucks/transfer station. Good digging with well shot, low to medium density ore and waste. Average draw point floor surfaces. Medium haul distances: 100-200 m (**330-660 feet**). Poor road surfaces with slightly adverse grades. Medium load factor.
- High Continuous production loading of trucks at or near maximum load height. Difficult digging. Loading haul trucks. Rough draw point surfaces. Long haul distances: 200-300 m (**660-990 feet**). Poor haul roads with adverse grades. High load factor.

#### Load Factor Guide

(average engine load factor based on application description for each range)

- Low 20%-40%
- Medium 40%-60%
- High 60%-80%

**EXCAVATORS**

Model	Low		Medium		High	
	liter	U.S. gal	liter	U.S. gal	liter	U.S. gal
301.5	2.1-2.5	<b>0.55-0.66</b>	2.5-2.9	<b>0.66-0.77</b>	2.9-3.3	<b>0.77-0.87</b>
301.6C	0.9-1.4	<b>0.24-0.35</b>	1.4-1.8	<b>0.35-0.47</b>	1.8-2.3	<b>0.47-0.59</b>
301.8C	0.9-1.4	<b>0.24-0.35</b>	1.4-1.8	<b>0.35-0.47</b>	1.8-2.3	<b>0.47-0.59</b>
302.5C	1.2-1.8	<b>0.31-0.47</b>	1.8-2.4	<b>0.47-0.62</b>	2.4-3.0	<b>0.62-0.78</b>
303 CR/SR	3.4-4.0	<b>0.89-1.07</b>	4.0-4.7	<b>1.07-1.24</b>	4.7-5.4	<b>1.2-1.42</b>
304 CR	4.0-4.8	<b>1.06-1.28</b>	4.8-5.6	<b>1.28-1.49</b>	5.6-6.4	<b>1.49-1.7</b>
305 CR/SR	4.7-5.7	<b>1.24-1.49</b>	5.7-6.6	<b>1.49-1.74</b>	6.6-7.5	<b>1.74-1.99</b>
307D	2.5-3.7	<b>0.7-1.0</b>	3.7-4.9	<b>1.0-1.3</b>	4.9-6.2	<b>1.3-1.6</b>
308D CR	2.5-3.7	<b>0.7-1.0</b>	3.7-4.9	<b>1.0-1.3</b>	4.9-6.2	<b>1.3-1.6</b>
311D RR (Tier 3)	3.5-6.5	<b>0.9-1.7</b>	6.5-9.5	<b>1.7-2.5</b>	9.5-12.8	<b>2.5-3.4</b>
312D (Tier 3)	4.0-7.5	<b>1.1-2.0</b>	7.5-11.5	<b>2.0-3.0</b>	11.5-15.2	<b>3.0-4.0</b>
314D CR (Tier 3)	4.0-7.5	<b>1.1-2.0</b>	7.5-11.5	<b>2.0-3.0</b>	11.5-15.2	<b>3.0-4.0</b>
315D (Tier 3)	5.0-9.5	<b>1.3-2.5</b>	9.5-14.5	<b>2.5-3.8</b>	14.5-19.2	<b>3.8-5.1</b>
319D (Tier 3)	5.5-10.5	<b>1.5-2.8</b>	10.5-15.5	<b>2.8-4.1</b>	15.5-21.0	<b>4.1-5.5</b>
320D (STD Tier 3)	6.0-12.0	<b>1.6-3.2</b>	12.0-18.0	<b>3.2-4.8</b>	18.0-24.0	<b>4.8-6.3</b>
320D (HHP Tier 3)	6.5-12.5	<b>1.7-3.3</b>	12.5-18.5	<b>3.3-4.9</b>	18.5-24.8	<b>4.9-6.6</b>
321D CR (STD Tier 3)	6.0-12.0	<b>1.6-3.2</b>	12.0-18.0	<b>3.2-4.8</b>	18.0-24.0	<b>4.8-6.3</b>
321D CR (HHP Tier 3)	6.5-12.5	<b>1.7-3.3</b>	12.5-18.5	<b>3.3-4.9</b>	18.5-24.8	<b>4.9-6.6</b>
323D (Tier 3)	6.5-12.5	<b>1.7-3.3</b>	12.5-18.5	<b>3.3-4.9</b>	18.5-24.8	<b>4.9-6.6</b>
324D (STD Tier 3)	7.0-14.0	<b>1.8-3.7</b>	14.0-21.0	<b>3.7-5.5</b>	21.0-28.0	<b>5.5-7.4</b>
324D (HHP Tier 3)	8.0-16.0	<b>2.1-4.2</b>	16.0-24.0	<b>4.2-6.3</b>	24.0-32.0	<b>6.3-8.5</b>
324D (STD Tier 2)	6.5-13.5	<b>1.7-3.6</b>	13.5-20.0	<b>3.6-5.3</b>	20.0-26.6	<b>5.3-7.0</b>
324D (HHP Tier 2)	7.5-15.5	<b>2.0-4.1</b>	15.5-23.0	<b>4.1-6.1</b>	23.0-30.4	<b>6.1-8.0</b>
328D CR (Tier 3)	8.5-17.5	<b>2.2-4.6</b>	17.5-26.0	<b>4.6-6.9</b>	26.0-34.5	<b>6.9-9.1</b>
329D (STD Tier 3)	8.0-16.0	<b>2.1-4.2</b>	16.0-24.0	<b>4.2-6.3</b>	24.0-32.0	<b>6.3-8.5</b>
329D (HHP Tier 3)	8.5-17.5	<b>2.2-4.6</b>	17.5-26.0	<b>4.6-6.9</b>	26.0-34.5	<b>6.9-9.1</b>
329D (STD Tier 2)	7.5-15.5	<b>2.0-4.1</b>	15.5-23.0	<b>4.1-6.1</b>	23.0-30.5	<b>6.1-8.1</b>
329D (HHP Tier 2)	8.5-16.5	<b>2.2-4.4</b>	16.5-24.5	<b>4.4-6.5</b>	24.5-33.0	<b>6.5-8.7</b>
336D (Tier 3)	11.5-23.0	<b>3.0-6.1</b>	23.0-34.5	<b>6.1-9.1</b>	34.5-45.5	<b>9.1-12.0</b>
336D (Tier 2)	11.0-21.5	<b>2.9-5.7</b>	21.5-32.5	<b>5.7-8.6</b>	32.5-43.5	<b>8.6-11.5</b>
345D (Tier 3)	15.5-30.5	<b>4.1-8.1</b>	30.5-45.6	<b>8.1-12.0</b>	45.6-61.0	<b>12.0-16.1</b>
345D (Tier 2)	14.5-29.0	<b>3.8-7.7</b>	29.0-43.3	<b>7.7-11.4</b>	43.3-58.0	<b>11.4-15.3</b>
365C (Tier 3)	16.5-33.0	<b>4.4-8.7</b>	33.0-49.2	<b>8.7-13.0</b>	49.2-65.5	<b>13.0-17.3</b>
365C (Tier 2)	15.5-31.0	<b>4.1-8.2</b>	31.0-46.7	<b>8.2-12.3</b>	46.7-62.5	<b>12.3-16.5</b>
374D (Tier 3)	19.0-37.5	<b>5.0-9.9</b>	37.5-56.4	<b>9.9-14.9</b>	56.4-75.5	<b>14.9-19.9</b>
374D (Tier 2)	18.0-35.5	<b>4.8-9.4</b>	35.5-53.6	<b>9.4-14.2</b>	53.6-71.5	<b>14.2-18.9</b>
385C (Tier 3)	20.5-41.0	<b>5.4-10.8</b>	41.1-61.0	<b>10.8-16.1</b>	61.0-81.5	<b>16.1-21.5</b>
385C (Tier 2)	19.5-39.0	<b>5.2-10.3</b>	39.0-58.0	<b>10.3-15.3</b>	58.0-77.5	<b>15.3-20.5</b>
M313D	8.0-12.0	<b>2.1-3.2</b>	12.0-16.0	<b>3.2-4.2</b>	16.0-19.0	<b>4.2-5.0</b>
M315D	9.0-13.0	<b>2.4-3.4</b>	13.0-18.0	<b>3.4-4.8</b>	18.0-21.0	<b>4.8-5.5</b>
M316D	8.0-12.0	<b>2.1-3.2</b>	12.0-17.0	<b>3.2-4.5</b>	17.0-20.0	<b>4.5-5.3</b>
M318D	9.0-13.0	<b>2.4-3.4</b>	13.0-18.0	<b>3.4-4.8</b>	18.0-22.0	<b>4.8-5.8</b>
M322D	11.0-17.0	<b>2.9-4.5</b>	17.0-23.0	<b>4.5-6.1</b>	23.0-26.0	<b>6.0-6.9</b>
M325C MH*	12.9-15.9	<b>3.4-4.2</b>	20.8-23.8	<b>5.5-6.3</b>	23.8-27.6	<b>6.3-7.3</b>
M325C L MH*	14.0-19.0	<b>3.7-5.0</b>	23.0-27.0	<b>6.1-7.1</b>	27.0-32.0	<b>7.1-8.5</b>
W330B MH*	19.0-24.0	<b>5.0-6.3</b>	29.0-33.0	<b>7.7-8.7</b>	34.0-39.0	<b>9.0-10.3</b>
W345B MH*	25.0-30.0	<b>6.6-7.9</b>	38.0-42.0	<b>10.0-11.1</b>	45.0-50.0	<b>11.9-13.2</b>

\*If the application of these machines is to be used for scrap handling, the LOW hourly fuel consumption rate would typically apply.  
NOTE: Fuel consumption rates for 320D through 385C include machine at idle per load factor definition.

**Mini HEX**

**Typical Application Description**

(relative to work application)

- Low Mostly shallow depth urban utility construction where excavator sets pipe and digs in sandy loam or free flowing, low density material. Little traveling and little or no impact.
- Medium Most residential pipeline and cabling applications. Continuous mass excavation and trenching in natural bed clay soils. Some traveling and steady, full throttle operation.
- High Continuous trenching or truck loading in rock or shot rock soils. Most pipeline applications in hard rocky material. Large amount of travel over rough ground. Constant high load factor and high impact.

**Load Factor Guide**

(average engine load factor based on application description for each range)

- Low 20%-40%
- Medium 40%-60%
- High 60%-80%

**300 Series**

**Typical Application Description**

(relative to work application)

- Low Mostly shallow depth urban utility construction where excavator sets pipe and digs less than 50% of the daily work schedule. Sandy loam, free flowing, low density material. Most scrap handling applications. Little traveling and little or no impact.
- Medium Most residential sewer applications. Continuous mass excavation and trenching in natural bed clay soils. Digging 60-85% of the daily work schedule. Most log loading applications. Some traveling and steady, full throttle operation.
- High Continuous trenching or truck loading in rock or shot rock soils. Most pipeline applications in hard rocky material. Digging 90-95% of the daily work schedule. Large amount of travel over rough ground. Working on rock floor with constant high load factor and high impact.

**Load Factor Guide**

(average engine load factor based on application description for each range)

- Low 20%-40%
- Medium 40%-60%
- High 60%-80%

**M Series**

**Typical Application Description**

(relative to work application)

- Low Urban utility construction application in sandy loam, low density material. Digging less than 50% of the daily work schedule. Rehandling and scrap handling applications.
- Medium Residential sewer applications in natural bed clay. Continuous digging in sandy clay/gravel. Digging 60-85% of the daily work schedule. Site development and lumber yard applications. Most logging applications.
- High Pipeline applications in hard rocky material. Continuous digging in rock/natural bed clay. Digging 90-95% of the daily work schedule. High impact, using hammer, working in forests and quarries.

**Load Factor Guide**

(average engine load factor based on application description for each range)

- Low 20%-40%
- Medium 40%-60%
- High 60%-80%

**FRONT SHOVELS**

Model	Low		Medium		High	
	liter	U.S. gal	liter	U.S. gal	liter	U.S. gal
5090	43.0-48.0	11.4-12.7	62.0-68.0	16.4-18.0	71.0-78.0	18.8-20.6
5130B (Tier 1)	—	—	120.2	31.6	160.3	42.2
5230B (Tier 1)	—	—	232.5	61.2	310.0	81.6

**Typical Application Description**

(relative to work application)

- Low Continuous loading in loose banks or stockpile. Light, easy work with, considerable idling. Good underfoot conditions.
- Medium Continuous loading in well-shot rock or fairly tight bank. Steady cycling with frequent periods of idle. Good underfoot conditions; dry floor, little impact or sliding on undercarriage. Minimal travel time (3%-6%).
- High Continuous loading in poorly-shot rock, virgin or lightly-blasted tight banks. Steady cycling in hard to dig material. Adverse underfoot conditions; rough floors, high impact and/or sliding on undercarriage.

**Load Factor Guide**

(average engine load factor based on application description for each range)

- Low 20%-50%
- Medium 50%-80%
- High 80%-100%

**PIPELAYERS**

Model	Low		Medium		High	
	liter	U.S. gal	liter	U.S. gal	liter	U.S. gal
PL61	5.7-11.7	1.5-3.0	9.7-15.1	2.5-4.0	13.2-18.9	3.5-5.0
572R Series 2	8.5-12.3	2.2-3.3	12.3-15.7	3.3-4.2	15.7-19.5	4.2-5.2
583T	11.8-16.9	3.1-4.5	16.9-21.8	4.5-5.8	21.8-26.8	5.8-7.1
587R	11.8-16.0	3.1-4.2	16.0-20.8	4.2-5.5	20.8-25.5	5.5-6.8
587T	15.3-21.9	4.0-5.8	21.9-28.3	5.8-7.5	28.3-34.9	7.5-9.2

**Typical Application Description**

(relative to work application)

- Low Little or no use in mud, water or on rock. Use on level, regular surfaces.
- Medium Typical pipelayer use in operating conditions ranging from very good to severe.
- High Continuous use in deep mud or water or on rock surfaces.

**Load Factor Guide**

(average engine load factor based on application description for each range)

- Low 35%-50%
- Medium 50%-65%
- High 65%-80%



- Wheel Tractor-Scrapers
- Backhoe Loaders

**WHEEL TRACTOR-SCRAPERS**

Model	Low		Medium		High	
	liter	U.S. gal	liter	U.S. gal	liter	U.S. gal
613G Tier 3	15.0-19.0	4.0-5.0	21.0-25.0	5.5-6.5	27.5-34.0	7.3-9.0
621G Tier 3	26.3-37.6	6.9-9.9	37.6-48.8	9.9-12.9	48.8-60.1	12.9-15.9
623G Tier 3	30.1-41.3	8.0-10.9	41.3-52.6	10.9-13.9	52.6-66.1	13.9-17.5
627G Tier 3	40.2-59.9	10.6-15.8	59.9-79.5	15.8-21.0	79.5-104.7	21.0-27.7
631G Tier 3	33.9-48.5	9.0-12.8	48.5-63.0	12.8-16.6	63.0-77.5	16.6-20.5
637G Tier 3	48.8-72.4	12.9-19.1	72.4-95.9	19.1-25.3	95.9-125.3	25.3-33.1
657G Tier 3	66.3-98.6	17.6-26.1	98.6-130.9	26.1-34.6	130.9-163.3	34.6-43.1

**Typical Application Description**

(relative to work application)

- Low Level or favorable grades on good haul roads and low rolling resistance. Easy-loading materials, partial loads. No impact. Average use, but with considerable idling.
- Medium Adverse and favorable grades with varying loading and haul road conditions. Long and short hauls, near full. Some impact. Typical road building use.
- High Rough haul roads. Loading heavy clay, continuous high total resistance conditions with steady cycling. Overloading. High impact conditions, such as loading ripped rock.

**Load Factor Guide**

(average engine load factor based on application description for each range)

- Low 35%-50%
- Medium 50%-65%
- High 65%-80%

**BACKHOE LOADERS**

Model	Low		Medium		High	
	liter	U.S. gal	liter	U.S. gal	liter	U.S. gal
416D (NA)	6.4-8.3	1.7-2.2	8.3-10.2	2.2-2.7	10.2-12.1	2.7-3.2
416D (T)	7.6-9.5	2.0-2.5	9.5-11.4	2.5-3.0	11.4-13.2	3.0-3.5
416E	7.6-9.5	2.0-2.5	9.5-11.4	2.5-3.0	11.4-13.2	3.0-3.5
420E (T)	7.0	1.8	11.0	2.9	18.1	4.8
422E (T)	6.4-8.3	1.7-2.2	8.3-10.2	2.2-2.7	10.2-12.1	2.7-3.2
424D (NA)	6.4-8.3	1.7-2.2	8.3-10.2	2.2-2.7	10.2-12.1	2.7-3.2
428E (T)	7.6-9.5	2.0-2.5	9.5-11.4	2.5-3.0	11.4-13.2	3.0-3.5
430E (T)	7.7	2.0	12.8	3.4	20.4	5.4
432E (T)	8.1-10.0	2.1-2.6	10.0-11.9	2.6-3.1	11.9-14.2	3.1-3.8
434E (T)	8.1-10.0	2.1-2.6	10.0-11.9	2.6-3.1	11.9-14.2	3.1-3.8
438D	8.9-11.2	2.4-3.0	11.2-13.1	3.0-3.5	13.1-15.3	3.5-4.0
442E (T)	8.9-11.2	2.4-3.0	11.2-13.1	3.0-3.5	13.1-15.3	3.5-4.0
444E (T)	8.9-11.2	2.4-3.0	11.2-13.1	3.0-3.5	13.1-15.3	3.5-4.0
446D (T)	10.6-12.9	2.8-3.4	12.9-15.1	3.4-4.0	15.1-17.4	4.0-4.6
450E	17.0	4.5	17.0	4.5	21.9	5.8

NA = Naturally Aspirated  
T = Turbocharged

- Backhoe Loaders
- Forest Products

**Backhoe Loaders**

**Typical Application Description**

(relative to work application)

Low Light duty utility applications with intermittent cycles in light to medium soil. Trenching depths less than 1.83 m (**6 feet**).

Medium General utility applications with regular cycles in medium to heavy soil. Dig depths to 3.05 m (**10 feet**). Occasional use of constant flow implements.

High Production applications or digging in rock. Dig depths over 3.05 m (**10 feet**). Long cycle times or regular use of constant flow implements.

**Load Factor Guide**

(average engine load factor based on application description for each range)

Low 20%-30%

Medium 30%-40%

High 40%-50%

**FOREST PRODUCTS**

Model	Low		Medium		High	
	liter	U.S. gal	liter	U.S. gal	liter	U.S. gal
<b>FOREST MACHINES</b>						
320D FM	11.5-14.0	<b>3.0-3.7</b>	17.0-19.0	<b>4.5-5.0</b>	20.5-22.5	<b>5.4-6.0</b>
322C LL	25.0-28.0	<b>6.5-7.5</b>	26.0-29.0	<b>7.0-7.5</b>	27.0-30.0	<b>7.5-8.0</b>
324D FM	14.0-19.0	<b>3.7-5.1</b>	23.0-27.0	<b>6.1-7.1</b>	27.0-32.0	<b>7.2-8.5</b>
325C LL	26.0-29.0	<b>7.0-7.5</b>	27.0-30.0	<b>7.0-8.0</b>	29.0-32.0	<b>7.5-8.5</b>
325D FM	14.0-19.0	<b>3.7-5.1</b>	23.0-27.0	<b>6.1-7.1</b>	27.0-32.0	<b>7.2-8.5</b>
330C LL	36.0-40.0	<b>9.5-10.5</b>	37.0-41.0	<b>10.0-11.0</b>	38.0-42.0	<b>10.0-11.0</b>
330D FM	19.0-24.0	<b>5.0-6.3</b>	29.0-33.0	<b>7.7-8.7</b>	34.0-39.0	<b>9.0-10.3</b>
<b>FELLER BUNCHERS</b>						
511 (2290)	25.0-28.0	<b>6.5-7.5</b>	28.0-34.0	<b>7.5-9.0</b>	36.0-42.0	<b>9.5-11.0</b>
521 (2390)	27.0-33.0	<b>7.0-8.5</b>	33.0-36.0	<b>8.5-9.5</b>	36.0-44.0	<b>9.5-11.5</b>
522 (2391)	27.0-33.0	<b>7.0-8.5</b>	33.0-36.0	<b>8.5-9.5</b>	36.0-44.0	<b>9.5-11.5</b>
532 (2491)	28.0-34.0	<b>7.5-9.0</b>	34.0-38.0	<b>9.0-10.0</b>	38.0-45.0	<b>10.0-12.0</b>
541 (2590)	28.0-34.0	<b>7.5-9.0</b>	34.0-38.0	<b>9.0-10.0</b>	38.0-45.0	<b>10.0-12.0</b>
551	28.0-34.0	<b>7.5-9.0</b>	34.0-38.0	<b>9.0-10.0</b>	38.0-45.0	<b>10.0-12.0</b>
552	30.0-34.0	<b>8.0-9.0</b>	34.0-40.0	<b>9.0-10.5</b>	40.0-49.0	<b>10.5-13.0</b>
<b>TRACK SKIDDERS</b>						
517	5.7-13.2	<b>1.5-3.5</b>	13.2-18.9	<b>3.5-5.0</b>	15.0-22.7	<b>4.0-6.0</b>
527	13.2-18.9	<b>3.5-5.0</b>	18.9-23.6	<b>5.0-6.25</b>	23.6-32.2	<b>6.25-8.5</b>
<b>WHEEL SKIDDERS</b>						
525B	10.4-15.1	<b>2.75-4.0</b>	15.1-20.8	<b>4.0-5.5</b>	20.8-32.2	<b>5.5-8.5</b>
535B	10.4-15.1	<b>2.75-4.0</b>	15.1-22.7	<b>4.0-6.0</b>	22.7-34.0	<b>6.0-9.0</b>
545	10.4-15.1	<b>2.75-4.0</b>	15.1-24.6	<b>4.0-6.5</b>	24.6-37.8	<b>6.5-10.0</b>
<b>KNUCKLEBOOM LOADERS</b>						
539	26.0-29.0	<b>6.87-7.66</b>	27.0-30.0	<b>7.13-7.93</b>	29.0-32.0	<b>7.66-8.45</b>
<b>HARVESTERS</b>						
550	*	*	*	*	*	*
570	*	*	*	*	*	*
580	*	*	*	*	*	*
<b>FORWARDERS</b>						
554	*	*	*	*	*	*
574	*	*	*	*	*	*
584	12.0	<b>3.18</b>	14.0	<b>3.70</b>	16.0	<b>4.24</b>

\*Insufficient data.

**Wheel Skidders**

**Typical Application Description**

(relative to work application)

- Low Intermittent skidding for short distances, no decking. Good underfoot conditions; dry floor, few if any stumps, flat/level terrain with low skidding resistance.
- Medium Continuous turning, steady skidding for medium distances with moderate decking. Good underfoot conditions; dry floor with few stumps, gradual rolling/moderate terrain with medium skidding resistance.
- High Continuous turning, steady skidding for long distances with frequent decking. Poor underfoot conditions; wet floor, numerous stumps, steep terrain with high skidding resistance.

**Load Factor Guide — 517**

- Low Skidding loads less than 4536 kg (**10,000 lb**) in flat terrain (0-8% grade) with low skidding resistance.
- Medium Skidding loads up to 4536 kg (**10,000 lb**) in moderate terrain (8-30% grade) with medium skidding resistance.
- High Skidding loads over 4536 kg (**10,000 lb**) in steep terrain (over 30% grade) with high skidding resistance.

**Load Factor Guide — 525B**

- Low Skidding loads less than 4500 kg (**10,000 lb**) in flat terrain (0-5% grade) with low skidding resistance.
- Medium Skidding loads up to 6800 kg (**15,000 lb**) in moderate terrain (5-10% grade) with average skidding resistance.
- High Skidding loads over 6800 kg (**15,000 lb**) in steep terrain (over 10% grade) with high skidding resistance.

**Load Factor Guide — 527**

- Low Skidding loads less than 6360 kg (**14,000 lb**) in flat terrain (0-8% grade) with low skidding resistance.
- Medium Skidding loads up to 6360 kg (**14,000 lb**) in moderate terrain (8-30% grade) with medium skidding resistance.
- High Skidding loads over 6360 kg (**14,000 lb**) in steep terrain (over 30% grade) with high skidding resistance.

**Feller Bunchers**

**Typical Application Description**

(relative to work application)

- Low Harvesting application or intermittent felling and stacking in good underfoot conditions. Flat ground, uniform trees below 255 mm (**10 inches**).
- Medium Harvesting or hot saw application in medium underfoot conditions. Rolling terrain, some trees up to 457 mm (**18 inches**) or some hardwoods.
- High High cycling in poor underfoot conditions, steep terrain, over stumps or fallen trees. Multiple small diameter trees or larger trees 508 mm (**20 inches**) or larger hardwoods.

**Load Factor Guide**

(average engine load factor based on application description for each range)

- Low 45%-65%
- Medium 66%-85%
- High 86%-98%

**Forwarders**

**Typical Application Description**

(relative to work application)

- Low Loading and hauling application in good conditions. Flat ground, concentrated log bunches, single tier log lengths, short haul distances
- Medium Loading and hauling application in medium conditions. Rolling terrain, medium spacing of log bunches, single and two tier log lengths.
- High Loading and hauling application in poor conditions, steep or rocky terrain, scattered log bunches, two tier log lengths, long haul distances.

**Load Factor Guide**

(average engine load factor based on application description for each range)

- Low 15%-25%
- Medium 25%-35%
- High 35%-45%

**OFF HIGHWAY TRUCKS**

Model	Low		Medium		High	
	liter	U.S. gal	liter	U.S. gal	liter	U.S. gal
770	20.4-30.6	5.4-8.1	30.6-40.8	8.1-10.8	40.8-51.0	10.8-13.5
772	23.6-35.3	6.2-9.3	35.3-47.1	9.3-12.4	47.1-58.9	12.4-15.6
773E	27.4-41.2	7.2-10.9	41.2-54.9	10.9-14.5	54.9-68.6	14.5-18.1
773F	28.3-42.5	7.5-11.2	42.5-56.6	11.2-15.0	56.6-70.8	15.0-18.7
775F	28.7-43.1	7.6-11.4	43.1-57.4	11.4-15.2	57.4-71.8	15.2-19.0
777D	37.5-56.3	9.9-14.9	56.3-75.0	14.9-19.8	75.0-93.8	19.8-24.8
777F	37.1-55.7	9.8-14.7	55.7-74.2	14.7-19.6	74.2-92.8	19.6-24.5
785C	53.7-80.6	14.2-21.3	80.6-107.5	21.3-28.4	107.5-134.4	28.4-35.5
785D	54.2-81.4	14.3-21.5	81.4-108.5	21.5-28.7	108.5-135.6	28.7-35.8
789C	70.6-105.9	18.7-28.0	105.9-141.2	28.0-37.3	141.2-176.5	37.3-46.6
793D	90.8-136.2	24.0-36.0	136.2-181.6	36.0-48.0	181.6-227.0	48.0-60.0
793F	96.7-145.0	25.5-38.3	145.0-193.3	38.3-51.1	193.3-241.7	51.1-63.9
797F	146.8-220.3	38.8-58.2	220.3-293.7	58.2-77.6	293.7-367.1	77.6-97.0

NOTE: Load factors above 50% may be experienced in many applications.

**Typical Application Description**

(relative to work application)

- Low Continuous operation at an average gross weight less than recommended. Excellent haul roads. No overloading, low load factor.
- Medium Continuous operation at an average gross weight approaching recommended. Minimal overloading, good haul roads, moderate load factor.
- High Continuous operation at or above maximum recommended gross weight. Overloading, poor haul roads, high load factor.

**Load Factor Guide**

(average engine load factor based on application description for each range)

- Low 20%-30%
- Medium 30%-40%
- High 40%-50%

**ARTICULATED TRUCKS**

Model	Low		Medium		High	
	liter	U.S. gal	liter	U.S. gal	liter	U.S. gal
725	10.6-14.8	<b>2.8-3.9</b>	14.8-20.8	<b>3.9-5.5</b>	20.8-30.1	<b>5.5-8.0</b>
730 Ejector	12.3-17.1	<b>3.3-4.5</b>	17.1-24.5	<b>4.5-6.4</b>	24.2-34.9	<b>6.4-9.2</b>
730	11.7-16.3	<b>3.1-4.3</b>	16.3-23.0	<b>4.3-6.1</b>	23.0-33.2	<b>6.1-8.8</b>
735	16.6-23.1	<b>4.4-6.1</b>	23.1-32.4	<b>6.1-8.6</b>	32.4-46.8	<b>8.6-12.4</b>
740	16.7-23.2	<b>4.4-6.1</b>	23.2-32.6	<b>6.1-8.6</b>	32.6-47.1	<b>8.6-12.5</b>
740 Ejector	17.5-24.4	<b>4.6-6.4</b>	24.4-34.2	<b>6.4-8.6</b>	34.2-49.5	<b>9.0-13.1</b>

**Typical Application Description**

(relative to work application)

- Low Earthmoving and stockpile use with well matched loading equipment, free flowing material. Large amount of idling, short to medium haul distances on well-maintained level haul roads. Minimum total resistance, few impact loads.
- Medium Typical use in road-building, dam construction, open-pit mining, etc. Normal load and haul times, varying haul road conditions with some adverse grades. Some impact loads.
- High Poorly-matched loading equipment with continuous overloading. Long haul time and continuous use on very poorly maintained haul roads with frequent adverse grades. High rolling resistance, poor traction, high impact loads.

**Load Factor Guide**

(average engine load factor based on application description for each range)

- Low 20%-30%
- Medium 30%-40%
- High 40%-50%

**TELEHANDLERS**

Model	Low		Medium		High	
	liter	U.S. gal	liter	U.S. gal	liter	U.S. gal
TH210	5.1-6.8	1.3-1.8	8.5-10.1	2.2-2.6	11.8-13.5	3.1-3.5
TH215	5.1-6.8	1.3-1.8	8.5-10.1	2.2-2.6	11.8-13.5	3.1-3.5
TH220B (59-74 kW/80-99 hp)	5.0-7.0	1.3-1.8	10.0-14.0	2.6-3.7	13.0-17.0	3.4-4.5
TH220B (92 kW/123 hp)	5.0-8.0	1.3-2.1	10.0-16.0	2.6-4.2	13.0-20.0	3.4-5.3
TH330B (59-74 kW/80-99 hp)	5.0-7.0	1.3-1.8	10.0-14.0	2.6-3.7	13.0-17.0	3.4-4.5
TH330B (92 kW/123 hp)	5.0-8.0	1.3-2.1	10.0-16.0	2.6-4.2	13.0-20.0	3.4-5.3
TH340B	5.0-7.0	1.3-1.8	10.0-14.0	2.6-3.7	13.0-17.0	3.4-4.5
TH350B	5.0-7.0	1.3-1.8	10.0-14.0	2.6-3.7	13.0-17.0	3.4-4.5
TH355B	5.0-7.0	1.3-1.8	10.0-14.0	2.6-3.7	13.0-17.0	3.4-4.5
TH360B	5.0-7.0	1.3-1.8	10.0-14.0	2.6-3.7	13.0-17.0	3.4-4.5
TH460B	5.0-7.0	1.3-1.8	10.0-14.0	2.6-3.7	13.0-17.0	3.4-4.5
TH560B (59-74 kW/80-99 hp)	5.0-9.0	1.3-2.4	10.0-15.0	2.6-4.0	13.0-17.5	3.4-4.6
TH560B (92 kW/123 hp)	5.0-9.0	1.3-2.4	10.0-17.0	2.6-4.5	13.0-21.0	3.4-5.5
TH580B	5.0-6.0	1.3-1.6	9.0-10.7	2.4-2.8	16.0-18.3	4.2-4.8

**Typical Application Description**

(relative to work application)

Low Light to moderate, intermittent, utility applications with frequent periods of idling and limited travel.

Medium General construction applications with moderate amounts of travel.

High Continuous production applications with near capacity loading and extended lifts.

**Load Factor Guide**

(average engine load factor based on application description for each range)

Low 20%-30%

Medium 30%-40%

High 40%-50%

**WHEEL DOZERS/SOIL COMPACTORS/LANDFILL COMPACTORS**

Model	Low		Medium		High	
	liter	U.S. gal	liter	U.S. gal	liter	U.S. gal
814F	21.0-25.0	5.5-6.5	26.0-30.0	7.0-8.0	36.0-40.0	9.5-10.5
815F	26.0-30.0	7.0-8.0	36.0-42.0	9.5-11.0	44.0-47.0	11.5-12.5
816F	26.0-30.0	7.0-8.0	36.0-42.0	9.5-11.0	44.0-47.0	11.5-12.5
824H	28.9-33.8	7.9-8.9	39.8-45.8	10.5-12.1	53.7-59.7	14.2-15.8
825H	37.8-43.8	10.0-11.6	53.7-67.3	14.2-17.8	63.7-69.7	16.8-18.4
826H	34.0-35.8	8.4-9.4	39.8-43.8	10.5-11.6	47.8-51.7	12.6-13.6
834H	34.6-43.4	9.1-11.4	48.2-52.2	12.7-13.8	67.6-74.0	17.8-19.5
836H	39.8-43.8	10.5-11.6	47.8-51.7	12.6-14.0	55.7-59.7	14.7-18.0
844	42.0-50.0	11.0-13.0	54.0-62.0	14.0-16.0	65.0-73.0	17.0-19.0
854G	53.0-61.0	14.0-16.0	68.0-76.0	18.0-20.0	83.0-91.0	22.0-24.0

**Wheel Dozers**

**Typical Application Description**

(relative to work application)

- Low Light utility and stockpile work. Pulling compactors. Dozing loose fill. Considerable idling or travel with no load and no impact.
- Medium Production dozing, push loading in clays, sands, silts, loose gravels. Shovel clean-up. Normal compaction.
- High Heavy production dozing in rock. Push-loading in rocky, bouldery borrow pits. Heavy landfill compactor work. High impact conditions.

**Load Factor Guide**

(average engine load factor based on application description for each range)

- Low 35%-50%
- Medium 50%-65%
- High 65%-80%

**Soil Compactors/Landfill Compactors**

**Typical Application Description**

(relative to work application)

- Low No dozing or very light spreading on a flat or downhill surface. Machine has support equipment dozing and spreading trash while compactor simply travels over flat surface multiple times.
- Medium Compactor primary use is compacting already spread material. Compactor assists in dozing and spreading during peak periods of day and possibly working slopes of no steeper than a 4:1.
- High Compactor is possibly only machine for operation. Machine will doze and spread material alone and then compact it with multiple passes working on steep slopes and possibly uphill.

**Load Factor Guide**

(average engine load factor based on application description for each range)

- Low 35%-50%
- Medium 50%-65%
- High 65%-80%

**COMPACTION EQUIPMENT**

Model	Low		Medium		High	
	liter	U.S. gal	liter	U.S. gal	liter	U.S. gal
CP-323C	8.0-13.0	2.0-3.5	11.0-15.0	3.0-4.0	11.0-19.0	3.0-5.0
CS-323C	8.0-13.0	2.0-3.5	11.0-15.0	3.0-4.0	11.0-19.0	3.0-5.0
CS-423E	11.0-13.0	3.0-3.5	11.0-17.0	3.0-4.5	13.0-19.0	3.5-5.0
CS-431C	8.0-11.0	2.0-3.0	11.0-13.0	3.0-3.5	11.0-15.0	3.0-4.0
CP-44	5.8-7.8	1.5-2.1	7.8-11.9	2.1-3.1	11.9-15.7	3.1-4.2
CS-44	5.8-7.8	1.5-2.1	7.8-11.9	2.1-3.1	11.9-15.7	3.1-4.2
CS-531D	11.0-13.0	3.0-3.4	12.0-14.0	3.2-3.7	13.0-16.0	3.4-4.2
CP-533E	10.0-12.0	2.64-3.17	11.0-13.0	2.9-3.4	12.0-15.0	3.2-4.0
CS-533E	10.0-12.0	2.64-3.17	11.0-13.0	2.9-3.4	12.0-15.0	3.2-4.0
CP-563E	12.0-14.0	3.2-3.7	14.0-17.0	3.7-4.5	17.0-20.0	4.5-5.3
CS-563E	12.0-14.0	3.2-3.7	14.0-17.0	3.7-4.5	17.0-20.0	4.5-5.3
CP-573E	12.0-15.0	3.2-4.0	14.0-18.0	3.7-4.8	17.0-21.0	4.5-5.6
CS-573E	12.0-15.0	3.2-4.0	14.0-18.0	3.7-4.8	17.0-21.0	4.5-5.6
CS-583E	15.0-17.0	4.0-4.5	17.0-19.0	4.5-5.0	19.0-23.0	5.0-6.0
CP-663E	15.0-17.0	4.0-4.5	17.0-19.0	4.5-5.0	21.0-22.5	5.5-6.0
CS-663E	15.0-17.0	4.0-4.5	17.0-19.0	4.5-5.0	21.0-22.5	5.5-6.0
CS-683E	17.0-19.0	4.5-5.0	19.0-21.0	5.0-5.5	22.5-24.5	6.0-6.5
CB-214D	2.0-3.0	0.5-1.0	2.5-3.5	0.5-1.0	3.0-4.0	1.0-1.5
CB-224D	2.0-4.0	0.5-1.0	3.0-4.0	0.5-1.0	3.5-4.5	1.0-1.5
CB-225D	2.0-3.0	0.5-1.0	2.5-3.5	0.5-1.0	3.0-4.0	1.0-1.5
CB-334E	3.8-5.7	1.0-1.5	5.7-7.0	1.5-1.8	7.0-10.0	1.8-2.6
CB-335E	3.5-5.5	0.9-1.4	5.5-6.5	1.4-1.7	6.5-9.0	1.7-2.4
CB-434C	11.0-13.0	3.0-3.5	13.0-17.0	3.5-4.5	17.0-19.0	4.5-5.0
CB-434D	5.7-7.6	1.5-2.0	7.6-11.4	2.0-3.0	11.4-15.2	3.0-4.0
CB-534D	5.7-7.6	1.5-2.0	7.6-11.4	2.0-3.0	11.4-15.2	3.0-4.0
CB-54	8.5	2.2	9.4	2.5	11.0	2.9
CB-562D	5.7-7.6	1.5-2.0	7.6-11.4	2.0-3.0	11.4-15.2	3.0-4.0
CB-564D	8.55	2.26	10.45	2.76	13.3	3.51
CB-64	8.5	2.2	9.4	2.5	11.0	2.9
CB-634C	13.0	3.5-4.0	15.0-19.0	4.0-5.0	19.0-21.0	5.0-5.5
PS-150C	8.0-11.0	2.0-3.0	11.0-13.0	3.0-3.5	13.0-15.0	3.5-4.0
PS-200B	11.0	3.0	11.0-13.0	3.0-3.5	13.0-15.0	3.5-4.0
PF-300C	13.0	3.5	15.0-17.0	4.0-4.5	17.0-23.0	4.5-6.0
PS-300C	13.0	3.5	15.0-17.0	4.0-4.5	17.0-23.0	4.5-6.0
PS-360C	17.4-9.8	1.9-2.6	9.8-12.4	2.6-3.3	12.4-14.5	3.3-4.6



**Asphalt Compactors**

**Typical Application Description**

(relative to work application)

Low Asphalt mix, 25-50 mm **(1-2 inch)** lifts. Static finish rolling, all lifts.

Medium Asphalt mix, 51-100 mm **(2-4 inch)** lifts.

High Asphalt mix, 101-150 mm **(4-6 inch)** lifts. Prepare granular base lifts.

**Vibratory Soil Compactors**

**Typical Application Description**

(relative to work application)

Low Granular soil not compacted to high density (<95 Proctor). Residential street work with lift thicknesses from 51-100 mm **(2-4 inch)** working the initial compaction. Level ground, minimal slopes and intermittent periods of waiting for base work completion or material delivery. Speeds in the middle of the low range (2-3 km/h [1-2 mph]). Minimal start and stop of the vibe function.

Medium Granular soil compacted to density (>95 Proctor). Cohesive soils with padded drum and low/normal moisture content, blading <25%. Continuous operation on thicker lifts 101-200 mm **(4-8 inch)** or doing the final passes on stiffer materials or working at the top end of the low speed range. Working on slopes greater than 5% or rapid directional changes combined with start and stop of the vibe function.

High Cohesive soil with padded drum and high moisture content. Combined high load factors from the medium duty application. Working on thick lifts 201-300 mm **(8-12 inch)**, slopes greater than 15%, or applications requiring significant blade work. An example would be trench work with backfilling.

**Load Factor Guide**

(average engine load factor based on application description for each range)

Low Vibration 20-40%

Medium Vibration 40-60%

High Vibration 60-100%

**Pneumatic Compactors**

**Typical Application Description**

(relative to work application)

Low Asphalt mix, all lifts. Intermediate or finish rolling, chip seal. Level ground.

Medium Asphalt mix, all lifts. Intermediate or finish rolling. Granular base breakdown <100 mm **(<4 inch)**. Moderate grade.

High Granular base or cold in place breakdown roller >100 mm **(4 inch)** lifts. Intermediate or finish rolling. Steep grades.

**Load Factor Guide**

(average engine load factor based on application description for each range)

Low Vibration 30%-50%

Medium Vibration 50%-80%

High Vibration 80%-100%

**COMPACTION EQUIPMENT — UTILITY COMPACTORS**

Model	Low		Medium		High	
	liter	U.S. gal	liter	U.S. gal	liter	U.S. gal
CB14	1.6	0.42	2.0	0.53	2.3	0.61
CB22	4.0	1.06	5.5	1.45	7.0	1.85
CB24, CB24 XT	4.0	1.06	5.5	1.45	7.0	1.85
CC24	3.0	0.79	5.0	1.32	7.0	1.85
CB32	4.0	1.06	5.5	1.45	7.0	1.85
CB34, CB34 XW	2.0-3.2	0.53-0.83	3.2-4.5	0.83-1.19	4.5-6.0	1.19-1.59
CC34	2.0-3.2	0.53-0.83	3.2-4.5	0.83-1.19	4.5-6.0	1.19-1.59

**Utility Compactors — CB14, CB22, CB24, CB32, CC24**

**Typical Application Description**

(relative to work application)

Low Asphalt mix, 25-50 mm (1-2 inch) lifts. Static finish rolling, all lifts.

Medium Asphalt mix, 25-50 mm (1-2 inch) lifts. Normal working conditions with vibrate and static.

High Asphalt mix, 25-50 mm (1-2 inch) lifts. May include some soil compaction.

**Load Factor Guide**

(average engine load factor based on application description for each range)

Low Vibration 10-30%

Medium Vibration 30-60%

High Vibration 60-85%

**Utility Compactors — CB34, CC34**

**Typical Application Description**

(relative to work application)

Low Asphalt mix, 25-50 mm (1-2 inch) lifts. Static finish rolling, all lifts.

Medium Asphalt mix, 51-100 mm (2-4 inch) lifts

High Asphalt mix, 101-150 mm (4-6 inch) lifts. Prepare granular base lifts

**Load Factor Guide**

(average engine load factor based on application description for each range)

Low Vibration 20-40%

Medium Vibration 40-70%

High Vibration 80-100%

**ASPHALT PAVERS**

Model	Low		Medium		High	
	liter	U.S. gal	liter	U.S. gal	liter	U.S. gal
AP-650B (97 kW/130 hp)	20.8-24.6	5.5-6.5	24.6-28.4	6.5-7.5	32.2-36.0	8.5-9.5
AP-800D (97 kW/130 hp)	20.8-24.6	5.5-6.5	24.6-28.4	6.5-7.5	32.2-36.0	8.5-9.5
AP-500E (106 kW/142 hp)	9.0-14.0	2.4-3.7	14.0-19.0	3.7-5.0	19.0-25.0	5.0-6.6
AP-555E (106 kW/142 hp)	9.0-14.0	2.4-3.7	14.0-19.0	3.7-5.0	19.0-25.0	5.0-6.6
AP-600D (129 kW/174 hp)	13.3-19.0	3.5-5.0	19.0-24.7	5.0-6.5	32.2-36.0	8.5-9.5
AP-655D (129 kW/174 hp)	13.3-19.0	3.5-5.0	19.0-24.7	5.0-6.5	32.2-36.0	8.5-9.5
AP-1050B (129 kW/174 hp)	19.0-22.5	5.0-6.0	26.5-30.0	7.0-8.0	34.0-38.0	9.0-10.0
AP-1000D (167 kW/224 hp)	20.8-24.6	5.5-6.5	24.6-28.4	6.5-7.5	32.2-36.0	8.5-9.5
AP-1055D (167 kW/224 hp)	20.8-24.6	5.5-6.5	24.6-28.4	6.5-7.5	32.2-36.0	8.5-9.5
BG-600D (129 kW/174 hp)	13.3-19.0	3.5-5.0	19.0-24.7	5.0-6.5	32.2-36.0	8.5-9.5
BG-655D (129 kW/174 hp)	13.3-19.0	3.5-5.0	19.0-24.7	5.0-6.5	32.2-36.0	8.5-9.5
BG-245C (129 kW/174 hp)	19.0-22.5	5.0-6.0	26.5-30.0	7.0-8.0	34.0-38.0	9.0-10.0
BG-260D (167 kW/224 hp)	20.8-24.6	5.5-6.5	24.6-28.4	6.5-7.5	32.2-36.0	8.5-9.5
BG-2455D (167 kW/224 hp)	20.8-24.6	5.5-6.5	24.6-28.4	6.5-7.5	32.2-36.0	8.5-9.5

**Typical Application Description**

(relative to work application)

Low Narrow width paving, low production.

Medium 3-4 m (10-12 feet) width, 50-75 mm (2-3 inch) lift.

High Wide width, deep lift paving.

**Load Factor Guide**

(average engine load factor based on application description for each range)

Low 20%-30%

Medium 30%-40%

High 40%-50%

⑧ Hourly Fuel Consumption Tables  
 ● Cold Planers  
 ● Road Reclaimers/Soil Stabilizers

Owning & Operating Costs

**COLD PLANERS**

Model	Low		Medium		High	
	liter	U.S. gal	liter	U.S. gal	liter	U.S. gal
PM-201	45.5-60.6	<b>12.0-16.0</b>	60.6-83.4	<b>16.0-22.0</b>	83.4-106.1	<b>22.0-28.0</b>
PM-465	37.0-45.0	<b>10.0-12.0</b>	45.0-57.0	<b>12.0-15.0</b>	60.0-76.0	<b>16.0-20.0</b>
PM-565B	37.0-53.0	<b>10.0-14.0</b>	53.0-68.0	<b>14.0-18.0</b>	72.0-87.0	<b>19.0-23.0</b>

**Typical Application Description**

(relative to work application)

Low 50 mm (**2 inches**) or less cutting depth, 80% load cycle.

Medium 100 mm (**4 inches**) cutting depth.

High Steady, full depth.

**Load Factor Guide**

(average engine load factor based on application description for each range)

Low 35%-50%

Medium 50%-65%

High 65%-80%

**ROAD RECLAIMERS/SOIL STABILIZERS**

Model	Low		Medium		High	
	liter	U.S. gal	liter	U.S. gal	liter	U.S. gal
RM-250C	26.5-34.1	<b>7.0-9.0</b>	34.1-41.6	<b>9.0-11.0</b>	41.6-53.0	<b>11.0-14.0</b>
RM-300	26.5-34.1	<b>7.0-9.0</b>	34.1-41.6	<b>9.0-11.0</b>	41.6-53.0	<b>11.0-14.0</b>
RM-350B	53.1-68.2	<b>14.0-18.0</b>	68.2-83.4	<b>18.0-22.0</b>	83.4-94.8	<b>22.0-25.0</b>
RM-500	45.4-56.7	<b>12.0-15.0</b>	60.5-68.1	<b>16.0-18.0</b>	75.7-87.1	<b>20.0-23.0</b>

**Typical Application Description**

(relative to work application)

Low 150 mm (**6 inches**) soil/100 mm (**4 inches**) asphalt.

Medium 305 mm (**12 inches**) soil/150 mm (**6 inches**) asphalt.

High 457 mm (**18 inches**) soil/305 mm (**12 inches**) asphalt.

**Load Factor Guide**

(average engine load factor based on application description for each range)

Low 35%-60%

Medium 60%-80%

High 80%-90%

**TRACK LOADERS**

Model	Low		Medium		High	
	liter	U.S. gal	liter	U.S. gal	liter	U.S. gal
933C	9.0-11.0	2.5-3.0	11.0-13.0	3.0-3.5	13.0-15.0	3.5-4.0
939C	11.0-13.0	3.0-3.5	13.0-15.0	3.5-4.0	15.0-17.0	4.0-4.5
953D	12.2-19.1	3.2-5.1	19.1-24.4	5.1-6.4	24.4-29.6	6.4-7.8
963D	15.7-22.5	4.2-5.9	24.7-29.2	6.5-7.7	29.2-36.0	7.7-9.5
973D	25.9-35.5	6.8-9.4	35.5-44.3	9.4-11.7	44.3-52.1	11.7-13.8

**Typical Application Description**

(relative to work application)

- Low Site clearing of small vegetation, stripping top soil, carrying to stockpile. Backfilling and grading. Intermittent truck loading from stockpile. Free flowing, low density materials with standard bucket. Large amounts of idling. No impact.
- Medium Bank excavation, bank or stockpile loading. Intermittent ripping, basement digging of natural bed clays, sands, silts, gravels. Load and carry. Steady full throttle operation.
- High Loading shot rock, cobbles, glacial till, caliche. Continuous work on rock surfaces. Continuous excavating and loading from bank. High density materials in standard bucket. Land clearing and steel mill work. Large amount of ripping in tight, rocky materials. High impact conditions.

**Load Factor Guide**

(average engine load factor based on application description for each range)

- Low 35%-50%
- Medium 50%-65%
- High 65%-80%

**Product Link Information** — Product Link measured over hundreds of Track-Type Loaders shows that more than 90% of the machines experience an average fuel consumption equal to or lower than those shown in the Low Application profile.

**WHEEL LOADERS AND INTEGRATED TOOLCARRIERS**

Model	Low		Medium		High	
	liter	U.S. gal	liter	U.S. gal	liter	U.S. gal
904H	4.4-6.3	<b>1.16-1.66</b>	6.3-8.2	<b>1.66-2.17</b>	8.2-10.1	<b>2.17-2.67</b>
906H	3.8	<b>1.01</b>	7.6	<b>2.01</b>	11.4	<b>3.02</b>
907H	3.8	<b>1.01</b>	7.6	<b>2.01</b>	11.4	<b>3.02</b>
908H	4.3	<b>1.14</b>	8.6	<b>2.28</b>	12.9	<b>3.42</b>
914G, IT14G	5.0-6.5	<b>1.0-2.0</b>	8.0-10.5	<b>2.0-2.5</b>	11.5-13.0	<b>3.0-3.5</b>
924H, 924Hz	3.5-5.8	<b>0.9-1.5</b>	5.8-8.1	<b>1.5-2.1</b>	8.1-15.0	<b>2.1-3.9</b>
928H, 928Hz	3.8-6.2	<b>1.0-1.6</b>	6.2-8.5	<b>1.6-2.2</b>	8.5-15.4	<b>2.2-4.0</b>
930H	3.8-6.2	<b>1.0-1.6</b>	6.2-8.5	<b>1.6-2.2</b>	8.5-15.4	<b>2.2-4.0</b>
938H, IT38H*	5.2-7.8	<b>1.4-2.0</b>	7.8-10.4	<b>2.0-2.7</b>	10.4-15.0	<b>2.7-4.0</b>
950H*	7.9-11.4	<b>2.1-3.0</b>	11.4-14.7	<b>3.0-3.9</b>	14.7-18.5	<b>3.9-4.9</b>
962H, IT62H*	9.4-12.0	<b>2.5-3.2</b>	12.0-15.1	<b>3.2-4.0</b>	15.1-19.2	<b>4.0-5.1</b>
966H*	9.1-13.4	<b>2.4-3.5</b>	13.4-16.9	<b>3.5-4.5</b>	16.9-20.5	<b>4.5-5.4</b>
972H*	12.3-17.1	<b>3.3-4.5</b>	17.1-21.0	<b>4.5-5.5</b>	21.0-25.5	<b>5.5-6.7</b>
980H*	15.6-20.6	<b>4.1-5.4</b>	20.6-26.0	<b>5.4-6.9</b>	26.0-32.9	<b>6.9-8.7</b>
988H	28.0-40.1	<b>7.4-10.6</b>	40.1-52.6	<b>10.6-13.9</b>	52.6-65.1	<b>13.9-17.2</b>
990H	42.0-58.3	<b>11.1-15.4</b>	58.3-75.0	<b>15.4-19.8</b>	75.0-91.6	<b>19.8-24.2</b>
992K	53.0-75.7	<b>14.0-20.0</b>	75.7-98.4	<b>20.0-26.0</b>	98.4-121.0	<b>26.0-32.0</b>
993K	61.3-87.4	<b>16.2-23.1</b>	87.4-113.6	<b>23.1-30.0</b>	113.6-140.0	<b>30.0-37.0</b>
994F	87.0-123.0	<b>23.0-32.5</b>	123.0-160.0	<b>32.5-42.2</b>	160.0-197.0	<b>42.2-52.0</b>

\*The Medium Wheel Loader (i.e. 938H to 980H) hourly fuel rates are taken directly from customer machines registered on Product Link worldwide. Data from the top and bottom 5% of these customer machines has been excluded from the tables because it varies widely (15-60% from the extremes shown) and therefore is not considered representative of what the remaining 90% of customers experience. Hourly fuel consumption for the 90% of machines in the tables also varies depending upon geographical region, load factor variation between models, etc. Cat machines are often used in more demanding applications which can account for differences between competitive models used in lighter duty applications. Consult your local Cat dealer for ways to more accurately estimate hourly fuel consumption for specific applications.

**Compact Wheel Loaders**

**Typical Application Description**

(relative to work application)

- Low Light industrial or construction site duties. Moving light loads with bucket or pallet forks. Not continuous duty, considerable idle time. Machine could be working on average 2 hours or less per day.
- Medium Intermittent aggregate truck loading from stockpile, hopper charging or load and carry on firm, smooth surfaces for short distances with minimal grades. Free flowing, low density materials. Light utility, industrial and construction applications. Light snowplowing.
- High Continuous truck loading from stockpile and hopper charging. Loading from bank or load and carry on normal surfaces with low to medium rolling resistance and slight adverse grades. Low to medium density materials in properly sized bucket. Assumes normal travel distances associated with high productivity stockpile load-out and batch plant applications.

**Load Factor Guide**

(average engine load factor based on application description for each range)

- Low 35%-50%
- Medium 50%-65%
- High 65%-80%

**Small, Medium and Large Wheel Loaders and Integrated Toolcarriers**

**Typical Application Description**

(relative to work application)

- Low Intermittent aggregate truck loading from stockpile, hopper charging or load and carry on firm, smooth surfaces for short distances with minimal grades. Free flowing, low density materials. Light utility, industrial and construction applications. Light snowplowing. Most logging applications where there is considerable idling.
- Medium Continuous truck loading from stockpile and hopper charging. Loading from bank or load and carry on normal surfaces with low to medium rolling resistance and slight adverse grades. Low to medium density materials in properly sized bucket. Assumes normal travel distances associated with high productivity stockpile load-out and batch plant applications.
- High Loading shot rock (large loaders) from a face. Steady loading from very tight banks. Continuous work on rough or very soft surfaces with high rolling resistance. Load and carry in hard digging material with longer travel distances on poor surfaces with adverse grades. Handling high density materials with counterweighted machine.

**Small and Large Wheel Loaders**

**Load Factor Guide**

(average engine load factor based on application description for each range)

- Low 35%-50%
- Medium 50%-65%
- High 65%-80%

**Medium Wheel Loader and Integrated Toolcarrier**

**Load Factor Guide**

(average engine load factor based on application description for each range)

Fuel rates can vary for a specific load factor depending on model and application, therefore some overlap is shown in the load factor table.

- Low 15%-30%
- Medium 25%-35%
- High 30%-45%

9

**PLANNED MAINTENANCE (PM)  
LUBE OILS, FILTERS, GREASE, LABOR**

Planned Maintenance (PM) costs should be developed by the Cat dealer, with customer input for the specific application.

PM costs include the parts and labor at the intervals specified in the Operation and Maintenance Manuals provided for each machine. PM costs for each machine may vary slightly depending upon factors required or specified by the customer. See your local Cat dealer to develop the specific PM cost per hour estimate for your machine and application.



10a **TIRES**

(Line Item 10a)

Tire costs are an important part of the hourly cost of any wheel machine. Tire costs are also one of the most difficult to predict with many variables. The best estimate for tire costs are obtained when tire life estimates are based upon actual customer experience, and are used with prices the machine owner actually pays for the replacement tires.

For cases in which tire experience is not available, use the following tire life estimator curves.

**Tire Life Estimators**

- Curves do not allow for additional life from recapping. They assume new tires run to destruction, but this is not necessarily recommended.
- Based on standard machine tires. Optional tires will shift these curves either up or down.
- Sudden failure (blow out) due to exceeding Ton-MPH (tkm/h) limitations is not considered. Nor are premature failures due to puncture.
- Application Descriptions/Zones:

Low/Zone A: almost all tires actually wear through the tread from abrasion.

Medium/Zone B: tires wear out normally but others fail prematurely due to rock cuts, impacts and non-repairable punctures.

High/Zone C: few, if any, tires wear through the tread due to non-repairable damages, usually from rock cuts, impacts and continuous overloading.

**NOTE:** Tire life can often be increased by using extra tread and extra deep tread tires.

**NOTE:** Premature failure could occur at any time due to puncture.

**MOTOR GRADERS**

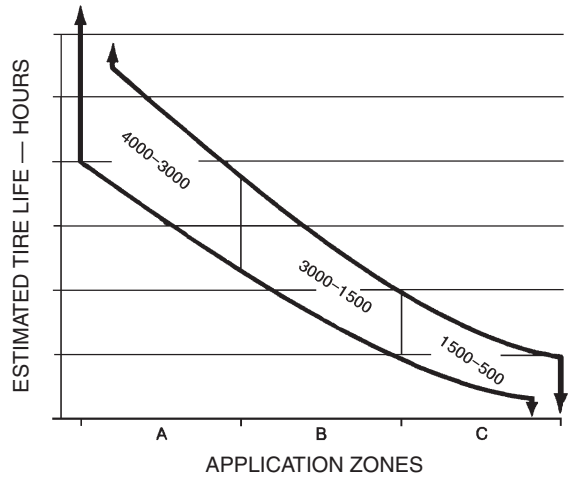

**SKIDDERS**

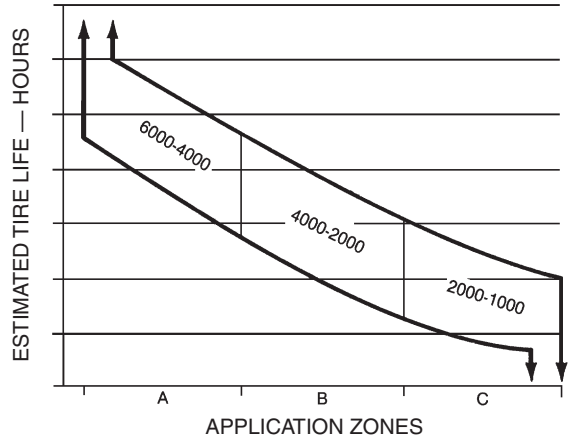

**SKID STEER LOADERS**

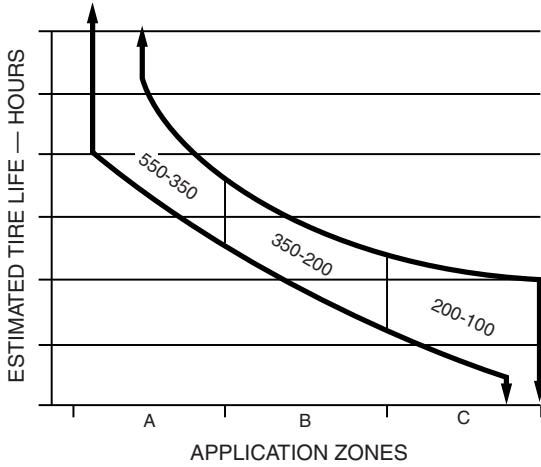

**LOAD HAUL DUMP UNITS**

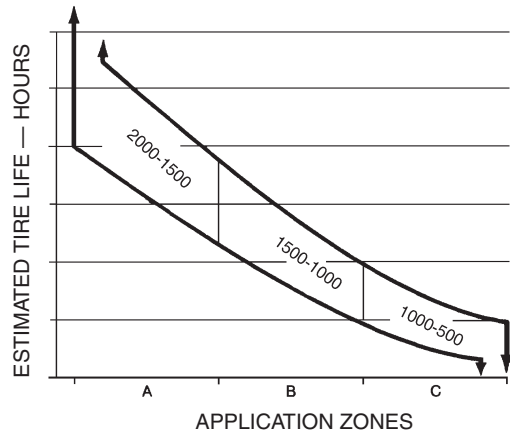

**WHEEL TRACTOR-SCRAPERS**

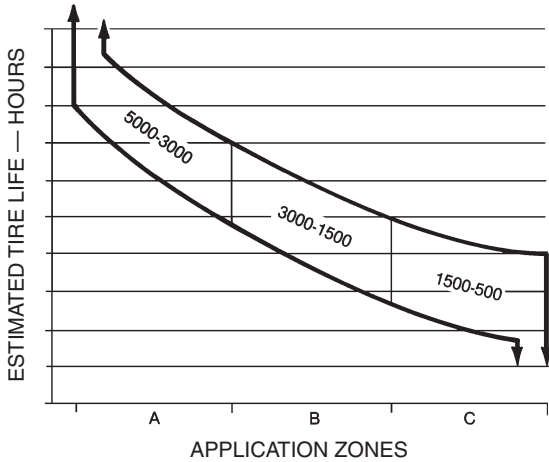

**CONSTRUCTION AND MINING TRUCKS**

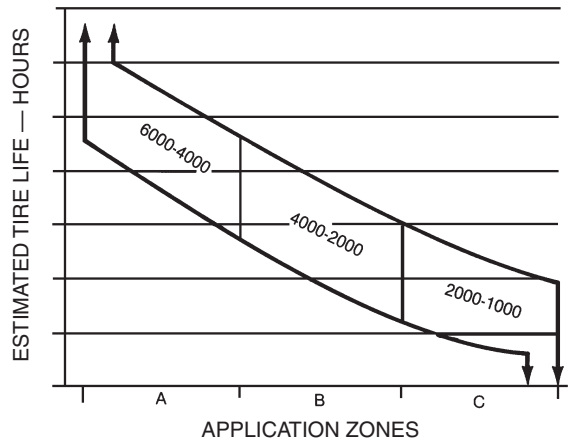

**Key:**

- Zone A — Almost all tires actually wear through the tread due to abrasion.
- Zone B — Some tires wear out normally while others fail prematurely due to rock cuts, impacts and non-repairable punctures.
- Zone C — Few, if any, tires wear through the tread because of non-repairable damages, usually from rock cuts, impacts or continuous overloading.

**UNDERGROUND TRUCKS**

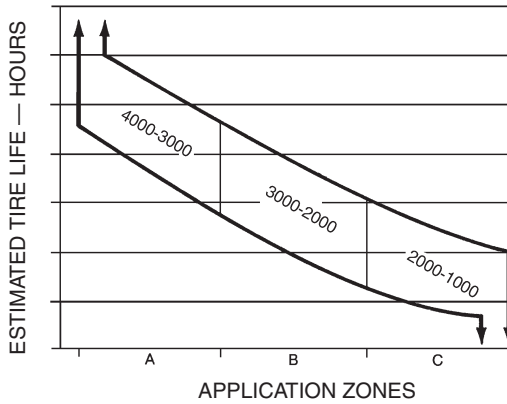

**TRACTORS/WAGONS**

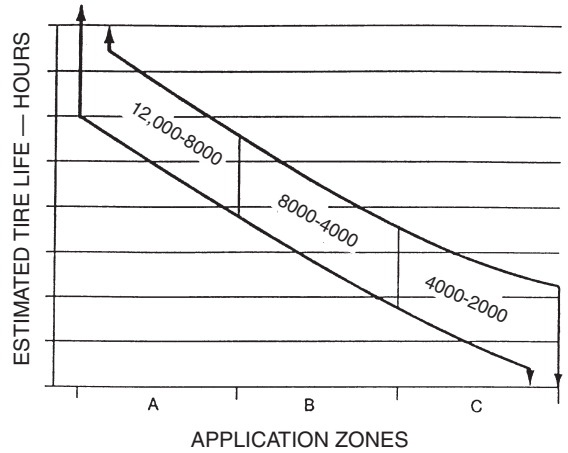

**ARTICULATED TRUCKS**

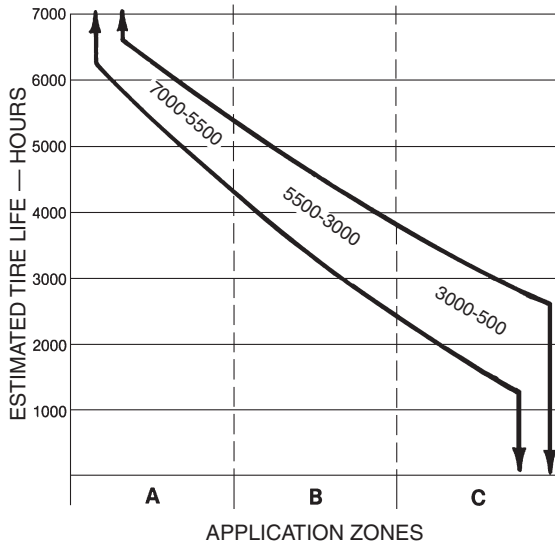

**WHEEL TRACTORS  
WHEEL LOADERS**

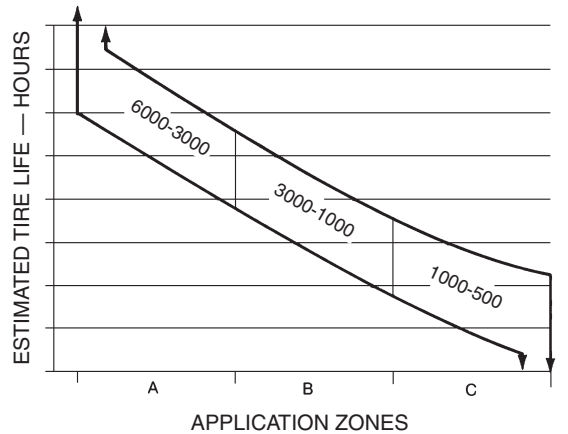

**Key:**

- Zone A — Almost all tires actually wear through the tread due to abrasion.
- Zone B — Some tires wear out normally, others fail prematurely due to rock cuts, impacts, and non-repairable punctures.
- Zone C — Few, if any, tires wear through the tread because of non-repairable damages, usually from rock cuts, impacts, or continuous overloading.

Application Tire Life	Tires Cost Per Hour — Basic Factors		
	Zone A 8000-5000	Zone B 5000-2500	Zone C 2500-500
Model 990 II 992G 994D	\$20-\$40	\$30-\$80	\$60-\$400

**GOODYEAR LIFE ESTIMATING SYSTEM**

As an additional assist in estimating *hauling unit* tire life, Goodyear Tire and Rubber Co. has furnished the following information which is included here with their permission. READ THE PREAMBLE CAREFULLY.

“... at present, there is no completely accurate, fool-proof method of forecasting tire life. Tire engineers have many theoretical methods ... but these generally are so involved and time consuming that they are impractical for field use.

“However, the tire industry has made many surveys of tire performance and arrived at a system which can give rough *estimates* of tire life. Studies done by the major tire companies and by at least two major equipment manufacturers are in close agreement.

“The table [which follows] shows how to apply this system ...”

**ESTIMATED TIRE SERVICE LIFE OF HAULING UNITS (Trucks and Scrapers)**

No.	Condition	Factor
<b>I</b>	<b>Maintenance</b>	
	Excellent	1.090
	Average	0.981
	Poor	0.763
<b>II</b>	<b>Speeds (Maximum)</b>	
	16 km/h ~ <b>10 mph</b>	1.090
	32 km/h ~ <b>20 mph</b>	0.872
	48 km/h ~ <b>30 mph</b>	0.763
<b>III</b>	<b>Surface Conditions</b>	
	Soft Earth — No Rock	1.090
	Soft Earth — Some Rock	0.981
	Well Maintained — Gravel Road	0.981
	Poorly Maintained — Gravel Road	0.763
	Blasted — Sharp Rock	0.654
<b>IV</b>	<b>Wheel Positions</b>	
	Trailing	1.090
	Front	0.981
	Driver (Rear Dump)	0.872
	(Bottom Dump)	0.763
	(Self Propelled Scraper)	0.654

No.	Condition	Factor
<b>V</b>	<b>Loads</b> (See No. VIII note)	
	T&RA/ETRTO* Recommended Loading	1.090
	20% Overload	0.872
	40% Overload	0.545
<b>VI</b>	<b>Curves</b>	
	None	1.090
	Medium	0.981
	Severe	0.872
<b>VII</b>	<b>Grades</b> (Drive Tires Only)	
	Level	1.090
	5% Max.	0.981
	15% Max.	0.763
<b>VIII</b>	<b>Other Miscellaneous Combinations</b> (See note below)	
	None	1.090
	Medium	0.981
	Severe	0.872
	<b>Condition VIII</b> is to be used when overloading is present in combination with one or more of the primary conditions of maintenance, speeds, surface conditions and curves. The combination of severe levels in these conditions, together with an overload, will create a new and more serious condition which will contribute to early tire failure to a larger extent than will the individual factors of each condition.	

\*Tire and Rim Association/European Tire and Rim Technical Organization.

Type of Tire	Base Average Life		
	Hours	km	Miles
E-3 Std. Bias Tread	2510	40 400	<b>25,100</b>
E-4 Bias Xtra Tread	3510	56 500	<b>35,100</b>
E-4 Radial Xtra Tread	4200	67 600	<b>42,000</b>

Using Base Hours (or Miles), multiply by the appropriate factor for *each* condition to obtain approximate estimated hours (or miles) as the final product.

*Example:* An off-highway truck equipped with E-4 drive tires running on a well maintained haul road having easy curves and minimum grades and receiving “average” tire maintenance attention but being 20% overloaded:

Condition: I II III IV V VI VII VIII  
 Factor: 0.981 × 0.872 × 0.981 × 0.872 × 0.872 × 0.981 × 0.981 × 0.981  
 × 3510 base hours = 2114 hours (say 2100 hours)

As can be seen, this system requires the careful application of strictly subjective judgments, and can be expected to result in conservative estimates. Keep in mind, however, **that the system is offered only as an aid in estimating and not as a rigid set of rules.**

On the other hand, if tire life on a given job is considered less than satisfactory, an analysis of these factors may point to conditions which can be improved to the betterment of tire life.

Replacement tire prices should always be obtained from local tire company sources.

Since tires are considered a wear item in this method of estimating owning and operating costs, total tire replacement cost is deducted from machine delivered price to arrive at a net figure for depreciation purposes. Outlay for tires is then included as an item in operating costs:

$$\text{Hourly Tire Cost} = \frac{\text{Replacement Cost of Tires}}{\text{Estimating Tire Life in Hours}}$$

Recapping can sometimes lower hourly tire cost. Considerations are availability of molds, local recapping costs, and experience with recap life.

**10b UNDERCARRIAGE**

(Line Item 10b)

Undercarriage expense can be a major portion of the operating costs for track-type machines, and these costs can vary *independently* of basic machine costs. That is, the undercarriage can be employed in an extremely abrasive, high-wear environment while the basic machine may be in an essentially easy application, and vice-versa. For that reason, it is recommended that the hourly cost of undercarriage be calculated separately as a wear item rather than being included in the repair costs for the basic machine.

Three primary conditions affect probable life-expectancy of track-type undercarriage:

- 1. Impact.** The most measurable effect of impact is structural — that is bending, chipping, cracking, spalling, roll-over, etc., and problems with hardware and pin and bushing retention.

*Impact ratings:*

*High* — Non-penetrable hard surfaces with 150 mm (6") or higher bumps.

*Moderate* — Partially penetrable surfaces and bumps of 75-150 mm (3-6") height.

*Low* — Completely penetrable surfaces (which provide full shoe plate support) with few bumps.

- 2. Abrasiveness.** The tendency of the underfoot materials to grind away the wear surfaces of track components.

*Abrasiveness ratings:*

*High* — Saturated wet soils containing a high proportion of hard, angular or sharp sand or rock particles.

*Moderate* — Slightly or intermittently damp soils containing a low proportion of hard, angular or sharp particles.

*Low* — Dry soils or rock containing a low proportion of hard, angular or sharp sand or rock chip particles.

Impact and abrasiveness in combination can accelerate wear rates beyond their individual effects when considered alone, thus further reducing component life. This should be taken into account in determining impact and abrasiveness ratings or, if preferred, the combination can be included in selecting the "Z" factor.

- 3. "Z" factor.** Represents the combined effect on component life of the many intangible environmental, operational and maintenance considerations on a given job.

*Environment and Terrain.* Earth which may not be abrasive itself can pack in sprocket teeth, causing mis-match and high stress as the teeth engage the bushings. Corrosive chemicals in the materials being moved or in the natural soil can affect wear rates, while moisture and temperature can exaggerate the effect. Temperature alone can play its own role — hot slag and hard-frozen soils being but the extremes. Constant sidehill work can increase wear on the sides of components.

*Operation.* Some operator practices tend to increase track wear and cost if not controlled on the job. Such practices include high-speed operation, particularly in reverse; tight turns or constant corrections in direction; and stalling the tractor under load forcing the tracks to slip.

*Maintenance.* Good maintenance — proper track tension, daily cleaning when working in sticky materials, etc. — combined with periodic wear measurement and timely attention to recommended services (CTS) can extend component life and lower costs by minimizing the effects of these and other adverse conditions.

While impact and abrasion should not be too difficult to judge, selection of the proper “Z” factor will require careful analysis of job conditions such as weather, tendency for soil packing, side-hill loading, corrosive environment, etc.; operational factors such as high-speed reverse, amount of travel, tight turns, track slippage under overload, etc.; and maintenance considerations such as proper tensioning, use of Custom Track Service, etc.

Selection of the “Z” multiplier is strictly a matter of judgement and common sense, but its effect on cost can be the difference between profit on a controlled job and heavy loss where control is allowed to slip. To assist in arriving at an appropriate value for the “Z” factor, consider that proper maintenance — or the lack thereof — will represent about 50% of its effect, environment and terrain 30%, and operator practices 20%. For large excavators the amount of travel is the critical part of the “Z” factor. A good operator working under good field conditions can be counterbalanced by poor maintenance practices to yield a fairly high “Z” factor. On the other hand, close attention to maintenance, tension and alignment can more than offset a bad underfoot condition resulting in severe sprocket packing, and lead to selection of a moderate to low “Z” factor. Obviously, flexibility in selection of a “Z” factor has been built into the system, and use of this flexibility is encouraged. Further, a considerable measure of control can be maintained over the “Z” factor, and any reduction of its effects is money in the bank. Your Cat dealer CTS man can be invaluable in this endeavor as well as helping you establish a comprehensive undercarriage cost control program.

**Estimating Undercarriage Cost**

The guide below gives a basic factor for the various track-type machines and a series of conditions multipliers to modify the basic cost according to the anticipated impact, abrasive and miscellaneous (“Z”) conditions under which the unit will be operating.

- Step 1. Select machine and its corresponding basic factor.
- Step 2. Determine range for impact, abrasiveness and “Z” conditions.
- Step 3. Add selected conditions multipliers and apply sum to basic factor.

The result will be the estimated hourly cost for undercarriage in that application.

Undercarriage Basic Factors			
Model	Basic Factor		
5230B	28.2		
D11T	26.1		
5130B	20.4		
D10T	16.2		
5110B	13.6		
D9T	10.9		
D8T	9.6		
973D, 587T, 589, D7R Series 2 LGP, D7E LGP	11.2		
D7R Series 2, 963D, 583T, D6T LGP, D7R XR Series 2, D7E	9.1		
385C, 5090B	7.2		
D6T, 953D, 572R, 527	7.0		
365C Tier 2	6.8		
345D	5.9		
D5N LGP, D6K, D6N XL, 517	5.6		
336D	5.0		
D3K (All), D4K (All), D5K (All), 939C, PL61	4.1		
329D	3.9		
314D, 315D, 319D, 323D	3.4		
320D	2.9		
307D, 308D, 311D, 312D	2.4		
Conditions Multipliers			
	Impact	Abrasiveness	“Z”
High	0.3	0.4	1.0
Moderate	0.2	0.2	0.5
Low	0.1	0.1	0.2

*Example:* D10T in high impact, non-abrasive material with a moderate “Z” factor.

$$\begin{aligned}
 \text{D10T Basic Factor} &= 16.2 \\
 \text{Multipliers:} \quad & \text{I} = 0.3 \\
 & \text{A} = 0.1 \\
 & \text{Z} = 0.5
 \end{aligned}$$

$$\text{U.C. cost} = 16.2 (0.3 + 0.1 + 0.5) = \mathbf{\$14.58/hour}$$

- NOTE:** 1. Conditions Multipliers may be selected in any combination. Thus, a multiplier of 0.4 (all low-range multipliers) represents the best of the best, while 1.7 (all high range multipliers) would be the worst of the worst conditions.
2. The hourly undercarriage cost estimate resulting from this method will be made up of *approximately* 70% parts cost and 30% labor charges. The cost of undercarriage components is based on published U.S. Consumers List Prices and may be adjusted as needed for import duties, exchange rates, etc. outside the United States. Labor has been figured at \$60.00 (U.S.) per shop hour.
  3. For further information and guidance, refer to the current issue of the Caterpillar Custom Track Service Handbook.
  4. This formula for estimating undercarriage cost should not be used for tractors working in stockpile coal handling applications. Undercarriage costs are nominal in stockpile coal handling, and using this formula will result in estimating cost substantially above actual costs.

11

## REPAIR COSTS

*(Line Item 11)*

Repair cost per hour should be developed by the Cat dealer, with customer input for the specific machine application and requirements.

As with PM cost per hour, repair costs are significantly affected by the specific application and situation. Several important variables must be provided by the customer and the local Cat dealer. This will enable a calculated cost per hour that is specific to the machine conditions and customer needs.

Machine applications, operating conditions, ownership periods, component life, and maintenance attention determine repair costs. In any specific application, actual cost experience on similar machines and applications provides the best basis for establishing the hourly repair cost.

Repairs and component lives are normally the largest single item in operating costs and include all parts and direct labor (except operator's wages) chargeable to the machine. Shop overhead can be absorbed in general overhead or charged to machines as a percent of direct labor cost, whichever is the owner's normal practice.

Hourly repair costs for a single machine normally follow an upward staircase pattern since major outlays for repairs usually come in spurts. However, when broad averages are considered, the staircase becomes a smooth, upward curve. Since this hourly repair cost curve starts low and gradually rises over time, hourly operating costs must be adjusted upward as the unit ages. Alternatively an average repair cost can be used which provides a straight line graph. Most owners prefer the average method, and it is the one suggested here.

Since repair costs are low initially and rise gradually, averaging them produces extra funds at first which are reserved to cover future higher costs.

**Your Cat dealer has the ability to make more accurate repair cost estimates and we suggest you use their experience and expertise if you need help in estimating operating costs.**

As stated, repair costs are affected by application, operating conditions, ownership period, maintenance, and age of the equipment. The most significant effects on cost will be those factors affecting major component life. A second significant factor is whether the repair is performed before or after catastrophic failure. Repair before a major component fails can be one-third of an after failure repair with only a moderate sacrifice in life (see graphs). Oil analysis and other diagnostic tools, maintenance inspections and indicators, and operator notes are vital to determine the optimum repair point and thereby achieving lower hourly repair costs. Maintenance practices are significant because they affect component longevity and the percentage of scheduled, before failure repairs.

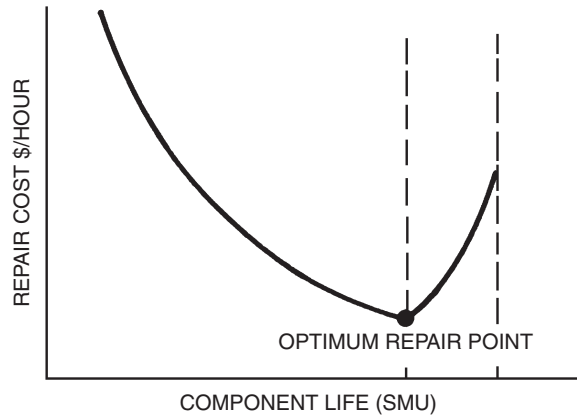
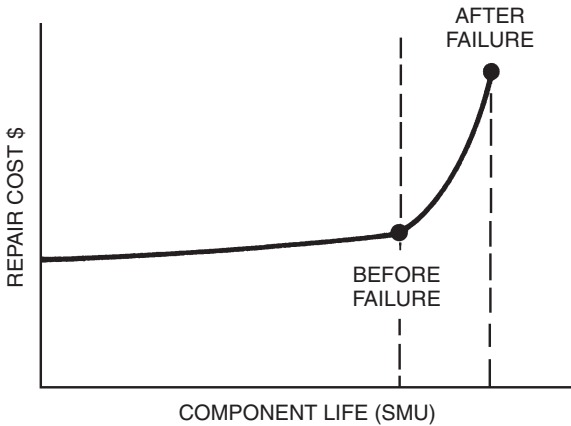



## Owning & Operating Costs

- ⑫ Special Wear Items
  - ⑮ Operator's Hourly Wage
- Owning & Operating Examples
- Track-Type Tractor

12

### SPECIAL WEAR ITEMS

(Line Item 12 and Subsection 12A)

All costs for high-wear items such as cutting edges, ripper tips, bucket teeth, body liners, router bits, etc., and welding costs on booms and sticks should be included here. These costs will vary widely depending on applications, materials and operating techniques. Consult your Cat dealer Parts Department for estimated life under your job conditions.

15

### OPERATOR'S HOURLY WAGE

(Line Item 15)

This item should be based on local wage scales and should include the hourly cost of fringe benefits.

## EXAMPLES OF FIGURING OWNING AND OPERATING COSTS

(The following two examples are for illustrative purposes only. The intent is to show how the worksheets could be filled out. The PM and Repair costs should be developed by your local Cat dealer.)

### Example I: ESTIMATING HOURLY OWNING AND OPERATING COSTS OF A TRACK-TYPE TRACTOR

Assume a power shift track-type tractor with straight bulldozer, hydraulic control, tilt cylinder and three-shank ripper, is purchased by a contractor for \$135,000, delivered price at job site.

Application will be production dozing of bank gravel. Minimal ripping will be required to loosen material.

In the following calculations, refer as necessary to the source material already reviewed.

#### OWNING COSTS —

##### To Determine Residual Value at Replacement

Enter delivered price, \$135,000, in space (A). (See example form at end of this discussion.) Since the machine being considered is a track-type tractor, no tires are involved. This particular owner's experience is that at trade-in time, the tractor will be worth approximately 35% of its original value. This \$47,250 trade-in value is entered in space (B) leaving a net of \$87,750 to be recovered through work.

Enter the net value to be recovered through work in space (C).

Indicated ownership period is 7 years with annual usage of 1200 hours per year or 8400 hours of total ownership usage.

Divide the Net Value from space (C), \$87,750, by Ownership Usage, 8400 hours, and enter result \$10.45 in space (D).

#### Interest, Insurance, Taxes

In this example, local rates are assumed as follows:

Interest	16%
Insurance	1%
Taxes	1%
	18%

Using the following formula:

$N = 7:$

$$\left[ \frac{135,000 (7 + 1) + 47,250 (7 - 1)}{2 \times 7} \right] \times 0.16 = 12.99$$

Enter \$12.99 in space (E).

Insurance and property taxes can also be calculated using the same formula as shown for the interest cost, and entering them on lines 5 and 6.

Items 3b, 4, 5 and 6 can now be added and the result, \$25.06 entered in space (H) Total Hourly Owning Costs.

#### OPERATING COSTS —

##### Fuel

See fuel consumption tables. The intended application, production dozing, indicates a medium load factor. Assume that the estimated fuel consumption from the table is 17 liter/hr (4.5 U.S. gal/hr.). Cost of fuel in this locality is \$0.34/liter (\$1.25/U.S. gal.).

Consumption	Unit Cost	Total
17 liter/hr	× \$0.34 liter	= \$5.78
4.5 gal/hr	× \$1.25 gal.	= \$5.63

Enter this figure in space (I).

**Planned Maintenance (PM) Cost per Hour**

Use PM cost per hour estimate developed by your local Cat dealer. (For this example assume cost per hour is \$2.30) Enter this figure in space (J) on line 9.

**Tires**

Since this example considers a track-type tractor, space (K) is left blank.

**Undercarriage**

Our estimating reference gives an undercarriage cost Basic Factor of 6.6 for this tractor. It is anticipated that with some ripping on the job, impact loading of track components will be medium, indicating an “I” multiplier of 0.2. The gravel-sand mix in the bank, being dry, should be only moderately abrasive for an “A” multiplier of 0.2. In analyzing the miscellaneous conditions: there is enough clay in the bank to produce some packing of the sprockets; the operator is careful, but is forced into some tight turns because of space limitations; there is good drainage in the pit; track tension is checked weekly; and all track-type equipment on the job is enrolled in the Custom Track Service program. Accordingly, the “Z” multiplier is judged to be somewhat greater than low level — 0.3 in this case.

It should be noted that in applying particularly the “Z” factor, rather wide flexibility is provided and was used in the above example. Such flexibility is intended and its use encouraged.

Then:

$$\text{Cost per hour} = \text{Basic Factor} \times (I + A + Z)$$

$$\text{Basic Factor} = 6.6$$

$$\text{Conditions Multipliers: } I = 0.2$$

$$A = 0.2$$

$$Z = 0.3$$

$$\text{Cost per hour } 6.6 (0.2 + 0.2 + 0.3) = \$4.62 \text{ which is entered in space (L).}$$

**Repair Cost per Hour**

Use the Repair cost per hour estimate developed by your local Cat dealer. (For this example assume cost per hour is \$6.12) Enter this figure in space (M) on line 11.

**Special Items**

Assuming the tractor is equipped with a three-shank ripper and an “S” dozer, allowance must be made for ripper tips, shank protectors, and dozer cutting edges.

Assume your knowledge of the operation indicates the ripper will be used only about 20% of total tractor operating time. Estimated tip life while in use is 30 hours. Therefore, tips will be replaced:

$$\frac{30 \text{ Hours}}{0.20} = \text{each } 150 \text{ hours of tractor operation}$$

Shank protector life is estimated at three times tip life or 450 hours of tractor operation.

Cutting edge life is estimated to be 500 hours.

Using local prices for these items, hourly costs are estimated as follows:

$$\text{Tips: } \frac{3 @ \$35.00 \text{ ea.}}{150 \text{ hr.}} = \$0.70 \text{ per hour}$$

$$\text{Shank Protectors: } \frac{3 @ \$55.00 \text{ ea.}}{450 \text{ hr.}} = \$0.37 \text{ per hour}$$

$$\text{Cutting Edges: } \frac{\$125 \text{ per set}}{500 \text{ hr.}} = \$0.25 \text{ per hour}$$

The total of these, \$1.32; is entered in space (N).

Items 8, 9, 10b, 11 and 12 can now be added and the result, \$19.99, is entered in space (O), Total Hourly Operating Costs.

**Operator’s Hourly Wage**

Assume this is \$25.00 including fringe benefits. This figure is entered in space (P).

Total Owning Costs, Total Operating Costs and Operator’s Hourly Wage are now added together and the result, \$67.01, is entered in space (Q). The itemized estimate of Hourly Owning and Operating Costs is now complete.

**Example II: ESTIMATING HOURLY OWNING AND OPERATING COSTS OF A WHEELED VEHICLE**

With only a few simple changes, owning and operating costs for a wheeled vehicle are calculated using the same format as that used for the Track-Type Tractor. Only the differences will be explained as we look at example calculations for a wheel loader.

**OWNING COSTS —****To Determine Residual Value at Replacement**

Enter delivered price in space (A). The cost of tires is deducted since they will be treated as a wear item. For purposes of illustration, the Wheel Loader is estimated to have a potential 48% trade-in value (B) at the end of the 5 year/7500 hour ownership usage, leaving a net value to be recovered through work of \$34,320 (C).

**Interest, Insurance, Taxes**

Refer to the formulas using the same rates as before and 1500 operating hours per year. The result \$4.22 is applied to the interest cost (E).

Insurance and property taxes can also be calculated using the same formula as shown for the interest cost.

The sum of lines 3b, 4, 5 and 6 gives the total hourly owning cost, line 7.

**OPERATING COSTS —****Fuel**

See the fuel consumption tables and apply the actual cost of purchasing fuel in the project area (I).

**Planned Maintenance (PM) Cost per Hour**

Use PM cost per hour estimate developed by your local Cat dealer. (For this example assume cost per hour is \$2.10.) Enter this figure in space (J) on line 9.

**Tires**

Use the tire replacement cost and the best estimate of tire life based on experience and anticipated job conditions.

**Repair Cost per Hour**

Use the Repair cost per hour estimate developed by your local Cat dealer. (For this example assume cost per hour is \$3.39.) Enter this figure in space (M) on line 11.

**Special Items**

Ground engaging tools, welding, etc. are covered here. Use current costs for cutting edges and similar items. Use your best estimate of the hours of life which can be expected from them based on previous experience in like materials. Enter the total on line 12.

The total of lines 8 through 13 represents hourly operating costs.

**Operator's Hourly Wage**

To give a true picture of operator cost, include fringe benefits as well as direct hourly wages (line 15).

**TOTAL O&O**

The total of lines 7, 13 and 15 is the total hourly owning and operating cost of the machine. Keep in mind that this is an estimate and can change radically from project to project. For the greatest accuracy, the hourly cost reflected in actual on-the-job cost records should be used.

**HOURLY OWNING AND OPERATING COST ESTIMATE**

DATE \_\_\_\_\_

	Estimate #1	Estimate #2
A—Machine Designation .....	Track-type Tractor	Wheel Loader
B—Estimated Ownership Period (Years) .....	7	5
C—Estimated Usage (Hours/Year) .....	1200	1500
D—Ownership Usage (Total Hours)(B × C) .....	8400	7500

**OWNING COSTS**

1. a. Delivered Price (P), to the Customer (including attachments) . .	(1) 135,000 (A)	(2) 70,000
b. Less Tire Replacement Cost if desired .....	N/A	4000
c. Delivered Price Less Tires .....	135,000	66,000
2. Less Residual Value at Replacement (S) .....	(35 %) 47,250 (B)	(48 %) 31,680
(See subsection 2A on back)		
3. a. Net Value to be recovered through work .....	87,750 (C)	34,320
(line 1c less line 2)		
b. Cost Per Hour:		
Net Value (1) 87,750 (2) 34,320 .....	10.45 (D)	4.58
Total Hours 8400 7500		
4. Interest Costs $\frac{P(N + 1) + S(N - 1)}{2N} \times \text{Simple Int. \% Rate}$		
N = No. Yrs. Hours/Year =		
(1) $\frac{[135,000 (7 + 1)] + [47,250 (7 - 1)]}{2 \times 7} \times 0.16$		
(2) $\frac{[66,000 (5 + 1)] + [31,680 (5 - 1)]}{2 \times 5} \times 0.16$		
1200 Hours/Yr. = 1500 Hours/Yr.	12.99 (E)	5.58
5. Insurance $\frac{P(N + 1) + S(N - 1)}{2N} \times \text{Insurance \% Rate}$		
N = No. Yrs. Hours/Year =		
(1) $\frac{[135,000 (7 + 1)] + [47,250 (7 - 1)]}{2 \times 7} \times 0.01$		
(2) $\frac{[66,000 (5 + 1)] + [31,680 (5 - 1)]}{2 \times 5} \times 0.01$		
1200 Hours/Yr. = 1500 Hours/Yr.	0.81 (F)	0.35

(Optional method when Insurance cost per year is known)

Ins. \$ \_\_\_\_\_ Per Yr. ÷ \_\_\_\_\_ Hours/Yr. =

*Estimating form continues next page*

Estimate #1                      Estimate #2

6. Property Tax  $\frac{P(N + 1) + S(N - 1)}{2N} \times \text{Tax Rate \%}$   
 N = No. Yrs.  $\frac{\hspace{10em}}{\text{Hours/Year}} =$

(1)  $\frac{[135,000 (7 + 1)] + [47,250 (7 - 1)]}{2 \times 7} \times 0.01$                       (2)  $\frac{[66,000 (5 + 1)] + [31,680 (5 - 1)]}{2 \times 5} \times 0.01$

$\frac{\hspace{10em}}{1200 \text{ Hours/Yr.}} =$                        $\frac{\hspace{10em}}{1500 \text{ Hours/Yr.}} =$                       0.81 (G)                      0.35

(Optional method when Property Tax cost per year is known)

Property Tax \$                      Per Yr.  $\div$                       Hours/Yr. =

7. TOTAL HOURLY OWNING COST  
 (add lines 3b, 4, 5 and 6) ..... 25.06 (H)                      10.86

**OPERATING COSTS**

8. Fuel:                      Unit Price  $\times$  Consumption

(1)  $\frac{1.25}{1.25} \times \frac{4.50}{2} =$                       5.63 (I)                      2.50

(2)  $\frac{\hspace{10em}}{\hspace{10em}} \times \frac{\hspace{10em}}{\hspace{10em}} =$

9. Planned Maintenance (PM)-Lube Oils, Filters, Grease, Labor:  
 (contact your local Cat dealer) ..... 2.30 (J)                      2.10

10. a. Tires: Replacement Cost  $\div$  Life in Hours

$\frac{\text{Cost}}{\text{Life}}$  (1)  $\frac{N/A}{3500}$  (2)  $\frac{4000}{3500}$  ..... (K)                      1.14

b. Undercarriage  
 (Impact + Abrasiveness + Z Factor)  $\times$  Basic Factor

(1)  $(0.2 + 0.2 + 0.3) = 0.7 \times 6.6 =$                       4.62 (L)                      \_\_\_\_\_

(2)  $(\hspace{10em} + \hspace{10em} + \hspace{10em}) = \frac{\hspace{10em}}{\text{(Total)}} \times \frac{\hspace{10em}}{\text{(Factor)}} =$

11. Repair Cost (Per Hour)  
 (contact your local Cat dealer) ..... 6.12 (M)                      3.39

12. Special Wear Items: Cost  $\div$  Life ..... 1.32 (N)                      0.60  
 (See subsection 12A on back)

13. TOTAL OPERATING COSTS  
 (add lines 8, 9, 10a (or 10b), 11 and 12) ..... 19.99 (O)                      9.73

14. MACHINE OWNING PLUS OPERATING  
 (add lines 7 and 13) ..... 45.05                      20.59

15. OPERATOR'S HOURLY WAGE (include fringes) ..... 25.00 (P)                      25.00

16. TOTAL OWNING AND OPERATING COST ..... 70.05(Q)                      45.59

**SUBSECTION 2A: Residual Value at Replacement**

Gross Selling Price	(est. #1) (___%) _____	(est. #2) (___%) _____
Less: a. Commission	_____	_____
b. Make-ready costs	_____	_____
c. Inflation during ownership period*	_____	_____
Net Residual Value	<u>47,250</u> (35%)	<u>31,680</u> (48%) of original delivered price
(Enter on line 2)		

\*When used equipment auction prices are used to estimate residual value, the effect of inflation during the ownership period should be removed to show in constant value what part of the asset must be recovered through work.

**SUBSECTION 12A: Special Items  
 (cutting edges, ground engaging tools, bucket teeth, etc.)**

(1)	Cost	Life	Cost/Hour	(2)
1.	<u>105</u> ÷	<u>150</u> =	<u>0.70</u>	1. <u>120</u> ÷ <u>200</u> = <u>0.60</u>
2.	<u>165</u> ÷	<u>450</u> =	<u>0.37</u>	2. _____ ÷ _____ = _____
3.	<u>125</u> ÷	<u>500</u> =	<u>0.25</u>	3. _____ ÷ _____ = _____
4.	_____ ÷	_____ =	_____	4. _____ ÷ _____ = _____
5.	_____ ÷	_____ =	_____	5. _____ ÷ _____ = _____
6.	_____ ÷	_____ =	_____	6. _____ ÷ _____ = _____
	Total	(1) <u>1.32</u>	(2) <u>0.60</u>	

(Enter total on line 12)



## CONTENTS

Selection, Application, Maintenance	.21-1
Tire Construction	.21-2
Bias Ply	.21-2
Radial Ply	.21-3
Tire Types	.21-3
Tire Size Nomenclature	.21-3
Code Identification for	
Off-Highway Tires	.21-4
Manufacturers' Designations —	
Firestone, Goodyear, Dunlop,	
Bridgestone, Michelin	.21-5
Triangle, Eurotire, Yokohama, Belshina	.21-7
Firestone, Goodyear, Dunlop,	
Bridgestone, Michelin	.21-8
Triangle, Eurotire, Yokohama	.21-10
Nokian, Belshina, Pirelli	.21-10
Radial Tire Identification:	
Michelin	.21-11
Goodyear	.21-12
Bridgestone	.21-13
Ton-Kilometer Per Hour Rating System	.21-14
Tire Drive-Away Recommendations	.21-15
TKPH Ratings	
— Goodyear Radial Ply	.21-16
— Bridgestone Radial Ply	.21-19
— Michelin Radial Ply	.21-22
Tire and Rim Association Ratings	.21-26
Tire Selection	.21-26
Guide	.21-28
Standard Cold Inflation Pressures	.21-29
Liquid Ballasting Table	.21-43

## SELECTION, APPLICATION, MAINTENANCE

Proper tire selection, application and maintenance continue to be the most important factors in earthmoving economics. Wheel tractors, loaders, scrapers, trucks, motor graders, etc. are earthmoving equipment whose productivity and payload unit cost may depend more on tire performance than any other factor.

Off-the-road tires must operate under a wide variety of conditions ranging from dry “potato dirt” through wet severe shot rock. Speed conditions vary from less than 1 mph average to 72 km/h (45 mph). Gradients may vary from 75% favorable to 30% adverse. Climatic conditions, operator skills, maintenance practices, etc. all may have a profound effect on tire life and unit costs.

Although one specific tire construction may be acceptable in a variety of applications, no one tire can meet all requirements on any one machine and perhaps not even one job. The many differences in tire requirements on earthmoving machines have resulted in a wide variety of tread and casing designs being made available. The optimum tire selection for a specific machine on a given job should be a joint decision between the user and tire supplier. Several tire manufacturers have technical and application representatives in the field for proper guidance in tire selection.

When job conditions change, it may be desirable to select a different tire configuration to meet the new requirements.



## TIRE CONSTRUCTION

The pneumatic tire is essentially a flexible pressure vessel utilizing structural members (nylon, steel cable, etc.) to contain the hoop tension resulting from the inflation pressure. Rubber is utilized as a protective coating and sealant over the structural members and makes up the tread pattern which provides the wearing medium at the ground interface. The following brief explanation of the various tire constructions will assist you in selecting tires for your specific application.

Two distinct tire constructions approved on all Cat machines are the BIAS PLY and RADIAL PLY tires. Radial tires are designated by an “R” while a “.” represents a Bias constructed tire. For example, a 45/65-45 tire would be of Bias construction and a 45/65R45 would be of Radial construction. The following is a brief explanation of the principal features of these two constructions.

### Bias Ply

1. *Beads* — The tire beads consist of steel wire-bundles (3 or 4 in larger tires) which are forced laterally by tire inflation pressure to wedge the tire firmly on the rim’s tapered bead seat. The nylon plies tie into the bead bundles. The forces inherent in the tire are transmitted from the rim through the bead bundles into the nylon.
2. *Body plies* — Layers of rubber-cushioned nylon cord comprise the tire casing. Alternating plies of cord cross the tread centerline at an angle (bias). The term “ply rating” is an index of tire strength and not the actual number of tire plies.

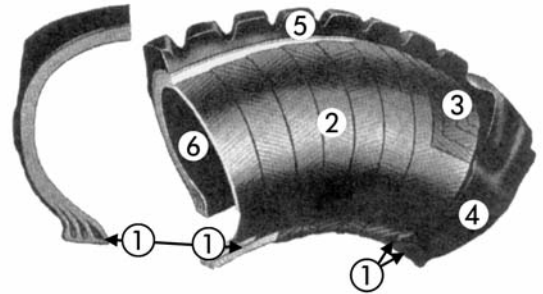

Bias Ply Construction

3. *Breakers or tread plies* — These, if used, are confined to the tire’s tread area and are intended to improve casing strength and provide additional protection to the body plies. Some “work” tires employ steel breakers or belts to further protect the casing.
4. *Sidewalls* — These are the protective rubber layers covering the body plies in the sidewall.
5. *Tread* — The wearing part of the tire that contacts the ground. It transmits the machine weight to the ground and provides traction and flotation.
6. *Inner liner* — This is the sealing medium that retains the air and, combined with the “O” ring seal and rim base, eliminates the need for inner tubes and flaps.
7. *Tubes and flaps (not shown)* — Required if the tire is not of tubeless construction with an inner liner.
8. *Undertread* — Protective rubber cushion lying between tread and body ply.

**Radial Ply**

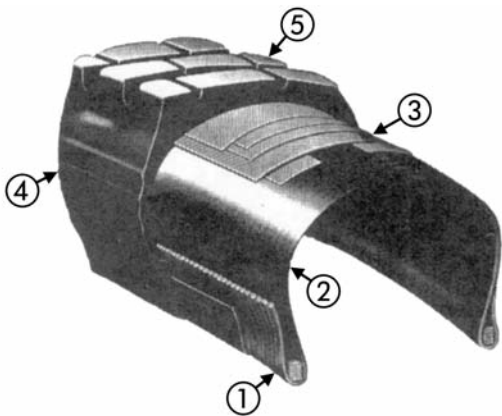

**Radial Ply Construction**

1. *Beads* — A single bead bundle of steel cables or steel strip (spiraled like a clock spring) comprise the bead at each rim interface.
2. *Radial casing* — This consists of a single layer or ply of steel cables laid archwise (on the radian) bead to bead.
3. *Belts* — Several layers or plies of steel cable form the belts which underlie the tread area around the tire circumference. The cable in each belt crosses the tread centerline at an angle with the angle being reversed from the preceding belt.
4. *Sidewalls*.
5. *Tread*.
6. *Undertread* — Protective rubber cushion lying between tread and steel belts.

**Bias and Radial Tire Advantages**

	Bias	Radial
Tread Life		X
Heat Resistance		X
Cut Resistance — Tread		X
Cut Resistance — Side Wall	X	X
Traction		X
Flotation		X
Stability	X	
Fuel Economy		X
Repairability		X

**TIRE TYPES**

Off-the-road tires are classified by application in one of the following three categories:

1. *Transport tire* — For earthmoving machines that transport material such as trucks and wheel tractors.
2. *Work tire* — Normally applied to slow moving earth-moving machines such as graders and loaders.
3. *Load and carry* — Wheel loaders engaged in transporting as well as digging.

**TIRE SIZE NOMENCLATURE**

Tire size nomenclature is derived from the approximate cross section width and rim diameter typically in the format of Tire Width, Aspect Ratio, and Rim Diameter (example: 45/65-45). Available tire types include:

1. A wide base tire has a section height to section width ratio in the range of 0.83. As an example, a 29.5-25 tire has an approximate cross section width of 749 mm (29.5") (first number) and a rim diameter of 635 mm (25") (second number).
2. A conventional tire has a section height to section width ratio in the range of 0.96. As an example, a 24.00R35 tire has an approximate cross section width of 610 mm (24") (first number) and a rim diameter of 889 mm (35") (second number).
3. A low profile tire has a section height to section width ratio in the range of 0.65. As an example, a 45/65-45 tire has an approximate cross section width of 1143 mm (45") (first number), a 65% aspect ratio designated as 65 (second number), and a rim diameter of 1143 mm (45") (third number).

If designated 45/65 R39, then the R denotes radial construction.

When comparing a wide base tire to a standard base tire, a larger first number on a wide base tire with the same rim diameter does not mean the wide base is larger in overall diameter. For example, the 18.00-25 conventional tire is larger in diameter than the 20.5-25 wide base tire. The 18.00-25 is comparable in overall diameter to the 23.5-25 wide base tire.

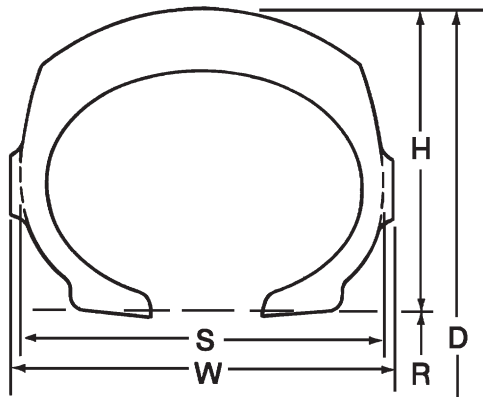

Tire cross-section

- D = Tire Overall Diameter
- R = Nominal Rim Diameter
- H = Tire Section Height
- S = Tire Section Width
- W = Tire Width (includes ornamental ribs)
- $\frac{H}{S}$  = Aspect Ratio

**CODE IDENTIFICATION FOR OFF-HIGHWAY TIRES**

The tire industry has adopted a code identification system to be used for off-the-road tires. This identification system will reduce the confusion caused by the trade names for each type of tire offered by each tire manufacturer. The industry code identification is divided into six main categories by types of service as follows:

- C** — Compactor Service
- E** — Earthmover Service
- G** — Grader Service
- L** — Loader and Dozer Service
- LS** — Log-Skidder Service
- F** — Industrial
- R** — Agricultural Tractor
- I** — Agricultural Implement

The sub-categories are designated by numerals, as follows:

Code Identification		% Tread Depth
<b>Compactor</b>		
C-1	Smooth	100
C-2	Grooved	100
<b>Earthmover</b>		
E-1	Rib	100
E-2	Traction	100
E-3	Rock	100
E-4	Rock Deep Tread	150
E-7	Flotation	80
<b>Grader</b>		
G-1	Rib	100
G-2	Traction	100
G-3	Rock	100
G-4	Rock Deep Tread	150
<b>Loader and Dozer</b>		
L-2	Traction	100
L-3	Rock	100
L-4	Rock Deep Tread	150
L-5	Rock Extra Deep Tread	250
L-3S	Smooth	100
L-4S	Smooth Deep Tread	150
L-5S	Smooth Extra Deep Tread	250
L-5/L-5S	Half Tread Extra Deep	250
<b>Log-Skidders</b>		
LS-1	Regular Tread	100
LS-2	Intermediate Tread	125
LS-3	Deep Tread	150
HF-4	Extra Deep Tread	250
<b>Industrial</b>		
F-3	Traction Tread	
<b>Agricultural Tractor</b>		
R-1	Regular Tread	
R-3	Shallow Tread	
R-4	Industrial Tractor	
<b>Agricultural Implement</b>		
I-3	Tractor Tread	

Tire and Rim Assoc. Code	Tread Type	FIRESTONE	GOODYEAR DUNLOP	BRIDGESTONE	MICHELIN
<b>Compactor</b>					
C-1	Smooth Compactor		SMC-1A	RR	COMPACTEUR
C-2	Grooved Compactor			AL2	
<b>Earthmover</b>					
E-1	Rib		HRR-1A XDR-1A		
E-2	Traction	Super Ground Grip	GP-2B GP-3D AT-2 AT-2A RL-2F SGL-2A	VKT VSB VHB VFT VHS VSW	XGC X-CRANE XMH (S) XSNPLUS 170E XS XR XTLA
E-3	Rock	Super Rock Grip E67	GP-2B GP-3D HRL-3A HRL-3B HRL-3C HRL-3F RL-3 RL-3+ RL-3A RL-3F RL-3J RM-3A RT-3A RT-3B WRL-3A	VLT VMT VJT VEL VRL VRD VRF WL RL	XK XR XMS XH XADN XAD65-1 SUPER E3 X-TRACTION RD S XTS XDM X-STRADDLE
E-4	Rock Deep Tread	Super Rock Grip Deep Tread	GP-4B GP-4B AT GP-4D GT-4B HRL-4A HRL-4B MRL-4B, F RL-4 RL-4A RL-4B RL-4F RL-4H RL-4HII RL-4J RL-4JII RL-4L RL-4M+ RM-4A+ RT-4A	VLTS VSNT VMTS VMTP VZTS VZTP VELSL VELS VRLS VRDP VRPS VRQP RLS ELS2	XDT XDR XRS XADT X SUPER TERRAIN AD XDM XHAUL XHAUL S XHD1 XKD1 X-QUARRY X-QUARRY S X-TRACTION RD
E-5	Rock Extra Deep Tread				
E-7	Flotation		EAW-7A SAW-7A SHY-7A SR-7A SRB-7A SRB-7A, 7B	VSJ SCP2	

**Tires** | Manufacturer's Designation

Tire and Rim Assoc. Code	Tread Type	FIRESTONE	GOODYEAR DUNLOP	BRIDGESTONE	MICHELIN
<b>Grader</b>					
<b>G-1</b> <b>G-2</b>	Rib Traction	Super Ground Grip Road Builder	RBG-1A GP-2B GP-3D AS-3A ASG-2A AT-2A RL-2+ RL-2F SG-2A SG-2B SGG-2A SGL D/L-2A	RG FG GL VKT VSW VUT	XTL X SNOPLUS XGLA2 XR
<b>G-3</b>	Rock		GP-2B GP-3D HRL D/L-3A RKG-3A RKG-3C RL-3J RT-3B	RL	XH XLD L3
<b>G-4</b>	Rock Deep Tread	Super Rock Grip Deep Tread Road Builder	GP-4B GP-4B AT GP-4D SGG-4B HRL D/L-5A		XLD D1 XLD SUPER L3
<b>G-5</b>	Rock Extra Deep Tread				XLD D2
<b>Soil Compactor</b>					
<b>R-1</b>	Regular Tread	Super All Traction II Super All Traction			
<b>R-3</b>	Shallow Tread	All Non-Skid Tractor	SFT105		

Tire and Rim Assoc. Code	Tread Type	TRIANGLE	EUROTIRE	YOKOHAMA	BELSHINA
<b>Compactor</b>					
C-1	Smooth Compactor				
C-2	Grooved Compactor				
<b>Earthmover</b>					
E-1	Rib				
E-2	Traction	TM518 TL508			
E-3	Rock	TB516		Y67 RB31	
E-4	Rock Deep Tread		Y11 U11 U12 U14		FT-116AM BEL-102 FT-117 FT-115
E-5	Rock Extra Deep Tread				
E-7	Flotation				
<b>Grader</b>					
G-1	Rib				
G-2	Traction	TL508			
G-3	Rock				
G-4	Rock Deep Tread				
G-5	Rock Extra Deep Tread				

Tire and Rim Assoc. Code	Tread Type	FIRESTONE	GOODYEAR DUNLOP	BRIDGESTONE	MICHELIN
<b>Log Skidder</b>					
LS-1 LS-2	Intermediate	Forestry Special CRC Forestry Special Severe Service		TGS	
LS-3 HF-4	Deep Extra Deep				
<b>Loader and Dozer</b>					
L-2	Traction	Super Ground Grip LD	GP-2B GP-3D AT-2 AT-2A RL-2F SGL D/L-2A SPT9 ET91 ET91-2	VUT VKT VSW GL FG	XLT XGL 2 XF X SNOPLUS M&S XMCA
L-3	Rock	Super Rock Grip LD	GP-2B GP-3D ELV-3A HRL D/L-3A HRL D/L-3B HRL D/L-3C HRL-3A RL-3 RL-3F RL-3J RT-3B	VLT VMT VJT VTS RL VL2	XH A XH A2 XLD L3 XKA XZSL
L-4	Rock Deep Tread	Super Rock Grip Deep Tread LD	AMS DMS D/L-4/15C AMS-4/5A GP-4B GP-4B AT GP-4C GP-4D HRL D/L-4/15C HRL D/L-4A HRL D/L-4G NRL D/L-4A NRL NDL D/L-4/15C RL-4K	VLTS VSNT VSNL RLS NL	XKD1 XLD D1 XLD SUPER L3

Tire and Rim Assoc. Code	Tread Type	FIRESTONE	GOODYEAR DUNLOP	BRIDGESTONE	MICHELIN
<b>Loader and Dozer (cont'd)</b>					
L-5	Rock Extra Deep Tread	Super Deep Tread LD	AMS D/L-5/8H AMS D/L-5/9A AMS DMS D/L-4/15C AMS-5/11F AMS-5/15C AMS-5/8F DRL D/L-5A HRL D/L-5A HRL D/L-5B NRL D/L-5A NRL NDL D/L-5/15C RL-5C,E,F RL-5K RL-5S RT-5C	VSDT VSDL DL	XLD D2 X MINE D2
L-3S	Smooth Tread	Plain Tread LD	SM-3A SMO D/L-3A		
L-4S	Smooth Deep Tread	Plain Tread LD	NSM D/L-4B SMO D/L-4A, B SMO-4B		
L-5S	Smooth Extra Deep Tread	Plain Tread LD Plain LD UMS	NSM D/L-5B SM-5A SMO D/L-5A, B SMO-5A, B, C	VSMS STMS	XSMD 2
L-5/L-5S	Half Smooth	Half Tread LD		DL2	
<b>Backhoe Loader</b>					
F-3	Industrial Multiple- Rib Tread	Industrial Special			
I-3	Traction Tread	Super Traction Loader			
R-4	Drive Wheel, Industrial Tractor Tread	All Traction Utility	SG Lug IT525 Industrial Sure Grip		XMCL



Tire and Rim Assoc. Code	Tread Type	TRIANGLE	EUROTIRE	YOKOHAMA
<b>Log Skidder</b>				
LS-1				
LS-2	Intermediate			
LS-3	Deep			
HF-4	Extra Deep			
<b>Loader and Dozer</b>				
L-2	Traction	TL508		
L-3	Rock	TB516 TL612	F-220	RB31
L-4	Rock Deep Tread			Y524
L-5	Rock Extra Deep Tread		Euro 50	
L-3S	Smooth Tread			
L-4S	Smooth Deep Tread			
L-5S	Smooth Extra Deep Tread			
L-5/L-5S	Half Smooth			

Tire and Rim Assoc. Code	Tread Type	NOKIAN	BELSHINA	PIRELLI
<b>Log Skidder</b>				
LS-1				
LS-2	Intermediate			
LS-3				
HF-4				
<b>Loader and Dozer</b>				
L-2	Traction	Loader Grip TL		
L-3	Rock			
L-4	Rock Deep Tread		FBEL-283	RM99
L-5	Rock Extra Deep Tread			
L-3S	Smooth Tread			
L-4S	Smooth Deep Tread			
L-5S	Smooth Extra Deep Tread			
L-5/L-5S	Half Smooth			

## RADIAL TIRE IDENTIFICATION

### Code Identification for Michelin Tires

All Michelin earthmover tires are radial construction, designated by the “X” marking. They contain a single steel radial ply with a series of steel belts placed around the tire’s circumference which reinforce and stabilize the tread.

Following are the tread designs currently available from Michelin with the different internal constructions depending on the application.

- Type A4** Particularly resistant to cuts, tread tearing and abrasion on very rough surfaces.
- Type A** Particularly resistant to cuts, tread tearing and abrasion at average speeds which are higher than those for A4 (above).
- Type B4** Compromise solution between abrasion resistance and average speed on rough surfaces (available in sizes 49 inch rim diameter and above).
- Type B** Higher resistance to internal heat generation on surfaces which are not particularly rough.
- Type C4** For running on long cycles at high speeds on well maintained roads.
- Type C** Very high resistance to high average speeds on long cycles run on well maintained roads.

The current combinations of tread patterns, construction, and tread depths offered, and primary TRA codes are:

Tread Design	Tread Compounds				Primary TRA Code(s)
	Type A4	Type A	Type B	Type C	
X MINE D2		X			L-5
XAD 65-1			X		E-3
XADN			X		E-3
XADT			X		E-4
XDC			X	X	E-3
XDM		X	X		E-3, E-4
XDR	X	X	X	X	E-4
XDT	X	X	X	X	E-4
XGLA2		X			G-2, L-2
XH		X			G-3, E-2, E-3
X-HAUL			X		E-4
XK		X	X		E-3
XKD1	X	X	X		E-4
XLD		X			G-3, L-3
XLD D1		X			L-4
XLD D2		X			L-5
XLISSE				X	C-1
XMH				X	E-2
XMS		X	X		E-3
X-QUARRY			X		E-4
XR			X	X	E-3, L-3
XRS			X		E-4
XSMD2+		X			L-5S
XSNPLUS		X			L-2, G-2
XTL		X			G-2, L-2
X-TRACTION					
RD (X)			X		E-4
XTS			X		E-3

Since Michelin radial tires contain a single steel casing ply, they utilize the industry method of designating radial tire strength in terms of “stars.” Their system consists of a one star, two star, and three star rating as an indication of the tire’s carrying capacity. The one star is the lightest construction, generally used on work and slow moving transport machines. Two star tires are used on most medium and high speed transport machines. Three star construction provides the greatest carrying capacity for a given size and is only available in small standard base tires.

This combination of tread designs and types of construction provides a range of radial tires which cover most earthmoving applications. We recommend that in applying steel radial tires to your machines you provide all site condition data to the tire manufacturer. Obtain their recommendations as to which tire will provide the most economical operation.

### Code Identification for Goodyear Radial Tires

All Goodyear steel radial earthmover tires have been designated *Unisteel* followed by a three or four digit alpha-numeric code that identifies the particular tread. For example, for a RL-2+, RL stands for Rock Lug and indicates that the upper sidewall has rock protection. The number in the code corresponds to the tire industry identification system (2-traction, 3-rock, etc). The fourth digit, if any, is used to designate tread design differences for the same basic tread type.

Following are the radial tread designs currently available from Goodyear with the compound and construction types depending on the application.

Compound Description	Compound Code	Construction Description	Construction Code
Heat Resistant	2	Standard	S
Standard Abrasion Resistant	4	Heavy Duty	H
Ultra Abrasion Resistant	6	Extra Heavy Duty	HW
		Steel Breakers	J
		Heavy Undertread	U
		Low Angle Belts	SL

Tread Design	Compound Code			Primary TRA Code(s)
	2S	4S	6S	
AT-2A	X	X	X	E-2, L-2, G-2
GP-2B	X	X	X	E-2, E-3, G-2, G-3, L-2, L-3
GP-3D	X	X	X	E-2, E-3, G-2, G-3, L-2, L-3
GP-4B AT	X	X	X	E-4, G-4, L-4
GP-4D	X	X	X	E-4, G-4, L-4
GT-4B	X	X	X	E-4
RL-2+	X	X	X	G-2
RL-2F	X	X	X	E-2, G-2, L-2
RL-3	X	X	X	E-3, L-3
RL-3+	X	X	X	E-3
RL-3A	X	X	X	E-3
RL-3F		X		E-3, L-3
RL-3J	X	X	X	E-3, G-3, L-3
RL-4	X	X	X	E-4
RL-4A	X	X	X	E-4
RL-4B	X	X	X	E-4
RL-4F	X	X	X	E-4
RL-4H	X	X	X	E-4
RL-4HII	X	X	X	E-4
RL-4J	X	X	X	E-4
RL-4JII	X	X	X	E-4
RL-4K		X	X	L-4
RL-4M+	X	X	X	E-4
RL-5K		X	X	L-5
RM-3A	X	X		E-3
RM-4A+	X	X	X	E-4
RT-3A	X	X		E-3
RT-3B			X	E-3, G-3, L-3
RT-4A	X	X	X	E-4

A star rating system instead of the ply rating system indicates the casing strength of radial tires. These symbols indicate the recommended inflation for a particular tire load. Following the star rating code is Goodyear's Custom Compound and Construction code. For a tire designated "2S" the 2 indicates a heat resistant compound and the S indicates standard construction. The higher the number the greater the abrasion and cut resistance with a corresponding lower TKPH/TMPH rating.

### Code Identification for Bridgestone Radial Tires

The Bridgestone steel radial earthmover has been designated as V-Steel. Following are the radial tread designs currently available from Bridgestone with the compound and construction types depending on the application.

#### Bridgestone Compound and Structure Codes

1A	Standard
2A	Cut-Resistant
2V	Special Cut Resistant (Steel Breaker)
2Z	Special Cut Resistant (Side Steel Breaker)
3A	Heat-Resistant
E	Earthmover
G	Grader
D	Loader and Dozer
S	Logging

The casing strength, i.e., load carrying capacity of tire is indicated by star rating system; 1-star, 2-star and 3-star. Bridgestone's Off-the-Road tires are designed and produced to meet the commonly accepted international standards, those set by the TRA (Tire and Rim Association) in the U.S.A., by the ETRTO (European Tire and Rim Technical Organization) in Europe and/or by the JATMA (Japan Automobile Tire Manufacturers' Association) in Japan. Where differences exist between the TRA, ETRTO and JATMA standards, Bridgestone selects the most appropriate.

Tread Design	Tread Name	Compound/ Structure Codes					TRA Code(s)
		1A	2A	2V	2Z	3A	
VEL	V-Steel E-Lug					X	E-3
VELS	V-Steel E-Lug S	X	X			X	E-4
VELSL	V-Steel E-Lug S (Long Haul)						E-4
VFT	V-Steel F-Traction	X				X	E-2
VHB	V-Steel H-Block						E-2
VHS	V-Steel H-Service						E-2
VJT	V-Steel J-Traction						E-3, L-3
VKT	V-Steel K-Traction	X	X				E-2, G-2, L-2
VLT	V-Steel L-Traction	X	X				E-3, L-3
VLTS	V-Steel L-Traction S			X			E-4, L-4
VMT	V-Steel M-Traction	X	X			X	E-3, L-3
VMTP	V-Steel M-Traction Premium	X	X				E-4
VMTS	V-Steel M-Traction S	X	X			X	E-4
VRD	V-Steel Rock Deep	X				X	E-3
VRDP	V-Steel Rock Deep Premium	X	X			X	E-4
VRF	V-Steel Rock Fast						E-3
VRL	V-Steel R-Lug	X	X			X	E-3
VRLS	V-Steel R-Lug S	X	X			X	E-4
VRPS	V-Steel Rock Premium Service						E-4
VRQP	V-Steel Rock Quarry Premium	X					E-4
VS	V-Steel S-Block			X		X	E-2
VSDL	V-Steel D-Lug			X			L-5
VSDT	V-Steel Super Deep Traction			X			L-5
VSJ	V-Steel Jamal						E-7
VSMS	V-Steel Smooth Tread-MS	X	X				L-5S
VSNL	V-Steel N-Lug			X			L-4
VSNT	V-Steel N-Traction			X			E-4, L-4
VSW	V-Steel Snow Wedge			X			E-2, G-2, L-2
VTS	V-Steel Traction- Stability			X			L-3
VUT	V-Steel U-Traction			X			G-2, L-2
VZTP	V-Steel Z-Traction Premium						E-4
VZTS	V-Steel Z-Traction S	X	X			X	E-4

## TON-KILOMETER PER HOUR (TKPH)

Tire selection and machine operating practices have, in some cases, become the critical factors in the over-all success of earthmoving ventures. One of the most serious problems occur when tires are operated at temperatures above their capabilities. Separation and related failures occur. To help you avoid temperature related failures, Caterpillar has been instrumental in developing the *Ton-Kilometer Per Hour (TKPH)*, also known as *Ton-Mile Per Hour (TMPH)*, method of rating tires. The formula to convert a TKPH rating to a TMPH rating is:

$$\text{TMPH} = \text{TKPH} \times 0.685$$

### Heat and Tire Failure

Tire manufacturing requires heat in the vulcanizing process converting crude rubber and additives into a homogeneous compound. The heat required is typically above 132° C (270° F).

A tire also generates heat as it rolls and flexes. Heat generated faster than it can be radiated into the atmosphere gradually builds within the tire and reaches maximum level at the outermost ply or belt.

Over time, enough heat can develop from overflexing to actually reverse the vulcanizing process or “revert” the rubber causing ply separation and tire failure. Only a brief time at reversion temperature initiates the failure. Experience shows that few pure heat separation cases occur. Most so-called heat separations are in tires operating below the reversion level.

As a tire’s operating temperature increases the rubber and textiles within significantly lose strength. The tire becomes more susceptible to failures from cornering, braking, impact, cut through, fatigue and heat separation. If operating tires at higher temperatures is absolutely necessary, it is essential the machines be operated to reduce the probability of premature tire failure. No hard cornering without superelevation, no panic braking, etc.

The TKPH formula was developed to predict tire temperature buildup. The system is a method of rating tires in proportion to the amount of work they can do from a temperature standpoint. It utilizes the product of *load* × *speed* to derive an index of the tire temperature buildup. Even at or below a tire’s TKPH, failures may be initiated by overstressing the tires.

It is possible by using a needle type pyrometer to measure temperature at any desired point within the tire casing. However, the instrumentation and the technique does not lend itself to general field use. The greatest difficulty is locating the thickest (therefore the hottest) tread bar in any given tire using giant calipers. The tire must then be drilled along the centerline of this bar from shoulder to shoulder at 52 mm (2") intervals. These 3.18 mm (1/8") diameter holes extend down through the tread and undertread to the topmost reinforcement. This procedure is fully described under SAE Recommended practice J1015.

The TKPH rating system as given in this SAE specification is approved by most tire manufacturers. Michelin, in addition to providing TKPH ratings has developed their own speed/load carrying rating system and we recommend that Michelin be consulted where high tire temperatures are a concern.

Heat generation in a specific tire at recommended pressure depends on three factors:

- the weight the tire is carrying (flex per revolution),
- the speed the tire is traveling over the ground (flexures over a period of time), and
- the air temperature surrounding the tire (ambient temperature) and road surface temperature.

Once a tire manufacturer has determined a tire’s temperature characteristics and expressed them in TKPH, the above listed specific job conditions can be used to determine any tire’s maximum work capacity. These conditions provide on site ability to predict and avoid costly tire separations.

### Ton-Kilometer-Per-Hour Rating System

The tire TKPH can be matched to the site TKPH as well as compared with TKPH values of different makes and types of tires.

#### TKPH Job Rate

Average Tire Load × Average Speed for the shift

#### Average Tire Load

$$\frac{\text{“Empty” tire load} + \text{“loaded” tire load}}{2}$$

#### Average Speed

$$\frac{\text{Round trip distance in kilometers} \times \text{number of trips}}{\text{Total Hours (in the shift)}}$$

For excessive haul length (32 kilometers or more) consult your tire representative for modification to the TKPH value.

To use in the United States Customary System, change kilometers to miles and use short tons.

It should be noted that prolonged operation at high casing temperatures can fatigue the nylon at the flex points in the sidewalls.

The following are the most recent TKPH ratings as made available by Goodyear, Michelin and Bridgestone, and are subject to change on their part at any time. Other tire manufacturers' TKPH ratings will be included in future handbook editions when and if made available. For latest TKPH ratings, consult specific tire manufacturer at time of machine and/or tire purchase.

### Load-and-Carry TKPH

The wheel loader, when used in load-and-carry applications, may encounter temperature problems similar to those normally associated only with tires on scrapers, trucks and wagons. **Do not place the vehicle in load-and-carry applications without first consulting the tire manufacturer, or obtaining maximum load and speed ratings and pressure recommendations from the tire manufacturer.**

### Conventional and Radial Steel Cord Tire Options

Tire options now provide types to operate in conditions ranging from rock and abrasive materials, to jobs with high speed hauls in good materials.

The best tire type can be different for the drive tires than for other tires on the same machine. TKPH should be calculated for all tires.

### TIRE DRIVE-AWAY RECOMMENDATIONS

Heat separation can be a problem during machine delivery and moving machines from one job to another. Whenever roading earthmoving machines, *check your supplier for the tire manufacturer's recommended speed limitations on the specific tires involved.*

Some tire manufacturers also recommend that vehicles equipped with extra tread depth or special compounded tires should not be roaded without their specific approval. Our tests support this recommendation, especially for L-3, L-4, E-4 and L-5 tires.

**TKPH RATINGS**  
**AT 38° C (100° F) AMBIENT TEMPERATURE**  
**For Haul Lengths of 32 km (20 miles) or Less One Way**  
**Maximum Speed Not to Exceed 48 km (30 miles) per Hour**

*Because of the variance between specific tires it is recommended that at the time of purchase you check with your tire supplier for the manufacturer's specific TKPH ratings for the tires purchased.*

**GOODYEAR RADIAL PLY CONSTRUCTION CONVENTIONAL SIZES**

Industry Code		E-3																	
		GP-2B			GP-3D			RL-2+			RL-3+			RT-3A			RT-3A+		
Tread Design	Custom Code	2S	4S	6S	2S	4S	6S	2S	4S	6S	2S	4S	6S	2S	4S	6S	2S	4S	6S
17.5R25	<b>TKPH</b>	200	150	140				150	110										
18.00R33	<b>TKPH</b>																		
21.00R33	<b>TKPH</b>																		
23.5R25	<b>TKPH</b>	260	200	170				200	150										
24.00R35	<b>TKPH</b>										440	340	260						
26.5R25	<b>TKPH</b>	280	230	190				230	170										
27.00R49	<b>TKPH</b>	660	550																
29.5R25	<b>TKPH</b>	340	270	230				270	200										
29.5R29	<b>TKPH</b>																		
33.00R51	<b>TKPH</b>																		
33.25R29	<b>TKPH</b>													420	320				
37.00R57	<b>TKPH</b>																		
40.00R57	<b>TKPH</b>																		
40.5/75R39	<b>TKPH</b>	580	450	350													550	420	320
46/90R57	<b>TKPH</b>																		
750/65R25	<b>TKPH</b>				240	180	110	230	170	110									

**TKPH RATINGS**  
**AT 38° C (100° F) AMBIENT TEMPERATURE**  
**For Haul Lengths of 32 km (20 miles) or Less One Way**  
**Maximum Speed Not to Exceed 48 km (30 miles) per Hour**

*Because of the variance between specific tires it is recommended that at the time of purchase you check with your tire supplier for the manufacturer's specific TKPH ratings for the tires purchased.*

**GOODYEAR RADIAL PLY CONSTRUCTION CONVENTIONAL SIZES**

Industry Code	E-4																				
	GT-4B			RL-4			RL-4B			RL-4H			RL-4J			RL-4JII			RM-4A+		
Tread Design	2S	4S	6S	2S	4S	6S	2S	4S	6S	2S	4S	6S	2S	4S	6S	2S	4S	6S	2S	4S	6S
Custom Code	2S	4S	6S	2S	4S	6S	2S	4S	6S	2S	4S	6S	2S	4S	6S	2S	4S	6S	2S	4S	6S
18.00R33 TKPH							230	175	130				230	175	130						
21.00R33 TKPH							300	230	190												
24.00R35 TKPH							390	300	230				390	300	230						
27.00R49 TKPH	525	400	305	640	490		550	420	330	500	385	295	545	440	265	545	440	265			
33.00R51 TKPH										685	525	365				755	575	395			
37.00R57 TKPH																			1125	860	515
40.00R57 TKPH							1260	965	570												
46/90R57 TKPH							1325	1010	595												



**Tires**

**TKPH Rating**

- Goodyear Radial Ply — Conventional Sizes

**TKPH RATINGS  
AT 38° C (100° F) AMBIENT TEMPERATURE  
For Haul Lengths of 32 km (20 miles) or Less One Way  
Maximum Speed Not to Exceed 48 km (30 miles) per Hour**

*Because of the variance between specific tires it is recommended that at the time of purchase you check with your tire supplier for the manufacturer's specific TKPH ratings for the tires purchased.*

**GOODYEAR RADIAL PLY CONSTRUCTION CONVENTIONAL SIZES**

Industry Code	E-4									G-4			L-4			L-5			L-3			
	RT-4A			RT-4A+			GP-4B-AT			GP-4C			RL-4K			RL-5K			RT-3B			
Custom Code	2S	4S	6S	2S	4S	6S	2S	4S	6S	2S	4S	6S	2S	4S	6S	2S	4S	6S	2S	4S	6S	
17.5R25 TKPH																						110
18.00R33 TKPH	230	180	140																			
23.5R25 TKPH							200	150	130	200	150	130					80	70				
24.00R35 TKPH				400	300	240																
26.5R25 TKPH							210	160	130													
27.00R49 TKPH				600	465	360																
29.5R25 TKPH							240	190	150					130	120		100	100				
29.5R29 TKPH																	120	110				

**TKPH RATINGS**  
**AT 38° C (100° F) AMBIENT TEMPERATURE**  
**For Haul Lengths of 32 km (20 miles) or Less One Way**  
**Maximum Speed Not to Exceed 48 km (30 miles) per Hour**

*Because of the variance between specific tires it is recommended that at the time of purchase you check with your tire supplier for the manufacturer's specific TKPH ratings for the tires purchased.*

**BRIDGESTONE RADIAL PLY CONSTRUCTION CONVENTIONAL SIZES**

Industry Code	E-2						E-3											
	VKT			VFT			VMT			VJT			VLT			VRL		
Tread Design	E1A	E2A	E3A	E1A	E2A	E3A	E1A	E2A	E3A	E1A	E2A	E3A	E1A	E2A	E3A	E1A	E2A	E3A
Custom Code	E1A	E2A	E3A	E1A	E2A	E3A	E1A	E2A	E3A	E1A	E2A	E3A	E1A	E2A	E3A	E1A	E2A	E3A
17.5R25 TKPH		95					144											
18.00R33 TKPH																		
21.00R33 TKPH																		
23.5R25 TKPH	263	205						190			190							
24.00R35 TKPH																		
26.5R25 TKPH							293	220			220							
27.00R49 TKPH					557	804												
29.5R25 TKPH	376	310												266				
29.5R29 TKPH	401	330																
33.00R51 TKPH																		
33.25R29 TKPH													476	349		435	319	
37.00R57 TKPH																		
37.25R35 TKPH	644	530											569	417		563	413	
40.00R57 TKPH																		
40.5/75R39 TKPH													682	500		675	495	
46/90R57 TKPH																		
750/65R25 TKPH														225				
59/80R63 TKPH																		

**NOTE:** For cycle lengths of 5 km (3 miles) or less (round trip), multiply the TKPH value in this table by 1.12.  
 Additional tread compounds are available to meet specific TKPH.

**TKPH RATINGS  
AT 38° C (100° F) AMBIENT TEMPERATURE  
For Haul Lengths of 32 km (20 miles) or Less One Way  
Maximum Speed Not to Exceed 48 km (30 miles) per Hour**

*Because of the variance between specific tires it is recommended that at the time of purchase you check with your tire supplier for the manufacturer's specific TKPH ratings for the tires purchased.*

**BRIDGESTONE RADIAL PLY CONSTRUCTION CONVENTIONAL SIZES**

Industry Code		E-4											
		VMTS			VELS			VMTP			VRQP		
Tread Design	Custom Code	E1A	E2A	E3A	E1A	E2A	E3A	E1A	E2A	E3A	E1A	E2A	E3A
18.00R33	<b>TKPH</b>	246	199		211	170	246	229	185			122	
21.00R33	<b>TKPH</b>							293	237				
24.00R35	<b>TKPH</b>	418	338	489				388	314				
27.00R49	<b>TKPH</b>	492	398						361	522			
40.00R57	<b>TKPH</b>				940	773	1117						

**NOTE:** For cycle lengths of 5 km (3 miles) or less (round trip), multiply the TKPH value in this table by 1.12.  
Additional tread compounds are available to meet specific TKPH.

**TKPH RATINGS**  
**AT 38° C (100° F) AMBIENT TEMPERATURE**  
**For Haul Lengths of 32 km (20 miles) or Less One Way**  
**Maximum Speed Not to Exceed 48 km (30 miles) per Hour**

*Because of the variance between specific tires it is recommended that at the time of purchase you check with your tire supplier for the manufacturer's specific TKPH ratings for the tires purchased.*

**BRIDGESTONE RADIAL PLY CONSTRUCTION CONVENTIONAL SIZES**

Industry Code		E-4											
		VRLS			VLTS			VSNT			VRDP		
Tread Design	Custom Code	E1A	E2A	E3A	E1A	E2A	E3A	E1A	E2A	E3A	E1A	E2A	E3A
21.00R33	TKPH	281	227										
23.5R25	TKPH					161							
24.00R35	TKPH	388	314	453									
26.5R25	TKPH					186			165				
27.00R49	TKPH	513	415	600									
29.5R25	TKPH					225			220				
29.5R29	TKPH								232				
33.00R51	TKPH	603	496	717									
37.00R57	TKPH	845	694	1009									
46/90R57	TKPH										968	796	1150
750/65R25	TKPH					195							
59/80R63	TKPH										1515	1228	1773

**NOTE:** For cycle lengths of 5 km (3 miles) or less (round trip), multiply the TKPH value in this table by 1.12.  
 Additional tread compounds are available to meet specific TKPH.

# Tires

## TKPH Rating

- Michelin Radial Ply — Conventional Sizes

**TKPH RATINGS**  
**AT 38° C (100° F) AMBIENT TEMPERATURE**  
**For Haul Cycles Less than 5 km (3 miles) Round Trip**

*Because of the variance between specific tires it is recommended that at the time of purchase you check with your tire supplier for the manufacturer's specific TKPH ratings for the tires purchased.*

**MICHELIN RADIAL PLY CONSTRUCTION CONVENTIONAL SIZES**

Industry Code	E-2	E-3			E-4					
		XV	XR	XK	XKD1	X-QUARRY S	XDT			X-HAUL
Tread Design	C	B	B	A		A4	A	B		
18.00R33 <b>TKPH</b>		305		157	166	157	192	262	262	
21.00R33 <b>TKPH</b>										280
24.00R35 <b>TKPH</b>	740	518	474		281	266	326	444	355	
27.00R49 <b>TKPH</b>	1090					392	480	654		
33.00R51 <b>TKPH</b>						558	682	930		

**NOTE:** Consult Michelin for TKPH rating on haul cycles greater than 5 km (3 miles).  
 Additional tread compounds are available to meet specific TKPH.

**TKPH RATINGS**  
**AT 38° C (100° F) AMBIENT TEMPERATURE**  
**For Haul Cycles Less than 5 km (3 miles) Round Trip**

*Because of the variance between specific tires it is recommended that at the time of purchase you check with your tire supplier for the manufacturer's specific TKPH ratings for the tires purchased.*

**MICHELIN RADIAL PLY CONSTRUCTION CONVENTIONAL SIZES**

Industry Code	E-4											
	Tread Design	XDR					XDR S			X-TRACTION RD		
Type		A	B4	B	C4	C	B4	B	C4	A4	B	B4
27.00R49	TKPH	392	480	567						392	654	567
33.00R51	TKPH	496	620	744	837							
37.00R57	TKPH	678	848	1018	1145							
40.00R57	TKPH	768	960	1152	1296	1440						
50/80R57	TKPH		1168	1285	1518							
56/80R63	TKPH	1229	1536	1843	2150							
59/80R63	TKPH	1267	1584	1901	2218		1901	2218	2535			

**NOTE:** Consult Michelin for TKPH rating on haul cycles greater than 5 km (3 miles).  
 Additional tread compounds are available to meet specific TKPH.

**TKPH RATINGS  
AT 38° C (100° F) AMBIENT TEMPERATURE  
For Haul Cycles Less than 5 km (3 miles) Round Trip**

*Because of the variance between specific tires it is recommended that at the time of purchase you check with your tire supplier for the manufacturer's specific TKPH ratings for the tires purchased.*

**MICHELIN RADIAL PLY CONSTRUCTION CONVENTIONAL SIZES**

Industry Code	E-4								
	X-TRACTION S RD		XDC			XDM			
Tread Design	A	B	B4	C	C4	B4	B	C4	C
27.00R49 <b>TKPH</b>	589	763							
33.00R51 <b>TKPH</b>			1054	1209	1395	848	1018		
40.00R57 <b>TKPH</b>						1056	1248	1440	1584

**NOTE:** Consult Michelin for TKPH rating on haul cycles greater than 5 km (3 miles).  
Additional tread compounds are available to meet specific TKPH.

**TKPH RATINGS  
AT 38° C (100° F) AMBIENT TEMPERATURE  
For Haul Cycles Less than 5 km (3 miles) Round Trip**

*Because of the variance between specific tires it is recommended that at the time of purchase you check with your tire supplier for the manufacturer's specific TKPH ratings for the tires purchased.*

**MICHELIN RADIAL PLY CONSTRUCTION WIDE BASE SIZES**

Industry Code	E-3			E-4
Tread Design	XTS	XMS		XRS
Type		B	A	
29.5R29 <b>TKPH</b>	348			
33.25R29 <b>TKPH</b>	429			
37.25R35 <b>TKPH</b>	540			415
40.5/75R39 <b>TKPH</b>		766	500	

**NOTE:** Consult Michelin for TKPH rating on haul cycles greater than 5 km (3 miles).

**ISO LOAD INDEX SPEED SYMBOL  
AT 38° C (100° F) AMBIENT TEMPERATURE  
For Haul Cycles Greater than 5 km (3 miles) Round Trip**

*Because of the variance between specific tires it is recommended that at the time of purchase you check with your tire supplier for the manufacturer's specific TKPH ratings for the tires purchased.*

**MICHELIN RADIAL PLY CONSTRUCTION WIDE BASE SIZES**

Industry Code	E-3	E-3 (DT)	E-3	E-4
Tread Design	XADN	XADT	XAD65-1	X SUPER TERRAIN
23.5R25	185B*	185B		185B
26.5R25	193B	193B		193B
29.5R25	200B*	200B		200B
650/65R25 SuperE3			180B	
750/65R25 SuperE3			190B	
850/65R25 SuperE3			196B	

\*E Speed option available via special field request.



## TIRE AND RIM ASSOCIATION RATINGS

While the TKPH Rating System provides a method to determine the tire's work capacity, Tire and Rim Association Ratings provide a guide for evaluating a tire's structural capacity. These two rating systems should be used in conjunction to evaluate tire performance.

## TIRE SELECTION

Selecting the optimum tire for a given application is particularly critical for earthmoving. The machines have the capability to outperform the tires and, unless proper practices are observed, very costly premature tire failures can occur. Job conditions vary greatly throughout the world, as well as within any given job site, and selecting the optimum tire requires careful consideration of all factors involved. In general, the tire manufacturer should be consulted before making the selection for any given application. In some cases, the tire manufacturer can fabricate tires specifically tailored for a given job site.

For those applications where wear is extremely slow, especially as a result of only occasional operation throughout the year, the cheapest lightweight tire needs to be given strong consideration.

As job conditions become severe, the following factors should be evaluated in selecting a tire:

### *Transport or Load-and-carry —*

- TKPH (primary consideration)
- Minimum approved star/ply rating or greater
- Largest optional size
- Thickest tread commensurate with TKPH
- Most cut resistant tread commensurate with TKPH
- Belted construction

### *Grader —*

- Tire load rating suitable for maximum equipped machine weight (See Tire Load Worksheet on next page)
- Application specific tire (snow, construction, road maintenance, mining, general purpose, all season)
- Bias or radial based on initial cost, puncture resistance, rolling resistance, life to retread/repair

### *Loader or Dozer —*

- Minimum approved ply rating or greater
- Largest optional size
- Thickest tread
- Thickest available undertread
- Buttressed shoulder
- Most cut resistant tread
- Belted construction
- Lowest aspect ratio

All tires should be operated at the tire manufacturer's recommended inflation pressure for a given application. Inflation pressure should be checked every working day with an accurate gauge. This gauge should be checked against a known standard such as a dead weight tester at least once a month.

Excess loads may result from factors such as varying material density, field modifications to equipment, mud accumulation, load transfer, etc. Only under these conditions may the actual in service tire load exceed the rated machine load. When excess loads are encountered, cold inflation pressures **must** be increased to compensate for higher loads. Increase tire inflation pressure 2% for each 1% increase in load.

	Maximum Excess	
	Load	Pressure
Bias Ply	15%	30%
Radial Ply	7%	14%

The above loads will result in reduced tire performance and must be approved by the tire manufacturer.

The use of chains is difficult to justify except under a few conditions. Chains are very costly and heavy, and require more maintenance than most operations can provide. On some models sufficient clearance does not exist for chains with all tire combinations. Extensive modifications may be required if chains are needed for the job.

Foam filling tires is normally not recommended due to high cost and lack of local filling facilities. Its use should be confined to loader and dozer applications where penetrations occur almost daily. If foam is used be sure to adhere to recommended equivalent pressures of nitrogen and use highest available ply rating. Consult tire manufacturer for specific warranty concerns.

### Tire Load Worksheet (Motor Graders)

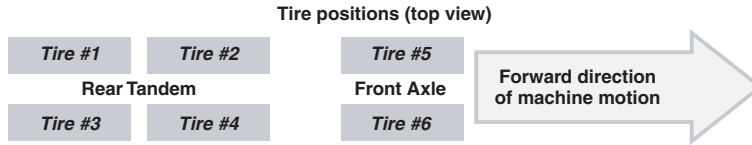

**A Machine information:**

Base operating weight (kg) (1a) = \_\_\_\_\_  
 Rear operating weight (%) (2a) = \_\_\_\_\_  
 Front operating weight (%) (3a) = \_\_\_\_\_

**B Tire loads:**

Weight on rear tire before attachments (kg) (1b) =  $\frac{(1a) \times (2a)}{4}$  = \_\_\_\_\_ (Tires # 1, 2, 3, 4)  
 Weight on front tire before attachments (kg) (2b) =  $\frac{(1a) \times (3a)}{2}$  = \_\_\_\_\_ (Tires # 5, 6)

**C Attachment information (reference Caterpillar Price List):**

Attachment Type	Tires affected	Attachment weight distribution
Ripper	1, 2, 3, 4	25% per tire
Push Block	5, 6	50% per tire
Front blade (any type)	5, 6	62% per tire
Mid-Mount Scarifier	5, 6	40% per tire
	1, 2, 3, 4	5% per tire
Snow Wing	6	34% per tire
	3, 4	55% per tire

**Attachment #1** Attachment type: \_\_\_\_\_ Attachment weight (kg) (1c) = \_\_\_\_\_

Tire positions affected (see chart) \_\_\_\_\_  
 \_\_\_\_\_ Tire #1 \_\_\_\_\_ Tire #2 \_\_\_\_\_ Tire #3 \_\_\_\_\_ Tire #4 \_\_\_\_\_ Tire #5 \_\_\_\_\_ Tire #6 \_\_\_\_\_

Attachment weight distribution per tire (see chart) (2c) = \_\_\_\_\_  
 Attachment weight per tire (kg) = (1c) × (2c) (3c) = \_\_\_\_\_

**Attachment #2** Attachment type: \_\_\_\_\_ Attachment weight (kg) (4c) = \_\_\_\_\_

Tire positions affected (see chart) \_\_\_\_\_  
 \_\_\_\_\_ Tire #1 \_\_\_\_\_ Tire #2 \_\_\_\_\_ Tire #3 \_\_\_\_\_ Tire #4 \_\_\_\_\_ Tire #5 \_\_\_\_\_ Tire #6 \_\_\_\_\_

Attachment weight distribution per tire (see chart) (5c) = \_\_\_\_\_  
 Attachment weight per tire (kg) = (4c) × (5c) (6c) = \_\_\_\_\_

**Attachment #3** Attachment type: \_\_\_\_\_ Attachment weight (kg) (7c) = \_\_\_\_\_

Tire positions affected (see chart) \_\_\_\_\_  
 \_\_\_\_\_ Tire #1 \_\_\_\_\_ Tire #2 \_\_\_\_\_ Tire #3 \_\_\_\_\_ Tire #4 \_\_\_\_\_ Tire #5 \_\_\_\_\_ Tire #6 \_\_\_\_\_

Attachment weight distribution per tire (see chart) (8c) = \_\_\_\_\_  
 Attachment weight per tire (kg) = (7c) × (8c) (9c) = \_\_\_\_\_

**NOTE: Repeat for additional attachments if needed.**

**D Sum of attachment weights and Total weight per tire (kg)**

\_\_\_\_\_ Tire #1 \_\_\_\_\_ Tire #2 \_\_\_\_\_ Tire #3 \_\_\_\_\_ Tire #4 \_\_\_\_\_ Tire #5 \_\_\_\_\_ Tire #6 \_\_\_\_\_

(1d) = (3c) + (6c) + (9c) = \_\_\_\_\_  
 (2d) = (1d) + [(1b) or (2b)] = \_\_\_\_\_

**E Controlling tire weight = maximum value from (2d) (1e) = \_\_\_\_\_ kg**

- F Summary**
- Choose a tire with a rated load capacity equal to or greater than the controlling tire weight = Tire rating > (1f)
  - Attachments may cause the maximum weight per tire to exceed tire capacity. In these cases the tire supplier should be consulted.
  - Contact your tire supplier for machine specific inflation pressures to ensure compensation for different tire loads.

**TIRE SELECTION GUIDE**

Material	Road or Ground Condition	Treads		
		Trucks and Wheel Tractor-Scrapers	Wheel Tractors or Wheel Loaders	Graders*
Silt and clay: – No rock. – High moisture content.	Good varying to poor. High rolling resistance.	Traction Type (E-2).	Traction Type (L-2).	Traction Type (G-2).
Silt and clay: – Some rock. – Variable moisture content.	Good varying to poor.	Rock-type (E-3) best unless traction is a problem — then use traction tires (E-2). Rock-type offers more resistance to cutting.	Rock-type (L-3, L-4, L-5) best unless traction is a problem — then use traction tires (L-2). Rock-type offers more resistance to cutting.	Rock-type (G-3, G-4) best unless traction is a problem — then use traction tires (G-2). Rock-type offers more resistance to cutting.
Silty/clayey gravel/sand: – Low moisture content.	Excellent to good. Firm surface.	Rock-type (E-3, E-4) offers better wear.	Rock-type (L-3, L-4, L-5) offers better wear.	Rock-type (G-3, G-4, L-3, L-4, L-5) offers better wear.
Silty/clayey gravel/sand: – High moisture content.	Poor, rutted, pot holes.	Rock-type (E-3, E-4).	Rock-type (L-3, L-4, L-5).	Rock-type (G-3, G-4, L-3, L-4, L-5).
Blasted rock.	Hard surface, rough.	Rock-type (E-4).	Rock-type (L-5, L-5S).	Rock-type (G-4, L-4, L-5).
Sand – Very low silt/clay content.	Good to fair surface.	Rock-type (E-3) or Flotation (E-7) if possible with low pressure. Creates minimum soil disturbance resulting in improved flotation.	Rock-type (L-3, L-3S) with low pressure. Creates minimum soil disturbance resulting in improved flotation.	Rock-type (G-3) with low pressure. Creates minimum soil disturbance resulting in improved flotation.

\*NOTE: In some cases, an L type tire is appropriate for use on a Grader application, consult your tire supplier for proper tire selection.

## RECOMMENDED MOUNTING LUBRICANTS FROM SUPPLIERS

The following table documents tire supplier recommendations for Tire Mounting Compounds.

### Tire Mounting Compounds

Tire-Slick  
 Michelin “Tigre 80” Grease  
 REMA Tiptop  
 Fuchs Silkolene  
 IZY-SEEL

## TIRE SUPPLIER RECOMMENDED COLD INFLATION PRESSURES

The following tables present commonly found Caterpillar and the *tire suppliers’* recommended cold inflation pressures for tires on Cat machines. For inflation pressures of tire suppliers not listed please obtain them directly from the respected supplier.

The inflation pressure is based on a ready-to-work vehicle weight, rated payload, and average operating conditions. **Pressures for each application may need to be varied from those shown and should always be obtained from your tire supplier.**

Pressures for all tires apply to rib, traction, rock, deep tread, and super deep tread tires.

**NOTE:** Caterpillar recommends using dry nitrogen (N<sub>2</sub>) gas for both tire inflation and pressure adjustments on all current and past production machines.

## EXCAVATORS

For complete tire data and inflation pressures, see the Excavator section in this handbook.

*Optimal pressures may vary depending on specific applications and working conditions. Always consult your local tire supplier for operating pressures.*

## STANDARD COLD INFLATION PRESSURES SKIDDERS — Bias Ply

Model	Tire Size	Ply Rating	Inflation Pressure			
			Front		Rear	
			kPa	psi	kPa	psi
525C,	30.5L-32	20	170	25	170	25
535C,	30.5L-32	26	170	25	170	25
545C	DH35.5LB32	20	170	25	170	25
	DH35.5LB32	24	170	25	170	25

## Tires

### Standard Cold Inflation Pressures

- Skid Steer Loaders — Bias and Bias Belted
- Telehandlers

*Optimal pressures may vary depending on specific applications and working conditions. Always consult your local tire supplier for operating pressures.*

### SKID STEER LOADERS — Bias and Bias Belted

Model	Tire Size	Ply Rating	Inflation Pressure							
			Galaxy Beefy Baby		Caterpillar Premium Conventional		Caterpillar XD (Extreme Duty)		Michelin XZSL	
			kPa	psi	kPa	psi	kPa	psi	kPa	psi
216B2	10-16.5	8, 10 for XD	345	50	410	60	345	50	310	45
226B2	10-16.5	8, 10 for XD	345	50	410	60	345	50	310	45
236B2	12-16.5	10, 14 for XD	310	45	310	45	345	50	310	45
232B2	10-16.5	8, 10 for XD	345	50	410	60	345	50	380	55
242B2	10-16.5	8, 10 for XD	345	50	410	60	345	50	380	55
	12-16.5	10, 14 for XD	310	45	310	45	345	50	310	45
252B2	12-16.5	10, 14 for XD	310	45	310	45	345	50	345	50
246C	12-16.5	10, 14 for XD	310	45	310	45	345	50	345	50
256C	12-16.5	10, 14 for XD	310	45	310	45	345	50	345	50
262C	12-16.5	10, 14 for XD	310	45	310	45	345	50	345	50
272C	12-16.5	10, 14 for XD	310	45	310	45	345	50	345	50

### TELEHANDLERS

Model	Tire Size	Ply Rating	Inflation Pressure	
			kPa	psi
TL642	13.00 x 24	12	448	65
TL943	13.00 x 24	12	448	65
TL1055	14.00 x 24	12	448	65
TL1255	14.00 x 24	12	448	65
TH255	12.00 x 16.5	12	551	80
	14.00 x 17.5	10	482	70
TH406	15.5/80 – 24 400/80R24 460/70R24	16	See machine OMM for operating pressures.	
	15.5 – 25 15.5/80 – 24	16		
TH407	15.5/80 – 24 400/80R24 440/80R24 460/70R24 500/70R24	16		
	15.5 – 25			
	15.5/80 – 24	16		

*Optimal pressures may vary depending on specific applications and working conditions. Always consult your local tire supplier for operating pressures.*

**BACKHOE LOADERS (Front)**

Model	Tire Size	Ply/Speed Symbol	Inflation Pressure	
			kPa	psi
416E, 420E, 422E	11Lx16 (F3)	12	441	64
416E, 420E, 422E, 428E, 430E, 432E, 442E	12.5/80-18 (1-3)	12	372	54
416E, 420E, 422E, 428E, 430E, 432E, 442E, 442E AWS	340/80R18	142 A8	400	58
450E	15-19.5	12	414	60
428E, 432E, 442E	340/80R20	144 A8	317	46
434E	440/80R24	154 A8	317	46
434E, 444E	440/80R28	156 A8	317	46
434E, 444E	440/80-28	12	317	46

**BACKHOE LOADERS (Rear)**

Model	Tire Size	Ply/Speed Symbol	Inflation Pressure	
			kPa	psi
416E	16.9-24 (R-4)	10	221	32
416E, 420E, 430E	19.5L-24 (R-4)	12	234	34
422E, 428E, 432E	16.9-28 (R-4)	12	262	38
428E, 432E, 442E	18.4-26 (R-4)	12	248	36
434E	440/80R24	154 A8	317	46
422E, 428E, 432E, 442E, 442E AWS, 434E, 444E	440/80R28	156 A8	317	46
428E, 432E, 442E, 442E AWS, 434E, 444E	440/80-28 (R-4)	12	317	46
428E, 432E, 442E	480/80-26 (R-4)	160 A8	317	46
416E, 420E, 430E, 450E	21L-24 (R-4)	16/18	276/310	40/45
416E, 420E, 430E	500/70R24	157 A8	400	58

*Optimal pressures may vary depending on specific applications and working conditions. Always consult your local tire supplier for operating pressures.*

**PAVING PRODUCTS — Bias Ply and Radial Pneumatic Tires**

Model	Tire Size	Ply/Strength Rating	Inflation Pressure <sup>1, 2, 3</sup>	
			kPa	psi
CS323C	11.2 – 24	6	180	26
	11.2 – 24	8	250	36
CP323C	11.2 – 24	8	250	36
CS423E	14.9 – 24	6	140	20
	14.9 – 24	8	180	26
CS433E	14.9 – 24	6	140	20
	14.9 – 24	8	180	26
CP433E	14.9 – 24	8	180	26
CS54	23.1 – 26	8	110	16
CS56	23.1 – 26	8	110	16
CP56	23.1 – 26	8	110	16
CS64	23.1 – 26	8	110	16
	23.1 – 26	12	110	16
CP64	23.1 – 26	12	110	16
CS74	23.1 – 26	8	110	16
	23.1 – 26	12	110	16
CS76	23.1 – 26	12	110	16
CP76	23.1 – 26	12	110	16
AP500E	17.5R25	★	450	65
AP600D	16.00 – 24	12	350	50
	445/95R25	★★	550	80
AP1000D	18.00 – 25	16	350	50
	445/95R25	★★	550	80

<sup>1</sup>Inflation pressures are maximum rated tire pressures.

<sup>2</sup>Pressure varies with application for Pneumatic Tire Compactors (PS).

<sup>3</sup>Consult your local tire supplier for operating pressures.

Optimal pressures may vary depending on specific applications and working conditions. Always consult your local tire supplier for operating pressures.

**MOTOR GRADERS — Bias Ply\***

Model	Tire Size	Ply Rating	Inflation Pressure											
			Goodyear				Bridgestone/Firestone				Triangle			
			Front		Rear		Front		Rear		Front		Rear	
		kPa	psi	kPa	psi	kPa	psi	kPa	psi	kPa	psi	kPa	psi	
120M	13.00-24	12					240	35	345	50				
	14.00-24	12					210	30	275	40				
	17.5-25	12	175	25	250	36	210	30	275	40				
		16	175	25	200	29	210	30	275	40				
120K	13.00-24	10					240	35	240	35				
	14.00-24	12	225	33	225	33	240	35	240	35	225	33	225	33
		10												
	17.5-25	12	175	25	175	25	250	36	250	36				
16		175	25	175	25	250	36	250	36	200	29	200	29	
12M	13.00-24	12					210	30	275	40				
	14.00-24	16					210	30	275	40				
		12	175	25	250	36	210	30	275	40				
	17.5-25	16	200	29	300	44	210	30	275	40				
12		175	25	225	33	210	30	240	35					
12K	13.00-24	16	200	29	300	44	210	30	240	35				
		12	275	40	275	40								
	17.5-25	12	200	29	200	29	250	36	250	36	350	51	350	51
		16	200	29	200	29	250	36	250	36	325	47	325	47
140M	14.00-24	12	175	25	275	40	210	30	275	40				
		16	225	33	350	51	210	30	275	40				
	17.5-25	12					210	30	275	40				
		16	175	25	250	36	210	30	275	40				
140K	14.00-24	12	175	25	175	25	250	36	250	36	350	51	350	51
		16	175	25	175	25								
	17.5-25	12					250	36	250	36				
14M	16.00-24	16	200	29	300	44	175	25	310	45				
160M	14.00-24	12					210	30	275	40				
		16	250	36	375	54	210	30	275	40				
	17.5-25	12	200	29	200	29	250	36	250	36				
16		200	29	200	29									
160K	14.00-24	12					250	36	250	36	350	51	350	51
		16												
	17.5-25	12					250	36	250	36				
		20								325	47	325	47	

\*Refer to Tire Load Worksheet to determine proper ply rating.



*Optimal pressures may vary depending on specific applications and working conditions. Always consult your local tire supplier for operating pressures.*

**MOTOR GRADERS — Radial Ply**

Model	Tire Size	Strength Rating	Inflation Pressure											
			Michelin		Goodyear		Bridgestone							
			Front	Rear	Front	Rear	Front	Rear						
			kPa	psi	kPa	psi	kPa	psi	kPa	psi				
<b>120M</b>	14.00R24	★	240	35	275	40	275	40	325	47	240	35	310	45
	17.5R25	★	210	30	240	35	225	33	275	40	210	30	240	35
<b>120K</b>	14.00R24	★	210	30	210	30					240	35	310	45
<b>12M</b>	14.00R24	★	210	30	310	45	250	36	375	54	240	35	310	45
	17.5R25	★	210	30	240	35	225	33	300	44	210	30	275	40
<b>12K</b>	14.00R24	★	210	30	240	35					240	35	310	45
<b>140M</b>	14.00R24	★	210	30	310	45	275	40	375	54	240	35	310	45
	17.5R25	★	240	35	310	45	225	33	300	44	210	30	240	35
<b>140K</b>	14.00R24	★	210	30	240	35					240	35	310	45
<b>14M</b>	16.00R24	★	240	35	350	50	275	40	375	54	240	35	380	55
	20.5R25	★	210	30	275	40	200	29	300	44	210	30	210	45
<b>160M</b>	14.00R24	★	210	30	310	45	300	44	425	62	240	35	310	45
	17.5R25	★	240	35	310	45	225	33	350	51	210	30	240	35
<b>160K</b>	14.00R24	★	210	30	240	35					240	35	310	45
<b>16M</b>	23.5R25	★, ★★	210	30	275	40	200	29	325	47	210	30	310	45
<b>24M</b>	29.5R25	★, ★★	310	45	380	55	350	51	450	65	310	45	380	55

*Optimal pressures may vary depending on specific applications and working conditions. Always consult your local tire supplier for operating pressures.*

**WHEEL TRACTOR-SCRAPERS — Bias Ply**

Model	Tire Size	Ply Rating	Inflation Pressure							
			Goodyear				Bridgestone/Firestone			
			Front		Rear		Front		Rear	
			kPa	psi	kPa	psi	kPa	psi	kPa	psi
613G	23.5-25	16, 20	324	47	324	47	300	44	300	44
621G	29.5-29	28, 34	427	62	427	62	379	55	379	55
	33.25-29	26, 32	400	58	276	40				
623G	33.25-29	26, 32	400	58	372	54	379	55	379	55
627G	33.25-29	26, 32	400	58	400	58	379	55	379	55
631G	37.25-35	36, 42	427	62	372	54	448	65	448	65
637G	37.25-35	36	448	65	427	62				

**WHEEL TRACTOR-SCRAPERS — Radial Ply**

Model	Tire Size	Strength Index	Inflation Pressure											
			Michelin		Goodyear				Bridgestone					
			Front	Rear	Front	Rear	Front	Rear	Front	Rear				
			kPa	psi	kPa	psi	kPa	psi	kPa	psi	kPa	psi		
613G	23.5R25	★, ★★	379	55	345	50	372	54	372	54	379	55	379	55
621G	29.5R29	★★	483	70	414	60	572	83	572	83	517	75	517	75
	33.25R29	★★	448	65	379	55	448	65	352	51	448	65	448	65
623G	29.5R29	★★	483	70	414	60	448	65	427	62	517	75	517	75
	33.25R29	★★									448	65	448	65
627G	29.5R29	★★	517	75	448	65	448	65	448	65	517	75	517	75
	33.25R29	★★									448	65	448	65
631G	37.25R35	★★	552	80	483	70	476	69	427	62	552	80	552	80
637G	37.25R35	★★	552	80	483	70	524	76	476	69	552	80	552	80
657G	40.5/75R39	★★	586	85	517	75	600	87	600	87	621	90	621	90

# Tires

## Standard Cold Inflation Pressures

- Articulated Trucks — Radial Ply
- Construction and Mining Trucks and Tractors — Radial Ply

*Optimal pressures may vary depending on specific applications and working conditions. Always consult your local tire supplier for operating pressures.*

### ARTICULATED TRUCKS — Radial Ply

Model	Tire Size	Ply Rating	Inflation Pressure																	
			Michelin						Goodyear						Bridgestone					
			Front		Center		Rear		Front		Center		Rear		Front		Center		Rear	
kPa	psi	kPa	psi	kPa	psi	kPa	psi	kPa	psi	kPa	psi	kPa	psi	kPa	psi	kPa	psi	kPa	psi	
725	23.5R25 750/65R25	★★	345	50	379	55	379	55	372	54	372	54	372	54	379	55	379	55	379	55
			276	40	310	45	310	45					310	45	310	45	310	45		
730	23.5R25 750/65R25	★★	414	60	448	65	448	65	372	54	448	65	448	65	414	60	483	70	483	70
			310	45	345	50	345	50	303	44	352	51	352	51	345	50	379	55	379	55
730 EJ	750/65R25	★★	345	50	379	55	379	55	276	40	400	58	400	58	310	45	414	60	414	60
735	26.5R25 850/65R25	★★	448	65	448	65	448	65	448	65	400	58	400	58	483	70	448	65	448	65
			345	50	345	50														
740	29.5R25 850/65R25	★★	379	55	414	60	414	60	372	54	372	54	372	54	448	65	414	60	414	60
			379	55	414	60	414	60												
740 EJ	29.5R25	★★	379	55	448	65	448	65	324	47	427	65	427	62	379	55	483	70	483	70

### CONSTRUCTION AND MINING TRUCKS — Radial Ply

Model	Tire Size	Strength Index	Inflation Pressure													
			Michelin				Goodyear				Bridgestone					
			Front		Rear		Front		Rear		Front		Rear			
kPa	psi	kPa	psi	kPa	psi	kPa	psi	kPa	psi	kPa	psi	kPa	psi	kPa	psi	
770	18.00R33	★★, ★★★	750	109	750	109	772	112	800	116	800	116	800	116	800	116
772	21.00R33	★★	655	95	655	95	700	102	700	102	690	100	690	100	690	100
773F	24.00R35	★★	725	105	725	105	675	98	600	87	690	100	690	100	690	100
775F	24.00R35	★★	725	105	725	105	720	104	720	104	690	100	690	100	690	100
777F	27.00R49	★★	725	105	725	105	700	102	730	106	690	100	690	100	690	100
785C	33.00R51	★★	725	105	725	105	800	116	800	116	725	105	725	105	725	105
785D	33.00R51	★★	725	105	725	105	800	116	800	116	725	105	725	105	725	105
789C	37.00R57	★★	655	95	655	95	750	109	750	109	725	105	725	105	725	105
793D	40.00R57 46/90R57	★★	725	105	725	105	750	109	750	109	725	105	725	105	725	105
							750	109	750	109	690	100	690	100	690	100
793F	40.00R57 46/90R57 50/80R57	★★	725	105	725	105	800	116	780	113						
							750	109	710	103	690	100	690	100	690	100
			620	90	620	90										
795F	56/80R63 59/80R63	★★	655	95	620	90					700	102	700	102	700	102
797F	59/80R63	★★	690	100	690	100					690	100	690	100	690	100

*Optimal pressures may vary depending on specific applications and working conditions. Always consult your local tire supplier for operating pressures.*

**WHEEL LOADERS — Bias and Bias Belted**

Model	Tire Size	Strength Index	Inflation Pressure <sup>1</sup>								
			Goodyear				Bridgestone/Firestone				
			Front		Rear		Front		Rear		
			kPa	psi	kPa	psi	kPa	psi	kPa	psi	
904H	12-16.5	10						240	35	175	25
	33-15.5x16.5	12									
914G	15.5-25	12	400	58	300	44	240	35	210	30	
	17.5-25	12					240	35	210	30	
924H	17.5-25	12	400	51	300	36	380	55	275	40	
	20.5-25	12	250	36	210	30	275	40	275	30	
924Hz	17.5-25	12	400	58	300	44	380	55	275	40	
	20.5-25	12	400	58	300	44	275	40	210	30	
928Hz	17.5-25	12	400	58	300	44	380	55	275	40	
	20.5-25	12	400	58	300	44	275	40	210	30	
	23.1-26	14									
930H	17.5-25	12	400	58	300	44	380	55	275	40	
	20.5-25	12	400	58	300	44	275	40	210	30	
	23.1-26	14									
938H	20.5-25	16, 20	350	51	250	36	310	45	210	30	
950H	23.5-25	16, 20	375	54	250	36	345	50	210	30	
950K	23.5-25	16, 20					345	50	345	50	
962H	23.5-25	16, 20	400	58	250	36	380	55	240	35	
962K	23.5-25	16, 20					380	55	240	35	
966H	26.5-25	20, 26	375	54	225	33	415	60	275	40	
966K	26.5-25	20, 26	450	65	300	44	415	60	275	40	
972H	26.5-25	20, 26	400	58	225	33	450	65	275	40	
972K	26.5-25	20, 26	450	65	300	44	450	65	275	40	
980H	29.5-25	28	430	62	275	40	585	85	380	55	
980K	29.5-25	28					550	80	380	55	
988H	35/65-33	42	360	91	430	62	655	95	415	60	
990H	41.25/70-39	42	550	80	350	51	585	85	415	60	
992K	45/65-45	58	625	91	425	62	725	105	485	70	
993K	50/65-51	62					725	105	485	70	
994F	49.5/85-57	76					725	105	485	70	
	50/80-57	68					725	105	485	70	
	52/80-57	68	600	87	400	58					
	53.5/85-57	76					725	105	485	70	
	58/85-57	84					725	105	485	70	

<sup>1</sup>For pressures not listed, consult your local tire supplier for operating pressures.

# Tires

## Standard Cold Inflation Pressures

- Log Loaders — Bias and Bias Belted
- Integrated Toolcarriers — Bias and Bias Belted

*Optimal pressures may vary depending on specific applications and working conditions. Always consult your local tire supplier for operating pressures.*

### LOG LOADERS — Bias and Bias Belted

Model	Tire Size	Strength Index	Inflation Pressure							
			Goodyear				Bridgestone/Firestone			
			Front		Rear		Front		Rear	
		kPa	psi	kPa	psi	kPa	psi	kPa	psi	
IT14G	15.5-25	12								
	17.5-25	12								
924H Versalink	17.5-25	12	352	51	248	36	Consult Bridgestone/Firestone			
	20.5-25	12								
930H Versalink	20.5-25	12								
938H	20.5-25	16, 20	400	58	276	40	310	45	207	30
950H	23.5-25	20	372	54	276	40	345	50	207	30
966H	26.5-25	20, 26	448	65	276	40	414	60	276	40
980H	29.5-25	28	427	62	276	40	586	85	379	55
988H	35/65-33	42					655	95	414	60

**NOTE:** Contact your tire supplier to obtain or confirm proper Log Loader pressures.

### INTEGRATED TOOLCARRIERS — Bias and Bias Belted

Model	Tire Size	Strength Index	Inflation Pressure											
			Goodyear				Bridgestone/Firestone							
			Front		Rear		Front		Rear					
		kPa	psi	kPa	psi	kPa	psi	kPa	psi					
IT14G	15.5-25		310	45	207	30	Consult Bridgestone/Firestone							
	17.5-25		276	40	172	25								
924H Versalink	17.5-25		310	45	241	35					Consult Bridgestone/Firestone			
	20.5-25		276	40	207	30								
930H Versalink	20.5-25		276	40	207	30	Consult Bridgestone/Firestone							
IT38H	20.5-25		400	58	276	40					379	55	276	40
IT62H	23.5-25		372	54	248	36					345	50	207	30

**NOTE:** Contact your tire supplier to obtain or confirm pressures.

Optimal pressures may vary depending on specific applications and working conditions. Always consult your local tire supplier for operating pressures.

**WHEEL LOADERS — Radial Ply**

Model	Tire Size	Strength Index	Inflation Pressure											
			Michelin				Goodyear				Bridgestone			
			Front		Rear		Front		Rear		Front		Rear	
kPa	psi	kPa	psi	kPa	psi	kPa	psi	kPa	psi	kPa	psi			
906H	405/70R18	★												
	335/80R18	★	310	45	210	30								
	340/80R18	★	275	40	210	30								
908H	375/75R20	★	275	40	210	30								
914G	17.5R25	★	240	35	210	30					415	60	275	40
924H	17.5R25	★	275	40	210	30					415	60	310	45
	550/65R25	★												
	20.5R25	★	275	40	210	30	325	47	230	33	415	60	275	40
924Hz	17.5R25	★									415	60	310	45
	20.5R25	★	275	40	210	30					415	60	275	40
928Hz	17.5R25	★	345	50	210	30					415	60	310	45
	20.5R25	★	275	40	210	30								
	600/65R25	★	275	40	210	30								
930H	17.5R25	★	345	50	210	30					415	60	310	45
	20.5R25	★	275	40	210	30								
	600/65R25	★	275	40	210	30								
938H	20.5R25	★	345	50	210	30	450	65	305	44	310	45	210	30
	550/65R25	★	380	55	240	35								
	650/65R25	★	275	40	210	30					40	175	25	
950H	23.5R25	★, ★★	310	45	210	30	450	65	305	44	345	50	210	30
	650/65R25	★	380	55	210	30								
	750/65R25	★	345	50	210	30					310	45	175	25
950K	23.5R25	★, ★★	415	60	240	35	475	69	305	44	345	50	210	30
	750/65R25	★	345	50	210	30								
962H	23.5R25	★, ★★	345	50	210	30	475	69	305	44	380	55	240	35
962K	23.5R25	★, ★★	450	65	275	40	475	69	305	44	380	55	240	35
	750/65R25	★	345	50	210	30								
966H	26.5R25	★, ★★	415	60	240	35	450	65	275	40	405	60	275	40
	750/65R25	★	380	55	240	35								
966K	26.5R25	★, ★★	415	60	240	35	475	69	275	44	405	60	275	40
972H	26.5R25	★, ★★	450	65	240	35	475	69	305	44	450	65	275	40
	750/65R25	★	380	55	240	35								
972K	26.5R25	★, ★★	450	65	275	40	475	69	305	44	450	65	275	40
980H	29.5R25	★, ★★	520	75	275	40	475	69	305	44	585	85	380	55
980K	29.5R25	★, ★★	520	75	275	40	525	76	300	47	550	80	380	55
988H	35/65R33	★, ★★	585	85	415	60	630	91	427	62	795	115	525	76
990H	45/65R39	★	585	85	345	50	550	80	350	51	620	90	485	70
992K	45/65R45	★	620	90	415	60								
	45/65R45	★★					655	95	505	73	725	105	485	70
993K	50/65R51	★★	620	90	415	60					725	105	485	70
994F	55/80R57	★	700	102	585	85								
	55.5/80R57	★★									725	105	485	70
	60/80R57	★	700	102	585	85								

NOTE: Bridgestone/Firestone inflation pressure for Giant Loader Tires (992K and above) are in reference to applications without chains. For use with chains please consult your Bridgestone/Firestone representative.

# Tires

## Standard Cold Inflation Pressures

- Log Loaders — Radial Ply
- Integrated Toolcarriers — Radial Ply

*Optimal pressures may vary depending on specific applications and working conditions. Always consult your local tire supplier for operating pressures.*

### LOG LOADERS — Radial Ply

Model	Tire Size	Strength Index	Inflation Pressure											
			Michelin				Goodyear				Bridgestone			
			Front		Rear		Front		Rear		Front		Rear	
kPa	psi	kPa	psi	kPa	psi	kPa	psi	kPa	psi	kPa	psi			
IT14G	15.5R25	★	414	60	276	40	414	60	310	45	345	50	276	40
	17.5R25	★	345	50	207	30	414	60	310	45	345	50	276	40
924H	17.5R25	★	414	60	207	30	427	62	276	40	345	50	276	40
	20.5R25	★	310	45	207	30	324	47	228	33	345	50	276	40
	550/65R25	★	310	45	207	30	324	47	228	33	414	60	310	45
930H	20.5R25	★	379	55	207	30	414	60	310	45	345	50	276	40
	650/65R25	★	310	45	207	30			414	60	310	45		
938H	20.5R25	★	414	60	276	40	448	65	303	44	310	45	207	30
	550/65R25	★	414	60	241	35								
	600/65R25	★												
	650/65R25	★	345	50	207	30								
950H	23.5R25	★, ★★	414	60	276	40	476	69	303	44	345	50	207	30
	650/65R25	★	345	50	241	35								
	750/65R25	★	276	40	207	30								
966H	26.5R25	★, ★★	414	60	276	40	448	65	303	44	414	60	276	40
	750/65R25	★	414	60	276	40								
980H	29.5R25	★, ★★	517	75	276	40	503	73	303	44	586	85	379	55
988H	35/65R33	★, ★★	621	90	414	60	800	116	600	87	655	95	414	60

NOTE: Contact your tire supplier to obtain or confirm proper Log Loader pressures.

### INTEGRATED TOOLCARRIERS — Radial Ply

Model	Tire Size	Strength Index	Inflation Pressure											
			Michelin				Goodyear				Bridgestone			
			Front		Rear		Front		Rear		Front		Rear	
kPa	psi	kPa	psi	kPa	psi	kPa	psi	kPa	psi	kPa	psi			
IT14G	15.5R25	★	276	40	207	30	414	60	310	45	345	50	276	40
	17.5R25	★	241	35	207	30	414	60	310	45	207	30	310	45
924H	17.5R25	★	345	50	207	30	414	60	310	45	345	50	276	40
	20.5R25	★	310	45	207	30	414	60	310	45	345	50	276	40
	550/65R25	★	276	40	207	30			414	60	414	60	310	45
930H	17.5R25	★	345	50	207	30	414	60	310	45	345	50	276	40
	20.5R25	★	276	40	207	30	414	60	310	45	345	50	276	40
	550/65R25	★									414	60	310	45
	600/65R25	★	310	45	207	30								
IT38H	20.5R25	★	276	40	207	30	427	62	276	40	448	65	241	35
IT62H	23.5R25	★	276	40	207	30	427	62	276	40	345	50	207	30

NOTE: Contact your tire supplier to obtain or confirm pressures.

*Optimal pressures may vary depending on specific applications and working conditions. Always consult your local tire supplier for operating pressures.*

**WHEEL DOZERS — Bias Ply**

Model	Tire Size	Ply Rating or Strength Index	Inflation Pressure							
			Goodyear				Bridgestone/Firestone			
			Front		Rear		Front		Rear	
			kPa	psi	kPa	psi	kPa	psi	kPa	psi
814F2	23.5-25	12, 20	248	36	228	33	276	40	276	40
824H	29.5-25	22, 28	248	36	248	36	345	50	345	50
834H	35/65-33	24, 30, 42	324	47	324	47	414	60	414	60
844H	41.25/70-39	34, 42	303	44	303	44	517	75	448	65
854K	45/65-45	58	425	62	275	40				

**WHEEL DOZERS — Radial Ply**

Model	Tire Size	Ply Rating or Strength Index	Inflation Pressure							
			Michelin		Goodyear		Bridgestone			
			Front	Rear	Front	Rear	Front	Rear		
			kPa	psi	kPa	psi	kPa	psi	kPa	psi
814F2	23.5R25	★	310	45	310	45				
	26.5R25	★	276	40	276	40				
824H	29.5R25	★, ★★	276	40	276	40	303	44	303	44
834H	35/65R33	★	379	50	379	50	400	58	400	58
	875/65R33	★★					400	58	400	58
844H	45/65R39	★	379	55	345	50	400	58	400	58
854K	45/65R45	★	483	60	483	60	427	62	427	62
	45/65R45	★★					427	62	483	70



*Optimal pressures may vary depending on specific applications and working conditions. Always consult your local tire supplier for operating pressures.*

**UNDERGROUND MINING — Bias and Radial Ply**

LOAD – HAUL – DUMP		Inflation Pressure														
		Model	Tire Size	Ply Rating or Strength Index	Bridgestone				Michelin				Goodyear			
					Front		Rear		Front		Rear		Front		Rear	
			kPa	psi	kPa	psi	kPa	psi	kPa	psi	kPa	psi	kPa	psi		
<b>R1300G</b>	17.5xR25, VSMS L5S, BR	★★	650	94	480	70	691	100	622	90	552	80	448	65		
	17.5x25, VSDL, BR	★★	650	94	480	70										
	17.5xR25, XMINE D2 MICH	★★														
	17.5x25 20 PLY SMO GY	20														
<b>R1600G</b>	18xR25, VSMS L5S BR	★★	650	94	450	65	691	100	518	75	552	80	448	65		
	18xR25 XMINE D2 L5 MICH	★★														
	18x25, SMO L5S, GY	28														
<b>R1700G</b>	26.5xR25, VSMS L5S, BR	★★	650	94	450	65	622	90	415	60	552	80	448	65		
	26.5x25, VSDL, BR	★★	650	94	450	65										
	26.5xR25, XMINE, D2, MICH	★★														
	26.5x25, 32 PLY, GY	32														
<b>R2900G</b>	29.5x29, 2" VSMS, BR	★★	650	94	450	65	622	90	415	60	690	100	552	80		
	29.5xR29, VSDL L5 BR	★★	650	94	450	65										
	29.5xR29, XMINE, D2, MICH															
	29.5x29, 40 PLY SMO GY	40														
<b>R2900G XTRA</b>	29.5x29 34 PLY, SMO GY	34									690	100	552	80		
	35/65 R33, VSNT, BR	★★	650	94	450	65					690	100	552	80		
	35/65 R33, VSDL, BR	★★	650	94	450	65										
<b>ARTICULATED TRUCKS</b>																
<b>AD30</b>	26.5x25, VSNT, BR	★★	650	94	650	94	415	60	553	80	517	75	448	65		
	26.5x25, VSDL, BR	★★	650	94	650	94										
	26.5xR25, XLDD1A, MICH	★														
	26.5xR25, GP-4D, E4, GY	★★														
<b>AD45B</b>	29.5xR29, VSNT, BR	★★	650	94	650	94	449	65	518	75	517	75	517	75		
	29.5xR29, VSDL, L5, BR	★★	650	94	650	94										
	29.5xR29, XLDD 2A, MICH	★★														
	29.5xR29, 2", RL-5K, GY	★★														
<b>AD55B</b>	35/65 R33, VSNT, BR	★★	650	94	650	94	656	95	656	95	656	95	656	95		
	35/65 R33, VSDL, BR	★★	650	94	650	94										
	35/65 R33, XLDD 2A, MICH	★														
	35/65 R33, XLDD 1A, MICH	★														

**BIAS PLY TIRES**

**RADIAL PLY TIRES**

Tire Size	Weight Increase Per Tire		Mixing Proportions				Weight Increase Per Tire		Mixing Proportions			
	kg	lb	CaCl		Water		kg	lb	CaCl		Water	
			kg	lb	L	gal	kg	lb	kg	lb	L	gal
13.00-24TG	188	414	55	122	132	35	185	407	57	125	128	34
14.00-24TG	215	475	63	140	151	40	256	565	79	173	179	47
15.5-25	192	423	56	125	136	36	224	493	69	151	155	41
16.00-24TG	333	735	98	217	234	62	355	783	109	240	246	65
17.5-25	262	577	77	170	185	49	311	686	95	210	216	57
18.00-25	454	1002	134	296	322	85	502	1107	154	340	348	92
18.4-34	417	919	123	272	295	78	—	—	—	—	—	—
20.5-25	405	892	119	263	284	75	448	987	137	303	310	82
23.1-26	522	1151	154	340	367	97	—	—	—	—	—	—
23.5-25	585	1291	173	382	412	109	633	1396	194	428	439	116
24.5-32	703	1549	207	458	496	131	—	—	—	—	—	—
26.5-25	758	1671	224	494	533	141	841	1853	258	568	583	154
26.5-29	752	1658	222	490	530	140	928	2045	284	627	644	170
28L-26	709	1563	209	462	500	132	—	—	—	—	—	—
29.5-25	970	2139	286	632	685	181	1073	2368	328	723	745	197
29.5-29	1050	2315	310	684	738	195	1190	2623	365	804	825	218
29.5-35	1159	2556	344	758	821	217	1286	2835	394	869	892	236
30.5L-32	874	1928	258	570	617	163	—	—	—	—	—	—
33.25-35	1485	3275	439	968	1048	277	1592	3508	487	1074	1105	292
37.25-35	1712	3775	505	1115	1211	320	2128	4692	653	1439	1476	390
38-39	1870	4123	552	1218	1317	348	—	—	—	—	—	—
35/65-33	1339	2953	396	873	942	249	1430	3152	438	967	992	262
40/65-39	2077	4580	614	1353	1465	387	2194	4836	673	1483	1522	402
41.25/70-39	1897	4183	561	1236	1336	353	—	—	—	—	—	—
45/65-45	2548	5617	753	1659	1794	474	—	—	—	—	—	—

**NOTE:** Ballast weight for bias ply tires from Goodyear data, radial ply weights from Michelin data. Contact your tire supplier for additional information. Under abnormal tire wear conditions, ballasting of rear tires may be desirable. Ballasting of front tires also should only be done where extremely rapid tire wear rates are encountered. Excessive weight will reduce machine performance.

**NOTE:** Fillage beyond 75% of tire enclosed volume is not recommended. With liquid ballasting, inflation pressure must be checked at least once per day.

**NOTE:** 1.6 kg (3½ lb) Calcium Chloride per gallon water. Solution weighs 4.6 kg (10.15 lb) per gallon.

**NOTE:** Total machine mass including all attachments in operating condition, all reservoirs at full capacity and ballasted tires must not exceed certification mass listed on the ROPS certification label.

**NOTE:** Special air to water valves are required for liquid filled tires.



# MINING AND EARTHMOVING

## CONTENTS

Elements of Production .....22-1  
 Volume Measure .....22-2  
 Swell .....22-2  
 Load Factor .....22-2  
 Material Density .....22-2  
 Fill Factor .....22-3  
 Soil Density Tests .....22-3  
 Figuring Production On-the-Job .....22-4  
 Load Weighing .....22-4  
 Time Studies .....22-4  
 English Example .....22-4  
 Metric Example .....22-5  
 Estimating Production Off-the-Job .....22-5  
 Rolling Resistance .....22-5  
 Grade Resistance .....22-6  
 Total Resistance .....22-6  
 Traction .....22-6  
 Altitude .....22-7  
 Job Efficiency .....22-8  
 English Example .....22-8  
 Metric Example .....22-10  
 Systems .....22-13  
 Economic Haul Distances .....22-13  
 Production Estimating .....22-14  
 Loading Match .....22-14  
 Fuel Consumption and Productivity .....22-14  
 Formulas and Rules of Thumb .....22-15

## INTRODUCTION

This section explains the earthmoving principles used to determine machine productivity. It shows how to calculate production on-the-job or estimate production off-the-job.

Machine performance is usually measured on an hourly basis in terms of machine productivity and machine owning and operating cost. Optimum machine performance can be expressed as follows:

$$\text{Lowest cost per ton} = \frac{\text{Lowest Possible Hourly Costs}}{\text{Highest Possible Hourly Productivity}}$$

## ELEMENTS OF PRODUCTION

Production is the hourly rate at which material is moved. Production can be expressed in various units:

### Metric

- Bank Cubic Meters — BCM — bank m<sup>3</sup>
- Loose Cubic Meters — LCM — loose m<sup>3</sup>
- Compacted Cubic Meters — CCM — compacted m<sup>3</sup>
- Tonnes

### English

- Bank Cubic Yards — BCY — bank yd<sup>3</sup>
- Loose Cubic Yards — LCY — loose yd<sup>3</sup>
- Compacted Cubic Yards — CCY — compacted yd<sup>3</sup>
- Tons

For most earthmoving and material handling applications, production is calculated by multiplying the quantity of material (load) moved per cycle by the number of cycles per hour.

$$\text{Production} = \text{Load/cycle} \times \text{cycles/hour}$$

The load can be determined by

- 1) load weighing with scales
- 2) load estimating based on machine rating
- 3) surveyed volume divided by load count
- 4) machine payload measurement system

Generally, earthmoving and overburden removal for coal mines are calculated by volume (bank cubic meters or bank cubic yards). Metal mines and aggregate producers usually work in weight (tons or tonnes).

**Volume Measure** — Material volume is defined according to its state in the earthmoving process. The three measures of volume are:

- BCM (BCY) — one cubic meter (yard) of material as it lies in the natural bank state.
- LCM (LCY) — one cubic meter (yard) of material which has been disturbed and has swelled as a result of movement.
- CCM (CCY) — one cubic meter (yard) of material which has been compacted and has become more dense as a result of compaction.

In order to estimate production, the relationships between bank measure, loose measure, and compacted measure must be known.

**Swell** — Swell is the percentage of original volume (cubic meters or cubic yards) that a material increases when it is removed from the natural state. When excavated, the material breaks up into different size particles that do not fit together, causing air pockets or voids to reduce the weight per volume. For example to hold the same weight of one cubic unit of bank material it takes 30% more volume (1.3 times) after excavation. (Swell is 30%.)

$$1 + \text{Swell} = \frac{\text{Loose cubic volume for a given weight}}{\text{Bank cubic volume for the same given weight}}$$

$$\text{Bank} = \frac{\text{Loose}}{(1 + \text{Swell})}$$

$$\text{Loose} = \text{Bank} \times (1 + \text{Swell})$$

Example Problem:

If a material swells 20%, how many loose cubic meters (loose cubic yards) will it take to move 1000 bank cubic meters (1308 bank cubic yards)?

$$\begin{aligned} \text{Loose} &= \text{Bank} \times (1 + \text{Swell}) = \\ &1000 \text{ BCM} \times (1 + 0.2) = 1200 \text{ LCM} \\ &1308 \text{ BCY} \times (1 + 0.2) = 1570 \text{ LCY} \end{aligned}$$

How many bank cubic meters (yards) were moved if a total of 1000 loose cubic meters (1308 yards) have been moved? Swell is 25%.

$$\begin{aligned} \text{Bank} &= \text{Loose} \div (1 + \text{Swell}) = \\ &1000 \text{ LCM} \div (1 + 0.25) = 800 \text{ BCM} \\ &1308 \text{ LCY} \div (1 + 0.25) = 1046 \text{ BCY} \end{aligned}$$

**Load Factor** — Assume one bank cubic yard of material weighs 3000 lb. Because of material characteristics, this bank cubic yard swells 30% to 1.3 loose cubic yards when loaded, with no change in weight. If this 1.0 bank cubic yard or 1.3 loose cubic yards is compacted, its volume may be reduced to 0.8 compacted cubic yard, and the weight is still 3000 lb.

Instead of dividing by 1 + Swell to determine bank volume, the loose volume can be multiplied by the load factor.

If the percent of material swell is known, the load factor (L.F.) may be obtained by using the following relationship:

$$\text{L.F.} = \frac{100\%}{100\% + \% \text{ swell}}$$

Load factors for various materials are listed in the Tables Section of this handbook.

To estimate the machine payload in bank cubic yards, the volume in loose cubic yards is multiplied by the load factor:

$$\text{Load (BCY)} = \text{Load (LCY)} \times \text{L.F.}$$

The ratio between compacted measure and bank measure is called shrinkage factor (S.F.):

$$\text{S.F.} = \frac{\text{Compacted cubic yards (CCY)}}{\text{Bank cubic yards (BCY)}}$$

Shrinkage factor is either estimated or obtained from job plans or specifications which show the conversion from compacted measure to bank measure. Shrinkage factor should not be confused with percentage compaction (used for specifying embankment density, such as Modified Proctor or California Bearing Ratio [CBR]).

**Material Density** — Density is the weight per unit volume of a material. Materials have various densities depending on particle size, moisture content and variations in the material. The denser the material the more weight there is per unit of equal volume. Density estimates are provided in the Tables Section of this handbook.

$$\text{Density} = \frac{\text{Weight}}{\text{Volume}} = \frac{\text{kg (lb)}}{\text{m}^3 (\text{yd}^3)}$$

$$\text{Weight} = \text{Volume} \times \text{Density}$$

A given material's density changes between bank and loose. One cubic unit of loose material has less weight than one cubic unit of bank material due to air pockets and voids. To correct between bank and loose use the following equations.

$$1 + \text{Swell} = \frac{\text{kg/BCM}}{\text{kg/LCM}} \text{ or } \frac{\text{lb/BCY}}{\text{lb/LCY}}$$

$$\text{lb/LCY} = \frac{\text{lb/BCY}}{(1 + \text{Swell})}$$

$$\text{lb/BCY} = \text{lb/LCY} \times (1 + \text{Swell})$$

**Fill Factor** — The percentage of an available volume in a body, bucket, or bowl that is actually used is expressed as the fill factor. A fill factor of 87% for a hauler body means that 13% of the rated volume is not being used to carry material. Buckets often have fill factors over 100%.

Example Problem:

A 14 cubic yard (heaped 2:1) bucket has a 105% fill factor when operating in a shot sandstone (4125 lb/BCY and a 35% swell).

- What is the loose density of the material?
  - What is the usable volume of the bucket?
  - What is the bucket payload per pass in BCY?
  - What is the bucket payload per pass in tons?
- a)  $\text{lb/LCY} = \text{lb/BCY} \div (1 + \text{Swell}) = 4125 \div (1.35) = 3056 \text{ lb/LCY}$
- b)  $\text{LCY} = \text{rated LCY} \times \text{fill factor} = 14 \times 1.05 = 14.7 \text{ LCY}$
- c)  $\text{lb/pass} = \text{volume} \times \text{density lb/LCY} = 14.7 \times 3056 = 44,923 \text{ lb}$   
 $\text{BCY/pass} = \text{weight} \div \text{density lb/BCY} = 44,923 \div 4125 = 10.9 \text{ BCY}$   
 or bucket LCY from part b  $\div (1 + \text{Swell}) = 14.7 \div 1.35 = 10.9 \text{ BCY}$
- d)  $\text{tons/pass} = \text{lb} \div 2000 \text{ lb/ton} = 44,923 \div 2000 = 22.5 \text{ tons}$

Example Problem:

Construct a 10,000 compacted cubic yard (CCY) bridge approach of dry clay with a shrinkage factor (S.F.) of 0.80. Haul unit is rated 14 loose cubic yards struck and 20 loose cubic yards heaped.

- How many bank yards are needed?
- How many loads are required?

a)  $\text{BCY} = \frac{\text{CCY}}{\text{S.F.}} = \frac{10,000}{0.80} = 12,500 \text{ BCY}$

b)  $\text{Load (BCY)} = \text{Capacity (LCY)} \times \text{Load factor (L.F.)} = 20 \times 0.81 = 16.2 \text{ BCY/Load}$   
 (L.F. of 0.81 from Tables)

$\text{Number of loads required} = \frac{12,500 \text{ BCY}}{16.2 \text{ BCY/Load}} = 772 \text{ Loads}$



**Soil Density Tests** — There are a number of acceptable methods that can be used to determine soil density. Some that are currently in use are:

- Nuclear density moisture gauge
- Sand cone method
- Oil method
- Balloon method
- Cylinder method

All these except the nuclear method use the following procedure:

- Remove a soil sample from bank state.
- Determine the volume of the hole.
- Weigh the soil sample.
- Calculate the bank density kg/BCM (lb/BCY).

The nuclear density moisture gauge is one of the most modern instruments for measuring soil density and moisture. A common radiation channel emits either neutrons or gamma rays into the soil. In determining soil density, the number of gamma rays absorbed and back scattered by soil particles is *indirectly* proportional to the soil density. When measuring moisture content, the number of moderated neutrons reflected back to the detector after colliding with hydrogen particles in the soil is *directly* proportional to the soil's moisture content.

All these methods are satisfactory and will provide accurate densities when performed correctly. Several repetitions are necessary to obtain an average.

**NOTE:** Several newer methods have been successfully applied, along with weigh scales to determine volume and loose density of material moved in hauler bodies. These measurements include photogrammatic and laser scanning technologies.

- Load Weighing
- Time Studies
- Example (English)

**FIGURING PRODUCTION ON-THE-JOB**

**Load Weighing** — The most accurate method of determining the actual load carried is by weighing. This is normally done by weighing the haul unit one wheel or axle at a time with portable scales. Any scales of adequate capacity and accuracy can be used. While weighing, the machine should be level to reduce error caused by weight transfer. Enough loads should be weighed to provide a good average. Machine weight is the sum of the individual wheel or axle weights.

The weight of the load can be determined using the empty and loaded weight of the unit.

Weight of

$$\text{load} = \text{gross machine weight} - \text{empty weight}$$

To determine the bank cubic measure carried by a machine, the load weight is divided by the bank-state density of the material being hauled.

$$\text{BCY} = \frac{\text{Weight of load}}{\text{Bank density}}$$

**Times Studies** — To estimate production, the number of complete trips a unit makes per hour must be determined. First obtain the unit's cycle time with the help of a stop watch. Time several complete cycles to arrive at an average cycle time. By allowing the watch to run continuously, different segments such as load time, wait time, etc. can be recorded for each cycle. Knowing the individual time segments affords a good opportunity to evaluate the balance of the spread and job efficiency. The following is an example of a scraper load time study form. Numbers in the white columns are stop watch readings; numbers in the shaded columns are calculated:

Total Cycle Times (less delays)	Arrive Cut	Wait Time	Begin Load	Load Time	End Load	Begin Delay	Delay Time	End Delay
	0.00	0.30	0.30	0.60	0.90			
3.50	3.50	0.30	3.80	0.65	4.45			
4.00	7.50	0.35	7.85	0.70	8.55	9.95	1.00	10.95
4.00	12.50	0.42	12.92	0.68	13.60			

**NOTE:** All numbers are in minutes

This may be easily extended to include other segments of the cycle such as haul time, dump time, etc. Haul roads may be further segmented to more accurately define performance, including measured speed traps. Similar forms can be made for pushers, loaders, dozers, etc. *Wait Time* is the time a unit must wait for another unit so that the two can function together (haul unit waiting for pusher). *Delay*

*Time* is any time, other than wait time, when a machine is not performing in the work cycle (scraper waiting to cross railroad track).

To determine trips-per-hour at 100% efficiency, divide 60 minutes by the average cycle time less all wait and delay time. Cycle time may or may not include wait and/or delay time. Therefore, it is possible to figure different kinds of production: measured production, production without wait or delay, maximum production, etc. For example:

Actual Production: includes all wait and delay time.

Normal Production (without delays): includes wait time that is considered normal, but no delay time.

Maximum Production: to figure maximum (or optimum) production, both wait time and delay time are eliminated. The cycle time may be further altered by using an optimum load time.

Example (English)

A job study of a Wheel Tractor-Scraper might yield the following information:

- Average wait time = 0.28 minute
- Average load time = 0.65
- Average delay time = 0.25
- Average haul time = 4.26
- Average dump time = 0.50
- Average return time = 2.09
- Average total cycle = 8.03 minutes
- Less wait & delay time = 0.53
- Average cycle 100% eff. = 7.50 minutes

Weight of haul unit empty — 48,650 lb

Weights of haul unit loaded —

Weighing unit #1 — 93,420 lb

Weighing unit #2 — 89,770 lb

Weighing unit #3 — 88,760 lb

271,950 lb;

average = 90,650 lb

1. Average load weight = 90,650 lb – 48,650 lb = 42,000 lb

2. Bank density = 3125 lb/BCY

3. Load =  $\frac{\text{Weight of load}}{\text{Bank density}}$

$$= \frac{42,000 \text{ lb}}{3125 \text{ lb/BCY}} = 13.4 \text{ BCY}$$

4. Cycles/hr =

$$\frac{60 \text{ min/hr}}{\text{Cycle time}} = \frac{60 \text{ min/hr}}{7.50 \text{ min/cycle}} = 80 \text{ cycles/hr}$$

5. Production = Load/cycle × cycles/hr

$$\text{(less delays)} = 13.4 \text{ BCY/cycle} \times 8.0 \text{ cycles/hr} = 107.2 \text{ BCY/hr}$$

Example (Metric)

A job study of a Wheel Tractor-Scraper might yield the following information:

Average wait time	= 0.28 minute
Average load time	= 0.65
Average delay time	= 0.25
Average haul time	= 4.26
Average dump time	= 0.50
Average return time	= 2.09
Average total cycle	= 8.03 minutes
Less wait & delay time	= 0.53
Average cycle 100% eff.	= 7.50 minutes

Weight of haul unit empty — 22 070 kg

Weights of haul unit loaded —

Weighing unit #1	— 42 375 kg
Weighing unit #2	— 40 720 kg
Weighing unit #3	— 40 260 kg

123 355 kg;  
 average = 41 120 kg

1. Average load weight = 41 120 kg – 22 070 kg = 19 050 kg
2. Bank density = 1854 kg/BCM
3. Load =  $\frac{\text{Weight of load}}{\text{Bank density}}$   
 $= \frac{19\,050\text{ kg}}{1854\text{ kg/BCM}} = 10.3\text{ BCM}$
4. Cycles/hr =  $\frac{60\text{ min/hr}}{\text{Cycle time}} = \frac{60\text{ min/hr}}{7.50\text{ min/cycle}} = 80\text{ cycles/hr}$
5. Production = Load/cycle × cycles/hr  
 (less delays) = 10.3 BCM/cycle × 8.0 cycles/hr  
 = 82 BCM/hr



**NOTE:** The Cat Cycle Timer Program software uses laptop computers in place of stopwatches, organizes the data, and allows study results to be printed.

**ESTIMATING PRODUCTION OFF-THE-JOB**

It is often necessary to estimate production of earthmoving machines which will be selected for a job. As a guide, the remainder of the section is devoted to discussions of various factors that may affect production. Some of the figures have been rounded for easier calculation.

**Rolling Resistance (RR)** is a measure of the force that must be overcome to roll or pull a wheel over the ground. It is affected by ground conditions and load — the deeper a wheel sinks into the ground, the higher the rolling resistance. Internal friction and tire flexing also contribute to rolling resistance. Experience has shown that minimum resistance is 1%-1.5% (see Typical Rolling Resistance Factors in Tables section) of the gross machine weight (on tires). A 2% base resistance is quite often used for estimating. Resistance due to tire penetration is approximately 1.5% of the gross machine weight for each inch of tire penetration (0.6% for each cm of tire penetration). Thus rolling resistance can be calculated using these relationships in the following manner:

$$\text{RR} = 2\% \text{ of GMW} + 0.6\% \text{ of GMW per cm tire penetration}$$

$$\text{RR} = 2\% \text{ of GMW} + 1.5\% \text{ of GMW per inch tire penetration}$$

It's *not* necessary for the tires to actually penetrate the road surface for rolling resistance to increase above the minimum. If the road surface flexes under load, the effect is nearly the same — the tire is always running “uphill”. Only on very hard, smooth surfaces with a well compacted base will the rolling resistance approach the minimum.

When actual penetration takes place, some variation in rolling resistance can be noted with various inflation pressures and tread patterns.

**NOTE:** When figuring “pull” requirements for track-type tractors, rolling resistance applies only to the trailed unit's *weight on wheels*. Since tracktype tractors utilize steel wheels moving on steel “roads”, a tractor's rolling resistance is relatively constant and is accounted for in the Drawbar Pull rating.



- Grade Resistance
- Total Resistance
- Traction

**Grade Resistance** is a measure of the force that must be overcome to move a machine over unfavorable grades (uphill). Grade assistance is a measure of the force that assists machine movement on favorable grades (downhill).

Grades are generally measured in percent slope, which is the ratio between vertical rise or fall and the horizontal distance in which the rise or fall occurs. For example, a 1% grade is equivalent to a 1 m (ft) rise or fall for every 100 m (ft) of horizontal distance; a rise of 4.6 m (15 ft) in 53.3 m (175 ft) equals an 8.6% grade.

$$\frac{4.6 \text{ m (rise)}}{53.3 \text{ m (horizontal distance)}} = 8.6\% \text{ grade}$$

$$\frac{15 \text{ ft (rise)}}{175 \text{ ft (horizontal distance)}} = 8.6\% \text{ grade}$$

Uphill grades are normally referred to as adverse grades and downhill grades as favorable grades. Grade resistance is usually expressed as a positive (+) percentage and grade assistance is expressed as a negative (-) percentage.

It has been found that for each 1% increment of adverse grade an additional 10 kg (20 lb) of resistance must be overcome for each metric (U.S.) ton of machine weight. This relationship is the basis for determining the Grade Resistance Factor which is expressed in kg/metric ton (lb/U.S. ton):

$$\begin{aligned} \text{Grade Resistance Factor} &= 10 \text{ kg/m ton} \times \% \text{ grade} \\ &= 20 \text{ lb/U.S. ton} \times \% \text{ grade} \end{aligned}$$

Grade resistance (assistance) is then obtained by multiplying the Grade Resistance Factor by the machine weight (GMW) in metric (U.S.) tons.

$$\text{Grade Resistance} = \text{GR Factor} \times \text{GMW in metric (U.S.) tons}$$

Grade resistance may also be calculated using percentage of gross weight. This method is based on the relationship that grade resistance is approximately equal to 1% of the gross machine weight for 1% of grade.

$$\text{Grade Resistance} = 1\% \text{ of GMW} \times \% \text{ grade}$$

Grade resistance (assistance) affects both wheel and track-type machines.

**Total Resistance** is the combined effect of rolling resistance (wheel vehicles) and grade resistance. It can be computed by summing the values of rolling resistance and grade resistance to give a resistance in kilogram (pounds) force.

$$\text{Total Resistance} = \text{Rolling Resistance} + \text{Grade Resistance}$$

Total resistance can also be represented as consisting completely of grade resistance expressed in percent grade. In other words, the rolling resistance component is viewed as a corresponding quantity of additional adverse grade resistance. Using this approach, total resistance can then be considered in terms of percent grade.

This can be done by converting the contribution of rolling resistance into a corresponding percentage of grade resistance. Since 1% of adverse grade offers a resistance of 10 kg (20 lb) for each metric or (U.S.) ton of machine weight, then each 10 kg (20 lb) of resistance per ton of machine weight can be represented as an additional 1% of adverse grade. Rolling resistance in percent grade and grade resistance in percent grade can then be summed to give Total Resistance in percent or Effective Grade. The following formulas are useful in arriving at Effective Grade.

$$\begin{aligned} \text{Rolling Resistance (\%)} &= 2\% + 0.6\% \text{ per cm tire} \\ &\quad \text{penetration} \\ &= 2\% + 1.5\% \text{ per inch tire} \\ &\quad \text{penetration} \end{aligned}$$

$$\begin{aligned} \text{Grade Resistance (\%)} &= \% \text{ grade} \\ \text{Effective Grade (\%)} &= \text{RR (\%)} + \text{GR (\%)} \end{aligned}$$

Effective grade is a useful concept when working with Rimpull-Speed-Gradeability curves, Retarder curves, Brake Performance curves, and Travel Time curves.

**Traction** — is the driving force developed by a wheel or track as it acts upon a surface. It is expressed as usable Drawbar Pull or Rimpull. The following factors affect traction: weight on the driving wheel or tracks, gripping action of the wheel or track, and ground conditions. The coefficient of traction (for any roadway) is the ratio of the maximum pull developed by the machine to the total weight on the drivers.

$$\text{Coeff. of traction} = \frac{\text{Pull}}{\text{weight on drivers}}$$

Therefore, to find the usable pull for a given machine:

$$\text{Usable pull} = \text{Coeff. of traction} \times \text{weight on drivers}$$

### Example: Track-Type Tractor

What usable drawbar pull (DBP) can a 26 800 kg (59,100 lb) Track-type Tractor exert while working on firm earth? on loose earth? (See table section for coefficient of traction.)

Answer:

Firm earth — Usable DBP =  
 $0.90 \times 26\,800 \text{ kg} = 24\,120 \text{ kg}$   
 $(0.90 \times 59,100 \text{ lb} = 53,190 \text{ lb})$

Loose earth — Usable DBP =  
 $0.60 \times 26\,800 \text{ kg} = 16\,080 \text{ kg}$   
 $(0.60 \times 59,100 \text{ lb} = 35,460 \text{ lb})$

If a load required 21 800 kg (48,000 lb) pull to move it, this tractor could move the load on firm earth. However, if the earth were loose, the tracks would spin.

**NOTE:** D8R through D11R Tractors may attain higher coefficients of traction due to their suspended undercarriage.

Example: Wheel Tractor-Scraper

What usable rimpull can a 621F size machine exert while working on firm earth? on loose earth? The total loaded weight distribution of this unit is:

Drive unit	Scraper unit
wheels: 23 600 kg	wheels: 21 800 kg
(52,000 lb)	(48,000 lb)

Remember, use weight on drivers only.

Answer:

Firm earth —  $0.55 \times 23\,600 \text{ kg} = 12\,980 \text{ kg}$   
 $(0.55 \times 52,000 \text{ lb} = 28,600 \text{ lb})$

Loose earth —  $0.45 \times 23\,600 \text{ kg} = 10\,620 \text{ kg}$   
 $(0.45 \times 52,000 \text{ lb} = 23,400 \text{ lb})$

On firm earth this unit can exert up to 12 980 kg (28,600 lb) rimpull without excessive slipping. However, on loose earth the drivers would slip if more than 10 620 kg (23,400 lb) rimpull were developed.



**Altitude** — Specification sheets show how much pull a machine can produce for a given gear and speed when the engine is operating at rated horsepower. When a standard machine is operated in high altitudes, the engine may require derating to maintain normal engine life. This engine derating will produce less drawbar pull or rimpull.

The Tables Section gives the altitude derating in percent of flywheel horsepower for current machines. It should be noted that some turbocharged engines can operate up to 4570 m (15,000 ft) before they require derating. Most machines are engineered to operate up to 1500-2290 m (5000-7500 ft) before they require derating.

The horsepower derating due to altitude must be considered in any job estimating. The amount of

power deration will be reflected in the machine's gradeability and in the load, travel, and dump and load times (unless loading is independent of the machine itself). Altitude may also reduce retarding performance. Consult a Caterpillar representative to determine if deration is applicable. Fuel grade (heat content) can have a similar effect of derating engine performance.

The example job problem that follows indicates one method of accounting for altitude deration: by increasing the appropriate components of the total cycle time by a percentage equal to the percent of horsepower deration due to altitude. (i.e., if the travel time of a hauling unit is determined to be 1.00 minute at full HP, the time for the same machine derated to 90% of full HP will be 1.10 min.) This is an approximate method that yields reasonably accurate estimates up to 3000 m (10,000 feet) elevation.

Travel time for hauling units derated more than 10% should be calculated as follows using Rimpull-Speed-Gradeability charts.

- 1) Determine total resistance (grade plus rolling) in percent.

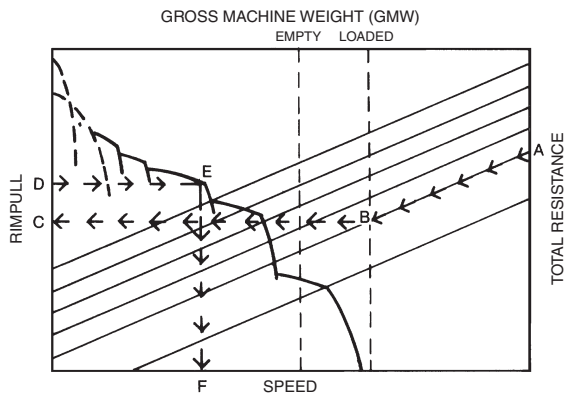

- 2) Beginning at point A on the chart follow the total resistance line diagonally to its intersection, B, with the vertical line corresponding to the appropriate gross machine weight. (Rated loaded and empty GMW lines are shown dotted.)

- 3) Using a straight-edge, establish a horizontal line to the left from point B to point C on the rimpull scale.

- 4) Divide the value of point C as read on the rimpull scale by the percent of total horsepower available after altitude derating from the Tables Section. This yields rimpull value D higher than point C.

- Job Efficiency
- Example Problem (English)

5) Establish a horizontal line right from point D. The farthest right intersection of this line with a curved speed range line is point E.

6) A vertical line down from point E determines point F on the speed scale.

7) Multiply speed in kmh by 16.7 (mph by 88) to obtain speed in m/min (ft/min). Travel time in minutes for a given distance in feet is determined by the formula:

$$\text{Time (min)} = \frac{\text{Distance in m (ft)}}{\text{Speed in m/min (ft/min)}}$$

The *Travel Time Graphs* in sections on Wheel Tractor-Scrapers and Construction & Mining Trucks can be used as an alternative method of calculating haul and/or return times.



The following example provides a method to manually estimate production and cost. Today, computer programs, such as Caterpillar's Fleet Production and Cost Analysis (FPC), provide a much faster and more accurate means to obtain those application results.

Example problem (English)

A contractor is planning to put the following spread on a dam job. What is the estimated production and cost/BCY?

**Equipment:**

- 11 — 631G Wheel Tractor-Scrapers
- 2 — D9T Tractors with C-dozers
- 2 — 12H Motor Graders
- 1 — 825G Tamping Foot Compactor

**Material:**

- Description — Sandy clay; damp, natural bed
- Bank Density — 3000 lb/BCY
- Load Factor — 0.80
- Shrinkage Factor — 0.85
- Traction Factor — 0.50
- Altitude — 7500 ft

**Job Layout — Haul and Return:**

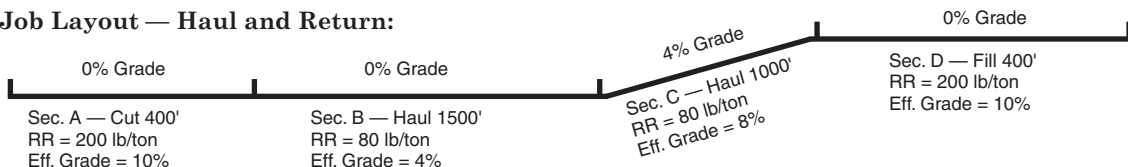

**Total Effective Grade = RR (%) ± GR (%)**

**Sec. A:** Total Effective Grade = 10% + 0% = 10%

**Sec. B:** Total Effective Grade = 4% + 0% = 4%

**Sec. C:** Total Effective Grade = 4% + 4% = 8%

**Sec. D:** Total Effective Grade = 10% + 0% = 10%

**Job Efficiency** is one of the most complex elements of estimating production since it is influenced by factors such as operator skill, minor repairs and adjustments, personnel delays, and delays caused by job layout. An approximation of efficiency, if no job data is available, is given below.

Operation	Working Hour	Efficiency Factor
Day	50 min/hr	0.83
Night	45 min/hr	0.75

These factors do not account for delays due to weather or machine downtime for maintenance and repairs. You must account for such factors based on experience and local conditions.

**1. Estimate Payload:**

Est. load (LCY) × L.F. × Bank Density = payload  
 31 LCY × 0.80 × 3000 lb/BCY = 74,400 lb payload

**2. Establish Machine Weight:**

- Empty Wt. — 102,460 lb or 51.27 tons
- Wt. of Load — 74,400 lb or 37.2 tons
- Total (GMW) — 176,860 lb or 88.4 tons

**3. Calculate Usable Pull (traction limitation):**

*Loaded:* (weight on driving wheels = 54%) (GMW)

Traction Factor × Wt. on driving wheels =  
 0.50 × 176,860 lb × 54% = 47,628 lb

*Empty:* (weight on driving wheels = 69%) (GMW)

Traction Factor × Wt. on driving wheels =  
 0.50 × 102,460 lb × 69% = 35,394 lb

**4. Derate for Altitude:**

Check power available at 7500 ft from altitude deration table in the Tables Section.

- 631G — 100%
- D9T — 100%
- 12H — 83%
- 825G — 100%

Then adjust if necessary:

*Load Time* — controlled by D9T, at 100% power, no change.

*Travel, Maneuver and Spread time* — 631G, no change.

**5. Compare Total Resistance to Tractive Effort on haul:**

*Grade Resistance* —

$$\begin{aligned} \text{GR} &= \text{lb/ton} \times \text{tons} \times \text{adverse grade in percent} \\ \text{Sec. C:} &= 20 \text{ lb/ton} \times 88.4 \text{ tons} \times 4\% \text{ grade} = \\ & \quad 7072 \text{ lb} \end{aligned}$$

*Rolling Resistance* —

$$\begin{aligned} \text{RR} &= \text{RR Factor (lb/ton)} \times \text{GMW (tons)} \\ \text{Sec. A:} &= 200 \text{ lb/ton} \times 88.4 \text{ tons} = 17,686 \text{ lb} \\ \text{Sec. B:} &= 80 \text{ lb/ton} \times 88.4 \text{ tons} = 7072 \text{ lb} \\ \text{Sec. C:} &= 80 \text{ lb/ton} \times 88.4 \text{ tons} = 14,144 \text{ lb} \\ \text{Sec. D:} &= 200 \text{ lb/ton} \times 88.4 \text{ tons} = 17,686 \text{ lb} \end{aligned}$$

*Total Resistance* —

$$\begin{aligned} \text{TR} &= \text{RR} + \text{GR} \\ \text{Sec. A:} &= 17,686 \text{ lb} + 0 = 17,686 \text{ lb} \\ \text{Sec. B:} &= 7072 \text{ lb} + 0 = 7072 \text{ lb} \\ \text{Sec. C:} &= 7072 \text{ lb} + 6496 \text{ lb} = 14,144 \text{ lb} \\ \text{Sec. D:} &= 17,686 \text{ lb} + 0 = 17,686 \text{ lb} \end{aligned}$$

Check usable pounds pull against maximum pounds pull required to move the 631G.

Pull usable ... 47,628 lb loaded

Pull required ... 17,686 lb maximum total resistance

Estimate travel time for haul from 631G (loaded) travel time curve; read travel time from distance and effective grade.

Travel time (from curves):

$$\begin{aligned} \text{Sec. A:} & 0.60 \text{ min} \\ \text{Sec. B:} & 1.00 \\ \text{Sec. C:} & 1.20 \\ \text{Sec. D:} & 0.60 \end{aligned}$$

$$\underline{\quad 3.40 \text{ min}}$$

**NOTE:** This is an estimate only; it does not account for all the acceleration and deceleration time, therefore it is not as accurate as the information obtained from a computer program.

**6. Compare Total Resistance to Tractive Effort on return:**

*Grade Assistance* —

$$\begin{aligned} \text{GA} &= 20 \text{ lb/ton} \times \text{tons} \times \text{negative grade in percent} \\ \text{Sec. C:} &= 20 \text{ lb/ton} \times 51.2 \text{ tons} \times 4\% \text{ grade} = \\ & \quad 4096 \text{ lb} \end{aligned}$$

*Rolling Resistance* —

$$\begin{aligned} \text{RR} &= \text{RR Factor} \times \text{Empty Wt (tons)} \\ \text{Sec. D:} &= 200 \text{ lb/ton} \times 51.2 \text{ tons} = 10,240 \text{ lb} \\ \text{Sec. C:} &= 80 \text{ lb/ton} \times 51.2 \text{ tons} = 4091 \text{ lb} \\ \text{Sec. B:} &= 80 \text{ lb/ton} \times 51.2 \text{ tons} = 4091 \text{ lb} \\ \text{Sec. A:} &= 200 \text{ lb/ton} \times 51.2 \text{ tons} = 10,240 \text{ lb} \end{aligned}$$

*Total Resistance* —

$$\begin{aligned} \text{TR} &= \text{RR} - \text{GA} \\ \text{Sec. D:} &= 10,240 \text{ lb} - 0 = 10,240 \text{ lb} \\ \text{Sec. C:} &= 4096 \text{ lb} - 4096 \text{ lb} = 0 \\ \text{Sec. B:} &= 4096 \text{ lb} - 0 = 4096 \text{ lb} \\ \text{Sec. A:} &= 10,240 \text{ lb} - 0 = 10,240 \text{ lb} \end{aligned}$$

Check usable pounds pull against maximum pounds pull required to move the 631G.

Pounds pull usable ... 35,349 lb empty

Pounds pull required ... 10,240 lb

Estimate travel time for return from 631G empty travel time curve.

Travel time (from curves):

$$\begin{aligned} \text{Sec. D:} & 0.40 \text{ min} \\ \text{Sec. C:} & 0.55 \\ \text{Sec. B:} & 0.80 \\ \text{Sec. A:} & 0.40 \end{aligned}$$

$$\underline{\quad 2.15 \text{ min}}$$

**7. Estimate Cycle Time:**

$$\text{Total Travel Time (Haul plus Return)} = 5.55 \text{ min}$$

$$\text{Adjusted for altitude: } 100\% \times 5.55 \text{ min} = 5.55 \text{ min}$$

$$\text{Load Time} \quad \quad \quad 0.7 \text{ min}$$

$$\text{Maneuver and Spread Time} \quad \quad \quad 0.7 \text{ min}$$

$$\text{Total Cycle Time} \quad \quad \quad \underline{6.95 \text{ min}}$$

**8. Check pusher-scraper combinations:**

Pusher cycle time consists of load, boost, return and maneuver time. Where actual job data is not available, the following may be used.

$$\text{Boost time} = 0.10 \text{ minute}$$

$$\text{Return time} = 40\% \text{ of load time}$$

$$\text{Maneuver time} = 0.15 \text{ minute}$$

$$\text{Pusher cycle time} = 140\% \text{ of load time} + 0.25 \text{ minute}$$

$$\begin{aligned} \text{Pusher cycle time} &= 140\% \text{ of } 0.7 \text{ min} + 0.25 \text{ minute} \\ &= 0.98 + 0.25 = 1.23 \text{ minute} \end{aligned}$$

Scraper cycle time divided by pusher cycle time indicates the number of scrapers which can be handled by each pusher.

$$\frac{6.95 \text{ min}}{1.23 \text{ min}} = 5.65$$

- Example Problem (English)
- Example Problem (Metric)

Each push tractor is capable of handling five plus scrapers. Therefore the two pushers can adequately serve the eleven scrapers.

**9. Estimate Production:**

$$\begin{aligned} \text{Cycles/hour} &= 60 \text{ min} \div \text{Total cycle time} \\ &= 60 \text{ min/hr} \div 6.95 \text{ min/cycle} \\ &= 8.6 \text{ cycles/hr} \end{aligned}$$

$$\begin{aligned} \text{Estimated load} &= \text{Heaped capacity} \times \text{L.F.} \\ &= 31 \text{ LCY} \times 0.80 \\ &= 24.8 \text{ BCY} \end{aligned}$$

$$\begin{aligned} \text{Hourly unit production} &= \text{Est. load} \times \text{cycles/hr} \\ &= 24.8 \text{ BCY} \times 8.6 \text{ cycles/hr} \\ &= 213 \text{ BCY/hr} \end{aligned}$$

$$\begin{aligned} \text{Adjusted production} &= \text{Efficiency factor} \times \text{hourly production} \\ &= 0.83 \text{ (50 min hour)} \times 213 \text{ BCY} \\ &= 177 \text{ BCY/hr} \end{aligned}$$

$$\begin{aligned} \text{Hourly fleet production} &= \text{Unit production} \times \text{No. of units} \\ &= 177 \text{ BCY/hr} \times 11 \\ &= 1947 \text{ BCY/hr} \end{aligned}$$

**10. Estimate Compaction:**

$$\begin{aligned} \text{Compaction requirement} &= \text{S.F.} \times \text{hourly fleet production} \\ &= 0.85 \times 1947 \text{ BCY/hr} \\ &= 1655 \text{ CCY/hr} \end{aligned}$$

Compaction capability (given the following):

- Compacting width, 7.4 ft (W)
- Average compacting speed, 6 mph (S)
- Compacted lift thickness, 7 in (L)
- No. of passes required, 3 (P)

$$\begin{aligned} \text{825G production} &= \\ \text{CCY/hr} &= \frac{W \times S \times L \times 16.3}{P} \quad (\text{conversion constant}) \\ &= \frac{7.4 \times 6 \times 7 \times 16.3}{3} \\ &= 1688 \text{ CCY/hr} \end{aligned}$$

Given the compaction requirement of 1655 CCY/hr, the 825G is an adequate compactor match-up for the rest of the fleet. However, any change to job layout that would increase fleet production would upset this balance.

**11. Estimate Total Hourly Cost:**

631G	@ \$65.00/hr × 11 units	\$715.00
D9T	@ 75.00/hr × 2 units	150.00
12H	@ 15.00/hr × 2 units	30.00
825G	@ 40.00/hr × 1 unit	40.00
Operators	@ 20.00/hr × 16 men	320.00

Total Hourly Owning and Operating Cost	\$1,255.00
--	------------

**12. Calculate Performance:**

$$\begin{aligned} \text{Cost per BCY} &= \frac{\text{Total cost/hr}}{\text{Production/hr}} \\ &= \frac{\$1,255.00}{1947 \text{ BCY/hr}} \\ &= 64\text{¢ BCY} \end{aligned}$$

**NOTE:** Ton-MPH calculations should be made to judge the ability of the tractor-scraper tires to operate safely under these conditions.

**13. Other Considerations:**

If other equipment such as rippers, water wagons, discs or other miscellaneous machines are needed for the particular operation, then these machines must also be included in the cost per BCY.



Example problem (Metric)

A contractor is planning to put the following spread on a dam job. What is the estimated production and cost/BCM?

**Equipment:**

- 11 — 631G Wheel Tractor-Scrapers
- 2 — D9T Tractors with C-dozers
- 2 — 12H Motor Graders
- 1 — 825G Tamping Foot Compactor

**Material:**

- Description — Sandy clay; damp, natural bed
- Bank Density — 1770 kg/BCM
- Load Factor — 0.80
- Shrinkage Factor — 0.85
- Traction Factor — 0.50
- Altitude — 2300 meters

**Job Layout — Haul and Return:**

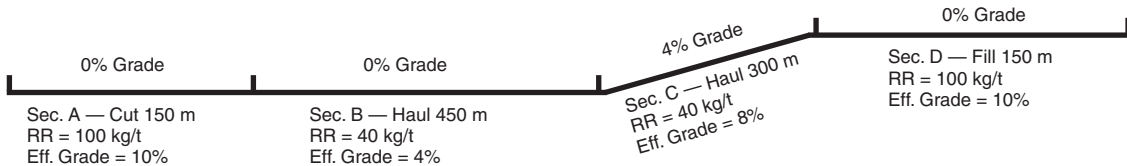

**Total Effective Grade = RR (%) ± GR (%)**

**Sec. A:** Total Effective Grade = 10% + 0% = 10%

**Sec. B:** Total Effective Grade = 4% + 0% = 4%

**Sec. C:** Total Effective Grade = 4% + 4% = 8%

**Sec. D:** Total Effective Grade = 10% + 0% = 10%

**1. Estimate Payload:**

Est. load (LCM) × L.F. × Bank Density = payload

24 LCM × 0.80 × 1770 kg/BCM = 34 000 kg payload

**2. Machine Weight:**

Empty Wt. — 46 475 kg or 46.48 metric tons

Wt. of Load — 34 000 kg or 34 metric tons

Total (GMW) — 80 475 kg or 80.48 metric tons

**3. Calculate Usable Pull (traction limitation):**

*Loaded:* (weight on driving wheels = 54%) (GMW)

Traction Factor × Wt. on driving wheels =

$$0.50 \times 80\,475\text{ kg} \times 54\% = 21\,728\text{ kg}$$

*Empty:* (weight on driving wheels = 69%) (GMW)

Traction Factor × Wt. on driving wheels =

$$0.50 \times 46\,475\text{ kg} \times 69\% = 16\,034\text{ kg}$$

**4. Derate for Altitude:**

Check power available at 2300 m from altitude deration table in the Tables Section.

631G — 100%      12H — 83%

D9T — 100%      825G — 100%

Then adjust if necessary:

*Load Time* — controlled by D9T, at 100% power, no change.

*Travel, Maneuver and Spread time* — 631G, no change.

**5. Compare Total Resistance to Tractive Effort on haul:**

*Grade Resistance* —

GR = 10 kg/metric ton × tons × adverse grade in percent

$$\text{Sec. C:} = 10\text{ kg/metric ton} \times 80.48\text{ metric tons} \times 4\% \text{ grade} = 3219\text{ kg}$$

*Rolling Resistance* —

RR = RR Factor (kg/mton) × GMW (metric tons)

$$\text{Sec. A:} = 100\text{ kg/metric ton} \times 80.48\text{ metric tons} = 8048\text{ kg}$$

$$\text{Sec. B:} = 40\text{ kg/metric ton} \times 80.48\text{ metric tons} = 3219\text{ kg}$$

$$\text{Sec. C:} = 40\text{ kg/metric ton} \times 80.48\text{ metric tons} = 3219\text{ kg}$$

$$\text{Sec. D:} = 100\text{ kg/metric ton} \times 80.48\text{ metric tons} = 8048\text{ kg}$$

*Total Resistance* —

TR = RR + GR

$$\text{Sec. A:} = 8048\text{ kg} + 0 = 8048\text{ kg}$$

$$\text{Sec. B:} = 3219\text{ kg} + 0 = 3219\text{ kg}$$

$$\text{Sec. C:} = 3219\text{ kg} + 3219\text{ kg} = 6438\text{ kg}$$

$$\text{Sec. D:} = 8048\text{ kg} + 0 = 8048\text{ kg}$$

Check usable kilogram force against maximum kilogram force required to move the 631G.

Force usable ... 21 728 kg loaded

Force required ... 8048 kg maximum total resistance

Estimate travel time for haul from 631G (loaded) travel time curve; read travel time from distance and effective grade.

Travel time (from curves):

Sec. A: 0.60 min

Sec. B: 1.00

Sec. C: 1.20

Sec. D: 0.60

$$\underline{\hspace{1.5cm}} \\ 3.40\text{ min}$$

**NOTE:** This is an estimate only; it *does not account for all the acceleration and deceleration time*, therefore it is not as accurate as the information obtained from a computer program.

**6. Compare Total Resistance to Tractive Effort on return:**

*Grade Assistance* —

GA = 10 kg/mton × metric tons × negative grade in percent

$$\text{Sec. C:} = 10\text{ kg/metric ton} \times 46.48\text{ metric tons} \times 4\% \text{ grade} = 1859\text{ kg}$$

*Rolling Resistance —*

RR = RR Factor × Empty Wt.

- Sec. D: = 100 kg/metric ton × 46.48 metric tons  
= 4648 kg
- Sec. C: = 40 kg/metric ton × 46.48 metric tons  
= 1859 kg
- Sec. B: = 40 kg/metric ton × 46.48 metric tons  
= 1859 kg
- Sec. A: = 100 kg/metric ton × 46.48 metric tons  
= 4648 kg

*Total Resistance —*

TR = RR + GA

- Sec. D: = 4648 kg + 0 = 4648 kg
- Sec. C: = 1859 kg + 1859 kg = 0
- Sec. B: = 1859 kg + 0 = 1859 kg
- Sec. A: = 4648 kg + 0 = 4648 kg

Check usable kilogram force against maximum force required to move the 631G.

- Kilogram force usable ... 16 034 kg empty
- Kilogram force required ... 4645 kg

Estimate travel time for return from 631G empty travel time curve.

- Travel time (from curves):
- Sec. D: 0.40 min
- Sec. C: 0.55
- Sec. B: 0.80
- Sec. A: 0.40

2.15 min

**7. Estimate Cycle Time:**

- Total Travel Time (Haul plus Return) = 5.55 min
- Adjusted for altitude: 100% × 5.55 min = 5.55 min
- Load Time 0.7 min
- Maneuver and Spread Time 0.7 min
- Total Cycle Time 6.95 min

**8. Check pusher-scraper combinations:**

Pusher cycle time consists of load, boost, return and maneuver time. Where actual job data is not available, the following may be used.

- Boost time = 0.10 minute
- Return time = 40% of load time
- Maneuver time = 0.15 minute
- Pusher cycle time = 140% of load time + 0.25 minute
- Pusher cycle time = 140% of 0.7 min + 0.25 minute  
= 0.98 + 0.25 = 1.23 minute

Scraper cycle time divided by pusher cycle time indicates the number of scrapers which can be handled by each pusher.

$$\frac{6.95 \text{ min}}{1.23 \text{ min}} = 5.65$$

Each push tractor is capable of handling five plus scrapers. Therefore the two pushers can adequately serve the eleven scrapers.

**9. Estimate Production:**

- Cycles/hour = 60 min ÷ Total cycle time  
= 60 min/hr ÷ 6.95 min/cycle  
= 8.6 cycles/hr

- Estimated load = Heaped capacity × L.F.  
= 24 LCM × 0.80  
= 19.2 BCM

- Hourly unit production = Est. load × cycles/hr  
= 19.2 BCM × 8.6 cycles/hr  
= 165 BCM

- Adjusted production = Efficiency factor × hourly production  
= 0.83 (50 min hour) × 165 BCM  
= 137 BCM/hour

- Hourly fleet production = Unit production × No. of units  
= 137 BCM/hr × 11 units  
= 1507 BCM/hr

**10. Estimate Compaction:**

- Compaction requirement = S.F. × hourly fleet production  
= 0.85 × 1507 BCM/hr  
= 1280 CCM/hr

Compaction capability (given the following):

- Compacting width, 2.26 m (W)
- Average compacting speed, 9.6 km/h (S)
- Compacted lift thickness, 18 cm (L)
- No. of passes required, 3 (P)

825G production =

$$\begin{aligned} \text{CCM/hr} &= \frac{W \times S \times L \times 10}{P} \text{ (conversion factor)} \\ &= \frac{2.26 \times 9.6 \times 18 \times 10}{3} \\ &= 1302 \end{aligned}$$

Given the compaction requirement of 1280 CCM/h, the 825G is an adequate compactor match-up for the rest of the fleet. However, any change to job layout that would increase fleet production would upset this balance.

**11. Estimate Total Hourly Cost:**

631G	@ \$65.00/hr × 11 units	\$715.00
D9T	@ 75.00/hr × 2 units	150.00
12H	@ 15.00/hr × 2 units	30.00
825G	@ 40.00/hr × 1 unit	40.00
Operators	@ 20.00/hr × 16 men	320.00

Total Hourly Owning and  
 Operating Cost \$1,255.00

**12. Calculate Performance:**

$$\begin{aligned} \text{Cost per BCM} &= \frac{\text{Total cost/hr}}{\text{Production/hr}} \\ &= \frac{\$1,255.00}{1507 \text{ BCM/hr}} \\ &= 83¢/\text{BCM} \end{aligned}$$

**NOTE:** Ton-km/h calculations should be made to judge the ability of the tractor-scraper tires to operate safely under these conditions.

**13. Other Considerations:**

If other equipment such as rippers, water wagons, discs or other miscellaneous machines are needed for the particular operation, then these machines must also be included in the cost per BCM.

**SOFTWARE NOTE:** The Cat DOZSIM program can provide a valuable tool for production dozing applications. Motor Grader Calculator can be used to determine the number of graders required to maintain haul roads, given a set of site parameters.

**SYSTEMS**

Caterpillar offers a variety of machines for different applications and jobs. Many of these separate machines function together in mining and earthmoving systems.

- Bulldozing with track-type tractors
- Load-and-Carry with wheel loaders
- Scrapers self-loading, elevator, auger, or push-pull configurations, or push-loaded by track-type tractors
- Articulated trucks loaded by excavators, track loaders or wheel loaders
- Off-highway trucks loaded by shovels, excavators or wheel loaders

**Haul System Selection:** In selecting a hauling system for a project, there may seem to be more than one “right” choice. Many systems may meet the distance, ground conditions, grade, material type, and production rate requirements. After considering all of the different factors, one hauling system usually provides better performance and better potential for lowest cost per ton or BCY/BCM. This makes it critical for the dealer and customer to work together to get accurate information for their operation or project. Caterpillar is committed to providing the correct earthmoving system to match the customer's specific needs.



**GENERAL LOADED HAUL DISTANCES FOR MOBILE SYSTEMS**

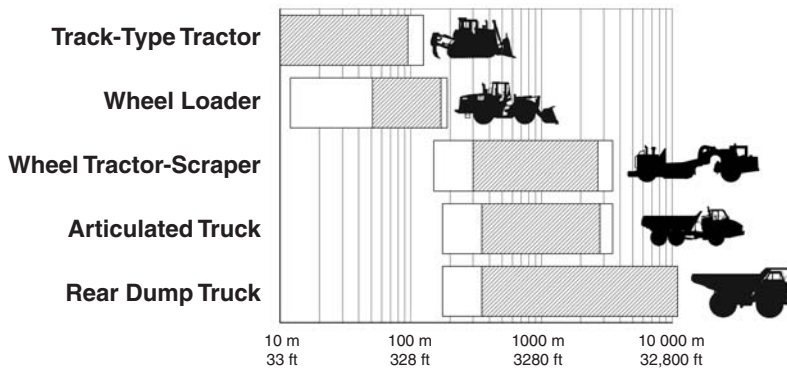

**LOADED HAUL DISTANCE**



**PRODUCTION ESTIMATING**

**Loading Match** — Loading tools have a production range that varies with material, bucket configuration, target size, operator skill and load area conditions. The loader/truck matches given in the following table are with the typical number of passes and production range.

Your Cat dealer can provide advice and estimates based on your specific conditions.

**FUEL CONSUMPTION AND PRODUCTIVITY**

Fuel efficiency is the term used to relate fuel consumption and machine productivity. It is expressed in units of material moved per volume of fuel consumed. Common units are cubic meters or tonnes per liter of fuel (cubic yards or tons/gal). Determining fuel efficiency requires measuring both fuel consumption and production.

Measuring fuel consumption involves tapping into the vehicle’s fuel supply system — without contaminating the fuel. The amount of fuel consumed during operation is then measured on a weight or volumetric basis and correlated with the amount of work the machine has done. Cat machines equipped with VIMS™ system can record fuel consumed with relative accuracy, given the engine is performing close to specifications.

**Cat Earthmoving and Mining Systems  
 Production/50 Min. Hr.**

Tonnes	Tons	Loading Tool	Passes	Target
2270/2450	<b>2500/2700</b>	994F HL	7	793D/F
2450/2700	<b>2700/3000</b>	994F	5	789C
2270/2450	<b>2500/2700</b>	994F HL	6	789C
2450/2700	<b>2700/3000</b>	994F	4	785C/785D
1800/2000	<b>2000/2200</b>	993K HL	6	785C/785D
1800/2000	<b>2000/2200</b>	993K	4	777D/777F
1530/1710	<b>1700/1900</b>	992K	4-5	777D/777F
1180/1360	<b>1300/1500</b>	990H	3-4	773F
800/1000	<b>880/1100</b>	988H	3	770
2720/2900	<b>3000/3200</b>	5230B ME*	7	793D/F
2540/2720	<b>2800/3000</b>	5230B FS*	8	793D/F
2630/2810	<b>2900/3100</b>	5230B ME*	6	789C
2450/2630	<b>2700/2900</b>	5230B FS*	6	789C
2540/2720	<b>2800/3000</b>	5230B ME*	5	785C/785D
2360/2540	<b>2600/2800</b>	5230B FS*	5	785C/785D
1900/2100	<b>2100/2300</b>	5130B ME*	7	785C/785D
1700/1900	<b>1700/2100</b>	5130B FS*	7	785C/785D
1800/2000	<b>2000/2200</b>	5130B ME*	5	777D/777F
1540/1810	<b>1700/2000</b>	5130B FS*	5	777D/777F
910/1090	<b>1000/1200</b>	385 LL ME	7	773F
730/820	<b>800/1000</b>	5090B FS*	7	773F
730/910	<b>800/1000</b>	385 LL ME	5	770
630/820	<b>700/900</b>	5090B FS*	5	770

**Cat Aggregate Systems  
 Production/50 Min. Hr.**

Tonnes	Tons	Loading Tool	Passes	Target
1530/1710	<b>1700/1900</b>	992K	4-5	777D/777F
1450/1630	<b>1600/1800</b>	992K	3	775F
1090/1270	<b>1200/1400</b>	990H	4	775F
910/1180	<b>1000/1300</b>	990H	3-4	773F
700/900	<b>770/990</b>	988H	4-5	773F
800/1000	<b>880/1100</b>	988H	4	772
540/730	<b>600/800</b>	980H HL	6	772
700/900	<b>770/990</b>	988H	3	770
450/630	<b>500/700</b>	980H HL	5	770
1500/1800	<b>1700/2000</b>	5130B FS*	5	777D/777F
1270/1450	<b>1400/1600</b>	5130B FS*	4	775F
1180/1360	<b>1300/1500</b>	5130B FS*	3	773F
630/900	<b>700/900</b>	5090B FS*	7	773F
730/910	<b>800/1000</b>	5090B FS*	5	772
630/820	<b>700/900</b>	5090B FS*	4	770

\*5000 Series Front Shovels and Mass Excavators are no longer produced. This information is included for reference only.

**FORMULAS AND RULES OF THUMB**

$$\begin{aligned} \text{Production, hourly} &= \text{Load (BCM)/cycle} \times \text{cycles/hr} \\ &= \text{Load (BCY)/cycle} \times \text{cycles/hr} \end{aligned}$$

$$\text{Load Factor (L.F.)} = \frac{100\%}{100\% + \% \text{ swell}}$$

$$\begin{aligned} \text{Load (bank measure)} &= \text{Loose cubic meters (LCM)} \times \text{L.F.} \\ &= \text{Loose cubic yards (LCY)} \times \text{L.F.} \\ &\quad \text{Compacted cubic meters (or yards)} \end{aligned}$$

$$\text{Shrinkage Factor (S.F.)} = \frac{\text{Bank cubic meters (or yards)}}{\text{Compacted cubic meters (or yards)}}$$

$$\text{Density} = \text{Weight/Unit Volume}$$

$$\text{Load (bank measure)} = \frac{\text{Weight of load}}{\text{Bank density}}$$

$$\begin{aligned} \text{Rolling Resistance Factor} &= 20 \text{ kg/t} + (6 \text{ kg/t/cm} \times \text{cm}) \\ &= 40 \text{ lb/ton} + (30 \text{ lb/ton/inch} \times \text{inches}) \end{aligned}$$

$$\begin{aligned} \text{Rolling Resistance} &= \text{RR Factor (kg/t)} \times \text{GMW (tons)} \\ &= \text{RR Factor (lb/ton)} \times \text{GMW (tons)} \end{aligned}$$

$$\begin{aligned} \text{Rolling Resistance (general estimation)} &= 2\% \text{ of GMW} + 0.6\% \text{ of GMW per cm tire penetration} \\ &= 2\% \text{ of GMW} + 1.5\% \text{ of GMW per inch tire penetration} \end{aligned}$$

$$\% \text{ Grade} = \frac{\text{vertical change in elevation (rise)}}{\text{corresponding horizontal distance (run)}}$$

$$\begin{aligned} \text{Grade Resistance Factor} &= 10 \text{ kg/m ton} \times \% \text{ grade} \\ &= 20 \text{ lb/ton} \times \% \text{ grade} \end{aligned}$$

$$\begin{aligned} \text{Grade Resistance} &= \text{GR Factor (kg/t)} \times \text{GMW (tons)} \\ &= \text{GR Factor (lb/ton)} \times \text{GMW (tons)} \end{aligned}$$

$$\text{Grade Resistance} = 1\% \text{ of GMW} \times \% \text{ grade}$$

*Total Resistance*

$$= \text{Rolling Resistance (kg or lb)} + \text{Grade Resistance (kg or lb)}$$

$$\text{Total Effective Grade (\%)} = \text{RR (\%)} + \text{GR (\%)}$$

*Usable pull (traction limitation)*

$$\begin{aligned} &= \text{Coeff. of traction} \times \text{weight on drivers} \\ &= \text{Coeff. of traction} \times (\text{Total weight} \times \% \text{ on drivers}) \end{aligned}$$

$$\begin{aligned} \text{Pull required} &= \text{Rolling Resistance} + \text{Grade Resistance} \\ &= \text{Total Resistance} \end{aligned}$$

$$\text{Total Cycle Time} = \text{Fixed time} + \text{Variable time}$$

*Fixed time:* See respective machine production section.

$$\text{Variable time} = \text{Total haul time} + \text{Total return time}$$

$$\begin{aligned} \text{Travel Time} &= \frac{\text{Distance (m)}}{\text{Speed (m/min)}} \\ &= \frac{\text{Distance (ft)}}{\text{Speed (fpm)}} \end{aligned}$$

$$\text{Cycles per hour} = \frac{60 \text{ min/hr}}{\text{Total cycle time (min/cycle)}}$$

$$\text{Adjusted production} = \text{Hourly production} \times \text{Efficiency factor}$$

$$\text{No. of units required} = \frac{\text{Hourly production required}}{\text{Unit hourly production}}$$

$$\text{No. of scrapers a pusher will load} = \frac{\text{Scraper cycle time}}{\text{Pusher cycle time}}$$

$$\text{Pusher cycle time (min)} = 1.40 \text{ Load time (min)} + 0.25 \text{ min}$$

$$\text{Grade Horsepower} = \frac{\text{GMW (kg)} \times \text{Total Effective Grade} \times \text{Speed (km/h)}}{273.75}$$

$$= \frac{\text{GMW (lb)} \times \text{Total Effective Grade} \times \text{Speed (mph)}}{375}$$

Notes —

# STOCKPILE COAL HANDLING

## CONTENTS

Introduction . . . . .	23-1
Machine Selection . . . . .	23-1
How to Equip . . . . .	23-2
Production Factors . . . . .	23-2
Estimating Hourly Production . . . . .	23-3
Track-Type Tractors . . . . .	23-4
Wheel Dozers . . . . .	23-5
Wheel Loaders . . . . .	23-7
Wheel Tractor-Scrapers . . . . .	23-8
Example Problem . . . . .	23-9

## INTRODUCTION

Efficient methods have been developed for handling and storing coal with mobile equipment. Generally, a power plant or other industrial facility which uses coal, meets its daily requirements with incoming coal shipments and will maintain an emergency stockpile or deadpile. The deadpile is designed to meet the burn requirements during any interruption of coal shipments. Interruptions may include inclement weather, carrier strikes, scheduling problems, etc.

The deadpile will contain approximately a 90 day supply of coal and is constructed by thoroughly compacting lifts, or layers, of coal approximately 15 cm (6 in) thick. Thorough compaction of the entire stockpile, including the sides, eliminates air spaces, reducing the possibility of spontaneous combustion.

Reclaiming the deadpiled coal is critical when incoming shipments are not able to satisfy the burn requirements. Four basic types of mobile equipment are available for stockpiling and reclaiming coal — track-type tractors, wheel dozers, wheel loaders, and wheel tractor-scrappers. Each type has its own specific advantages. The equipment selected must be able to meet the maximum hourly burn rate.

## MACHINE SELECTION

### Track-Type Tractors

Track-type tractors continue to be the most widely used machines for coal handling operations. Equipped with a U-shaped coal dozer, they are suitable for meeting high production requirements over dozing distances of less than 152 m (500 ft). Their tractive capabilities and gradeability permit them to

operate on the sides of the stockpile and surge pile which often prove inaccessible to other types of equipment. They can also remove snow and frost penetrated coal from the stockpile surface so that rubber-tired equipment can work efficiently.

### Wheel Dozers

These machines, with their long wheel base, low center of gravity, and articulated design, offer good stability and maneuverability. They have the ability to travel at a higher speed than the track-type tractor, moving easily from one area of operation to another, and provide greater compactive effort with fewer passes. They are capable of performing some utility functions. However, their coefficient of traction is less than that of track-type tractors. The most efficient dozing distance for the wheel dozers is usually less than 152 m (500 ft).

Coal scoops are also available for wheel dozers and may improve production under certain operating conditions.

### Wheel Loaders

As dozing and hauling distances increase, wheel loaders are able to effectively move coal in load-and-carry operations. Since coal is a relatively light material, the loaders should be equipped with larger buckets sized for coal density. Versatility and mobility allow them to perform a variety of tasks, both on and off the stockpile. They can load trucks or railcars, dig out bottom ash and boiler slag from the ash storage areas, and move railcars within the vicinity of the power plant. Generally wheel loaders are more efficient than track or wheel dozers at distances of 122 m (400 ft) or more.

### Coal Bowl Wheel Tractor-Scrapers

Coal Bowl Wheel Tractor-Scrapers are typically used for building and maintaining coal stockpiles and hauling coal to the supply system at coal power plants. The self-loading capability, large capacity, coal pile compaction, and high speed of Coal Bowl Wheel Tractor-Scrapers make them the tool of choice for moving coal both short and long distances. Coal Bowl Wheel Tractor-Scrapers are available in the 637G and 657G tandem engine models. Please reference section 8 of this handbook for more information on Coal Bowl Wheel Tractor-Scrapers.

**HOW TO EQUIP**

**Counterweighting**

While larger blades or buckets allow for greater production, counterweighting is often necessary to improve the machine's balance and handling capability. For track-type tractors, a rear counterweight is recommended. Wheel machines use various methods to add weight. For example, scoop dozers use front counterweights, and wheel machines often use tire ballast. Below is a weight comparison of the Cat standard U-blade to the Coal Dozer, along with the recommended counterweight for D11T, D10T, D9T, D8T, and 834H.

**COAL STOCKPILE BLADE WEIGHT COMPARISON/  
COUNTERWEIGHTING**

Model	U-Blade		Coal Dozer/ Scoop		Counterweight	
	kg	lb	kg	lb	kg	lb
D11T	11 608	<b>25,590</b>	11 340	<b>25,000</b>	4989	<b>11,000</b>
D10T	6188	<b>13,643</b>	6440	<b>14,200</b>	2928	<b>6456</b>
D9T	4179	<b>9214</b>	4490	<b>9900</b>	3142	<b>6926</b>
D8T	2825	<b>6228</b>	3200	<b>7050</b>	2749	<b>6060</b>
834H	2994	<b>6600</b>	3630	<b>8000</b>	75% CaCl <sub>2</sub> in all tires —	
*834H with Scoop			8700	<b>19,180</b>	5360	<b>11,816</b>

Weights include blade or scoop only. The change in machine weight is determined by adding or subtracting the difference between the two blades. Counterweight or ballast may also need to be considered.

**Track Shoe Width**

Track shoes are an important consideration since shoe width determines tractive capability and compaction. Depending on the coal being stockpiled, the utility company will often have a strong preference concerning track shoe width. Basically, utilities stockpiling low rank or sub-bituminous rank lignite coal usually prefer the standard shoe width for maximum compactive effort to reduce the possibility of spontaneous combustion.

Utilities burning medium or high rank bituminous coals are not as concerned with spontaneous combustion and sometimes prefer a wider shoe that allows increased tractive capability on loose or less densely compacted coal stockpiles.

**Tires**

Many utility companies have established a tire preference for wheel machines. Normally a radial tire allows for the maximum tire print in the stockpile surface providing the best traction.

Tire pressure may be of equal importance to tire selection. Tests with hydro-inflated (liquid ballasting) tires indicate that inflation pressure of approximately 275 kPa (40 psi) improves machine performance over higher inflation pressure. Lower than 275 kPa (40 psi) is not recommended for hydro-inflated tires. (For more hydro-inflation information see the Tire section.)

**Other**

The 834H's performance may be improved in the varying underfoot conditions of a coal stockpile with the use of a Detroit NoSPIN differential. This differential provides added tractive capability on all coal piles, particularly loose coal.

**PRODUCTION FACTORS**

1. *The effect of grade* — dozer production will increase 3% for each 1% of favorable grade and decrease 2% for each 1% of adverse grade up to grades of 10%. The graph below exemplifies this point.

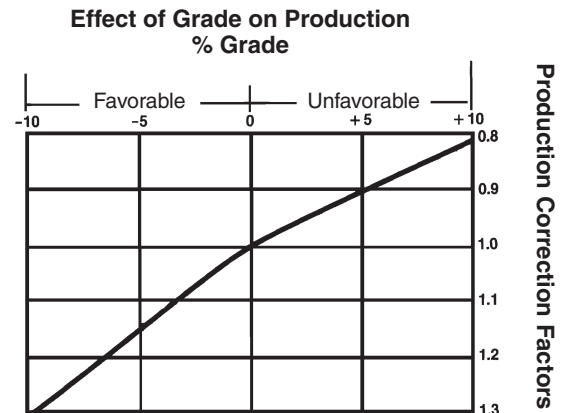

As a rule of thumb, track-type tractors can negotiate grades of about 60% in loose coal. Wheel dozers can negotiate grades up to 25% on fairly well compacted coal.

2. *Slot dozing*, which consists of dozing repeatedly in the same tracks, will increase production. The deeper the slot, the greater the increase in production. Obviously this will disrupt the surface of the pile; however it does provide maximum production.

Slot Condition	Slot Depth	Increase in Production
Slight	60 cm ~ <b>2 ft</b>	10%
Consistent	60 cm-1.5 m ~ <b>2-5 ft</b>	25%
Very Consistent	Over 1.5 m ~ <b>Over 5 ft</b>	30% +

3. *Relative traction* — machines will provide greater tractive effort as the compaction beneath them increases.

Condition	Machine	Coefficient of Traction
Well Compacted Coal	Track-type	*0.75-0.80
	Wheel	0.40-0.50
Loose Coal	Track-type	*0.60
	Wheel	0.30-0.40

\*D11T, D10T, D9T and D8T will often achieve a higher coefficient of traction due to their suspended undercarriage.

4. *Rolling Resistance* of rubber tired equipment will decrease as the compaction of the coal beneath the machines increases. Here are total rolling resistances on various surfaces.

	kg/Metric Ton	lb/U.S. Ton
● Main travel area from loading area to stockpile traveled and maintained.	29	65
● Travel over the compacted deadpile.	36	80
● Travel over thin lifts of uncompacted coal on the deadpile.	54	120
● Travel on loose piles under stacking conveyor or on a windrow.	90-136	200-300

5. *The degree of compaction required* — for medium and high rank bituminous coal, track-type tractors will normally provide ample compaction to prevent fires. For low rank coals, such as sub-bituminous and lignite, rubber tired machines, pneumatic compactors or sealing may be required to prevent fires. The following table illustrates the compaction that is possible if the coal is spread in thin lifts and the machine makes a sufficient number of passes over the entire lift surface.

Machine	kg/m <sup>3</sup>	lb/ft <sup>3</sup>	lb/yd <sup>3</sup>
Track-Type Tractors	960-1160	<b>60-72</b>	<b>1620-1950</b>
Wheel Dozers	1040-1200	<b>65-75</b>	<b>1750-2030</b>
Wheel Loaders	1040-1250	<b>65-78</b>	<b>1750-2110</b>
Wheel Tractor-Scrapers	1100-1280	<b>68-80</b>	<b>1840-2160</b>

### ESTIMATING HOURLY PRODUCTION

The following graphs may be used for estimating the hourly production of machines handling mixed bituminous coal. The graphs are based on 100% machine efficiency under normal job conditions and average operator; they do not take into account adverse grades, downtime, wait time, poor traction, etc. These production estimates should be evaluated in light of individual job conditions and efficiency. Moreover, a job efficiency correction factor should be applied to the production estimate shown when using these graphs.

To estimate travel times for a specific machine refer to the performance graphs or charts in the appropriate model section of this book.

**NOTE:** Capacities and production curves on the next pages are based on bituminous coal with a density of 890 kg/m<sup>3</sup> or 1500 lb/yd<sup>3</sup> or 55 lb/ft<sup>3</sup>. For sub-bituminous coal with a density of 800 kg/m<sup>3</sup> or 1350 lb/yd<sup>3</sup> or 50 lb/ft<sup>3</sup> multiply tonnage figure by 0.90. For lignite with an average density of 710 kg/m<sup>3</sup> or 1200 lb/yd<sup>3</sup> or 45 lb/ft<sup>3</sup> multiply tonnage figure by 0.80.

**Track-Type Tractors Estimated Production with U-Blade (Coal Dozer)**

**Factors:**

- Mixed Bituminous Coal
- Storage and Reclamation
- 0% Grade
- 0.80 Coefficient of Traction

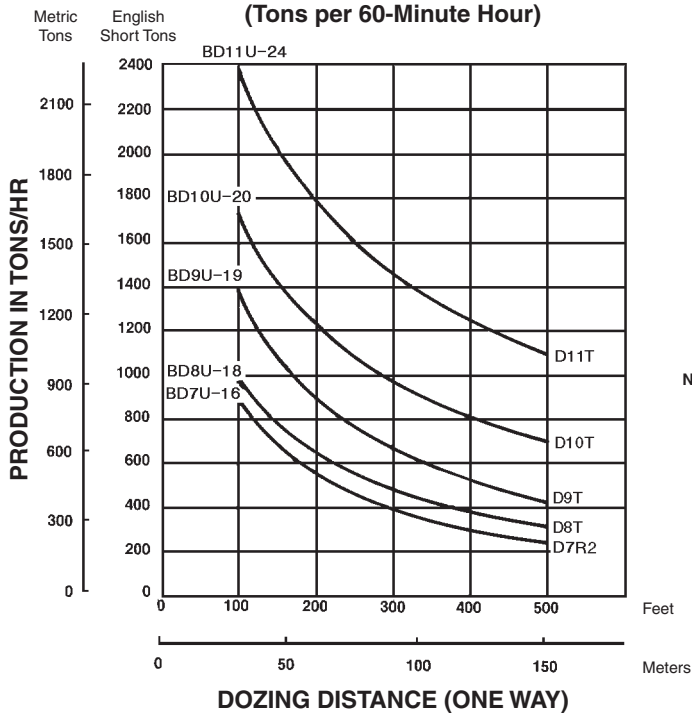

**NOTE:** This chart is based on numerous field studies made under varying job conditions. Refer to correction factors following these charts.

Tractor	U-Blade			Blade Capacities			
	Model	m	ft	Metric tons	U.S. tons	m <sup>3</sup>	yd <sup>3</sup>
D11T	BD11U-24	7.32	24'	66.7	73.5	74.9	98.0
D10T	BD10U-20	6.10	20'	40.85	45.0	45.9	60.0
D9T	BD9U-19	5.79	19'	32.6	35.9	37.0	48.0
D8T	BD8U-18	5.49	18'	19.0	21.0	21.4	28.0
D7R2	BD7U-16	4.88	16'	14.28	15.75	16.05	21.0
D6R	BD6U	4.27	14'	8.84	9.75	9.9	13.0

Refer to Track-Type Tractor/Bulldozer section for additional special attachment specifications.

**Wheel Dozers Estimated Production with U-Blade (Coal Dozer)**

**NOTE:** This chart is based on numerous field studies made under varying job conditions. Refer to correction factors following these charts.

**Factors:**

- Mixed Bituminous Coal
- Storage and Reclamation
- 0% Grade
- 0.80 Coefficient of Traction

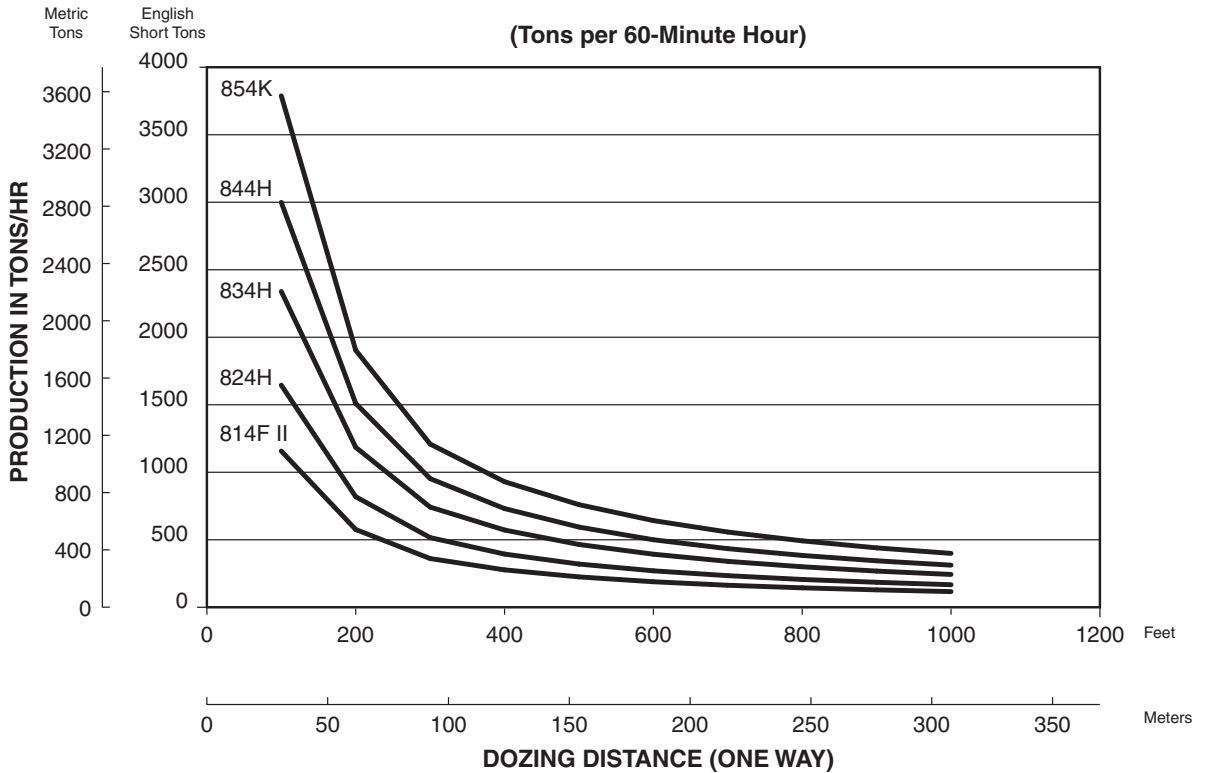

Tractor	U-Blade			Blade Capacities			
	Model	m	ft	Metric tons	U.S. tons	m <sup>3</sup>	yd <sup>3</sup>
854K	153-2113	7.20	23'8"	38.19	42.26	44.7	58.2
844H	153-2111	5.84	19'2"	26.23	29.02	30.7	40.2
834H	BD834U-20	6.17	20'3"	18.80	20.80	22.0	29.0
824H	BD824U-15	4.79	15'9"	14.20	15.70	16.1	21.0
814F II	BD814U-14	4.32	14'2"	9.40	10.30	11.0	14.0

**NOTE:** Blade capacities in tons figured using weight of coal at 890 kg/m<sup>3</sup> (1500 lb/yd<sup>3</sup>).

Refer to Track-Type Tractor/Bulldozer section for additional special attachment specifications.



**Wheel Dozers Estimated Production with Coal Scoop**

**Factors:**

- Mixed Bituminous Coal
- Storage and Reclamation
- 0% Grade
- 0.80 Coefficient of Traction

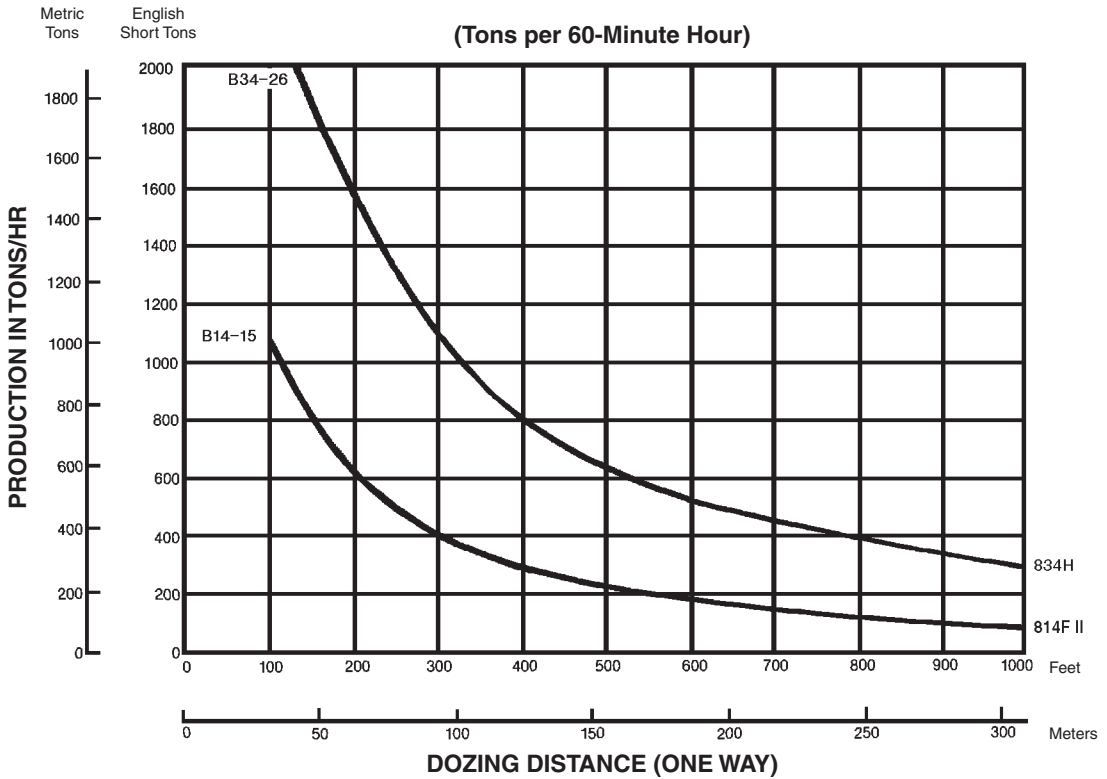

Tractor	Coal Scoop		Scoop Capacities (Lift and Carry)				Doze Capacities				
	Model	m	ft	Metric tons	U.S. tons	m <sup>3</sup>	yd <sup>3</sup>	Metric tons	U.S. tons	m <sup>3</sup>	yd <sup>3</sup>
834H	B34-26	5.3	17'4"	18.3	20.2	19.9	26	37.5	41.25	37.5	49
814F II	B14-15	3.7	12'3"	8.2	9.0	11.5	15	16.3	18.0	19.1	25

Refer to Track-Type Tractor/Bulldozer section for additional special attachment specifications.

**Wheel Loaders Estimated Production  
with Coal Bucket**

**Factors:**

- Mixed Bituminous Coal
- Storage and Reclamation
- 0% Grade
- 0.80 Coefficient of Traction

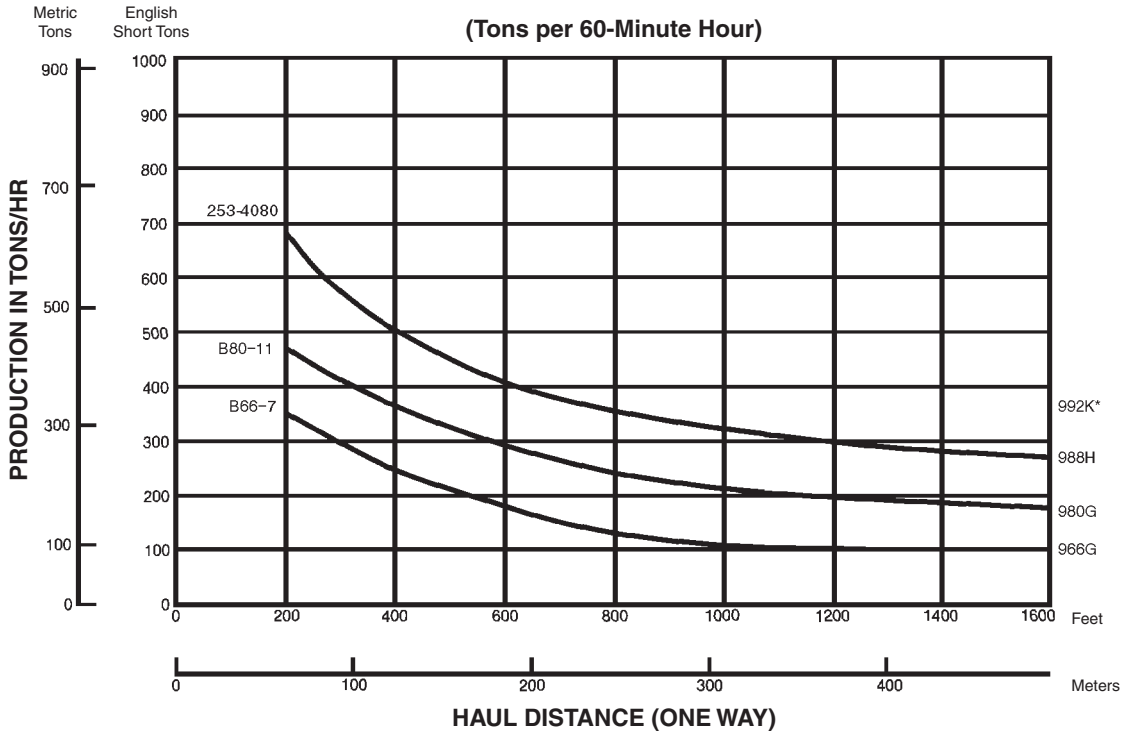

Loader	Coal Bucket	Bucket Capacities			
	Model	Metric tons	U.S. tons	m <sup>3</sup>	yd <sup>3</sup>
992K	294-9020	16.83	<b>18.61</b>	19.11	<b>25.00</b>
	275-9590	20.19	<b>22.33</b>	22.93	<b>30.00</b>
988H	253-4080	11.44	<b>12.65</b>	12.99	<b>17.00</b>
980G	B80-11	7.30	<b>8.10</b>	8.20	<b>10.75</b>
966G	B66-7	4.80	<b>5.30</b>	5.50	<b>7.25</b>

\*Information unavailable at time of printing.

**NOTE:** Bucket capacities include bottom cutting edge in tons figured using weight of coal at 890 kg/m<sup>3</sup> (1500 lb/yd<sup>3</sup>).

Wheel Tractor-Scrapers Estimated Production

Factors:

- Mixed Bituminous Coal
- Storage and Reclamation
- 0% Grade
- 0.50 Coefficient of Traction

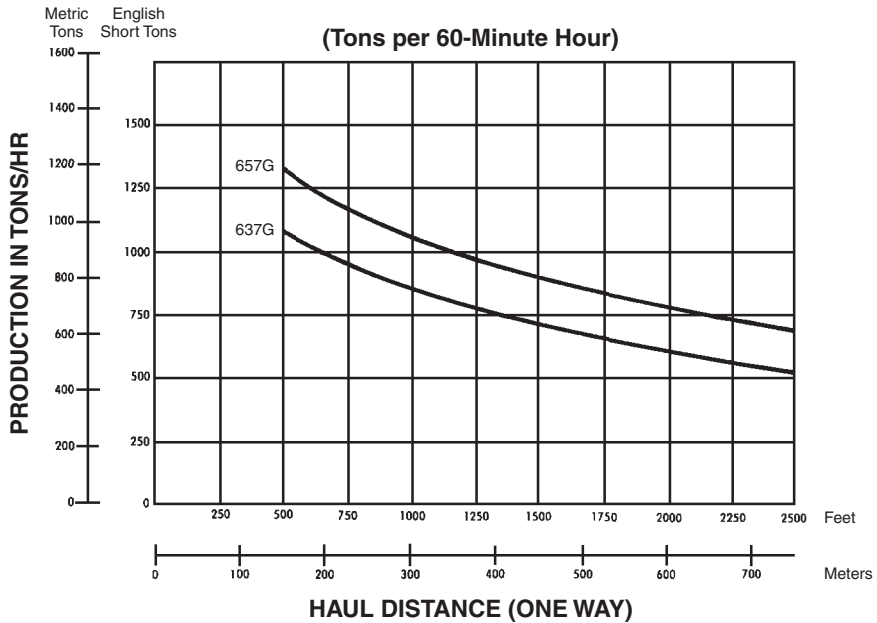

Coal Scraper	Bowl Capacities					
	Metric tons	U.S. tons	Struck		Heaped	
			m <sup>3</sup>	yd <sup>3</sup>	m <sup>3</sup>	yd <sup>3</sup>
657G	49.9	55	45	59	56	73
637G	34.5	38	31	41	38	50

Average fixed time to load, maneuver and dump:  
 657G — 1.12 min.  
 637G — 1.10 min.

**NOTE:**

- The 657G Coal Scraper is 1072 mm (42.2") longer, the bowl sides are 1010 mm (39.8") taller, the apron is 677 mm (26.7") taller, and the ejector is 944 mm (37.2") taller than its earthmoving counterpart.
- The 637G Coal Scraper is 736 mm (29.0") longer, the bowl sides are 476 mm (18.7") taller, and the apron is 499 mm (19.6") taller than its earthmoving counterpart.
- The rimpull, travel times, and retarder performance for the coal scrapers are the same as for the standard machines. See Wheel Tractor-Scrapers section for charts and graphs.

Example Problem

A coal-fired utility company has a coal requirement of approximately 315 metric tons (350 tons) per hour. Specify the coal handling machine that will satisfy this demand.

Conditions:

Lignite Coal 710 kg/m<sup>3</sup> (1200 lb/yd<sup>3</sup>)

90 m (300 ft) push distance

5% adverse grade

50 minute hour operation efficiency

Solution:

Calculate the D9T's production equipped with the BD9U-19 Coal U-Blade by using the D9T production curve. Start at 90 m (300 ft) and read up to the D9T production line, then over to the left to determine its maximum hourly production of 612 metric tons (675 tons).

Since the graphs are based on a 890 kg/m<sup>3</sup> (1500 lb/yd<sup>3</sup>) coal density, this production figure has to be adjusted to reflect lignite coal:

Coal density correction factor = 710/890 (1200/1500) = 0.8.

Obtain the production correction factor for the 5% adverse grade from the chart: 0.9.

The correction factor for the 50 minute hour is 50/60 = 0.83.

Now calculate the adjusted D9T hourly production using the correction factors:

Metric  $612 \times .8 \times .9 \times .83 = 366$  tons/hour

English  $675 \times .8 \times .9 \times .83 = 403$  tons/hour

The D9T falls in the required production range. For short periods of peak power capacity, production could be increased by slot dozing.

Production for the D10T, 824H and 834H can be calculated using the same method.

**D10T**

Metric  $850 \times .8 \times .9 \times .83 = 508$  tons/hour

English  $935 \times .8 \times .9 \times .83 = 559$  tons/hour

**824H**

Metric  $400 \times .8 \times .9 \times .83 = 239$  tons/hour

English  $440 \times .8 \times .9 \times .83 = 263$  tons/hour

**834H**

Metric  $689 \times .8 \times .9 \times .83 = 412$  tons/hour

English  $760 \times .8 \times .9 \times .83 = 454$  tons/hour

Therefore, the D9T or 834H could most economically satisfy the production requirements.



# LAND CLEARING

## CONTENTS

Variables Affecting Clearing Operations . . . .	.24-1
Job Surveys . . . . .	.24-2
Clearing Methods and Equipment . . . . .	.24-2
Equipment Selection Table . . . . .	.24-3
Production Estimating:	
General . . . . .	.24-4
Cutting . . . . .	.24-5
Piling . . . . .	.24-6
Work Tools . . . . .	.24-8

Land clearing must be treated more as an art than a science because production rates and methods vary greatly from one area to another. This section deals with the many variables in clearing and includes methods, equipment and procedures to determine productivity rates.

## VARIABLES AFFECTING CLEARING OPERATIONS

*Vegetative Growth* — Factors affecting production and therefore cost, include the number of trees, size of trees, wood density, root systems, vines and undergrowth. These factors can be estimated by a “tree-count” as discussed under “Job Survey.”

*End Use of Land* — Since different end uses require different degrees of clearing (i.e. highways, dams, tree crops, row crops, etc.), this is one of the most important factors to consider in choosing the proper clearing method and equipment.

*Soil Conditions or Bearing Capacity* — Factors affecting clearing operations include topsoil depth, soil type, moisture content, and the presence of rocks and stones.

*Topography* — Grade and terrain factors such as steep slopes, ditches, swampy areas, boulders and even ant hills greatly affect the normal operation of some equipment.

*Rainfall and Climate* — Usually all phases of land clearing from cutting to burning are concerned to some degree with temperature changes and the amount of rainfall during the clearing operation.

*Job Specifications* — Specifications dictate the degree of clearing to be done, area size, completion dates, method of debris disposal, soil conservation and other factors which affect method and equipment selection.

**JOB SURVEYS**

Knowledge of rainfall and climate, end use of the land, and job specifications can be obtained from records, surveys, engineering studies, and written specifications. You should personally review the land to be cleared to gain other necessary and valuable information.

The survey should include a study of general topography and soil conditions. Note such problem factors as hills, rocks, or swamps which would significantly affect production or which would require special treatment.

Cruise the area to be cleared and determine the acreage of each vegetative type (i.e. upland woods, low timberlands, swamps). Make at least three tree counts at random for each vegetation type. To conduct these counts, randomly locate two points 100 meters (328 feet) apart. Count and measure vegetative growth along a straight line between these points for a width of about 5 meters (16 feet) on both sides. This gives the population of 1/10 hectare (1/4 acre).

1. Density of vegetation less than 30 cm (12 in) diameter
  - Dense — 1480 trees/hectare or more (600 trees/acre)
  - Medium — 990-1480 trees/hectare (400-600 trees/acre)
  - Light — less than 990 trees/hectare (400 trees/acre)
2. Presence of hardwoods expressed in percent
3. Presence of heavy vines
4. Average number of trees per hectare (2.47 acres) in each of the following ground level diameter size ranges:
  - Less than 30 cm (1 ft)
  - 31 cm-60 cm (1-2 ft)
  - 61 cm-90 cm (2-3 ft)
  - 91 cm-120 cm (3-4 ft)
  - 121 cm-180 cm (4-6 ft)
5. Sum of diameter of all trees per hectare (2.47 acres) above 180 cm (6 ft) in diameter at ground level.

**CLEARING METHODS AND EQUIPMENT**

*Methods for Initial Felling* — There are several methods indicating the degree of clearing for initial felling and several types of equipment for use with each method. Equipment use in different size vegetation and different size areas is summarized in the table on the next page. This information should serve only as a rough guideline in selecting equipment. The economical land area for each type of equipment will vary with the capital cost of equipment and moving cost. It is also affected by whether there are alternate uses for equipment such as using tractors for other construction work or tillage.

*Land Clearing Machines* — Job size, severity of job such as tree size, and time limit to complete will influence machine selection. Some machines, such as the D6T, D7R Series 2 and D8T are more suited for this type work than others, but imagination and resourcefulness can allow the use of other types of machines in specific applications. For example, loaders are used more today in raking and piling operations than ever before.

*Operator Protection and Machine Guarding* — Daily production has been estimated to increase 20% when cab guards are used. Cabs designed specifically for clearing are available from Rome and other auxiliary equipment manufacturers.

The radiator, engine, and underside of the tractor must be well protected. Perforated hoods, screens, crankcase guards and hydraulic cylinder guards are generally recommended.

Generally speaking, lower cost clearing can be done with larger tractors if the amount of clearing involved is sufficient to merit the initial investment in the bigger machine. Because most clearing work requires frequent direction changes, a power shift transmission should be standard equipment. The direct drive transmission tractor is recommended when the tractor is used principally in constant drawbar work such as chaining or pulling a disc harrow. In most applications, a winch should also be considered on one of every three tractors in a fleet.

## EQUIPMENT SELECTION TABLE

	UPROOTING	CUTTING AT OR ABOVE GROUND LEVEL	KNOCKING TO THE GROUND	INCORPORATING INTO THE SOIL
<b>LIGHT CLEARING — Vegetation up to 5 cm (2 in) diameter</b>				
Small areas 4 hectares (10 acres)	Bulldozer blade	Wheel-mounted circular saws	Bulldozer blade	Moldboard plows, disc plows, disc harrows
Medium areas 40 hectares (100 acres)	Bulldozer blade	Heavy duty sickle mowers [up to 3.7 cm (1½ in) diameter] tractor-mounted circular saws, suspended rotary mowers	Bulldozer blade, rotary mowers; flail-type rotary cutters; rolling brush cutters	Moldboard plows; disc plows, disc harrows
Large areas 400 hectares (1000 acres)	Bulldozer blade, root rake, grubber, root plow, anchor chain drawn between two crawler tractors; rails	—	Rolling brush cutter; flail- type cutter; anchor chain drawn between two crawler tractors; rails	Undercutter with disc; moldboard plows; disc plows; disc harrows
<b>INTERMEDIATE CLEARING — Vegetation 5 to 20 cm (2 to 8 in) diameter</b>				
Small areas 4 hectares (10 acres)	Bulldozer blade	Wheel-mounted circular saws	Bulldozer blade	Heavy-duty disc plow; disc harrow
Medium areas 40 hectares (100 acres)	Bulldozer blade	Tractor-mounted circular saws, single scissor type tree shears	Bulldozer blade, rolling brush cutter [up to 12 cm (5 in) diameter], rotary mower [up to 10 cm (4 in) diameter]	Heavy-duty disc plow; disc harrow
Large areas 400 hectares (1000 acres)	Shearing blade, angling (tilted) bulldozer blade, rakes, anchor chain drawn between two crawler tractors, root plow	Shearing blade (angling or V-type)	Bulldozer blade, flail-type rotary cutter, anchor chain	Bulldozer blade with duty harrow
<b>LARGE CLEARING — Vegetation 20 cm (8 in) diameter or larger</b>				
Small areas 4 hectares (10 acres)	Bulldozer blade	—	Bulldozer blade	—
Medium areas 40 hectares (100 acres)	Shearing blade, angling (tilted), knockdown beam, rakes, tree stumper	Shearing blade (angling or V-type), tree shear [up to 70 cm (26 in) softwood; 35 cm (14 in) hardwood], shearing blade — power saw combination	Bulldozer blade	—
Large areas 400 hectares (1000 acres)	Shearing blade, angling (tilted), tree pusher, rakes, tree stumper, anchor chain with ball drawn between two crawler tractors	Shearing blade (angling or V-type), shearing blade — power saw combination	Anchor chain with ball drawn between two crawler tractors. [Use dozer blade for trees over 18 cm (7 in).]	—

**NOTE:** The most economical size area for each type of equipment will vary with the relative cost of capital equipment versus labor. It is also affected by whether there are alternate uses for equipment such as using tractors for tillage.



**PRODUCTION ESTIMATING**

**GENERAL — CONSTANT SPEED OPERATIONS**

Production is the hourly clearing rate usually expressed in hectares or acres.

For many land clearing operations, production is calculated by multiplying the tractor speed by the width of cut and converting to hectares or acres per hour.

Metric system:

The base formula is:

$$\frac{\text{Width of cut (meters)} \times \text{speed (km/h)}}{10} = \text{hectares/h}$$

When an efficiency of 82.5% is used, the formula becomes:

$$\frac{\text{Width of cut (m)} \times \text{speed (km/h)} \times .825}{10} = \text{hectares/h}$$

English measure:

$$\frac{\text{Width of cut (ft)} \times \text{speed (mph)}}{43,560 \text{ (ft}^2\text{)}} = \text{acres/hr}$$

The American Society of Agricultural Engineers formula for estimating hourly production of a constant speed operation is based on 82.5% efficiency. With this efficiency, the formula becomes:

$$\frac{\text{Width of cut (ft)} \times \text{speed (mph)} \times .825}{43,560 \text{ (ft}^2\text{)}} = \text{acres/hr}$$

Width of cut is the effective working width of the equipment and may not be the same as its rated width. Working width should be measured on the job but can be estimated when necessary.

The actual machine speed can be determined by measuring the amount of time to travel a given distance. When using the metric system, the time to travel 16.7 meters or a multiple thereof, can be converted into kilometers per hour.

$$\frac{1.0}{\text{(Time in min. to travel 16.7 meters)}} = \text{speed (km/h)}$$

Since 88 ft/min. equals one mph, the lapsed time to travel 88 ft, or a multiple of 88 ft, can easily be converted into miles per hour.

$$\frac{1.0}{\text{(Time in min. to travel 88 ft)}} = \text{speed (mph)}$$

The following nomographs in both the Metric and English systems convert speed and width of cut directly into acres or hectares per hour at 82.5% efficiency without the need for calculations.

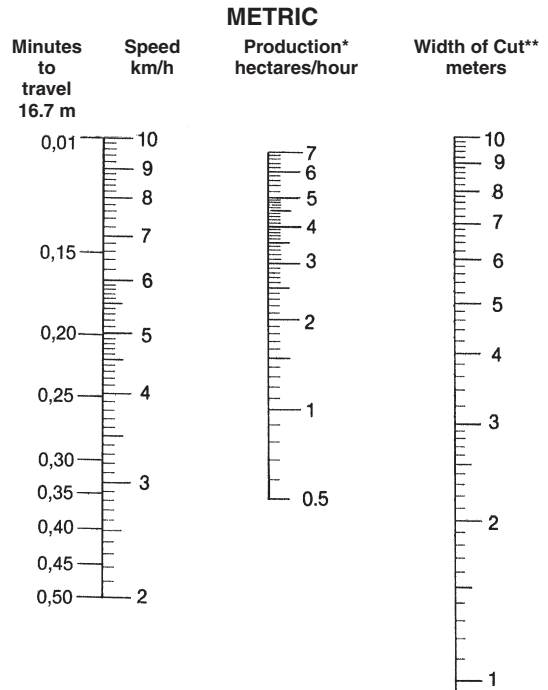

\*Based on 82.5% efficiency.  
 \*\*When width of cut exceeds 10 meters, use a multiple of the width of cut and increase production proportionately.

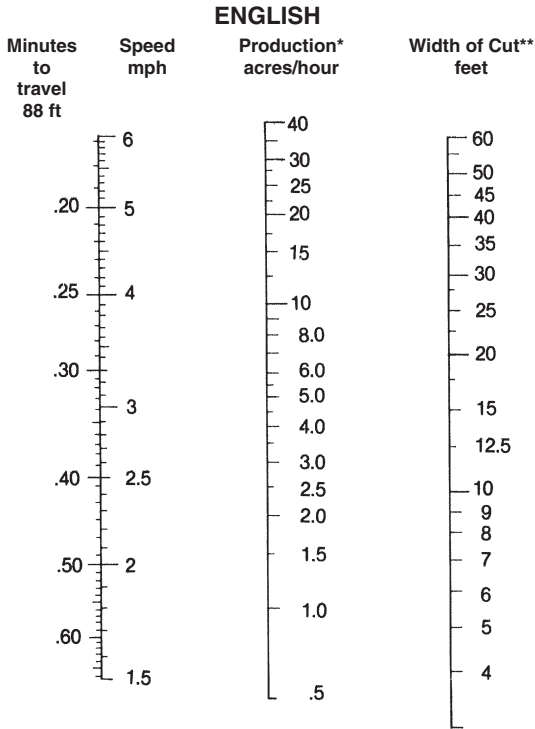

\*Based on 82.5% efficiency.

\*\*When width of cut exceeds 60 feet, use a multiple of the width of cut and increase production proportionately.

## CUTTING PRODUCTION ESTIMATING

Most land clearing operations such as bulldozing, cutting, grubbing, raking and piling are not performed at constant speed. Because off-the-job production is difficult to estimate for these operations, Rome Industries has developed formulas for estimating cutting and piling time. These formulas take into consideration variable prime mover speeds through a factor, "B", the base time for each tractor to cover one hectare (2.47 acres) of light material.

To estimate **tractor cutting time per hectare** (2.47 acres) on a specific land clearing job, apply the factors shown in the following table, together with data obtained from the job survey, in the formula:

$$T = X [A(B) + M_1N_1 + M_2N_2 + M_3N_3 + M_4N_4 + DF]$$

where

T = Time per hectare (2.47 acres) in minutes

X = Hardwood or density factor affecting total time

A = Density or vine presence factor affecting base time

B = Base time for each tractor per hectare (2.47 acres)

M = Minutes per tree in each diameter range

N = Number of trees per hectare (2.47 acres) in each diameter range obtained from field survey

D = Sum of diameter in 30 cm (1 ft) increments of all trees per hectare (2.47 acres) above 180 cm (6 ft) in diameter at ground level obtained from field survey

F = Minutes per 30 cm (1 ft) of diameter for trees above 180 cm (6 ft) in diameter.

Hardwoods affect over-all or total time as follows:

75-100% hardwoods: Add 30% to total time (X = 1.3)

25-75% hardwoods: No change (X = 1.0)

0-25% hardwoods: Subtract 30% from total time (X = 0.7)

## Production Factors for Felling with Rome K/G Blades

Tractor	Base Minutes per hectare (2.47 acres) "B"	Diameter Range				Dia. above 180 cm per 30 cm (6' per foot) "F"
		30-60 cm (1-2 ft) "M <sub>1</sub> "	60-90 cm (2-3 ft) "M <sub>2</sub> "	90-120 cm (3-4 ft) "M <sub>3</sub> "	120-180 cm (4-6 ft) "M <sub>4</sub> "	
165 hp	85	0.7	3.4	6.8	—	—
230 hp	58	0.5	1.7	3.3	10.2	3.3
305 hp	45	0.2	1.3	2.2	6.0	1.8
405 hp	39	0.1	0.4	1.3	3.0	1.0

## Explanation of columns in table:

**Tractor** — Based on current model tractors (power shift when applicable) working on reasonably level terrain (below 10% grade) with good footing, no stones, average mixture of soft and hard woods. Tractor is in proper operating condition, blade is sharp, and properly adjusted.

**Base Minutes** — The base figures represent the number of minutes required for each tractor to cover a hectare (2.47 acres) of light material where no trees require splitting or other individual treatment. Time required is affected by the density of material less than 30 cm (1 ft) in diameter and the presence of vines.

- dense — 1480 trees/hectare (600 or more trees/acre): Add 100% to base time (A = 2.0)
- medium — 990-1480 trees/hectare (400-600 trees/acre): No change (A = 1.0)
- light — less than 990 trees/hectare (400 trees/acre): Subtract 30% from total time (A = 0.7)

- Cutting
- Piling

Presence of heavy vines: Add 100% to base time (A=2.0). Very heavy vines add 300% to base time. (A=3.0)

*Dia. Range* — M<sub>1</sub> represents minutes required to cut trees from 31-60 cm (1-2 ft) in diameter at ground level.

- M<sub>2</sub> same for trees 61-90 cm (2-3 ft) diameter.
- M<sub>3</sub> same for trees 91-120 cm (3-4 ft) diameter.
- M<sub>4</sub> same for trees 121-180 cm (4-6 ft) diameter.

*For Dia. above 180 cm (6 ft)* — The figures in this column represent size the number of minutes required per 30 cm (1 ft) of diameter for each tractor to cut trees above 180 cm (6 ft) in diameter. Thus, to fell a 240 cm (8 ft) diameter tree would require 8 × 1.8 or approximately 14.4 minutes with a D8T.

Example problem:

Calculate the felling production of a D8T with K/G Blade in these conditions: reasonably level terrain, firm ground, well drained, 85% hardwoods with heavy vines and the following average tree count per hectare (2.47 acre):

Diameter Range	Less than 30 cm (1 ft) "B"	31-60 cm (1-2 ft) "N <sub>1</sub> "	61-90 cm (2-3 ft) "N <sub>2</sub> "	91-120 cm (3-4 ft) "N <sub>3</sub> "	121-180 cm (4-6 ft) "N <sub>4</sub> "	Sum Dia's Above 180 cm (6 ft) "D"
Number of Trees	1100	35	6	6	4	488 cm (16 ft)

**Solution:**

$$\begin{aligned}
 T &= X [A(B)+M_1N_1+M_2N_2+M_3N_3+M_4N_4+DF] \\
 T &= 1.3 [2.0 (45)+0.2 (35)+1.3 (6)+2.2 (6)+6 (4)+16 (1.8)] \\
 &= 1.3 (90+7+7.8+13.2+24+28.8) \\
 &= 1.3 (170.8) \\
 &= 222 \text{ minutes/hectare (90 min/acre)}
 \end{aligned}$$



Where the job requires grubbing trees and stumps greater than 30 cm (1 ft) in diameter at the same time the trees are sheared, use the same basic procedure as defined above including the variables for the presence of hardwoods. After time per hectare (acre) in minutes has been determined, increase the over-all or total time by 25%.

Where the job requires re-entering the area (after all trees have been sheared) to remove stumps with a tilted shearing blade or stump, increase the total time by 50%.

**PILING PRODUCTION ESTIMATING**

A procedure has also been developed for estimating piling production for a tractor equipped with a K/G blade or rake.

To estimate tractor hours per hectare (acre) on a specific land clearing job, apply the factors shown in the following table with data obtained from the job survey, in the formula:

$$T = B+M_1N_1+M_2N_2+M_3N_3+M_4N_4+DF$$

where

- T = Time per hectare (2.47 acre) in minutes.
- B = Base time for each tractor per hectare (2.47 acre).
- M = Minutes per tree in each diameter range.
- N = Number of trees per hectare (2.47 acre) in each diameter range obtained from field cruise.
- D = Sum of diameter in 30 cm (1 ft) increments of all trees per hectare (2.47 acre) above 180 cm (6 ft) in diameter at ground level obtained from field cruise.
- F = Minutes per 30 cm (1 ft) of diameter for trees above 180 cm (6 ft) in diameter.

**Production Factors for Piling in Windrows\***

Tractor	Base Minutes per hectare (2.47 acres) "B"	Diameter Range				Dia. above 180 cm per 30 cm (6' per foot) "F"
		30-60 cm (1-2 ft) "M <sub>1</sub> "	60-90 cm (2-3 ft) "M <sub>2</sub> "	90-120 cm (3-4 ft) "M <sub>3</sub> "	120-180 cm (4-6 ft) "M <sub>4</sub> "	
165 hp	157	0.5	1.0	4.2	—	—
230 hp	125	0.4	0.7	2.5	5.0	—
305 hp	111	0.1	0.5	1.8	3.6	0.9
405 hp	97	0.08	0.1	1.2	2.1	0.3

\*May be used with most types of raking tools and angled shearing blade. Windrows to be spaced approximately 61 meters (200 feet) apart.

**Explanation of columns in table:**

*Tractor* — Production with tractor working alone based on current model tractors (power shift when applicable) working on reasonably level (below 10% grade) terrain with good footing, no stones, average mixture of soft and hard woods. The tractor is in proper operating condition. Decrease total time by 25-50% depending on the number and size of trees when using three or more tractors in combination.

*Base Minutes* — The base figures represent the number of minutes required for each tractor to cover a hectare (2.47 acres) of light material.

*Dia. Range* —  $M_1$  represents minutes required to pile trees from 31-60 cm (1-2 ft) diameter at ground level.

$M_2$  same for trees 61-90 cm (2-3 ft) diameter.

$M_3$  same for trees 91-120 cm (3-4 ft) diameter.

$M_4$  same for trees 121-180 cm (4-6 ft) diameter.

*For Dia. above 180 cm (6 ft)* — The figures in this column represent for each tractor size the number of minutes required per 30 cm (1 ft) of diameter to pile trees above 180 cm (6 ft) in diameter. Thus, to pile a 240 cm (8 ft) diameter tree would require  $8 \times 0.9$  or approximately 7.2 minutes with a D8T tractor.

Where the job requires piling of grubbed trees and stumps greater than 30 cm (1 ft) in diameter, use the same basic procedure defined above and then increase over-all or total time by 25%.

In dense small diameter brush with few or no large trees, or when cutting is vine entangled, reduce the base time by 30%.

Example problem:

Calculate the windrow piling production of a D7R Series 2 with Rake in level terrain, no grubbing, and average mixture of hardwoods and softwoods where the average tree count per hectare (2.47 acres) is:

Diameter Range	Less than 30 cm (1 ft) "B"	31-60 cm (1-2 ft) "N <sub>1</sub> "	61-90 cm (2-3 ft) "N <sub>2</sub> "	91-120 cm (3-4 ft) "N <sub>3</sub> "	121-180 cm (4-6 ft) "N <sub>4</sub> "	Sum Dia's Above 180 cm (6 ft) "D"
Number of Trees	1100	35	6	6	2	0

**Solution:**

$$\begin{aligned}
 T &= B + M_1N_1 + M_2N_2 + M_3N_3 + M_4N_4 + DF \\
 &= 125 + 0.4(35) + 0.6(6) + 2.5(6) + 5.0(2) + [DF=0] \\
 &= 42.6 \\
 &= 177.6 \text{ minutes/hectare (72 min/acre)}
 \end{aligned}$$



To find the number of machines required for each operation, use the formula:

$$\text{Hr/hectare (acre)} \times \text{number of hectares (acres)} = \text{number of machines needed}^*$$

\*Average machine production for all operation in hr/hectare (acre).

To cost estimate each method or phase of operation, use this calculation:

$$\text{Owning and Operating cost/hr} \times \text{hr/hectare (acre)} \times \text{number of hectares (acres)} = \text{cost}$$

Because of the many variables that increase or decrease production, these formulas should be considered only as guidelines in arriving at a rough production estimate. This estimate should be tempered by personal judgment based on past experience and personal knowledge of the area.

**BLADE RAKES**

Tractor Model and Dozer		6A	D6T 6S	6S LGP	7A	D7R Series 2 7S	7S LGP
Raking Width	m ft	3.3 10'10"	2.62 8'6"	3.3 10'10"	3.72 12'3"	3.18 10'5"	3.66 12'
Opening at Tooth Tips	mm in	356 14"	305 12"	310 12.22"	381 15"	381 15"	381 15"
Tooth Penetration	mm ft/in	432 17"	457 18"	406 16"	559 1'10"	559 1'10"	559 1'10"
Total Weight	kg lb	718 1585	675 1490	825 1820	1144 2525	1100 2420	1119 2470

**RAKES FOR WHEEL LOADERS**

Wheel Loader Model and Rake Type		914G II Loader Rake	924H Loader Rake	928H Loader Rake	930H Loader Rake	950H/ 962H Loader Rake	966H/ 972H Loader Rake
Raking Width	mm ft	2210 7'3"	2489 8'2"	2845 9'4"	2845 9'4"	3048 10'0"	3353 11'0"
Tooth Penetration	mm ft	762 2'6"	646 2'1"	740 2'5"	650 2'2"	965 3'2"	1143 3'9"
Opening at Tooth Tips	mm in	318 12.75"	305 12"	305 12"	356 14"	298 11.75"	330 13"
Rake Weight	kg lb	770 1700	1038 2284	1378 3032	1460 3212	1590 3500	2210 4880

**RAKES FOR TRACK LOADERS**

Track Loader Model and Rake Type		953D Loader Rake	963D Loader Rake
Raking Width	mm ft	2845 9'4"	2388 7'10"
Tooth Penetration	mm ft	635 2'1"	635 2'1"
Opening at Tooth Tips	mm in	298 11.75"	330 13"
Rake Weight	kg lb	1450 3200	1450 3200

This listing is not all-inclusive. Contact your Cat dealer for special attachment needs.

# WASTE HANDLING

## CONTENTS

Introduction .....25-1

## TRANSFER STATIONS

Transfer Stations, MRF's (Material Recovery Facilities) Sorting Stations, Recycling Stations .....25-1  
Equipment Selection .....25-3  
Machine Selection Factors .....25-3  
Track-Type Tractors .....25-3  
Track Loaders .....25-4  
Landfill Compactors (Steel Wheeled) .....25-4  
Wheel Loaders .....25-4  
Hydraulic and Wheeled Excavators .....25-5

## LANDFILLS

Landfill Methods .....25-6  
Equipment Selection .....25-6  
Track-Type Tractors .....25-6  
Track Loaders .....25-7  
Landfill Compactors .....25-7  
Wheel Loaders .....25-7  
Wheel Tractor-Scrapers .....25-7  
Articulated Trucks .....25-7  
Machine Selection Factors .....25-8  
Refuse Densities .....25-11  
Factors Governing Compaction .....25-11  
Compaction Comparison Estimate .....25-12  
Computer Aided Earthmoving Systems (CAES) .....25-12  
Landfill Estimating .....25-13  
Example Problems .....25-13

## TRACK-TYPE TRACTORS

Features .....25-15  
Specifications .....25-16  
Blade Specifications .....25-21

## TRACK LOADERS

Features .....25-25  
Specifications .....25-26  
Attachments .....25-27

## LANDFILL COMPACTORS

Features .....25-28  
Specifications .....25-29  
Blade Specifications .....25-30

## WHEEL LOADERS

Features .....25-31  
Specifications .....25-32

## INTRODUCTION

An increasing volume of refuse is generated by every person, commercial entity and household day after day ... 365 days a year. Disposal of this waste is a major problem worldwide. Increased governmental legislation designed to protect the environment and rising transportation and land acquisition costs have made waste disposal a significant user of earthmoving and specialty mobile equipment.

## TRANSFER STATIONS

### TRANSFER STATIONS, MRF'S, (MATERIAL RECOVERY FACILITIES) SORTING STATIONS, RECYCLING STATIONS

#### Changing attitudes in waste applications

The growth in transfer stations has increased as the amount of material that is being recycled or otherwise diverted from landfill disposal has increased. As a result transfer stations, MRF's, (material recovery facilities), sorting stations and recycling stations, are becoming a more important part of the waste stream. As the number of disposal sites continues to decline and/or move further away from city centers, the number of transfer stations must increase to accommodate and redirect waste to the appropriate disposal facilities.

### Primary role

- Transfer stations, are designed to consolidate the loads of several delivery vehicles into long-haul transfer trailer or rail haul units. On average 2–5 inbound loads for transfer trailers and 5 or more for rail haul units can be consolidated into one outbound load. As a result transfer stations offer cost savings over direct haul to the landfill.
- MRF's, Sorting Stations, and Recycling Stations are designed to divert recyclable materials from the waste stream. Depending whether the material is pre-sorted, co-mingled, or MSW (municipal solid waste), the goal is to divert recyclable material for re-consumption and lower the amount of waste placed into the landfill thereby extending the landfills natural life.
- Safety is a major concern in today's Waste Industry Transfer Stations, Sorting Stations, MRF's, and Recycling Stations, all help reduce primary road and landfill traffic, by helping reduce smaller waste trucks and public traffic, leading to improved safety for everyone.

### Types of transfer stations

The two most popular styles of transfer stations in North America are top loading and compaction. While there are many different types of transfer stations, most operate out of these two designs.

Top loading systems are the most common and simplest to operate. Five types of top loading arrangements include direct loading, full separation, half-separation, floor loading, and surge pit. Depending on the type of transfer station, wheel loaders, track loaders, track-type tractors, compactors, and excavators, can be utilized alone or together in systems providing quick efficient waste handling.

Compaction transfer stations provide hydraulic compaction either prior to, or during the loading of the hauling vehicle. It is important to note this type of transfer station can utilize all of the same design features of the platform design except for the direct load and half-separation designs.

### Material Recovery Facility (MRF's), Sorting Stations, and Recycling Stations

A well-coordinated recycling program can reduce volume going to the landfill by up to 50% or more. The types of facility designs that sort recyclables out of the waste stream are:

1. *Recycling Facility* — Recyclables are separated at the source prior to being loaded into the haul vehicle. At the recycling station, the materials are unloaded, stored, sold and shipped to be remanufactured or recycled.
2. *Clean MRF's* — A "clean" MRF accepts source-separated recyclable material from residential and commercial sources delivered in separate collection vehicles.
3. *"Dirty" MRF* — A dirty MRF accepts mixed waste that later may be sorted for recycling; or source-separated waste that is delivered in the same collection vehicle (i.e. blue bag systems)
4. *Sorting Stations* — some transfer stations are designed for some waste diversion and recycling from mixed waste streams, and are normally described as 'sorting' stations.

### Typical Applications for Transfer Stations, Recycling Centers, MRF's, and Sorting Stations

There is a wide range of variability in transfer station applications and operations. Therefore, depending on facility size, amount of material handled, type of transfer station, etc., a wide variety of machines could be utilized.

Typically, residential and commercial waste trucks deposit the waste onto a tipping platform. A wheel loader then stockpiles it, loads it into the transfer trailers/rail units or moves it onto a conveyor or belt line for recycling. Some transfer stations utilize a hydraulic excavator to help sort, top off, and compact the material into the transfer trailer/rail units.

"Volumetric consolidation of material" is a method that is increasingly becoming more popular within transfer stations throughout the U.S. Volumetric consolidation of material prior to load-out helps maximize the allowable weight carried by each haul unit. Common machines used for material consolidation are, track-type tractors and track loaders. These machines are normally equipped with track shoes that help in shredding, compression, and compaction. Compactors can be used for material reduction and are normally aided by a combination of either wheel loaders and/or excavators.

For transfer, recycling, and sortings stations, and MRF's a vast amount of support equipment is utilized. These range from, skid steer loaders, backhoe loaders, compact wheel loaders, IT's, and small/medium wheel loaders.

## EQUIPMENT SELECTION

As in the landfill application, the largest single cost for daily operation in transfer stations, etc., is purchasing, operating, and maintaining the equipment. Undersized, inadequate or unreliable equipment results in higher maintenance and repair costs and improper operations.

Equipment in transfer stations and related applications perform these functions.

1. **Stockpiling the waste** once it is dumped onto the tip platform or in the surge pit. Machines used could be wheel loaders, track loaders, or track-type tractors, or any combination of these.
2. **Loading the waste** into the transfer trailers or rail cars. Material is either pushed, loaded and carried, or grappled into the transport vehicles. Wheel loaders, track loaders, track-type tractors, excavators, or any combination of these can be utilized.
3. **Support equipment** for all the different styles of transfer stations, recycling stations, sorting stations, and MRF's is a must. IT wheel loaders equipped with brooms, forks, specialty buckets, etc. can increase production and efficiency of the tip floors and load out areas. Skid steers, backhoe loaders, telehandlers and small compact equipment, with couplers and versatile attachments, can perform many necessary duties from clean up to load out.
4. **Reducing volume of material** is accomplished by continuous running over the waste, turning the waste over, and 'working' the waste. This type of operation compacts and shreds the waste allowing for less volume but higher weights in on road or rail haul transfer vehicles. Compactors, track-type tractors, and track-type loaders, equipped with wheels or undercarriages specifically designed to densify the waste, are normally utilized in this type of application.

## Machine Selection Factors

As in landfill applications, selecting the type, size, quantity, and combination of machines required in transfer stations and other sorting applications is determined by the following parameters.

1. Amount and type of waste to be handled daily — (daily tonnage) — again, machines should be spec'd towards peak times.
2. Type and size of the facility — top loading/compaction and the various floor arrangements possible.
3. Facility/load out dynamics
  - a. floor size — dimensions of the tip area, load out area, surge pit and storage area
  - b. ceiling height
  - c. haul unit specifications for load out
  - d. traffic patterns
4. Densification/compaction requirements for necessary load out tonnage's.
5. Supplemental tasks performed during the total workday.
6. Budget
7. Growth

## Track-Type Tractors

Track-type tractors are designed and guarded to accommodate all waste applications. Used primarily to aid spreading and compaction on landfills, track-type tractors offer another alternative for densification and waste movement in large transfer stations. Most track-type tractors are used in surge pit style transfer stations. In this application, waste can be dumped on a second level below the main tipping floor. The track-type tractor then works the waste, spreading, densifying, and loading haul vehicles for the trip to the landfill. This design is used when maximum volume reduction is required and/or when peak rate of waste exceeds the available floor space.



- Track Loaders
- Landfill Compactors
- Wheel Loaders

### Track Loaders

Track loaders are designed and guarded for many different types of waste applications. Because of its versatility, the track loader can perform several different functions within the transfer station. The machine's weight compacts the waste reducing volume and increasing density. This allows haul vehicles to obtain the maximum weight permissible for road or rail. They can either work alone, or in tandem with wheel loaders or excavators to load the haul vehicles. Equipping track loaders with multi-purpose buckets increases their versatility in allowing the operator to selectively grapple items for sorting and disposal.

### Landfill Compactors\*

Landfill compactors are specialized pieces of equipment primarily designed for spreading and compacting large volumes of waste in a landfill environment. However, in some instances around the world where transfer stations have a large enough working area and densification of the waste is an operational goal, landfill compactors are being utilized.

Landfill compactors offer two major advantages.

1. They are already configured and guarded to work in a waste environment.
2. They are capable of achieving superior compaction levels as compared to other mobile equipment.

Although Landfill compactors are not typically viewed as a primary piece of transfer station equipment, they are occasionally being used and may offer an alternative solution to a transfer station operator. Please consider maximum density, weight needed in the hauler, tip floor size and possible contact by the compactor.

\*For this type of application, it is not recommended to use any steel wheeled compactor larger than the 826.

### Wheel Loaders

Wheel loaders are often one of the primary tools used in transfer stations to load and separate refuse. Almost all styles of transfer stations will utilize a wheel loader either on their tip floor, load out area, or as a support piece of equipment. Wheel loaders perform a variety of tasks such as, stockpiling of waste on the tip floor, feeding belts for the sorting line, top loading haul vehicles either same level, half separated, or full separation, and clean up around the facility. These machines are normally equipped with a wide variety of buckets, attachments, and tires. A good knowledge of the facility, its waste stream, and its limiting factors is needed for proper machine selection.

Depending on the size and design of the facility, amount and type of waste stream, and type of job the machine needs to perform, there are several models available for machine selection. Waste Handling Packages are offered on our large to medium wheel loader line and limited waste handling guarding packages are offered on our smaller wheel loaders.

Care should be taken in sizing your equipment for your peak periods, and your peak and support needs.

- **Compact wheel loaders (902–908)** — Normally utilized in small tonnage recycling stations, and support machines where maneuverability in cramped areas is needed.
- **Small wheel loaders (914G–930H)** — Used for maneuverability in stockpiling, sorting, and loading of types of material in transfer, recycling, and sorting stations. Also used as support and backup machines in larger applications.
- **Medium — large wheel loaders (938H–988H)** — Utilized for waste movement on tip floors and load out areas, the size, weight to horsepower ratios, and many options make these machines the work horse of the recycling, transfer, and sorting stations.
- **IT's or Integrated ToolCarriers (IT14G–IT62H)** — IT machines offer maneuverability and versatility in many different recycling, transfer, and sorting station applications. A wide variety of main and support attachments can be utilized daily for many different jobs to be performed around these facilities.

**Wheel Loader/IT Operating Recommendations**

Tons per Day Volume	Clean MRF/ Recycling	Dirty MRF Sorting Station	Waste Transfer Station	C and D Transfer Station	C and D MRF
0-100	902-930	924-930	924-930	930-950 <sup>b</sup>	930-966
100-350	914-924 <sup>a</sup>	924-930 <sup>a</sup>	924-930 <sup>a</sup>	950-966 <sup>d</sup>	950-966 <sup>d</sup>
350-500	930-938	924-938	950-966	966-980	966-980 <sup>a</sup>
500-1000	930-938 <sup>a</sup>	938-950 <sup>e</sup>	950-966 <sup>c</sup>	966-980 <sup>a,e</sup>	980 <sup>e</sup>
1000-1500	938-950 <sup>e</sup>	938-966 <sup>e</sup>	966-980 <sup>d</sup>	966-980 <sup>d,e</sup>	980 <sup>d,e</sup>
1500-2000	950-966 <sup>e</sup>	966-980 <sup>e</sup>	966-980 <sup>d</sup>	966-980 <sup>d,e</sup>	980 <sup>e</sup>
2000-2500	950-966 <sup>e</sup>	966-980 <sup>d,e</sup>	966-980 <sup>d,e</sup>	966-980 <sup>e</sup>	980 <sup>e</sup>
2500-3000	950-966 <sup>e</sup>	966-980 <sup>e</sup>	966-980 <sup>e</sup>	966-980 <sup>e</sup>	980 <sup>e</sup>
3000 Plus	966-980 <sup>e</sup>	980 <sup>e</sup>	980 <sup>e</sup>	980 <sup>e</sup>	980 <sup>e</sup>

C and D = Construction and Demolition

**Special Considerations**

All Machine Families — standard, IT (Integrated Toolcarrier), and custom product quick couplers should be considered available (contact dealer).

MRF — (Material Recovery Facility) — Clean and Dirty.

Clean MRF/Recycling — source separated material — no damaging material involved.

Dirty MRF/Sorting Station — non-separated material — has to be sorted — could involve moving damaging material.

a = Multiple machines recommended (contact your local Cat® dealership for recommendations)

b = Depends on type and density of C and D material

c = Waste stream mixture may require multiple machines

d = Operating hours may require additional machines

e = Multiple machines required

**Additional Considerations**

All facilities are different and require special considerations when ordering and specifying equipment. Types of attachments/buckets and operating hours will dictate type of equipment and size necessary. Machine weight has to balance power for best traction on slick floors.

Front light guards, hinged crankcase guards, and power train guards (standard on the 938H, 950H, and 966H) help protect machine parts.

Optional guarding attachments available for the 924H, 930H, and IT38H include: windshield guards, engine crankcase guards, light guards, radiator guards and tilt cylinder guards for the 924H high lift.



**Hydraulic and Wheeled Excavators**

Hydraulic excavators are often found in recycling, transfer, and sorting stations as a primary tool for loading transfer trailers, railcars, waste compaction and for presorting material being loaded onto the sorting conveyors. The main advantages of an excavator in this role are its fast cycle times, its ability to maneuver within confined spaces, and the versatility of the many work tools with which a hydraulic excavator can be equipped. Certain tools are ideal when sorting or separating refuse is necessary, while others can be used for simple, high-production loading and compaction.

When sizing an excavator, it is important to take into account the daily tonnage of an operation as well as facility constraints, such as ceiling height and floor size. While no official “waste handling arrangement” is currently available for excavators, Caterpillar has configured excavators for many heavy-duty applications and all of the components that would ideally suit a machine to a transfer station application are available.

Wheeled hydraulic excavators add the benefits of greater speed for moving about the transfer station and therefore can be positioned to work in virtually any area of the transfer station within minutes.

They can also be equipped with an optional 1.2 m (4'0") fixed or 1.95 m (6'6") hydraulic cab riser for improved capability to see down in the “hole” when loading through the floor or seeing into trailers positioned at the same ground level as the wheeled excavator.

## LANDFILLS

The most commonly accepted way to dispose of refuse is to bury it in a landfill. A landfill protects the environment by disposing solid waste on land in an engineered cell. Building a cell involves spreading the waste in thin layers, compacting it to the smallest practical volume, covering it with soil by the end of each working day, and compacting the cover material. Proper equipment selection and operating technique can maximize refuse and cover compaction and extend the operational landfill life.

## LANDFILL METHODS

There are three basic landfill methods:

In the *area* method, waste is usually deposited at the toe of the previously compacted cell and then spread and compacted. This method is attractive for landfills receiving over 450 metric tons (500 tons) of refuse per day because it reduces truck unloading congestion. Cover material is normally handled by articulated trucks or wheel tractor-scraper from nearby borrow sites.

The *trench* method is normally found at smaller landfills where the ground water table is deep. A trench is excavated and refuse is deposited and compacted within it. Excavated material becomes the cover material. Since the trench working face is narrow, truck congestion can occur. This method is usually attractive to landfills receiving under 450 metric tons (500 tons) of refuse per day.

The *ramp* method combines the characteristics of both area and trench designs. Refuse is dumped, spread and compacted on existing slopes and covered with material excavated directly in front of the working face. The excavated area becomes part of the next cell. This is a good way for a landfill to begin operation with a minimum of equipment expenditures.

## EQUIPMENT SELECTION

A landfill's largest single cost for daily operation is purchasing, operating and maintaining the mobile equipment. Undersized, inadequate or unreliable equipment results in breakdowns, higher operating costs and improper landfill operation.

Landfill equipment performs three distinct functions:

1. Waste handling and compaction equipment dispose of the waste. Track-type tractors, track loaders, and landfill compactors are the primary machines.
2. Cover material handling machines provide daily cover requirements. If supplying cover material is a machine's sole function at a landfill, it can be selected on the basis of normal earthmoving considerations, such as material characteristics, distance to borrow areas, volume to be transported, and other basic earthmoving principles, i.e., maximizing earth movement in the least amount of time at the lowest cost per yard.
3. Support equipment includes motor graders, backhoe loaders, hydraulic excavators, water trucks, air compressors, service vehicles, water pumps, generators and any other necessary equipment.

## Track-Type Tractors

The track-type tractor is the most popular and versatile machine on a landfill. They not only spread and compact refuse and cover material, they also prepare the site, rip cover material, build haul roads, knock down trees, remove stumps, and work in virtually all weather conditions. They are well-suited for all three landfill methods (area, ramp, and trench).

The crawler tractor can achieve compaction densities of 475 to 590 kg/m<sup>3</sup> (800-1000 lb/yd<sup>3</sup>). Maximum compaction is achieved when it works on a 3:1 or less slope, permitting the grousers to rip and tear while pushing and compacting waste up-slope. Economic limit of cover or waste movement by a track-type tractor is normally under 90 m (300 ft).

- Track Loaders
- Wheel Loaders
- Landfill Compactors
- Wheel Tractor-Scrapers
- Articulated Trucks

### **Track Loaders**

Track loaders are highly versatile allowing them to perform many applications. Small landfills under 135 metric tons (150 tons) per day generally utilize a minimum amount of equipment. Track loaders can serve both the waste handling and cover material functions.

The track loader is an ideal machine for the trench method. Since the bucket does not extend outside the tracks, it can obtain full compaction to the trench walls. Rippers can be attached to handle frozen cover material. Compaction densities are similar to or slightly higher than the track-type tractor — 475 to 590 kg/m<sup>3</sup> (800-1000 lb/yd<sup>3</sup>). Many people believe track loaders equipped with single grouser shoes provide maximum demolition and compaction densities. Loading the bucket during compaction passes increases weight helping achieve higher densities.

Equipping track loaders with multi-purpose buckets increases their versatility in single machine applications, allowing the operator to selectively grapple items out of the working face.

### **Landfill Compactors**

Landfill compactors are specialized pieces of equipment effective in spreading and compacting large volumes of waste. Compactors offer higher operational speeds than track machines. This is the recommended machine if more than one spreading and compaction machine is needed and waste does not have to be pushed more than 90 m (300 ft).

Landfill compactors over 20 410 kg (45,000 lb) operating weight achieve the highest compaction levels — from 710 to 950 kg/m<sup>3</sup> (1200-1600 lb/yd<sup>3</sup>).

Landfill compactors normally operate on slopes no steeper than 4:1 due to reduced compaction and operational safety. Compactors should not be used to excavate cover material.

### **Wheel Loaders**

Although not recommended as a waste handling and compaction machine, wheel loaders are used by those communities sharing a single machine which travels from landfill to landfill. Versatility and mobility are the primary wheel loader advantages. In landfills over 272 metric tons (300 tons) per day, wheel loaders will sometimes be used to perform general clean-up tasks.

### **Wheel Tractor-Scrapers**

A scraper can be used to excavate trenches for site preparation, but usually performs a cover operation at a landfill and is most economical at distances over 185 m (600 ft). A scraper should be selected as if it were performing a typical earthmoving job.

Preferably, the scraper unloads the cover material close to the working face, either at the base or top. The cover material is then spread by the machine(s) working on the refuse. This reduces the possibility of tire damage from driving over the refuse. Foam filled tires are not recommended for scrapers due to the high travel speeds. Since excavating and transporting cover material is a major expense at a landfill, scrapers with work alone capability have been the most popular.

### **Articulated Trucks**

Articulated trucks are versatile, highly maneuverable, all-weather haulers that can negotiate poor underfoot conditions and tight spaces normally found in landfills. In combination with a variety of loading tools, articulated trucks typically work in site preparation, cell construction, hauling cover material, and are economically effective at haul distances ranging from 0.1 km-5 km (600 ft-3 miles). In dump configuration, cover material can be dumped close to the face and spread by other machines. In ejector configuration, articulated trucks provide on-the-go dumping and can operate in soft material and on side-slopes that would not be suitable for machines in dump configuration. In addition, Cat articulated trucks are available in a range of container handler and refuse body configurations for specialized landfill applications.

**Machine Selection Factors**

Selecting the type, size, quantity, and combination of machines required to spread, compact, and cover varying daily refuse volumes is determined by the following parameters:

1. Amount and type of waste to be handled (daily tonnage)
  2. Amount and type of soil cover to be handled
  3. Distance cover material to be transported
  4. Weather conditions
  5. Compaction requirements
  6. Landfill method utilized
  7. Supplemental tasks
  8. Budget
  9. Growth
- A. *Daily tonnage and type of waste* — Amount of waste produced by a community is the major variable in selecting the appropriate size machine. The chart serves as a guideline in sizing a landfill machine. For example, if a community generates approximately 180 metric tons (200 tons) of refuse per day, a D6 or 953 and a 816F2 Landfill Compactor should be considered. See **Machine Tonnage and Usage Selection Guide** chart on next page.

Type of waste to be handled will strongly influence machine selection. The major solid waste components for a community should be identified and the proper machine chosen based on the type of waste and the compaction desired. For example, if the site receives a high proportion of noncompactible heavy industrial waste (rocks, bricks, concrete, reinforcing rod, etc.) a compactor might not achieve normal compaction densities and the pushing and tractive ability of a track-type tractor may be needed. However, tracked machines have more difficulty compacting bulk waste, trees, road materials, iron, and telephone poles than a landfill compactor.

On average, each American generates 2 kg (4.5 lb) of waste per day. While waste composition varies from location to location, even within a community, the following figures are representative of the waste stream in the U.S.:

<b>2003 Total U.S. Waste Generation*</b>	
Paper	35.2
Yard Waste	12.1
Food	11.7
Plastics	11.3
Metals	8
Rubber, Leather, Textiles	7.4
Glass	5.3
Wood	5.8
Other	3.4

\*Before Recycling.

Courtesy U.S. EPA

**NOTE:** Moisture content can have a significant effect on weight characteristics. Field tests have indicated moisture content can vary from 10-80% during dry and wet seasons.

Machine Tonnage and Usage Selection Guide	D7R Series 2											
	D6T	D7E	D8T	D9T	D10T	953	963	973	816F2	826H	836H	
<b>0 to 45.3 Metric Tons Per Day (0 to 50 Tons Per Day)</b>												
MSW Landfills	×					×						
MSW/Other Landfills	×					×						
Construction and Demolition Landfills		×	×					×				
<b>45.3 to 136 Metric Tons Per Day (50 to 150 Tons Per Day)</b>												
MSW Landfills	×					×						
MSW/Other Landfills	×					×			×			
Construction and Demolition Landfills		×	×					×		×		
<b>136 to 227 Metric Tons Per Day (150 to 250 Tons Per Day)</b>												
MSW Landfills	×					×						
MSW/Other Landfills	×					×			×			
Construction and Demolition Landfills		×	×	×				×		×		
<b>227 to 317.5 Metric Tons Per Day (250 to 350 Tons Per Day)</b>												
MSW Landfills	×					×	×		×			
MSW/Other Landfills		×	×			×	×		×			
Construction and Demolition Landfills				×	×			×		×		
<b>317.5 to 453.6 Metric Tons Per Day (350 to 500 Tons Per Day)</b>												
MSW Landfills		×	×				×		×	×		
MSW/Other Landfills		×	×				×		×	×		
Construction and Demolition Landfills				×	×			×				×
<b>453.6 to 680.4 Metric Tons Per Day (500 to 750 Tons Per Day)</b>												
MSW Landfills		×	×				×			×		
MSW/Other Landfills		×	×	×			×			×		
Construction and Demolition Landfills					×			×	×			×
<b>680.4 to 907.2 Metric Tons Per Day (750 to 1000 Tons Per Day)</b>												
MSW Landfills				×			×					×
MSW/Other Landfills				×			×	×				×
Construction and Demolition Landfills				×	×			×				×
<b>907.2 to 2721 Metric Tons Per Day (1000 to 3000 Tons Per Day)</b>												
MSW Landfills				×				×				×
MSW/Other Landfills				×	×			×				×
Construction and Demolition Landfills				×	×			×				×
<b>2721 Plus Metric Tons Per Day (3000 PLUS Tons Per Day)</b>												
MSW Landfills				×	×	×		×				×
MSW/Other Landfills				×	×	×		×				×
Construction and Demolition Landfills				×	×	×		×				×

**B. Amount and type of cover material to be handled** — Landfill size, type, and methods of operation vary dramatically from site to site. The type of cover material utilized is important. The utilization of Alternative Daily Cover (ADC) is highly recommended to reduce the loss of valuable airspace. The current trend is for landfill managers to track cover material as closely as they do airspace and maintenance.

When discussing and working with cover material, it needs to be broken down into the three segments: daily, intermediate, and final. No matter what your requirements are, most landfill operators agree that daily cover should be no more than approx. 10-12% of the entire lift (smaller tonnage landfills might see as high as 15-18%). No matter how much is used, it is recommended, if possible, to remove the daily cover before adding new waste each day. This will benefit airspace utilization as well as gas and leachate migration. When dealing with intermediate cover or higher than normal “deck” cover, once again, it is critical to remove as much of this cover before adding any new waste (not removing this type of cover leads to a higher possibility of leachate springs and subsequent fines). Total combination of daily cover and intermediate cover if not removed, could end up totaling more than 25%-35% of your total landfill airspace utilization, which is meant for waste, not dirt.

**C. Distance cover material is to be transported** will have a large effect on cover equipment selection. Whether working with daily, intermediate, or final cover, the following economic limits or guidelines are recommended for cover material movement. The quantity of material to be moved, the time available, and possible maintenance results, must also be considered when using these guidelines.

Track-type tractor            0-61 m        (0-200 ft)

Track loader

– push and spread            0-61 m        (0-200 ft)

– load, carry, and spread 0-150 m        (0-500 ft)

(Type of material/application should be considered for excessive track wear)

Wheel loader                0-185 m        (0-600 ft)

Wheel tractor-scraper over 185 m (over 600 ft)

Articulated trucks        over 185 m (over 600 ft)

**D. Weather conditions** — when working in inclement weather, the tractive capability of a track-type machine may be necessary for poor underfoot conditions or to rip frozen cover material.

**E. Compaction requirements** — are becoming critical as extended landfill life is sought. If high density is desired, then a compactor may be necessary.

The following pages contain features, specifications and work tools for Cat Waste Handling machines. Additional information regarding drawbar pull/rimpull vs. groundspeed, controls, ground pressures, production estimating for these machines as well as specifications and performance information for Wheel Tractor Scrapers and Articulated Trucks can be found in their respective Performance Handbook sections.

## REFUSE DENSITIES

Generally, loose residential and commercial refuse weighs 150-180 kg/m<sup>3</sup> (250-300 lb/yd<sup>3</sup>). A refuse collection vehicle will increase this density to 237-415 kg/m<sup>3</sup> (400-700 lb/yd<sup>3</sup>). In-place landfill density can vary from 355-890 kg/m<sup>3</sup> (600-1500 lb/yd<sup>3</sup>), depending on the compactive effort applied to the refuse. Landfill sites that accept a high percentage of demolition waste can have densities up to 1485 kg/m<sup>3</sup> (2500 lb/yd<sup>3</sup>). Cover material will generally raise fill densities 60-120 kg/m<sup>3</sup> (100-200 lb/yd<sup>3</sup>) over the figures given above.

	Weight of Refuse	
	kg/m <sup>3</sup>	lb/yd <sup>3</sup>
Loose Refuse:	150-180	250-300
Packer Truck:	237-415	400-700
Fill Density:	355-890	600-1500
Refuse and Cover:	415-1009	700-1700

## FACTORS GOVERNING COMPACTION

Assuming equal machine weight, regardless of the type of machine, the following factors (1-4) affect compaction:

1. **Refuse Layer Thickness** — The depth of each compacted layer is perhaps the single most important controllable factor influencing density. To obtain maximum density, waste should be spread and compacted in layers **not exceeding a depth of 610 mm (2 ft)**. Thicker layers will reduce the density that a machine can develop in a given number of passes. (Density figures shown do not include cover material.)

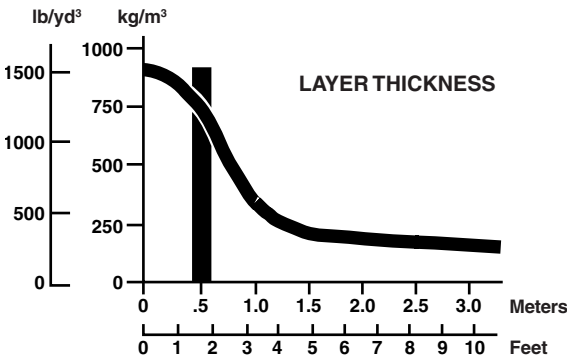

2. **Number of passes made over the refuse** also affects density. Regardless of the type of machine used, the unit should make 3-4 passes to achieve optimum density. The following graph illustrates that more than four passes result in little additional compactive effort. The added expense of additional passes is not justified by the incremental increase in density.

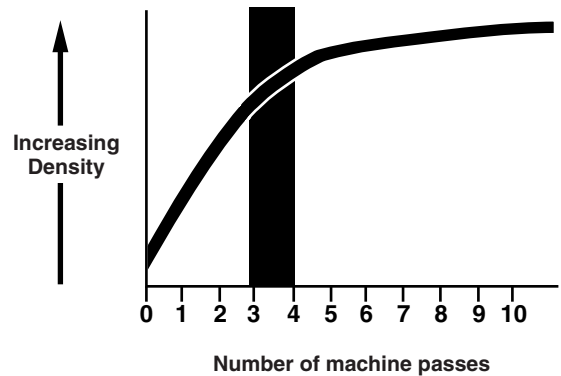

3. **Slope** — Maximum compactive effort by a track-type unit is achieved by working the waste on a slope of 3:1 or less. Track-type machines achieve higher densities by grinding and shredding the refuse into smaller pieces as they climb a slope.

Just the opposite is true for landfill compactors, the flatter the slope the better. This is because the weight of the landfill compactor is more efficiently utilized and concentrated when working on a flat surface. Landfill compactors that are used on slight slopes achieve a higher compaction density due to shearing stress that aids shredding and better blending of material.

4. **Moisture Content** — has been shown to have a significant effect on compacted density. It is believed that water tends to weaken the bridging characteristics of refuse, particularly paper such as large pieces of cardboard, etc., thereby allowing tighter consolidation. The water may also act as a lubricant — much as it does for soils. A minimum amount of moisture can increase refuse compaction density by 10%.

The optimum moisture content for maximum compaction of household refuse appears to be around 50% by weight. Field tests show actual moisture contents varying from 10-80% during dry and wet seasons. Although higher moisture content can provide higher in-place densities, the chance of leachate formation also increases.



**COMPACTION COMPARISON ESTIMATE**

The following graph may be used as a rule of thumb for the compactive ranges of various types of landfill machines if proper operating technique is employed.

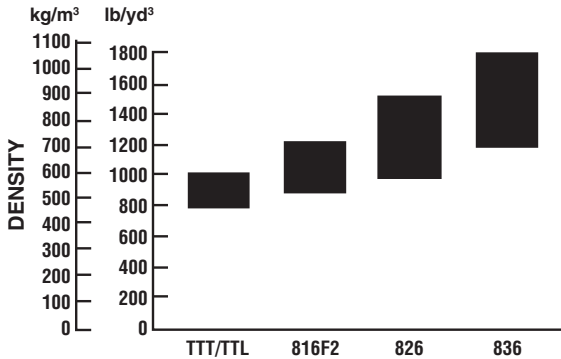

**EXAMPLE OF INCREASED COMPACTION  
ON POTENTIAL LANDFILL LIFE**

Landfill refuse capacity	1 530 000 m <sup>3</sup> ( <b>2,000,000 yd<sup>3</sup></b> )
Operating days	260
Daily volume	365 metric tons ( <b>400 tons</b> )
Yearly volume	94 328 metric tons ( <b>104,000 tons</b> )

Compaction	Landfill Life	Gain
590 kg/m <sup>3</sup> <b>1000 lb/yd<sup>3</sup></b>	9.6 years	0
710 kg/m <sup>3</sup> <b>1200 lb/yd<sup>3</sup></b>	11.5 years	1.9 years
830 kg/m <sup>3</sup> <b>1400 lb/yd<sup>3</sup></b>	13.4 years	3.8 years
950 kg/m <sup>3</sup> <b>1600 lb/yd<sup>3</sup></b>	15.3 years	5.7 years
1070 kg/m <sup>3</sup> <b>1800 lb/yd<sup>3</sup></b>	17.2 years	7.6 years

**COMPUTER AIDED EARTHMOVING  
SYSTEMS (CAES)**

The Computer Aided Earth Moving System (CAES) is a landfill management system designed for the landfill industry. CAES is designed to enable landfill personnel to maximize machine productivity and job efficiency, conserve airspace, manage cover material, improve machine utilization, collect survey data and more by combining high precision GPS technology with a wireless mobile communications system. Planning and design operations can be transmitted to the machines onboard computer, which shows the machine location relative to the design area, current surface, and final design surface, (waste and cover). Landfill operators achieve maximum compaction effectiveness by making only the necessary number of passes over the waste. Working CAESultra as a team concept with Compactors, Track-type tractors

and cover machines will increase your airspace utilization, while reducing survey time and amount of unnecessary work. Additionally, CAES permits the recording of site-specific storage areas such as hazardous waste, medical, industrial, organic, or other materials that require special handling or a geographic record of their placement. CAES provides numerous reporting and recording features allowing landfill personnel to have real time information about landfill operations enabling them to make informative operational decisions. All of this is monitored and managed in the landfill office with CAESultra Office Software.

In this example, each 120 kg (200 lb) increase in refuse density results in an additional 1.9 years of landfill life. Also this example is exclusive of cover requirements.

**COMPACTOR PRODUCTION GUIDELINES**

Model	Tons/Day		Tons/Hr	
	Metric	U.S.	Metric	U.S.
836H	1016	<b>1000</b>	127	<b>125</b>
826H	813	<b>800</b>	102	<b>100</b>
816F2	508	<b>500</b>	63.5	<b>62.5</b>

All models are pushing refuse 61 m (200 ft) spreading and making 3 to 4 passes to compact. A pass is defined as: A machine traveling over the refuse one time in one direction on flat level ground. Adverse (uphill) or favorable (downhill) grades will effect the above production figures.

- F. *Landfill method utilized* — impacts the equipment needed. The area method, which is generally suited for flat or gradual sloping surfaces will get maximum compaction effort with a compactor. The trench method may require a track loader due to its excavating and tractive capabilities.
- G. *Supplemental tasks* — should be reviewed before selecting a landfill machine. Will the machine be required for site clearing, maintaining access roads, excavating, etc.? Auxiliary duties may require additional machine capability and/or attachments. If versatility is the key consideration, a track-type machine again becomes the logical choice.
- H. *Budget* — Smaller landfill operations with limited budgets may have to consider single machine versatility ahead of specialized machines or multiple units.
- I. *Growth* — Future increases in refuse volume must be considered to properly size machines.

## LANDFILL ESTIMATING

### Example Problem #1

A professional engineer has developed a small, rural landfill master plan. The local legislative regulatory agency has approved the plan and site.

Assume:

Waste generation: 2.04 kg/day (4.5 lb/day) per person

Waste collection: 6 days/week

Topography: flat

Land availability:

area has several suitable sites at nominal price

Population served: 30,000

Projected population in 3 years: 40,000

Current daily refuse volume: ?

Type of refuse: mostly household, some commercial

Operation: propose 8 hours/day, 5½ days/week

Present equipment: none — new site

What would your comments and recommendations be on the following?:

- Probable amount of refuse generated daily?
- Type of machine for the proposed Landfill?
- Size of machine for the proposed Landfill?

### Solution

- The current incoming waste stream can be determined to be 2.04 kg/day (4.5 lb/day) per person × 30,000 people = 61.2 metric tons (67.5 tons) daily. You must now multiply that daily generation rate by 7 for the total weekly generation, and divide by the number of days that the waste is collected (6). Therefore, your waste collection per day will be (61.2 tons/day × 7 days)/6 days of collection = 71.4 metric tons (78.7 tons) collected daily.

The same equation can be used to determine the three year projected waste stream of 40,000 residents to be 81.6 metric tons (90 tons) generated daily, 95.2 metric tons (105 tons) collected each day.

- Track loader — excavating ability, single machine application based on tonnage requirements.
- 953C handle current refuse, and has extra capacity for future growth. Small compactor if additional compaction is required.

### Example Problem #2

Existing landfill has been in operation for several years.

Assume:

Type of operation: area fill

Cover material: suitable material within 90 m (300 ft)

Current daily refuse volume: 500 metric tons (550 tons)

Anticipated daily refuse volume in 3 years: 680 metric tons (750 tons)

Type of refuse: household, commercial, large amount of brush and building demolition debris

Land availability: limited, very expensive

Available Refuse Volume: 3 249 125 m<sup>3</sup> (4,250,000 yd<sup>3</sup>)

Operation: 8 hours/days, 5½ days/week

Present equipment: D8 (3 years old)

What would your comments and recommendations be on the following:

- What range of in-place densities could be expected using a track-type tractor; a Cat steel wheeled landfill compactor?
- What effect does machine selection have on site life?
- What are the advantages and limitations of steel wheeled landfill compactors?
- What are the advantages and limitations of track-type units?
- How many machines should be used on the site?
- What type should they be?
- What size should they be?

Solution

- a. The Track-Type Tractor will achieve 475 to 595 kg/m<sup>3</sup> (800 to 1000 lb/yd<sup>3</sup>) in-place density. The Cat steel wheeled landfill compactor will achieve 595 to 830 kg/m<sup>3</sup> (1000 to 1400 lb/yd<sup>3</sup>) in-place density.
- b. There are 3 249 125 m<sup>3</sup> (4,250,000 yd<sup>3</sup>) available. 500 metric tons (550 tons) per day is how many m<sup>3</sup> (yd<sup>3</sup>)? Assume a minimum density of 475 kg/m<sup>3</sup> (800 lb/yd<sup>3</sup>).

$$500 \text{ metric tons/day} \times \frac{1000 \text{ kg/metric ton}}{475 \text{ kg/m}^3} = 1052 \text{ m}^3/\text{day}$$

$$550 \text{ tons/day} \times \frac{2000 \text{ lb/ton}}{800 \text{ lb/yd}^3} = 1375 \text{ yd}^3/\text{day}$$

$$5.5 \text{ days/week} \times 52 \text{ weeks/year} = 286 \text{ days/year}$$

$$\text{Yearly volume: } 1052 \times 286 = 300\,872 \text{ m}^3$$

$$1375 \times 286 = 393,250 \text{ yd}^3$$

Landfill life at this density:

$$\frac{3\,250\,000 \text{ m}^3}{300\,872 \text{ m}^3/\text{year}} = \frac{4,250,000 \text{ yd}^3}{393,250 \text{ yd}^3/\text{year}} = 10.8 \text{ years}$$

Similar calculations are performed to generate the following tables.

500 METRIC TONS/DAY (550 TONS/DAY)			
kg/m <sup>3</sup>	Density		Landfill Life (years)
	lb/yd <sup>3</sup>		
475	800		10.8
595	1000		13.5
715	1200		16.2
835	1400		18.9
950	1600		21.6

680 METRIC TONS/DAY (750 TONS/DAY)			
kg/m <sup>3</sup>	Density		Landfill Life (years)
	lb/yd <sup>3</sup>		
475	800		7.9
595	1000		9.9
715	1200		11.9
835	1400		13.9
950	1600		15.9

From the tables we determine that a track-type tractor, at 500 metric tons per day (550 tons/day), will provide 13.5 landfill life years at 595 kg/m<sup>3</sup> (1000 lb/yd<sup>3</sup>). Compaction will extend that life 5.4 years to 18.9 years at 835 kg/m<sup>3</sup> (1400 lb/yd<sup>3</sup>).

Proper compaction techniques are necessary to achieve the higher refuse densities and increase landfill life.

- c. Advantages: Provides highest compaction densities extending landfill life.

Limitations: Specialty unit designed to spread and compact — does not excavate virgin material economically, but can handle stockpile cover material.

- d. Advantages: most versatile unit, well suited to site preparation, finishing and access road construction and maintenance; all weather machines with excellent tractive ability.

Limitation: compaction — cannot achieve the in-place refuse densities of the specialized landfill compactors.

- e. Minimum of two. Additional equipment would depend on supplemental tasks.

- f. Track-type tractor — for earthmoving and refuse spreading work; steel wheeled compactor-quantity of refuse and land cost would justify.

- g. D8 — keeping existing unit; D9 — when new tractor is necessary; 826H — with large amount of demolition debris and brush and projected increase in tonnage would justify 826H over 816F2.

**NOTE:** Ballasting the wheels on Cat Landfill Compactors to increase machine weight and achieve higher compaction densities is not recommended. Landfills are high rimpull applications. Ballasting the wheels will significantly increase machine weight but decrease overall performance when traveling on the fill. Also, wheels are not necessarily air tight or leak proof.

Cat Waste Handling Track-Type Tractor modifications are purpose built and installed at the original manufacturing facility prior to shipment.

#### Features:

- **Hinged heavy duty radiator doors** are guarded to prevent excessive trash build-up. Quick release handles allow easy access for cleaning.
- **Final drive, pivot shaft, and idler seal guarding** helps prevent wire, cable and similar material from winding around components and damaging seals.
- **Striker bars for front, rear and ripper (all optional)** keep trash from damaging fenders, fuel and hydraulic tanks or other sheet metal.
- **Lighting protection.** Front lights are mounted on top of bulldozer lift cylinders. Rear lights are ROPS mounted.
- **Waste Handling Arrangement radiator** with 6 fins/inch. (Required on D6T through D10T.)
- **Elevated sprocket** removes final drives from wear environment and eliminates impact loading for extended power train life. D7E includes D10-size bearings to ensure long life.
- **Sheet metal guarding** near track and on dozer tilt hoses.
- **Fuel tank guards** keep trash from damaging fuel and hydraulic tanks or other sheet metal.
- **Clamshell guards** — guard installed over the final drives to help prevent wire wrap. Guards include inspection plates, not available for D6N.
- **Reversible hydraulic demand fan** required for D8T, D9T, D10T, not available for D6N.
- **Heavy duty steps and grab handles** resist damage from landfill debris.
- **Center hole track shoes (optional)** help keep track clean during machine operation.
- **Blade trash racks (optional)** prevent blade spill-over and damage to cylinders or radiator guard. Increase productivity in waste handling.
- **Ducted alternator available on D6T, D7R Series 2, D8T, D9T, D10T** insures adequate current is available to maintain battery and operate accessories.
- **Elevated prescreener** to remove engine air inlet from debris environment. Larger surface area to resist plugging. Turbine precleaner is optional.
- **Cat turbine precleaner optimax dual-stage precleaner** removes large particulates from incoming air before they reach the air filter, helps extend filter life. (Optional on D6T through D10T.)
- **ROPS mounted air conditioning** helps prevent condenser core plugging. Provides full utilization of jacket water cooling system by avoiding additional heat load from radiator mounted condenser.
- **Laminated thermal shields** cover the exhaust stack inside the engine compartment, hot-side of the turbocharger, and the exhaust manifold. These shields reduce surface temperatures well below the flash point of most common combustibles encountered. (Optional on D6T through D8. Standard on D9T, D10T, not available for D6N.)
- **Chassis Guards.**
- **Sealed belly guards.**
- **Perforated engine enclosures** standard on D6T, D7E, D7R Series 2, D8T, D9T, and D10T. This configuration is unavailable when Sound Suppression is ordered.
- **Carrier rollers** not recommended on elevated sprocket machines.



MODEL	D6G Series 2 LGP WHA		D6N XL		D6N LGP	
Flywheel Power	119 kW	<b>160 hp</b>	111.8 kW	<b>150 hp</b>	111.8 kW	<b>150 hp</b>
Operating Weight (Power Shift Differential Steer)* SU Blade	18 790 kg	<b>41,425 lb</b>	—	—	—	—
Engine Model	<b>3306</b>	—	<b>C6.6 ACERT™</b>	—	<b>C6.6 ACERT</b>	—
Rated Engine RPM	<b>1900</b>	—	<b>2200</b>	—	<b>2200</b>	—
No. of Cylinders	<b>6</b>	—	<b>6</b>	—	<b>6</b>	—
Bore	121 mm	<b>4.75"</b>	105 mm	<b>4.13"</b>	105 mm	<b>4.13"</b>
Stroke	152 mm	<b>6.0"</b>	127 mm	<b>5.0"</b>	127 mm	<b>5.0"</b>
Displacement	10.5 L	<b>638 in³</b>	6.6 L	<b>403 in³</b>	6.6 L	<b>403 in³</b>
Track Rollers (Each Side)	<b>7</b>	—	<b>7</b>	—	<b>8</b>	—
Width of Standard Track Shoe	927 mm	<b>36.5"</b>	610 mm	<b>2'0"</b>	840 mm	<b>2'9"</b>
Length of Track on Ground	2.88 m	<b>9'5"</b>	2581 mm	<b>8'6"</b>	3117 mm	<b>10'3"</b>
Ground Contact Area (with Std. Shoe)	5.34 m²	<b>8276 in²</b>	3.15 m²	<b>4882 in²</b>	5.24 m²	<b>8122 in²</b>
Track Gauge	2.11 m	<b>6'11"</b>	1.89 m	<b>6'2"</b>	2.16 m	<b>7'1"</b>
GENERAL DIMENSIONS:						
Height (Stripped Top)**	2.18 m	<b>7'2"</b>	—	—	—	—
Height (To Top of ROPS Canopy)	3.21 m	<b>10'6"</b>	3.04 m	<b>10'0"</b>	3.14 m	<b>10'4"</b>
Height (To Top of ROPS Cab)	3.21 m	<b>10'6"</b>	3.10 m	<b>10'2"</b>	3.20 m	<b>10'6"</b>
Overall Length (without Blade)	3.94 m	<b>12'11"</b>	3.74 m	<b>12'3"</b>	4.17 m	<b>13'8"</b>
with S Blade	5.20 m	<b>17'1"</b>	—	—	—	—
with SU Blade	—	—	5.16 m	<b>16'11"</b>	—	—
with VPAT Blade	—	—	4.90 m	<b>16'1"</b>	5.37 m	<b>17'7"</b>
Width (Over Trunnion)	3.24 m	<b>10'8"</b>	2.63 m	<b>8'8"</b>	—	—
Width (without Trunnion — Std. Track)	3.03 m	<b>9'11"</b>	2.50 m	<b>8'2"</b>	—	—
Ground Clearance	310 mm	<b>12.2"</b>	394 mm	<b>1'4"</b>	507 mm	<b>1'8"</b>
Blade Types and Widths:						
Straight	3.70 m	<b>12'2"</b>	—	—	—	—
Semi-U	—	—	3.19 m	<b>10'6"</b>	—	—
VPAT (Variable pitch, angle, and tilt) straight	—	—	3.27 m	<b>10'9"</b>	4.08 m	<b>13'5"</b>
Fuel Tank Refill Capacity	320 L	<b>84 U.S. gal</b>	299 L	<b>79 U.S. gal</b>	299 L	<b>79 U.S. gal</b>

\* Operating Weight for the D6G Series 2 LGP WHA includes non-ROPS cab, operator, lubricants, coolant, full fuel tank, hydraulic controls and fluid, straight dozer with tilt, horn, back-up alarm, retrieval hitch and front pull hook.

Operating Weight for the D6N XL and D6N LGP includes ROPS canopy, operator, lubricants, coolant, full fuel tank, hydraulic controls and fluid, straight dozer with tilt, horn, back-up alarm, retrieval hitch and front pull hook.

\*\* Height (stripped top) — without ROPS canopy, exhaust, precleaner, seat back or other easily removed encumbrances.



MODEL	D6T XL		D6T XW		D6T LGP	
Engine Emissions Tier	Tier 4 Interim/Stage IIIB		Tier 4 Interim/Stage IIIB		Tier 4 Interim/Stage IIIB	
Flywheel Power	149 kW	200 hp	149 kW	200 hp	149 kW	200 hp
Operating Weight* Power Shift Differential Steer	20 679 kg	45,590 lb	21,531 kg	47,468 lb	22,270 kg	49,096 lb
Engine Model	C9.3 ACERT		C9.3 ACERT		C9.3 ACERT	
Advertised Engine RPM	1850		1850		1850	
No. of Cylinders	6		6		6	
Bore	115 mm	4.5"	115 mm	4.5"	115 mm	4.5"
Stroke	149 mm	5.9"	149 mm	5.9"	149 mm	5.9"
Displacement	9.3 L	567 in <sup>3</sup>	9.3 L	567 in <sup>3</sup>	9.3 L	567 in <sup>3</sup>
Track Rollers (Each Side)	7		7		8	
Width of Standard Track Shoe	560 mm	22"	760 mm	30"	915 mm	36"
VPAT	560 mm	22"	710 mm	28"	785 mm	31"
Length of Track on Ground	2.84 m	9'4"	2.84 m	9'4"	3.25 m	10'8"
Ground Contact Area (w/Std.Shoe)	3.18 m <sup>2</sup>	4929 in <sup>2</sup>	4.31 m <sup>2</sup>	6681 in <sup>2</sup>	5.95 m <sup>2</sup>	9223 in <sup>2</sup>
VPAT	3.18 m <sup>2</sup>	4929 in <sup>2</sup>	4.03 m <sup>2</sup>	6247 in <sup>2</sup>	5.10 m <sup>2</sup>	7905 in <sup>2</sup>
Track Gauge	1.88 m	74"	2.03 m	80"	2.29 m	90"
VPAT	2.13 m	84"	2.29 m	90"	2.29 m	90"
GENERAL DIMENSIONS:						
Height** (Stripped Top***)	2.44 m	8'0"	2.44 m	8'0"	2.45 m	8'0"
Height** (To Top of ROPS Canopy)	3.11 m	10'2"	3.11 m	10'2"	3.16 m	10'5"
Height** (To Top of ROPS Cab)	3.15 m	10'4"	3.15 m	10'4"	3.15 m	10'4"
Overall Length (without Blade)	3.88 m	12'9"	3.88 m	12'9"	4.22 m	13'10"
with S Blade	—	—	—	—	5.43 m	17'10"
with SU Blade	5.34 m	17'6"	5.35 m	17'7"	—	—
with VPAT Blade	5.10 m	16'9"	5.37 m	17'7"	5.97 m	19'7"
with Angle Blade	5.22 m	17'2"	5.28 m	17'4"	5.80 m	19'0"
Width (Over Trunnion)	2.64 m	8'8"	2.95 m	9'8"	3.43 m	8'8"
Width (without Trunnion — Std. Track)	2.44 m	8'0"	2.79 m	9'2"	3.20 m	10'6"
Ground Clearance**	384 mm	1'3"	384 mm	1'3"	434 mm	1'5"
Blade Types and Widths:						
Straight	4.16 m	13'8"	4.52 m	14'10"	5.07 m	16'8"
Angle Straight	3.80 m	12'6"	4.13 m	13'7"	4.78 m	15'8"
Full 25° Angle	3.26 m	10'8"	3.57 m	11'9"	—	—
Semi-U	3.88 m	12'9"	4.16 m	13'8"	4.16 m	13'8"
VPAT Straight	3.54 m	11'7"	3.80 m	12'6"	3.80 m	12'6"
Fuel Tank Refill Capacity	425 L	112 U.S. gal	425 L	112 U.S. gal	425 L	112 U.S. gal

\*Operating Weight includes cab, operator, lubricants, coolant, full fuel tank, standard track, hydraulic controls and fluid, SU blade and drawbar.

\*\*Dimensions measured from ground line. Add grouser height for total dimension on hard surfaces.

\*\*\*Height (stripped top) — without ROPS canopy, exhaust, seat back or other easily removed encumbrances.



MODEL	D6T WHA		D6T XL WHA		D6T XW WHA		D6T LGP WHA	
Flywheel Power	138 kW	<b>185 hp</b>	149 kW	<b>200 hp</b>	149 kW	<b>200 hp</b>	149 kW	<b>200 hp</b>
Operating Weight (Power Shift Differential Steer)* SU Blade	18 393 kg	<b>40,550 lb</b>	20 148 kg	<b>44,420 lb</b>	20 739 kg	<b>45,723 lb</b>	21 783 kg	<b>48,024 lb</b>
Engine Model	<b>C9 ACERT</b>		<b>C9 ACERT</b>		<b>C9 ACERT</b>		<b>C9 ACERT</b>	
Rated Engine RPM	<b>1850</b>		<b>1850</b>		<b>1850</b>		<b>1850</b>	
No. of Cylinders	<b>6</b>		<b>6</b>		<b>6</b>		<b>6</b>	
Bore	112 mm	<b>4.4"</b>	112 mm	<b>4.4"</b>	112 mm	<b>4.4"</b>	112 mm	<b>4.4"</b>
Stroke	149 mm	<b>5.9"</b>	149 mm	<b>5.9"</b>	149 mm	<b>5.9"</b>	149 mm	<b>5.9"</b>
Displacement	8.8 L	<b>537 in<sup>3</sup></b>	8.8 L	<b>537 in<sup>3</sup></b>	8.8 L	<b>537 in<sup>3</sup></b>	8.8 L	<b>537 in<sup>3</sup></b>
Track Rollers (Each Side)	<b>6</b>		<b>7</b>		<b>7</b>		<b>8</b>	
Width of Standard Track Shoe:	560 mm	<b>1'10"</b>	560 mm	<b>1'10"</b>	760 mm	<b>2'6"</b>	915 mm	<b>3'0"</b>
VPAT	—		560 mm	<b>1'10"</b>	760 mm	<b>2'6"</b>	810 mm	<b>2'10"</b>
Length of Track on Ground	2.67 m	<b>8'9"</b>	2.87 m	<b>9'5"</b>	2.87 m	<b>9'5"</b>	3.28 m	<b>10'9"</b>
Ground Contact Area (with Std. Shoe)	2.98 m <sup>2</sup>	<b>4620 in<sup>2</sup></b>	3.22 m <sup>2</sup>	<b>4972 in<sup>2</sup></b>	4.36 m <sup>2</sup>	<b>6780 in<sup>2</sup></b>	5.99 m <sup>2</sup>	<b>9288 in<sup>2</sup></b>
VPAT	—		3.22 m <sup>2</sup>	<b>4972 in<sup>2</sup></b>	4.36 m <sup>2</sup>	<b>6780 in<sup>2</sup></b>	5.31 m <sup>2</sup>	<b>8256 in<sup>2</sup></b>
Track Gauge	1.88 m	<b>6'2"</b>	1.88 m	<b>6'2"</b>	2.03 m	<b>6'8"</b>	2.29 m	<b>7'6"</b>
VPAT	—		2.13 m	<b>7'0"</b>	2.29 m	<b>7'6"</b>	2.29 m	<b>7'6"</b>
GENERAL DIMENSIONS:								
Height (Stripped Top)**	2.38 m	<b>7'10"</b>	2.38 m	<b>7'10"</b>	2.38 m	<b>7'10"</b>	2.43 m	<b>8'0"</b>
Height (To Top of ROPS Canopy)	3.20 m	<b>10'6"</b>	3.20 m	<b>10'6"</b>	3.20 m	<b>10'6"</b>	3.25 m	<b>10'8"</b>
Height (To Top of ROPS Cab)	3.19 m	<b>10'5"</b>	3.20 m	<b>10'6"</b>	3.20 m	<b>10'6"</b>	3.25 m	<b>10'8"</b>
Overall Length (without Blade)	3.86 m	<b>12'8"</b>	3.86 m	<b>12'8"</b>	3.86 m	<b>12'8"</b>	4.25 m	<b>13'11"</b>
with S Blade	4.90 m	<b>16'1"</b>	—		—		5.47 m	<b>17'11"</b>
with SU Blade	5.10 m	<b>16'9"</b>	5.33 m	<b>17'6"</b>	5.33 m	<b>17'6"</b>	—	
with VPAT Blade	—		5.27 m	<b>17'4"</b>	5.27 m	<b>17'4"</b>	5.97 m	<b>19'7"</b>
with Angle Blade	5.01 m	<b>16'5"</b>	5.21 m	<b>17'1"</b>	5.21 m	<b>17'1"</b>	—	
Overall Length (VPAT)	—		3.86 m	<b>12'8"</b>	3.86 m	<b>12'8"</b>	4.25 m	<b>13'11"</b>
with S Blade	—		—		—		5.47 m	<b>17'11"</b>
with SU Blade	—		5.33 m	<b>17'6"</b>	5.33 m	<b>17'6"</b>	—	
with VPAT Blade	—		5.27 m	<b>17'4"</b>	5.27 m	<b>17'4"</b>	5.97 m	<b>19'7"</b>
with Angle Blade	—		5.21 m	<b>17'1"</b>	5.21 m	<b>17'1"</b>	—	
Width (Over Trunnion)	2.64 m	<b>8'8"</b>	2.64 m	<b>8'8"</b>	2.95 m	<b>9'8"</b>	3.43 m	<b>8'8"</b>
Width (without Trunnion — Std. Track)	2.44 m	<b>8'0"</b>	2.44 m	<b>8'0"</b>	2.74 m	<b>9'0"</b>	3.15 m	<b>10'4"</b>
Ground Clearance	383 mm	<b>1'3"</b>	383 mm	<b>1'3"</b>	383 mm	<b>1'3"</b>	433 mm	<b>1'5"</b>
Blade Types and Widths:								
Straight	3.36 m	<b>11'0"</b>	—		—		4.06 m	<b>13'4"</b>
Angle Straight	4.17 m	<b>13'8"</b>	4.17 m	<b>13'8"</b>	4.20 m	<b>13'9"</b>	—	
Full 25° Angle	3.78 m	<b>12'5"</b>	3.78 m	<b>12'5"</b>	3.81 m	<b>12'6"</b>	—	
Semi-U	3.26 m	<b>10'8"</b>	3.26 m	<b>10'8"</b>	3.56 m	<b>11'8"</b>	—	
VPAT (Variable pitch, angle, and tilt) straight	—		3.88 m	<b>12'9"</b>	4.16 m	<b>13'8"</b>	4.16 m	<b>13'8"</b>
VPAT Full 25° Angle	—		3.55 m	<b>11'8"</b>	3.81 m	<b>12'6"</b>	3.81 m	<b>12'6"</b>
Fuel Tank Refill Capacity	424 L	<b>112 U.S. gal</b>	424 L	<b>112 U.S. gal</b>	424 L	<b>112 U.S. gal</b>	424 L	<b>112 U.S. gal</b>

\* Operating Weight includes ROPS canopy, operator, lubricants, coolant, full fuel tank, hydraulic controls and fluid, straight dozer with tilt, horn, back-up alarm, retrieval hitch and front pull hook.

\*\* Height (stripped top) — without ROPS canopy, exhaust, pre-cleaner, seat back or other easily removed encumbrances.



MODEL	D7E		D7E LGP		D7E		D7E LGP	
Engine Emissions Tier	—		—		Tier 4 Interim/ Stage IIIB		Tier 4 Interim/ Stage IIIB	
Flywheel Power	175 kW	<b>235 hp</b>	175 kW	<b>235 hp</b>	—		—	
Advertised Flywheel Power	—		—		175 kW	<b>235 hp</b>	175 kW	<b>235 hp</b>
Operating Weight:* Electric Drive Differential Steer	25 700 kg	<b>56,669 lb</b>	28 170 kg	<b>62,115 lb</b>	25 996 kg	<b>57,310 lb</b>	28 465 kg	<b>62,755 lb</b>
Engine Model	<b>C9.3</b>		<b>C9.3</b>		<b>C9.3</b>		<b>C9.3</b>	
Rated Engine RPM	<b>1700</b>		<b>1700</b>		—		—	
Advertised Engine RPM	—		—		<b>1700</b>		<b>1700</b>	
No. of Cylinders	<b>6</b>		<b>6</b>		<b>6</b>		<b>6</b>	
Bore	115 mm	<b>4.5"</b>	115 mm	<b>4.5"</b>	115 mm	<b>4.5"</b>	115 mm	<b>4.5"</b>
Stroke	149 mm	<b>5.9"</b>	149 mm	<b>5.9"</b>	149 mm	<b>5.9"</b>	149 mm	<b>5.9"</b>
Displacement	9.3 L	<b>567 in³</b>	9.3 L	<b>567 in³</b>	9.3 L	<b>567 in³</b>	9.3 L	<b>567 in³</b>
Track Rollers (Each Side)	<b>7</b>		<b>8</b>		<b>7</b>		<b>8</b>	
Width of Standard Track Shoe	610 mm	<b>24"</b>	915 mm	<b>36"</b>	610 mm	<b>24"</b>	915 mm	<b>36"</b>
Length of Track on Ground	3.02 m	<b>9'11"</b>	3.45 m	<b>11'4"</b>	3.02 m	<b>9'11"</b>	3.45 m	<b>11'4"</b>
Ground Contact Area (w/Std. Shoe)	3.68 m²	<b>5698 in²</b>	6.31 m²	<b>9792 in²</b>	3.68 m²	<b>5698 in²</b>	6.31 m²	<b>9792 in²</b>
Track Gauge	1.98 m	<b>6'6"</b>	2.29 m	<b>7'6"</b>	1.98 m	<b>6'6"</b>	2.29 m	<b>7'6"</b>
GENERAL DIMENSIONS:								
Height** (To Top of ROPS Cab)	3.32 m	<b>10'11"</b>	3.32 m	<b>10'11"</b>	3.32 m	<b>10'11"</b>	3.32 m	<b>10'11"</b>
Overall Length (without Blade)	4.88 m	<b>16'0"</b>	4.88 m	<b>16'0"</b>	4.88 m	<b>16'0"</b>	4.88 m	<b>16'0"</b>
with S Blade	5.86 m	<b>19'3"</b>	5.56 m	<b>18'3"</b>	5.86 m	<b>19'3"</b>	5.56 m	<b>18'3"</b>
with SU Blade	6.07 m	<b>19'11"</b>	—	—	6.07 m	<b>19'11"</b>	—	—
Width (Over Trunnion)	2.88 m	<b>9'5"</b>	3.42 m	<b>11'3"</b>	2.88 m	<b>9'5"</b>	3.42 m	<b>11'3"</b>
Width (without Trunnion — Std. Shoe)	2.59 m	<b>8'6"</b>	3.2 m	<b>10'6"</b>	2.59 m	<b>8'6"</b>	3.2 m	<b>10'6"</b>
Ground Clearance	472 mm	<b>18.6"</b>	472 mm	<b>18.6"</b>	472 mm	<b>18.6"</b>	472 mm	<b>18.6"</b>
Blade Types and Widths:								
Straight	3.9 m	<b>12'10"</b>	4.54 m	<b>14'11"</b>	3.9 m	<b>12'10"</b>	4.54 m	<b>14'11"</b>
Angle Straight	4.5 m	<b>14'9"</b>	—	—	4.5 m	<b>14'9"</b>	—	—
Full 25° Angle	4.12 m	<b>13'6"</b>	—	—	4.12 m	<b>13'6"</b>	—	—
Universal	3.99 m	<b>13'1"</b>	—	—	3.99 m	<b>13'1"</b>	—	—
Semi-U	3.71 m	<b>12'2"</b>	—	—	3.71 m	<b>12'2"</b>	—	—
Fuel Tank Refill Capacity	409 L	<b>108 U.S.gal</b>	409 L	<b>108 U.S.gal</b>	409 L	<b>108 U.S.gal</b>	409 L	<b>108 U.S.gal</b>

\*Operating Weight includes cab, operator, lubricants, coolant, full fuel tank, standard track, hydraulic controls and fluid, SU blade and drawbar.

\*\*Dimensions measured from ground line. Add grouser height for total dimension on hard surfaces.



# Waste Handling Track-Type Tractors

## Specifications



MODEL	D7R Series 2 WHA		D7R XR Series 2 WHA		D7R LGP Series 2 WHA		D8R WHA	
	Flywheel Power	179 kW	<b>240 hp</b>	179 kW	<b>240 hp</b>	179 kW	<b>240 hp</b>	228 kW
Operating Weight* Power Shift Differential Steer	28 108 kg	<b>61,912 lb</b>	28 764 kg	<b>63,357 lb</b>	30 328 kg	<b>66,802 lb</b>	37 630 kg	<b>82,880 lb</b>
Engine Model	<b>3176C SCAC</b>		<b>3176C SCAC</b>		<b>3176C SCAC</b>		<b>3406E TA</b>	
Rated Engine RPM	<b>2100</b>		<b>2100</b>		<b>2100</b>		<b>2100</b>	
No. of Cylinders	<b>6</b>		<b>6</b>		<b>6</b>		<b>6</b>	
Bore	125 mm	<b>4.92"</b>	125 mm	<b>4.92"</b>	125 mm	<b>4.92"</b>	137 mm	<b>5.4"</b>
Stroke	140 mm	<b>5.5"</b>	140 mm	<b>5.5"</b>	140 mm	<b>5.5"</b>	165 mm	<b>6.5"</b>
Displacement	10.3 L	<b>629 in<sup>3</sup></b>	10.3 L	<b>629 in<sup>3</sup></b>	10.3 L	<b>629 in<sup>3</sup></b>	14.6 L	<b>893 in<sup>3</sup></b>
Track Rollers (Each Side)	<b>7</b>		<b>8</b>		<b>7</b>		<b>8</b>	
ERF†	—		—		<b>9</b>		—	
Width of Standard Track Shoe	560 mm	<b>1'10"</b>	610 mm	<b>2'0"</b>	914 mm	<b>3'0"</b>	560 mm	<b>1'10"</b>
Length of Track on Ground	2.89 m	<b>9'5"</b>	3.05 m	<b>10'0"</b>	3.16 m	<b>10'5"</b>	3.21 m	<b>10'6"</b>
Ground Contact Area (w/Std. Shoe)	3.22 m <sup>2</sup>	<b>4996 in<sup>2</sup></b>	3.72 m <sup>2</sup>	<b>5768 in<sup>2</sup></b>	5.78 m <sup>2</sup>	<b>8960 in<sup>2</sup></b>	3.57 m <sup>2</sup>	<b>5544 in<sup>2</sup></b>
Track Gauge	1.98 m	<b>6'6"</b>	1.98 m	<b>6'6"</b>	2.24 m	<b>7'4"</b>	2.08 m	<b>6'10"</b>
GENERAL DIMENSIONS:								
Height (Stripped Top)**	2.56 m	<b>8'5"</b>	2.56 m	<b>8'5"</b>	2.74 m	<b>9'0"</b>	2.67 m	<b>8'9"</b>
Height (To Top of ROPS Canopy)	3.53 m	<b>11'7"</b>	3.53 m	<b>11'7"</b>	3.52 m	<b>11'6"</b>	3.51 m	<b>11'6"</b>
Height (To Top of ROPS Cab)	3.43 m	<b>11'2"</b>	3.43 m	<b>11'2"</b>	3.58 m	<b>11'9"</b>	3.45 m	<b>11'3"</b>
Overall Length (with SU Blade)***	—	—	—	—	—	—	6.91 m	<b>22'8"</b>
(without Blade)	—	—	—	—	—	—	4.93 m	<b>16'2"</b>
Overall Length (with S Blade)	5.69 m	<b>18'8"</b>	5.81 m	<b>19'1"</b>	5.78 m	<b>19'0"</b>	—	—
(without Blade)	4.67 m	<b>15'4"</b>	4.67 m	<b>15'4"</b>	4.67 m	<b>15'4"</b>	—	—
Width (Over Trunnion)	2.87 m	<b>9'5"</b>	2.87 m	<b>9'5"</b>	3.37 m	<b>11'1"</b>	3.05 m	<b>10'0"</b>
Width (without Trunnion — Std. Shoe)	2.54 m	<b>8'4"</b>	2.59 m	<b>8'6"</b>	3.15 m	<b>10'4"</b>	2.70 m	<b>8'8"</b>
Ground Clearance	414 mm	<b>16.3"</b>	414 mm	<b>16.3"</b>	496 mm	<b>1'7.5"</b>	606 mm	<b>1'11"</b>
Blade Types and Widths:								
Straight	3.52 m	<b>11'7"</b>	3.32 m	<b>11'7"</b>	4.55 m	<b>14'11"</b>	—	—
Angle Straight	4.50 m	<b>14'9"</b>	4.50 m	<b>14'9"</b>	—	—	4.99 m	<b>16'4"</b>
Full 25° Angle	4.12 m	<b>13'6"</b>	4.12 m	<b>13'6"</b>	—	—	4.52 m	<b>14'10"</b>
Universal	3.98 m	<b>13'1"</b>	3.98 m	<b>13'1"</b>	—	—	4.26 m	<b>14'0"</b>
Semi-U	3.69 m	<b>12'2"</b>	3.69 m	<b>12'2"</b>	—	—	3.94 m	<b>12'11"</b>
Fuel Tank Refill Capacity	479 L	<b>127 U.S. gal</b>	479 L	<b>127 U.S. gal</b>	479 L	<b>127 U.S. gal</b>	625 L	<b>165 U.S. gal</b>

\* Operating Weight includes ROPS canopy, operator, lubricants, coolant, full fuel tank, hydraulic controls and fluid, straight dozer with tilt, horn, back-up alarm, retrieval hitch and front pull hook.

— D8R equipped with track guides, ROPS/FOPS cab, single shank ripper and SU blade.

\*\* Height (stripped top) — without ROPS canopy, exhaust, seat back or other easily removed encumbrances.

\*\*\* Includes drawbar.

† ERF — Extended Track Roller Frame. Extends frame 366 mm (14.4"), adds 3 track sections and 2 rollers/side.

## Blade Specifications

## Waste Handling Track-Type Tractors



MODEL	D8T WHA		D9T WHA		D10T WHA	
Flywheel Power	231 kW	310 hp	306 kW	410 hp	433 kW	580 hp
Operating Weight:* Power Shift Differential Steer	—		—		65 764 kg	144,986 lb
Engine Model	C15 ACERT		C18 ACERT		C27 ACERT	
Rated Engine RPM	1850		1800		1800	
No. of Cylinders	6		8		12	
Bore	137 mm	5.4"	145 mm	5.7"	137 mm	5.4"
Stroke	172 mm	6.75"	183 mm	7.2"	152 mm	6"
Displacement	15.2 L	928 in <sup>3</sup>	18.1 L	1106 in <sup>3</sup>	27 L	1649 in <sup>3</sup>
Track Rollers (Each Side)	8		8		8	
Width of Standard Track Shoe	560 mm	1'10"	610 mm	2'0"	610 mm	2'0"
Length of Track on Ground	3.21 m	10'6"	3.47 m	11'5"	3.88 m	12'9"
Ground Contact Area (w/Std. Shoe)	3.58 m <sup>2</sup>	5544 in <sup>2</sup>	4.24 m <sup>2</sup>	6569 in <sup>2</sup>	4.74 m <sup>2</sup>	7347 in <sup>2</sup>
Track Gauge	2.08 m	6'10"	2.25 m	7'5"	2.55 m	8'4"
GENERAL DIMENSIONS:						
Height (Stripped Top)**	2.67 m	8'9"	3.00 m	9'10"	3.22 m	10'7"
Height (To Top of ROPS Canopy)	3.46 m	11'4"	3.99 m	13'1"	4.34 m	14'3"
Height (To Top of ROPS Cab)	3.46 m	11'4"	3.82 m	12'6"	4.07 m	13'4"
Overall Length (with Blade and Ripper) (without Blade and Ripper)	—		—		9.26 m	30'5"
	—		—		5.33 m	17'6"
Overall Length (with SU Blade)*** (without Blade)	6.09 m	20'0"	6.63 m	21'10"	7.50 m	24'8"
	4.64 m	15'2"	4.91 m	16'1"	5.33 m	17'6"
Width (Over Trunnion)	3.05 m	10'0"	3.30 m	10'10"	3.72 m	12'2"
Width (without Trunnion — Std. Shoe)	2.64 m	8'8"	2.87 m	9'5"	3.16 m	10'4"
Ground Clearance	618 mm	2'0"	596 mm	1'11"■	615 mm	2'0"
Blade Types and Widths:						
Angle Straight	4.99 m	16'4"	—		—	
Full 25° Angle	4.52 m	14'10"	—		—	
Universal	4.26 m	14'0"	4.65 m	15'3"	5.26 m	17'3"
Semi-U	3.94 m	12'11"	4.31 m	14'2"	—	
Fuel Tank Refill Capacity	643 L	170 U.S. gal	889 L	235 U.S. gal	1109 L	293 U.S. gal

\* Operating Weight includes ROPS canopy, operator, lubricants, coolant, full fuel tank, hydraulic controls and fluids, semi universal blade with tilt, back-up alarm, seat belts, lights, rigid drawbar and front towing device.

— D8T and D9T equipped with track guides, ROPS/FOPS cab, single shank ripper and SU blade.

— D10T includes 10 SU blade single shank ripper and ROPS cab.

\*\* Height (stripped top) — without ROPS canopy, exhaust, seat back or other easily removed encumbrances.

\*\*\* Includes drawbar.

■ SAE J1234.

MODEL	D6G Series 2 LGP		D6T, D6T XL and D6T LGP			
	6S LGP		6SU		6SU XL	
Type	Straight		Semi Universal		Semi Universal	
Blade Capacities w/Trash Rack*	8.18 m <sup>3</sup>	10.7 yd <sup>3</sup>	11.2 m <sup>3</sup>	14.3 yd <sup>3</sup>	11.2 m <sup>3</sup>	14.3 yd <sup>3</sup>
Weight, Shipping** (Dozer)	2758 kg	6080 lb	3026 kg	6657 lb	3026 kg	6657 lb
Tractor and Dozer Dimensions:						
A Length (Blade Straight)	5.20 m	17'1"	5.31 m	17'5"	5.55 m	18'2"
Blade Dimensions:						
B Width (including std. end bits)	3.70 m	12'2"	3.26 m	10'8"	3.26 m	10'8"
C Height	1.7 m	5'7"	2019 mm	6'7"	2019 mm	6'7"
D Max. Digging Depth	494 mm	19.5"	473 mm	18.6"	459 mm	18.1"
E Ground Clearance @ Full Lift	1089 mm	3'6.9"	1104 mm	3'7.5"	1195 mm	3'11.1"
F Manual Tilt	697 mm	2'3.4"	670 mm	2'2.4"	670 mm	2'2.4"
G Max. Pitch	—		+5.3°–4.8°		+5.3°–4.8°	
H Max. Hydraulic Tilt	857 mm	2'9.7"	743 mm	2'5.3"	743 mm	2'5.3"
J Hydraulic Tilt (Manual Brace Centered)	367 mm	14.4"	408 mm	16.1"	408 mm	16.1"

\* Blade capacities as determined by SAE J1265.

Notice that the capacity of the U-blade is the volume carried by a straight blade of the same dimensions plus the volume included in the "cup" of the U-blade. It is intended for **relative comparisons of dozer sizes**, and not for predicting capacities or productivities in actual field conditions.

\*\* Shipping Weight — Total Bulldozer Arrangement includes: Blade, push arms or C-frame, braces, cylinders, lines, trunnions and lift cylinder mountings.

MODEL	D6T, D6T XL and D6T LGP			
	6S LGP		6SU XW	
Type	Straight		Semi Universal	
Blade Capacities*	9.4 m <sup>3</sup>	12.3 yd <sup>3</sup>	11.2 m <sup>3</sup>	14.3 yd <sup>3</sup>
Weight, Shipping** (Dozer)	2840 kg	6262 lb	3026 kg	6657 lb
Tractor and Dozer Dimensions:				
A Length (Blade Straight)	5.71 m	18'9"	—	
Blade Dimensions:				
B Width (including std. end bits)	4.04 m	13'3"	3.56 m	11'8"
C Height	1101 mm	3'7.3"	2019 mm	6'7"
D Max. Digging Depth	655 mm	2'1.2"	459 mm	18.1"
E Ground Clearance @ Full Lift	1083 mm	3'6.6"	1195 mm	3'11"
F Manual Tilt	632 mm	2'0.9"	670 mm	2'2.4"
G Max. Pitch	+5.3°–4.8°		+5.3°–4.8°	
H Max. Hydraulic Tilt	701 mm	2'3.6"	743 mm	2'5.3"
J Hydraulic Tilt (Manual Brace Centered)	385 mm	15.2"	743 mm	2'5.3"

\* Blade capacities as determined by SAE J1265.

Notice that the capacity of the U-blade is the volume carried by a straight blade of the same dimensions plus the volume included in the "cup" of the U-blade. It is intended for **relative comparisons of dozer sizes**, and not for predicting capacities or productivities in actual field conditions.

\*\* Shipping Weight — Total Bulldozer Arrangement includes: Blade, push arms or C-frame, braces, cylinders, lines, trunnions and lift cylinder mountings.

MODEL	D7R Series 2 and D7R LGP Series 2			
	7S		7SU	
Type	Straight		Semi Universal	
Blade Capacities*	10.9 m <sup>3</sup>	14.2 yd <sup>3</sup>	14.0 m <sup>3</sup>	18.4 yd <sup>3</sup>
Weight, Shipping** (Dozer)	4028 kg	8861 lb	4083 kg	8982 lb
Tractor and Dozer Dimensions:				
A Length (Blade Straight)	5.81 m	19'1"	6.03 m	19'9"
Blade Dimensions:				
B Width (including std. end bits)	3.90 m	12'10"	3.69 m	12'1"
C Height	1971 mm	6'6"	2133 mm	7'0"
D Max. Digging Depth	527 mm	1'8.7"	527 mm	1'8.7"
E Ground Clearance @ Full Lift	1145 mm	3'9.1"	1145 mm	3'9.1"
G Max. Pitch Adjustment	+3.1°–3.9°		+3.1°–3.9°	
H Max. Hydraulic Tilt	845 mm	2'9.3"	799 mm	2'7.4"
J Hydraulic Tilt (Manual Brace Centered)	501 mm	1'7.7"	474 mm	18.6"

\* Blade capacities as determined by SAE J1265.

Notice that the capacity of the U-blade is the volume carried by a straight blade of the same dimensions plus the volume included in the "cup" of the U-blade. It is intended for **relative comparisons of dozer sizes**, and not for predicting capacities or productivities in actual field conditions.

\*\* Shipping Weight — Total Bulldozer Arrangement includes: Blade, push arms or C-frame, braces, cylinders, lines, trunnions and lift cylinder mountings.

25

MODEL	D7R Series 2 and D7R LGP Series 2			
	7U		7S LGP	
Type	Universal		Straight	
Blade Capacities*	16.8 m <sup>3</sup>	22 yd <sup>3</sup>	12.3 m <sup>3</sup>	16.1 yd <sup>3</sup>
Weight, Shipping** (Dozer)	4402 kg	9684 lb	4113 kg	9061 lb
Tractor and Dozer Dimensions:				
A Length (Blade Straight)	6.27 m	20'7"	5.81 m	19'1"
Blade Dimensions:				
B Width (including std. end bits)	3.98 m	13'1"	4.50 m	14'9"
C Height	2162 mm	7'1"	1971 mm	6'6"
D Max. Digging Depth	527 mm	1'8.7"	668 mm	2'2.3"
E Ground Clearance @ Full Lift	1145 mm	3'9.1"	1153 mm	3'9.4"
G Max. Pitch Adjustment	+3.1°–3.9°		+3.0°–3.9°	
H Max. Hydraulic Tilt	861 mm	2'9.9"	686 mm	2'3"
J Hydraulic Tilt (Manual Brace Centered)	511 mm	1'8.1"	426 mm	16.8"

\* Blade capacities as determined by SAE J1265.

Notice that the capacity of the U-blade is the volume carried by a straight blade of the same dimensions plus the volume included in the "cup" of the U-blade. It is intended for **relative comparisons of dozer sizes**, and not for predicting capacities or productivities in actual field conditions.

\*\* Shipping Weight — Total Bulldozer Arrangement includes: Blade, push arms or C-frame, braces, cylinders, lines, trunnions and lift cylinder mountings.

<b>MODEL</b>	<b>D8T WHA</b>					
	<b>8SU</b>		<b>8U</b>		<b>8SU LGP</b>	
Type						
Blade Capacities*	20 m <sup>3</sup>	<b>26.1 yd<sup>3</sup></b>	24.8 m <sup>3</sup>	<b>32.4 yd<sup>3</sup></b>	21.1 m <sup>3</sup>	<b>27.6 yd<sup>3</sup></b>
Dozer Weight**	5466 kg	<b>12,025 lb</b>	6313 kg	<b>13,888 lb</b>	5624 kg	<b>12,400 lb</b>
Tractor and Dozer Dimensions:						
Length Blade Straight	6.39 m	<b>21'0"</b>	6.79 m	<b>22'3"</b>	6.39 m	<b>21'0"</b>
Blade Dimensions:						
Width including std. end bits	3.94 m	<b>12'11"</b>	4.26 m	<b>14'0"</b>	4.52 m	<b>14'10"</b>
Height	2464 mm	<b>8'1"</b>	2515 mm	<b>8'3"</b>	2465 mm	<b>8'1"</b>
Maximum Dig Depth	582 mm	<b>1'10.9"</b>	582 mm	<b>1'10.9"</b>	582 mm	<b>1'10.9"</b>
Ground Clearance at full raise	1231 mm	<b>4'0.5"</b>	1231 mm	<b>4'0.5"</b>	1231 mm	<b>4'1"</b>
Maximum Hydraulic Tilt	951 mm	<b>3'1.4"</b>	1028 mm	<b>3'4.5"</b>		—

<b>MODEL</b>	<b>D9T WHA</b>				<b>D10T WHA</b>	
	<b>9SU</b>		<b>9U</b>		<b>10U</b>	
Type						
Blade Capacities*	28.8 m <sup>3</sup>	<b>37.6 yd<sup>3</sup></b>	33.5 m <sup>3</sup>	<b>43.8 yd<sup>3</sup></b>	48.9 m <sup>3</sup>	<b>63.9 yd<sup>3</sup></b>
Dozer Weight**	6964 kg	<b>15,353 lb</b>	8059 kg	<b>17,751 lb</b>		—
Tractor and Dozer Dimensions:						
Length Blade Straight	6.84 m	<b>22'5"</b>	7.18 m	<b>23'7"</b>	8.01 m	<b>26'3"</b>
Blade Dimensions:						
Width including std. end bits	4.31 m	<b>14'2"</b>	4.65 m	<b>15'3"</b>	5.26 m	<b>17'3"</b>
Height	2845 mm	<b>9'4"</b>	2845 mm	<b>9'4"</b>	3174 mm	<b>10'5"</b>
Maximum Dig Depth	606 mm	<b>1'11.9"</b>	606 mm	<b>1'11.9"</b>	679 mm	<b>2'2.5"</b>
Ground Clearance at full raise	1422 mm	<b>4'8"</b>	1422 mm	<b>4'8"</b>	1497 mm	<b>4'10.9"</b>
Maximum Hydraulic Tilt	940 mm	<b>3'1"</b>	1014 mm	<b>3'3.9"</b>	1074 mm	<b>3'6.3"</b>

\*Blade capacities, weights and heights include 762 mm (2'6") trash rack on D8T blades, 914 mm (3'0") trash rack on D9T blades, and 1067 mm (3'6") trash rack on D10T blades.

\*\*Total bulldozer arrangement includes blade with trash rack, pusharms, braces, cylinders, lines, trunnions and lift cylinder mountings.

**Features:**

- **Unmatched versatility** — excavates, loads, carries, covers, dozes, spreads, compacts, shreds, sorts, grapples — a true all purpose machine. Performs well as a one-machine fleet, a support machine or an all-around backup unit.
- **Demolition applications** — The Waste Handling Arrangement (963D and 973D Waste Demolition Specials) can also be used in demolition or demolition transfer stations when properly equipped with the extra guarding required for this severe environment.
- **Special guard** protects the final drive seals, pivot shafts and idlers from debris that can wrap around and damage these components.
- **Cat Turbine Precleaner** with prescreener to prevent airborne debris from clogging engine air intake.
- **Additional heavy duty guarding** helps protect sheet metal and machine components from damage in waste handling applications.
- **Improved serviceability** — swing open doors, guards and air coolers give quick access for cleaning debris and servicing.
- **Hinged, heavy duty radiator guard** with quick release “T” handles allows for easy access to clean the radiator.
- **Debris Barrier Package** protects machine from material entering engine and other compartments.
- **Lamp guard group** protects front and rear lamps with bolt on grids.
- **Optional rear striker bars** keep trash from climbing the track and damaging fenders.
- **Optional final drive abrasion guards** are available in two-piece or four-piece sections to protect the final drive case from premature wear from abrasion or gouging.
- **Optional single grouser, trapezoidal-shaped center hole track shoes** provide maximum traction. The center holes allow sprocket to punch out dirt and debris, best choice for landfill applications.
- **Hydraulic reversing fan (953D and 963D) or Flexxaire engine cooling fan** (optional on 973D) manually or automatically changes direction to purge accumulated debris from the radiator.
- **Cab and Operator Comfort** — Standard air suspension seat, air conditioning, adjustable steering pedals, storage area, and excellent visibility enable the operator to be more comfortable in this application for better profitability.



MODEL	953D WHA		963D WHA		973D WHA	
Flywheel Power	110 kW	<b>148 hp</b>	141 kW	<b>189 hp</b>	196 kW	<b>263 hp</b>
Operating Weight*	15 595 kg	<b>34,381 lb</b>	21 000 kg	<b>46,305 lb</b>	29 555 kg	<b>65,158 lb</b>
Engine Model	<b>C6.6 ACERT</b>		<b>C6.6 ACERT</b>		<b>C9 ACERT</b>	
Rated Engine RPM	<b>2000</b>		<b>2000</b>		<b>1900</b>	
Bore	105 mm	<b>4"</b>	105 mm	<b>4.13"</b>	112 mm	<b>4.41"</b>
Stroke	127 mm	<b>5"</b>	127 mm	<b>5"</b>	149 mm	<b>5.87"</b>
No. Cylinders	<b>6</b>		<b>6</b>		<b>6</b>	
Displacement	6.6 L	<b>402.7 in<sup>3</sup></b>	6.6 L	<b>402.7 in<sup>3</sup></b>	8.8 L	<b>537 in<sup>3</sup></b>
Speeds, Forward/Reverse:						
1st	0-10 km/h	<b>0-6.2 mph</b>	0-10 km/h	<b>0-6.2 mph</b>	0-11 km/h	<b>0-6.8 mph</b>
2nd	<b>Infinitely</b>		<b>Infinitely</b>		<b>Infinitely</b>	
3rd	<b>Variable</b>		<b>Variable</b>		<b>Variable</b>	
Hydraulic Cycle Time, Bucket Empty, in Seconds:						
Raise	<b>6.1</b>		<b>5.9</b>		<b>6.5</b>	
Dump	<b>3.1</b>		<b>3.7</b>		<b>1.4</b>	
Lower (Empty, Float Down)	<b>3.2</b>		<b>2.2</b>		<b>2.7</b>	
Total	<b>—</b>		<b>—</b>		<b>10.6</b>	
Track Rollers (Each Side)	<b>6</b>		<b>6</b>		<b>7</b>	
Width of Standard Track Shoes	480 mm	<b>19"</b>	550 mm	<b>21.6"</b>	550 mm	<b>21.6"</b>
Length of Track on Ground	2323 mm	<b>91.4"</b>	2543 mm	<b>100.1"</b>	2930 mm	<b>115"</b>
Ground Contact Area (with Standard Shoes)	2.3 m <sup>2</sup>	<b>3565 in<sup>2</sup></b>	2.8 m <sup>2</sup>	<b>4340 in<sup>2</sup></b>	3.22 m <sup>2</sup>	<b>4991 in<sup>2</sup></b>
Ground Pressure	65.5 kPa	<b>9.5 psi</b>	71.5 kPa	<b>10.3 psi</b>	90.0 kPa	<b>13.0 psi</b>
Ground Clearance	436 mm	<b>17.2"</b>	483 mm	<b>19"</b>	482 mm	<b>18.9"</b>
Track Gauge	1800 mm	<b>71"</b>	1850 mm	<b>72.8"</b>	2160 mm	<b>85"</b>
Width without Bucket	2280 mm	<b>89.7"</b>	2400 mm	<b>94.5"</b>	2710 mm	<b>106.7"</b>
Fuel Tank Refill Capacity	285 L	<b>75.3 U.S. gal</b>	336.5 L	<b>88.8 U.S. gal</b>	621 L	<b>164 U.S. gal</b>
Hydraulic System Refill Capacity	124 L	<b>32.8 U.S. gal</b>	166 L	<b>43.8 U.S. gal</b>	189 L	<b>50 U.S. gal</b>

\*Includes GP landfill bucket with bolt-on adapters, long tips and segments.

See Wheel Loader section of this book for summary of S.A.E. Guidelines for Loader Specifications, to which Caterpillar adheres.

**MULTI-PURPOSE  
LANDFILL BUCKETS**

Machine Model	953D		963D		973D	
Capacity, rated (Refuse)	2.1 m <sup>3</sup>	<b>2.75 yd<sup>3</sup></b>	2.7 m <sup>3</sup>	<b>3.5 yd<sup>3</sup></b>	4.6 m <sup>3</sup>	<b>6 yd<sup>3</sup></b>
Capacity, rated (Earth)	1.5 m <sup>3</sup>	<b>2 yd<sup>3</sup></b>	1.8 m <sup>3</sup>	<b>2.4 yd<sup>3</sup></b>	2.7 m <sup>3</sup>	<b>3.53 yd<sup>3</sup></b>
Width	2536 mm	<b>99.84"</b>	2573 mm	<b>101.30"</b>	2946 mm	<b>115.9"</b>
Height	1677 mm	<b>66.02"</b>	1750 mm	<b>68.90"</b>	1944 mm	<b>76.58"</b>
Depth	1433 mm	<b>56.41"</b>	1537 mm	<b>60.51"</b>	1607 mm	<b>63.3"</b>
Teeth — Optional		<b>8</b>		<b>8</b>		<b>8</b>
Clearance @ 45° dump	2738 mm	<b>9'0"</b>	2870 mm	<b>9'5"</b>	3060 mm	<b>120.5"</b>
Reach @ 45° dump	961 mm	<b>3'2"</b>	1013 mm	<b>3'4"</b>	1261 mm	<b>49.6"</b>
Digging Depth	147 mm	<b>5.7"</b>	161 mm	<b>6.3"</b>	—	
Weight (approx.)	1668 kg	<b>3678 lb</b>	2206 kg	<b>4864 lb</b>	3575 kg	<b>7882 lb</b>

**GENERAL PURPOSE  
LANDFILL BUCKETS**

Machine Model	953D		963D		973D	
Capacity, rated (Refuse)	2.3 m <sup>3</sup>	<b>3.0 yd<sup>3</sup></b>	3.1 m <sup>3</sup>	<b>4.1 yd<sup>3</sup></b>	4.9 m <sup>3</sup>	<b>6.41 yd<sup>3</sup></b>
Capacity, rated (Earth)	1.75 m <sup>3</sup>	<b>2.29 yd<sup>3</sup></b>	2.3 m <sup>3</sup>	<b>3.0 yd<sup>3</sup></b>	3.2 m <sup>3</sup>	<b>4.2 yd<sup>3</sup></b>
Width	2458 mm	<b>96.77"</b>	2612 mm	<b>102.83"</b>	2910 mm	<b>114.6"</b>
Height	1607 mm	<b>63.2"</b>	1778 mm	<b>70"</b>	1936 mm	<b>76.2"</b>
Depth	1450 mm	<b>57.1"</b>	1480 mm	<b>58.3"</b>	1491 mm	<b>58.7"</b>
Teeth — Optional		<b>8</b>		<b>8</b>		<b>8</b>
Clearance @ 45° dump	2855 mm	<b>9'0"</b>	3155 mm	<b>10'4"</b>	3261 mm	<b>128.4"</b>
Reach @ 45° dump	999 mm	<b>3'3"</b>	1147 mm	<b>3'9"</b>	1191 mm	<b>46.9"</b>
Digging Depth	85 mm	<b>5.7"</b>	161 mm	<b>6.3"</b>	—	
Weight (approx.)	1266 kg	<b>2792 lb</b>	1888 kg	<b>4163 lb</b>	2320 kg	<b>5115 lb</b>

**NOTE:** 973D GP and MP landfill buckets are equipped with bolt-on segments and teeth general duty.



### Features:

- **Caterpillar designed and manufactured power train ...** for optimum match, performance and efficiency. Responsive Cat diesel engine. Single-lever planetary power shift. All-wheel drive.
- **Center-point articulation ...** excellent maneuverability. Front and rear drums track, so material is chopped and compacted twice each pass.
- **Protective guarding ...** helps keep trash from damaging machine components.
- **Cat landfill blades** spread refuse and cover material ... built strong to handle the wide range of refuse encountered in landfills.
- **Operator comfort and convenience ...** sound suppressed cab with pressurized and filtered air circulation system. Adjustable suspension seat. Electronic Monitoring System and gauge package is standard. Optional air conditioner available.
- **Striker bars ...** standard on 816F2, 826H and 836H, prevents refuse from being carried over the rear wheels.
- **Smooth wheel option ...** If our tip selection does not meet your needs, consider our Cat smooth steel wheel. We test and build a Cat system. Engineers who work together with our power train, structures and manufacturing engineers design and manufacture our wheels in the same facility in which the machines are designed and built. This ensures the entire system is complemented by each component. If you alter components, you could compromise a system that was designed and tested for peak performance. If a wheel is produced that does not meet our design specifications and does not balance the load over our final drives, it could reduce the life of the bearing substantially and wear out other components creating unnecessary downtime. This also allows our standard axle guard system to work with the components for which it was designed.



MODEL	816F2		826H		836H	
Flywheel Power	189 kW	253 hp	264 kW	354 hp	372 kW	499 hp
Operating Weight*	23 744 kg	52,364 lb	36 967 kg	81,498 lb	53 682 kg	118,348 lb
Engine Model	C9 ACERT		C15 ACERT		C18 ACERT	
Rated Engine RPM	2100		1800		1800	
No. Cylinders	6		6		6	
Displacement	8.8 L	537 in <sup>3</sup>	15.2 L	928 in <sup>3</sup>	18.1 L	1105 in <sup>3</sup>
Speeds:						
Forward	2		2		2	
Reverse	2		2		2	
Turning Radius with Straight Blade						
Inside Blade Corner	3.5 m	11'6"	3.2 m	10'6"	4.3 m	14'11"
Outside Blade Corner	6.5 m	21'2"	7.3 m	24'6"	9.0 m	29'6"
Fuel Tank Refill Capacity	464 L	122.6 U.S. gal	640 L	169.1 U.S. gal	795 L	210 U.S. gal
WHEELS:	PLUS TIP		PLUS TIP		PLUS TIP	
Each Drum Width	1.02 m	3'4"	1.2 m	3'11"	1.4 m	4'7"
Diameters, over Tips	1.7 m	5'10"	1.9 m	6'6"	2.0 m	6'9"
Drum only	1.3 m	4'3"	1.53 m	5'0"	1.62 m	5'8"
Tips per Wheel	20		25		35	
Tip Height	158 mm	6.5"	158 mm	6.5"	158 mm	6.5"
Chopper Blades per Wheel	20		24		28	
Blade Height	152 mm	6"	158 mm	6"	158 mm	6"
Width of Two Pass Coverage	4.5 m	14'9"	4.78 m	15'8"	5.67 m	18'7"
GENERAL DIMENSIONS:						
Height (Overall)	3.8 m	12'8"	4.2 m	13'7"	4.5 m	14'9"
Height (Top of Cab)	3.4 m	11'3"	3.8 m	12'8"	4.1 m	13'6"
Wheel Base	3.35 m	11'0"	3.7 m	12'2"	4.55 m	14'11"
Overall Length with Dozer	7.85 m	25'7"	8.27 m	27'2"	10.18 m	33'5"
Width over Drums	3.33 m	10'11"	3.8 m	12'8"	4.18 m	14'1"
Ground Clearance	456 mm	1'5"	489 mm	1'6"	697 mm	2'3"
LANDFILL BULLDOZER:						
Width	3.65 m	12'0"	4.5 m	14'9"	5.19 m	17'0"
Height**	1.91 m	6'3"	1.91 m	6'3"	2.22 m	7'3"

\*Operating Weight includes coolant, full hydraulics, full fuel tank, all heaviest options and 82 kg (180 lb) operator.

\*\*Height (stripped top) — without ROPS cab, exhaust, seat back or other easily removed encumbrances.

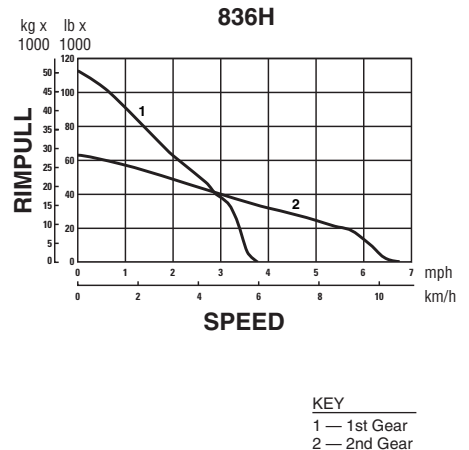
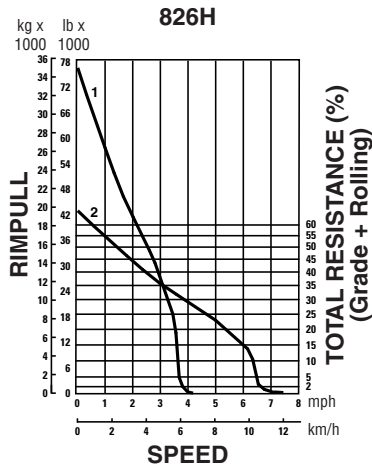
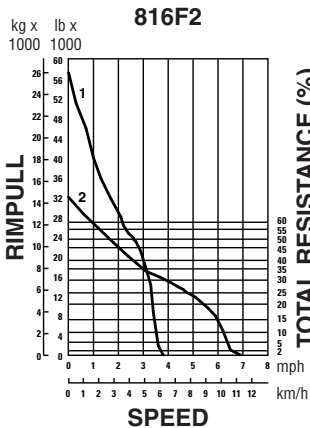

<b>MODEL</b>	<b>816F2</b>		<b>826H</b>		<b>836H</b>	
Type	<b>Landfill Spreading</b>		<b>Landfill Spreading</b>		<b>147-4425 Straight</b>	
Capacity**						
Earth	2.9 m <sup>3</sup>	<b>3.79 yd<sup>3</sup></b>	3.68 m <sup>3</sup>	<b>4.81 yd<sup>3</sup></b>	5 m <sup>3</sup>	<b>6.66 yd<sup>3</sup></b>
Refuse	11 m <sup>3</sup>	<b>14.39 yd<sup>3</sup></b>	13 m <sup>3</sup>	<b>17 yd<sup>3</sup></b>	19.8 m <sup>3</sup>	<b>25.9 yd<sup>3</sup></b>
Weight, Dozer*	2107 kg	<b>4645 lb</b>	2739 kg	<b>6038 lb</b>	3400 kg	<b>7650 lb</b>
General Dimensions: (Tractor and Dozer)						
Length	7.85 m	<b>25'9"</b>	8.33 m	<b>27'4"</b>	10.18 m	<b>33'4"</b>
Width	3.65 m	<b>12'0"</b>	4.5 m	<b>14'9"</b>	5.19 m	<b>17'0"</b>
Blade Dimensions:						
Width, End Bits	3.65 m	<b>12'0"</b>	4.5 m	<b>14'9"</b>	5.19 m	<b>17'0"</b>
Height, Trash Rack	1914 mm	<b>6'3"</b>	1898 mm	<b>6'2"</b>	2222 mm	<b>7'3"</b>

\*Total Bulldozer Arrangement.

\*\*Blade capacities determined by SAE recommended practice J1265.

<b>U-BLADE</b>	<b>816F2</b>		<b>826H</b>		<b>836H</b>	
<b>Model:</b>	<b>7Q-8239</b>		<b>263-6869</b>		<b>260-2015</b>	
<b>Blade:</b>						
Capacity (Refuse)	9.74 m <sup>3</sup>	<b>12.74 yd<sup>3</sup></b>	16.7 m <sup>3</sup>	<b>21.8 yd<sup>3</sup></b>	9.74 m <sup>3</sup>	<b>13 yd<sup>3</sup></b>
Length (Cutting Width)	3.73 m	<b>12'3"</b>	4.39 m	<b>14'5"</b>	3.73 m	<b>12'3"</b>
Weight, Installed (without Hydraulics)	—	—	2935 kg	<b>6471 lb</b>	3839 kg	<b>8465 lb</b>

<b>SEMI-U BLADE</b>	<b>816F2</b>		<b>826H</b>		<b>836H</b>	
<b>Model:</b>	<b>213-4473</b>		<b>263-6870</b>		<b>260-2016</b>	
<b>Blade:</b>						
Capacity (Refuse)	8.95 m <sup>3</sup>	<b>11.71 yd<sup>3</sup></b>	14.5 m <sup>3</sup>	<b>18.9 yd<sup>3</sup></b>	22.4 m <sup>3</sup>	<b>29.3 yd<sup>3</sup></b>
Length (Cutting Width)	3.71 m	<b>12'2"</b>	4.49 m	<b>14'9"</b>	5.31 m	<b>17'5"</b>
Weight, Installed (without Hydraulics)	—	—	3004 kg	<b>6623 lb</b>	3744 kg	<b>8256 lb</b>

**Features:**

Cat Waste Handling Wheel Loaders are equipped with the features and protection required in a demanding waste handling environment. These Caterpillar designed and built machines feature the following advantages:

- **Exceptional productivity** with fast cycle times for maximum production day-in day-out whether dozing, loading, stacking, or load and carry.
- **Protected work environment** enhances operator comfort, convenience and productivity.
- **Modified front frames** — (Standard on the 980H WHA) provide large cutouts that allows debris to fall out rather than packing and also provide easy access if cleaning is necessary.
- **Standard front drive guard and axle seal guards** (except 980H) protect from wire, string, strapping and other debris from wrapping and causing damage.
- **Front light guards** protect the lights from debris falling over the bucket spill plate.
- **Hinged crankcase and power train guards** help protect the engine and power train. The hinged design provides easy access for cleaning. (Powered guards available on some models.)
- **Standard waste application cooling system.** The improved, trash-resistant, multi-row module (IMRM) radiator, hood and engine enclosures work as a system to keep the radiator and engine compartment free of debris.
- **Trash resistant IMRM radiator** has six fins per inch (25.4 mm) and in-line tubes that resist plugging by allowing debris to pass through the core.
- **Hinged radiator prescreener** (966H and 972H) eliminates debris larger than what the radiator core will pass.
- **Hinged grill** (966H and 972H) allows access to hydraulic oil cooler and air conditioning condenser, which swing out for easy cleaning.

**Recommended Waste Handling Options**

- **Powered crankcase and power train guards** raise and lower at the flip of a switch allowing fast, easy and frequent cleanings.
- **High lift arrangement** increases bucket hinge pin height offering increased stacking and stockpiling capability. A critical feature when incoming volumes exceed conveyor capacity or floor space.
- **Traction control system (TCS)** option for 938H/IT38H provides maximum traction in slippery conditions. TCS electronically senses and limits wheel slip at each wheel independently.
- **Limited-slip differential** limits tire slip on both front and rear axles. Increases traction and reduces tire wear and scuffing in wet or dry conditions. Provides an alternative to the No SPIN differential which is not recommended due to increased tire wear, turning interference and poor tracking on dry surfaces.
- **Tire options:**
  - L-5 bias hard rock lug
  - L-5 slick
  - RL-5K Goodyear radials
  - XMINE Michelin radials (varies by model)
  - Foam-filled
- **Hitch guards** help protect components in hitch area from damage.
- **Reversing radiator fan** is hydraulically driven and can be reversed by a switch in the operator station or automatically by timer. Reduces need for cooling system cleaning and improves cooling capability.
- **Other guarding and options** are available. Contact your Cat dealer for information.

**Work Tools**

- **Refuse bucket** has excellent dozing and stockpiling capability. Large spill plate helps protect the machine from debris falling over the top of the bucket. Available in pin-on or quick coupler configurations.
- **Pallet forks** are ideal for handling refuse destined for further recycling or stacking refuse in landfills for covering.

- **Multi-purpose bucket** has the capability to clamp and sort large objects, doze cover material or other light dozing chores.
- **Quick coupler** increases versatility by allowing a single machine to utilize a wide variety of work tools in a host of applications.



<b>MODEL</b>	<b>924Hz WHA</b>		<b>924H WHA</b>		<b>928Hz WHA</b>		<b>930H WHA</b>	
Flywheel Power	96 kW	<b>129 hp</b>	96 kW	<b>129 hp</b>	111 kW	<b>149 hp</b>	111 kW	<b>149 hp</b>
Peak Power	102 kW	<b>137 hp</b>	102 kW	<b>137 hp</b>	119 kW	<b>160 hp</b>	119 kW	<b>160 hp</b>
Engine Model	<b>C6.6</b>		<b>C6.6</b>		<b>C6.6</b>		<b>C6.6</b>	
Rated Engine RPM	<b>2300</b>		<b>2300</b>		<b>2300</b>		<b>2300</b>	
Bore	105 mm	<b>4.13"</b>	105 mm	<b>4.13"</b>	105 mm	<b>4.13"</b>	105 mm	<b>4.13"</b>
Stroke	127 mm	<b>5"</b>	127 mm	<b>5"</b>	127 mm	<b>5"</b>	127 mm	<b>5"</b>
No. Cylinders	<b>6</b>		<b>6</b>		<b>6</b>		<b>6</b>	
Displacement	6.6 L	<b>403 in<sup>3</sup></b>	6.6 L	<b>403 in<sup>3</sup></b>	6.6 L	<b>403 in<sup>3</sup></b>	6.6 L	<b>403 in<sup>3</sup></b>
Speeds Forward	<b>km/h</b>	<b>mph</b>	<b>km/h</b>	<b>mph</b>	<b>km/h</b>	<b>mph</b>	<b>km/h</b>	<b>mph</b>
1st	6.6	<b>4.1</b>	6.6	<b>4.1</b>	7.9	<b>4.9</b>	6.9	<b>4.3</b>
2nd	12.0	<b>7.5</b>	12.0	<b>7.5</b>	12.6	<b>7.8</b>	12.9	<b>8.0</b>
3rd	21.3	<b>13.2</b>	21.3	<b>13.2</b>	25.8	<b>16.0</b>	22.9	<b>14.2</b>
4th	38.0	<b>23.6</b>	38.0	<b>23.6</b>	37.7	<b>23.4</b>	39.7	<b>24.7</b>
Speeds Reverse								
1st	6.6	<b>4.1</b>	6.6	<b>4.1</b>	7.9	<b>4.9</b>	6.9	<b>4.3</b>
2nd	12.0	<b>7.5</b>	12.0	<b>7.5</b>	12.6	<b>7.8</b>	12.9	<b>8.0</b>
3rd	21.3	<b>13.2</b>	21.3	<b>13.2</b>	25.8	<b>16.0</b>	22.9	<b>14.2</b>
Hydraulic Cycle Time*								
Rated Load in Bucket:	<b>Seconds</b>		<b>Seconds</b>		<b>Seconds</b>		<b>Seconds</b>	
Raise	<b>5.2</b>		<b>5.2</b>		<b>6.0</b>		<b>5.0</b>	
Dump	<b>1.1</b>		<b>1.6</b>		<b>1.2</b>		<b>1.7</b>	
Lower (empty, float down)	<b>3.0</b>		<b>2.7</b>		<b>3.0</b>		<b>2.9</b>	
Total	<b>9.3</b>		<b>9.5</b>		<b>10.2</b>		<b>9.6</b>	
Tread Width**	1.83 m	<b>6'0"</b>	1.83 m	<b>6'0"</b>	1.95 m	<b>6'5"</b>	1.96 m	<b>6'5"</b>
Width Over Tires**	2.44 m	<b>8'0"</b>	2.44 m	<b>8'0"</b>	2.57 m	<b>8'5"</b>	2.57 m	<b>8'5"</b>
Ground Clearance**	436 mm	<b>1'5"</b>	436 mm	<b>1'5"</b>	408 mm	<b>1'4"</b>	411 mm	<b>1'4"</b>
Fuel Tank Capacity	225 L	<b>59.4 U.S. gal</b>	225 L	<b>59.4 U.S. gal</b>	225 L	<b>59.4 U.S. gal</b>	225 L	<b>59.4 U.S. gal</b>
Hydraulic Tank Capacity	70 L	<b>18.5 U.S. gal</b>	70 L	<b>18.5 U.S. gal</b>	70 L	<b>18.5 U.S. gal</b>	70 L	<b>18.5 U.S. gal</b>
Hinge Pin Height:								
Full Lift Std.	3.76 m	<b>12'4"</b>	3.88 m	<b>12'9"</b>	3.87 m	<b>12'8"</b>	4.049 m	<b>13'3"</b>
High Lift	—		4.32 m	<b>14'2"</b>	—		4.549 m	<b>14'11"</b>
Operating weight up to:	12 613 kg	<b>27,749 lb</b>	13 348 kg	<b>29,366 lb</b>	14 092 kg	<b>31,002 lb</b>	14 913 kg	<b>32,809 lb</b>

\*With standard lift arms.

\*\*With standard tires.



**938H WHA  
IT38H WHA**

**950H WHA**

**962H WHA  
IT62H WHA**

<b>MODEL</b>	<b>938H WHA IT38H WHA</b>		<b>950H WHA</b>		<b>962H WHA IT62H WHA</b>	
Net Power	134 kW	<b>180 hp</b>	146 kW	<b>196 hp</b>	158 kW	<b>211 hp</b>
Gross Power	147 kW	<b>197 hp</b>	161 kW	<b>216 hp</b>	172 kW	<b>230 hp</b>
Engine Model	<b>C6.6</b>		<b>C7 ATAAC</b>		<b>C7 ATAAC</b>	
Rated Engine RPM	<b>2100</b>		<b>1800</b>		<b>1800</b>	
Bore	105 mm	<b>4.13"</b>	110 mm	<b>4.3"</b>	110 mm	<b>4.3"</b>
Stroke	127 mm	<b>5"</b>	127 mm	<b>5"</b>	127 mm	<b>5"</b>
No. Cylinders	<b>6</b>		<b>6</b>		<b>6</b>	
Displacement	6.6 L	<b>403 in<sup>3</sup></b>	7.2 L	<b>439 in<sup>3</sup></b>	7.2 L	<b>439 in<sup>3</sup></b>
Speeds Forward	<b>km/h</b>	<b>mph</b>	<b>km/h</b>	<b>mph</b>	<b>km/h</b>	<b>mph</b>
1st	7.9	<b>4.9</b>	6.9	<b>4.3</b>	7.0	<b>4.4</b>
2nd	14.2	<b>8.8</b>	12.7	<b>7.9</b>	13.0	<b>8.1</b>
3rd	25.0	<b>15.5</b>	22.3	<b>13.9</b>	22.6	<b>14.0</b>
4th	41.1	<b>25.5</b>	37.0	<b>23.0</b>	38.0	<b>23.6</b>
Speeds Reverse						
1st	7.9	<b>4.9</b>	7.6	<b>4.7</b>	7.6	<b>4.7</b>
2nd	14.2	<b>8.8</b>	13.9	<b>8.6</b>	13.9	<b>8.6</b>
3rd	25.0	<b>15.5</b>	24.5	<b>15.2</b>	24.5	<b>15.2</b>
4th	—		40.5	<b>24.9</b>	40.0	<b>24.9</b>
Hydraulic Cycle Time*	<b>Seconds</b>		<b>Seconds</b>		<b>Seconds</b>	
Rated Load in Bucket:	<b>938H</b>	<b>IT38H</b>				
Raise	<b>5.4</b>	<b>5.0</b>	<b>6.2</b>		<b>6.2</b>	
Dump	<b>1.4</b>	<b>2.0</b>	<b>1.3</b>		<b>1.3</b>	
Lower (empty, float down)	<b>2.7</b>	<b>2.7</b>	<b>2.5</b>		<b>2.5</b>	
Total	<b>9.5</b>	<b>9.7</b>	<b>10.0</b>		<b>10.0</b>	
Tread Width**	2.02 m	<b>6'8"</b>	2.14 m	<b>7'0"</b>	2.14 m	<b>7'0"</b>
Width Over Tires**	2.65 m	<b>8'8"</b>	2.79 m	<b>9'2"</b>	2.79 m	<b>9'2"</b>
Ground Clearance**	397 mm	<b>16"</b>	412 mm	<b>16"</b>	412 mm	<b>16"</b>
Fuel Tank Capacity	247 L	<b>65.3 U.S. gal</b>	314 L	<b>83 U.S. gal</b>	314 L	<b>83 U.S. gal</b>
Hydraulic Tank Capacity	89 L	<b>23.5 U.S. gal</b>	110 L	<b>29 U.S. gal</b>	110 L	<b>29 U.S. gal</b>
Hinge Pin Height:						
Full Lift Std.	3.85 m	<b>12'7"</b>	3.99 m	<b>13'1"</b>	3.99 m	<b>13'1"</b>
High Lift w/L-5 tires	4.27 m	<b>13'11"</b>	4.54 m	<b>14'10"</b>	—	
Operating weight up to:	18 143 kg	<b>40,000 lb</b>	19 213 kg	<b>42,365 lb</b>	20 269 kg	<b>44,693 lb</b>

\*With standard lift arms.

\*\*With standard tires.



<b>MODEL</b>	<b>966H WHA</b>		<b>972H WHA</b>		<b>980H WHA</b>	
Net Power	195 kW	<b>262 hp</b>	214 kW	<b>287 hp</b>	237 kW	<b>318 hp</b>
Gross Power	211 kW	<b>283 hp</b>	229 kW	<b>307 hp</b>	261 kW	<b>351 hp</b>
Engine Model	<b>C11 ATAAC</b>		<b>C13 ATAAC</b>		<b>C15</b>	
Rated Engine RPM	<b>1800</b>		<b>1800</b>		<b>1800</b>	
Bore	130 mm	<b>5.1"</b>	130 mm	<b>5.1"</b>	137 mm	<b>5.4"</b>
Stroke	140 mm	<b>5.5"</b>	157 mm	<b>6.2"</b>	171 mm	<b>6.75"</b>
No. Cylinders	<b>6</b>		<b>6</b>		<b>6</b>	
Displacement	11.1 L	<b>677 in<sup>3</sup></b>	12.5 L	<b>763 in<sup>3</sup></b>	15.2 L	<b>928 in<sup>3</sup></b>
Speeds Forward	<b>km/h</b>	<b>mph</b>	<b>km/h</b>	<b>mph</b>	<b>km/h</b>	<b>mph</b>
1st	6.7	<b>4.2</b>	7.2	<b>4.5</b>	6.6	<b>4.1</b>
2nd	12.6	<b>7.8</b>	12.6	<b>7.8</b>	11.8	<b>7.3</b>
3rd	22.1	<b>13.7</b>	21.4	<b>13.3</b>	20.7	<b>12.9</b>
4th	37.4	<b>23.2</b>	36.9	<b>22.9</b>	36.3	<b>22.6</b>
Speeds Reverse						
1st	7.4	<b>4.6</b>	8.2	<b>5.1</b>	7.6	<b>4.7</b>
2nd	13.7	<b>8.6</b>	14.2	<b>8.8</b>	13.5	<b>8.4</b>
3rd	23.4	<b>15.1</b>	24.3	<b>15.1</b>	23.7	<b>14.7</b>
4th	37.4	<b>23.2</b>	38.8	<b>24.0</b>	41.5	<b>25.8</b>
Hydraulic Cycle Time*						
Rated Load in Bucket:	<b>Seconds</b>		<b>Seconds</b>		<b>Seconds</b>	
Raise	<b>5.9</b>		<b>5.9</b>		<b>6.0</b>	
Dump	<b>1.6</b>		<b>2.1</b>		<b>2.0</b>	
Lower (empty, float down)	<b>2.4</b>		<b>2.4</b>		<b>3.4</b>	
Total	<b>9.9</b>		<b>10.4</b>		<b>11.4</b>	
Tread Width**	2.23 m	<b>7'4"</b>	2.23 m	<b>7'4"</b>	2.44 m	<b>8'0"</b>
Width Over Tires**	3.00 m	<b>9'10"</b>	3.00 m	<b>9'10"</b>	3.23 m	<b>10'7"</b>
Ground Clearance**	496 mm	<b>20"</b>	496 mm	<b>20"</b>	442 mm	<b>17.4"</b>
Fuel Tank Capacity	380 L	<b>100 U.S. gal</b>	380 L	<b>100 U.S. gal</b>	479 L	<b>127 U.S. gal</b>
Hydraulic Tank Capacity	110 L	<b>29 U.S. gal</b>	110 L	<b>29 U.S. gal</b>	125 L	<b>33 U.S. gal</b>
Hinge Pin Height:						
Full Lift Std.	4.23 m	<b>13'10"</b>	4.87 m	<b>14'8"</b>	4.51 m	<b>14'9"</b>
High Lift w/L-5 tires	4.79 m	<b>15'8"</b>	4.81 m	<b>15'9"</b>	4.75 m	<b>15'7"</b>
Operating weight up to:	24 237 kg	<b>53,443 lb</b>	26 051 kg	<b>57,442 lb</b>	31 599 kg	<b>69,676 lb</b>

\*With standard lift arms.

\*\*With standard tires.

# TECHNOLOGY PRODUCTS

## CONTENTS

Introduction	26-1
Product vs. Application chart	26-3
Product Link	26-6
AccuGrade™ Grade Control System (GCS)	26-8
AccuGrade™ Paving Control System (PCS)	26-11
AccuGrade™ Compaction Control System (CCS)	26-12
Computer Aided Earthmoving System (CAES)	26-13
AQUILA™ Drill System	26-15
AQUILA™ Dragline System	26-16
MineStar™ FleetCommander	26-17
MineStar™ Health	26-18
VIMS™ System	26-19
Cat® Integrated Object Detection System™	26-20
Cat® Integrated Remote Control	26-21
MINEGEM™ Underground Mining Automation System	26-22
Work Area Vision System (WAVS)	26-23

## INTRODUCTION

In Cat machines you'll discover a unique combination of iron and electronics. Powerful, productive — equipped with the latest in proven information technology. A full line of systems that will work harder, last longer, and help you move more material at a lower cost.

At Caterpillar, we've applied technologies selectively — incorporating only those that deliver intelligent solutions. So if it doesn't improve performance, increase productivity, extend component life, help the operator, reduce service time, lower operating costs, enhance resale value, address an environmental challenge, or make your time more efficient, you won't find it on our machines. Utilizing these technologies provides the most advanced systems available to keep your site running at peak efficiency and productivity, at the lowest possible owning and operating costs.

**Grade, paving and compaction control systems** are centered around robust position awareness technologies and rugged on-board systems, revolutionizing the movement of material. Guidance products provide real-time job progress with centimeter-level accuracy to the operator, eliminating guesswork that leads to rework or constant surveying, slowing progress and driving up costs. Control products take this technology a step further by integrating position awareness to automatically adjust the work tool. This results in accurately meeting the design plan while reducing the number of passes needed.

- AccuGrade™ Grade Control System (GCS)
- AccuGrade Paving Control System (PCS)
- AccuGrade Compaction Control System (CCS)
- Computer Aided Earthmoving System (CAES) for Landfill



**Sustainability:**

- **Reduce electronic component waste** — For all displays and GPS receivers utilized in Caterpillar's mining technology products, Caterpillar offers repair services and remanufactured components. This reduces the number of electronic components in landfills and ensures any unrepairable components are disposed of properly.
- **Productivity gains** — Each mining technology solution improves mine productivity ranging from 10–25%. By increasing productivity, mines can achieve higher productivity without increasing the number of machines which translates to more tons with fewer overall emissions.
- **Increased utilization of natural resources while lowering processing costs** — Cat mining technology products help mines ensure ore and waste materials are properly identified and routed. This means that less ore is wasted by misdirected loads. Cat products also minimize processing costs and chemicals by reducing the amount of waste material sent to the processing plant.

**Mining Technology Products** continue to have a positive impact on mining operations around the world. Caterpillar offers a complete suite of technology products purpose built for the harsh mining environment. Our products combine the latest GNSS positioning technology with sophisticated electronic control modules and software to help miners increase productivity, monitor fleet health and lower operating costs.

- MineStar™ FleetCommander
- MineStar™ Health
- AQUILA™ Drill System
- AQUILA™ Dragline System
- CAESultra for Mining
- Cat® Integrated Object Detection System™
- Cat® Integrated Remote Control
- MINEGEM™ Underground Mining Automation System
- Work Area Vision System (WAVS)
- VIMS™ System

**Fleet Management** products and services provide data and information about multiple aspects of equipment, such as machine location, hours and health, to help customers more effectively manage down-time and plan maintenance. Offerings in this category are:

- [Product Link](#)

For more information on these and other Cat technology products, visit [www.cat.com/pl](http://www.cat.com/pl).

PRODUCT	APPLICATIONS	MACHINES
Product Link	Product Link enables remote monitoring of your equipment to help keep your jobs on schedule, maintain machine health and reduce the costs of owning and operating your fleet. The system provides information via satellite or cellular connection to simplify fleet management, track equipment, maximize uptime, monitor machine usage and link your entire fleet.	Product Link comes standard on many Cat machines, and is available for retrofit on Cat and other brands of equipment.
AccuGrade™ GCS 600	Automatic cross slope system to control one end of the Motor Grader blade to correlate manually controlled slope of the other end. For finish grading, automatic elevation control (Sonic or Laser) can be added to reference string line/curb or laser transmitter. Additionally, this system can be upgraded to AccuGrade GCS 900.	Motor Graders
	For finish grading, automatic laser elevation control can be added to reference laser transmitter. Additionally, this system can be upgraded to AccuGrade GCS 900.	Track-Type Tractors
	Indicate only site and laser reference systems. Provides depth and slope guidance for trenches and excavations. Additionally, this system can be upgraded to AccuGrade GCS 900.	Hydraulic Excavators
	For use with endorsed third party boxblade. For finish grading, automatic laser elevation control can be added to reference laser transmitter.	Skid Steer Loaders/ Multi Terrain Loaders
AccuGrade GCS 900	Automatic machine control system with positioning information via the Global Navigation Satellite System (GNSS) or Universal Tracking Sensor (UTS) for complex contours, bulk earthworks and design files.	Motor Graders Track-Type Tractors
	Indicate only machine control system with positioning information via the Global Navigation Satellite System (GNSS) [or for the excavators, Universal Tracking Sensor (UTS)] for complex contours, bulk earthworks and design files.	Hydraulic Excavators Wheel Tractor-Scrapers
Cat Grade and Slope	Integrated system automatically controls cutting rotor depth and cross slope to a preset cutting depth. Contacting or non-contacting sensors plus a cross slope sensor can be used to meet job specifications.	Cold Planers
	Integrated grade and slope system to remove irregularities from paved surfaces and control mat thickness. Features text based display with dual mode which can control both sides of the screed.	Asphalt Pavers
AccuGrade PCS 900	The 3D system is an extension to the 2D AccuGrade Grade and Slope for Asphalt Paver system. It allows paving without a reference surface or string line. Contractors can switch from 2D to 3D depending on job requirements.	Asphalt Pavers
AccuGrade PCS 400	System to remove irregularities from paved surfaces and control mat thickness. Features text based display with dual mode which can control both sides of the screed.	Asphalt Pavers
AccuGrade CCS 900	Measures Cat Compaction Value and when combined with a base station, provides finished grade information. Used to determine when compaction is complete and document results over entire job site.	Soil Compactors
	Used to improve process control. Documents the number of passes a roller made over a section of the site along with the temperature of the asphalt mat during each pass.	Asphalt Compactors

PRODUCT	APPLICATIONS	MACHINES
Computer Aided Earthmoving System (CAES) for Mining	Surface Control, Machine Guidance and Ore Control. Uses high precision GNSS plus on- and off-board software to minimize machine productivity and ore extraction.	Track-Type Tractors, Wheel Dozers, Wheel Tractor-Scrapers, Wheel Loaders, Shovels and Excavators
Computer Aided Earthmoving System (CAES) for Landfill	Uses high precision GNSS plus on- and off-board software to maximize landfill airspace and machine productivity. Ideal for landfill planning, engineering, surveying, grade control, and production monitoring applications in dump areas.	Landfill Compactors, Track-Type Tractors, Wheel Tractor-Scrapers, and Motor Graders
AQUILA™ Drill System	For mining customers that value machine and operator performance reports, precise placement and depth of blast holes, and detailed strata information on each drill hole. Requires radio network and ability to receive GNSS signals.	Blast hole drills
AQUILA Dragline System	Monitor performance and improve machine productivity. Uses a pair of high precision GNSS receivers for accurate bucket positioning.	Draglines
MineStar™ FleetCommander	A modern decision-support tool based on industry standard open systems allowing mines to understand, test, and capture events in their mine. Features an advanced truck assignment system, alarm definition, charting and reporting, field machine communication, machine control, productivity, and machine and materials tracking.	Entire mining fleet (Cat and other brands)
MineStar Health	Provides machine health data and reports.	Mining machines equipped with VIMS™

PRODUCT	APPLICATIONS	MACHINES
VIMS™ System	Provides operators, maintenance, and engineering with vital machine health and production information. VIMS Guardian, a retrofit product, excludes operator display and payload information.	Optional on: 773, 775, 777F Standard on: 784, 785, 789, 793, and 797 Off Highway Trucks; 854 Wheel Dozer; and 992, 993 and 994 Wheel Loaders Retrofit on: 777D and 776D Off Highway Trucks VIMS Guardian is available for D9T, D10T, D10R, D11R and D11T Track-Type Tractors; R1600G, R1700G, R2900G, AD30, AD45B and AD55B Underground Mining Machines; 24H Motor Graders
MINEGEM™ Underground Automation System	This automation system removes the operator from the dangerous situations and allows them to work in a more comfortable, ergonomic environment. Using technology to automate and enhance operations, the system provides safety and productivity benefits for underground mines.	Available as an attachment to all Underground Loaders: R1300G, R1600G, R1700G, R2900G, R2900G XTRA
Cat® Integrated Object Detection System™	Combines cameras, radar, and alarms to notify the operator when something is close to the machine but not within an immediate viewing range. The system is configured with zones around the equipment and objects in those zones trigger various levels of alarms.	785, 789, 793, and 797 Off Highway Trucks
Cat Integrated Remote Control		
Work Area Vision System (WAVS)	One, two, or three camera system providing operator in machine with optimal viewing angles all around equipment.	Entire fleet (Cat and other brands)

## PRODUCT LINK

For more information see [www.cat.com/pl](http://www.cat.com/pl)

Product Link is a fleet management system that allows remote monitoring of equipment with features and capabilities that will improve overall fleet-management effectiveness. Product Link is available for all Cat machines, and included as standard equipment on approximately 75 Cat models delivered to customers in over 50 countries around the world.

Product Link is deeply integrated into the machine interacting with engine, transmission and implement control systems. Events and diagnostic codes as well as hours, fuel, idle time and other detailed information is transmitted and displayed in a secure web based application, known as VisionLink™.

The VisionLink application includes powerful tools and features used to process and convey information to users and dealers. The application also includes essential tools to manage your entire fleet of equipment include mapping, working and idle time, fuel level and more.

Hardware options provide the ability to transmit information from (and to) your equipment via cellular network (GSM) or Low-Earth-Orbit satellites. The family of enabling hardware provides you the ability to select the right fit option for the location for which your fleet operates.

Supporting Hardware

Features	PL522	PL321	PL121
<p><b>Essentials</b> Basic asset management features allow for location monitoring, working vs. idle time and fuel level. Machine, job site or fleet views make it easy to manage all equipment, at all sites, all the time.</p>	<p>Runtime with Idle* Expected Runtime Asset On/Off Notification Location Geo Sites (polygon) Fuel Level* S•O•S™ Notifications*</p>	<p>Runtime with Idle* Expected Runtime Start/Stop Times Location Geo Zones (radius) Fuel Level* S•O•S™ Notifications*</p>	<p>Runtime Location Geo Zones (radius) S•O•S™ Notification*</p>
<p><b>Cat Maintenance</b> Apply an effective and efficient planned maintenance program with this service plan. Know when your machine is due for service and what parts are required with detailed checklists and on-line parts ordering. Manage and document other maintenance events such as inspections, backlogs and planned component services.</p>	<p>PM Service intervals* Service Meter Hours Checklists* Parts lists Partstore Integration*</p>	<p>PM Service intervals* Service Meter Hours Checklists* Parts lists* Partstore Integration*</p>	<p>PM Service Intervals* Service Meter Hours Checklists* Parts lists* Partstore Integration*</p>
<p><b>Cat Health</b> Cat Health features provide insight to the condition of your equipment as well as timely notification of issues as they occur. Temperature and pressure warnings, operator driven events like overspeed or abuse warnings, fluid analysis reports and more.</p>	<p>Continuous Reporting* Event Codes* Diagnostic Codes* Single Sign on to SIS* Links to Troubleshooting*</p>	<p>Scheduled Reporting* Event Codes* Diagnostic Codes* Single Sign on to SIS* Links to Troubleshooting*</p>	
<p><b>Cat Utilization</b> Identify when your equipment is working compared to expected runtime hours. Monitor efficiency with working vs. idle utilization details for both hours and fuel. Easy graphical views allow comparison between equipment, job sites or other groupings of equipment.</p>	<p>Fuel Used While Working* Fuel Used While Idling* Fuel Burn* One hour updates 4 Switch Inputs</p>	<p>Fuel Used While Working* Fuel Used While Idling* Fuel Burn* Daily updates 4 Switch Inputs</p>	
<p><b>Digital Inputs</b> Enables notification from a switch as events occur. For example, connect to a lubrication system to know when the reservoir needs to be refilled or to an evacuation pump so you know when oil is drained.</p>	<p>4 Switch Inputs</p>	<p>4 Switch Inputs</p>	
<p><b>Rapid Reporting</b> Track and trace equipment movement with one minute location updates. Display movement history in multiple map views including street, satellite or terrain.</p>	<p>One minute updates Service Meter Hours Location</p>		

\*Special features are enabled by integration into Cat equipment electronic systems and related applications. Similar features are available for other makes of equipment or Cat machines with mechanical systems.

For more information about Product Link, customers can contact their local Cat dealer or visit [www.cat.com/pl](http://www.cat.com/pl).

## **ACCUGRADE™ GRADE CONTROL SYSTEM (GCS)**

The GCS systems reduce guesswork and costly rework by moving material right the first time, reduces survey costs and increases material utilization. The systems improve operator skills, which reduce labor requirements, aids operators in maintaining a consistent depth, grade and slope across the work site and reduce material cost. GCS Systems compute the location of the machine implement and compare the position to the desired design location and give the operator real-time cut/fill information to achieve grade (indicate-only) or signal the machine hydraulics to move the implement to the desired design automatically (on applicable systems). GCS systems offer these advantages and cost-savings:

- Fuel savings of up to 40%
- Increase productivity by up to 50%
- Reduce guesswork and costly rework by moving material right the first time
- Reduce survey costs up to 90%
- Increase material utilization
- Reduce operator costs
- Reduce labor requirements and costs
- Reduce the need for staking, string lines and grade-checkers
- Extend the work day
- Finish jobs faster

## **AccuGrade GCS 600**

### *Cross slope*

Cross slope systems are the foundation system for motor graders and control one blade tip without any off-board infrastructure. It can be combined with sonic, laser, GNSS or UTS technologies to make fine grading more efficient and productive. Cross slope systems are indicate-only or automatic grade control systems designed to control surface cross slope. Machine mounted sensors are used to calculate necessary blade slope positioning to achieve desired cross slope of the surface. The system makes automatic adjustments to the left or right lift cylinder, typically performed by the operator. The in-cab display delivers all of the cross slope information the operator needs to quickly and easily spread or cut material at the correct cross slope. The operator can select which side of the blade to control automatically and swap direction on the return pass without readjusting the settings. Elevation is controlled manually by matching grade or automatically by adding an elevation control device (sonic or laser).

The cross slope systems are ideal for maintaining accurate cross slope over long distances without the need for infrastructure.

### *Site/laser reference*

Site reference systems are the foundation system for excavators and can be combined with laser, GNSS or UTS technologies to make excavating more efficient and productive. The site reference system is an indicate-only system that provides the operator with precise real-time bucket positioning relative to the desired grade. Using a combination of front linkage (stick, boom and bucket) sensors, the system calculates bucket tip position relative to a grade/survey stake or benchmark. When combined with the site reference system, the optional laser receiver allows the machine to move after obtaining a reference benchmark. The laser receiver attachment references a rotating laser to calculate the desired grade for elevation changes over large work sites, significantly increasing productivity.

The site/laser reference systems are ideal for building pads, trenches, and general utility applications.

### *Laser*

Laser systems are elevation control systems designed for precise grade control with tight tolerances using a laser transmitter and receiver(s). A laser transmitter is set up on the work site and creates a constant grade reference over the work area. A digital laser receiver is mounted on the machine and senses the laser signal as the machine moves across the work site.

When combined with cross slope on a motor grader, the single laser system provides automatic blade adjustments to one side of the blade for automatic control of elevation and cross slope.

When combined with a Level Best boxblade on C Series Skid-Steer Loaders, Multi-Terrain Loaders and Compact Track Loaders, the machine electro-hydraulic controls create an automated grading system capable of extreme accuracy. Unlike conventional laser grading systems for SSL-type machines, the laser system requires no additional externally mounted hydraulic valves or displays, nor any additional in-cab levers, switches, control boxes or cables. The integrated system allows use of the loaders existing controls, keeping the operator securely in the seat and protected by built-in safety features.

The laser systems are ideal for the elevation control on fine grading applications and sites with flat, single or dual slope surfaces, such as industrial, commercial or residential building sites.

### *Sonic*

Sonic systems are elevation control systems designed to control surface elevation. The sonic system uses an ultrasonic sensor to maintain the blade at the same relative vertical distance to an external reference such as a string line or a curb and gutter. The system makes automatic elevation adjustments, typically performed by the operator. The operator simply steers the machine to maintain the sensor over the external reference. When combined with cross slope, the single sonic system provides automatic blade adjustments to one side of the blade for automatic control of elevation and cross slope.

The sonic systems are ideal for the elevation control on fine grading applications on sites using existing curb and gutter or string line references.



### AccuGrade™ GCS 900

GCS 900 systems use 3D design files that are stored on the in-cab display and are ideal for all applications including finishing slopes, excavating and truck loading, complex trenches, site with 3D designs such as super elevations, retention ponds, and golf courses.

#### GNSS

Global Navigation Satellite Systems (GNSS) use satellite technology to deliver precise blade positioning information to the operator in the cab. Using machine-mounted components, an off-board GNSS base station and Real Time Kinematic (RTK) positioning, GNSS provides the information necessary for the system to accurately determine blade positioning with centimeter level accuracy. GNSS systems compute the positioning information on the machine compares the position of the blade relative to the design plane and delivers the information to the operator via an in-cab display. Information such as:

- Blade elevation
- Level of cut/fill necessary to achieve grade
- Visual indication of blade position on design surface
- Graphical view of design plane with machine location

GNSS systems put all the information the operator needs to complete a job in the cab, resulting in a greater level of control. Vertical and horizontal guidance tools visually guide the operator to the desired grade. Automated features allow the hydraulics system to automatically control blade adjustments to move the blade to grade. The operator simply uses the light bars to steer the machine for consistent, accurate grades and slopes resulting in higher productivity with less fatigue.

#### UTS

UTS systems are high-accuracy, dynamic tracking systems that utilize Universal Total Station (UTS) technology on the work site to track a target, which is mounted on the blade of the machine to determine precise 3D positioning. Active target technology allows the system to reliably lock onto and track the intended target. This ensures the correct machine is being tracked and eliminates false lock-ons to other active machine targets, survey crews or reflective surfaces. The UTS instrument continuously measures the targets position and transmits real-time positioning data to the operator via the in-cab display, which shows the exact position of the blade in relation to the design. The system combines the position of the target with the known position of the instrument, machine measurements and sensor outputs to calculate precise positioning of the blade tips. The system uses the positioning data to calculate desired elevation and cross slope. Cut and fill values are computed by comparing the positioning of the blade with the design file. The system makes automatic blade adjustments typically performed by the operator and provides automatic blade control to one or both cutting edge types.

## **ACCUGRADE™ PAVING CONTROL SYSTEM (PCS)**

### **AccuGrade PCS 400**

#### **Cat Grade and Slope**

The two dimensional (2D) Grade and Slope system allows contractors to place precise amounts of asphalt mix on the surface being paved by controlling the screed. The system accepts input from sonic sensors, contacting sensors or grade sensors.

The LSD display can provide control for both sides of the screed. Sealed to withstand both moisture and dust contamination, it alerts the operator with an audible alarm whenever a diagnostic message occurs or when a sensor measures an off-grade condition.

### **AccuGrade PCS 900**

The AccuGrade PCS 900 system utilizes Universal Total Station (UTS) technology and is an extension of the PCS 400 system. It allows paving without a reference surface or string line. Contractors can switch from 2D to 3D depending on requirements. The system accepts input from contacting sensors, sonic sensors, a slope sensor, sonic averaging beam, 3D slope or 3D elevation controls. An SPS Series UTS is required to use the 3D controls.

The AutoAdjust Feature monitors the trailing edge of the screed and automatically corrects for errors to achieve higher accuracy and mat smoothness.

The 3D system will allow contractors to better pave more complex designs such as transitions, highly elevated curves and frequently changing cross slopes.

### **Cat Grade and Slope for Cold Planers**

The two dimensional (2D) Grade and Slope system controls rotor depth and cross slope to a preset cutting depth. The system accepts input from contacting wire rope sensors, non-contacting sonic sensors, a sonic averaging ski or a cross slope sensor.

The display can provide control for both sides of the cutting drum. Sealed to withstand both moisture and dust contamination, it alerts the operator with an audible alarm whenever a diagnostic message occurs or when a sensor measures an off-grade condition.

## ACCUGRADE™ COMPACTION CONTROL SYSTEM (CCS)

### AccuGrade CCS 900

AccuGrade™ Compaction and Temperature Mapping for *asphalt compactors* helps contractors increase efficiency and productivity while recording data for quality control documentation and future planning. The system provides a real-time visual reference of the pass-count and asphalt mat temperature. Utilizing AccuGrade Compaction can lead to better mat quality and higher bonus payments.

Pass-count mapping helps achieve target density and increase roller efficiency. With proper pre-project planning, including machine selection, vibratory selection, and speed control, the operator can execute the rolling pattern in the most efficient manner possible. Incomplete pass coverage can result in lower mat densities, premature road failure, as well as penalties for failure to meet specification requirements.

Temperature mapping helps operators determine when the asphalt is acceptable to compaction.

The display provides real-time pass-count mapping and temperature readings. This enables the operator to visualize where the machine is on the mat and how many passes have been made.

Better process control during construction will result in longer periods without required maintenance on asphalt roads. This reduces material needs and minimizes traffic delays for construction.

### AccuGrade CCS 900

AccuGrade Compaction on a *soil compactor* senses compaction as the machine works and correlates the data with machine position. These capabilities improve work quality while lowering owning and operating costs. Reducing the amount of manpower required enhances sustainability and the number of compaction passes used to finish the job.

The level of compaction is determined based on drum movement measured by an accelerometer (used to predict soil stiffness). The system provides project owners with complete project documentation of the number of passes and stiffness values of the soil.

Elevation mapping is also provided which alerts an operator to inaccuracies in grade elevation.

The display provides the operator with compaction levels compared to target and site coverage information.

## COMPUTER AIDED EARTHMOVING SYSTEM (CAES)

### The Right Material in the Right Place for Maximum Machine Productivity

CAES<sup>ultra</sup> uses high precision GNSS technology to help customers maximize machine productivity and job efficiency. Traditionally, an engineer working in the office creates a site plan on a computer. This information is then transferred to paper, and the surveyor goes out and stakes the area to identify elevation, grade, slope, or material type. Once the machine operator has completed the job, the surveyor resurveys the area and updates the office plan. This process is labor intensive and is prone to a check, rework, recheck approach. CAES revolutionizes this process. Its high precision GNSS system allows the machines to act as surveyors. Changes to a digital terrain model (the engineering design file) are recorded as it occurs. The engineer can work with the updated design and modify it further without stopping the machine. It also provides machine operators and site managers information to eliminate rework, reduce field surveying and more accurately complete the earthmoving plan. CAES combines centimeter-level accuracy with Real Time Kinematic (RTK) initialization times for fast and accurate positioning.

Figure 1. Overview of the System

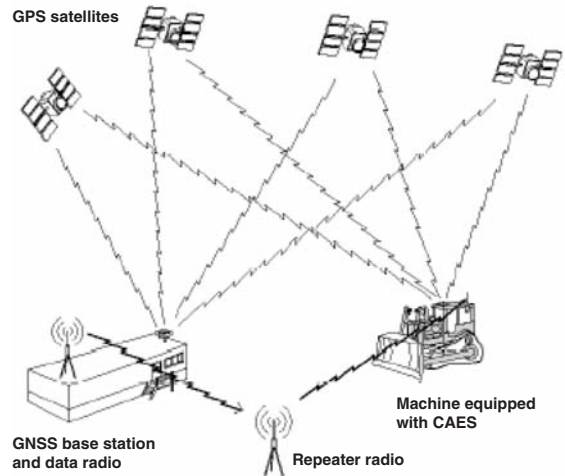

## High Precision Positioning using Global Navigation Satellite System (GNSS)

### Site Requirements

- Line of site to multiple satellites that are part of the GPS or GLONASS constellations. These transmit signals that are used to determine position.
- Base Station with a GNSS receiver and radio. The base station compares its known (or surveyed) position to the position calculated from the GNSS signals. The difference is used to produce a Compact Measuring Record (CMR).
- A radio network to relay the CMRs to machines equipped with CAESultra system.

### On-board Requirements

- Antenna to receive low-precision signals from the GNSS constellation.
- Radio to receive the CMR corrections from the base station.
- Receiver that combines the GNSS signals and CMR corrections to calculate the vehicle position with centimeter accuracy.
- Display running software that provides real-time feedback on job progress and design plan to the operator.

### CAESultra On-board

CAESultra on-board components keep the operator informed with real-time information, which provides greater control and empowerment. Caterpillar has designed the on-board components to meet harsh environmental demands of equipment in mining applications. Easy-to-use software provides the operator with critical information required to get the job done quickly and safely. The on-board system also monitors and logs specific parameters that can be used to determine site productivity as well as individual operator and machine performance.

### CAESultra for Landfill

CAESultra helps the landfill industry conserve airspace. For a landfill compactor, each time the wheel travels over a surface, the CAESultra screen changes color to acknowledge the compaction pass. CAESultra indicates finished areas. The operator achieves maximum effective compaction, by making only the necessary number of passes. Track-type tractors in landfills benefit from CAESultra because it indicates lift thickness of cover material and trash.

Additionally, CAES permits the recording of site-specific storage areas such as hazardous waste, medical, industrial, organic, and other materials which require special handling or a record of placement. All of this information is monitored and managed in the landfill office with CAESultra Office Software.

### CAESultra for Mining

CAESultra moves the material identification file and survey system into the machine, eliminating the need for survey stakes or pin flags. A touch screen monitor displays the location of pit boundaries, material type, bench height, and design grade, eliminating operator guesswork. With material types and locations displayed, ore identification and recovery are optimized.

The CAESultra for Mining system is an ideal tool for mine planning, engineering, surveying, grade control and production monitoring applications. For example, the CAES system can be used for:

- Haul road and bench construction and maintenance
- Production dozing
- Leach pad construction and maintenance
- Reclamation
- Task List Management
- Ore grade control and material identification
- Coal load out terminals

The system can be used on scrapers, loaders, dozers, shovels, motor graders, hydraulic excavators and track-type tractors.

## AQUILA™ DRILL SYSTEM

### Production, Strata Recognition and Guidance

AQUILA Drill Systems are designed for installation on electric and hydraulic rotary blasthole drills. It provides production and performance monitoring, strata recognition and GNSS guidance. Provided as a field retrofit to machines already operating at mine sites, the AQUILA Drill System uses on-board computing integrated with sensors to monitor critical machine performance characteristics. System modules help the operator and site managers enhance drill performance and improve the drilling and blasting operation.

The **Production** module offers a graphical user interface to provide the operator with immediate feedback on drilling productivity and performance. The product minimizes operator input by an array of sensing hardware to detect:

- hole depth
- reaching target depth
- steel changes

The **Strata Recognition** module analyzes the monitored drilling variables in real-time, determining variability in the hole geology. The different strata horizons are presented on the display. The system provides useful and concise information from the start of drilling — not large amounts of raw data that typify traditional drill monitoring systems. A Blastability Index is determined by the Strata Module and approximates the hardness of the ground. The hole-loading requirements and ore grindability predictions are then based on measured rock hardness enabling improved blending and optimized mill throughput rates.

Combining the **Production** module with the **Strata Recognition** module logs:

- bit rotary speed
- penetration rate
- depth
- rotary torque or pressure
- pulldown pressure
- bailing air pressure

Drilling practice, efficiency and productivity can then be analyzed and assessed.

The **GNSS Guidance** module adds high precision GPS to help precisely position a drill on a blast pattern without the need for surveying or staking. The Guidance module uses a moving map display that shows the 3D (Northing, Easting and Elevation) of the drill and drill bit relative to the designed position of the blastholes. Once the drill is positioned and leveled over a hole, the system automatically determines collar elevation and then calculates the designed target depth. Guidance improves the drill's production and utilization, and the operator's ability to drill to the plan. This leads to better rock fragmentation for easier loading. Since holes are drilled to the correct elevation leading to a flatter post-blast surface, the result is smoother pit floors. This helps eliminate rework, enhances the mobile equipment's performance and reduces its wear and tear.

### AQUILA™ Drill Office Software

AQUILA™ Office Software integrates planning and design operations. Engineers can transmit designs to the machine's on-board computer, which show the machine location relative to the design area, current surface, final design surface, and material map (for loading machines). The software package allows you to create customized reports on productivity data, cycle times, volume and material type.

**AQUILA™ DRAGLINE SYSTEM**

The AQUILA Dragline System provides real-time monitoring and reporting of dragline operations. By combining Global Navigation Satellite System (GNSS) and production monitoring data, the system empowers the mining office to plan and control operations. It records the complete, detailed data associated with each load cycle.

The AQUILA Dragline System gives the operator the design plan and real-time position of the dragline relative to the plan in 3D. It also monitors, displays, and logs various parameters from the machine and site.

The dragline system is packaged with Cat Office Software, providing access to the data collected by the on-board components. This enables office personnel to track production and monitor operator performance.

## MINESTAR™ FLEETCOMMANDER

MineStar FleetCommander is the Cat fleet management system developed to maximize mining process productivity while simultaneously maximizing equipment and fleet productivity.

FleetCommander is a modern decision-support tool enabling mines to manage and administer installation, user interface, configuration, security, system administration, database administration, disaster recovery, logging and diagnostics, software updates, calendars, charting and reporting, alarming and scheduled jobs.

The MineStar platform communicates to the mine and integrated process entities with PitLink, the component which manages field communications with machines and fixed plant as well as operators. It also ensures the delivery of the latest on-board software files to all MineStar equipment.

The key office components that are built into the MineStar office to suit the host mine's complexity and needs are:

- **Machine Tracking** provides position analysis of MineStar equipment as it is moved around the travel network.
- **Material Tracking** uses the mine's mining block model for equipment assignment and for loading material according to local blending and production requirements.
- **Operator Management** manages and monitors site personnel for machine licenses, pre-start checklists, scheduled breaks and shift change optimization.
- **Production** monitors site activities, delays, cycles, payload monitoring, Key Performance Indicator (KPI) summaries, fluids and tire management as well as Service Meter Unit (SMU) interpolation.
- **Assignment** applies FleetCommander's assignment engine to provide the best allocation solution when all trucks are considered so that every assignment provided to each truck is always computed considering the most relevant, current information.

FleetCommander provides a proven solution suite based on a single trusted set of data for real-time KPI and for standard and ad-hoc reports. It provides the mine with information to:

- Identify and quantify performance improvement opportunities (within and post shift)
- Develop strategies to capture performance improvement initiatives
- Support engineer and operator performance
- Assign equipment and fleets for maximized fleet production or achievement of material management goals. Capability scales from simple assignment to full truck assignment with linear programming to ensure maximal flexible loader, truck and material capacity utilization
- Blend materials in order to meet preparation plant quality, tonnage and timing requirements
- Track machines and materials to ensure correct delivery of materials from sources to planned sinks and to monitor equipment routing
- Manage operators (licensing, shift allocation and rostering)
- Manage equipment fluids and tires
- Track equipment productivity capability, consumption and variance
- Monitor equipment health including alarms and sensor channel monitoring, pre-start checklists
- Determine "what if" impacts of making specific changes to the product plan

Cost reduction of 10% and greater can be achieved and sustained using MineStar FleetCommander. Cost reductions are typically realized through reduced equipment, manning, lower fuel and service requirements, while achieving the same levels of productivity.



## MINESTAR™ HEALTH

Equipment failures, excessive wear rates, over-temperatures, overloading and degrading operating conditions are all examples of machine health information that when correctly acquired, managed and analyzed can improve a mine's efficiency and lower operating costs.

Caterpillar's MineStar Health system constantly records information on critical machine parameters fleet-wide. Linked with on-board monitoring systems like VIMS, MineStar Health provides wireless or wired transfer of this critical data to the service center for processing and review. It uses VIMS data to remotely monitor events and alarms, allowing focused channel polling to log condition-based event tracking and Application Severity Analysis calculations. It allows service personnel and maintenance planners to track health changes on a large array of on-board components while completing mine duty cycles. Some of the data collected by MineStar Health includes: system voltages, component performance overloading and load/dump/travel/delay times.

MineStar Health is designed to work seamlessly with MineStar FleetCommander or is available as a stand alone health reporting system from your Cat dealer. It can also be integrated into a production database for expanded analysis.

Key benefits of MineStar Health include:

- Saved component failures
- Extended component life
- Reduced phantom breakdowns
- Full fleet health monitoring
- Efficient data analysis
- Improved maintenance practices

## VIMS™ System

VIMS™ is an advanced diagnostic and equipment management tool. By continuously monitoring a wide range of vital machine functions, this high-tech electronic monitoring system improves machine availability, component life, and productivity while reducing both repair costs and risk of catastrophic failure.

By integrating numerous machine sensors into each machine design, VIMS monitors over 250 machine functions and health statistics. Essential machine functions are displayed for the operator via the message center. If a parameter falls outside of the specification, VIMS sends a warning message to the operator and depending on the severity of the event recommends an appropriate course of action. VIMS not only provides important machine and system information to the operator, it also stores a large amount of data about the machine for proactive health and production management.

The third generation of the VIMS System — VIMS 3G — is now available for select Cat Mining equipment, offering enhanced convenience and functionality, along with updated communications capabilities.

### Analysis tools help turn data into decisions.

The software applications of the VIMS Off-Board System include a number of data analysis file types. Each file type analyzes different kinds of information and is used to produce specific results.

- **Event List** records, categorizes and stamps up to 500 system “events” that occur during machine operation.
- **Event Recorder (Snapshot)** helps technicians troubleshoot a specific event by capturing detailed data before and after the event occurs.
- **Data Logger** enables the operator to trigger recording of real-time machine data that can show service personnel exactly what is happening when an event occurs.
- **Payload** helps enhance truck and loading tool effectiveness and improve total fleet production by collecting payload, cycle-time and haul-distance data.
- **Trends, Cumulatives and Histograms** provide a variety of reporting and analysis tools for monitoring specific machine parameters.

### Value of VIMS System

- For the machine operator VIMS establishes two-way communication between the operator and the machine. Real-time machine information allows the operator to make informed decisions that directly affect safety, machine availability, and ultimately the productivity of the mine.
- For maintenance VIMS provides an in-depth view of operator and machine performance. This allows maintenance managers and technicians to maximize component life, reduce catastrophic failures, minimize unscheduled downtime and improve asset management.
- For production VIMS collects the information needed to monitor equipment usage, personnel performance, and productivity levels. Payload information can be used as an accounting tool, an indicator of cycle time efficiency and truck overloading or under loading.

### VIMS Wireless Interfaces

VIMS information can be transmitted wirelessly using VIMS Communicator or Health Interface Module. These units download VIMS data at user programmable intervals and send it back to the office via various telemetry systems.

### VIMS Analysis Tools

VIMS information can be downloaded and viewed by VIMS pc, VIMS 3G Connect and VIMS Supervisor using a laptop at the machine or wirelessly. VIMS information is also available with MineStar Health System.

## CAT® INTEGRATED OBJECT DETECTION SYSTEM™

The Cat® Integrated Object Detection System™ is designed for machines ranging from large mining and quarry trucks to machines such as wheel loaders and motorgraders. It is meant to reduce blind spots and increase perimeter awareness. This robust system includes both radars and a vision system providing optimal awareness around the machine. With both audible and visual indications of a detected object, the Object Detection System helps prevent work area injuries caused by limited awareness. Using a combination of short-range radars, medium-range radars, cameras, and a high-resolution touch screen display, operators can view the areas immediately surrounding their machine, helping to prevent collisions and accidents.

The Object Detection System is highly integrated with the specific machine configuration to optimize radar and camera coverage. The system has been calibrated to provide appropriate fields of view and range. Unlike basic camera systems, the Object Detection System provides operators with audible and visual types of warnings that enable the operator to make informed decisions when moving or operating the machine. When a camera system is running at all times, it's easy for the operator to overlook the screen when performing job tasks. This system alerts the operator when an object is in close proximity so they can decide if action needs to be taken to avoid it.

### Features

- Provides coverage on up to four sides of machine.
- Robust components designed and tested to work in heavy-duty off-road applications.
- Radar detects both moving and non-moving objects.
- System uses visual and audible means to alert operator to objects.
- Cameras allow operator to identify objects detected by radar.
- On-board diagnostics monitor system health and alert operator to any issues.
- Configurations allow operator to adapt system to local conditions.

### Benefits

- Improves site safety by enhancing operator's situational awareness.
- Reduces cost and machine downtime due to accidents.
- Does not require any off-board infrastructure.
- Easy to learn display interface.
- Minimizes nuisance audible alarms.
- Scalable solution allows user to start with camera system and later add radars.

## CAT® INTEGRATED REMOTE CONTROL™

The Cat® Integrated Remote Control™ system enables machine operation from a safe location with the operator removed from the cab. This system enhances operator safety by limiting exposure to full body vibration, dust and sound, and slips, trips and falls from machine ingress/egress. The machine is controlled remotely through use of an Operator Console which is an over the shoulder, line of sight unit. Integrated Remote Control is ideal for use in hazardous situations such as stockpile operations, cleaning up high wall and bench failures, or working with hazardous materials. This system is integrated with engine, implement, and power train controls. Safety controls are built in which stop the machine in case of the loss of radio, transceiver, or ECM communications. The machine will also stop in the event the Operator Console is tipped. Additional protection features include the use of auto-brakes when in neutral and engine over-speed protection. Perhaps the most unique feature is the integration with the Computer Aided Earthmoving System (CAES) avoidance zone functionality which prevents the machine from entering predefined avoidance zones.

Advantages of Integrated Remote Control include:

- Improved system response (more direct control of electro hydraulic system)
- Improved reliability/serviceability (fewer parts/hardened components)
- Enhanced performance features (AutoCarry, ABA)
- Faster installation times (fewer parts)

Engine controls include:

- Engine Start
- Engine Shutdown
- Engine Speed/Throttle
- Engine Deceleration

Implement controls include:

- Blade Control (raise/lower, tilt left/right, pitch forward/back, float)
- Single/Dual Tilt Blade Mode (assuming dual tilt is installed on machine)
- Auto Blade Assist Mode
- AutoCarry
- Ripper Control (raise/lower, in/out, auto stow)
- Implement Lockout

Power train controls include:

- (FNR) Direction
- Gear (1 or 2)
- Steering
- Bi-directional AutoShift
- AutoKickdown
- Service Brake
- Parking Brake

Auxiliary controls include:

- Machine Power
- Lights
- Horn

## MINEGEM™ UNDERGROUND MINING AUTOMATION SYSTEM

Developed out of the need to reduce human exposure to injury, the system removes the operator from dangerous situations and allows them to work in a more comfortable, ergonomic environment. Using technology to automate and enhance operations, the Cat MINEGEM system will increase productivity and make a measurable impact on your mine's bottom line.

MINEGEM offers 2 levels of control:

- Co-pilot: operator-assisted automatic steering
- Auto-pilot: machine is operated under its own self-guidance system

MINEGEM consists of four major sub-systems that support the functionality of the system.

### Operator Station

The Operator Station allows machines to be operated from an ergonomically designed seat in a variety of locations. The operator can safely operate the machine from a mine control room or mobile office, either above or underground. This removes the operator from potentially dangerous environments in the mine drives underground. The Operator Station consists of a computer, three monitors, a seat and two joysticks; one controlling the movement of the machine, the other controlling the bucket.

### Machine Automation System

The Machine Automation System consists of the on-board hardware components that make the MINEGEM system function. LADAR, cameras, lights, sensors, antennas, and control modules combine to create a system that provides safety and productivity for your underground mining operation.

### Area Isolation System

Ensures that personnel cannot enter or equipment cannot leave the Operations Area while the machine is in autonomous mode. The operator has the ability to arm and disarm the system to compensate for changing business needs. A barrier control panel is located at each entry to the Operations Area. These are connected to barriers to ensure the area is secure. The status of each barrier control panel is reported to the programmable logic controller via the Local Area Radio Network (LARN). The programmable logic controller then determines whether the Operations Area should be armed.

### Local Area Radio Network (LARN)

The LARN is a wireless Ethernet data network that enables communication between the machine and the operator station. The network uses the 802.11 b/g protocols and requires exclusive use of the 2.4 GHz RF spectrum.

Signals from the Machine Automation System roam between LARN antennas as the machine moves within the operations area. The signals work primarily over line-of-sight, but can reach a short distance around corners. Video images and data are sent via the LARN.

## WORK AREA VISION SYSTEM (WAVS)

Cat WAVS is offered in one, two or three camera configurations for Cat machines and your entire fleet. WAVS meets Caterpillar's rugged testing to function in tough environments and to withstand harsh climates.

Operators are finding that the use of a reliable camera system allows them to efficiently accomplish the job with minimal risk of machine incidents. Less risk on the job reduces liability and maximizes profit.

### Site Assurance

Position the cameras to view blind spot locations; this reduces machine incidents due to poor visibility. Cameras will reduce the guessing of machine surroundings.

### Work Efficiency

Enhanced visibility around machines increases up-time, operator efficiency and productivity.

### Ergonomics/Comfort

Operator maintains forward direction as display shows machine surrounding and reduces operator's positional motion.

WAVS improves productivity by increasing the operator's field of visibility. The closed circuit camera system can be integrated into the machine so the camera view will be automatically prompted based on camera set-up preference. For example, when the machine is placed in reverse the rear camera is automatically displayed.

## 7" Color LCD Display

- Auto-sensing illumination for changes in light conditions
- 2 Camera views available
  - Panoramic 115°
  - Narrow 78°
- Splash-proof
- Adjustable mounting

## Camera

- Robust design withstands 15G's of vibration and protection from high-pressure washing
- Includes internal heater for removal of condensation, snow, and ice
- Chemically hardened glass, which prevents breakage, scratches and damage



# TABLES

## SWELL — VOIDS — LOAD FACTORS

SWELL (%)	VOIDS (%)	LOAD FACTOR
5	4.8	.952
10	9.1	.909
15	13.0	.870
20	16.7	.833
25	20.0	.800
30	23.1	.769
35	25.9	.741
40	28.6	.714
45	31.0	.690
50	33.3	.667
55	35.5	.645
60	37.5	.625
65	39.4	.606
70	41.2	.588
75	42.9	.571
80	44.4	.556
85	45.9	.541
90	47.4	.526
95	48.7	.513
100	50.0	.500

## BUCKET FILL FACTORS

Loose Material	Fill Factor
Mixed Moist Aggregates	95-100%
Uniform Aggregates up to 3 mm (1/8")	95-100
3 mm-9 mm (1/8"-3/8")	90-95
12 mm-20 mm (1/2"-3/4")	85-90
24 mm (1") and over	85-90
<b>Blasted Rock</b>	
Well Blasted	80-95%
Average Blasted	75-90
Poorly Blasted	60-75
<b>Other</b>	
Rock Dirt Mixtures	100-120%
Moist Loam	100-110
Soil, Boulders, Roots	80-100
Cemented Materials	85-95

**NOTE:** Loader bucket fill factors are affected by bucket penetration, breakout force, rackback angle, bucket profile and ground engaging tools such as bucket teeth or bolt-on replaceable cutting edges.

**NOTE:** For bucket fill factors for hydraulic excavators, see bucket payloads in the hydraulic excavator section.

## TYPICAL ROLLING RESISTANCE FACTORS

Various tire sizes and inflation pressures will greatly reduce or increase the rolling resistance. The values in this table are approximate, particularly for the track and track + tire machines. These values can be used for estimating purposes when specific performance information on particular equipment and given soil conditions is not available. See Mining and Earthmoving Section for more detail.

UNDERFOOTING	ROLLING RESISTANCE, PERCENT*			
	Tires Bias	Tires Radial	Track **	Track +Tires
A very hard, smooth roadway, concrete, cold asphalt or dirt surface, no penetration or flexing . . . . .	1.5%*	1.2%	0%	1.0%
A hard, smooth, stabilized surfaced roadway without penetration under load, watered, maintained . . . . .	2.0%	1.7%	0%	1.2%
A firm, smooth, rolling roadway with dirt or light surfacing, flexing slightly under load or undulating, maintained fairly regularly, watered . . . . .	3.0%	2.5%	0%	1.8%
A dirt roadway, rutted or flexing under load, little maintenance, no water, 25 mm (1") tire penetration or flexing . . . . .	4.0%	4.0%	0%	2.4%
A dirt roadway, rutted or flexing under load, little maintenance, no water, 50 mm (2") tire penetration or flexing . . . . .	5.0%	5.0%	0%	3.0%
Rutted dirt roadway, soft under travel, no maintenance, no stabilization, 100 mm (4") tire penetration or flexing . . . . .	8.0%	8.0%	0%	4.8%
Loose sand or gravel . . . . .	10.0%	10.0%	2%	7.0%
Rutted dirt roadway, soft under travel, no maintenance, no stabilization, 200 mm (8") tire penetration and flexing . . . . .	14.0%	14.0%	5%	10.0%
Very soft, muddy, rutted roadway, 300 mm (12") tire penetration, no flexing . . . . .	20.0%	20.0%	8%	15.0%

\*Percent of combined machine weight.

\*\*Assumes drag load has been subtracted to give Drawbar Pull for good to moderate conditions. Some resistance added for very soft conditions.

## ANGLE OF REPOSE OF VARIOUS MATERIALS

MATERIAL	ANGLE BETWEEN HORIZONTAL AND SLOPE OF HEAPED PILE	
	Ratio	Degrees
Coal, industrial . . . . .	1.4:1—1.3:1	35-38
Common earth, Dry . . . . .	2.8:1—1.0:1	20-45
Moist . . . . .	2.1:1—1.0:1	25-45
Wet . . . . .	2.1:1—1.7:1	25-30
Gravel, Round to angular . . . . .	1.7:1—0.9:1	30-50
Sand & clay . . . . .	2.8:1—1.4:1	20-35
Sand, Dry . . . . .	2.8:1—1.7:1	20-30
Moist . . . . .	1.8:1—1.0:1	30-45
Wet . . . . .	2.8:1—1.0:1	20-45



# Tables

## ROUND REINFORCED CONCRETE PIPE APPROXIMATE WEIGHT PER FOOT

INSIDE DIAMETER		WEIGHT PER FT.	
mm	ft/in	kg	lb
305	12"	42	93
380	15"	58	127
460	18"	76	168
530	1'9"	97	214
610	2'0"	120	265
685	2'3"	146	322
760	2'6"	174	384
840	2'9"	205	452
915	3'0"	238	524
1070	3'6"	311	686
1220	4'0"	393	867
1370	4'6"	485	1069
1525	5'0"	588	1295
1675	5'6"	699	1542
1830	6'0"	821	1811
1980	6'6"	952	2100
2135	7'0"	1093	2409
2285	7'6"	1242	2740
2440	8'0"	1402	3090
2590	8'6"	1578	3480
2740	9'0"	1753	3865

NOTE: Table courtesy of American Concrete Pipe Assn.

## COEFFICIENT OF TRACTION FACTORS

MATERIAL	TRACTION FACTORS	
	Rubber Tires	Tracks
Concrete	.90	.45
Clay loam, dry	.55	.90
Clay loam, wet	.45	.70
Rutted clay loam	.40	.70
Dry sand	.20	.30
Wet sand	.40	.50
Quarry pit	.65	.55
Gravel road (loose not hard)	.36	.50
Packed snow	.20	.27
Ice Semi-skeleton shoes	.12	.12
Firm earth	.55	.90
Loose earth	.45	.60
Coal, stockpiled	.45	.60

NOTE: The elevated sprocket design Track-type Tractors (D11T, D10R, D9R and D8R), with their suspended undercarriage, provide up to 15% more efficient tractive effort than rigid tracked Track-type Tractors.

## SPEED CONVERSION

km/h Equivalents in m/min				MPH Equivalents in FPM			
km/h	m/min	km/h	m/min	mph	fpm	mph	fpm
1	16.7	21	350.0	1	88	21	1848
2	33.3	22	366.7	2	176	22	1936
3	50.0	23	383.3	3	264	23	2024
4	66.7	24	400.0	4	352	24	2112
5	83.3	25	416.7	5	440	25	2200
6	100.0	26	433.3	6	528	26	2288
7	116.7	27	450.0	7	616	27	2376
8	133.3	28	466.7	8	704	28	2464
9	150.0	29	483.3	9	792	29	2552
10	166.7	30	500.0	10	880	30	2640
11	183.3	31	516.7	11	968	31	2728
12	200.0	32	533.3	12	1056	32	2816
13	216.7	33	550.0	13	1144	33	2904
14	233.3	34	566.7	14	1232	34	2992
15	250.0	35	583.3	15	1320	35	3080
16	266.7	36	600.0	16	1408	36	3168
17	283.3	37	616.7	17	1496	37	3256
18	300.0	38	633.3	18	1584	38	3344
19	316.7	39	650.0	19	1672	39	3432
20	333.3	40	666.7	20	1760	40	3520

NOTE: Since 1 km/h equals 16.7 m/min (1000 ÷ 60), to interpolate add 1.67 m/min for each 0.1 km/h.

NOTE: Since 1 mph equals 88 fpm (5280 ÷ 60), to interpolate add 8.8 fpm for every 0.1 mph.

1 mph = 26.9 m/min.

## BEARING POWERS

MATERIAL	BEARING POWER			
	Bar	lb/in <sup>2</sup>	Metric t/m <sup>2</sup>	U.S. tons/ft <sup>2</sup>
Rock (semi-shattered)	4.8	70	50	5
Rock (solid)	24.1	350	240	24
Clay, dry	3.8	55	40	4
medium dry	1.9	27	20	2
soft	1.0	14	10	1
Gravel, cemented	7.6	110	80	8
Sand, compact dry	3.8	55	40	4
clean dry	1.9	27	20	2
Quicksand & alluvial soil	0.5	7	5	0.5

## AGRICULTURAL COMMODITIES CONVERSION FACTORS

	lb	kg	Metric Ton
1 Bushel of Corn*	56	25.40	0.02540
1 Bushel of Soybean*	60	27.22	0.02721
1 Bushel of Oats*	32	14.51	0.01451
1 Bushel of Wheat*	60	27.22	0.02721
1 Bale of Cotton	478	216.81	0.21681

1 metric ton of Corn	39.37 Bushels*
1 metric ton of Soybean	36.75 Bushels*
1 metric ton of Oats	68.92 Bushels*
1 metric ton of Wheat	36.75 Bushels*
1 metric ton of Cotton	4.61 Bales

\*Bushel is a volume measurement, 1 Bushel = 35.24 liters = 9.31 U.S. Gallons. In the agricultural mercantile exchange, the Bushel is widely used for grains as weight. For the above weights, the market assumes a standard density for each type of grain.

### CURVE SUPERELEVATION IN PERCENT GRADE, TO PROVIDE NO LATERAL TIRE FORCE

Negotiating curves can generate high lateral tire forces. These forces contribute to high tire wear and ply separation. Superelevating the curve helps eliminate these forces. The amount of superelevation depends on the curve's radius and the speed at which it is negotiated.

The following table is a guide for providing the superelevation necessary to eliminate lateral forces.

Superelevated turns present a danger when slippery. For this reason, curves superelevated over 10% should be used with caution. Unless the proper speed is maintained, matching the elevation of the curve, a vehicle may slide off of the lower edge of the roadway. Superelevated curves should be maintained in good tractive conditions.

TURN RADIUS		Speed	Speed	Speed	Speed	Speed	Speed	Speed	Speed
m	ft	16 km/h 10 mph	24 km/h 15 mph	32 km/h 20 mph	40 km/h 25 mph	48 km/h 30 mph	56 km/h 35 mph	64 km/h 40 mph	72 km/h 45 mph
15.2	<b>50</b>	13%	30%	—	—	—	—	—	—
30.5	<b>100</b>	7%	15%	27%	—	—	—	—	—
45.7	<b>150</b>	4%	10%	18%	28%	—	—	—	—
61.0	<b>200</b>	3%	8%	13%	21%	30%	—	—	—
91.5	<b>300</b>	2%	5%	9%	14%	20%	27%	—	—
152.4	<b>500</b>	1%	3%	5%	8%	12%	16%	21%	27%
213.4	<b>700</b>	1%	2%	4%	6%	9%	12%	15%	19%
304.9	<b>1000</b>	1%	2%	3%	4%	6%	8%	11%	14%

27

### MAXIMUM SPEED ON CURVES FOR VARIOUS SUPERELEVATION GRADES WITH A 0.20 LATERAL COEFFICIENT OF TRACTION

Another approach to superelevated curves is to determine the safe speed for negotiating a turn at a certain lateral tire force. In general, a 20% lateral coefficient of traction is conservative for all but ice and slippery conditions, making table values safe to use for most applications. The following table shows maximum speed with various superelevations to maintain a 0.20 lateral coefficient of traction.

A transition section may be necessary at higher speeds when entering or departing from a superelevated turn.

TURN RADIUS		Flat Curve		5% Super-elevation		10% Super-elevation	
m	ft	km/h	mph	km/h	mph	km/h	mph
7.6	<b>25</b>	14	<b>9</b>	16	<b>10</b>	17	<b>11</b>
15.2	<b>50</b>	20	<b>12</b>	22	<b>14</b>	24	<b>15</b>
30.5	<b>100</b>	28	<b>17</b>	31	<b>19</b>	34	<b>21</b>
45.7	<b>150</b>	34	<b>21</b>	38	<b>24</b>	42	<b>26</b>
61.0	<b>200</b>	39	<b>24</b>	44	<b>27</b>	48	<b>30</b>
91.5	<b>300</b>	48	<b>30</b>	54	<b>34</b>	59	<b>37</b>
152	<b>500</b>	62	<b>39</b>	70	<b>43</b>	76	<b>47</b>
213	<b>700</b>	74	<b>46</b>	—	—	—	—

# Tables

WEIGHT* OF MATERIALS	LOOSE		BANK		LOAD FACTORS
	kg/m <sup>3</sup>	lb/yd <sup>3</sup>	kg/m <sup>3</sup>	lb/yd <sup>3</sup>	
Basalt	1960	3300	2970	5000	.67
Bauxite, Kaolin	1420	2400	1900	3200	.75
Caliche	1250	2100	2260	3800	.55
Carnotite, uranium ore	1630	2750	2200	3700	.74
Cinders	560	950	860	1450	.66
Clay — Natural bed	1660	2800	2020	3400	.82
Dry	1480	2500	1840	3100	.81
Wet	1660	2800	2080	3500	.80
Clay & gravel — Dry	1420	2400	1660	2800	.85
Wet	1540	2600	1840	3100	.85
Coal — Anthracite, Raw	1190	2000	1600	2700	.74
Washed	1100	1850			.74
Ash, Bituminous Coal	530-650	900-1100	590-890	1000-1500	.93
Bituminous, Raw	950	1600	1280	2150	.74
Washed	830	1400			.74
Decomposed rock —					
75% Rock, 25% Earth	1960	3300	2790	4700	.70
50% Rock, 50% Earth	1720	2900	2280	3850	.75
25% Rock, 75% Earth	1570	2650	1960	3300	.80
Earth — Dry packed	1510	2550	1900	3200	.80
Wet excavated	1600	2700	2020	3400	.79
Loam	1250	2100	1540	2600	.81
Granite — Broken	1660	2800	2730	4600	.61
Gravel — Pitrun	1930	3250	2170	3650	.89
Dry	1510	2550	1690	2850	.89
Dry 6-50 mm (1/4"-2")	1690	2850	1900	3200	.89
Wet 6-50 mm (1/4"-2")	2020	3400	2260	3800	.89
Gypsum — Broken	1810	3050	3170	5350	.57
Crushed	1600	2700	2790	4700	.57
Hematite, iron ore, high grade	1810-2450	4000-5400	2130-2900	4700-6400	.85
Limestone — Broken	1540	2600	2610	4400	.59
Crushed	1540	2600	—	—	—
Magnetite, iron ore	2790	4700	3260	5500	.85
Pyrite, iron ore	2580	4350	3030	5100	.85
Sand — Dry, loose	1420	2400	1600	2700	.89
Damp	1690	2850	1900	3200	.89
Wet	1840	3100	2080	3500	.89
Sand & clay — Loose	1600	2700	2020	3400	.79
Compacted	2400	4050			
Sand & gravel — Dry	1720	2900	1930	3250	.89
Wet	2020	3400	2230	3750	.91
Sandstone	1510	2550	2520	4250	.60
Shale	1250	2100	1660	2800	.75
Slag — Broken	1750	2950	2940	4950	.60
Snow — Dry	130	220			
Wet	520	860			
Stone — Crushed	1600	2700	2670	4500	.60
Taconite	1630-1900	3600-4200	2360-2700	5200-6100	.58
Top Soil	950	1600	1370	2300	.70
Taprock — Broken	1750	2950	2610	4400	.67
Wood Chips**	—	—	—	—	—

\*Varies with moisture content, grain size, degree of compaction, etc. Tests must be made to determine exact material characteristics.

\*\*Weights of commercially important wood species can be found in the last pages of the Logging & Forest Products section. To obtain wood weights use the following equations: lb/yd<sup>3</sup> = (lb/ft<sup>3</sup>) × .4 × 27  
kg/m<sup>3</sup> = (kg/m<sup>3</sup>) × .4

## ALTITUDE DERATION

PERCENT FLYWHEEL HORSEPOWER  
AVAILABLE AT SPECIFIED ALTITUDES

MODEL	0-760 m (0-2500')	760-1500 m (2500-5000')	1500-2300 m (5000-7500')	2300-3000 m (7500-10,000')	3000-3800 m (10,000-12,500')	3800-4600 m (12,500-15,000')
D3K XL	100	100	100	100	88	85
D3K LGP	100	100	100	100	88	85
D4K XL	100	100	100	100	88	85
D4K LGP	100	100	100	100	88	85
D5K XL	100	100	100	100	88	85
D5K LGP	100	100	100	100	88	85
D5N XL & LGP	100	100	100	100	100	100
D6K XL & LGP	100	100	100	100	N/A	N/A
D6N XL & LGP	100	100	100	100	N/A	N/A
D6N XL & LGP**	100	100	100	100	100	100
D6G	100	100	100	100	94	87
D6G Series 2 XL	100	100	100	94	87	80
D6G Series 2 LGP	100	100	100	94	87	80
D6R	100	100	100	100	92	84
D6R Series 3 (All)	100	100	100	100	92	84
D6T (Tier 4 Interim/Stage IIIB)	100	100	100	100	100	88
D7E	100	100	100	98	95	88
D7G	100*	100*	100*	94	86	80
D7G Series 2	100	100	100	100	100	94
D7R Series 2 (All)	100	100	100	100	100	96
D8R	100	100	100	93	85	77
D8T	100	100	100	100	100	93
D9R	100	100	100	93	85	77
D9T	100	100	100	100	100	93
D10T	100	100	100	100	97	89
D11T/D11T CD	100	100	100	93	85	77
120H STD	100	100	100	100	100	100
120M	100	100	100	100	95	88
135H STD	100	100	100	100	100	98
12H STD	100	89	83	77	71	65
12M	100	100	100	100	95	88
140H STD	100	100	100	100	97	89
140M	100	100	100	100	**	**
160H STD	100	100	100	97	89	82
160M	100	100	100	100	**	**
14M	100	100	100	100	100	**
16M	100	100	100	100	100	100
24M	100	100	100	100	**	**

\*Refer to "Captive Vehicle Engine Fuel Specifications" microfiche at your local dealer.

\*\*Information not available at time of printing.

## Tables

### ALTITUDE DERATION (Continued)

MODEL	0-760 m (0-2500')	760-1500 m (2500-5000')	1500-2300 m (5000-7500')	2300-3000 m (7500-10,000')	3000-3800 m (10,000-12,500')	3800-4600 m (12,500-15,000')
216B2	100	89	81	72	61	52
226B2	100	97	95	91	87	83
232B2	100	97	95	91	87	83
236B2	100	97	95	91	87	83
242B2	100	97	95	91	87	83
246C	100	97	95	91	87	83
247B2	100	97	95	91	87	83
256C	100	97	95	91	87	83
257B2	100	97	95	91	87	83
262C	100	97	95	91	87	83
272C	100	97	95	91	87	83
277C	100	97	95	91	87	83
279C	100	97	95	91	87	83
287C	100	97	95	91	87	83
289C	100	97	95	91	87	83
297C	100	97	95	91	87	83
299C	100	97	95	91	87	83
301.5	95	89	81	71	N/A	N/A
301.6	95	89	81	71	N/A	N/A
301.8	95	89	81	71	N/A	N/A
302.5	95	89	81	71	N/A	N/A
303 SR/CR	93	85	78	N/A	N/A	N/A
304 CR	94	87	80	N/A	N/A	N/A
305 SR/CR	96	91	86	N/A	N/A	N/A
307C (4M40)	100	100	*	*	*	*
308C SR/CR	100	100	*	*	*	*
311D LRR	100	100	100	*	*	*
312D/312D L**	100	100	100	*	*	*
312D/312D L***	97	95	92	*	*	*
313C SR/CR	100	100	100	83	78	73
314D CR/314D LCR	100	100	100	*	*	*
315D L**	100	100	100	*	*	*
315D L***	97	95	92	*	*	*
319D L/319 D LN	97	95	92	*	*	*
M313C	100	97	95	91	N/A	N/A
M315C	100	97	95	91	N/A	N/A
M316C	*	*	*	*	*	*
M318C	100	100	97	95	N/A	N/A
M322C	100	100	97	95	N/A	N/A
M313D	*	*	*	*	*	*
M315D	*	*	*	*	*	*
M316D	100	100	100	100	100	98.9
M318D	100	100	100	100	96.6	91.8
M322D	100	100	100	100	96.1	91.9

\*Information not available at time of printing.

\*\*Japan Sourced.

\*\*\*France Sourced.

ALTITUDE DERATION (Continued)

MODEL	0-760 m (0-2500')	760-1500 m (2500-5000')	1500-2300 m (5000-7500')	2300-3000 m (7500-10,000')	3000-3800 m (10,000-12,500')	3800-4600 m (12,500-15,000')
320D/320D RR/323D	100	100	90	87	83	*
320D L/320D LRR/323D L	100	100	90	87	83	*
320C N	100	100	90	87	83	*
320C FM	100	100	90	87	83	*
321D LCR	100	100	90	87	83	*
322C	100	100	100	100	100	97
324D L	100	100	100	100	100	100-96
322C LN	100	100	100	100	100	97
322C FM	100	100	100	100	100	97
325C	100	100	100	100	100	100
325C FM	100	100	100	100	100	100
328D LCR	100	100	100	100	100-96	96-92
329D L	100	100	100	100	100-96	96-92
329D LN	100	100	100	100	100	100
330C	100	100	100	100	100	100
330C FM	100	100	100	100	100	100
336D L	100	100	100	100	100-93	93-86
336D LN	100	100	100	100	100	100
345D	100	100-96	96	96-89	89-82	82-74
345D L	100	100-96	96	96-89	89-82	82-74
365C L	100	100	100	100	95	88
385C/385C L	100	100	100	100	100	97
385C FS	100	100	100	100	100	97
416E/422E (NA)	100†	89	81	71	N/A	N/A
416E/422E (Turbo)	100	100	100	100	N/A	N/A
420E/420E IT	100	100	100	100	N/A	N/A
428E	99	97	95	91	N/A	N/A
430E/430E IT	100	100	100	100	N/A	N/A
432E	99	97	95	91	N/A	N/A
434E	99	97	95	91	N/A	N/A
442E	99	97	95	91	N/A	N/A
444E	99	97	95	91	N/A	N/A
450E	100	100	100	100	N/A	N/A
Forest Products:						
525B	*	*	*	*	*	*
535B	*	*	*	*	*	*
545	*	*	*	*	*	*
517	100	100	100	99	95	87
527	100	100	100	100	99	91
320C FM	*	*	*	*	*	*
322C FM	*	*	*	*	*	*
325C FM	*	*	*	*	*	*
330C FM	*	*	*	*	*	*

\*Information not available at time of printing.

†Up to 600 m (1968 ft).

# Tables

## ALTITUDE DERATION (Continued)

MODEL	0-760 m (0-2500')	760-1500 m (2500-5000')	1500-2300 m (5000-7500')	2300-3000 m (7500-10,000')	3000-3800 m (10,000-12,500')	3800-4600 m (12,500-15,000')
PL61	100	100	100	100	N/A	N/A
572R Series 2	100*	100*	100*	94	86	80
583R	100	100	100	100	94	87
587R/T	100	100	94	87	80	73
621G◀	100	100	100	100	97	90
631G◀	100	100	100	100	97	90
627G Tractor◀	100	100	100	100	97	90
Scraper◀	100*	100*	100*	92	85	79*
637G Tractor◀	100	100	100	100	97	90
Scraper◀	100*	100*	100	95	87	80
657G Tractor◀	100	100	100	94	88	81
Scraper◀	100	100	100	95	90	84
613G	100	100	100	100	95	87
623G◀	100	100	100	100	97	90
770◀	100	100	100	100-96	96-87	87-79
772◀	100	100	100	100-98	98-87	87-77
773F◀	100	100	100	100-97.9	97.9-94.7	94.7-91.7
775F◀	100	100	100	100	100	100-98.6
777D◀	100	100	100-99.5	99.5-94	94-90	90-85
777F◀	100	100	100	100	100-99.5	99.5-91*
785C◀	100	100	100	100	100-93	93-85
785D◀	100	100	100	100	100	100-97
789C◀	100	100	100	100-92.5	92.5-85	85-77.5
789C HAA◀	100	100	100	100	100	100-98.5
793D◀	100	100	100	100-95.5	95.5-88	88-80.5
793D HAA◀	100	100	100	100	100-98.5	98.5-91
793F◀	100	100	100	100	100-93.3	93.3-80
793F HAA◀	100	100	100	100	100	100
797F◀	100	100	100-98.5	98.5-91.2	91.2-85.1	85.1-79.3
797F HAA◀	100	100	100	100	100	100
814F2	**	**	**	**	**	**
824H	**	**	**	**	**	**
834H	**	**	**	**	**	**
844H	100	100	100	98	93	83
854K	100	100	100	98	93	79

\*Refer to "Captive Vehicle Engine Fuel Specifications" microfiche at your local dealer.

\*\*Information not available at time of printing.

†At 4572 m (15,000 ft).

◀EUI engine — Automatic altitude deration.

**NOTE:** Contact factory for deration estimates based upon site specific temperatures and altitudes for altitude range of 3800 to 4600 m (12,500 to 15,000 ft).

ALTITUDE DERATION (Continued)

MODEL	0-760 m (0-2500')	760-1500 m (2500-5000')	1500-2300 m (5000-7500')	2300-3000 m (7500-10,000')	3000-3800 m (10,000-12,500')	3800-4600 m (12,500-15,000')
815F2	***	***	***	***	***	***
825H	***	***	***	***	***	***
816F2	***	***	***	***	***	***
826H	***	***	***	***	***	***
836H	***	***	***	***	***	***
906	95	89	81	71	N/A	N/A
907	95	89	81	71	N/A	N/A
908	99	97	95	91	N/A	N/A
914G/IT14G	99	97	95	91	N/A	N/A
924H/924Hz	100	100	100	100	97	89
928Hz	100	100	100	100	92	85
930H	100	100	100	100	92	85
938H/IT38H	100	100	100	100	N/A	N/A
950H	100	100	100	100	100	N/A
962H/IT62H	100	100	100	100	100	N/A
966H	100	100	100	100	100	100
972H	100	100	100	100	100	100
980H	100	100	100	100	100-93	93-84
988H	100	100	100	95	85	75
990H	100	100	100	98	93	83
992K	100	100	100	98	93	79
993K	100	100	100	99	93	89
994D	100	100	100	100	**	**
994F	100	100	100	100	**	**
939C	100	100	100	100	*	*
953D	100	100	100	100	N/A	N/A
963D	100	100	100	100	N/A	N/A
973C	100	100	100	100	100	98
TH220B	99	97	95	91	N/A	N/A
TH330B	99	97	95	91	N/A	N/A
TH360B	99	97	95	91	N/A	N/A
TH560B	99	97	95	91	N/A	N/A
TH580B	99	97	95	91	N/A	N/A
PM-565B	100	100	100	*	*	*
RM-250C	100	100	100	100	100	100
RM-350B	100	100	100	*	*	*
AP-800C	99	97	95	91	N/A	N/A
AP-900B	*	*	*	*	*	*
AP-1000B	100	100	100-97	97-93	93-89	89-83
AP-650B	100	100	100	97-93	93-89	89-83
AP-655C	100	100	100	100	*	*
AP-1050B	100	100	100-97	97-93	93-89	89-83
AP-1055B	100	100	100-97	97-93	93-89	89-83

\*Information not available at time of printing.

\*\*Automatically derates 3%/300 m (1000 ft) above 3000 m (10,000 ft).

\*\*\*Information not available at time of printing.



## Tables

### ALTITUDE DERATION (Continued)

MODEL	0-760 m (0-2500')	760-1500 m (2500-5000')	1500-2300 m (5000-7500')	2300-3000 m (7500-10,000')	3000-3800 m (10,000-12,500')	3800-4600 m (12,500-15,000')
BG-230	99	97	95	91	N/A	N/A
BG-240C	100	100	100-97	97-93	93-89	89-83
BG-260C	100	100	100-97	97-93	93-89	89-83
BG-225C	99	97	95	91	N/A	N/A
BG-245C	100	100	100-97	97-93	93-89	89-83
BG-2455C	100	100	100-97	97-93	93-89	89-83
BG-650	99	97	95	91	N/A	N/A
CS-323C	95	89	81	71	N/A	N/A
CS-423E	100	100-93	93-85	85-77	77-64	64-53
CS-433E	100	100	100	99-96	96-91	91-85
CS-533E	100	100	100-97	97-93	93-89	89-83
CS-563E	100	100	100	100	100	100
CS-573E	100	100	100	100	100	100
CS-583E	100	100	100	100	100	100
CS-663E	100	100	100	100	*	*
CS-683E	100-99	99-97	97-95	95-93	93-89	89-83
CP-323C	100	100-90	90-83	83-73	73-62	62-52
CP-433E	100	100	100-99	99-96	96-91	91-85
CP-533E	100	100	100-97	97-93	93-89	100
CP-563E	100	100	100	100	100	89-83
CP-573E	100	100	100	100	100	100
CP-583E	100	100	100	100	100	100
CP-663E	100	100	100	100	*	*
CB-214E	95	90	82	72	62	51
CB-224E/CB-225E	95	90	82	72	62	51
CB-334E	95	90	82	72	62	51
CB-335E	95	90	82	72	62	51
CB-434D	95	89	81	71	N/A	N/A
CB-534D/CB-534D XW	100	100	100	100	100	100
CB-634D	100	100	100-97	97-93	93-89	89-83
PS-150C	95	89	81	71	N/A	N/A
PS-360B	99	97	95	91	N/A	N/A
PF-300B	99	97	95	91	N/A	N/A
PS-300B	99	97	95	91	N/A	N/A
R1300G II	*	*	*	*	*	*
R1600G	*	*	*	*	*	*
R1700G	*	*	*	*	*	*
R2900G	*	*	*	*	*	*
R2900G Extra	*	*	*	*	*	*
AD30	*	*	*	*	*	*
AD45B	*	*	*	*	*	*
AD55	*	*	*	*	*	*
AD55B	**	**	**	**	**	**

\*\*Information not available at time of printing.

\*\*For altitude capability, contact your local Global Marketing representative.

**GRADE COMPARISON CHART  
DEGREES — PERCENT — SLOPE**

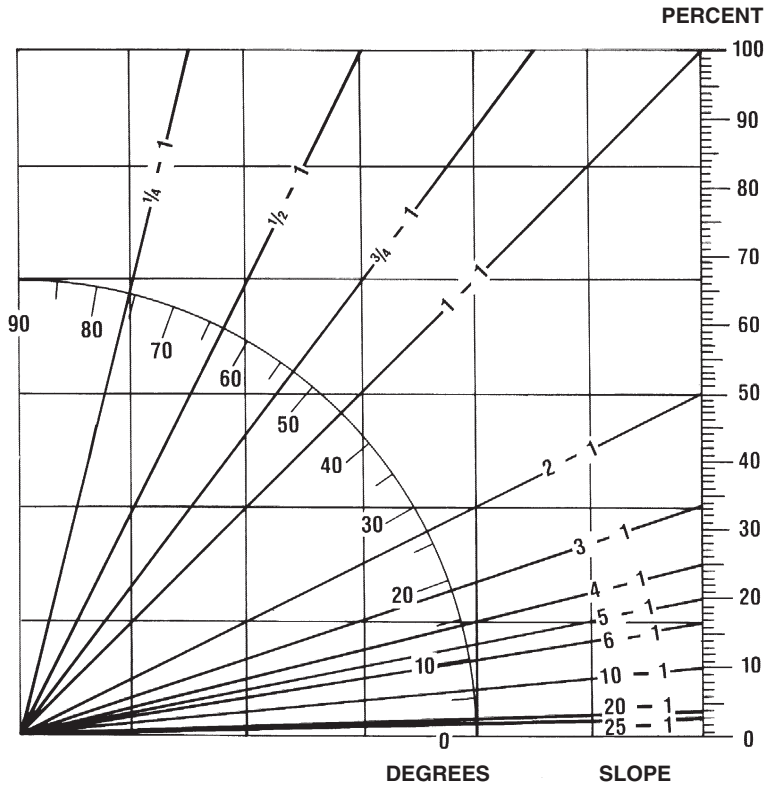

**GRADE IN DEGREES  
AND PERCENTS**

DEGREES	PERCENT
1	1.8
2	3.5
3	5.2
4	7.0
5	8.8
6	10.5
7	12.3
8	14.0
9	15.8
10	17.6
11	19.4
12	21.3
13	23.1
14	24.9
15	26.8
16	28.7
17	30.6
18	32.5
19	34.4
20	36.4
21	38.4
22	40.4
23	42.4
24	44.5
25	46.6
26	48.8
27	51.0
28	53.2
29	55.4
30	57.7
31	60.0
32	62.5
33	64.9
34	67.4
35	70.0
36	72.7
37	75.4
38	78.1
39	81.0
40	83.9
41	86.9
42	90.0
43	93.3
44	96.6
45	100.0

# Tables

## CONVERSION FACTORS

Multiply Metric Unit	By	To Obtain English Unit	Multiply English Unit	By	To Obtain Metric Unit
kilometer (km)	.6214	mile	mile, statute (m)	1.609	kilometer
meter (m)	1.0936	yard	yard (yd)	.9144	meter
meter (m)	3.28	foot	foot (ft)	.3048	meter
centimeter (cm)	.0328	foot	inch (in)	25.4	millimeter
millimeter (mm)	.03937	inch	sq mile (mile <sup>2</sup> )	2.590	sq kilometer
sq kilometer (km <sup>2</sup> )	.3861	square mile	acre	.4047	hectare
hectare (ha)	2.471	acre	sq foot (ft <sup>2</sup> )	.0929	sq meter
sq meter (m <sup>2</sup> )	10.764	square foot	sq inch (in <sup>2</sup> )	.000645	sq meter
sq meter (m <sup>2</sup> )	1550	square inch	cu yard (yd <sup>3</sup> )	.7645	cu meter
sq centimeter (cm <sup>2</sup> )	.1550	square inch	cu inch (in <sup>3</sup> )	16.387	cu centimeter
cu centimeter (cm <sup>3</sup> )	.061	cubic inch	cu foot (ft <sup>3</sup> )	.0283	cu meter
cu meter (m <sup>3</sup> )	1.308	cubic yard	cu inch (in <sup>3</sup> )	.0164	liter
liter (L)	61.02	cubic inch	cubic yard (yd <sup>3</sup> )	764.55	liter
liter (L)	.001308	cubic yard	mph	1.61	km/h
km/h	.621	mph	Ton — mph	1.459	tkm/h
liter (L)	.2642	U.S. gallon	U.S. gallon (US Gal)	3.785	liter
liter (L)	.22	Imperial gallon	U.S. gallon	.833	Imperial gallon
metric ton (t)	.984	long ton	long ton (lg ton)	1.016	metric ton
metric ton (t)	1.102	short ton	short ton (sh ton)	.907	metric ton
kilogram (kg)	2.205	pound, avdp.	pound (lb)	.4536	kilogram
gram (g or gr)	.0353	ounce, avdp.	ounce (oz)	28.35	gram
kilonewton (kN)	225	pound (force)	pound (lb) (force)	.00445	kilonewton
newton (N)	.225	pound (force)	pound (lb) (force)	4.45	newton
cu centimeter (cm <sup>3</sup> )	.0338	fluid ounce	fluid oz (fl oz)	29.57	cu centimeter
kilograms/cu meter	1.686	pounds/cu yd	lb/cu ft (lb/ft <sup>3</sup> )	16.018	kg/cu meter
kilograms/cu meter	.062	pounds/cu ft	lb/cu yd (lb/yd <sup>3</sup> )	.5933	kg/cu meter
kilograms/sq cm (kg/cm <sup>2</sup> )	14.225	pounds/sq in	pounds/sq. in.	.0703	kilogram/sq cm
kilocalorie (kcal)	3.968	Btu	psi	.0689	bar
kilogram-meter (kg•m)	7.233	foot-pound	psi	6.89	kilopascal
meter-kilogram (m•kg)	7.233	pound-foot	Btu	.2520	kilogram-calorie
metric horsepower (CV)	.9863	hp	foot-pound (ft-lb)	.1383	kilogram-meter
kilowatt (kW)	1.341	hp	horsepower (hp)	1.014	metric horsepower
kilopascal (kPa)	.145	psi	horsepower (hp)	.7457	kilowatt
bar	14.5	psi	pounds/cu yd	.0005928	tons/m <sup>3</sup>
tons/m <sup>3</sup>	1692	pounds/cu yd	pounds (No. 2 diesel fuel)	.1413	U.S. gallon
decaliter	.283	bushel	bushel	3.524	decaliter

**NOTE:** Some of the above factors have been rounded for convenience. For exact conversion factors please consult International System of Units (SI) table.

### Temperature conversion

#### Degree C

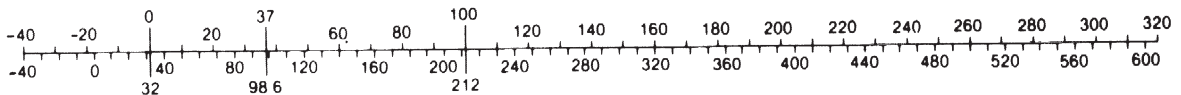

#### Degree F

$$^{\circ}\text{C} = (^{\circ}\text{F} - 32) \div 1.8$$

$$^{\circ}\text{F} = (\text{C} \times 1.8) + 32$$

**METRIC UNIT EQUIVALENTS**

---

1 km	=	1000 m
1 m	=	100 cm
1 cm	=	10 mm
1 km <sup>2</sup>	=	100 ha
1 ha	=	10,000 m <sup>2</sup>
1 m <sup>2</sup>	=	10,000 cm <sup>2</sup>
1 cm <sup>2</sup>	=	100 mm <sup>2</sup>
1 m <sup>3</sup>	=	1000 liters
1 liter	=	1000 cm <sup>3</sup>
1 metric ton	=	1000 kg
1 quintal	=	100 kg
1 N	=	0.10197 kg•m/s <sup>2</sup>
1 kg	=	1000 g
1 g	=	1000 mg
1 bar	=	14.504 psi
1 cal	=	427 kg•m
	=	0.0016 cv•h
	=	0.00116 kw•h
torque unit		
1 CV	=	75 kg•m/s
1 kg/cm <sup>2</sup>	=	0.97 atmosph.

---

**ENGLISH UNIT EQUIVALENTS**

---

1 mile	=	1760 yd
1 yd	=	3 ft
1 ft	=	12 in
1 sq mile	=	640 acres
1 acre	=	43,560 sq ft
1 sq ft	=	144 sq in
1 cu ft	=	7.48 gal liq
1 gal	=	231 cu in
	=	4 quarts liq
1 quart	=	32 fl oz
1 fl oz	=	1.80 cu in
1 sh ton	=	2000 lb
1 lg ton	=	2240 lb
1 lb	=	16 oz, avdp
1 Btu	=	778 ft lb
	=	0.000393 hph
	=	0.000293 kwh
1 mechanical hp	=	550 ft-lb/sec
1 atmosph.	=	14.7 lb/in <sup>2</sup>

---

**POWER UNIT EQUIVALENTS**

---

kW	=	Kilowatt
hp	=	Mechanical Horsepower
CV	=	Cheval Vapeur (Steam Horsepower)
		French Designation For <b>Metric</b> Horsepower
PS	=	Pferdestärke (Horsepower)
		German Designation For <b>Metric</b> Horsepower
1 hp	=	1.014 CV = 1.014 PS
	=	0.7457 kW
1 PS	=	1 CV = 0.986 hp
	=	0.7355 kW
1 kW	=	1.341 hp
	=	1.36 CV
	=	1.36 PS

---

# Tables

Machine Model	Engine Model	Machine Model	Engine Model	Machine Model	Engine Model
<b>Track-Type Tractors</b>		<b>Excavators</b>		<b>Forest Machines</b>	
D3K XL/LGP	C4.4 ACERT	301.6C	Mitsubishi L3E	320D	6.4 ACERT
D4K XL/LGP	C4.4 ACERT	301.8C	Mitsubishi L3E	General Forestry (HW)	
D5K XL/LGP	C4.4 ACERT	302.5C	Mitsubishi S3L2	General Forestry (HD/LC)	
D5N XL/LGP	3126B T	303C CR	Mitsubishi S3Q2	Log Loader (U/U)	
D6K XL/LGP	C6.6 ACERT	303.5C CR	Mitsubishi S3Q2-T	324D	C7 ACERT
D6N XL/LGP	C6.6 ACERT	304C CR	Mitsubishi S4Q2	General Forestry	
D6N XL/LGP*	3126B T	305C CR	Mitsubishi S4Q2-T	General Forestry (O/U)	
D6G	3306 T	307C/307C SB	Mitsubishi 4M40EI	Log Loader (U/U)	
D6G Series 2 XL	3306 T	308C CR	Mitsubishi 4M40EI	325D	C7 ACERT
D6G Series 2 LGP	3306 T	308C SR	K4N	General Forestry	
D6R	C9 ACERT	311D LRR	C4.2 ACERT	General Forestry (O/U)	
D6T	C9 ACERT	312D/312D L	C4.2 ACERT	Log Loader (U/U)	
D7E	C9.3 ACERT	313C SR/CR	3064 T	330D	C9 ACERT
D7G	3306 DITA	314D CR/LCR	C4.2 ACERT	General Forestry	
D7G Series 2	3306 DITA	315D L	C4.2 ACERT	General Forestry (O/U)	
D7R Series 2 (All)	3176C SCAC	319D L/319D LN	C4.2 ACERT	Log Loader (U/U)	
D8R/D8R LGP	3406E TA	M313D	C4.4 ACERT		
D8T/D8T LGP	C15 ACERT	M315D	C4.4 ACERT	<b>Track Harvesters</b>	
D9R	3408E TA	M316D	C6.6 ACERT	501	C6.6 ACERT
D9T	C18 ACERT	M318D	C6.6 ACERT	501HD	C6.6 ACERT
D10T	C27 ACERT	M322D	C6.6 ACERT		
D11T	C32 ACERT	320D/320D L/ 320D RR/320D LRR	C6.4 ACERT	<b>Wheel Harvester</b>	
		321D LCR	C6.4 ACERT	550	C7 ACERT
<b>Motor Graders</b>		323D/323D L	C6.4 ACERT		
120H STD	3116 TA	324D L	Cat C7 ACERT	<b>Wheel Skidders</b>	
120M	C6.6 ACERT	328D LCR	Cat C7 ACERT	525C	C7 ACERT
135H STD	3116 TA	329D L	C7 ACERT	535C	C7 ACERT
12H STD	3306	336D L	C9 ACERT	545C	C7 ACERT
12M	C6.6 ACERT	345B L Series II	3176C ATAAC		
140H STD	3306 T	345D L	C13 ACERT	<b>Track Skidders</b>	
140M	C7 ACERT	365C L	C15 ACERT	517	3304 TA
160H STD	3306 T	385C/385C L	C18 ACERT	527	3304 TA
160M	C9 ACERT	5110B	3412B HEUI		
14M	C11 ACERT	5130B	3508B (EU) TA	<b>Forwarders</b>	
16M	C13 ACERT	5230B	3516B (EU) TA	534	C4.4 ACERT
24M	C18 ACERT			544	C4.4 ACERT
		<b>Front Shovels</b>		564	C6.6 ACERT
		385C FS	C18 ACERT	574	C6.6 ACERT
<b>Skid Steer/Multi-Terrain/ Compact Track Loaders</b>		5130B	3508 (EU) TA	584	C7 ACERT
216B2	C2.2	5230B	3516B (EU) TA	584HD	C7 ACERT
226B2	C2.2T				
232B2	C2.2T	<b>Backhoe Loaders</b>		<b>Pipelayers</b>	
236B2	C3.4 DIT	416E	3054C	PL61	C6.6 ACERT
242B2	C2.2T	420E/420E IT	3054C T	572R Series 2	3176C T
246C	C3.4 DIT	424E	3054C	583R	3406C TA
247B2	C2.2T	428E	3054C T	587R	3406C DITA
256C	C3.4 DIT	430E/430E IT	3054C T	587T	C15 ACERT
257B2	C2.2T	432E	3054C T		
262C	C3.4 DIT	434E	3054C T	<b>Wheel Tractor-Scrapers</b>	
272C	C3.4 DIT	442E	3054C T	613G	C6.6 ACERT
277C	C3.4 DIT	444E	3054C T	623G	C15 ACERT
279C	C3.4 DIT	450E	3054C T	621G	C15 ACERT
287C	C3.4 DIT		C4.4	631G	C18 ACERT
289C	C3.4 DIT			627G Tractor	C15 ACERT
297C	C3.4 DIT			627G Scraper	C9 ACERT
299C	C3.4 DIT			637G Tractor	C18 ACERT
				637G Scraper	C9 ACERT
				657G Tractor	C18 ACERT
				657G Scraper	C15 ACERT

\*Not sold in U.S., Canada or Europe.

Machine Model	Engine Model	Machine Model	Engine Model	Machine Model	Engine Model
<b>Track Feller Bunchers*</b>		<b>Landfill Compactors</b>		<b>Compactors</b>	
511	C9 ACERT	816F	3176 TA	AP1000D	C7 ACERT
521	C9 ACERT	816F II	C9 ACERT	AP655D	C6.6 ACERT
522	C9 ACERT	826G Series II	3406E TA	AP655D (EAME)	C6.6 ACERT
532	C9 ACERT	826H	C15 ACERT	AP755 (EAME)	C7 ACERT
541	C9 ACERT	836G	3456 TA	AP1055D	C7 ACERT
551	C9 ACERT	836H	C18 ACERT	BG-230D	3054C ATAAC
552	C9 ACERT			BG-260D	C7 ACERT
				BG-225C	3054C
<b>Knuckleboom Loaders</b>		<b>Wheel Loaders/Integrated Toolcarriers</b>		<b>Compactors</b>	
519	C6.6 Tier 3	906H	C3.4	<b>Single Drum, Smooth</b>	
529	C6.6 Tier 3	907H	C3.4	CS-323C	3054C
559	C6.6 Tier 3	908H	C3.4	CS-423E	3054C
569	C6.6 Tier 3	914G/IT14G	3054 T	CS-433E	3054C T
579	C6.6 Tier 3	924H/924Hz	C6.6 ATAAC	CS54	C4.4 ACERT
		928Hz	C6.6 ATAAC	CS56	C6.6 ACERT
		930H	C6.6 ATAAC	CS64	C6.6 ACERT
<b>Wheel Feller Buncher</b>		938H/IT38H	C6.6 ATAAC	CS74	C6.6 ACERT
553	C6.6 ACERT	950H	C7 ATAAC	CS76	C6.6 ACERT
563	C7 ACERT	962H/IT62H	C7 ATAAC	CS76 XT	C6.6 ACERT
573	C7 ACERT	966H	C11 ATAAC		
		972H	C13 ATAAC		
		980H	C15 ATAAC	<b>Single Drum, Padded</b>	
<b>Construction &amp; Mining Trucks</b>		988H	C18 ACERT	CP-323C	3054C
770	C15 ACERT	990H	C27 ACERT	CP-433E	3054C T
772	C18 ACERT	992K	C32 ACERT	CP54	C4.4 ACERT
773F	C27 ACERT	993K	C32 ACERT	CP56	C6.6 ACERT
775F	C27 ACERT	994D	3516B TA	CP64	C6.6 ACERT
777D	3508B (EUI) TA	994F	Cat 3516B HD EUI	CP74	C6.6 ACERT
777F	C32 ACERT			CP76	C6.6 ACERT
785C	3512B (EUI) TA	<b>Track Loaders</b>			
785D	3512C HD (EUI) ATAAC	939C	3046 T	<b>Double Drum and Combi</b>	
789C	3516B (EUI) TA	953D	C6.6 ACERT	CB14	C1.1
793D	3516B (EUI) TA	963D	C6.6 ACERT	CB14 XW	C1.1
793F	C175-16 (EUI) ATAAC	973C	C9 ATAAC	CB14 Full Flush	C1.1
797F	C175-20 (EUI) ATAAC			CB22	C1.5
		<b>Telehandlers</b>		CB24	C1.5
<b>Articulated Trucks</b>		TH255	C4.4 DIT	CB32	C1.5
725	C11 ATAAC	TH336	C4.4 DITAAC	CC24	C1.5
730	C11 ATAAC	TH337	C4.4 DITAAC	CB34	C2.2
730 Ejector	C11 ATAAC	TH406	C4.4 DITAAC	CB34 XW	C2.2
735	C15 ATAAC	TH407	C4.4 DITAAC	CC34	C2.2
740	C15 ATAAC	TH414	C4.4 DITAAC	CB-434D	3054C
740 Ejector	C15 ATAAC	TH417	C4.4 DITAAC	CB434D XW	3054C
		TH514	C4.4 DITAAC	CB-534D/CB-534D XW	3054C
<b>Wheel Dozers</b>		TL642	C4.4 EDIT	CB564D	3054C
814F	3176C ATAAC	TL943	C4.4 EDIT		
814F II	C9 ACERT	TL1055	C4.4 EDITAAC	<b>Pneumatic Tire-Asphalt</b>	
824G Series II	3406E ATAAC	TL1255	C4.4 EDITAAC	PS150C	3054C
824H	C15 ACERT			PS360C	3054C ATAAC
834G	3456 TA	<b>Paving Products</b>		PF300C	3054C
834H	C18 ACERT	<b>Cold Planers</b>		PS300C	3054C
844	3412E ATAAC	PM102	C7 ACERT		
844H	C27 ACERT	PM200	C18 ACERT	<b>Underground Mining</b>	
854G	3508B TA	PM201	C18 ACERT	R1300G II	C6.6 ACERT
854K	C32 ACERT			R1600G	3176C EUI ATAAC
		<b>Reclaimer/Soil Stabilizers</b>		R1700G	C11 ACERT ATAAC
<b>Soil Compactors</b>		RM300	C11 ACERT	R2900G	C15 ACERT ATAAC
815F	3176C ATAAC	RM500	C15 ACERT	R2900G Extra	C15 ACERT ATAAC
815F II	C9 ACERT	<b>Asphalt Pavers</b>		AD30	C15 ACERT ATAAC
825G Series II	3406E ATAAC	AP600	C6.6 ACERT	AD45B	C18 ACERT ATAAC
825H	C15ACERT	AP600 (EAME)	3056E ATAAC	AD55	C18 ACERT ATAAC
		AP800D	3054 DIT		

\*Models 511 through 552 are also available as a Track Harvester.

## Tables

Engine Model and (Cylinders)	Machine	Aspiration	Fuel Injection System	Bore × Stroke		Displacement	
				mm	in	L	in³
Mitsubishi L3E (3)	301.6C, 301.8C	NA	DI	76 × 70	3 × 2.8	0.95	58.1
Mitsubishi S3L2 (3)	302.5C	NA	DI	78 × 92	3.1 × 3.6	1.3	80.4
Mitsubishi S3Q2 (3)	303C CR	NA	DI	88 × 103	3.5 × 4.1	1.9	115.9
	303.5C CR	T					
Mitsubishi S4Q2 (4)	304C CR	NA	DI	88 × 103	3.5 × 4.1	2.5	152.9
	305C CR	T					
3013C (3)	CB-214E, CB-224E, CB-225E	NA	DI	75 × 72	2.95 × 3.54	1.50	91.3
3014 (4)		NA	DI	75 × 72	2.95 × 3.54	2.0	122
3024C (4)	CB-334E, CB-335E, 902, 216B, 232B	NA	DI	84 × 100	3.31 × 3.94	2.22	135
	226B, 242B, 247B, 257B	T					
Mitsubishi 4M40EI (4)	307C, 307C SB, 308C CR	NA	DI	95 × 100	3.7 × 3.94	2.84	173
C3.4	906, 907, 908	T	DI	94 × 120	3.7 × 4.72	3.331	203.3
3044C	268B, 267B, 277B, 287B, 236B, 246B, 248B, 252B, 262B	T	DI	94 × 120	3.7 × 4.7	3.3	201
3054C		T		105 × 127	4.13 × 5.0	4.4	268
3054D		T	DI	105 × 127	4.13 × 5.0	4.4	268
3054C (I-4)	416E, 422E	NA	DI	105 × 127	4.13 × 5.0	4.4	268
	(416E), 420E, 420E IT, (422E), 428E, 430E, 430E IT, 432E, 434E, 442E, 444E	T (optional)					
3054E (I-4)	CB-434D, CS-323C, CS-423E, CP-323C, PS-150C	NA	DI	105 × 127	4.13 × 5.0	4.4	268
	AP-800C, BG-230, BG-650, 908, 914G, IT14G, PS-360B, PF-300B, PS-300B, CS-433E, CP-433E, CB-534C	T (optional)					
	M313C, M315C, AP-650B, 315C L**, BG-225C	TA					
3064 (I-4)	311C U, 312C, 314C CR/LCR, 313C SR/CR	T	DI	105 × 127	4.1 × 5.0	4.4	268
3114 (I-4)	446D	T	DI	105 × 127	4.13 × 5.0	4.4	268
3046 (I-6)		NA	DI	94 × 120	3.7 × 4.7	5.0	305
	D3G XL, D3G LGP, D4G XL, CS-533E, D4G LGP, D5G XL, D5G LGP, CP-533E, 315C/315C L*, 939C	T	DI				

\*Japan sourced.

\*\*France sourced.

DI — Direct Injection

T — Turbocharged

TA — Turbocharged and Aftercooled

NA — Naturally Aspirated

**NOTE:** Materials and specifications subject to change without notice. Component commonality of Cat Engines for all applications does not imply complete interchangeability. Contact your Cat dealer for specific information.

Engine Model and (Cylinders)	Machine	Aspiration	Fuel Injection System	Bore × Stroke		Displacement	
				mm	in	L	in <sup>3</sup>
3056 (I-6)	CS-563E, CS-573E, CS-583E, CS-663E, AP-655C, CS-683E, CP-563E, CP-573E, CP-583E, CP-663E, M316C, M318C, M322C	ATAAC	DI	100 × 127	3.94 × 5.0	6.0	365
3066 (I-6)	320C, 320C L, 320C LN, 320C S, 321C LCR	T	DI	102 × 130	4.0 × 5.1	6.4	391
3116 (I-6)	CB-634D, BG-240C, AP-900B	T	DI	105 × 127	4.13 × 5.0	6.6	402
	BG-260C, BG-245C, AP-1050B, AP-1055B, 120H STD, 135H STD, BG-2455C, AP-1000B	TA	DI				
3304 (I-4)	527, 517	TA	DI	121 × 152	4.75 × 6.0	7.0	425
3126 (I-6)	D5**, D6N**, 561N, 953C, 963C	T	DI	110 × 127	4.33 × 5.0	7.2	442
	525B, 535B	TA					
	325C LN	ATAAC					
C4.2 ACERT	311D, 311D LRR, 312D, 312D L, 314D CR, 314D LCR, 315D L, 319D	ATAAC	DI	102 × 130	4.02 × 5.12	4.2	259
C4.4 ACERT	D3K, D4K, D5K, 450E	T	DI	105 × 127	4.13 × 5.0	4.4	269
C6.4 ACERT	320D, 320D L, 320D RR, 320D LRR, 321D LCR, 323D L	ATAAC	DI	102 × 130	4.0 × 5.1	6.4	389
C6.6	R1300G II, 924Hz, 924H, 928Hz, 930H	ATAAC	DI	105 × 127	4.13 × 5.0	6.6	402
C6.6 ACERT	D6K, D6N, 953D, 963D, 120M, 12M, PL61, 613G, 938H, IT38H	TA	DI	105 × 127	4.13 × 5.0	6.6	402
C7 ACERT (I-6)	324D L, 328D LCR, 329D L, 950H, 962H, IT62H	ATAAC	DI	110 × 127	4.33 × 5.0	7.2	442
C9 ACERT (I-6)	336D L, 814F II, 815F II	ATAAC	DI	112 × 149	4.4 × 5.9	8.8	537
C9 ACERT (I-6)	160M, D6T, 336D, 336D L, 336D LN, 627G Sc., 637G Sc., 973C	TA	DI	112 × 149	4.4 × 5.9	8.8	537
3176 (I-6)	572R Series 2, R1600G, 345B L Series II, D7R Series 2 (All), 814F, 815F, 816F	ATAAC	DI	125 × 140	4.92 × 5.5	10.2	629

\*France sourced.

\*\*Not sold in U.S., Canada or Europe.

DI — Direct Injection

T — Turbocharged

TA — Turbocharged and Aftercooled

ATAAC — Air/Air Aftercooled

**NOTE:** Materials and specifications subject to change without notice. Component commonality of Cat Engines for all applications does not imply complete interchangeability. Contact your Cat dealer for specific information.



## Tables

Engine Model and (Cylinders)	Machine	Aspiration	Fuel Injection System	Bore × Stroke		Displacement	
				mm	in	L	in <sup>3</sup>
3306 (I-6)	R1300G, 12H STD, D6G, 140H STD, 160H STD	T	DI	121 × 152	4.75 × 6.0	10.5	638
	D7G	TA	DI				
	545, R1300G	ATAAC	DI				
3196 (I-6)	365B L Series II	ATAAC	DI	130 × 150	5.1 × 5.9	12.0	732
3406 (I-6)	RM-250C, RM-350B, 583R, 587R, D8R, D8R LGP	TA	DI	137 × 165	5.4 × 6.5	14.6	893
	826G Series II, 825G Series II, 824G Series II, AD30	ATAAC	DI				
C11 (I-6)	725, 730, 730 Ejector	ATAAC	DI	130 × 140	5.1 × 5.5	11.2	680
C11 ACERT (I-6)	R1700G, 14M, 966H	TA	DI	130 × 140	5.12 × 5.51	11.1	680
		ATAAC					
C13 ACERT (I-6)	16M, 345D L, 972H	TA	DI	130 × 157	5.12 × 6.18	12.5	763
C15 ACERT (I-6)	D8T, D8T LGP, 587T, 621G, 623G, 627G Tr., 657G Sc., 770	TA	DI	137 × 172	5.4 × 6.75	15.2	928
	R2900G, AD30, 735, 740, 740 Ejector, 824H, 825H, 826H, 980H	ATAAC	DI	137 × 171.5	5.4 × 6.75	15.2	928
3456 (I-6)	834G, 836G, 385B, 385B L, 5090B	ATAAC	DI	140 × 171	5.5 × 6.75	15.8	966
3408 (V-8)	D9R, 589, PM-565B	TA	DI	137 × 152	5.4 × 6.0	18.0	1099
		ATAAC					
C18 (I-6)		TA	DI	145 × 185	5.7 × 7.3	18.1	1104
C18 ACERT	AD45B, AD55, D9T, 631G, 637G Tr., 657G Tr., 988H, 772, 834H, 836H	TA	DI	145 × 185	5.7 × 7.3	18.1	1104
C27 ACERT (V-12)	D10T, 773F, 775F, 990H, 844H	TA	DI	137 × 152	5.4 × 6.0	27.0	1648
3412 (V-12)	D10R, 5110B	TA	DI	137 × 152	5.4 × 6.0	27.0	1649
	844	ATAAC	DI				
3508 (V-8)	D11R, 5130B, 992K, 854G, 777D	TA	DI	170 × 190	6.7 × 7.5	34.5	2105
3512 (V-12)	785C	TA	DI	170 × 190	6.7 × 7.5	51.8	3158
	785D	ATAAC					
3516 (V-16)	789C, 793D, 994D, 5230B, 994F	TA	DI	170 × 190	6.7 × 7.5	69.1	4211
C32 ACERT	777F, 854K, 992K, 993K, D11T, D11T CD	TA	DI	145 × 162	5.7 × 6.4	32.1	1959
C175-16 (V-16)	793F	ATAAC	DI	175 × 220	6.9 × 8.7	84.7	5169
C175-20 (V-20)	797F	ATAAC	DI	175 × 220	6.9 × 8.7	105.8	6456

DI — Direct Injection

T — Turbocharged

TA — Turbocharged and Aftercooled

ATAAC — Air/Air Aftercooled

**NOTE:** Materials and specifications subject to change without notice. Component commonality of Cat Engines for all applications does not imply complete interchangeability. Contact your Cat dealer for specific information.

SEBD0351-41

© 2011 Caterpillar • All Rights Reserved • Printed in USA  
CAT, CATERPILLAR, SAFETY.CAT.COM, their respective logos, "Caterpillar Yellow"  
and the "Power Edge" trade dress, as well as corporate and product identity used  
herein, are trademarks of Caterpillar and may not be used without permission.

**CATERPILLAR**<sup>®</sup>  
TODAY'S WORK. TOMORROW'S WORLD.<sup>™</sup>