

L-1850

GENERATION 2

LeTourneau
MINING
PRODUCTS



ENGINE	2000 hp	1491 kW
PAYLOAD		
STANDARD	120000 lb	54431 kg
HIGH LIFT	110000 lb	49895 kg
BUCKET CAPACITY	sized to material density	
TRUCK MATCH	260 - 360 ton	236 - 327 tonne



POWER MODULE

DIESEL POWER OPTIONS

MTU DETROIT DIESEL ENGINE

Model	Tier One and Tier Two 16V Series 4000 16 cylinders
Type	4-cycle turbocharged
Rated Power	2000 hp (1491 kW) @ 1800 rpm

CUMMINS DIESEL ENGINE

Standard Model	Tier One and Tier Two QSK 60 16 cylinders
Type	4-cycle turbocharged
Rated Power	2000 hp (1491 kW) @ 1800 rpm

The independent power module mounting system, consisting of the engine coupled to the SR generator, is cradled within the rear frame by a three-point isolation system.

RADIATOR/OIL COOLER MODULE

- Replaceable tube type, side-by-side split flow
- Thermostatically controlled, variable speed hydraulic motor-driven, radiator-mounted fan
- Auxiliary oil cooler available for high ambient conditions

EXHAUST SYSTEM

Dual low restriction mufflers with vertical, mid-hood discharge

AIR FILTRATION

PRIMARY

- LeTourneau Self Cleaning KLENZ™ Filtration System
99.9% Efficiency Removing to 0.3 Microns (nominal)
- Extends maintenance intervals
 - Filtered air for engine, drive system cooling and pressurized cab

SECONDARY

Dual safety filters for engine

CONTROL SYSTEM-LINCS II™

LeTOURNEAU INTEGRATED NETWORK CONTROL SYSTEM-LINCS II™

Next generation microprocessor based modular design Vehicle Control Unit with monitoring and diagnostics including integrated data logging and storage.

LINCS II™ uses a dash mounted full color touch screen display as the operator interface. Out of range conditions will cause an audible alarm along with a message screen that is color coded to indicate severity.

In addition, the touch-screen display provides repair technicians with operational data and fault messages.

LINCS II™ LOAD WEIGH

- Displays real-time load per pass, per truck and total loads
- Memory capable of retaining months of production information
 - Capable of interfacing with radio dispatch systems for real-time monitoring

PROPULSION SYSTEM

- LeTourneau Switched Reluctance (SR) Hybrid Technology Propulsion System
- Digital microprocessor controlled traction drive
 - Switched Reluctance (SR) drive advantages include:
 - No commutator, brushes or rotor windings on SR motors or generator
 - Hybrid regenerative energy storage for improved fuel economy
 - Parts commonality - power conversion module identical for motor and generator

TRAVEL SPEED

Forward and reverse 0-12 mph (0-19.31 km/h)

GENERATOR

- LeTourneau G200 SR generator
- Switched Reluctance (SR)

TRACTION MOTORS

- LeTourneau B60 SR motor
- SR all wheel drive (independent SR motor for each wheel)

DRIVE GEARING

- | | |
|-------|---------------|
| Model | LeTourneau 57 |
|-------|---------------|
- In-line gear train mounted within the rim of the tire, transmitting power from the traction motor through the tire/rim assembly.
 - A four-stage planetary drive unit in each position
 - Total reduction 99:1

BRAKING SYSTEM

PRIMARY BRAKE SYSTEM

Electric dynamic braking system is controlled from the accelerator pedal and can bring the loader to a full stop without application of mechanical brakes.

SECONDARY BRAKE SYSTEM

- Air modulated traction motor speed disc brakes
- Single disc and caliper on each traction motor
 - Emergency fail safe brakes are spring applied in the event of air pressure loss

PARKING BRAKE SYSTEM

Spring applied, air release traction motor speed disc brakes

STEERING AND HOISTING SYSTEM

STEERING

Steering function is controlled by a single joystick. LeTourneau's constant engine rpm assures full hydraulic steering response.

- | | | |
|----------------------|------------|---------|
| • Articulation angle | 40° | |
| • Turning Radius | | |
| • Standard Lift | 47 ft 2 in | 14.38 m |
| • High Lift | 49 ft 8 in | 15.14 m |

HOIST AND BUCKET CONTROL

Hoist and bucket control functions are incorporated into a single joystick control. The proportional electro-hydraulic controlled hoist and bucket system is independent of the steering system.

Standard/High Lift Cycle Times:

Hoist	16 Seconds
Dump	4 Seconds
Floot	6 Seconds



HYDRAULIC SYSTEM

HPD DRIVE BOX

- Wet spline design with pressurized, cooled, and filtered lubrication
- Ratio 1:1

PUMPS (Maximum flow rate at 1800 rpm)

Main	Piston (4)	494 gpm	1872 L/min
Steering	Piston	89 gpm	342 L/min
Fan Drive	Piston	45 gpm	171 L/min
Blower	Piston	45 gpm	171 L/min
Accessory	Piston	21 gpm	81 L/min
Cooling System			
Circulating Pump	Vane	108 gpm	409 L/min
Aux. Cooling (optional)	Piston	21 gpm	81 L/min

VALVES

Main	Three (3)	175 gpm	663 L/min
	Pump Pressure	3700 psi	25510 kPa
Steering	One (1)	90 gpm	341 L/min
	Pump Pressure	3400 psi	23443 kPa

CYLINDERS

Double-acting, single-stage (diameter and stroke), (standard and high lift)

• Hoist	15 in x 83 in	381 mm x 2108 mm
• Bucket	12.5 in x 42.8 in	318 mm x 1086 mm
• Steering	7.5 in x 30 in	190 mm x 762 mm

STRUCTURAL

LeTourneau frames are fabricated from high strength, low-alloy steel with excellent weld characteristics and extreme low temperature properties. The front axle is an integral, fixed part of the front frame. The rear axle center oscillates 11 degrees.

Unique LeTourneau forged ball and socket joints are utilized in multiple pivot locations (lift arms, rear axle, frame articulation, hoist cylinders). These joints are superior in absorbing and distributing multi-directional stresses. Features easily replaceable brass liners for long life and easy maintenance.

High strength castings are used in key areas of fabricated structures to reduce stress and improve structural life.

STANDARD FEATURES

TIRES/RIMS

- Tires 58/85-57 L-4
- Rims 47 x 57 with 6" flange

STANDARD EQUIPMENT

- Access Ladder Lights
- Air Clean-Out Hose In Cab
- Air Conditioning / Heater-Defroster (Filtered and Pressurized)
- Air Dryer System
- Air Horn
- Air Tank Bleed System
- Adjustable Automatic Lift Height Cut Off
- Automatic Bucket Leveling Control
- Automatic Electrical Cabinet Lights
- Automatic Lubrication System
- Back-up Alarm, Audible
- Battery Disconnect Switch
- Brake Lights
- Central Air Regulator Box
- Data Analysis and Viewing Software
- Data Logging - Downloadable Production and Maintenance Logs
- Door Interlock on Electrical Cabinet
- Drawbar with tow points
- Emergency Stop Buttons (Cab and Remote Mounted)

- Engine Compartment Lights
- Fire Extinguisher, Manual, 20 lb (9.07 kg)
- FOPS - Falling Object Protection System
- Idle Timer
- Interior Lights
- Isolation Monitor
- Joystick Hoist and Bucket Control
- Joystick Steering Control
- Jump Start
- Ladder Walkway (Rear Access w/Retracting Ladder)
- LED Working Lights (10 Forward, 2 Rear)
- LINCS II™ Alarms
- LINCS II™ Load Weigh & Monitoring
- Mirrors, Rearview (Parabolic)(2)
- Operator Seat (11-Way Adjustable)
- Overspeed Alarm
- Parking Brake
- Retractable Lap Belt with Shoulder Harness
- Rock Deflectors (Bucket)
- ROPS - Rollover Protection Structure
- Selectable Throttle Switch
- Starter Disconnect Switch
- Sun Visor
- Tinted Safety Glass Throughout
- Turn Signals
- Twelve (12) Volt Power Supply In Cab
- Twelve (12) Volt Power Port (2)
- Walk Around Catwalk for Cab
- Windshield Washer Reservoir (2.6 gal)
- Windshield Wiper and Washer (Front & Rear)

OPTIONAL FEATURES

- Auxiliary Hydraulic Oil Cooler
- Auxiliary Steering
- Beacon Light Kit
- Bucket GET Options Available
- Central Service with Fast Fuel
- Cold Weather Package- including:
 - Battery Heater
 - Engine Heating System (Oil and Water)
 - Grease Reservoir Heater
 - Hydraulic Tank Heater
- Fast Fuel
- Fire Detection and Suppression System (Manual)
- Fire Suppression System (Manual)
- Fluid Sampling Kit
- Lift Arms - High Lift
- Tires/Rims
 - Tires - 60/80R-57
 - Rims - 47 x 57 with 5" Flange
- Training Seat (with Lap Belt)
- Video Camera (Rear Mount)

BUCKETS

STANDARD, ISO-RATED CAPACITY:
120000 lb / 54431 kg

HIGH LIFT, ISO-RATED CAPACITY:
110000 lb / 49895 kg

Both rock and coal bucket configurations are available
Buckets sized to material density

BUCKET HARDWARE OPTIONS

- Skid Plates (Replaceable)
- Lip Wear Protection
- Wear Liner Kits

For actual bucket configuration and sizing, consult your dealer representative.

OPERATING CAPACITIES, WEIGHTS AND DIMENSIONS

	STANDARD LIFT		HIGH LIFT	
	40 yd ³	30.58 m ³	37 yd ³	28.29 m ³
Bucket Capacity**	120000 lb	54431 kg	110000 lb	49895 kg
Operating Payload	270000 lb	122470 kg	250000 lb	110223 kg
Static Tipping Loads	Straight	240000 lb	220000 lb	99790 kg
	Full 40° Turn	108862 kg	280672 lb	1248 kN
Breakout Force	276281 lb	1228 kN	280672 lb	1248 kN
Operating Weight	535000 lb	242672 kg	543000 lb	246370 kg

** Standard Rock Bucket based on a material density of 3000 lb/yd³ (1780 kg/m³)

FLUID CAPACITIES

Fuel	1050 gal	3975 L	
Hydraulic	375 gal	1419 L	
SR Converter Cooling System	40 gal	151 L	
Engine Cooling System	110 gal	416 L	
Crankcase (includes filters)	Detroit	54 gal	204 L
	Cummins	66 gal	250 L
	Gearbox	7 gal	27 L
Drivers (each)	25 gal	95 L	

OPERATING DIMENSIONS

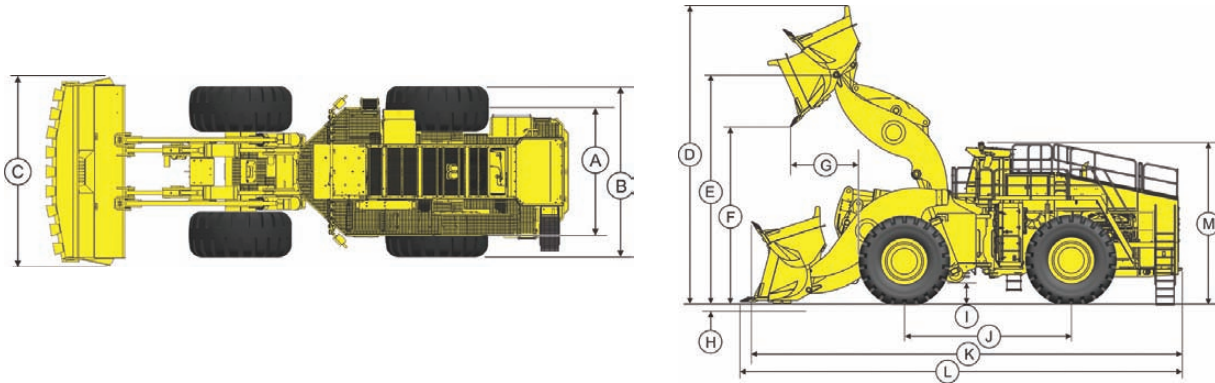

		STANDARD LIFT		HIGH LIFT	
(A)	Tread	15 ft 0 in	4.57 m	15 ft 0 in	4.57 m
(B)	Width Outside Tires	19 ft 10 in	6.04 m	19 ft 10 in	6.04 m
(C1)	Rock Bucket Without Deflectors	21 ft 0 in	6.40 m	21 ft 0 in	6.40 m
(C2)	Rock Bucket With Deflectors	22 ft 0 in	6.71 m	22 ft 0 in	6.71 m
(C3)	Coal Bucket	24 ft 5 in	7.44 m	24 ft 5 in	7.44 m
(D)	Height Bucket Fully Raised	41 ft 3 in	12.57 m	42 ft 5 in	12.93 m
(E)	Hinge – Pin Height	30 ft 10 in	9.40 m	32 ft 6 in	9.91 m
(F)	Dump Clearance	22 ft 5 in	6.83 m	24 ft 3 in	7.39 m
(G)	Reach at Full Lift	10 ft 7 in	3.23 m	10 ft 7 in	3.23 m
(H)	Digging Depth	0 ft 6 in	0.15 m	0 ft 6 in	0.15 m
(I)	Ground Clearance	2 ft 3 in	0.69 m	2 ft 3 in	0.69 m
(J)	Wheelbase	24 ft 6 in	7.47 m	24 ft 6 in	7.47 m
(K)	Overall Length Carry Position	61 ft 4 in	18.69 m	62 ft 6 in	19.06 m
(L)	Overall Length Bucket Down	62 ft 6 in	18.90 m	63 ft 5 in	19.30 m
(M)	Height Over Cab	22 ft 1 in	6.73 m	22 ft 1 in	6.73 m

* All dimensions are based on standard tires and standard rock bucket with GET unless otherwise noted.

LeTourneau

MINING
PRODUCTS

P.O. Box 2307 • Longview, TX 75606 • phone (903) 237-7000 • fax (903) 236-6552 • www.letourneautechnologies.com

Meets the following SAE and ISO Standards:

Braking Systems of Rubber Tired Machines SAE J/ISO 3450 • Loader Buckets Volumetric Ratings ISO 7546 • Sound Measurement Off Road Work Machines - Exterior SAE J 88

Earth Moving Machinery FOPS ISO 3449 • Sound Measurement Off Road Work Machines - Operator SAE J 919 • Rated Operating Load for Loaders SAE J 818

Earth Moving Machinery ROPS ISO 3471 • Earth Moving Machinery Steering Requirements ISO 5010

Please Note: Standard/Optional Equipment, Features and Performance conform to U.S. and International Standards as Required. LeTourneau Technologies, Inc. has made every effort to make these specifications as accurate as possible at the time of printing. However, we reserve the right to make changes and improvements at any time without notice, in equipment, materials and specifications. To ensure the most current information, please contact your dealer representative.

LeTourneau and LINC'S are registered trademarks of LeTourneau Technologies, Inc. ©2011

REV002-072011